



**HAL**  
open science

## Demo: IsamDAE, an Implicit Structural Analysis Tool for Multimode DAE Systems

Benoit Caillaud, Mathias Malandain, Joan Thibault

► **To cite this version:**

Benoit Caillaud, Mathias Malandain, Joan Thibault. Demo: IsamDAE, an Implicit Structural Analysis Tool for Multimode DAE Systems. HSCC 2020 - 23rd ACM International Conference on Hybrid Systems: Computation and Control, Apr 2020, Sydney, Australia. pp.1. hal-02545380

**HAL Id: hal-02545380**

**<https://inria.hal.science/hal-02545380v1>**

Submitted on 17 Apr 2020

**HAL** is a multi-disciplinary open access archive for the deposit and dissemination of scientific research documents, whether they are published or not. The documents may come from teaching and research institutions in France or abroad, or from public or private research centers.

L'archive ouverte pluridisciplinaire **HAL**, est destinée au dépôt et à la diffusion de documents scientifiques de niveau recherche, publiés ou non, émanant des établissements d'enseignement et de recherche français ou étrangers, des laboratoires publics ou privés.

# Demo: IsamDAE, an Implicit Structural Analysis Tool for Multimode DAE Systems

Benoît CAILLAUD, Mathias MALANDAIN, Joan THIBAUT  
 Inria, Univ Rennes, CNRS, IRISA, Hycomes team (Rennes, France)  
 benoit.caillaud@inria.fr – mathias.malandain@inria.fr – joan.thibault@irisa.fr

## DAE FOR THE MODELING OF (LARGE) CYBER-PHYSICAL SYSTEMS

### Large physical systems → *Differential-Algebraic Equations (DAE)*

- Components modeled with a few differential and/or algebraic equations
- Connections: algebraic equations (balance equations, Kirchhoff laws)
- **Pros:** compositional modeling, high reusability of physical components

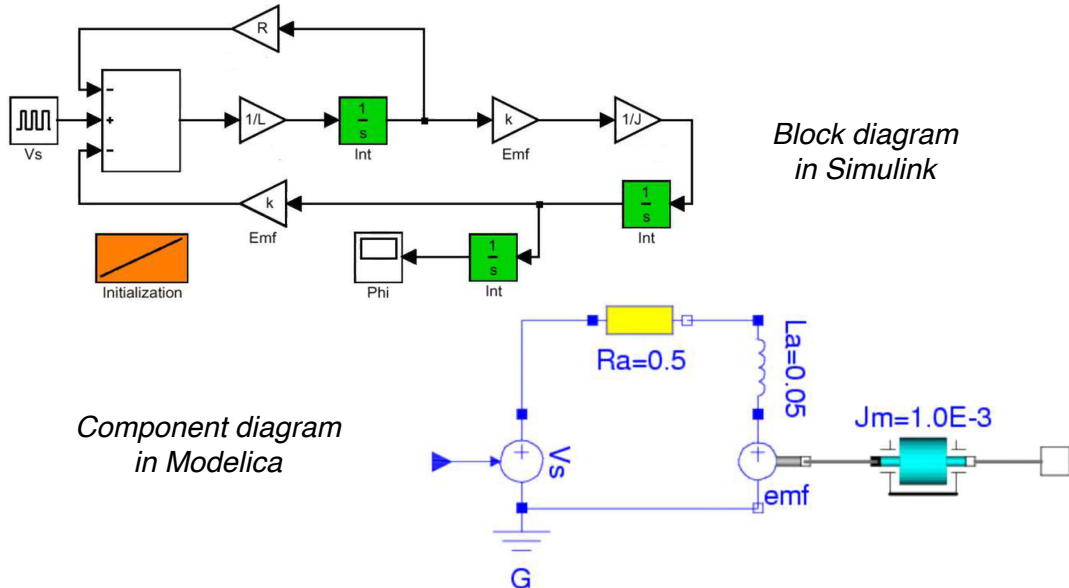

### Non-smooth, or hybrid, systems → *Multimode DAE (mDAE)*

- In general, mDAE are poorly handled by existing tools
  - No proper *structural analysis* of mDAE at compile time

### Variable dimension systems → *Variable dimension models*

- (Dis)appearance of components in a CPS would be easily handled
- Such models are not handled by existing tools

## STRUCTURAL ANALYSIS OF DAE

### Handling DAE systems is harder than ODE

- No direct criterion to determine whether a DAE is determined
- Simulation code cannot be generated from the original model
- Compilation relies on *Structural Analysis (SA)*

### Structural analysis

- Graph-based (Pantelides method) or linear programming (Pryce's Sigma-method) algorithms
- Provides diagnosis about the model at compile time ('typechecking')
- Enables the generation of efficient simulation code:
  - equations are carefully differentiated, and grouped into the smallest possible *equation blocks*;
  - blocks are ordered ('scheduled') for the simulation of a time step

## THE ISAMDAE TOOL

### Structural analysis for mDAE, in an 'all-modes-at-once' fashion

- **Input:** Ad hoc equation language used for declaring mDAE models
  - Implicit representation with BDD (preserves sparsity)
  - Structural analysis (from the Sigma-method) and block scheduling: adaptation of existing methods and novel algorithms
- **Output:** Detailed (but condensed) description of the simulation blocks and their dependencies, in all modes

### Implementation

- About 16,000 lines of OCaml code
- Libraries: menhir, mlbdd, OCaml-Tools, pprint, xml-light
- Software package: GraphViz

## THE RLDC2 EXAMPLE

- Two RLC circuits with ideal diodes, in parallel
- Mode-dependent structure: differentiation orders for the equations, as well as the resulting equation blocks, depend on the mode
- **Not handled by current DAE-based tools** (OpenModelica, Dymola)

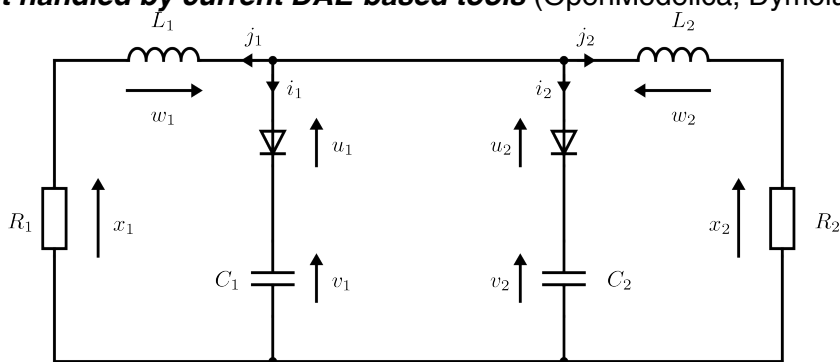

### Mode-dependent structural analysis by IsamDAE

- Checks that the model is determined in all modes
- Generates the mode-dependent scheduling graph shown below
- In each mode: description of the (*ODE-like*) blocks to be compiled into simulation code + dependencies (for their scheduling)
  - ✓ Same results, in each mode, as those of standard structural analysis

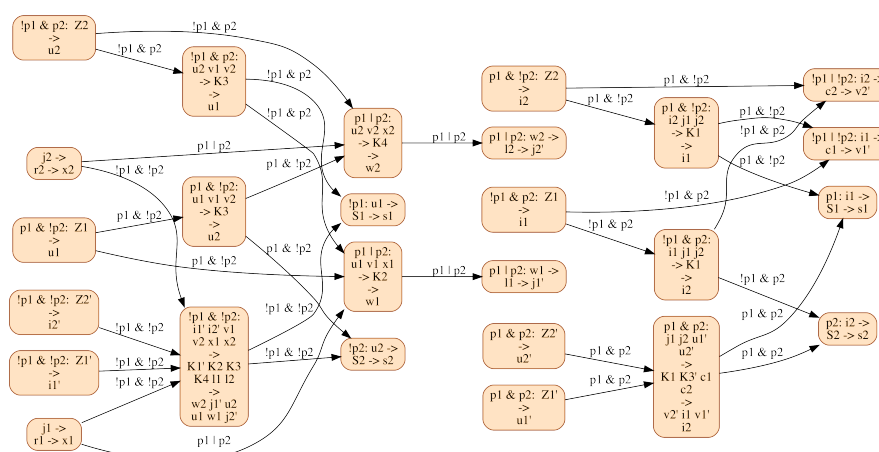

## THE BUILDING EXAMPLE

- **Scalable model:** single-story building with  $N$  rooms and doors
- Instantaneous mode transitions when a door is opened or closed
- Variables taken into account: pressures, temperatures →, air masses, enthalpies, heat and mass flows (compressible air)
- For  $N$  rooms :  $16N+5$  equations and variables,  $6^{N/2}$  modes

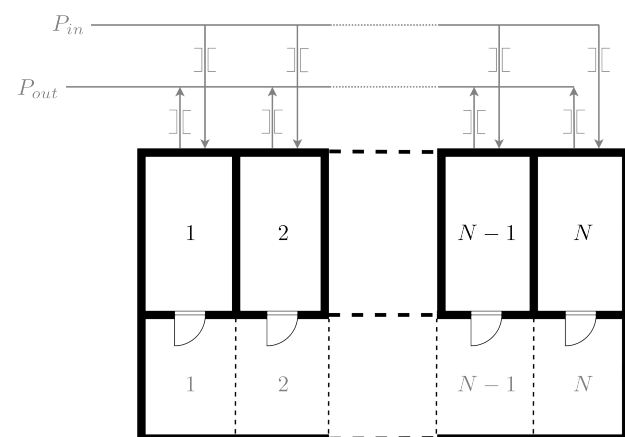

### Scaling-up of the structural analysis by IsamDAE

- The total number of blocks is an affine function of  $N$
- Experimental computation times: about  $O(N^3)$

