



**HAL**  
open science

## F-Interop - Online Conformance, Interoperability and Performance Tests for the IoT

Sebastien Ziegler, Serge Fdida, Thomas Watteyne, César Viho

► **To cite this version:**

Sebastien Ziegler, Serge Fdida, Thomas Watteyne, César Viho. F-Interop - Online Conformance, Interoperability and Performance Tests for the IoT. Conference on Interoperability in IoT (InterIoT), Oct 2016, Paris, France. hal-01363427

**HAL Id: hal-01363427**

**<https://inria.hal.science/hal-01363427>**

Submitted on 20 Dec 2016

**HAL** is a multi-disciplinary open access archive for the deposit and dissemination of scientific research documents, whether they are published or not. The documents may come from teaching and research institutions in France or abroad, or from public or private research centers.

L'archive ouverte pluridisciplinaire **HAL**, est destinée au dépôt et à la diffusion de documents scientifiques de niveau recherche, publiés ou non, émanant des établissements d'enseignement et de recherche français ou étrangers, des laboratoires publics ou privés.

# F-Interop – Online Conformance, Interoperability and Performance Tests for the IoT

Sébastien Ziegler<sup>1</sup>, Serge Fdida<sup>2</sup>, Thomas Watteyne<sup>3</sup>, César Viho<sup>3</sup>

<sup>1</sup> Mandat International, Geneva, Switzerland  
`sziegler@mandint.org`

<sup>2</sup> University Pierre & Marie Curie, Paris, France  
`serge.fdida@lip6.fr`

<sup>3</sup> Inria, France  
`thomas.watteyne@inria.fr, cesar.viho@irisa.fr`

**Abstract.** F-Interop is a platform for online and remote conformance, interoperability and performance tests for the Internet of Things (IoT). This paper outlines the challenges faced by the IoT and its online testing, and how F-Interop addresses them. F-Interop provides an extensive experimental platform for online testing. This paper presents an overview of its overall architecture, and an initial set of results.

**Key words:** Internet of Things, tests, testbed as a service, interoperability, conformance, performance, scalability, privacy.

## 1 Introduction and Project Presentation

The Internet of Things (IoT) is widely considered the next technological revolution impacting all application domains. It is touted to be massive and pervasive, with 50 to 100 billion smart “things” connected by 2020 [1]. It will impact diverse application domains, including smart cities, agriculture, industries and eHealth [2].

Since 1995, interoperability is recognized by the International Telecommunication Union (ITU) as the main obstacle for IoT development and market adoption. The success of this new technological revolution will depend on its ability to overcome its current fragmentation. Overcoming fragmentation requires standardization and interoperability [3].

F-Interop<sup>1</sup> is a European research project addressing this challenge. It develops an platform for online and remote conformance, interoperability and performance testing for the IoT.

This paper gives an overview of the F-Interop platform; it is organized as follows. Section 2 outlines the problem F-Interop addresses. Section 3 presents the technical approach taken. Section 4 shows the architecture of the F-Interop platform. Section 5 discusses the methodology, the current results, and the remaining

---

<sup>1</sup> <http://www.f-interop.eu/>

tasks. Section 6 outlines the expected impact of F-Interop project. Finally, Section 7 concludes this paper.

## 2 Problem Statement

In order to be widely adopted, new technologies, products and solutions typically go through the following steps:

- Standardization: stakeholders discuss and align their views, and converge towards common standards and specifications.
- Conformance & Interoperability: stakeholders test and validate that their implementations conform to the standard(s) it implements, and that they can communicate with one another.
- Optimization: in terms of the Quality of Service, scalability or energy consumption.
- Market Launch: the solution is ready for roll-out.

Developing a product requires extensive testing. This is all the more true for interoperability testing, which verifies that two independent implementations work together. Traditionally, interoperability testing is done through face-to-face “interop events”. Several vendors meet and go through a list of interoperability tests, each one verifying a particular aspect of the implemented standard.

This approach has the following drawbacks:

- It requires engineering teams to travel across the globe, often only to find out they need to make a minor fix. This has a high cost, both in terms of time and money. That cost is often too high for SMEs.
- Time-to-market is stretched, as interop events typically happen every 4-6 months. The result is that vendors who want to adopt emerging standards have a disadvantage compared to vendors who go to market with entirely proprietary solutions.

The goal of F-Interop is to allow compliance and interoperability testing to be both online and remote. “Online” means that the testing is orchestrated by a server somewhere on the web, to which users connect from their offices. “Remote” means that interoperability tests between different vendors can happen through the server, i.e. with requiring the teams to be in same room.

F-Interop targets two audience:

- SMEs and companies. F-Interop allows faster development of standards-based interoperable products, with a time-to-market cut by 6-12 months, and significantly lower overhead.
- Standardization Development Organizations (SDOs). The communities contribute test cases to F-Interop, ensuring better compliance of products to their standards, faster adoption, and eventually a larger portion of standards-based products.

Besides allowing direct interoperability testing between vendors, F-Interop interfaces to the European FIRE research infrastructure<sup>2</sup>, which includes a set of testbeds. This allows F-Interop to run tests at scale against a large number of IoT devices at once.

### 3 Technical Approach

The goal of F-Interop is to extend FIRE+ with online interoperability and performance testing tools supporting emerging IoT-related technologies from research to standardization and to market launch. This benefits researchers, product development by SME, and standardization processes. F-Interop combines the complementary approaches listed below.

*Online Testing Tools.* F-Interop develops online testing tools for the IoT, enabling to test interoperability, conformance, scalability, Quality of Service (QoS), the Quality of Experience (QoE), and energy efficiency of IoT devices and services.

*Testbeds federations with a shared “Testbed as a Service”.* F-Interop brings together 3 testbed federations and facilities, encompassing over 32 testbeds and 4755 IoT nodes:

- **Fed4FIRE**<sup>3</sup>, which federates 24 FIRE+ testbeds, bringing together cloud, IoT, wireless, wireless mobile, LTE, cognitive radio, 5G, openflow, SDN, NFV and network emulation technologies.
- **OneLab**<sup>4</sup>, which federates testbeds for the future Internet, including IoT, cognitive radio, wireless and overlay network technologies.
- **IoT Lab**<sup>5</sup>, which federates IoT and crowdsourcing/crowd-sensing testbeds, including smart campus, smart building and smart office testbeds.

In order to support this integration, F-Interop extends the testbed federation architecture model with a new layer, enabling shared services among several testbed federations. This approach enables to interface “Testbed as a Service” (TBaaS) with existing federations through a clearly specified API, enabling remote access and interaction with various experimental platforms.

*Supporting IoT Standardization and Industry.* F-Interop works in close collaboration with several standardization bodies, and directly contributes to three IoT standardization processes: oneM2M, 6TiSCH (IETF) and the Web of Things (W3C). It also explores the possibility to support and enable new online certification and labeling mechanisms, including the IPv6 Ready logo<sup>6</sup>. More generally,

<sup>2</sup> <http://www.ict-fire.eu/>

<sup>3</sup> <http://www.fed4fire.eu/>

<sup>4</sup> <https://onelab.eu/>

<sup>5</sup> <http://www.iotlab.eu/>

<sup>6</sup> <https://www.ipv6ready.org/>

F-Interop intends to enable an easier participation of researchers and industry in standardization processes. It runs an open call for SMEs and developers, inviting them to use and enrich the platform with additional modules and extensions.

*Flexible Testing Schemes.* F-Interop is researching and exploring various testing schemes and configurations, by interconnecting devices under tests with the server testing tools, resources provided by the F-Interop connected federations of testbeds, and resources provided by other users. This is illustrated in Fig. 1, where a hexagon represents an Implementation Under Test (IUT).

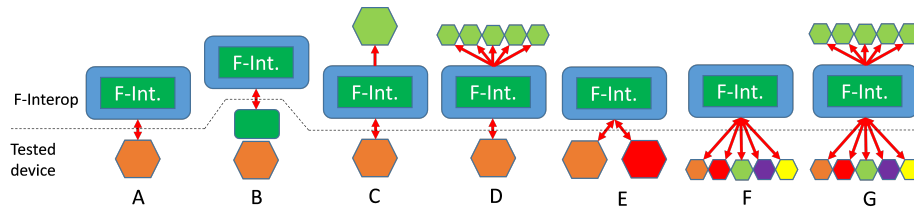

Fig. 1. Multiple testing schemes.

## 4 Initial Architecture

The initial architecture of F-Interop is presented in Fig. 2. A companion paper [4] provides a detailed technical overview of this architecture.

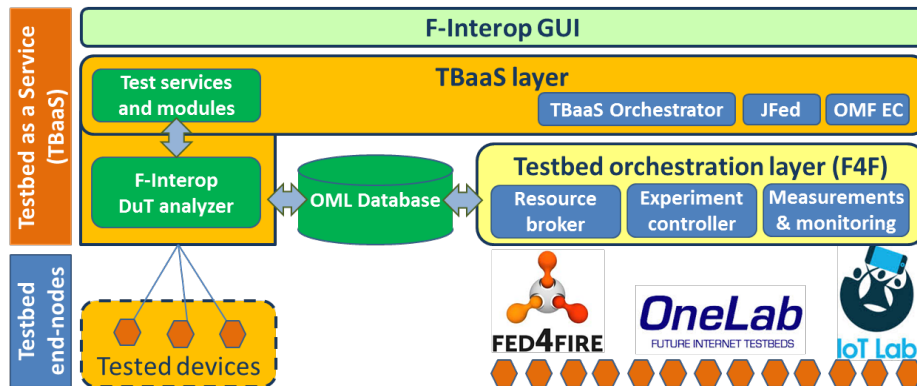
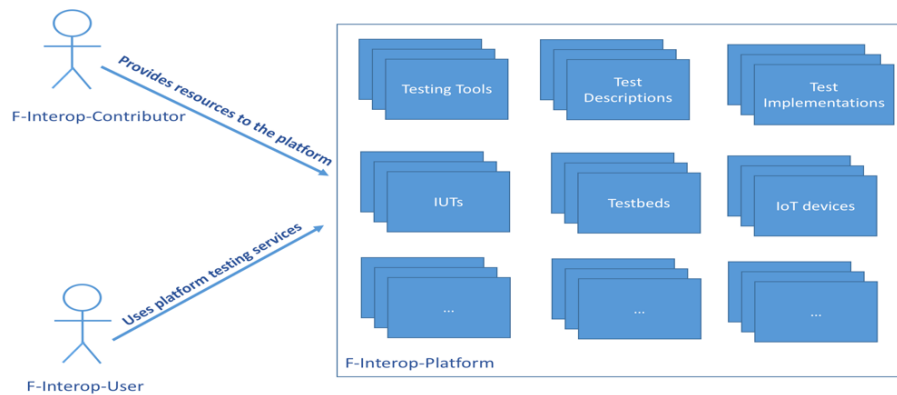

Fig. 2. Initial Architecture.

## 5 Methodology, Current Results and Remaining Tasks

The first step has been to define the F-Interop platform. It is composed of the following three testbeds of FIRE+: IoT-Lab, Fed4FIRE and OneLab. The F-Interop platform will be extended with additive testing tools, devices and testbeds.

The F-Interop platform identifies different types of actors. An F-Interop “Contributor” is an entity that provides testing tools into the platform, as well as testbeds and devices that are added to extend the existing testbeds. An F-Interop “User” is an entity that has an IoT device, system or application to be tested (an IUT) and wants to use the F-Interop platform to test it.



**Fig. 3.** F-Interop main components.

We consider two types of testing tools: online interoperability testing and online performance testing. We target emerging IoT technologies that cover several layers/aspects of the IoT protocol stack, and focus first on IETF 6TiSCH [5] and IETF CoAP [6]. The goal is to use the F-Interop (online) platform for conducting the same tests as conducted during face-to-face interoperability events. Three 6TiSCH plugtests and four CoAP plugtests were organized by ETSI, each with a test description (a list of interoperability tests to execute). The F-Interop platform is built to be able to execute those tests in a remote and online manner. Fig. 4 outlines the resulting overall architecture of the F-Interop platform.

Fig. 5 illustrates how the F-Interop platform can be used for remote online interoperability testing. It distinguishes the control plane – which manages the interactions between components – from the data plane – which executes the tests. A first proof-of-concept has been developed for CoAP online remote interoperability testing [7]. Similar proof-of-concept developments for 6TiSCH and for oneM2M are under development.

Several challenges remain to be addressed:

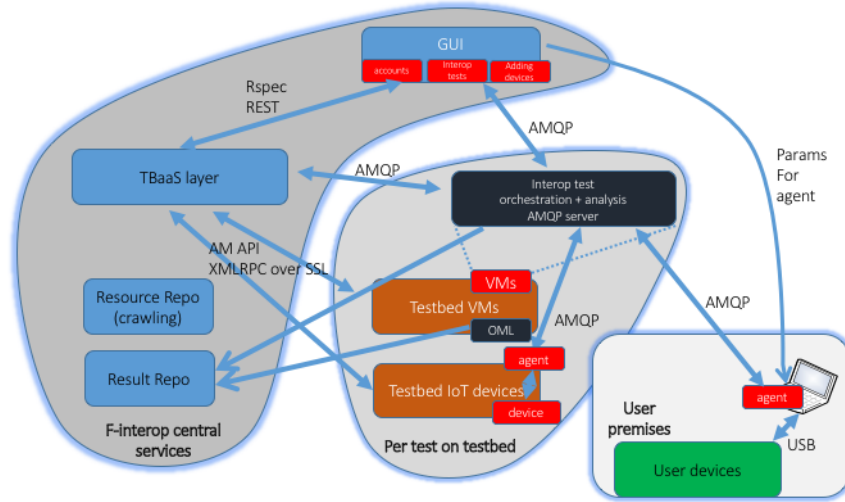

Fig. 4. F-Interop general architecture.

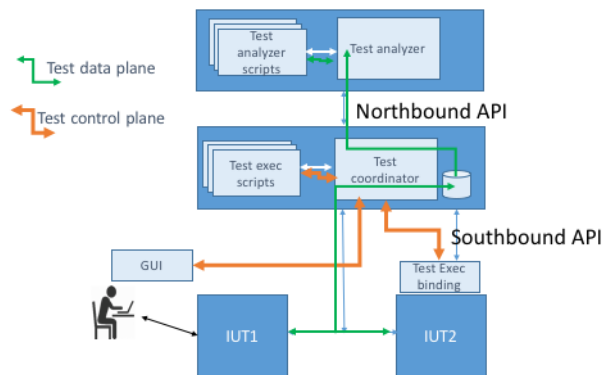

Fig. 5. F-Interop online interoperability testing architecture.

- Define a clear API to integrate the F-Interop testing platform with testbed federations (or federated testbeds) [8].
- Develop the online testing tools: interoperability, conformance, and performance tests.
- Develop a generic and modular platform with an API to extend the interoperability and conformance testing tools to new protocols and standards, in-

cluding by voluntary third parties (contributors) or selected through an open call.

## 6 Expected Impact

F-Interop is an accelerator for new standards and innovations. It provides online interoperability and performance testing tools to support emerging technologies, from research to standardization and market launch. It allows development teams to test their implementations remotely, at any time. It will directly support:

- Standardization communities, enabling them to save time and resources, and be more inclusive with partners who cannot afford traveling, and to accelerate standardization processes.
- SMEs and companies, enabling them to develop standards-based interoperable products with an estimated time-to-market cut by 6-12 months, and significantly lowered engineering and financial overhead.
- Academic communities, by providing a new set of online tools to support their own research and development, as well as by reducing the financial barrier to their participation in standardization processes.

Moreover, F-Interop will provide standardization support to several emerging IoT standards at the IETF (with an initial focus on 6TiSCH), ETSI (with a focus on oneM2M) and W3C (with a focus on Web of Things). The F-Interop architecture is designed to be easily extensible to new standards. More generally, faster availability of standards-based products is expected to result in wider adopt standards and a larger portion of interoperable products.

## 7 Conclusion – towards online interop and performance tests

In order to support IoT research, development and adoption, F-Interop develops a platform for online testing tools encompassing interoperability, compliance and performance tests. It is progressing towards a new model of interoperability test, enabling a larger participation with remote online testing.

The F-Interop platform is still being developed. However, it already announces an open call with funding to develop new partnerships with third parties research projects interested to develop complementary testing tools, address additional standards and/or organize F-Interop based interoperability tests in standardization processes.

## Acknowledgments

The work presented in this article is supported by the F-Interop European research project, under the Horizon 2020 Framework Program supported by the



European Commission. It is implemented by a consortium coordinated by UPMC and Mandat International. F-Interop capitalizes on other projects results, including IoT Lab, Fed4FIRE, and OneLab.

## References

1. Ericson, “More than 50 Billion Connected Devices,” Ericson, Tech. Rep. 284 23-3149, February 2011.
2. S. Ziegler, C. Crettaz, L. Ladid, S. Krco, B. Pokric, A. Skarmeta, A. Jara, W. Kastner, and M. Jung, “IoT6 – Moving to an IPv6-Based Future IoT,” in *Future Internet Assembly (FIA)*. Springer, 2013.
3. S. Ziegler, M. R. Palattella, L. Ladid, S. Krco, and A. Skarmeta, *Internet of Things – From Research and Innovation to Market Deployment*. River Publishers, 2014, ch. Scalable Integration Framework for Heterogeneous Smart Objects, Applications and Services.
4. R. Leone, F. Sismondi, T. Watteyne, and C. Viho, “Technical Overview of F-Interop,” in *International Conference on Interoperability in IoT (InterIoT)*, EAI. Paris, France: Springer, 26-28 October 2016.
5. D. Dujovne, T. Watteyne, X. Vilajosana, and P. Thubert, “6TiSCH: Deterministic IP-enabled Industrial Internet (of Things),” *IEEE Communications Magazine*, vol. 52, no. 12, pp. 36–41, December 2014.
6. Z. Shelby, K. Hartke, and C. Bormann, “The constrained application protocol (coap),” IETF, Tech. Rep. RFC7252, 2014.
7. E. Zack, “F-Interop: Online Interoperability, Performance and Scalability Tests for the Internet of Things [demo],” in *European Conference on Networks and Communications (EUCNC)*, Athens, Greece, 27-30 June 2016.
8. S. Ziegler, M. Hazan, H. Xiaohong, and L. Ladid, “IPv6-based Test beds Integration across Europe and China,” *Testbeds and Research Infrastructure: Development of Networks and Communities*, 2014.