



HAL
open science

Research of PID Algorithm for Valve Controlled Hydraulic Motor Variable Rate Fertilizer Control System

Liang Chunying, Wang Xi, Ji Jianwei, Xu Qianhui, Lü Peng

► **To cite this version:**

Liang Chunying, Wang Xi, Ji Jianwei, Xu Qianhui, Lü Peng. Research of PID Algorithm for Valve Controlled Hydraulic Motor Variable Rate Fertilizer Control System. 7th International Conference on Computer and Computing Technologies in Agriculture (CCTA), Sep 2013, Beijing, China. pp.315-326, 10.1007/978-3-642-54344-9_38 . hal-01220934

HAL Id: hal-01220934

<https://inria.hal.science/hal-01220934>

Submitted on 27 Oct 2015

HAL is a multi-disciplinary open access archive for the deposit and dissemination of scientific research documents, whether they are published or not. The documents may come from teaching and research institutions in France or abroad, or from public or private research centers.

L'archive ouverte pluridisciplinaire **HAL**, est destinée au dépôt et à la diffusion de documents scientifiques de niveau recherche, publiés ou non, émanant des établissements d'enseignement et de recherche français ou étrangers, des laboratoires publics ou privés.



Distributed under a Creative Commons Attribution 4.0 International License

Research of PID Algorithm for Valve Controlled Hydraulic Motor Variable Rate Fertilizer Control System

Liang Chunying^{1,2,a}, Wang Xi^{3,b}, Ji Jianwei^{1,c}, Xu Qianhui^{2,d}, Lü Peng^{2,e}

¹College of Information and Electrical Engineering, Shenyang Agricultural University, Shenyang 110161, China;

²College of Information and Technology, Heilongjiang Bayi Agricultural University, Daqing 163319, China;

³College of Engineering Heilongjiang Bayi Agricultural University, Daqing 163319, China
^andliangchunying@163.com, ^bndwangxi@163.com, ^cjianweiji7879@hotmail.com, ^dxuqh2012@163.com, ^edqlvpeng@163.com

Abstract. In this system, the electromagnetic proportional valve is the actuator, and the valve controlled motor is controlled object, and the speed sensor is the feedback element, to send out the orders by industrial computer, to control the motor output speed by controller. According to the principle of the circuit and fluid mechanics, set up the mathematical model of the valve controlled hydraulic motor variable fertilization system. PID parameters tuning of system were performed by Ziegler-Nichols method, get the coefficient of increment algorithm. The step response of P, PI and PID of variable rate fertilization system were studied by MATLAB/ SIMULINK, results show that: PID algorithm system, the overshoot was small, setting time was short, the number for oscillations was little compared with the P algorithm and PI algorithm, the dynamic performance of the system is excellent. The laboratory experiments results showed that: In the process of system operation, PID algorithm tracking speed was rapid, and steady-state error is smaller. Therefore, the electro-hydraulic proportional variable fertilization system with PID algorithm has good dynamic performance and steady state performance, and can meet the requirements of variable assignment.

Keywords: variable rate fertilizer, mathematical model, PID parameter tuning, valve controlled motor

1 Introduction

Precision agriculture is the development direction of modern agriculture, variable fertilization is the most mature, the most widely used technique in precision agriculture. Variable control system is an important part of the variable machinery, it includes the following the speed regulation control way: electrically controlled mechanical Continuously Variable Transmission, electric control hydraulic motor, electric control step motor. Among them, the electric hydraulic system is widely used which has the characteristics of fast response, output power and high control accuracy, variables to adapt to the demand of large Variable Rate Fertilization. Electro-

hydraulic proportional valve control system for hydraulic motors in response to frequency of fast, short adjusting time, the dynamic characteristics of a good, high efficiency advantages [1-2], in the variable fertilization techniques are more and more widely used [3-7].

In recent years, precision agriculture variable rate fertilizer control strategy mainly around the PID control algorithm [8-12], fuzzy control rules [13-14] and the relevance vector machine [15] and other aspects of the research work commenced in improving the control system performance, increase precision fertilization made a lot of achievements and to promote the domestic development of intelligent variable fertilization seeder. Research process, due to the PID algorithm has the features of a simple structure, robustness and high reliability [16], has been widely used, however, PID parameter tuning is a complex optimization process that determines the performance of the control system, usually Engineering on tuning methods have decay curve method, Ziegler-Nichols step response method, ITSE optimal setting method, rapid titration and relay method and so on. This paper use of the analyzes of mechanism to establish the mathematical model of electro-hydraulic variable rate fertilization system, using Ziegler-Nichols method tuning PID controller parameters, and analysis parameters by testing the impact on system performance.

2 Compositions of Valve Controlled Hydraulic Motor Variable Rate Fertilizer Control System

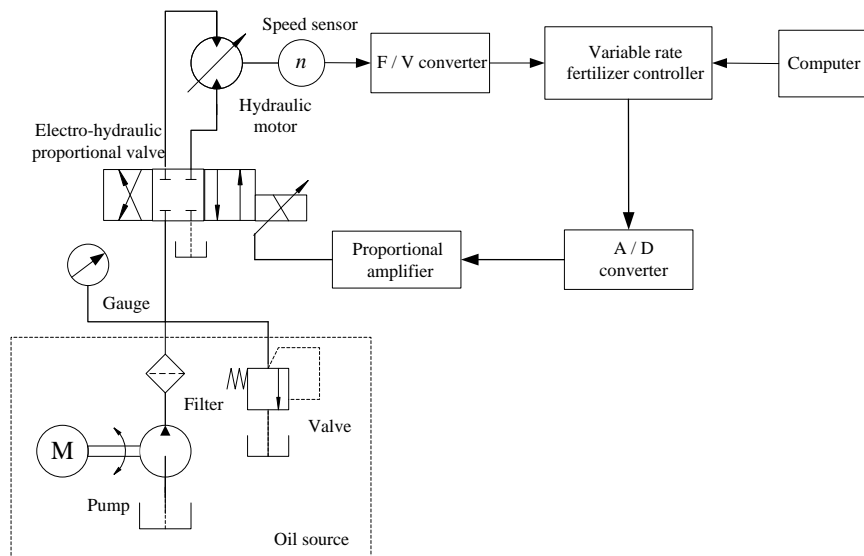

Fig.1. Hydraulic Motor with variable rate fertilization system

Hydraulic Motor with variable rate fertilization system mainly consists of oil sources, electro-hydraulic proportional valves, hydraulic motors, variable rate fertilizer controllers, computers, and speed sensors and so on, as shown in Figure 1. Computer based on fertilizer prescription map given amount of fertilizer, compared with the speed sensor feedback, control algorithm based on the deviation adjusting armature

voltage electro-hydraulic proportional valve, flow size change hydraulic motor speed, driven wheel speed changing of fertilizer to achieve variable rate fertilization.

3 The system mathematical model

The control system of variable rate fertilization through DGPS which is installed in tractor to determine the geographical position, transmitted this information to on-board computer for processing through the RS - 232 serial interface, it will find out the variable fertilization database which corresponding the variable fertilization data and field position, transferred to the variable fertilization controller, Control the opening degree of hydraulic proportional valve, change the axis speed of soybean precision sowing machine, to realize the purpose of variable rate fertilization. The control system of variable rate fertilization system composition was shown in fig.2.

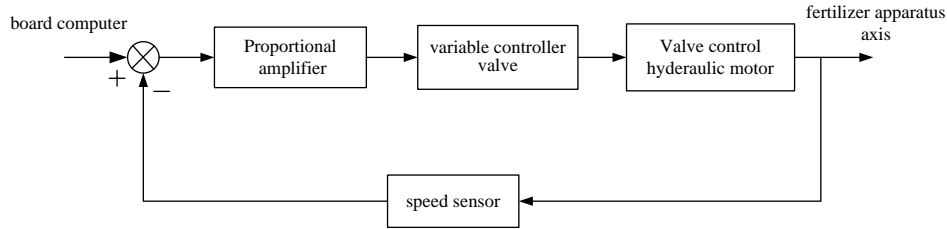

Fig. 2 .valve controlled hydraulic motor system composition

3.1 Transfer Function of Proportion Amplifier

Electro-Hydraulic Proportional Valve is current control type element, usually for the high output impedance voltage - current converter, the band width than hydraulic inherent frequency, can be regarded as amplification link, namely

$$K_a = \frac{I(s)}{U(s)} \quad (1)$$

Where $I(s)$ -Proportion amplifier output current;

$U(s)$ -Error voltage;

K_a -Proportion amplifier gain, $K_a = 0.3A/V$.

3.2 Transfer Function of Proportional Electromagnetic Valve

The system uses the electro-hydraulic proportional pressure pilot control valves, transfer function is second-order oscillation links:

$$G_v(s) = \frac{Q(s)}{I(s)} = \frac{K_q}{\frac{s^2}{\omega_v^2} + \frac{2\zeta_v s}{\omega_v} + 1} \quad (2)$$

Where $K_q = 1.87m^3 / s \cdot A$, $\omega_v = 335.2rad / s$, $\zeta_v = 0.57$

$Q(s)$ -flow of electro-hydraulic proportional valve when in the steady operating points , m³/s;

K_q -flow gain of electro-hydraulic proportional valve in the steady operating points;

ω_v -equivalent undamped natural frequency of electro-hydraulic proportional valve;

ζ_v - equivalent damping coefficient of electro-hydraulic proportional valve;

s - Laplace operator.

3.3 The Mathematical Model of Hydraulic Motor

1) Load Flux Function of Electro-Hydraulic Proportional Valve

$$Q_L = k_q x_v - k_c p_L \quad (3)$$

Where Q_L - load flux of electro-hydraulic proportional valve, m³/s;

x_v -displacement of proportional valves core, m;

p_L -Load pressure, Pa;

k_q -Flow gain,m³/s·A;

k_c -flow pressure coefficient of proportional valves, m⁵/N·s.

2) Flow Rate Continuation Equation of Proportional Valve

The load flux of the output to proportional valve , one part is used to promote a motor motion, another part is used to compensate the various leak of motor, another part is used to compensate flow of compressed. The characteristics of the hydraulic motor for the assumptions:

- (1) all hydraulic pipe is short and coarse, ignore pipe friction losses, ignore the fluid quality effect and pipeline dynamic effect;
- (2) motor oil and volume elastic modulus is constant;
- (3) hydraulic motor for internal and external leakage laminar flow;
- (4) consider liquid compressibility;
- (5) injection system as the constant-voltage source, oil supply pressure as constant.

According to the above assumptions can draw the continuous equation of flow of hydraulic pressure motor

$$Q_L = D_m \frac{d\theta}{dt} + C_m p_L + \frac{V_m}{4\beta_e} \frac{dp_L}{dt} \quad (4)$$

Where Q_L -load flow,m³/rad;

D_m -theoretical displacement of hydraulic motor, m³/rad;

θ -angular displacement of hydraulic motor axis, rad;

C_m -total leakage coefficient of hydraulic motor, m⁵/N· m;

p_L -load pressure drop, N/m²;

V_m -total volume of motor oil cavity, m³;

β_e -integrated elastic modulus of system, N/m³.

3) Moment Equilibrium of Hydraulic Motor

Accord to the quality of motor axis and load, moving damping and spring force, and applied load force, according to Newton's second law can get equilibrium equation of piston force and load force.

$$T_g = D_m(p_1 - p_2) = D_m p_L = J_m \frac{d^2\theta}{dt^2} + B_m \frac{d\theta}{dt} + G\theta + T_L \quad (5)$$

Where T_g -theory torque produced by motor, N·m;

J_m -total inertia of motor axis which is converted hydraulic motor axis and load, kg·m²;

B_m -viscosity damping coefficient of load and motor, N·m·s/rad;

G -torsion stiffness of elastic load, N·m/rad;

T_L -acting on any external grinding load torque of motor axis, N·m.

4) Transfer Function of Hydraulic Motor

$$Q_L(s) = k_q X_v(s) - k_c P_L(s) \quad (6)$$

$$Q_L(s) = D_m s \theta(s) + (C_m + \frac{V_m}{4\beta_e}) P_L(s) \quad (7)$$

$$T_g = D_m P_L(s) = (J_m s^2 + B_m s + G) \theta(s) + T_L(s) \quad (8)$$

To organize and simplified, ignored elastic load, ignored produce term of oil leakage and viscous damping, attainable:

$$\theta(s) = \frac{\frac{k_q}{D_m} x_v(s) - \frac{k_c + C_m}{D_m^2} \left[1 + \frac{V_m}{4\beta_e(k_c + C_m)} s \right] T_L(s)}{s \left(\frac{V_m J_m}{4\beta_e D_m^2} s^2 + \left[\frac{J_m(k_c + C_m)}{D_m^2} + \frac{B_m V_m}{4\beta_e D_m^2} \right] s + 1 \right)} \quad (9)$$

In order to simplify the analysis, some factors can be ignored in the condition of particularly use, especially the simplify or standardize characteristic equations. According to the system is mainly with inertial load, and the motor and load are rigidly connected, so elastic load can be neglected, namely $G = 0$, the pressure - coefficient ratio K_{ce} in all is very small, usually the load's viscous damper coefficient B_m generally are also small, the coupling effect of these two are smaller, namely $\frac{B_m K_{ce}}{D_m^2} \ll 1$, "(9)" can be simplified as:

$$\theta(s) = \frac{\frac{k_q}{D_m} x_v(s) - \frac{k_{ce}}{D_m^2} \left[1 + \frac{V_m}{4\beta_e k_{ce}} s \right] T_L(s)}{s \left(\frac{s^2}{\omega_h^2} + \frac{2\zeta_h}{\omega_h} s + 1 \right)} \quad (10)$$

Where $\omega_h = \sqrt{\frac{4\beta_e D_m^2}{V_t J_t}} = 183.6 \text{ rad/s}$, $\zeta_h = \frac{K_{ce}}{D_m} \sqrt{\frac{\beta_e J_t}{V_t}} = 0.12$

ω_h - undamped oscillation angular frequency;

ζ_h -Hydraulic damping ratio;

Flux near by point of stable state, according to“(10)” can get the transfer function of flux and external grinding load which is motor output angular displacement are:

$$\frac{\theta(s)}{Q(s)} = \frac{1}{D_m} \frac{1}{s(\frac{s^2}{\omega_h^2} + \frac{2\zeta_h}{\omega_h}s + 1)} \quad (11)$$

$$\frac{\theta(s)}{F_L(s)} = \frac{\frac{k_{ce}}{D_m^2}(1 + \frac{V_f}{4\beta_e K_{ce}}s)}{s(\frac{s^2}{\omega_h^2} + \frac{2\zeta_h}{\omega_h}s + 1)} \quad (12)$$

The mathematical modeling of proportional valve was shown in fig. 3 below.

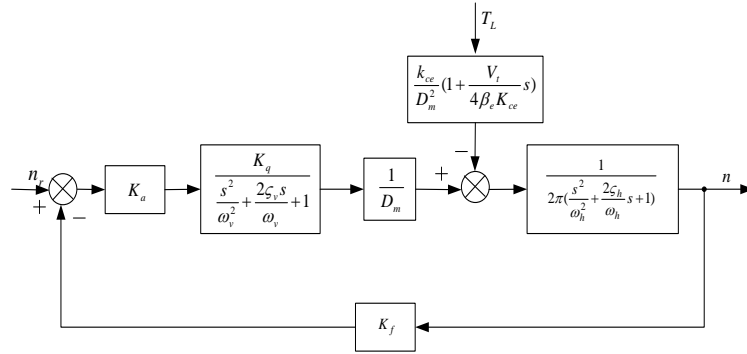

Fig.3. the mathematical modeling of electro-hydraulic proportional valve control system

4 PID parameters setting

PID algorithm is one of the earliest control strategy, system error will be linear combination of the proportion, integral and differential of control signal, constitute the controlled object. The method is widely used in industrial process control Because of simple and good robustness and high reliability etc., PID strategy controller for:

$$u(t) = K_p [e(t) + \frac{1}{T_I} \int_0^t e(t) dt + T_D \frac{de(t)}{dt}] \quad (13)$$

Where $e(t)$ - Control deviation;

$u(t)$ - analog signals;

K_p - Percentage gain;

T_I - Integration time constant;

T_D -Differential time constant.

For Laplace transfer function for:

$$G(s) = \frac{U(s)}{E(s)} = K_p \left(1 + \frac{1}{T_i s} + T_d s\right) = K_p + K_i \frac{1}{s} + K_d s \quad (14)$$

There are some faults in the positional PID control arithmetic, first, it must to finish computing one $u(n)$, adding $n+3$ times and multiplying 3 times, as well it will be increased following the time; second, it should to hold back the figure of $e(t)$ which come from sampling time, and it will occupied more memory space. This article use control increment method.

$$\begin{aligned} \Delta u(n) &= u(n) - u(n-1) \\ &= K_p \{ [e(n) - e(n-1)] + K_i e(n) + K_d [e(n) - 2e(n-1) + e(n-2)] \} \end{aligned} \quad (15)$$

Where : K_p -proportional coefficient, $K_p = 0.6K_m$;

$$K_i \text{ -integral coefficient, } K_i = \frac{K_p T}{0.5T_m}$$

$$K_d \text{ -differential coefficient, } K_d = 0.125K_p T T_m ;$$

T_m - system constant amplitude oscillation gain;

K_m - oscillating period;

T - system sampling period.

$$\begin{aligned} \text{And } \Delta u(n) &= K_p(1 + K_i + K_d)e(n) - K_p(1 + 2K_d)e(n-1) + K_p K_d e(n-2) \\ &= Ae(n) - Be(n-1) + Ce(n-2) \end{aligned} \quad (16)$$

Where: Δu -PID increment of adjustment;

$e(n)$ -once before error;

$e(n-1)$ -the first two times error;

$e(n-2)$ -the first three times error.

$$A = K_p(1 + K_i + K_d) = K_p \left(1 + \frac{T}{T_i} + \frac{T_d}{T}\right)$$

$$B = K_p(1 + 2K_d) = K_p \left(1 + \frac{2T_d}{T}\right)$$

$$C = K_p K_d = \frac{2K_p T_d}{T} \quad (17)$$

System uses a tuning method named Nierkesi, turn the time integral coefficient of the controller to the largest ($T_i = \infty$), and zero the differential time coefficient ($T_d = 0$), adjusting the proportional gain increased gradually from 0 to increases gradually, amplitude of oscillation, and then write down the oscillating period $K_m = 0.955$, the system constant amplitude oscillation gain $T_m = 0.31s$, the system sampling period $T = 50ms$, and we can get:

$$K_p = 0.573, \quad K_i = 0.1848, \quad K_d = 0.0011;$$

$$A = 0.6795, \quad B = 0.5742, \quad C = 0.0006.$$

5 Simulation of valve-controlled motor velocity control system

Simulink is an interactive model input and simulation environment launched by Math Works company, with a relatively independent function and use, it with the user interaction interface is based on Windows graphics programming method. Simulink is a can of dynamic system model, simulation and analysis package, it allows users to draw a series of charts to finish model work, and dynamically operation, the applicable to model of discrete and continuous, the mixture of both linear and nonlinear system, also support has a variety of sampling rate multi-rate system of Simulink provides customers with module base varied function module and is convenient for the user to the model simulation and analysis.

According to the established mathematical model, get valve control motor speed system PID control simulation charts, as fig.4 shows:

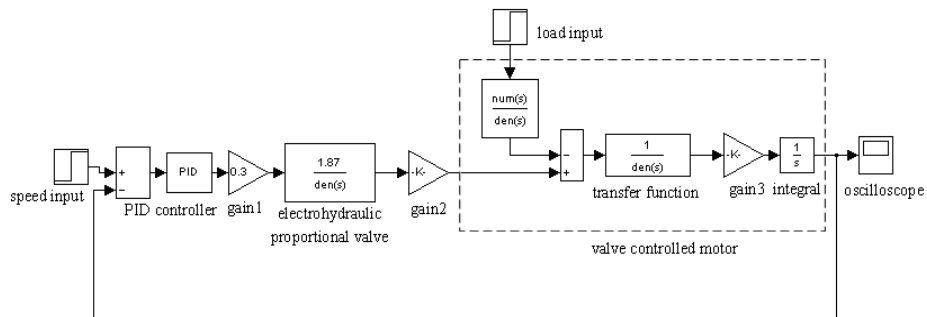

Fig. 4 .simulation charts of valve controlled motor system

Using P and PI control system speed simulation curve respectively as shown in figure 5 and figure 6, fig. 5 show that P control system overshoot is 78.38%and adjust time is 6.3 s, fig.6 show that PI control system overshoot is53.21%and adjust time is 3.75 s.

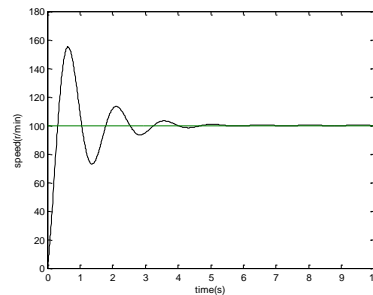
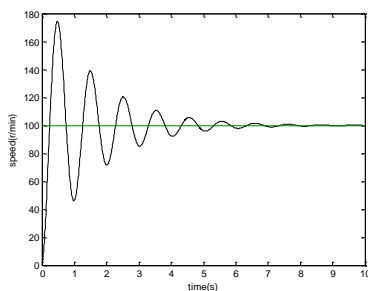

Fig. 5. P control system speed curve **Fig.6** .PI control system speed curve

PID control system speed simulation curve fig. 7 shows that PID system overshoot is 27.92%and adjust time is 1.7 s. The test results show that the variable-rate fertilization control system with PID controller can restrain the vibration and decrease the intensity effectively. The PID controller is superior to the general P controller in the settling time, and the effect of control and adaptability, which accords with the design demand of the Variable-Rate Fertilization Control system completely.

6 Tracing performance test

Test verified system track results, test conditions: variable fertilization test bed; computer; BOPU data acquisition instrument; variable fertilization software. Step response curve of PI and PID system are respectively showed in fig. 9 and fig. 10 in the condition that the sampling frequency is 1KHz and given transmission ratio is 0.2. Fig. 9 show that overshoot of PI system is 31.5% and adjust time is 5.3 sec , however

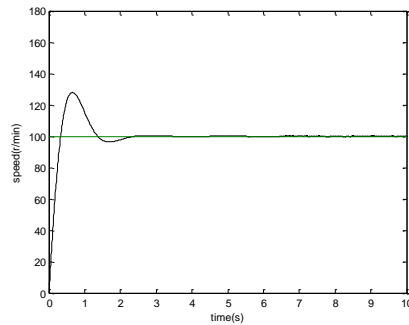

Fig.7. PID control system speed curve

fig. 10 show that PID system overshoot is %, and adjust time is 2.7 s. The test results show that the variable-rate fertilization control system with fuzzy controller can restrain the vibration and decrease the intensity effectively, and the amplitude is reduced by 25%~30%. The fuzzy PID controller is superior to the general PID controller in the settling time, and the effect of control and adaptability, which accords with the design demand of the Variable-Rate Fertilization Control system completely.

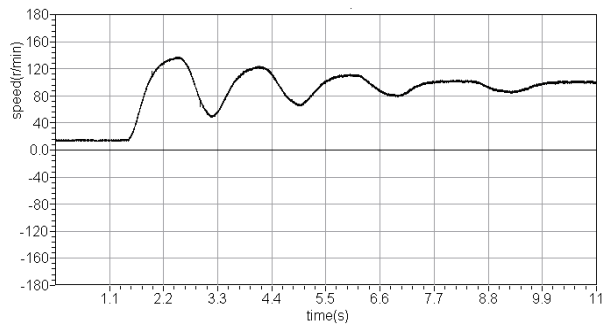

Fig.9. PI system step response simulation

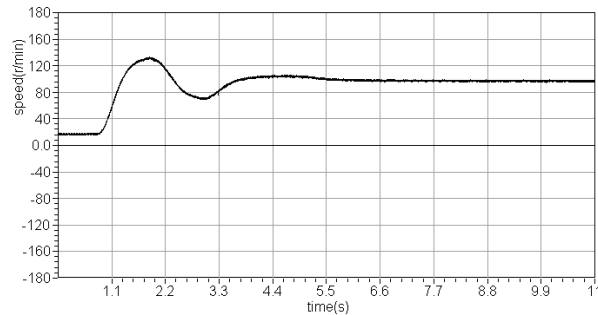

Fig.10.PID system step response simulation

7 Conclusions

Use of MATLAB/SIMULINK simulation tools to achieve modeling of the variable rate fertilizing control system, the system with PID control strategy has high steady-state precision, fast dynamic response, small overshoot, strong anti-interference capability, can get good results. Carry the performance tests in the self-developed control system of variable-rate fertilization, test results and simulation results are basically consistent and achieve the expected goal.

8 Acknowledgment

Funds for this research was provided by national science and technology support plan major projects of china (2012BAD04B01, 2011BAD20B03, 2011BAD20B06), Science and Technology Project of education department of Heilongjiang province (12511355). The corresponding author is Prof. Ji Jianwei .

References

1. HU Jianjun, YANG Shangping, ZHANG Lunzhao, et al. Construct and Study Mathematical Model of Direct-acting Proportional Control Valve Hydraulic Pressure Motor[J]. Machine Building Automation, 2009, 38(3): 141-143.
2. Wang Yanli Study on and Identification of Electro-hydraulic Proportional valve-Motor System[D]. Chang'an University, 2007.
3. Zhang Hui, Li Shujun, Zhang Xiaochao, et al. Development and performance of electro-hydraulic proportion control system of variable rate fertilizer[J]. Transactions of the CSAE, 2010, 26(2): 218-222. (in Chinese with English abstract)
4. Wang Xiu, Zhao Chunjiang, Meng Zhijun, Design and experiment of variable rate fertilizer applicator. Transactions of the CSAE, 2004, 20 (5) :114-117.

5. Li Aichuan, Wang Xi, Wang Zhiqiang et al. Research about Variable Rate Fertilization Closed-loop Control System of Electro-hydraulic Speed[J]. Chinese Agricultural Science Bulletin. 2009,25(07): 272 -275.
6. Shao Lim in, W ang X iu, Niu Xiao ying, et al .Design and experiment on PLC control system of variable rate fertilizer[J].Transactions of the Chinese Society of Agricultural Machinery, 2007, 38(11): 84-87.
7. Fu Weiqiang, Meng Zhijun, Huang Wenqian, et.al. Variable rate fertilizer control system based on CAN bus[J]. Transactions of the CSAE, 2008, 24(Supp.2):127-132.
8. Chen Liping,Huang Wenqian,Meng Zhijun. Design of Variable Rate Fertilization Controller Based on CAN Bus[J].Transactions of the Chinese Society of Agricultural Machinery, 2008, 39(8):101-105.
9. Zhang Hui, Li Shujun, Zhang Xiaochao, et al. Development and performance of electro-hydraulic proportion control system of variable rate fertilizer[J]. Transactions of the CSAE, 2010, 26(2): 218-222.
10. Meng Zhijun, Zhao Chunjiang, LiuHui, Development and performance assessment ofmap-based variable rate granule application system. Journal of JIANGSU UNIVERSITY, ,2009,30(4):338-342.
11. Fu Weiqiang, Meng Zhijun, Huang Wenqian, et.al. Variable rate fertilizer control system based on CAN bus[J]. Transactions of the CSAE, 2008, 24(Supp.2):127-132.
- 12.Liang Chunying, Yi Shujuan,WangXi. PID Control Strategy of the Variable Rate[J].Transactions of the Chinese Society of Agricultural Machinery Fertilization Control System, 2010, 41(7): 157~162.
13. Shao Limin, Wang Xiu, Niu Xiaoying, et a.l Design and experiment on PLC control system of variable rate fertilizer[J].Transactions of the Chinese Society for Agricultural Machinery, 2007, 38(11): 84~87.
14. Gu Yuxue, Yuan Jin, Liu Chengliang. FIS-based method to generate bivariate control parameters regulation sequence forfertilization[J]. Transactions of the CSAE, 2011, 27(11): 134-139.
15. Yuan Jin Liu Chengliang Gu Yuxue. Bivariate Fertilization Control Sequence Optimization Based on Relevance Vector Machine. [J].Transactions of the Chinese Society of Agricultural Machinery,2011(42)s:184-190.
16. NIU Xiang jie,WANG Yujie,TANG Jian. Optimization Parameters of PID Controller Parameters Based on Genetic Algorithm[J]. Computer simulation, 2010,11:180-183.
17. Sun Limin, Wang Fulin .Research on variable rate seeding and fertilization technology[J]. Journal of Northeast Agricultural University, 2009,40(3): 115-120.
18. ZHAO Shengdun,JI Wang. Iterative learning control of electro-hydraulic proportional feeding system in slotting machine for metalbar cropping [J].International Journal of Machine Tools&Manufacture,2005,45(7):923-931.
19. WU Yonghong,ZHANG Dehua,DUAN Suolin.Iterative learning control on electro-hydraulic position servo systems of the pump-controlled cylinder [J].Journal of Taiyuan University of Science and Technology,2006,27(4):277-280.
20. QUAN Long,LI Fenglan,WANG Xiang. Study on the efficiency of differential cylinder system driven with servo motor and constant pump[J].Proceedings of the CSEE,2006,26(8):93-98.
21. Niu Xiaoying,Qian Dongping Wang Xiu. ,et al. Research on control system of variable rate fertilizer applicator in precision agriculture based on NDVI [J]. Journal of Agricultural University of Hebei. 2005, 28(2):94-98.
22. ZHANG Youwang,GUI Weihua. Compensation for secondary uncertainty in electro-hydraulic servo system by gain adaptive sliding mode variable structure control[J]. Journal of Cent South University Technol,2008,15(2):256-263.
23. TIAN Yuan,WU Shenglin. Theoretic analysis and experiment of valveless electro-hydraulic servo system[J].China Mechanical Engineering, 2003, 14(21):1822-1823.

24. Liu J K,Liu Q,Er L J.Zero phase error real time control for flight simulator servo system[J].Chinese Journal of Mechanical Engineering, 2004,17(1): 132-135.
25. Lin Changhua1,Tang Qunfeng, Tang Shumei. The research and application prospect of precise fertilization techniques[J]. Journal of South China University of Tropical Agriculture. 2006, 12(2):76-79.
- 26 Camp, C.R.Sadler, E.J.Evans, D.E. Variable-rate, digitally controlled metering device[J]. Applied engineering in agriculture. 2000,16 (1): 39-44.
- 27 Hamson, S.J. Smith, L.A.Hanks, J.E. Evaluation of Application Accuracy and Performance of a Hydraulically Operated Variable-Rate Aerial Application System[J]. Transactions of the ASABE. 2009 ,52, (3):715-722.