



HAL
open science

Timed Coloured Petri Nets for Performance Evaluation of DSP Applications: The 3GPP LTE Case Study

Laura Frigerio, Kellie Marks, Argy Krikelis

► **To cite this version:**

Laura Frigerio, Kellie Marks, Argy Krikelis. Timed Coloured Petri Nets for Performance Evaluation of DSP Applications: The 3GPP LTE Case Study. 19th IFIP WG 10.5/IEEE International Conference on Very Large Scale Integration (VLSI-SoC), Oct 2008, Rhodes Island, India. pp.114-132, 10.1007/978-3-642-12267-5_7. hal-01054268

HAL Id: hal-01054268

<https://inria.hal.science/hal-01054268v1>

Submitted on 5 Aug 2014

HAL is a multi-disciplinary open access archive for the deposit and dissemination of scientific research documents, whether they are published or not. The documents may come from teaching and research institutions in France or abroad, or from public or private research centers.

L'archive ouverte pluridisciplinaire **HAL**, est destinée au dépôt et à la diffusion de documents scientifiques de niveau recherche, publiés ou non, émanant des établissements d'enseignement et de recherche français ou étrangers, des laboratoires publics ou privés.



Distributed under a Creative Commons Attribution 4.0 International License

Timed Coloured Petri Nets for Performance Evaluation of DSP Applications: the 3GPP LTE Case Study

Laura Frigerio¹, Kellie Marks², Argy Krikelis²

¹Dipartimento di Elettronica e Informazione
Politecnico di Milano
Milano, Italy
laura.frigerio@polimi.it

²European Technology Center
Altera Corporation
High Wycombe, United Kingdom
{kmarks,akrikeli}@altera.com

Abstract. In this paper we propose the use of Timed Coloured Petri Nets for the Performance Evaluation of Hardware/Software systems for DSP applications. Complex systems on chip, composed by hardware and software parts, are often required to meet strict timing constraints, both in terms of throughput and latency. However, the verification of the suitability of a system configuration can usually be performed only after the integration of the hardware and software components, when design modifications and optimizations are particularly expensive. This article proposes a framework to evaluate the performance of HW/SW systems in which Timed Coloured Petri Nets can be exploited in the early phases of the design. The framework is tested by modelling the Physical Uplink Shared Channel (PUSCH) bit-rate receiver portion of 3GPP (3rd Generation Partnership Project) LTE (Long Term Evolution) standard, the next generation of 3G wireless systems.

Introduction

Complex DSP systems nowadays include heterogeneous hardware and software components, like multithreaded CPUs, hardware accelerators and fast interconnections. Due to the systems complexity and to the time-to-market pressure, IP (Intellectual Property) based methodologies are often used to reduce the development time and enhance module reuse [1].

Embedded systems for DSP applications have strict constraints on performance that designers try to meet by efficiently combine pre-verified IPs and ad-hoc implementations. However, the evaluation of the system performance, in order to verify the system throughput and latency, is usually very difficult due to both the high degree of concurrency and the heterogeneity of modules. The system verification can

therefore be completed only in final stages of the development, when the hardware and software modules are integrated into the system. At this stage however, very little flexibility is left for optimizations and problems in meeting the required constraints lead to expensive and time consuming modifications of the systems.

For this reason this paper presents a framework for the early evaluation of the system performance, that can be used to tune and improve the system design before the actual integration of the components takes place.

Different methods can be used to evaluate the performance of a system and can generally be classified in 1) simulation techniques and 2) formal models. Simulation techniques provide information on the system behaviour by tracing the results obtained when applying stimuli to a system model. Pure simulative approaches using for example the SystemC Library have been applied in [2] and [3]. However, simulation approaches alone, cannot provide information on system properties like the absence of deadlocks or system bottlenecks.

Formal models describe the system in a mathematical form and can provide accurate information on its behaviour. Example of formal models used for performance evaluation are Markov processes [4], Queuing Networks [5] and Timed Petri Nets [6]. In this paper, we consider Timed Petri Nets since they are especially suited for describing HW/SW systems in general and DSP applications in particular. First of all, Petri Nets are an intuitive and powerful way to define concurrent and asynchronous processing, useful to describe HW/SW systems. Moreover, with respect to other methods that consider Stochastic timing models only, Petri Nets allow to consider both Deterministic and Stochastic timing models. In DSP applications, where IP blocks are often used in the design, the availability of Deterministic times allows to build accurate models, since the exact timing required to process input data is often available (e.g. number of clock cycles of an hardware module) and can be considered in the model. Finally, several tools are provided to support both the extraction of analytical properties and the simulation of Petri Nets models.

Petri Nets have been used to model a broad range of applications (refer to [7] for examples of industrial use). They have also been used to model digital hardware (many references can be found in [8]). In the context of SoC, the description of communication infrastructure [9] and the formal verification of the implementation [10] have been considered. In this paper, Timed Coloured Petri Nets (TCPN) are used to evaluate the Performance of Hardware/Software systems in early phases of the system design. The use of Coloured Petri Nets enriches the timing description with high level elements, such as complex data types and hierarchy decomposition.

Differently from other works on HW/SW systems based on Petri Nets (like [11], [12], [13]), Petri Nets are not used to support the system design or partitioning, but to perform a rapid Performance Evaluation at IP-blocks granularity, by seamlessly integrate HW and SW models.

The rest of the paper is organized as follows. The next Section provides the formal definition of the Timed Coloured Petri Nets (TCPN) used thorough the paper. A framework to model a HW/SW system with Petri Nets is then introduced. The following Section describes the 3GPP LTE application, used as a case study to verify the proposed framework. The reference HW/SW platform is then presented followed by the description of the mapping of the LTE application on it, using the Petri Net framework previously introduced. The following Section compares the results

obtained by applying the Petri Net model to those obtained by the integration of the hardware and software systems. Finally, last Section concludes the work.

Formal definitions

Coloured Petri Nets are an extension of classical Petri Nets, introduced by C. A. Petri [14]. A Coloured Petri Net is defined [15] as a nine-tuple $CPN=(\Sigma, P, T, A, N, C, G, E, S)$, where:

1. Σ is a set of non-empty types, also called colour sets.
2. P is a finite non-empty set of places.
3. T is a finite non-empty set of transitions
4. A is a finite non-empty set of arcs such that: $P \cap T = P \cap A = T \cap A = \emptyset$
5. N is a node function, defined from A into $P \times T \cup T \times P$, which maps each arc into a tuple where the first element is the source node and the second element is the destination node.
6. C is a colour function, defined from P into Σ , which means that C maps the place p to a colour set;
7. G is a boolean expressions, called guard function, which maps the transition t to the Boolean function needed to be evaluated as “true” to enable the transition;
8. E is an arc expression function. A transition is enabled if there exists, for each input arc, a token in the input place bounded to that arc.
9. S is the initialization function, which specifies the initial state of the Petri Net.

The initial marking M_0 assigns to the place the initial (coloured) Tokens. For a formal definition, refer to [15]. In Timed Coloured Petri Nets, transition occurrences fire in ‘real-time’ associated with each occurrence of each transition. In this paper we consider deterministic (D-times) nets, where the times are deterministic [6]. Any enabled transition starts its firing in the same instant in which it becomes enabled.

Each firing can be considered as a three phase event; first, the (coloured) tokens are removed from the input places as indicated by the arc functions of the firing occurrence, the second phase is the firing time period, and when it is finished, (coloured) tokens are deposited to output places as indicated by the arc functions of the firing occurrence. If a transition occurrence becomes enabled while it is firing a new independent firing cycle begins.

Formally, a Timed Coloured Petri Nets is a couple $TCPN = (CPN, f)$, where:

1. CPN is a coloured Petri Net, $CPN=(\Sigma, P, T, A, N, C, G, E, S)$.
2. f is a firing-time function which assign the firing time to each occurrence colour of each transition of the net, $f: T \times C \rightarrow R^+$.

Modelling with Petri Nets

A typical DSP application, can be decomposed in a sequence of functions elaborating data. Each function is intended as an operation, or set of operations, to be applied to a data unit. A simple representation is given by the application graph (Figure 1a) where circles identify functions and arcs are used to specify their dependencies. If there are different data going through different paths, an extension of the previous representation is considered using different types of arcs (Figure 1b).

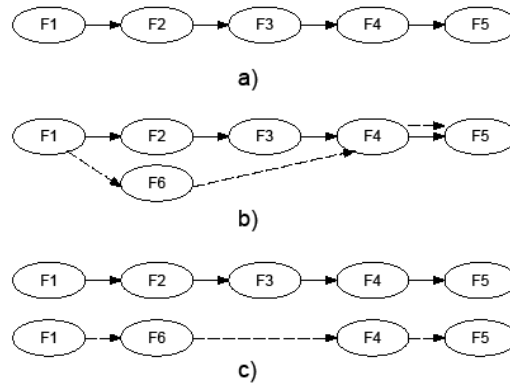

Fig. 1. Application graphs for a sequence of $F_1; F_2; \dots; F_m$ functions

However, this situation can be represented as the first one by considering two separated graphs like in Figure 1c. Each function is executed by an executor that can be a processor (if the function is implemented in software) or a hardware module (if the function is implemented in hardware). There can exist multiple instances of the same executor, in order to satisfy the performance requirements. In the following, we indicate as *resource class* (or in short *resource*) a set of identical executors, and as *availability* the number of instances of executors in the same resource class. For example, we can compute a DFT (function) by the use of a DFT hardware module, or a processor executing a DFT software algorithm (resources). Let us consider, for performance reasons, to include in the design two DFT hardware modules in order to be able to process two requests of the DFT function in parallel. In this case the availability of the resource DFT is equal to two.

More formally, given a set of functions F and a set of resources R we define for each function a mapping m on the resource on which it is executed, $m : F \rightarrow R$. The execution of a function f_i on a resource r_j requires a certain amount of time t_{ij} . Values t_{ij} are known if the design process is based on IPs (Intellectual Property) or can be estimated on the basis of previous and similar implementations. In case of variability a timing distribution or an average time value can be considered.

Starting from these definitions, we can generate the Timed Coloured Petri Net modelling the application, as represented in Figure 2 for a simple example. For each function and each resource we introduce respectively two places (an F-Place and an R-Place). We also add a Q-place for each function to represent the queue of data

waiting to execute the function. The output transition of the F-Place is annotated with time t_{ij} and the initial marking of each R-Place is defined by its availability. F-Places are connected according to the application graph; if a resource is shared by different functions, a single R-Place is used and appropriate arcs are used to connect different F-Places to the same R-Place.

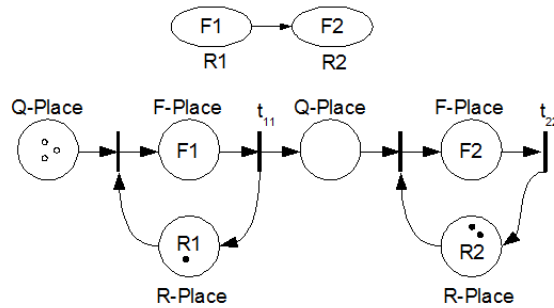

Fig. 2. TCPN generated from an application graph, where the availability of R1 is equal to 1, the availability of R2 is equal to 2. D-tokens in the Q-Place represent three data units waiting for the execution.

Coloured tokens are used to represent both the resource availability (R-Tokens contained in R-Places) and the data units (D-Tokens contained in F-Places and Q-places). The type of D-Tokens is defined according to the parameters needed to determine the system execution. For example, a D-Token can contain an integer value corresponding to the input dimension of the DFT function, that affects the time it takes to execute that function.

In the following we introduce some extension of the presented model.

Multiple data management

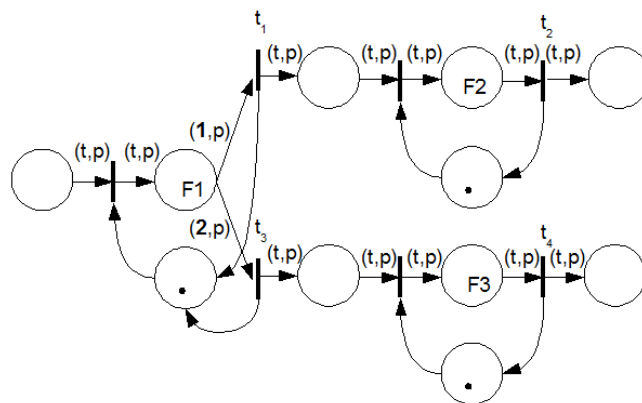

Fig. 3. TCPN for multiple data management

If there are data that take different paths, we could exploit the availability of expressions and bindings in CPN to represent this situation. For example, in Figure 3 the D-Token contains two fields, and the value of the first one is used to select the path the token follows in the net.

Pipeline hardware

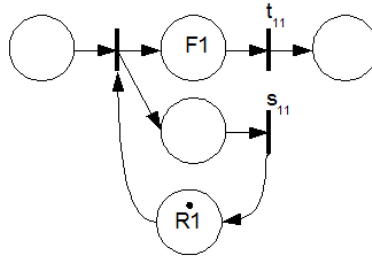

Fig. 4. TCPN to model a pipelined hardware resource

A pipelined hardware resource can accept a new data in input every clock cycle (stage time). The execution is completed after the total number of clock cycles required by the function. The execution on a pipelined resource is therefore characterized by two values: a time t_{ij} representing the total time to execute the function and a time s_{ij} representing the stage time. The stage time is equal to one considering the common definition of pipeline, but in a more generic module it is a value greater than one and smaller than t_{ij} .

An example is represented in Figure 4.

Data ordering

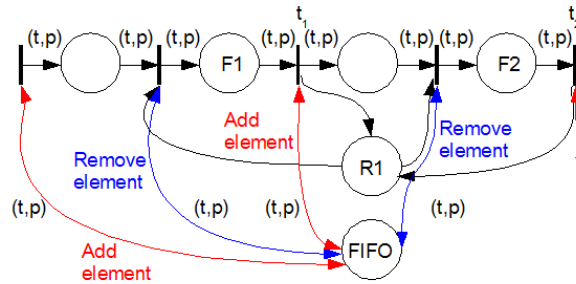

Fig. 5. TCPN to model data ordering

If data ordering must be considered, we can exploit the use of FIFOs in CPN [16]. For example, Figure 5 represents two functions executing on the same resource, where the requests for the use of the resource are queued in a FIFO. An additional place, that

contains one token of type FIFO, is introduced. Each time an element has to be added, the FIFO token is removed, and replaced with an updated version with the new element at the end. Each time an element has to be extracted, the FIFO-token is removed, and replaced with an updated version without the first element.

Design granularity

The concepts of functions and resources are not necessary restricted to IPs granularity, but can be adapted according to the specific needs when modelling the application. We can model, for example, the internal behaviour of a hardware module or take into consideration the availability of memory space as an additional resource to perform an operation. Example of finer granularity are provided in the rest of the paper.

Introduction to the LTE application

This Section gives an overview of the LTE application, and explains the reasons for needing to model the system using the Petri-net approach. After providing an introduction on the LTE main features, we highlight the LTE criticalities, in particular latency requirements and complexity. The presence of these criticalities constitutes a major obstacle in evaluating a HW/SW solution before its actual implementation. The following Sections show how Petri Nets can help doing this type of evaluation.

Application Description

3GPP Long Term Evolution (LTE) is next generation of 3G networks aimed at delivering lower latencies, with greater capacity and throughput. It is based on OFDM in the downlink and Single Carrier Frequency Division Multiple Access (SCFDMA) in the uplink.

LTE has evolved from previous 3GPP standards with each evolution providing greater network throughput and lower latencies. The first 3GPP standard, known as release 99, used a radio access technique called Wideband Code Division Multiple Access (WCDMA). It could provide data rates of up to 384kbps in the downlink and 384kbps in the Uplink with round-trip latencies of approximately 150ms. The next two 3GPP releases, High Speed Downlink Packet Access (HSDPA) and High Speed Uplink Packet Access (HSUPA), improved the data rate to 14.4Mbps in the Downlink and 5.7Mbps in the Uplink. The round-trip time reduced from approximately 100ms to approximately 50ms respectively. In Release 7 or HSPA+ (High Speed Packet Access +) a new multiple antenna technique known as MIMO (Multiple Input Multiple Output) was introduced, which improved the data rates by using multiple transmit antennas to carry parallel streams of data which are then extracted separately in the receiver. This technique improved the data rates to 28/42Mbps (depending on the number of antennas used) in the downlink and 11Mbps in the uplink.

Release 8 or 3GPP LTE, represents a new generation of wireless techniques by moving away from WCDMA, and employed OFDMA (orthogonal frequency division multiple access) in the Downlink and SC-FDMA in the uplink. Higher data rates (up to 172Mbps in the downlink and 86Mbps in the Uplink) are achieved in LTE through the efficient use of the available spectrum by the use of higher order modulation schemes (up to 64QAM) and MIMO techniques. In addition to this, LTE provides greater flexibility for network operators allowing variable spectrum allocations up to 20MHz, and for the mobile devices, the use of SC-FDMA in the uplink means greater terminal or mobile efficiency and longer battery life.

The uplink bit-rate receiver portion (Physical Uplink Shared Channel - PUSCH) of the LTE system has been chosen to illustrate the use of Petri-net models to evaluate the performance of the system. An overview of the PUSCH may be found in [17], and a technical specification of the PUSCH including the processing steps required may be found in [18].

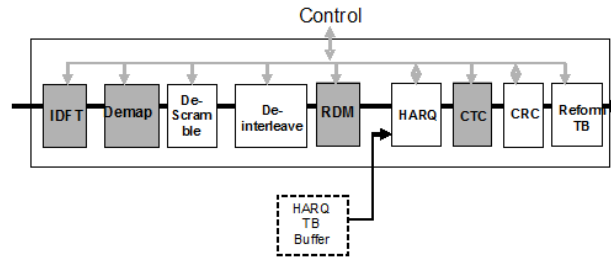

Fig. 6. Functions composing the LTE application

Figure 6 shows basic processing steps of the SC-FDMA uplink bit-rate receiver. The shaded blocks have been considered, for illustration purposes, to present the use of Petri-net models for complex DSP systems.

Table 1. Blocks and parameters of the LTE uplink application

Block	Function	Parameters affecting functionality/latency	Ex. Parameter Ranges
IDFT	Transform Precoding	Number of resource Blocks	12-1296
Demapper	Demodulation	Modulation scheme	QPSK, 16QAM, 64QAM
Rate De-Matcher	Channel coding	Code block size, Coding rate, Filter bits, Redundancy version	40 – 6144 1/9 – 5/6 0 – 64 1 – 4
CTC (Turbo)	Channel coding	Code Block size	40-6144

Blocks are characterized by parameters that can affect not only the functionality but also the latency of the block. Table I gives examples of the different parameters and the range of values the parameters may take.

Users are allocated a number of resource blocks for transmission. The modulation scheme and coding rate determine the number of data-bits transmitted during the slot.

Due to the low latency target for LTE, the uplink SC-FDMA link budget is in the order of 1ms. Meeting this latency target is a key requirement of the system, and requires careful analysis of the latency of the system. The number of possible parameter combinations and the interaction between the latency and throughput of each block in the system makes this a difficult task to perform without a tool to model these interactions.

In the following the main features of each block being modelled are summarized.

IDFT

In the transmitter the OFDM symbol is “orthogonally spread” onto the subcarriers using a Discrete Fourier Transform (DFT). The number of subcarriers that it is spread across represents the number of resource blocks allocated for the users transmission, and is equivalent to the DFT size.

In the receiver the IDFT is used to retrieve the DFT-Spread OFDM symbol transmitted across the air interface. The IDFT accepts a sequence of complex data samples and produces a complex output sequence of the same length.

Demapper

The symbol demapper (demapper) translates the complex data samples produced by the IDFT into soft-valued bits. Each bit in the symbol is given a log-likelihood ratio value based on the exact position of the received symbol in the IQ plane.

The soft-decision values depend on the modulation scheme used (and therefore the constellation pattern produced). Possible modulation schemes used for LTE Uplink Shared Data channel (PUSCH) include QPSK, 16QAM and 64QAM.

Rate De-Matcher

The rate dematcher maps the size of the data in the transport layer onto the appropriate physical layer resources by inserting or removing redundancy.

The rate dematcher takes soft-value bits as input from the symbol demapper and produces systematic (S) and parity bits (P1, P2) for the turbo.

CTC (Turbo decoder)

The turbo decoder is used to perform forward error correction of the input data stream by utilizing the redundancy in the encoded data stream. Turbo codecs have become the coding technique of choice in many communication systems due to their near Shannon limit error correction capability.

The turbo decoder takes the systematic and parity bits produced by the rate dematcher and produces a stream of bits, representing the recovered data bits. The turbo block operates on the code blocks produced by the rate dematcher

Understanding LTE Latency requirements

Providing low network latency is a key network metric for LTE systems. Services such as voice over IP, video conferencing and network gaming applications are

particularly sensitive to latency as it has a major impact on the user's experience of these services.

To provide this reduction in latency, LTE employs two main mechanisms [21]

1. Reducing the Transmission Time Interval (TTI). LTE will use a TTI of 1ms, 50% less than the previous generation wireless standard HSUPA (High Speed Uplink Packet Access).
2. Faster HARQ or retransmission processes for lost or damaged blocks of data. By providing faster feedback mechanisms, LTE will enable the transmitter to resend the lost blocks earlier, making the radio transmission more efficient.

The LTE user-plane latency is defined in [21] as: "the one-way transit time between a packet being available at the IP layer in either the UE/RAN edge node and the availability of this packet at IP layer in the RAN edge node/UE. The RAN edge node is the node providing the RAN interface towards the core network", where UE stands for User Equipment, or the mobile device and RAN stands for Remote Access Network, referring to the eNB (Evolved Node B) or base station. The requirement for the LTE user-plane latency is 5ms.

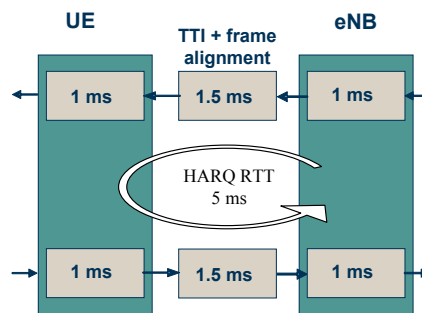

Fig. 7. User Plane Latency components in LTE[22].

This latency figure contains several identifiable latency components as shown in Figure 7. The times shown in the Figure are a lower bound as to what is achievable with LTE, as they assume that a single user system, transmitting small IP packets (0 byte payload with IP headers). This implies that the network is not loaded and that there are no delays due to queuing or scheduling. In addition to this, the HARQ round trip time must be 5ms.

For eNB providers, this means that providing these latency targets are met, a trade off may be made between the Uplink and Downlink processing times in the eNB. It may be possible for the provider to use only 0.6ms for the DL processing time leaving an extra 0.4ms for the UL processing. Since the UL processing is significantly more complex than the DL processing such an analysis might prove valuable, requiring careful analysis of the latency in each individual components.

Understanding LTE complexity

The LTE specification is characterized by an increase in the complexity of the signal processing over other OFDM systems, such as WIMAX. LTE requires high data rate forward error correction, Multiple Input, Multiple Output antenna techniques, and in the uplink, SC FDMA requires an extra stage of processing to transform from the frequency domain to the time domain. This additional complexity in the signal processing, is also matched by commensurate increase in complexity of the control required to manage the signal processing elements. Therefore the LTE system is highly suited for a HW/SW approach whereby the complex data processing is done in HW, and the control is performed in SW.

Reference architecture

The reference architecture considered to implement the LTE system is based on the Altera Hardware/Software solution for high performance datapath applications [20]. The solution is based on a combination of a multithreaded soft processor and hardware accelerators.

The overall processing is based on an asynchronous execution paradigm triggered by task (i.e. software process) and event (i.e. hardware accelerated process) requests. The overall system is composed of the multithreaded processor with supporting control and interfaces that manage the communication with dedicated accelerator modules through buses and queues. The details of the Hardware/Software interaction and communication are hidden from the applications developer and Hardware/Software communication introduces an almost negligible latency of very few clock cycles.

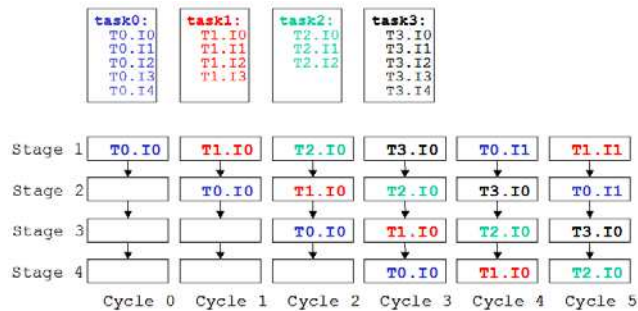

Fig. 8. Instruction interleaving

The soft processor can execute 8 threads simultaneously by means of a simultaneous multithreading. In a traditional multithreading, a new thread is executed when the previous thread stalls; however, in this design, instructions corresponding to 8 different threads are mixed (interleaved) in the pipeline. This allows to avoid the overhead for thread switching and pipeline stalls since whatever hazard in a given

thread instruction is resolved before the next instruction of the same thread is executed. The execution scheme is depicted in Figure 8 for an exemplified pipeline with 4 stages. One of the advantages of this approach is that the software execution time becomes deterministic given an execution path, since all the sources of indeterminism are avoided. Hazards and context switching introduce no penalty, and no cache is used in the system (in the great majority of datapath applications data and program code are limited in size and can be stored directly on the chip).

For each independent flow a unique ID is assigned (PID). The number of PIDs is defined during the hardware synthesis of the soft processor and it can be adjusted to suit the application performance requirements.

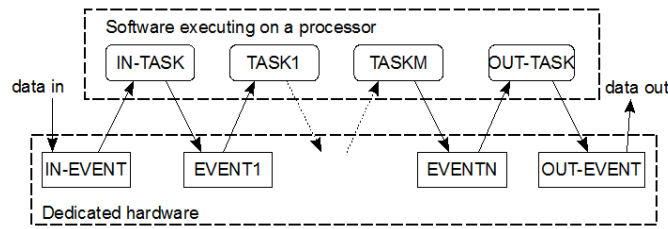

Fig. 9. Execution Flow on the Hardware/Software Altera architecture for datapath processing

A typical processing flow combines Tasks that are executed in software and Events executed by dedicated hardware blocks, as schematically depicted in Figure 9. The inherent parallelism of the multithreaded processor and the multiplicity of dedicated hardware blocks allows for several independent flows to be processed concurrently.

Architecture modelling with TCPN

Since the hardware and software parts can generally run at two different frequencies F_{hard} and F_{soft} , we consider a reference frequency F_{ref} . The modelling of this architecture with a Petri Net can be done as following:

- **Multithreading.** The execution of eight threads on the same processor at frequency F_{soft} , with the instruction interleaving described in the previous Section, is functionally equivalent to the execution of eight threads on eight identical processors each one running at a frequency $F_{soft}/8$. The multithreaded processor is therefore represented with a resource class having availability equal to eight and frequency equal to $F_{soft}/8$.
- **Timing.** Both hardware and software times can be considered as deterministic. Each function f_i executing on a resource r_j is associated with the execution ticks t_{ij} computed as:
 - $t_{ij} = (\text{Num. of instructions} * F_{ref}) / (F_{soft}/8)$ (SW).
 - $t_{ij} = (\text{Num. of clock cycles} * F_{ref}) / (F_{hard})$ (HW).
- **Number of PIDs.** An additional place (PID-Place) is added, having as initial marking a number of R-Tokens equal to the number of PIDs. Each time a new block of data enters the system an R-Token is consumed from the PID-Place and is

produced when the block of data exits the system. In a more generic architecture this place can be used to represent the maximum depth of queues for Hardware/Software communications.

- Communication. Since the overhead for the Hardware/Software communication is negligible, it is not modelled. In a more generic architecture, if the communication introduces substantial overhead, this can be represented exploiting the same framework used for the rest of the system (for example, a data transfer between two modules is the function and a bus is the resource).

Mapping of the LTE application on the platform

The implementation of the LTE application has been organized as follows. The majority of the complex DSP processing is done with hardware accelerators; this includes IDFT, Symbol Demapper, Rate De-matcher, and Turbo. The control of the data flow through these blocks, and the configuration of the blocks with the relevant parameters (see Table I) is done using software running on the threads in the processor.

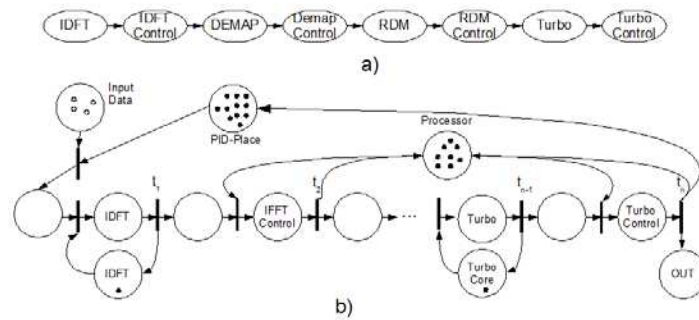

Fig. 10. a) Application Graph for the LTE application, b) Sketch of the TCPN associated to the LTE application graph

Figure 10 represents the application graph and a sketch of the correspondent TCPN. Coloured tokens that flow into the net contain all the information needed to influence the system evolution, in particular timing and computational path. The most important parameters are: pid, number of resource block, modulation scheme, coding block size, coding rate, filter bits, redundancy version and constitute the fields characterizing the tokens. Other parameters (like the number of subcarriers or the number of symbols per TTI) constitutes system settings and are therefore associated to the system model instead of being stored into the tokens. The times associated to the transitions depend on the number of hardware clock cycles and software instructions required to process the functions. For each function composing the system appropriate timing has been considered, often dependent on the parameters cited before.

In the LTE system where there are multiple complex IP Blocks interacting, it is often necessary to buffer blocks of data before the processing. This may be because the function requires all data present in order to calculate the result or it may be done to achieve the required throughput of the system.

In order to obtain a more accurate model, the behaviour of the hardware modules have been described with a finer grain of detail, by decomposing the functions in more steps and considering additional resources like buffers and memories.

In the following, we present the Petri Nets schemes developed for the blocks of the LTE architecture, highlighting the strategies used to enhance the accuracy of the model.

IDFT

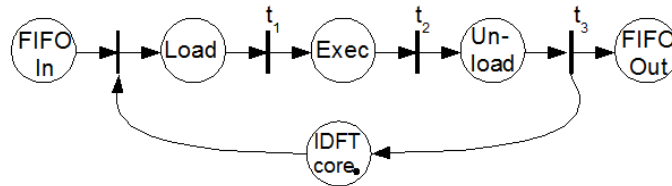

Fig. 11. Petri Net structure of the IDFT block

The IDFT is characterized by the loading, executing and unloading phases. For each phase, the computing time is function of the resource block size. The three phases must be completed for each data before the computing can start for a new one. The situation is represented in Figure 11 where the computing is decomposed in three steps and the R-Place associated with the IDFT core is connected respectively to the transition entering the first phase and the transition exiting the last phase.

Demapper

The symbol demapper module is responsible for transforming the IQ samples representing the constellation points as dictated by the modulation scheme, to soft decision bits or LLR (log-likelihood ratio) values.

The Petri Net scheme correspondent to the SDM is represented in Figure 12. The hardware resource that implements the function is pipelined, therefore it is modelled as explained previously, by distinguish the time required for the stage (that is equal to one clock cycle in this case) and the time required for the computing.

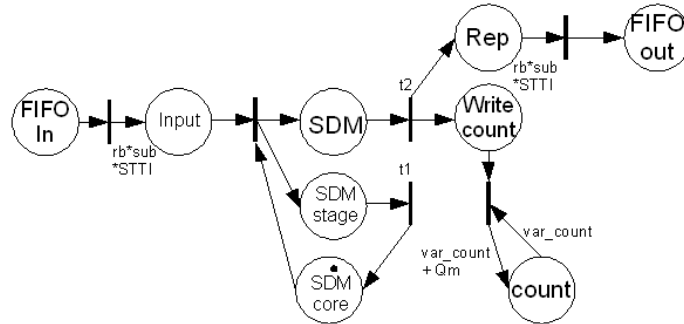

Fig. 12. Petri Net structure for the Symbol demapper

The module operates with the granularity of a “complex data sample”, that for each user is proportional to the number of resource blocks (in particular it is equal to the number of resource blocks multiplied by the subcarriers *sub* and symbols per TTI *STTI*). The first transition therefore generates the tokens corresponding to the data samples that will be processed by the engine and put them in the input place. To generate the next software task the processing of all the tokens must be terminated, therefore a place representing a repository is used to activate the next software task when the processing is finished. Some extra checks, that for simplicity are not shown in the Figure, are used to guarantee the correct execution order.

Each sample generates a number of soft bits dependent on the modulation scheme (represented by parameter Q_m in the Figure). For each processed sample, the total number of bits generated is updated, by the use of the place “count” that contains an integer value token. The token is withdrawn and put back with its value updated. This is an alternative to the use of many tokens representing the soft bits, that has been chosen in order to increase the model efficiency. Indeed, for the simulation engine, updating the value of a single token is simpler and quicker than maintaining all the information related to a large number of tokens.

Rate De-Matcher

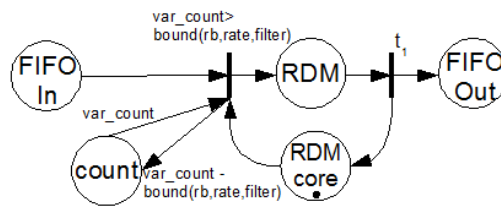

Fig. 13. Petri Net structure for the rate de-matcher

The rate de-matcher is activated when a request is ready and the symbol demapper has produced enough bits to start the computation. Therefore, we use a condition on

the module input transition that checks if enough bits are available to start the computation. In this case, the transition fires, with the effect that the number of bits is updated and the computation is started. Figure 13 represents the corresponding net.

CTC (Turbo decoder)

The Turbo model has two input buffers, a core execution module and two output buffers. The functioning is divided into 3 stages: loading, executing and unloading. The corresponding PN is represented in Figure 14. The load operation can start when the input port and a input buffer are available. After that, data are ready to be processed by the core. The processing can start if an output buffer is available (to write the produced data) and the execution core is free. At the end of the execution the input buffer is freed and can be used to load new data. Finally data are unloaded when an output port is available and at the end the output buffer is freed. The transitions timing depends on the parameters affecting the system, and on the configuration of the hardware module.

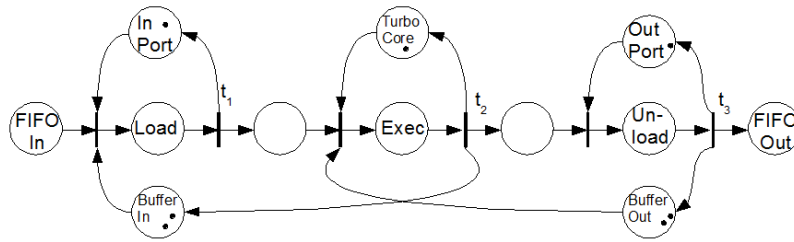

Fig. 14. Petri Net structure of the Turbo block

Experimental results

In order to collect information about the application performance, the Petri Net model has been simulated using the CPNtool developed by CPN Group of University of Aarhus in Denmark [19]. The tool allows to describe a TCPN, to automate the simulations and to collect statistics. The results obtained from the model have been compared with accurate simulation results obtained by implementing the application on the reference architecture. These results have been collected by integrating the ISS simulator of the Altera multithreaded CPU with software models of the hardware event modules annotated with high level latencies.

In the following, we investigate different transmission scenarios. Each configuration specifies the number of users, and for each user the assigned number of Resource Blocks (RB), the coding rate (CR) and the modulation scheme. The number of users and resource blocks affect the number of blocks processed by the system. The coding rate and the modulation scheme affect the block dimension. In particular the block

dimension increases with a lower coding rate and a modulation scheme with more constellation points.

The considered scenarios are the following:

1. 110 users, with 1 resource block each, coding rate $5/6$, modulation 64 QAM.
2. 5 users with different spectrum allocations: (RB=10,CR= $5/6$), (RB=36,CR= $1/9$), (RB=20,CR= $1/9$), (RB=4,CR= $3/4$), (RB=40, CR= $1/4$), modulation 64 QAM.
3. 2 users, with different spectrum allocations (RB=100,CR= $5/6$), (RB=10,CR= $5/6$), modulation 64 QAM.
4. 50 users with 1 resource block each, coding rate $1/3$, modulation QPSK.
5. 18 users with 6 resource blocks each, coding rate $2/3$, modulation 16 QAM.

Figure 15 shows the data chunks output times obtained for in the five scenarios, for both the simulations. The dimension and number of the data chunks elaborated for each user are computed according to the LTE specification [18].

The performance evaluation shows that the system composed of the shaded blocks represented in Figure 6 is able to support the strict timing performance (1ms for 110 resource blocks) in all the tested configurations. The use of the Petri Net model allows to obtain such evaluation in early stages of the system development, without requiring an actual hardware/software integration.

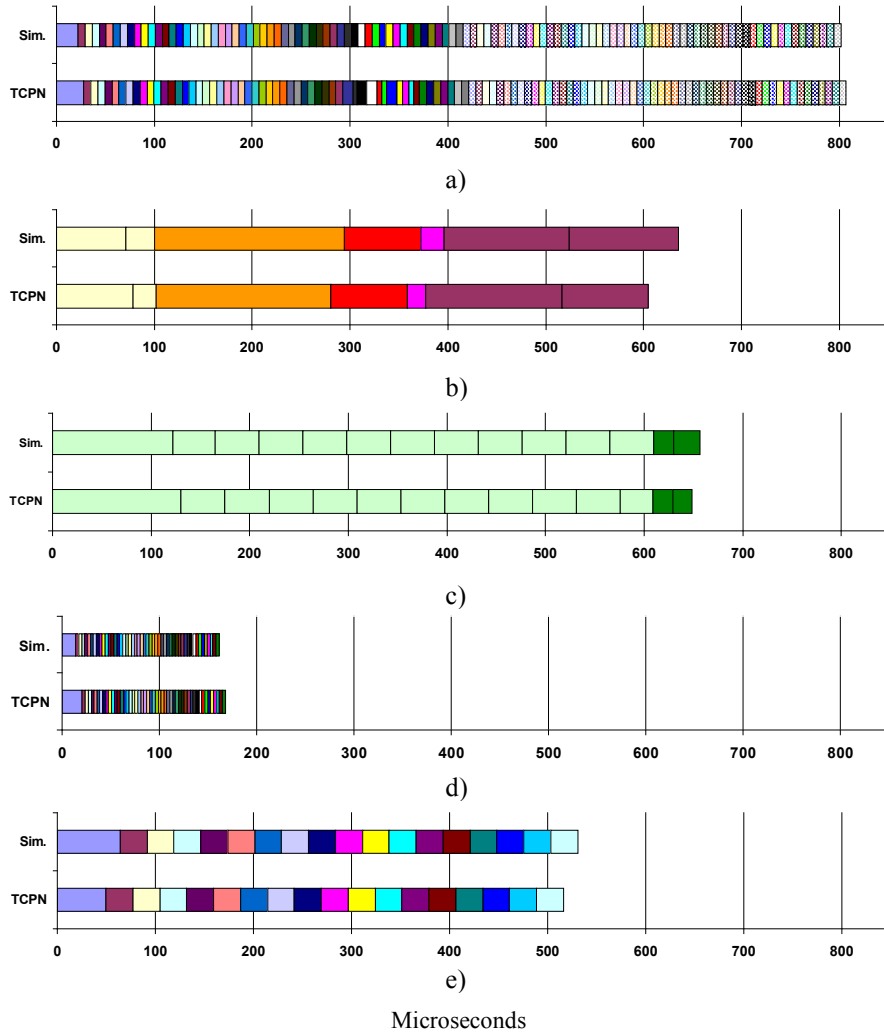

Fig. 15. Comparison between the system output times obtained through TCPN and the real system simulation for different scenarios. Each colour represents a user.

The comparison with the results obtained by combining the hardware and software modules shows that the TCPN model can provide a good accuracy. Figure 16 represents the errors in the arrival times for all the data chunks in all the five scenarios. The difference between the arrival times obtained using the Petri Net and the ones obtained simulating the system are always inferior to 35 microseconds, as shown by the left Y-axis in the graph. Normalizing the values with the greatest arrival time (first scenario) we obtain errors inferior to 5%, as shown by the right Y-axis in the graph. Considering for each scenario a normalization to the greatest arrival time of that scenario, we still obtain errors inferior to 5%.

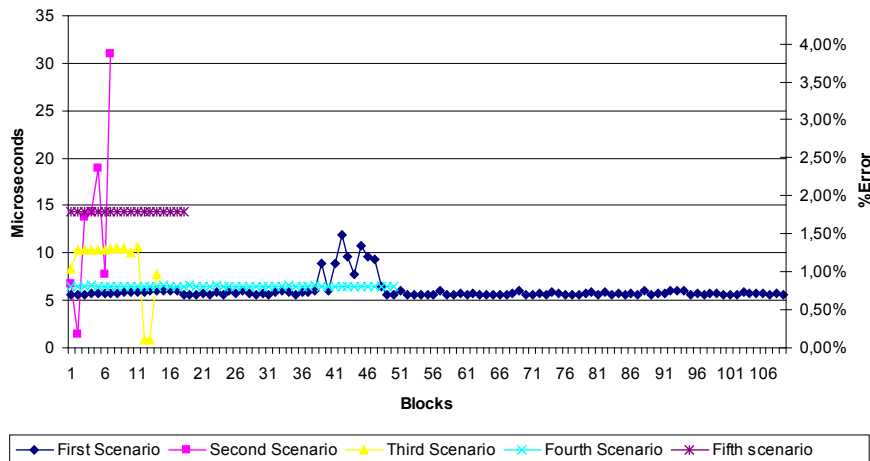

Fig. 16. Absolute and percentage errors of the blocks arrival times in each scenario

Conclusion

One of the main problems, when designing a DSP application, is the meeting of strict timing constraints; however, the verification of the system can usually be performed very late in design phase. This paper proposes the use of Timed Coloured Petri Net for the early evaluation of the system Performance of Hardware/Software DSP applications. We show how to model an application by generating a TCPN that considers the functions and the resources composing the system. The modelling of the 3GPP LTE application has been considered as case study. The experimental results are quite accurate when compared with hardware/software simulations and, as a substantial advantage, can be generated in early stages of the design, when modifications and improvements of the system are still possible. The proposed approach reduces the risk of highly expensive re-spins for the modification of the final system and provides room for the exploration of the solution space.

References

- 1 D. D. Gajski, IP-based methodology, Proc. of 36th DAC, 1999.
- 2 C. Haubelt, J. Falk, J. Keinert, T. Schlichter, M. Streubühr, A. Deyhle, A. Hadert, J. Teich, A SystemC-based design methodology for digital signal processing systems, EURASIP J. Embedded Syst., 2007, n. 1.
- 3 K. Ueda, K. Sakanushi, Y. Takeuchi, M. Imai Architecture-level Performance Estimation for IP-based Embedded Systems, DATE 2004.

- 4 A. Papoulis, Probability, Random Variables, and Stochastic Processes, McGraw-Hill, pp. 515-553, 1984.
- 5 B. D. Bunday, An Introduction to Queueing Theory, Oxford University Press, 1996.
- 6 W. M. Zubereck, Timed Petri Nets – definitions, properties and applications; Microelectronic and Reliability, pp 627-644, 1991.
- 7 R. Zurawski, M. Zhou, Petri Nets and Industrial Applications: A Tutorial, IEEE Transactions on industrial electronics, Vol. 41, N. 6, 1994.
- 8 A. Yakovlev, L. Gomes, Luciano Lavagno, Hardware Design and Petri Nets, Springer, 2000.
- 9 H. Blume, T. Von Sydow, T. G. Noll, A case Study for the application of Deterministic and Stochastic Petri Nets in SoC communication Domain, Journal of VLSI Signal Processing, 2006.
- 10 J. Zhan, N. Sang, G. Xiong, Formal Co-verification for SoC Design with Colored Petri Net, Lecture Notes in Computer Science, 2005.
- 11 P. Maciel, E. Barros, W. Rosenstiel, A Petri Net Model for Hardware/Software Codesign, Design Automation for Embedded Systems Journal, Springer 1999.
- 12 C. Rust, J. Tacke, C. Böke, Pr/T-Net Based Seamless Design of Embedded Real-Time Systems, ATPN 2001.
- 13 L. Gomes, A. Costa, Petri nets as supporting formalism within Embedded Systems Co-design, Industrial Embedded Systems Symposium, 2006.
- 14 C. A. Petri, Communication with Automatas, PhD Dissertation, University of Bonn, 1962 (in German).
- 15 K. Jensen, Coloured Petri Nets. Basic Concepts, Analysis Methods and Practical Use. Volume 1, Basic Concepts. Monographs in Theoretical Computer Science, Springer-Verlag, 1997.
- 16 M. Bourcerie, J. Y. Morel, Algebraically structured colored Petri nets to model sequential processes. IEEE Transactions on Systems, Man, and Cybernetics 27 (4): 681-6, 1997.
- 17 3GPP TS 36.300 Technical Specification group radio Access Network, E-UTRA, E-UTRAN, Overall Description, Stage 2
- 18 3GPP TS 36.201, 36.211-14
- 19 CPN Tools, Coloured Petri Net Group, University of Aarhus, Denmark, www.daimi.au.dk/CPnets/
- 20 Altera Corporation, www.altera.com
- 21 R2-061402, Concept evaluation of user plane latency in LTE, Ericsson.
- 22 R2-072187, LS on LTE latency analysis, Ericsson.