



PhD Thesis Defense

Radio Access and Core Functionalities in Self-deployable Mobile Networks

Jad Oueis

Supervised by: Razvan Stanica, Fabrice Valois

November 27, 2018

Outline

- **Introduction**
 - Self-deployable mobile networks
- **Setting Up the Radio Access Network**
 - Frequency & power allocation scheme
- **Setting Up the Local Core Network**
 - Local CN functions placement
- **Connecting Users**
 - Network-aware user association policy
- **Conclusion & Perspectives**

Introduction

Classical Cellular Networks

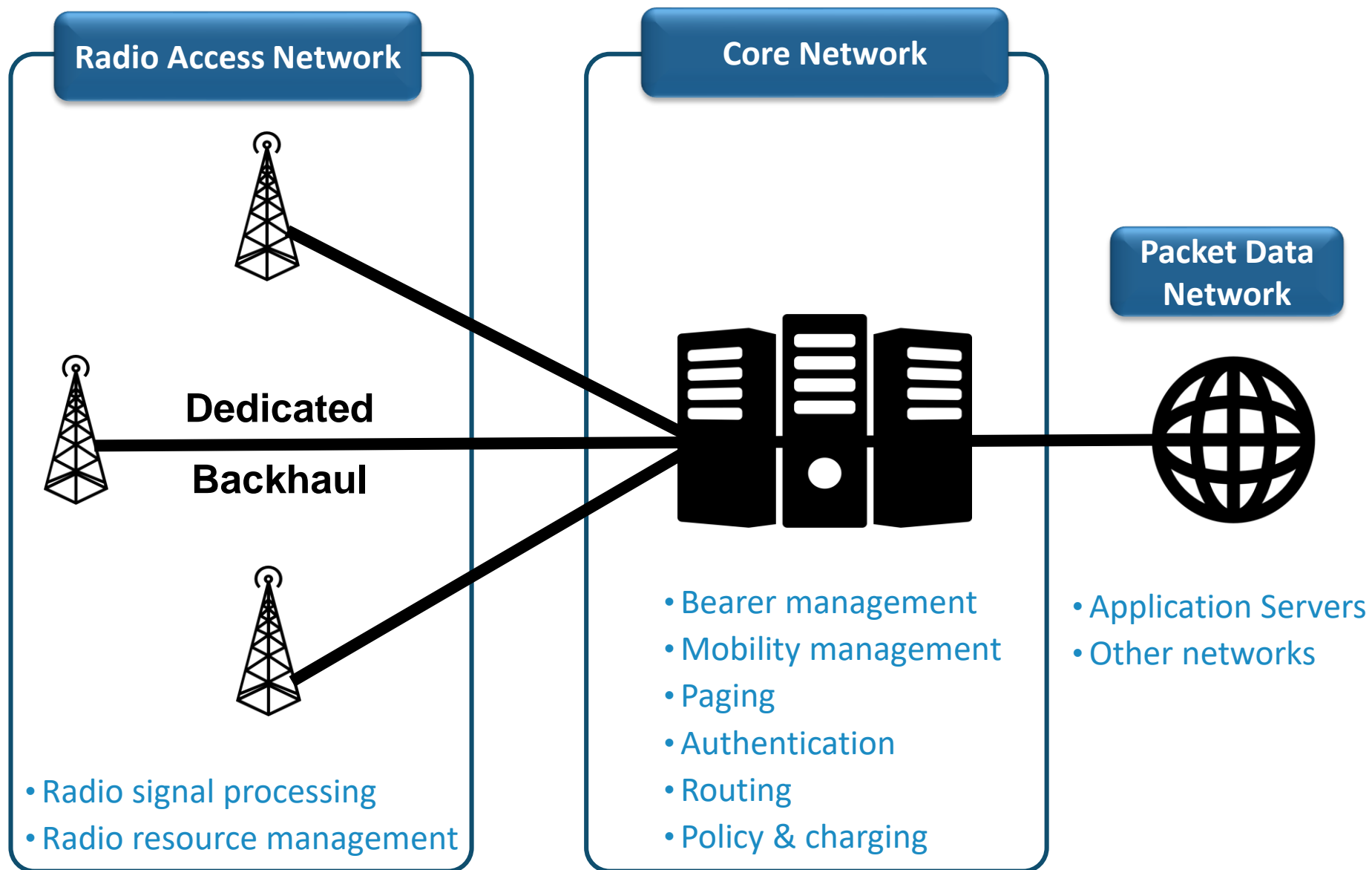

PMR: Professional (Private) Mobile Radio

- Serve a closed group of users belonging to the same organization
- Transportation, military, medical services, public safety

Mission-critical oriented services

- Push-to-talk
- Group communication
- Direct mode operation

Based on legacy standards

- Voice-centric
- Very low data rates
- Gap with commercial mobile networks





- **Bringing PMR to LTE with a high data rate federated network**
 - Dedicated PMR/LTE Networks
 - Mobile virtual network operator on existing LTE infrastructure
 - Legacy PMR networks
 - Rapidly deployable base stations

Rapidly Deployable Base Station

- Lightweight, Easily transportable, rapidly-deployable
 - Radio access network (RAN) functions
 - Core network (CN) functions
 - Application servers (AS)
 - Possible connection to an external packet data network (PDN)

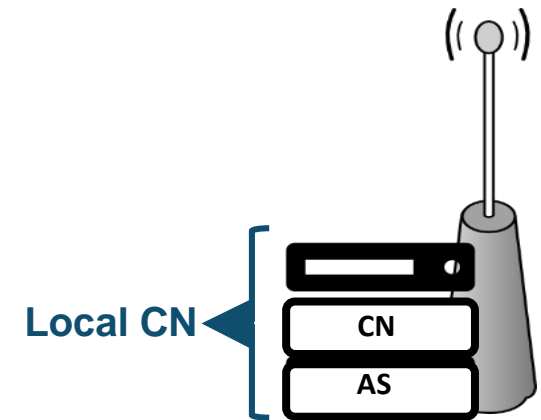

www.air-lynx.com/

Self-deployable Mobile Networks

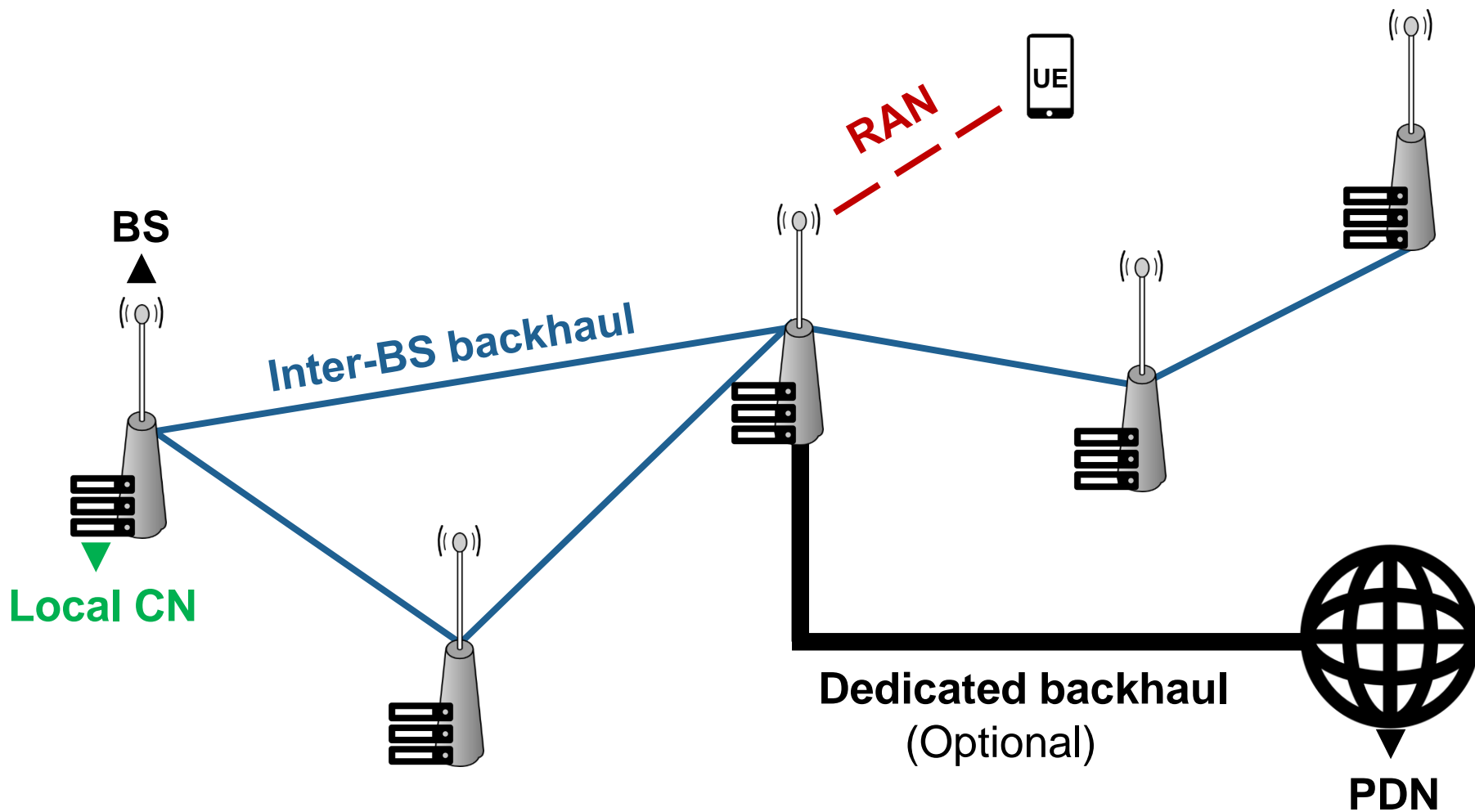

Self-deployable Mobile Networks: Use Cases



Self-deployable Mobile Networks: Use Cases



Self-deployable Mobile Networks

Quick & easy deployment

On demand, anywhere, anytime

Self-organized, self-configured, transportable



Self-deployable Mobile Networks: Properties & Contributions

Setting up the RAN

Frequency & Power Allocation

Setting up the Local CN

Local CN placement

Connecting users

User association policy

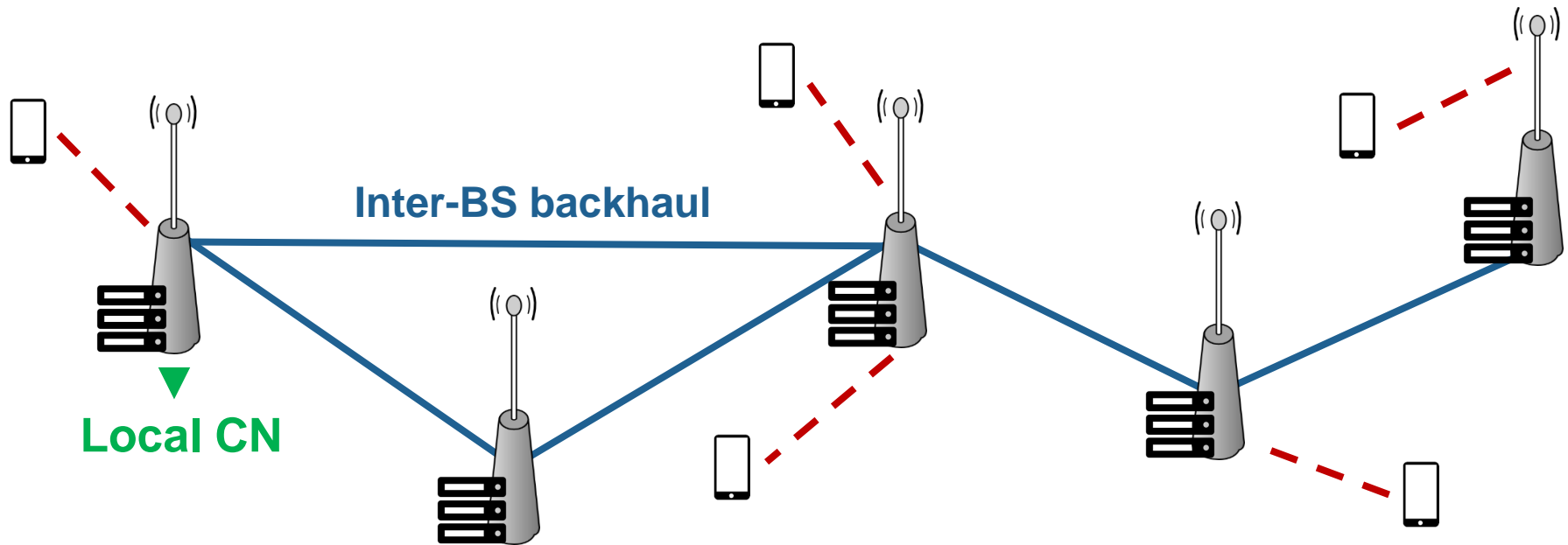

Limited network size

Unplanned topology

Limited backhaul

Local traffic

Guaranteed throughput

Setting up the RAN

Setting up the Local CN

Connecting users

Frequency & Power Allocation Scheme

Frequency & Power Allocation Scheme

- **Self-deployable networks requirements**
 - Suitable for irregular network topologies
 - No a priori knowledge of upcoming number of users & distribution
 - Robust :
 - Performs well despite varying user number & distribution during operation

State of the Art: Static & Dynamic Allocation Schemes

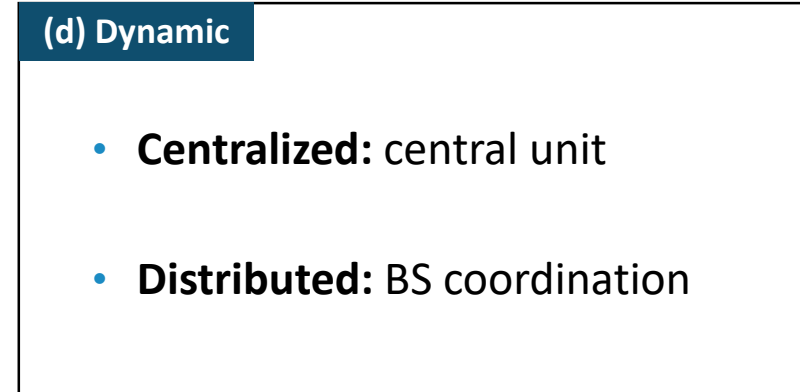
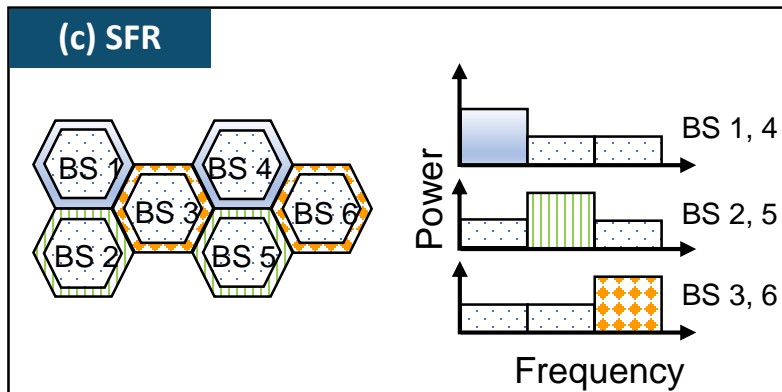
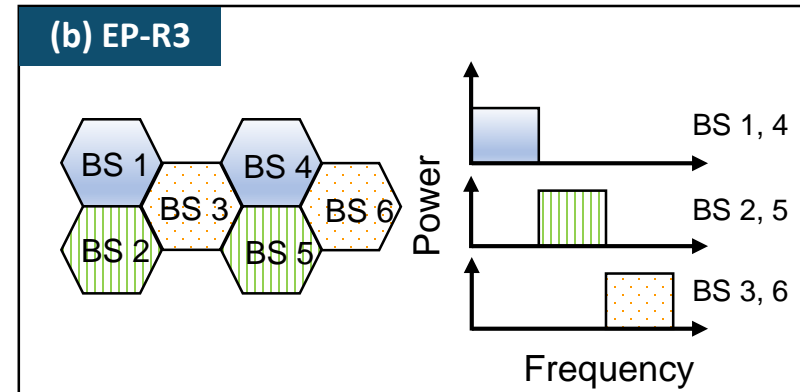
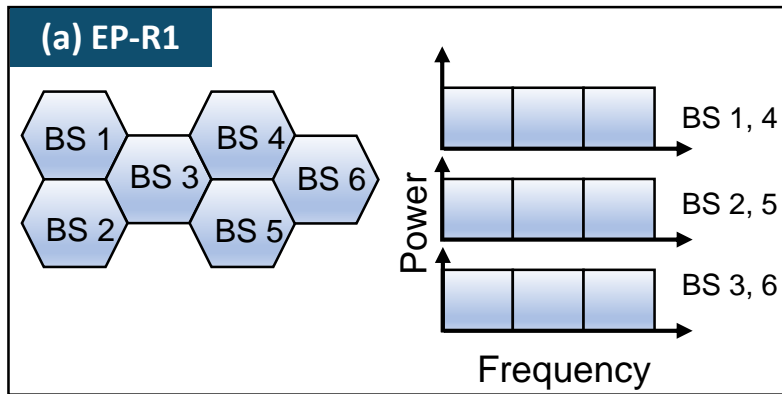

Static:

- Based on hexagonal grid topology
- No adaptation to dynamic changes

Dynamic:

- Communication overhead & latency
- Implementation complexity

Frequency & Power Allocation Scheme

- **Flexible SFR**
 - Spectrum divided into sub-bands (not necessarily 3)
 - BSs can transmit on any sub-band with any power level (not necessarily 2)
- **Power Map** : with which power each BS transmits on each sub-band
- Computed offline, based on geometric programming

System Model

- J : set of base stations
- M orthogonal channels
- Spectrum divided into b sub-bands, \mathcal{S} : set of sub-bands
- Each sub-band $s \in \mathcal{S}$ has $K = M/b$ sub-channels
- **Power Map**: each BS $j \in J$ transmits on the channels of each sub-band s with a power P_j^s
- Maximum transmission power of a BS = P_{BS}

$$\sum_{s \in \mathcal{S}} P_j^s \leq P_{BS}, \forall j \in J$$

$M = 45$ channels

$b = 5$ sub-bands

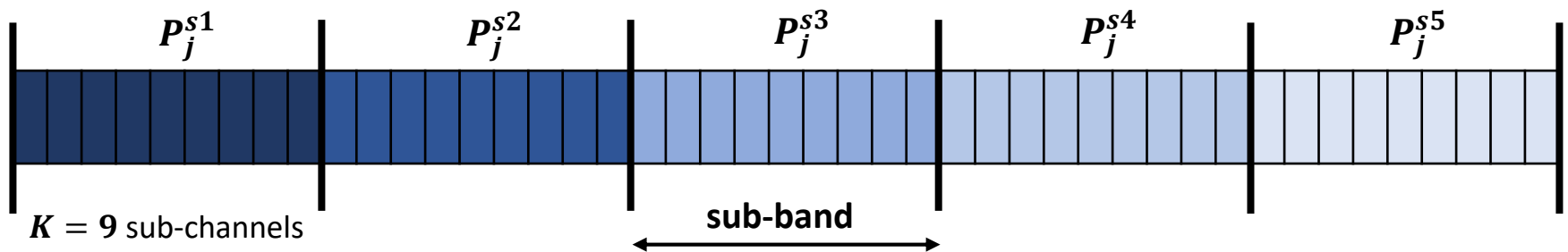

Finding the Power Map

- Known topology
- Unknown upcoming users
- Generate a set of calibration realizations Ω
- For each realization $\omega \in \Omega$:
 - Number of users per realization N_ω
 - Random deployment of N_ω UEs $U(\omega)$
 - Known user association $U_j(\omega)$
- Determine Power Map based on calibration realizations

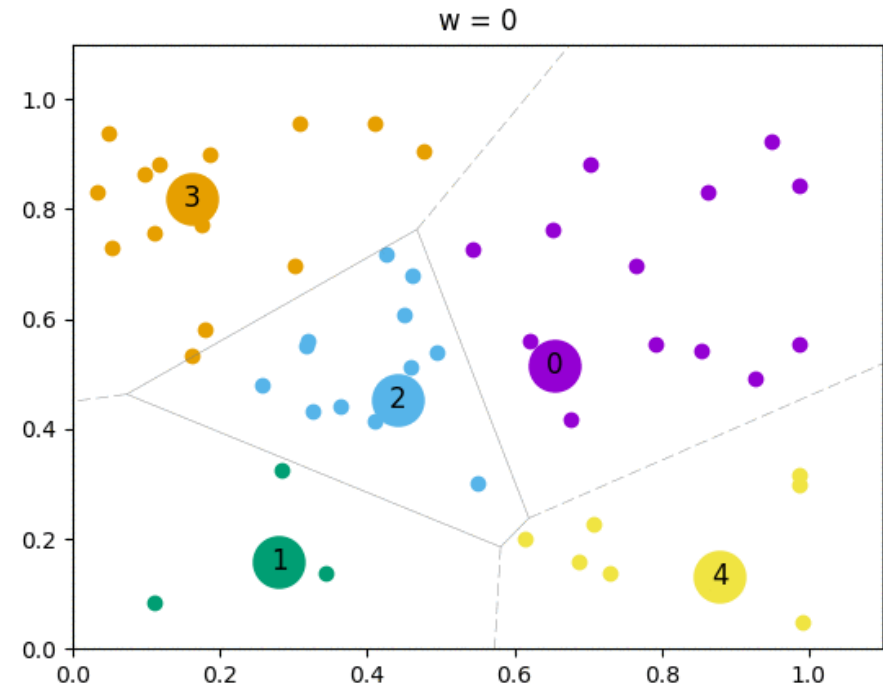

Finding the Power Map: Computation

- Find P_j^s , $\forall j \in J$, $\forall s \in S$
- For each realization $\omega \in \Omega$:
 - Geometric mean (GM) throughput
- Arithmetic mean of all the GM throughputs
- Objective function

$$\Phi = \left(\prod_{u \in \mathcal{U}} \phi_u \right)^{1/|\mathcal{U}|}$$

$$\mathcal{Z} = \frac{\sum_{\omega \in \Omega} \Phi(\omega)}{|\Omega|}$$

$$\max_{P_j^s} \mathcal{Z}$$

Finding the Power Map: Computation

For each realization $\omega \in \Omega$

- Compute for each pair $(u \in U_j(\omega), j)$

- Channel gain $G_{u,j} = 10^{(G^a - E - \Gamma_{u,j} - N(0, sd))/10}$

- Channel gain
 - Antenna gain G^a
 - Equipment losses E
 - Path loss $\Gamma_{u,j} = a + b \cdot \log(d_{u,j})$
 - Shadow fading $N(0, sd)$

Finding the Power Map: Computation

For each realization $\omega \in \Omega$

- Compute for each pair $(u \in U_j(\omega), j)$

- Channel gain $G_{u,j} = 10^{(G^a - E - \Gamma_{u,j} - N(0, sd))/10}$

- SINR

$$\gamma_{u,j}^s = \frac{\frac{P_j^s}{k} G_{u,j}}{N_0 + \sum_{h \in J, h \neq j} \frac{P_h^s}{k} G_{u,h}}$$

- Channel gain
 - Antenna gain G^a
 - Equipment losses E
 - Path loss $\Gamma_{u,j} = a + b \cdot \log(d_{u,j})$
 - Shadow fading $N(0, sd)$
- Noise \mathcal{N}_0
- Power per sub-band P_j^s

Finding the Power Map: Computation

For each realization $\omega \in \Omega$

- Compute for each pair $(u \in U_j(\omega), j)$

- Channel gain $G_{u,j} = 10^{(G^a - E - \Gamma_{u,j} - N(0, sd))/10}$

- SINR

$$\gamma_{u,j}^s = \frac{\frac{P_j^s}{k} G_{u,j}}{N_0 + \sum_{h \in J, h \neq j} \frac{P_h^s}{k} G_{u,h}}$$

- Rate

$$R_{u,j}^s = k \cdot \Psi(\gamma_{u,j}^s)$$

Approximation of the rate step function:

$$R_{u,j}^s = k \cdot \min\left(\nu (\gamma_{u,j}^s)^\Delta, R_{max}\right)$$

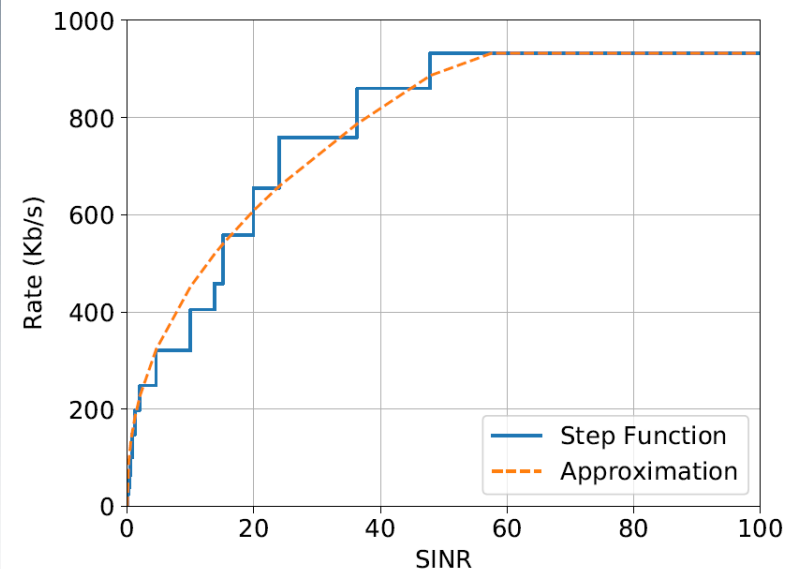

$$R_{max} = 963 \text{ Kb/s}, \nu = 0.168 \text{ and } \Delta = 0.43$$

Finding the Power Map: Computation

For each realization $\omega \in \Omega$

- Compute for each pair $(u \in \mathcal{U}_j(\omega), j)$

- Channel gain $G_{u,j} = 10^{(G^a - E - \Gamma_{u,j} - N(0, sd))/10}$

- SINR
$$\gamma_{u,j}^s = \frac{\frac{P_j^s}{k} G_{u,j}}{N_0 + \sum_{h \in \mathcal{J}, h \neq j} \frac{P_h^s}{k} G_{u,h}}$$

- Rate $R_{u,j}^s = k \cdot \Psi(\gamma_{u,j}^s)$

- Throughput
$$\phi_u = \sum_{s \in \mathcal{S}} \alpha_{u,j}^s \cdot R_{u,j}^s$$

- User scheduling within a sub-band

- $\alpha_{u,j}^s$ = the proportion of time during which the channels in sub-band s are allocated to user u in BS

$$\sum_{u \in \mathcal{U}_j} \alpha_{u,j}^s \leq 1, \forall s \in \mathcal{S}, \forall j \in \mathcal{J}$$

Finding the Power Map: Computation

For each realization $\omega \in \Omega$

- Compute for each pair $(u \in \mathcal{U}_j(\omega), j)$

- Channel gain $G_{u,j} = 10^{(G^a - E - \Gamma_{u,j} - N(0, sd))/10}$

- SINR $\gamma_{u,j}^s = \frac{\frac{P_j^s}{k} G_{u,j}}{N_0 + \sum_{h \in \mathcal{J}, h \neq j} \frac{P_h^s}{k} G_{u,h}}$

- Rate $R_{u,j}^s = k \cdot \Psi(\gamma_{u,j}^s)$

- Throughput $\phi_u = \sum_{s \in \mathcal{S}} \alpha_{u,j}^s \cdot R_{u,j}^s$

- GM throughput $\Phi = \left(\prod_{u \in \mathcal{U}} \phi_u \right)^{1/|\mathcal{U}|}$

Arithmetic mean of all the GM throughputs

$$\mathcal{Z} = \frac{\sum_{\omega \in \Omega} \Phi(\omega)}{|\Omega|}$$

$$\max_{P_j^s, \alpha_{u,j}^s(\omega)} \mathcal{Z}$$

Power Map

Finding the Power Map: Problem Formulation

Complementary GP

Objective (3.17) $\max_{P_j^s, \alpha_{u,j}^s(\omega)} \mathcal{Z}$

Arithmetic mean (3.18)
$$\frac{\mathcal{Z} \cdot |\Omega|}{\sum_{\omega \in \Omega} \left(\prod_{u \in \mathcal{U}(\omega)} \phi_u(\omega) \right)^{\frac{1}{|\mathcal{U}(\omega)|}}} \leq 1$$

SINR (3.19)
$$\frac{\gamma_{u,j}^s(\omega) \cdot k \cdot \mathcal{N}_0 + \gamma_{u,j}^s(\omega) \cdot k \cdot \sum_{h \in \mathcal{J}, h \neq j} P_h^s \cdot G_{u,h}^s}{P_j^s \cdot G_{u,j}^s} \leq 1,$$

$$\forall j \in \mathcal{J}, \forall u \in \mathcal{U}_j(\omega), \forall s \in \mathcal{S}, \forall \omega \in \Omega$$

Rate (3.20)
$$\frac{R_{u,j}^s(\omega)}{k \cdot \nu \cdot \left(\gamma_{u,j}^s(\omega) \right)^\Delta} \leq 1, \forall j \in \mathcal{J}, \forall u \in \mathcal{U}_j(\omega), \forall s \in \mathcal{S}, \forall \omega \in \Omega$$

Rate (3.21)
$$\frac{R_{u,j}^s(\omega)}{k \cdot R_{max}} \leq 1, \forall j \in \mathcal{J}, \forall u \in \mathcal{U}_j(\omega), \forall s \in \mathcal{S}, \forall \omega \in \Omega$$

Throughput (3.22)
$$\frac{\phi_u(\omega)}{\sum_{s \in \mathcal{S}} \alpha_{u,j}^s(\omega) \cdot R_{u,j}^s(\omega)} \leq 1, \forall j \in \mathcal{J}, \forall u \in \mathcal{U}_j(\omega), \forall \omega \in \Omega$$

Power constraint (3.23)
$$\frac{\sum_{s \in \mathcal{S}} P_j^s}{P_{BS}} \leq 1, \forall j \in \mathcal{J}$$

Scheduling constraint (3.24)
$$\sum_{u \in \mathcal{U}_j(\omega)} \alpha_{u,j}^s(\omega) \leq 1, \forall s \in \mathcal{S}, \forall j \in \mathcal{J}, \forall \omega \in \Omega$$

Finding the Power Map: Solving the Problem

- **Geometric Program (GP):**

$$\begin{array}{l} \text{Minimize } g_0(x) \\ \text{Subject to } g_i(x) \leq 1 \\ \quad \quad \quad h_k(x) = 1 \end{array}$$

$$g(x) = \sum_k h_k(x) \quad : \text{Posynomial}$$
$$h_k(x) = d_k x_1^{a_k^{(1)}} x_2^{a_k^{(2)}} \dots x_n^{a_k^{(n)}} \quad : \text{Monomial}$$

- Transformed in a **convex** problem through a **logarithmic transformation** of the variables

- **Complementary GP**

- Contains a constraint of the form: $g_1(x)/g_2(x) \leq 1$



Not a posynomial

- Transformed into a **GP** via iterative algorithm

Finding the Power Map: Solving the Problem

- Non- posynomials constraints are transformed into posynomials
 - Approximate the denominator $g(x)$ with a monomial $\tilde{g}(x)$
 - Find the point x_0 for which $g(x) \approx \tilde{g}(x)$ via iterative algorithm

Algorithm 1 Single condensation method for GP

- 1: Find an initial feasible point $\mathbf{x}^{(0)}$
 - 2: At the i^{th} iteration, approximate $g(x)$ with $\tilde{g}(x)$ around the point $\mathbf{x}^{(i-1)}$
 - 3: Form the i^{th} approximated GP problem using the approximated $\tilde{g}(x)$
 - 4: Solve the i^{th} approximated GP problem (by turning it into a convex problem through a logarithmic change of variables) to obtain $\mathbf{x}^{(i)}$.
 - 5: **if** $\|\mathbf{x}^{(i)} - \mathbf{x}^{(i-1)}\| < \epsilon$ **then**
 - 6: End
 - 7: **else**
 - 8: Go to step 2
 - 9: **end if**
-

Finding the Power Map: Numerical Example

- $\mathbf{b} = 5$ sub-bands, $|\Omega| = 10$ calibration realizations, $N_{\omega} = 100$ users
- Using open source solver “Bonmin”

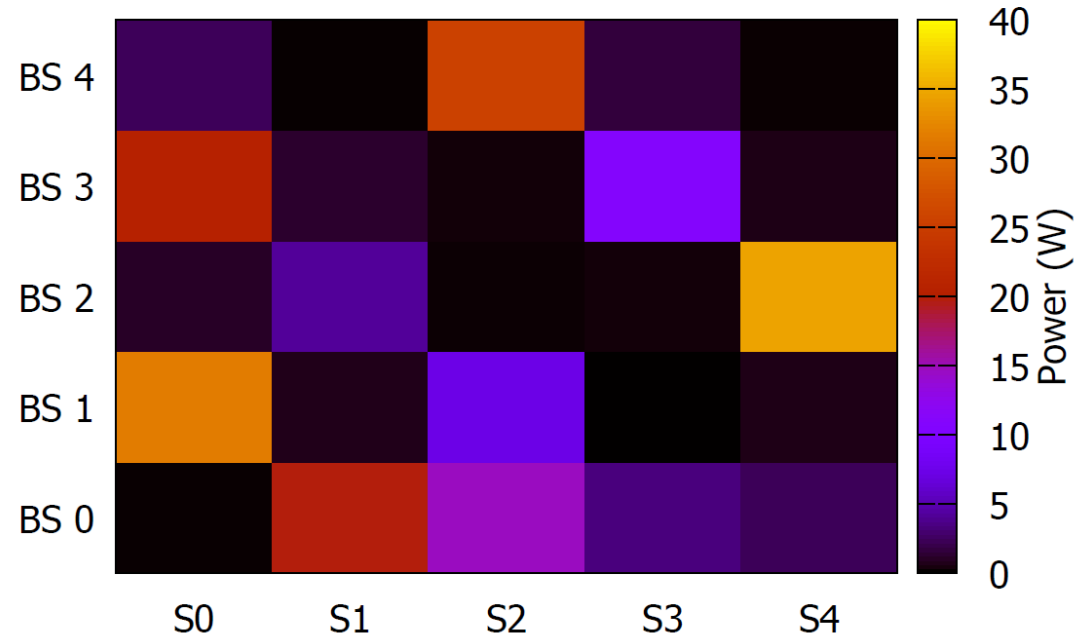
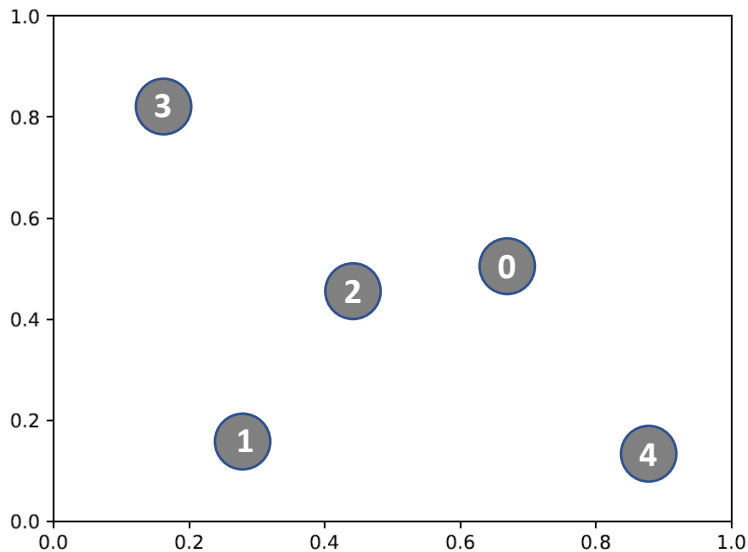

Solving time = 97 min

- At least 1 sub-band/BS with higher power
- All other sub-bands with lower powers
- Few channels with high power to users farthest from BS
- More channels with lower power to users closest to the BS

Performance Evaluation

- Testing of the obtained power map on snapshots with $N_{\pi} = 100$ users each

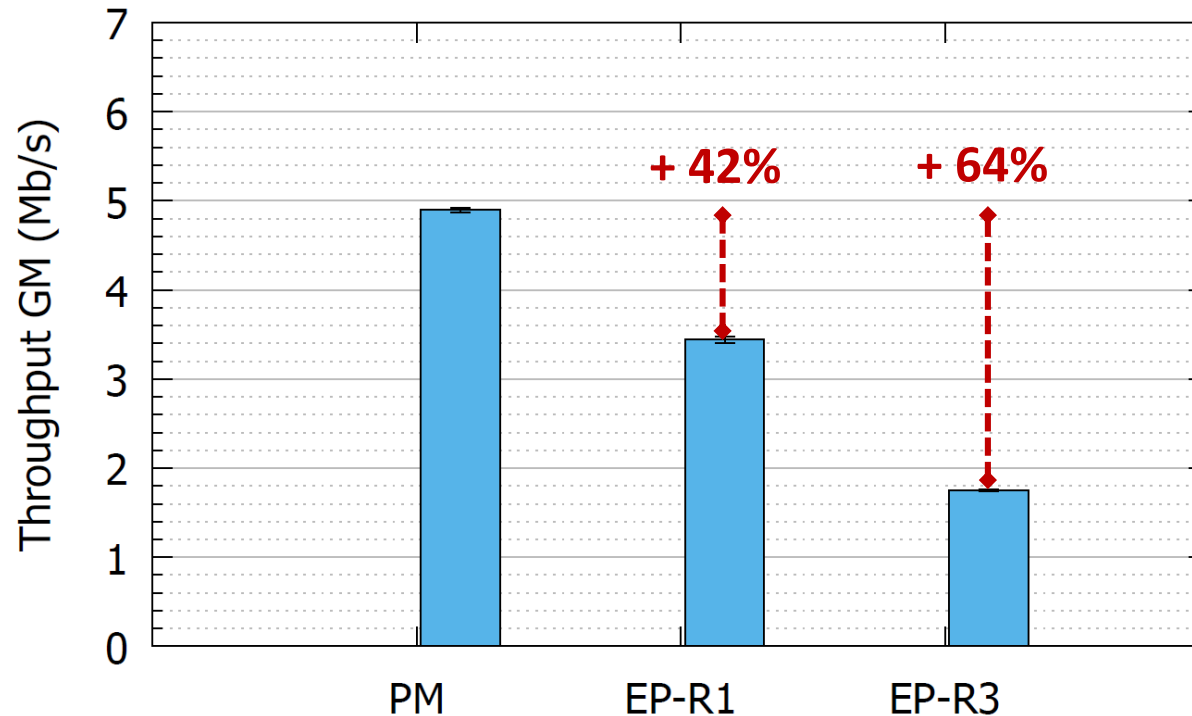

- Gain is due to an increase in all the users' throughputs

Performance Evaluation

- Number of users in each calibration realization N_ω
- Number of users in the test realization N_π on which PM is tested

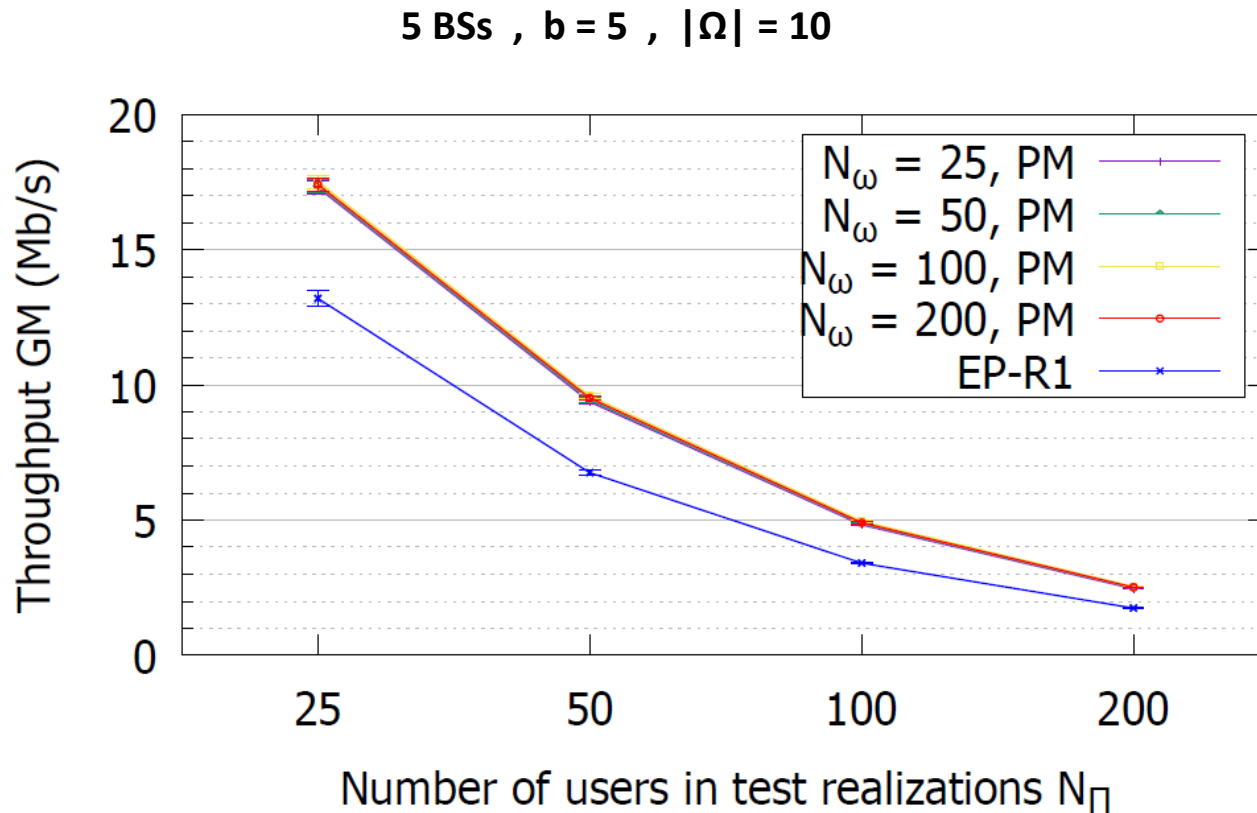

Performance Evaluation

- Number of sub-bands b

5 BSs , $|\Omega| = 10$, $N_\omega = 100$, $N_\pi = 100$

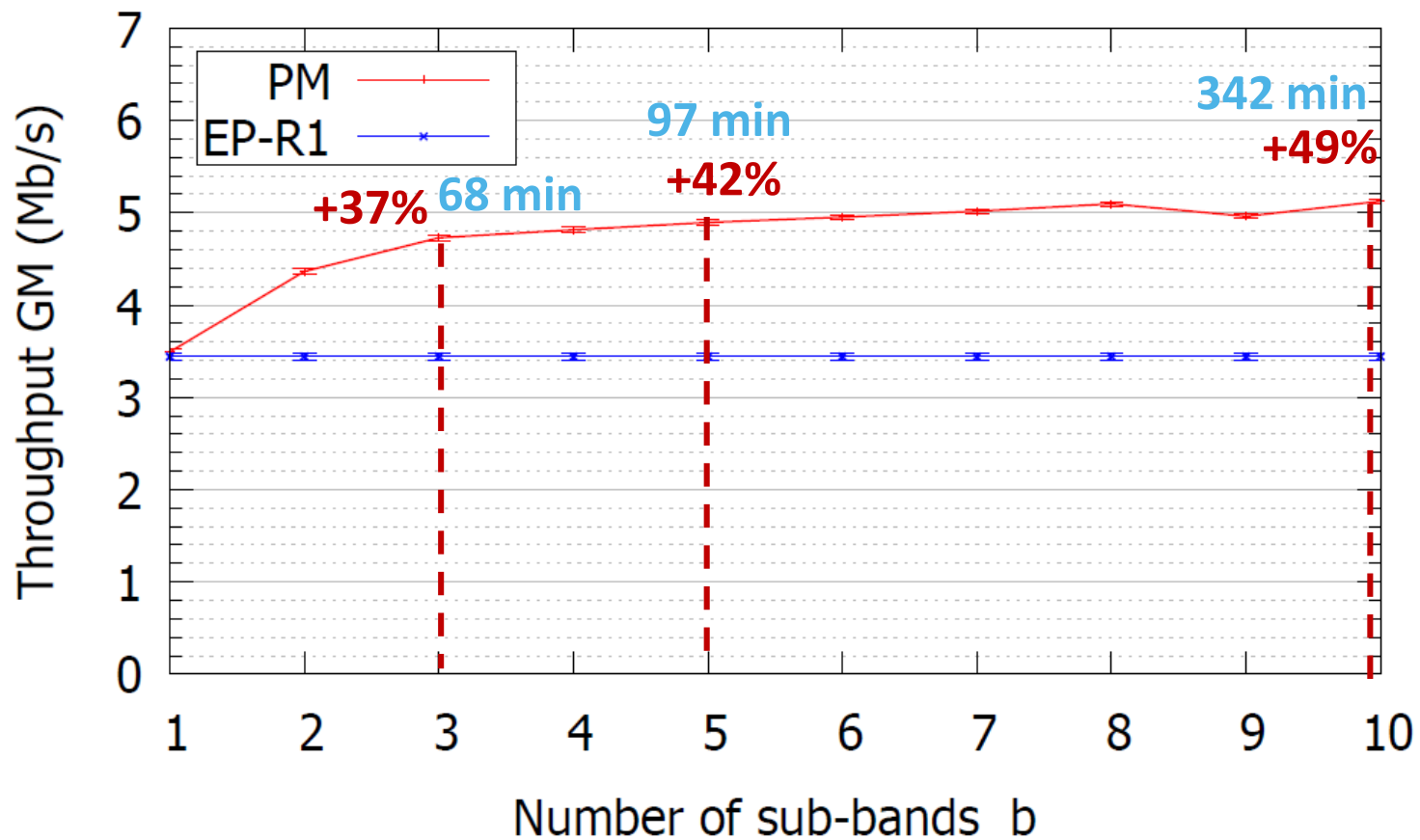

Setting up the RAN

Setting up the Local CN

Connecting users

Local CN Functions Placement

Local CN Functions Placement

- **Main core network functions**

- MME: session management, authentication, paging, S-GW selection
- S-GW: routing, data buffering, mobility anchor

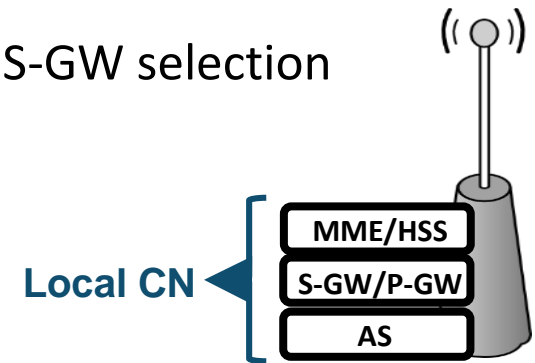

- **Local CN**

- Virtualized set of core network functions co-located with the BSs
- One Local CN per network/ One or multiple instances per function

- **Problem**

- How many instances of each function are needed?
- Where to place each instance?

Local CN Functions Placement

- All traffic routed on inter-BS backhaul
 - Main signaling traffic: **BS** \leftarrow --- **MME** & **MME** \leftarrow --- **S-GW**
 - Data traffic: **BS_u** \longleftrightarrow **S-GW (u)** \longleftrightarrow **S-GW (v)** \longleftrightarrow **BS_v**

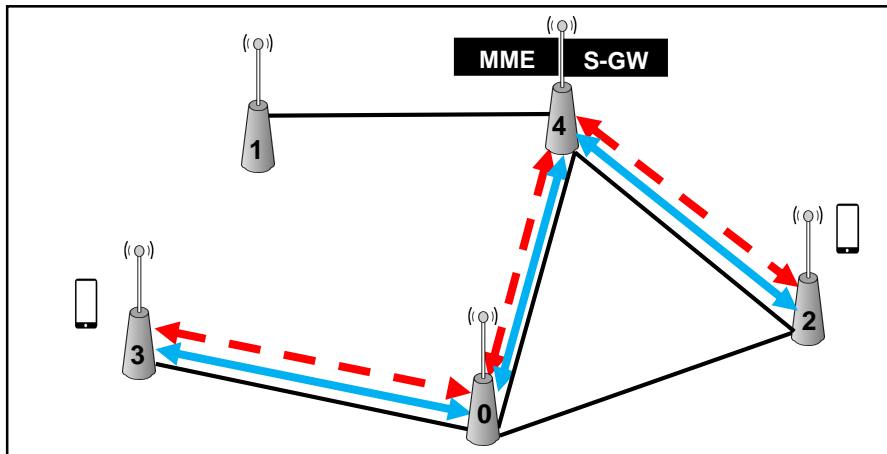

(a) Centralized

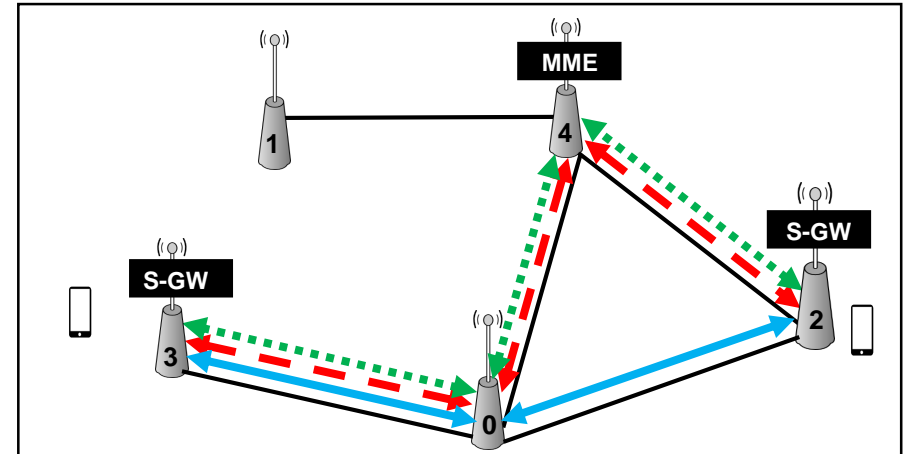

(b) Distributed

Centralized Placement

- All Local CN functions co-located with **1 BS**
- State of the art **centrality metrics**: degree, weighted degree, closeness, betweenness

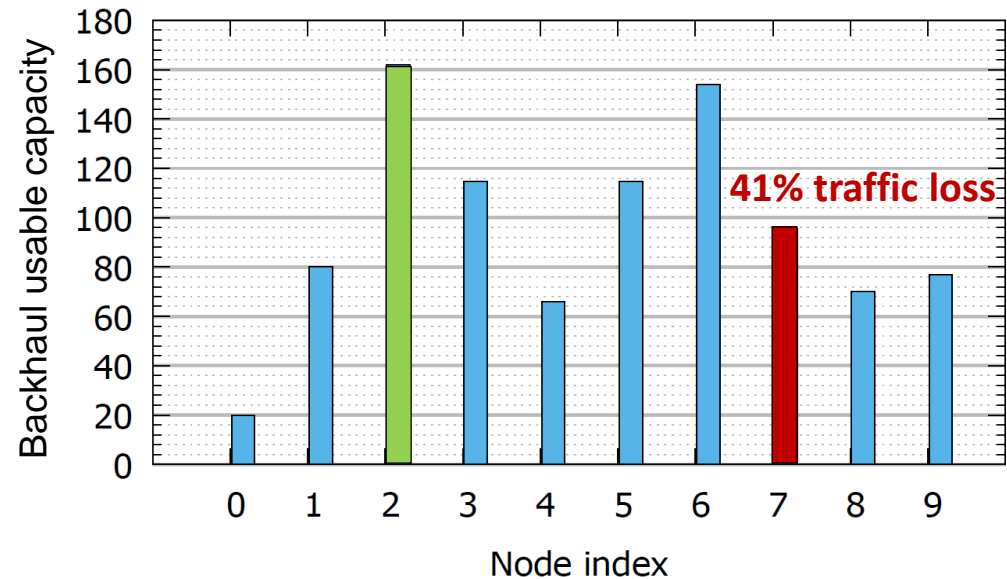
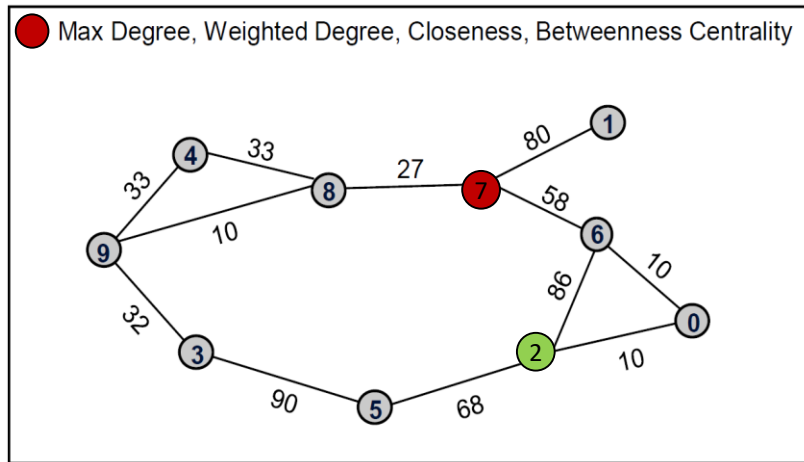

- Proposal of a novel centrality metric: **Flow centrality**
 - Capacity of a node in receiving the total amount of flows, represented by the maximum traffic that can be sent simultaneously by every other node in the network towards this node, under load distribution and backhaul capacity constraints.

Centralized Vs. Distributed Placement

- P_c : Centralized placement
 - MME & S-GW co-located
 - Optimally placed
- P_d : Distributed placement
 - 1 MME optimally placed
 - Each BS co-located with S-GW
- P_o : Optimal placement
 - 1 MME optimally placed
 - S-GW(s) optimally placed

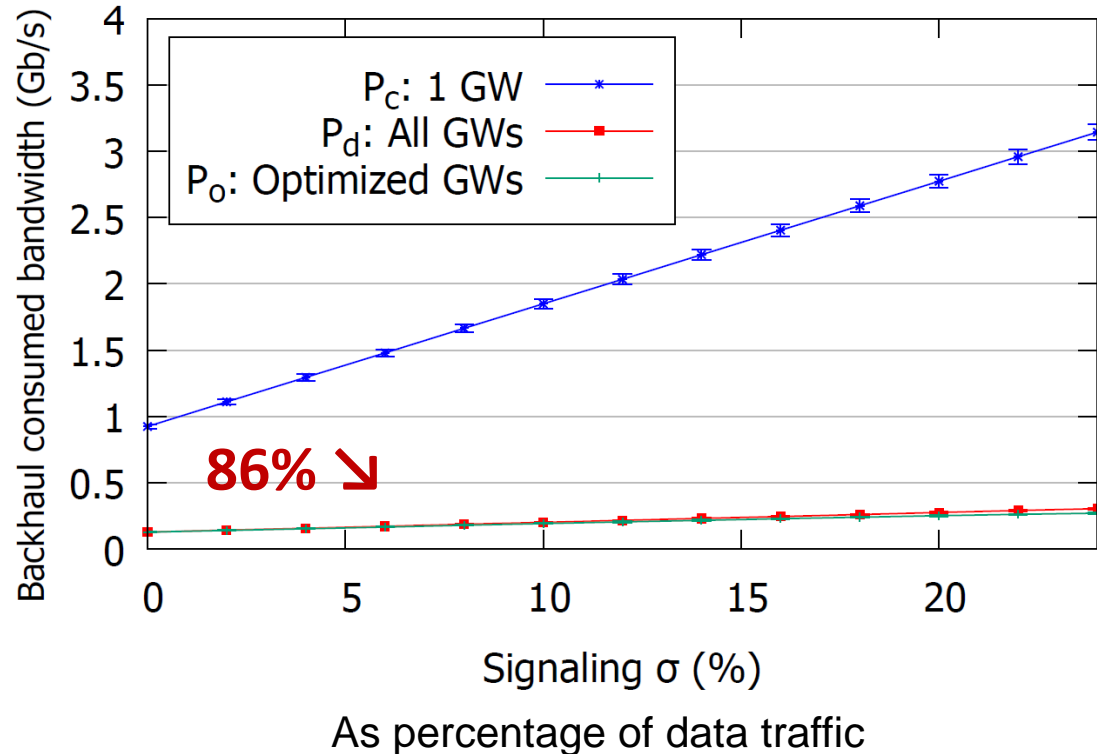

- Solve MILP & compare overall backhaul bandwidth consumption from data and signaling

Setting up the RAN

Setting up the Local CN

Connecting users

Network-Aware User Association Policy

User Association

- **Association policies**

- Mostly based on RAN/Downlink (DL) metric (Best SINR)
- Backhaul (BH) assumed to be over-provisioned
- Uplink (UL) ignored

- **Self-deployable networks requirements**

- BH-aware: network topology & limited backhaul bandwidth
- UL-aware: UL-heavy traffic
- User-aware: guaranteed throughput

Network-Aware User Association Scheme

- **Network-aware user association** scheme
 - Flow admission control
 - The remaining resources on the **DL** of the RAN
 - The remaining resources on the **UL** of the RAN
 - The remaining resources on the **BH** network
 - The requested **throughput**

- **Objectives**
 - Maximize the remaining network resources after a user is associated
 - Reduce the flow blocking probability

Network-Aware User Association Scheme

- 👍 No Consumption on the BH
- 👍 Costs more on the RAN

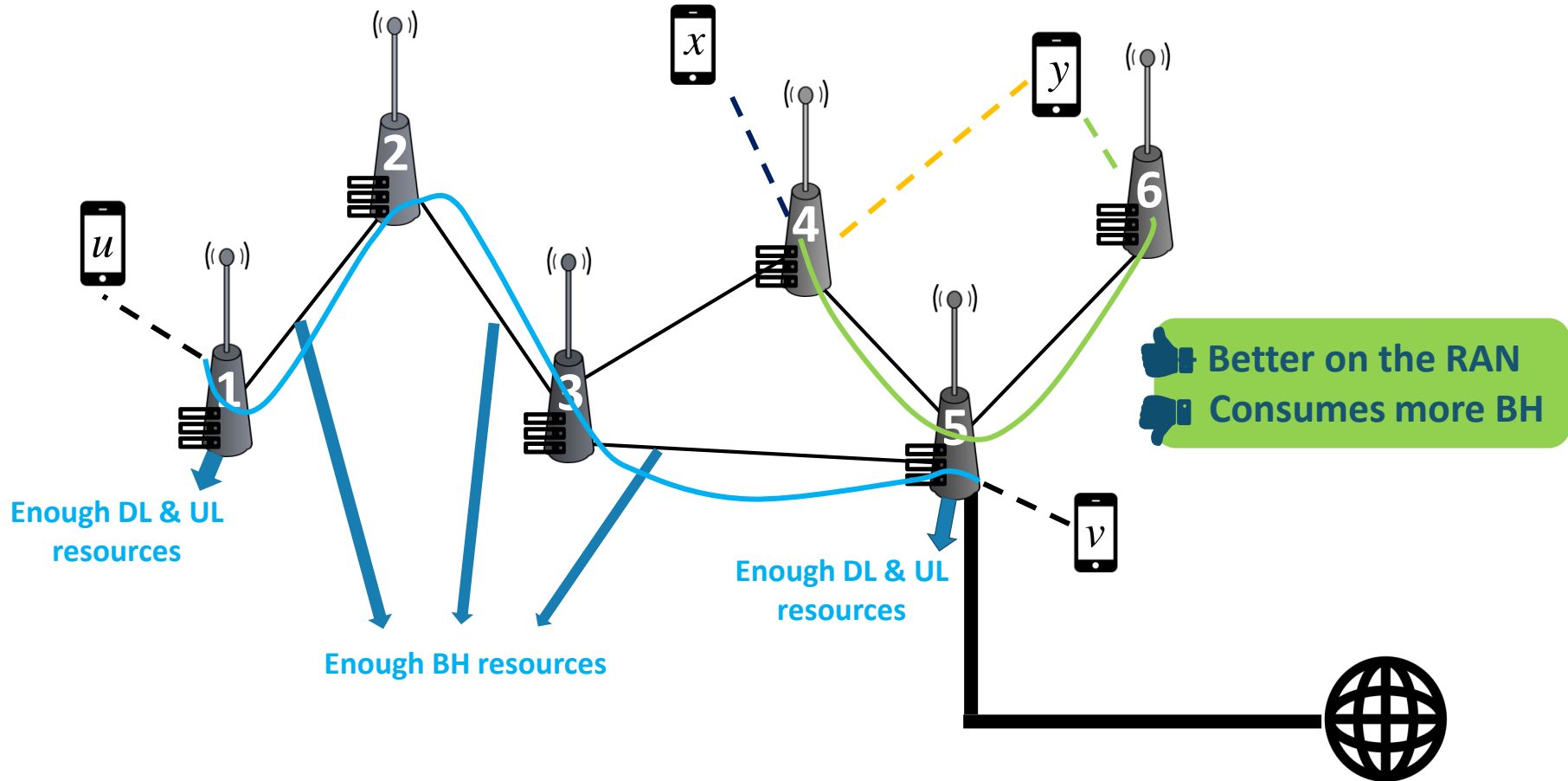

Association Algorithm

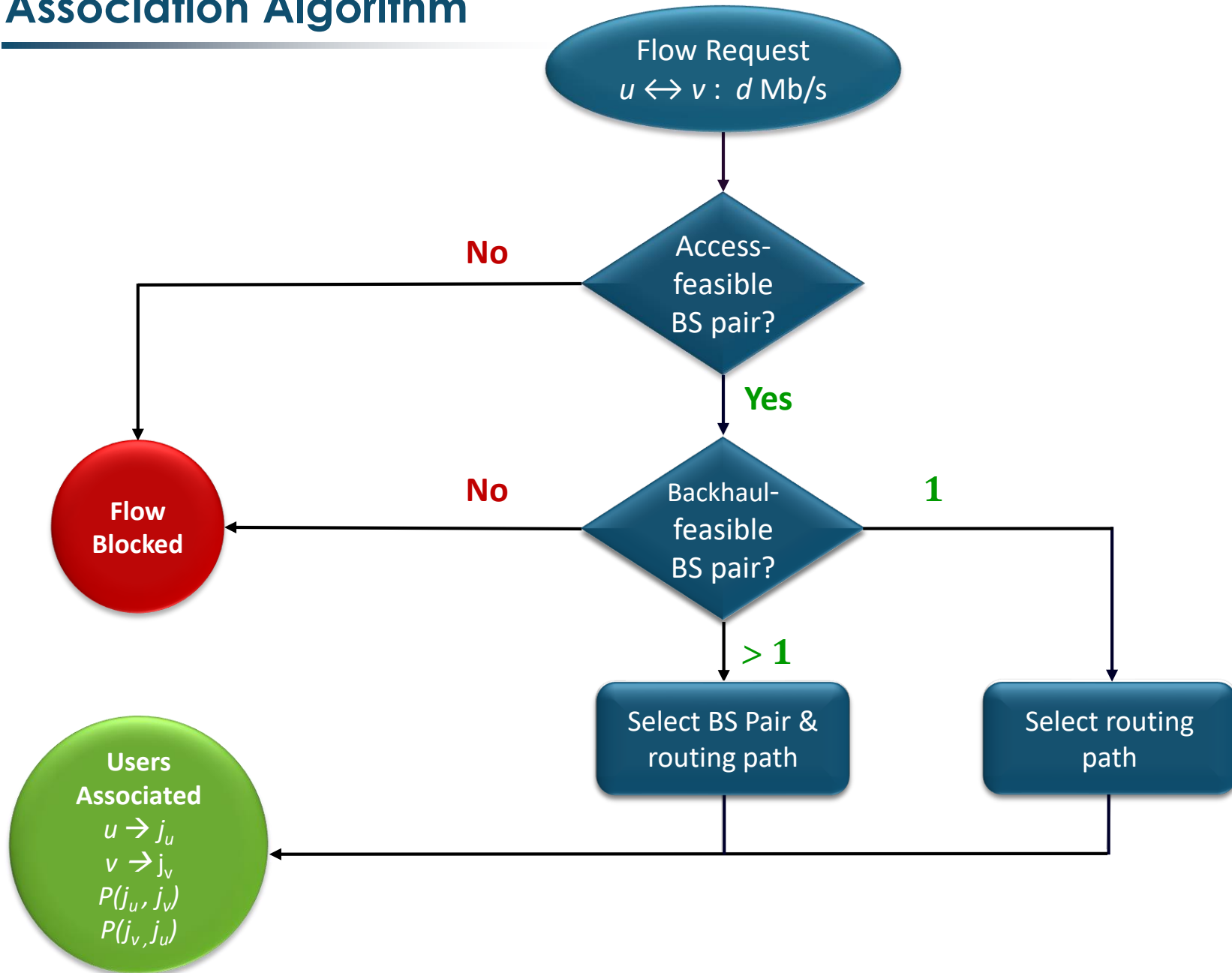

Association & Routing Decision

- Select a pair (i, j) from set of feasible pairs \mathbb{F}
- Select a path $P(i, j)$ and a path $P(j, i)$ from the set of feasible paths $\mathcal{P}_{i,j}$ and $\mathcal{P}_{j,i}$

- **DL** - Metric representing the remaining DL channels if (i, j) was selected

$$L_{i,j}^{DL} \in [0, 1], \forall (i,j) \in \mathbb{F}$$

- **UL** - Metric representing the remaining UL channels if (i, j) was selected

$$L_{i,j}^{UL} \in [0, 1], \forall (i,j) \in \mathbb{F}$$

- **BH** - Metrics representing the remaining BH capacity if $P(i, j)$ and $P(j, i)$ were selected

$$L_{P(i,j)}^{BH} \in [0, 1], \forall P(i,j) \in \mathcal{P}_{i,j}$$

$$L_{P(j,i)}^{BH} \in [0, 1], \forall P(j,i) \in \mathcal{P}_{j,i}$$

- **Association & routing metric:**

$$\max_{\substack{P(i,j) \in \mathcal{P}_{i,j} \\ P(j,i) \in \mathcal{P}_{j,i} \\ (i,j) \in \mathbb{F}}} L_{P(i,j)}^{BH} \cdot L_{P(j,i)}^{BH} \cdot L_{i,j}^{DL} \cdot L_{i,j}^{UL}$$

Performance Evaluation

- **Python simulation**

- UEs distributed in the area
- Flows arrive according to Poisson process between 2 random UEs
 - Average flow arrival rate λ
 - Average flow duration $\mu = 180$ s
- Flow data rate $d = 1$ Mb/s

- **Benchmark:** Best SINR association

- **Evaluation Metric:** Blocking probability

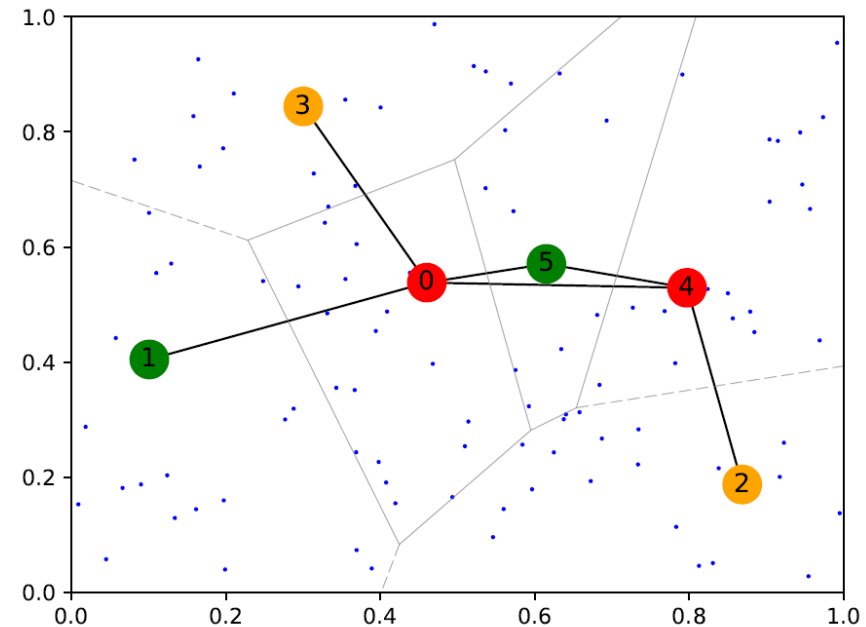

Performance Evaluation

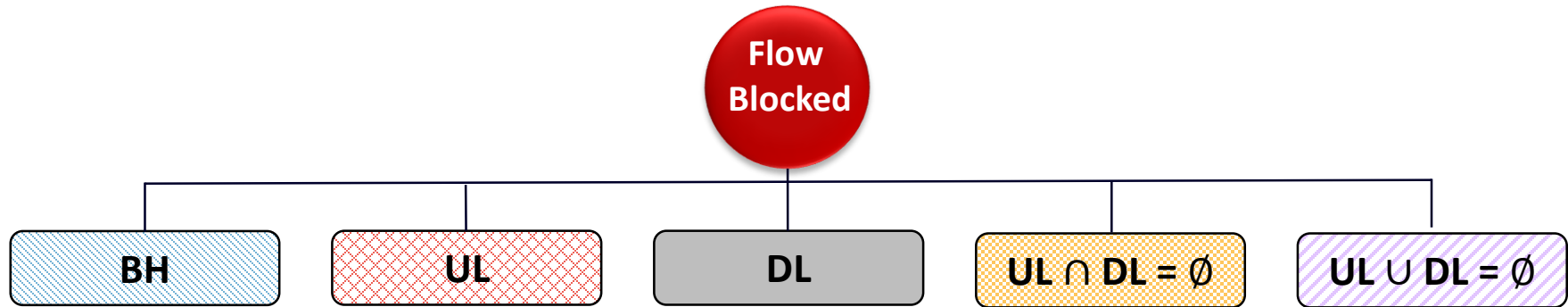

(1) Well-provisioned backhaul: $C_1 = 100 \text{ Mb/s}$

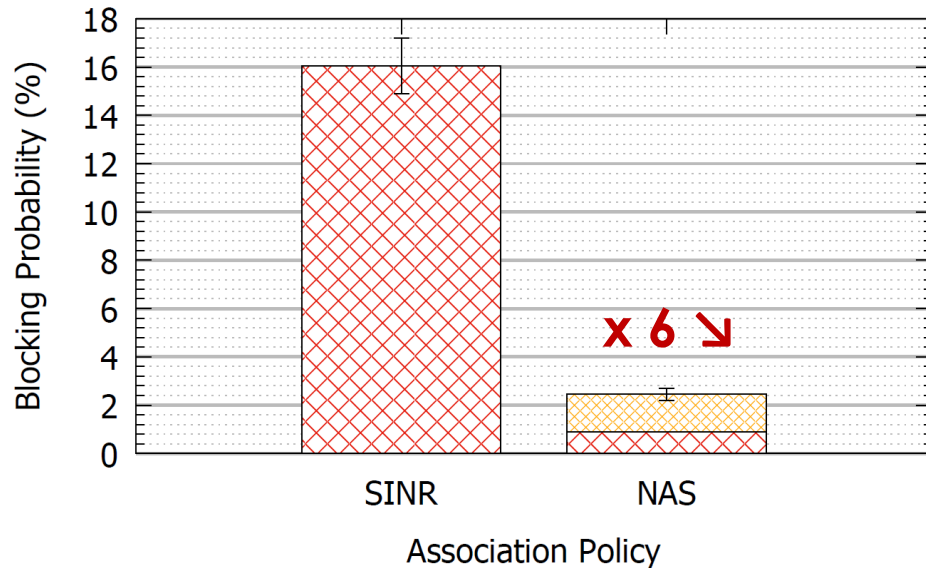

(2) Limited backhaul: $C_1 = 1 \text{ Mb/s}$

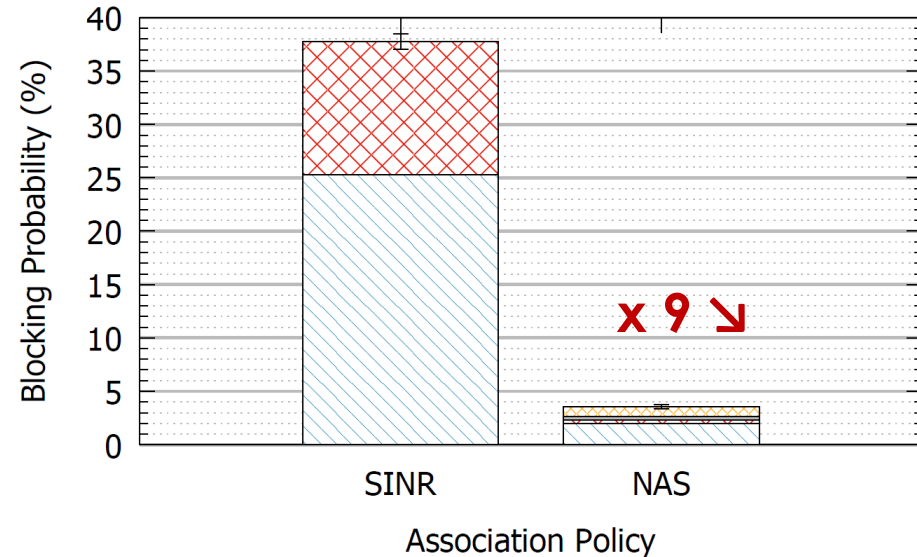

Conclusion & Perspectives

Contributions Summary

Self-deployable Mobile Networks

- Rapidly deployable, easily transportable, small-sized
- Deployed & operated on demand, anywhere, anytime
- Mission critical situations, isolated locations, crowded events

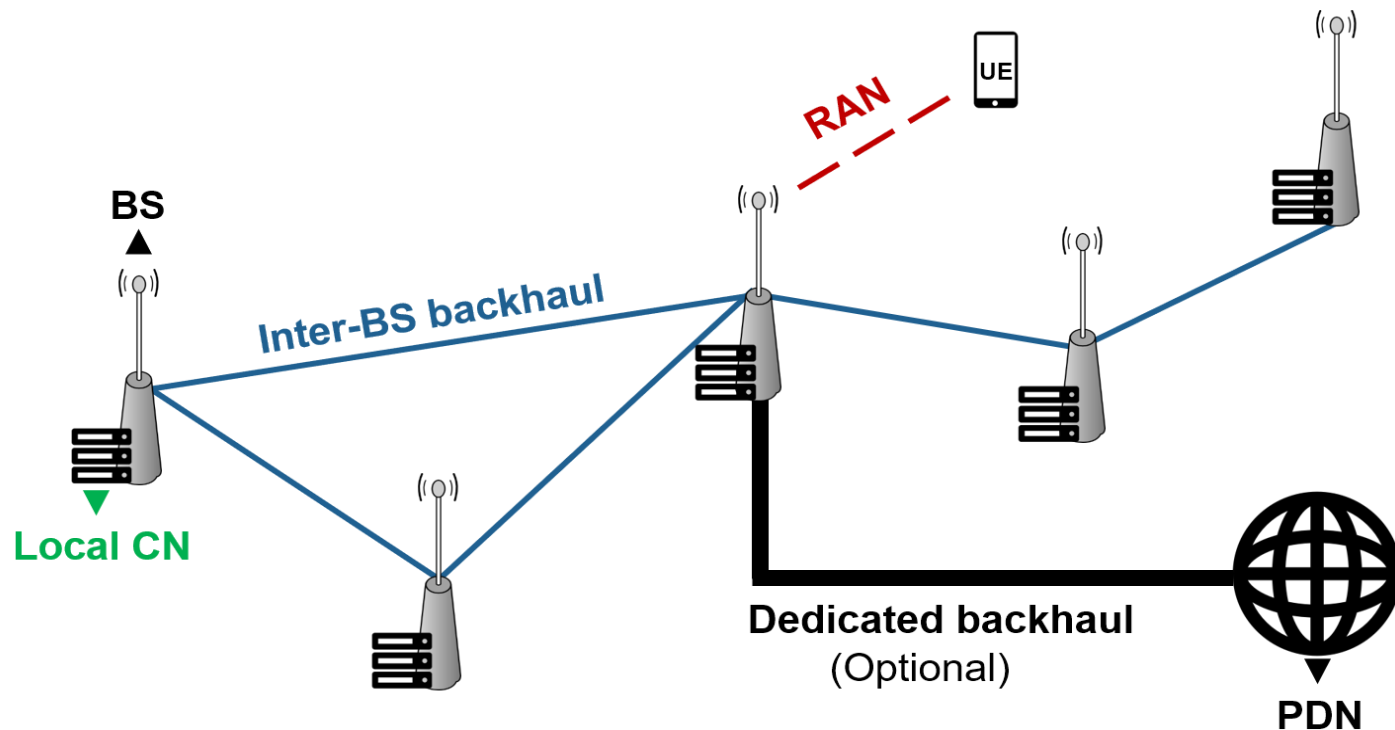

Contributions Summary

Setting up the RAN

- **SFR-based power map:** with which power each BS transmits on each sub-band?
- Computed offline, prior to network operation, based on **geometric programming**
- **Gain > 40%** in user throughput with respect to EP-R1

Setting up the Local CN

- **Local CN functions placement:** with which BS(s) each function is placed?
- Centralized vs. distributed placement, proposal of **flow centrality** metric and **solving MILP**
- Each BS must be co-located with one S-GW; **Gain > 80%** in backhaul capacity

Connecting users

- **Network-aware user association:** with which BS each arriving user must associate?
- **Metric** accounting for guaranteed user throughput, DL, UL and BH resources
- Reduces flow blocking **x9 times** with respect to DL-based policy

Perspectives

- **Real-life deployment**

- Platforms: aerial (*drones, balloons*), terrestrial (*vehicles, robots, humans*)
- Protocols: RAN, Backhaul, CN

- **BSs mobility:** *convoys, BSs in backpacks, drone networks*

- Two-sided mobility management
- Topology changes
- Maintaining inter-BS backhaul & network connectivity
- Network reconfiguration

- **6G & Beyond**

- Flexible cellular networks: transportable, virtualized, autonomous, on-demand
- Integrated access & backhaul
- Single stratum

Acknowledgements

- **Thales Communications & Security** - Paris
 - Vania Conan
 - Damien Lavaux
- **University of Waterloo** - Canada
 - Catherine Rosenberg
- Members of the Jury

THALES



The End.

jad.oueis@insa-lyon.fr

<http://perso.citi.insa-lyon.fr/joueis/>