



HAL
open science

Metamodels and Feature Models: Complementary Approaches to Formalize Product Comparison Matrices

Guillaume Bécan

► **To cite this version:**

Guillaume Bécan. Metamodels and Feature Models: Complementary Approaches to Formalize Product Comparison Matrices. Software Engineering [cs.SE]. Université Rennes 1, 2016. English. NNT : . tel-01416129v1

HAL Id: tel-01416129

<https://inria.hal.science/tel-01416129v1>

Submitted on 14 Dec 2016 (v1), last revised 29 May 2017 (v2)

HAL is a multi-disciplinary open access archive for the deposit and dissemination of scientific research documents, whether they are published or not. The documents may come from teaching and research institutions in France or abroad, or from public or private research centers.

L'archive ouverte pluridisciplinaire **HAL**, est destinée au dépôt et à la diffusion de documents scientifiques de niveau recherche, publiés ou non, émanant des établissements d'enseignement et de recherche français ou étrangers, des laboratoires publics ou privés.

THÈSE / UNIVERSITÉ DE RENNES 1
sous le sceau de l'Université Bretagne Loire

pour le grade de
DOCTEUR DE L'UNIVERSITÉ DE RENNES 1

Mention : informatique

École doctorale MATISSE

présentée par

Guillaume Bécane

préparée à l'unité de recherche IRISA (UMR 6074)
Institut de Recherche en Informatique et Systèmes Aléatoires
ISTIC

Metamodels and
Feature Models:
Complementary
Approaches to
Formalize Product
Comparison Matrices

Thèse soutenue à Rennes
le 23 septembre 2016

devant le jury composé de :

Laurence DUCHIEN

Professeur, Université de Lille 1 / rapporteur

Andrzej WAŚOWSKI

Associate Professor, IT University / rapporteur

Felienne HERMANS

Assistant Professor, Delft University of Technology
/ examinateur

Olivier RIDOUX

Professeur, Université de Rennes 1 / examinateur

Mathieu ACHER

Maître de conférence, Université de Rennes 1 /
examineur

Benoit BAUDRY

Chargé de recherche, Inria / directeur de thèse

Résumé en français

J'ai testé toutes les langues, j'ai une faiblesse pour le français. C'est une langue merveilleuse.

Le Mérovingien

Contexte

À l'horizon 2020, on estime la quantité de données utiles dans le monde à 16 zettaoctets [55]. La plupart de cette information n'est pas structurée et est disponible dans divers formats (p. ex. tableurs, JSON, XML, texte). Elle est souvent créée par de nombreux contributeurs sans qu'ils utilisent de standards ou suivent de règles. De nombreux exemples existent sur le web tels que les wikis (p. ex. Wikipedia), les fichiers vidéos et audios ou les interfaces de programmation des services web [53, 55].

Toutes ces données non structurées complexifient l'ingénierie de logiciels pouvant traiter ces informations. La diversité des formats impose le développement de logiciels suffisamment génériques pour être facilement adaptés à ceux-ci. Un premier défi est donc de gérer l'hétérogénéité des formats. En plus de leurs formats, les données recèlent des informations importantes que nous devons comprendre afin de pouvoir les traiter. Cependant, le manque de structure cache la sémantique des informations. Un deuxième défi est d'extraire la sémantique des données. Les problèmes causés par l'hétérogénéité des formats et le manque de structures sont exacerbés par l'incroyable quantité de données disponibles sur le web. Un troisième défi est de développer des logiciels qui passent à l'échelle et peuvent donc gérer une grande quantité de données. Enfin, pour exploiter toutes ces informations, les utilisateurs ont besoin de visualiser, transformer, comparer, explorer, chercher et éditer ces données. Par conséquent, nous devons traiter les mêmes données dans des services variés. Un quatrième défi est de développer des abstractions et des algorithmes qui peuvent supporter l'hétérogénéité des services.

Dans cette thèse, nous étudions le cas de ce que l'on appelle les Matrices de Comparaison de Produits (MCP). Les MCP sont largement utilisés pour documenter et comparer un ensemble de produits. Leur objectif est de modéliser la variabilité contenue dans ces produits, c'est à dire comment les produits diffèrent les uns des autres. Les MCP abondent sur le web et sont disponibles dans plusieurs formats (p. ex. HTML ou CSV). Cependant, le support des MCP dans les logiciels est très limité. Ce sont donc des données utiles, non structurées mais rarement exploitées. Elles forment un cas d'étude intéressant pour les défis mentionnés précédemment. Nous présentons à présent ce que sont les MCP, pourquoi elles défient l'ingénierie logicielle et quelles sont nos contributions pour répondre à ces défis.

Matrices de comparaison de produits

Tous les jours, nous faisons des choix. Que ce soit pour l'achat d'une voiture, d'une veste, pour choisir une destination pour les vacances de cet été ou bien juste pour décider quoi cuisiner pour ce soir, à un moment, nous devons prendre une décision. Pour nous aider à prendre des décisions, nous définissons habituellement un ensemble de critères et nous recueillons les informations relatives

à chaque solution possible à la question. Ensuite, nous comparons les solutions d'après ces informations et finalement nous prenons notre décision. Quand le nombre et la complexité des solutions des critères augmentent, la quantité d'information devient plus difficile à traiter. Par exemple, choisir un téléphone parmi tous les téléphones existants en comparant toutes leurs caractéristiques est une tâche particulièrement difficile et longue. Nous finissons souvent par ignorer certaines marques et nous basons notre choix sur des caractéristiques extravagantes. Cela peut aboutir à un mauvais choix.

Pour éviter d'être submergé, une solution courante est d'organiser et résumer ces informations dans ce que l'on appelle une MCP. Une MCP documente un ensemble de produits (les solutions possibles à la question) par rapport à un ensemble de caractéristiques (critères). La MCP¹ du haut de la Figure 1.1 documente 5 téléphones (représentés par les lignes) par rapport à 4 caractéristiques (représentées par les colonnes). Par exemple, elle indique que le poids du premier téléphone a une valeur de 178g. La représentation matricielle d'une MCP fournit un format simple, générique et consis pour documenter une ligne de produit, c'est à dire un ensemble de produits partageant des points communs et présentant de la variabilité.

Une MCP n'est pas un artefact contemplatif. Son potentiel principal se révèle être la capacité de comparer, configurer ou recommander des produits. Une activité indissociable est la création et la maintenance de la MCP elle-même. Afin de supporter ces activités, nous avons besoin de visualiser, requêter, raisonner, traiter, importer et éditer des MCP. De plus, les MCP abondent sur le web. Ainsi, elles forment une grande source d'informations à propos de nombreux sujets, attendants d'être exploitées.

Énoncé du problème

Malgré sa simplicité apparente, il peut être difficile de créer ou exploiter une MCP. Le manque de formalisation provoque la présence d'informations ambiguës, hétérogènes et incertaines dans les MCP. La situation est exacerbée par la présence de nombreuses MCP disponibles sur le web. Un exemple typique d'ambiguïté dans les MCP est la cellule vide. Une cellule sans aucun contenu peut être interprétée de diverses façons. Une première interprétation possible est l'absence d'information. Une autre est la non pertinence d'une caractéristique pour un produit particulier (p. ex. si un téléphone n'a pas d'appareil photo, la résolution de l'appareil photo n'est pas pertinente et aucune valeur ne peut être fournie). Une cellule vide peut aussi montrer l'absence d'une caractéristique en contraste avec une marque distinctive (p. ex. une croix) montrant la présence de celle-ci dans d'autres cellules.

Pour illustrer l'hétérogénéité, nous pouvons penser au prix d'un produit. Le prix peut être représenté dans différentes monnaies, dans différentes échelles ou via des représentation symboliques. Dans tous les cas, le prix est clairement indiqué mais comparer ou traiter ces représentations hétérogènes peut être difficile.

Enfin, un créateur de MCP peut ne pas spécifier toutes les informations d'une manière précise. Par exemple, une application pour partager des photos peut supporter la communication Bluetooth uniquement pour recevoir des photos. Si cette information est représentée comme "partiellement supportée" pour la caractéristique Bluetooth d'une MCP, alors l'information est incertaine.

En outre, la nature des cellules des MCP et leurs relations sont souvent implicites. Dans les formats usuellement utilisés pour les MCP (p. ex. HTML, CSV ou Excel), il n'y a pas de notation spéciale pour spécifier si une cellule est un produit, une caractéristique ou simplement des données. De plus, la relation entre une cellule et le produit et la caractéristique correspondante est réalisée par la position de la cellule. Cela veut dire que la sémantique de la MCP est liée à sa syntaxe.

Tous ces éléments créent un fossé syntaxique et sémantique entre la représentation concrète d'une MCP et son interprétation humaine. Ce fossé impacte 3 catégories d'utilisateurs. Les éditeurs de MCP ne manipulent pas les concepts qui sont les plus proches de leur travail mais des cellules génériques qui ne portent pas de sémantique particulière. Les développeurs qui souhaitent implémenter un service ou dériver des analyses de données à partir d'une MCP sont impactés par l'ambiguïté et l'incertitude de la matrice. Cette complexité rend difficile le développement

¹C'est un extrait d'une MCP de Wikipedia disponible sur https://en.wikipedia.org/wiki/Comparison_of_smartphones

de capacités de requête et de raisonnement. De plus, le manque de concepts explicites requiert l'inférence des produits et des caractéristiques à chaque fois qu'ils sont nécessaires. Enfin, les utilisateurs finaux doivent comprendre et extraire des informations utiles depuis des MCP ambiguës, incertaines et hétérogènes. La comparaison d'un petit ensemble de produits peut vite devenir une tâche difficile.

En conséquence, les services fournis avec les MCP en lignes sont plutôt limités. Les sites web n'offrent pas toujours des opérations basiques de filtrage et de tri. Les MCP qui viennent avec des services innovants sont rares et abordent des types de produits spécifiques tels que les téléphones ou les drones. Pour surmonter ces problèmes, la formalisation des MCP est cruciale. Ainsi, la question principale de cette thèse est:

Comment formaliser les matrices de comparaison de produits?

Nous envisageons deux solutions pour répondre à notre question. La première consiste à formaliser directement les MCP via une approche basée sur les modèles (cf. partie gauche de la Figure 1.1). La seconde projette les MCP vers un autre formalisme : la modélisation de caractéristiques (cf. partie droite de la Figure 1.1). Les publications associées à nos contributions sont listées à la page 145.

Formalisation de MCP via méta-modélisation

Approche

Avec leurs représentations matricielles, les MCP peuvent être perçues comme une forme spéciale de tableaux. De nombreux modèles de tableaux [85,175,184] et techniques de formalisation ont été proposés [24,51,57,95,167,183,192]. De même, les MCP peuvent aussi être considérées comme des tableaux spécifiques. De considérables efforts de recherche ont été dédiés à l'étude des tableaux [15,56,68,69,86,94]. À la fois dans le domaine du traitement de tableaux et celui des tableaux, l'analyse de l'état de l'art montre qu'il n'existe aucun formalisme dédié aux MCP. Les modèles de tableaux ou de tableaux sont trop génériques (p. ex. le modèle de Wang [184]) ou manquent d'expressivité (p. ex. le modèle relationnel [64]). De plus, ils ne parviennent pas à représenter exactement la sémantique des cellules présentes dans les MCP, qui constitue un important aspect de ces matrices.

Pour répondre à ce manque de formalisme, nous étudions l'utilisation d'une approche basée sur les modèles pour notre première solution (cf. partie gauche de la Figure 1.1). Avec une approche basée sur les modèles, nous pouvons précisément définir la structure et la sémantique d'une MCP. Nous pouvons aussi définir ou dériver des structures appropriées pour requêter, raisonner et éditer des modèles de MCP. C'est particulièrement intéressant pour faciliter les différentes activités liées aux MCP.

L'élément central de notre première solution est un méta-modèle du domaine des MCP (cf. partie gauche de la Figure 1.1). Ce méta-modèle de domaine définit la structure et la sémantique des MCP. Un modèle qui est conforme à ce méta-modèle représente une formalisation d'une MCP particulière. Afin de faciliter la formalisation, nous développons des techniques automatiques qui transforment une MCP en un modèle de MCP [9].

Défis

L'élaboration d'une approche basée sur les modèles pour les MCP est une tâche difficile. Il n'y a pas d'expert mais plutôt une multitude de contributeurs qui créent des MCP sans suivre de règles générales. Il n'existe pas non plus de format commun sur lequel nous pouvons nous baser pour construire notre méta-modèle. Par conséquent, il y a un manque d'oracle pour nous assurer que notre formalisation est correcte.

En outre, le web contient au moins des milliards de tableaux qui sont potentiellement des MCP [51]. Construire un oracle manuellement semble donc non réaliste. Ce serait un travail très long et nous n'avons aucun moyen pour nous assurer que l'oracle couvre toute la complexité et diversité des MCP.

Pour construire notre approche, nous avons besoin d'explorer manuellement des exemples représentatifs de MCP. Un premier défi est de choisir un ensemble de MCP qui est intéressant

pour la conception de notre méta-modèle et assez petit pour être gérable par un humain. Un deuxième défi est de tester notre approche sur de nombreuses MCP afin de vérifier sa précision et sa robustesse. Un troisième défi est de concevoir un méta-modèle qui peut à la fois représenter précisément le domaine des MCP et être la base pour le développement de services. Relever ces défis est essentiel pour construire une formalisation des MCP qui est précise et appropriée pour les utilisateurs finaux.

Contribution : une approche basée sur les modèles pour la formalisation de MCP

Un processus itératif guidé par les données, les utilisateurs et les services

Afin de relever les défis précédents, nous proposons un processus itératif guidé par les données, les utilisateurs et les services afin de concevoir notre meta-modèle et notre transformation. Le processus se base sur la transformation automatique d'un grand ensemble de MCP en modèles de MCP. Nous utilisons Wikipedia comme source de MCP. L'encyclopédie contient plus de 1 500 000 tableaux qui sont potentiellement des MCP. La diversité des domaines et des contributeurs impliqués dans Wikipedia fait de l'encyclopédie un cas d'étude intéressant.

Pour initier notre processus, nous analysons manuellement des dizaines de MCP venant de Wikipedia afin de construire une première version de notre méta-modèle et de notre transformation. Ensuite, les modèles obtenus via cette transformation sont évalués selon :

- des analyses automatiques basées sur des statistiques et des tests métamorphiques [59]
- une vérification manuelle par des utilisateurs finaux
- les commentaires de développeurs de services basés sur notre méta-modèle

À partir de cette évaluation, nous affinons notre meta-modèle et notre transformation. Finalement, nous appliquons la nouvelle transformation sur notre ensemble de MCP et donc nous itérons notre processus.

Notre processus permet d'explorer automatiquement un grand ensemble d'exemples de MCP. L'évaluation des modèles de MCP nous permet d'identifier des MCP qui ne sont pas encore supportées par notre approche. Ainsi, cela guide la sélection de MCP à analyser manuellement. En résumé, notre processus itératif facilite la conception d'une approche basée sur les modèles pour un grand ensemble d'exemples de données.

Une solution de modélisation appropriée et précise pour les MCP

En suivant notre processus itératif, nous développons un ensemble de meta-modèles et de transformations pour la formalisation des MCP. L'élément central de notre approche est un meta-modèle du domaine des MCP [9]. Ses concepts principaux sont les caractéristiques, les produits et les cellules. Cela correspond à l'aspect ligne de produits d'une MCP. De plus, il contient un ensemble de concepts pour définir précisément la sémantique des cellules.

Afin de transformer des MCP en modèles de MCP, nous développons des algorithmes génériques pour détecter les types de cellules, l'orientation d'une MCP et extraire les différents concepts de notre meta-modèle. Ces algorithmes se basent sur un ensemble d'heuristiques inspirées des travaux du domaine du traitement de tableaux [57, 183].

En complément du meta-modèle du domaine, nous proposons un ensemble de meta-modèles spécifiques à une tâche. Ils permettent de réduire l'effort pour développer des services concernant la manipulation, l'édition, l'import et l'export de MCP. À partir de ces meta-modèles, nous implémentons de nombreux services dédiés aux MCP tels qu'un éditeur, un comparateur, un configurateur et des visualisations [10]. Nous développons aussi des importeurs et des exporteurs de MCP dans les formats HTML, CSV et Wikipedia.

Toutes nos contributions sont intégrées dans OpenCompare, un projet dédié à la formalisation et l'exploitation de MCP. OpenCompare est fourni sous licence logicielle libre et disponible sur opencompare.org.

Les commentaires donnés par 20 chercheurs et ingénieurs montrent que notre meta-modèle du domaine contient les concepts nécessaires pour la formalisation des MCP. L'évaluation de notre transformation sur 75 MCP venant de Wikipedia montre que nous sommes capable de formaliser automatiquement plus de 90% de leurs cellules. De plus, nous sommes capables de traiter la totalité de la version anglaise de Wikipedia et d'en extraire 1,5 millions de modèles de MCP. À partir de cet ensemble de données, nous pouvons importer et exporter 91% de modèles de MCP dans les formats HTML, CSV et Wikipedia. Cela montre que nos techniques supportent une grande diversité de MCP.

Finalement, les commentaires encourageants recueillis pendant nos nombreuses expériences de développement montrent la capacité de nos meta-modèles à fournir les concepts appropriés pour le développement d'analyses génériques de support outillé pour les MCP.

En résumé, la conception de notre approche est guidée par les données, le développement de services et les commentaires de divers utilisateurs. Par conséquent, notre formalisation est précise, exploitable par des services et appropriée pour les utilisateurs finaux.

Formalisation de MCP via la synthèse de modèles de caractéristiques

Approche

Comme expliqué précédemment, une MCP est une représentation d'une ligne de produit. Plusieurs langages peuvent être utilisés pour documenter une ligne de produits (p. ex. les modèles de caractéristiques, les modèles de décision ou les tableurs). La norme de facto est le modélisation de caractéristiques [46]. La sémantique claire des Modèles de Caractéristiques (MC) est appropriée pour atteindre notre objectif de formaliser les MCP. De plus, avoir un MC permet l'utilisation de techniques existantes et avancées pour le raisonnement sur les lignes de produits ou la génération de nouveaux artefacts. Par exemple, les MC peuvent être utilisés pour la vérification de modèles appliquée à une ligne de produits logiciels [172], la configuration automatique de produits [98], le calcul d'informations pertinentes [43], la communication avec des parties prenantes [45] ou la génération d'artefacts [31]. Par conséquent, nous étudions la synthèse de MC à partir de MCP pour notre seconde solution à l'objectif de cette thèse (cf. partie droite de la Figure 1.1).

Défis

Nous observons que la grande majorité des travaux sont consacrés à la synthèse de MC booléens à partir d'artefacts variés (p. ex. formules propositionnelles, descriptions de produits textuelles ou code source) [18, 29, 77, 78, 100, 101, 115, 125, 126, 165]. Une limite importante des algorithmes de synthèse de MC est le fait qu'ils privilégient souvent la précision plutôt que la qualité ou vice versa. Ainsi, le MC synthétisé ne représente pas exactement la ligne de produit et en même temps présente une hiérarchie appropriée. Le manque de précision aboutit à des produits non explorés ou non existants. Une hiérarchie approximative impacte négativement la lisibilité et l'exploitation d'un MC. De plus, les MC booléens ne parviennent pas à représenter le contenu des MCP qui se basent souvent sur des informations numériques ou textuelles (cf. partie supérieure de la Figure 1.1).

La précision, qualité et expressivité des MC synthétisés via les techniques existantes ne sont pas suffisantes pour la formalisation des MCP. Il y a un fossé syntaxique et sémantique clair entre les MCP et les MC. Un premier défi est de caractériser ce fossé et identifier un formalisme de modélisation de caractéristiques approprié qui est capable d'encoder les MCP. Un deuxième défi est de développer une technique de synthèse de MC précise, efficace et automatique capable de combler ce fossé. Enfin, un troisième défi est de tenir compte de la connaissance du domaine et de l'utilisateur afin d'obtenir un MC compréhensible.

Contribution : un algorithme de synthèse pour les modèles de caractéristiques attribués

Pour réduire le fossé entre les MC et les MCP, nous identifions une classe de MCP que nous appelons les matrices de configurations. Les matrices de configurations présentent une structure simple. Les caractéristiques sont représentées dans la première ligne et les produits le sont dans les lignes suivantes. Chaque cellule contient une seule valeur dont la sémantique est non ambiguë. Parmi les millions de MCP que nous analysons pendant cette thèse, 86.4% présentent la même structure simple. De plus, une grande part des cellules que nous avons observées contiennent une valeur booléenne, numérique ou textuelle précise qui pourrait être encodée dans une matrice de configurations. Ainsi, nous considérons les matrices de configurations comme étant l'entrée de notre algorithme de synthèse.

L'expressivité des matrices de configurations est supérieure à l'expressivité des MC. Pour complètement supporter ces matrices, nous étudions la synthèse de MC Attribués (MCA), une extension des MC qui peut exprimer des informations booléennes et numériques ainsi que des énumérations.

Pour répondre aux défis précédents, nous proposons la première technique pour synthétiser un MCA à partir de matrices de configurations [5]. Nous développons un ensemble d'algorithmes pour raisonner sur les matrices de configurations afin de synthétiser les éléments qui composent un MCA. Nous présentons en particulier un algorithme pour extraire des contraintes sur les attributs à partir de la matrice.

Pour améliorer la qualité des MCA résultants, nous développons un ensemble d'heuristiques logiques et ontologiques afin de guider la sélection de la hiérarchie du MCA [3]. Un algorithme de branchement optimal assure que la hiérarchie est légale par rapport à la matrice prise en entrée. Nous proposons aussi un environnement interactif pour compléter l'information sur les heuristiques grâce à l'utilisateur [7].

Notre évaluation sur 126 MC venant de domaines variés et 30 MC extrait à partir de MCP, démontre qu'une approche hybride, mélangeant des techniques ontologiques et logiques, fournit le meilleur support pour synthétiser un MC. Nous faisons aussi une évaluation empirique afin de tester le passage à l'échelle de notre approche en utilisant à la fois des matrices de configurations aléatoires et des exemples réels. Les résultats de notre évaluation montrent que notre approche peut gérer des matrices de configurations contenant jusqu'à 2 000 caractéristiques attribuées et 200 000 configurations distinctes en quelques minutes. En résumé, notre algorithme permet de produire efficacement un MCA précis et de haute qualité à partir d'une matrice de configurations.

Deux approches complémentaires

Avec nos contributions, nous donnons une description claire du domaine et des méthodes précises pour la formalisation de MCP existantes. Notre première solution constitue une approche générique et efficace pour la formalisation des MCP. La structure logique représentée par notre méta-modèle du domaine est proche de la représentation matricielle habituelle des MCP. De plus, notre méta-modèle fournit les concepts nécessaires pour formaliser la sémantique variée des cellules. Ainsi, notre première solution facilite le développement de techniques fondamentales d'édition, de manipulation et de visualisation.

Notre seconde solution adopte une structure complètement différente qui met l'accent sur les caractéristiques et leurs relations plutôt que sur les produits. Cela permet de passer à des techniques d'ingénierie de lignes de produits. La sémantique formelle des MCA ouvre à l'utilisation de techniques avancées existantes pour le raisonnement. Cependant, notre seconde solution ne peut être appliquée uniquement sur une classe de MCP. De plus, la transition d'un modèle de MCP à un MCA peut potentiellement demander un effort important à la fois de calcul et pour l'utilisateur. Nos solutions fournissent deux vues différentes sur le même MCP et peuvent supporter différents services. Ce sont deux approches complémentaires pour la formalisation de MCP.

En créant deux approches pour le même problème, nous pouvons mettre en avant le compromis entre les deux solutions. Notre travail ouvre de nouvelles perspectives pour le développement de services innovants à partir de MCP extrait de sources variées. Nous fournissons aussi les abstrac-

tions et les algorithmes nécessaires au développement de transformations vers d'autres formalismes tels que les MC, les ontologies et les tableurs. En résumé, nous fournissons une approche générique et extensible pour la formalisation et l'exploitation de MCP.

Abstract

Product Comparison Matrices (PCMs) are widely used for documenting or comparing a set of products. They provide a compact representation of the characteristics or features of the products in the form of a product by feature matrix. The expected benefits of such simple format are the ease of use and definition. However, there exist no standard, guidelines or specific tool support for creating PCMs. The various domains addressed in PCMs and the numerous contributors leads to a large diversity in the structure and content of these matrices. This creates a syntactic and semantic gap between the concrete representation of a PCM and its human interpretation. To address this problem, the objective of this thesis is to develop techniques for formalizing PCMs. We explore two possible solutions to reach our objective.

Our first solution is to directly model PCMs through the use of a model-based approach. The central element of our approach is a domain metamodel that defines the structure and semantics of PCMs. It is completed by a set of transformations for automatically formalizing existing PCMs into PCM models. In our context, the elaboration of a model-based approach is a challenging task. The lack of standard or oracle hinders the evaluation of our approach. The presence of potentially millions of PCMs on the Web makes the manual building of an oracle unrealistic. To address these challenges, we propose an iterative process driven by data, end-users and services. It helps to evaluate our approach on a large number of PCMs while guiding the selection of a few PCMs to manually analyze. To ease the development of services on top of PCM models, we also create task-specific metamodels in relation to the edition, manipulation, import and export of PCMs.

Our second solution is the synthesis of Feature Models (FMs) from PCMs. Similarly to PCMs, FMs represent product lines which are sets of products sharing commonalities and presenting variabilities. FMs are the most widespread formalism for modeling product lines. They allow to develop reasoning capabilities and numerous applications such as generating comparators or configurators which can be beneficial for PCMs. Yet FMs provide a different view on a product line than PCMs. PCMs also contain types of data that cannot be represented by FMs. To address this problem, we consider as input of our algorithm, a class of PCMs that we call configuration matrices. Such matrices present a simple structure and contain data that can be represented by FMs. We also target an extension of FMs called Attributed FMs (AFMs) as output of our algorithm. AFMs allow the modeling of common types of data in PCMs such as booleans, numbers and enumerations. The analysis of the state of the art reveals that there exist no algorithm for synthesizing AFMs. Moreover, existing synthesis techniques often foster precision over quality of the resulting FM or vice versa. This hinders the exploitation of the generated FM. We improve state of the art of FM synthesis with techniques that produce FMs that both exactly represent the information contained in the input and exhibit a meaningful hierarchy. Then, we extend this technique to produce AFMs from configuration matrices. These improvements contribute to allow a qualitative and precise formalization and exploitation of a class of PCMs through the use of AFMs.

With our contributions, we provide two generic, extensible and complementary approaches for the formalization and exploitation of PCMs. This is a first step towards the creation of a community of users and contributors of PCMs. It opens new perspectives for the development of innovative services on top of PCMs coming from various sources.

Contents

Résumé en français	iii
Abstract	xi
1 Introduction	1
1.1 Context	1
1.2 Product Comparison Matrices	1
1.3 Problem Statement	2
1.4 Formalizing PCMs Via Metamodeling	3
1.4.1 Approach	3
1.4.2 Challenges	4
1.4.3 Contribution: A Model-Based Approach for the Formalization of PCMs	4
1.5 Formalizing PCMs Via the Synthesis of Feature Models	5
1.5.1 Approach	5
1.5.2 Challenges	5
1.5.3 Contribution: A Synthesis Algorithm for Attributed Feature Models	6
1.6 Two Complementary Approaches	6
1.7 Outline	6
I State of the Art	9
2 Product Comparison Matrices	11
2.1 Product lines	11
2.2 Product Comparison Matrices	12
2.3 Table Processing	13
2.3.1 Models of Tables	14
2.3.2 Extracting Table Models	14
2.3.3 Large Scale Extraction of Table Models	15
2.4 Spreadsheets	16
2.4.1 Reverse Engineering Spreadsheets	16
2.4.2 Model-based Spreadsheets	16
2.5 Exploitation of PCMs	17
2.5.1 Main Services	17
2.5.2 Noteworthy Implementations	18
2.6 Modeling PCMs	19
2.6.1 Model-Driven Engineering	19
2.6.2 Metamodeling	19
2.6.3 Designing a metamodel	20
2.7 Conclusion	20

3	Feature Modeling	23
3.1	Variability Modeling	23
3.1.1	Feature Models	23
3.1.2	Configuration and Ontological Semantics	25
3.1.3	Extended Feature Models	25
3.2	Synthesis of Feature Models	26
3.2.1	Definition and Properties	26
3.2.2	Synthesizing Feature Models	28
3.2.3	Reverse Engineering Feature Models	29
3.2.4	Tool support	30
3.3	Conclusion	30
II	OpenCompare: a Framework for Product Comparison Matrices	33
4	A Model-Based Approach Driven By Data, Users and Services	35
4.1	The Wikipedia Case Study	35
4.2	Problem Statement	37
4.3	Challenges	38
4.4	An Iterative Process Driven by Data, Users and Services	38
4.4.1	Initialization	39
4.4.2	Evaluating Our Metamodel and Transformation	39
4.4.3	Bootstrapping	40
4.5	Conclusion	40
5	Automating the Formalization of PCMs	41
5.1	The PCM Metamodel	41
5.2	The Transformation Chain	42
5.2.1	Parsing	42
5.2.2	Preprocessing	43
5.2.3	Extracting Information	44
5.3	Evaluation	45
5.3.1	Experimental Settings for RQ1 and RQ2	45
5.3.2	RQ1: Is our metamodel complete and relevant to the formalization of PCMs?	46
5.3.3	RQ2: What is the precision of our transformation of raw PCMs to PCM models?	47
5.3.4	RQ3: Is our metamodel suited for engineering automated analyses and services dictated to PCMs?	49
5.4	Threats to Validity	51
5.4.1	Internal Validity	51
5.4.2	External Validity	51
5.5	Conclusion	51
6	A Multi-Metamodel Approach	53
6.1	Going From One Metamodel to Multiple Metamodels	53
6.2	Manipulation and analysis of PCMs	54
6.3	Edition of PCMs	55
6.4	Importing and Exporting PCMs	56
6.4.1	A Unified Format	56
6.4.2	Importing PCMs	57
6.4.3	Exporting PCMs	58
6.5	Evaluation	59
6.5.1	Experimental settings for RQ1 and RQ2	59
6.5.2	RQ1: Is our metamodel complete and relevant to the formalization of PCMs?	59
6.5.3	RQ2: What is the precision of our transformation of raw PCMs to PCM models?	61

6.5.4	RQ3: Is our metamodel suited for engineering automated analyses and services dedicated to PCMs?	62
6.6	Threats to Validity	63
6.6.1	Internal Validity	63
6.6.2	External Validity	65
6.7	OpenCompare: An Initiative around PCMs	65
6.8	Conclusion	65
III	From Product Comparison Matrices to Feature Models	67
7	Breathing Ontological Knowledge into Feature Model Synthesis	69
7.1	From PCM to FM	69
7.2	Ontologic-aware Synthesis	71
7.2.1	The Importance of Ontological Semantics	73
7.2.2	Ontologic-aware FM Synthesis Problem	74
7.3	Automated Techniques for Feature Hierarchy Selection	74
7.3.1	Sound Selection of a Hierarchy	75
7.3.2	Logical Heuristics	75
7.3.3	Ontological Heuristics	78
7.3.4	Logic + Ontologic = Hybrid	81
7.4	Tool Support	81
7.4.1	Implementation of Ontological Heuristics	82
7.4.2	Features of the environment	82
7.4.3	Interactive edits of parent candidates and clusters	84
7.5	Evaluation	84
7.5.1	Experimental Settings	84
7.5.2	RQ1: Fully Automated Synthesis	86
7.5.3	RQ2: Quality of ranking lists and clusters	88
7.5.4	Summary and Discussion	94
7.6	Threats to Validity	95
7.6.1	External Validity	95
7.6.2	Internal Validity	95
7.7	Conclusion	96
8	Synthesis of Attributed Feature Models from Product Descriptions	99
8.1	From PCM to AFM	99
8.1.1	Product Comparison Matrices and Feature Models	99
8.1.2	Attributed Feature Models	101
8.2	Synthesis Formalization	102
8.2.1	Synthesis Parametrization	103
8.2.2	Over-approximation of the Attributed Feature Diagram	105
8.3	Synthesis Algorithm	105
8.3.1	Extracting Features and Attributes	105
8.3.2	Extracting Binary Implications	106
8.3.3	Defining the Hierarchy	107
8.3.4	Computing the Variability Information	107
8.3.5	Computing Cross Tree Constraints	107
8.4	Evaluation on Random Matrices	108
8.4.1	Initial Experiments with Or-groups	109
8.4.2	Scalability with respect to the number of variables	109
8.4.3	Scalability with respect to the number of configurations	110
8.4.4	Scalability with respect to the maximum domain size	110
8.4.5	Time Complexity Distribution	111
8.5	Evaluation on Real Matrices	111
8.5.1	Experimental Settings	111

8.5.2 Scalability	112
8.6 Threats to Validity	112
8.7 Discussion	113
8.8 Conclusion	114
IV Conclusion and Perspectives	117
9 Conclusion	119
9.1 Formalizing PCMs Via Metamodeling	119
9.2 Formalizing PCMs Via the Synthesis of Feature Models	120
9.3 How to Formalize Product Comparison Matrices?	122
9.4 Towards the Formalization of Unstructured Data	122
10 Perspectives	125
10.1 From PCMs to FMs	125
10.1.1 User Effort	125
10.1.2 Extended Support of PCMs	125
10.2 Metamodeling	126
10.2.1 Machine Learning for Metamodeling	126
10.2.2 Comparison of Model-Based Approaches	126
10.3 Wikipedia Case Study	127
10.4 OpenCompare	127
V Appendices	129
A Detailed Results of Statistical Tests	131
B Theoretical Analysis of AFM Synthesis Algorithm	135
B.1 Soundness and Completeness	135
B.1.1 Valid and Comprehensive Computation of Binary Implications	135
B.1.2 Proof of Soundness of the Synthesis Algorithm	136
B.1.3 Proof of Completeness of the Synthesis Algorithm	136
B.2 Maximality	136
B.3 Complexity analysis	138
B.3.1 Extracting Features and Attributes	138
B.3.2 Extracting Binary Implications	138
B.3.3 Defining the Hierarchy	138
B.3.4 Computing the Variability Information	139
B.3.5 Computing Cross Tree Constraints	139
B.3.6 Overall Complexity	140
List of Figures	141
List of Tables	143
Author’s publications	145
Bibliography	147

Chapter 1

Introduction

"Choice. The problem is choice."

Neo

1.1 Context

The amount of useful data in the world is estimated to be 16 zettabytes in 2020 [55]. Most of this information is unstructured and comes in a variety of formats (*e.g.* spreadsheets, JSON, XML, text). It is often created by numerous contributors without using standards or following guidelines. Examples abound on the Web such as wikis (*e.g.* Wikipedia), video and audio files or web services APIs [53, 55].

All this unstructured data challenges the engineering of software that can process this information. The variety of formats requires to develop software that is generic enough to be easily adapted to new formats. A first challenge is thus to handle the heterogeneity of formats. In addition to its format, the data holds important information that we need to understand in order to be able to process it. However, the lack of structure hides the semantics of the information. A second challenge is to extract the semantics of the data. The problems caused by the heterogeneity of formats and the lack of structure are exacerbated by the incredible amount of data available on the Web. A third challenge is to develop scalable software that can manage a large amount of data. Finally, to exploit all this information, users need to visualize, transform, compare, explore, search and edit the data. Therefore, we need to process the same data in various services. A fourth challenge is to develop abstractions and algorithms that can support the heterogeneity of services.

In this thesis, we study the case of what we call Product Comparison Matrices (PCMs). PCMs are widely used for documenting and comparing a set of products. Their objective is to model the variability contained in these products, *i.e.* how the products differ from each other. They abound on the Web and come in a variety of formats (*e.g.* HTML or CSV). Yet, the support of PCMs in software is extremely limited. As such, they are useful and unstructured data but rarely exploited. They form an interesting use case for the challenges mentioned previously. We now present what are PCMs, why they challenge software engineering and what are our contributions to address these challenges.

1.2 Product Comparison Matrices

Everyday, we make choices. Whether we want to buy a car or a jacket, choose a destination for this summer's holidays or just decide what to cook for tonight, at some point, we need to take a decision. To help us taking decisions, we usually define a set of criteria and gather the related information for each possible solution of the question. Then, we compare the solutions based on this information and finally we take our decision. As the number and complexity of solutions and

criteria increase, the amount of information becomes harder to process. For instance, choosing the appropriate smartphone among all the existing ones by comparing all their characteristics is a particularly difficult and time-consuming task. We often end up ignoring some arbitrary brands and base our choice on fancy features. This may lead us to the wrong choice.

To avoid being overwhelmed, a common solution is to organize and summarize this information in what we call a PCM. A PCM documents a set of products (possible solutions to the question) regarding a set of features (criteria). The PCM¹ at the top of Figure 1.1 documents 5 smartphones (represented as rows) according to 4 features (represented as columns). For example, it indicates that the *weight* of the first smartphone has a value of *178g*. The tabular representation of a PCM provides a simple, generic and concise format for documenting a product line, *i.e.* a set of products sharing commonalities and presenting variabilities.

A PCM is not a contemplative artifact. Its main potential lies in the ability to compare, configure or recommend products. A related and inevitable activity is the creation and maintenance of the PCM itself. In order to support all these activities, we need to visualize, query, reason, process, import and edit PCMs. Moreover, PCMs abound on the Web. As such, they form a great source of information about numerous subjects, waiting to be exploited.

1.3 Problem Statement

Despite their apparent simplicity, it can be cumbersome to create or exploit PCMs. The lack of formalization causes PCMs to contain ambiguous, heterogeneous and uncertain information. The situation is exacerbated by the presence of numerous PCMs available on the Web. A typical example of ambiguity in PCMs is the empty cell. A cell with absolutely no content can be interpreted in various ways. A first possible interpretation is the absence of information. Another one is the irrelevance of the feature for a particular product (*e.g.* if a smartphone has no camera, the resolution of the camera is irrelevant and no value can be provided). An empty cell can also denote the absence of a feature in contrast to a distinctive mark (*e.g.* a cross) noting the presence of this feature in other cells.

To illustrate heterogeneity, we can think about the price of a product. The price can be represented in different currencies, in different scales or with symbolic representations. In all cases, the price is clearly stated but comparing or processing heterogeneous representations can be difficult.

Finally, a creator of a PCM may not specify all the information in a precise manner. For instance, an application for sharing pictures may support Bluetooth communication only for receiving pictures. If this information is represented as "partially supported" for the feature Bluetooth communication of a PCM, then the information is uncertain.

In addition, the nature of cells in PCMs and their relations are often implicit. In common formats used for PCMs (*e.g.* HTML, CSV or Excel), there is no special notation to specify if a cell is a product, a feature or simple data. Moreover, the relation between a cell and its corresponding product and feature is realized by the position of the cell. It means that the semantics of the PCM is based on its syntax.

All these elements create both a *syntactic and semantic gap between the concrete representation of a PCM and its human interpretation*. This gap impacts 3 kinds of users. Editors of PCMs do not manipulate the concepts that are the closest to their task but generic cells that carry no specific semantics. Developers that want to implement a service or derive data analysis from a PCM are impacted by its ambiguity and uncertainty. This complexity hinders the development of querying and reasoning capabilities. Moreover, the lack of explicit concepts requires to infer products and features each time they are needed. Finally, end-users have to understand and extract useful information from an ambiguous, uncertain and heterogeneous PCM. The comparison of a small set of products can quickly become a tedious task.

As a result, the services provided with online PCMs are rather limited. Websites do not always offer basic filtering and sorting capabilities. The PCMs that come with innovative services are rare

¹This is an excerpt of a PCM from Wikipedia available at https://en.wikipedia.org/wiki/Comparison_of_smartphones

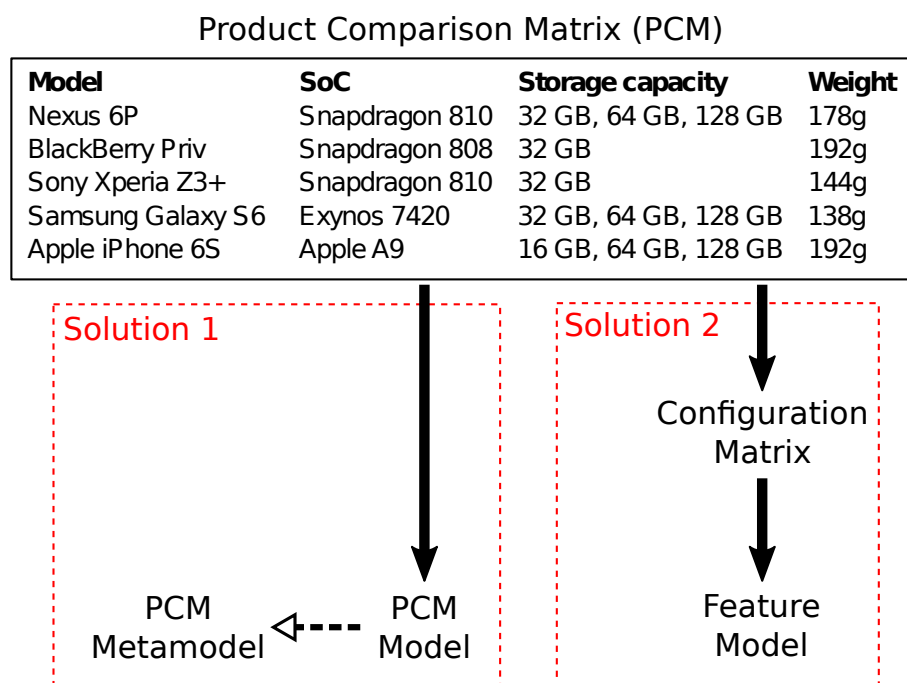

Figure 1.1: How to formalize product comparison matrices?

and address specific types of products such as smartphones or drones. To overcome these problems, the formalization of PCMs is crucial. Therefore, the main question of this thesis is:

How to formalize product comparison matrices?

We consider two solutions to address our question. The first one consists in directly formalizing PCMs through a model-based approach (see left of Figure 1.1). The second one maps PCMs to another formalism: feature modeling (see right of Figure 1.1). We now present in details these two complementary approaches. The publications associated to our contributions are listed on page 145.

1.4 Formalizing PCMs Via Metamodeling

1.4.1 Approach

By their tabular representation, PCMs can be perceived as a special form of tables. Numerous models of tables [85, 175, 184] and formalization techniques have been proposed [24, 51, 57, 95, 167, 183, 192]. Similarly, PCMs can also be considered as specific spreadsheets. Considerable research effort has been dedicated to the study of spreadsheets [15, 56, 68, 69, 86, 94]. In both table processing and spreadsheet domains, the analysis of the state of the art shows that there exists no formalism dedicated to PCMs. Models of tables and spreadsheets are either too generic (*e.g.* Wang’s model [184]) or lack of expressiveness (*e.g.* relational model [64]). Moreover, they fail to represent the exact semantics of cells present in PCMs which is an important aspect of such matrices.

To address this lack of formalism, we consider the use of a model-based approach in our first solution (see left of Figure 1.1). With a model-based approach, we can precisely define the structure and semantics of a PCM. We can also design or derive appropriate structures for querying, reasoning and editing models of PCMs. This is particularly interesting for easing the different activities related to PCMs.

The central element to our first solution is a metamodel of the domain of PCMs (see left of Figure 1.1). This domain metamodel defines the structure of PCMs and their semantics. A model

which conforms to this metamodel represents a formalization of a particular PCM. To ease the formalization, we develop automated techniques that transform a raw PCM into a PCM model [9].

1.4.2 Challenges

The elaboration of a model-based approach for PCMs is a challenging task. There is no identified expert but rather a multitude of contributors creating PCMs without following general guidelines. Neither does a common format exist on which we can rely to base our metamodel. Therefore, there is a lack of oracle to assess that our formalization is correct.

In addition, the Web contains at least billions of tables that are potentially PCMs [51]. Therefore, manually building an oracle seems unrealistic. It would be a very time-consuming task and we have no way to ensure that the oracle covers all the complexity and diversity of PCMs.

To build our approach, we need to manually explore representative examples of PCMs. A first challenge is to choose a set of PCMs that is interesting for the design of our metamodel and small enough to be manageable by a human. A second challenge is to test our approach on numerous PCMs in order to assess its precision and robustness. A third challenge is to design a metamodel that both accurately represents the domain of PCMs and can be the basis for the development of services. Addressing these challenges is essential for building a formalization of PCMs that is precise and relevant to end-users.

1.4.3 Contribution: A Model-Based Approach for the Formalization of PCMs

An Iterative Process Driven by Data, Users and Services

To address the previous challenges, we propose an iterative process driven by data, users and services in order to design our metamodel and transformation. The process relies on the automated transformation of a large dataset of PCMs into PCM models. We consider Wikipedia as a source of PCMs for our dataset. The encyclopedia contains more than 1,500,000 tables that are potentially PCMs. The diversity of domains and contributors involved in Wikipedia makes it an interesting case study.

To initiate our process, we manually analyze tens of PCMs from Wikipedia in order to build a first version of our metamodel and transformation. Then, the models obtained with this transformation are evaluated according to:

- automated analyses based on statistics and metamorphic testing [59]
- manual checking by end-users
- feedback from developers of services based on the metamodel

Based on this evaluation, we refine our metamodel and transformation. Finally, we apply the new transformation on the dataset of PCMs and thus iterate our process.

Our process allows to automatically explore a large set of examples of PCMs. The evaluation of the PCM models helps us to identify PCMs that are not yet supported by our approach. Therefore, it guides the selection of PCMs to analyze manually. Overall, our iterative process eases the design of a model-based approach for a large dataset of examples of data.

A Relevant and Accurate Modeling Solution for PCMs

Following our iterative process, we develop a set of metamodels and transformations for the formalization of PCMs. The central element of our approach is a domain metamodel for PCMs [9]. Its main concepts are features, products and cells which correspond to the product line view of a PCM. In addition, it contains a set of concepts for defining the precise semantics of cells.

To transform raw PCMs into PCM models, we develop generic algorithms for detecting types of cells, the orientation of a PCM and extracting the different concepts of our metamodel. These algorithms rely on a set of heuristics inspired from works in the domain of table processing [57, 183].

In complement to the domain metamodel, we propose a set of task-specific metamodels. They allow to reduce the effort for developing services regarding the manipulation, edition, import and export of PCMs. Based on these metamodels, we implement numerous services dedicated to PCMs such an editor, a comparator, a configurator, visualizations [10]. We also develop importers and exporters of PCMs in HTML, CSV and Wikipedia formats.

All our contributions are integrated in OpenCompare, a framework dedicated to the formalization and exploitation of PCMs. OpenCompare is released under free software license and available online at opencompare.org

The feedback gathered on 20 researchers and engineers shows that our domain metamodel contains the necessary concepts for the formalization of PCMs. The evaluation of our transformation on 75 PCMs from Wikipedia show that we are able to automatically formalize more than 90% of their cells. In addition, we are able to process the totality of the English version of Wikipedia and extract 1.5 million PCM models. From this dataset, we can correctly import and export 91% of the PCM models in HTML, CSV and Wikipedia formats. This shows that our techniques support a large diversity of PCMs.

Finally, the encouraging feedback gathered during our numerous development experiments shows the ability of our metamodels to provide the appropriate concepts for the development of generic analyses and tool support for PCMs.

Overall, the design of our approach is driven by the data, the development of services and the feedback of our various users. As a result, our formalization of PCMs is accurate, exploitable by services and relevant to end-users.

1.5 Formalizing PCMs Via the Synthesis of Feature Models

1.5.1 Approach

As we explained, a PCM is a representation of a product line. Multiple languages can be used to document a product line (*e.g.* feature models, decision models or spreadsheets). The de facto standard is feature modeling [46]. The clear semantics of Feature Models (FMs) is appropriate for addressing our objective of formalizing PCMs. Moreover, having an FM enable the use of existing advanced techniques for reasoning on the product line or generating new artifacts. For instance, FMs can be used for model checking a software product line [172], automating product configuration [98], computing relevant information [43], communicating with stakeholders [45] or generating artifacts [31]. Therefore, we consider the synthesis of FMs from PCMs for our second solution to the objective of this thesis (see right of Figure 1.1).

1.5.2 Challenges

We observe that, the large majority of work is focused on the synthesis of Boolean FMs from a variety of artifacts (*e.g.* propositional formulas, textual product descriptions or source code) [18,29,77,78,100,101,115,125,126,165]. An important limitation is that existing FM synthesis algorithms often foster precision over quality or vice versa. As a consequence, the resulting FM does not both exactly represent the input product line and exhibit a meaningful hierarchy. The lack of precision leads to unexplored or non existing products. An approximate hierarchy negatively impacts the readability and further exploitation of an FM. Moreover, Boolean FMs fail to represent the content of PCMs which often rely on numerical or textual information (see top of Figure 1.1 for an example).

The precision, quality and expressiveness of FMs synthesized with existing techniques are not sufficient for the formalization of PCMs. There is a clear syntactic and semantic gap between PCMs and FMs. A first challenge is to characterize this gap and identify an appropriate feature modeling formalism capable of encoding PCMs. A second challenge is to develop a precise, efficient and automated FM synthesis technique capable of bridging this gap. Finally, a third challenge is to take into account domain knowledge and user input in order to obtain a meaningful FM.

1.5.3 Contribution: A Synthesis Algorithm for Attributed Feature Models

To reduce the gap between FMs and PCMs, we identify a class of PCMs that we call configuration matrices. Configuration matrices present a simple structure. Features are represented in the first row and products in the subsequent rows. Each cell contains a single value whose semantics is unambiguous. Among the millions of PCMs that we analyzed during this thesis, 86.4% presents the same simple structure. Moreover, a large part of the cells that we observed contain a precise Boolean, numerical or textual value which could be encoded in a configuration matrix. As such, we consider configuration matrices as input of our synthesis algorithm.

The expressiveness of configuration matrices exceeds the expressiveness of FMs. To fully support such matrices, we explore the synthesis of Attributed FMs (AFMs), an extension of FMs that can support Boolean or numerical information and enumerations.

To address the previous challenges, we propose the first technique for synthesizing AFMs from configuration matrices [5]. We develop a set of algorithms to reason on the configuration matrix in order to synthesize the elements that compose an AFM. In particular, we present an algorithm for extracting constraints on attributes from the input matrix.

To improve the quality of the resulting AFM, we develop a set of logical and ontological heuristics in order to guide the selection of the hierarchy of the AFM [3]. An optimum branching algorithm ensures that the hierarchy is legal with respects to the input matrix. We also propose an interactive environment to complement the information of the heuristics with user input [7].

Our empirical evaluation on 126 FMs coming from various domains and 30 FMs extracted from PCMs, demonstrates that a hybrid approach, mixing ontological and logical techniques, provides the best support for fully synthesizing FMs. We also perform an empirical evaluation to test the scalability of our approach by using both randomized configuration matrices and real-world examples. The results of our evaluation show that our approach can scale up to configuration matrices containing 2,000 attributed features, and 200,000 distinct configurations in a couple of minutes. Overall, our algorithm allows to efficiently produce a precise and high quality AFM from a configuration matrix.

1.6 Two Complementary Approaches

With our contributions, we provide a clear description of the domain and accurate methods for formalizing existing PCMs. Our first solution provides a generic and efficient approach to the formalization of PCMs. The logical structure represented by our domain metamodel is close to the usual matrix representation of PCMs. Moreover, our metamodel provides the necessary concepts to formalize the various semantics of cells. As such, our first solution eases the development of basic edition, manipulation and visualization techniques.

Our second solution present a completely different structure that focuses on the features and their relations instead of the products. It allows to switch to product line engineering techniques. The formal semantics of AFMs enables the use of existing advanced reasoning techniques. However, our second solution can only be applied on a class of PCMs. Moreover, the transition from a PCM model to an AFM can potentially require high computational or user effort. Our solutions provide two different views on the same PCM and can support different services. They are two complementary approaches to the formalization of PCMs.

By creating two approaches for the same problem, we can highlight the trade-off between the two solutions. Our work opens new perspectives for the development of innovative services on top of PCMs extracted from various sources. We also offer the necessary abstractions and algorithms to develop transformations to other formalisms such as FMs, ontologies and spreadsheets. Overall, we provide a generic and extensible approach for the formalization and exploitation of PCMs.

1.7 Outline

The thesis is organized as follows:

Part I describes the basic notions and background for the next parts. It also analyze existing work related to the formalization of PCMs.

Chapter 2 presents PCMs in details and related work on spreadsheets and tabular data.

Chapter 3 presents existing techniques for modeling product lines and precisely defines what is an FM. It also explains the properties of FM synthesis techniques and discusses the limitations of existing techniques.

Part II presents our model-based approach for formalizing PCMs.

Chapter 4 introduces the case study of Wikipedia and identify challenges for the elaboration of a model-based approach for PCMs. It also details our iterative process for addressing these challenges.

Chapter 5 presents a metamodel and transformation for automatically formalizing PCMs which results from a first iteration of our process. The metamodel and the techniques are evaluated on hundreds of PCMs from Wikipedia.

Chapter 6 presents in detail a second iteration of our process focusing on the development of services for editing, manipulating and exploiting PCMs. It also evaluates these techniques on millions of PCMs coming from Wikipedia.

Part III presents techniques to synthesize AFMs from PCMs.

Chapter 7 presents a new technique for integrating user knowledge and heuristics in FM synthesis. The technique is evaluated on 126 FMs coming from the SPLOT repository and 30 FMs extracted from Wikipedia PCMs.

Chapter 8 presents a new technique for synthesizing attributed FMs from a class of PCMs. The evaluation is focused on the scalability by measuring execution time on randomly generated matrices and realistic PCMs from the *BestBuy* website.

Part IV concludes the thesis and presents new perspectives.

Chapter 9 highlights our main contributions and discuss the benefits and limits of the two presented solutions regarding our main objective.

Chapter 10 opens new perspectives for improving the support of PCMs and presents the future of OpenCompare.

Part I

State of the Art

Chapter 2

Product Comparison Matrices

"Unfortunately, no one can be told what the Matrix is.
You have to see it for yourself."

Morpheus

In this chapter, we first explain what is a product line and how it is related to Product Comparison Matrices (PCMs) (see Section 2.1). Then, we define what is a PCM and give insights about the complexity that lies behind (see Section 2.2). In Section 2.3, we explore the state of the art for formalizing PCMs and tabular data in general. Then, we continue this exploration by focusing on spreadsheets which can be considered as a generalization of PCMs (see Section 2.4). Finally, we describe the services and activities that can be derived from a PCM and highlights the limits of current implementations (see Section 2.5). In these sections, we identify a lack of specific formalism for PCMs and significant limits in existing tool support. Therefore, we discuss how metamodeling techniques can be used to formalize PCMs and propose a basis for developing tool support (see Section 2.6).

2.1 Product lines

Customers increasingly want products specifically tailored to their needs. The "one size fits all" product introduced by the development of mass production is no longer desired. The well known *Ford model T* has been replaced by numerous different car models that propose thousands of configuration options. To adapt to this situation, companies shift from mass production to mass customization. Mass customization still consists in the production of a large amount of products but each product is personalized for a particular customer. To keep a low unit cost and reduce time to market, the products are not developed individually but as a product line [145].

The same idea has been applied to software. For instance, the Linux kernel is managed as a single project from which an immeasurable number of variants are derived [140]. The kernel contains thousands of configuration options. Many other examples of software product lines are used everyday (*e.g.* Firefox, Windows or ffmpeg).

The idea is to build a set of products from a common platform and introduce variability to be able to derive customized products. Weiss *et al.* defines variability as "an assumption about how members of a family may differ from each other" [186]. Therefore, each product is composed of a set of features that can be shared with other products. Multiple definitions of a feature exist [61]. For example, a feature can be "a prominent or distinctive user-visible aspect, quality or characteristic" [117] or "an increment in product functionality" [42]. It also can be "an elaboration or augmentation of an entity that introduces a new service, capability or relationship" [41]. A feature can cover every aspect of a product from user requirements to technical details. The composition of features can be constrained to avoid defective or unrealistic products or meet commercial requirements.

Model	SoC	Storage capacity	Weight
Nexus 6P	Snapdragon 810	32 GB, 64 GB, 128 GB	178g
BlackBerry Priv	Snapdragon 808	32 GB	192g
Sony Xperia Z3+	Snapdragon 810	32 GB	144g
Samsung Galaxy S6	Exynos 7420	32 GB, 64 GB, 128 GB	138g
Apple iPhone 6S	Apple A9	16 GB, 64 GB, 128 GB	192g

Cell

Features

Products

Figure 2.1: Description of a PCM

Product lines are often designed by a single company in order to create a set of personalized products. A common practice is to use either a top-down or a bottom-up approach. The top-down approach consists in first creating a model (*e.g.* a feature model as we will describe in Chapter 3) of the product line describing the different features of the product line and their constraints. Then, we implement each feature separately. Finally, for each valid combination of feature of the model, a product is generated.

The bottom-up approach consists in starting from existing products that are managed individually. Then, we model the variability contained in the considered products. If necessary, we refactor the products into a single product line.

In this thesis, we adopt a broader view of products lines. We consider that any set of related products is a product line even if no product line engineering techniques has been used for their development. For example, the products of Figure 2.1 are manufactured by different companies but present similar characteristics.

In this context, both vendors and customers need a precise documentation of a product line. Creators use such documentation to foresee and master the variability contained in the product line that they are building. For users, the documentation is essential to fully explore the products of the product line. This becomes critical as the number of products and features increase. For that matter, a widespread and simple solution is to document a product line with a PCM [46]. Another solution is to use feature models as we will detail in Chapter 3.

2.2 Product Comparison Matrices

A PCM documents the products and features of a product line in a tabular format [156]. For example, the first row of the PCM of Figure 2.1 defines 4 features: **Model**, **SoC**, **Storage capacity** and **Weight**. The following rows represents 5 smartphones which compose the product line being documented. Each cell specifies the value of a feature regarding a product. For example, the cell highlighted in the figure indicates that the **weight** of the first smartphone has a value of **178g**.

Such simple format allows everyone to quickly present an overview of a product line. This favors the creation of numerous PCMs that now abound on the web. In particular, commercial websites heavily use PCMs to describe and compare their products. PCMs are also used in magazines or displayed in shops for the same purposes. Overall, the expected good properties of PCMs are:

- simplicity: no particular training is required to understand how it works.
- synthesis: all the "expected" information is present, without any verbose claim.
- easy to write and define from scratch or from existing sources (*e.g.* textual product descriptions or databases).
- independent from any particular domain. For example, there are PCMs about software, cars, ski resorts, tax preparation or dosimeters.
- independent from any particular support. PCMs can be found in various electronic formats such as HTML or CSV. Some are stored in databases or accessible through APIs. Moreover, there are PCMs printed in magazines or displayed in shops.

- universal: the simplicity and profusion of PCMs makes them accessible to everyone. Reading or writing a PCM do not require any particular training.

Yet, the massive use of PCMs and the lack of standard lead to a great diversity in existing PCMs [12]. A first source of diversity is the format used to store and distribute PCMs. PCMs can be found in classic HTML pages but also in a variety of file formats (*e.g.* CSV, PDF or image files). PCMs can also be stored in databases or accessed through APIs.

A second source of diversity is the way the information is organized in a PCM. The example of Figure 2.1 presents a simple structure. However, PCMs may be organized in different and sometimes more complex representations. For instance, products and features can be inverted, *i.e.* products are depicted as columns and features as rows. Features can be decomposed in sub-features in order to further organize the PCM. Some PCMs further structure their information with cells spanning the total width of the matrix. Usually, such cells represent a feature that can be used to separate products in categories.

A third source of diversity lies in the content of the cells. Without guidelines or standard, the editors of PCMs may introduce complex or ambiguous information. This goes from empty cells that may have different meanings depending on the situation to large pieces of text that details everything that the editor could not organize in other features. In addition, the type of information that a cell contain may vary. For instance, in Figure 2.1 we observe textual information for the features Model and SoC. The feature Storage capacity contain lists of numerical information expressed in gigabytes. Finally, the feature Weight contain numerical information expressed in grams.

In this diversity of structure and cell content, we can identify patterns of variability information [54, 156]. The objective of the thesis is to explore how we can formalize the variability contained in PCMs.

Bibliographic Study The natural representation of a PCM is a table. For instance, the `<table>` tag of HTML is often used to represent PCMs. Another practice is to use CSV files or spreadsheets. PCMs can thus be considered as a special case of table or spreadsheet. Therefore, we organize our bibliographic study as follows. First, we study the state of the art of table processing. In particular, we present existing models of tables and techniques to automatically extract these models from raw tables (see Section 2.3). Then, we present various works on the modeling of spreadsheets and discuss their adequacy to the domain of PCMs(see Section 2.4). In Section 2.5), we show how PCMs can be exploited to provide numerous services. We also list examples of noteworthy implementations of services for PCMs and highlight their limits. Finally, we discuss existing modeling techniques for helping in the elaboration a metamodel for formalizing PCMs (see Section 2.6).

2.3 Table Processing

By their matrix representation, PCMs can be considered as a special form of table. Numerous work have been devoted to processing table [85, 192]. Table processing consists in transforming a raw table into a table model which is in direct relation to our main objective.

Raw tables can be represented in multiple medias (*e.g.* images, scanned documents or electronic documents) and formats (*e.g.* HTML or CSV). In their survey, Embley *et al.* describe different paradigms of table processing [85]. In particular, they highlight the significant amount of work focusing on the processing of images or scanned documents based on image processing and OCR techniques. PCMs can be found in these kinds of documents. However, the formalization of PCMs is not related to a particular format. In addition, the Web represents a large source of unexploited PCMs. This is why in this thesis, we focus on electronic formats with a clear structure for tables such as HTML, CSV or Wikitext. As such, the works mentioned by Embley *et al.* could be used to provide further inputs to our algorithms.

Table processing techniques allows the development of various applications such as tabular browsing, manipulation or database creation. Depending on the intended application, different models or formalisms can be used as output [85, 192]. In the following, we explore existing table models and table processing techniques that could be used for formalizing PCMs.

2.3.1 Models of Tables

Precisely defining what is a table is a difficult task [127]. Table models can greatly differ depending on the format of the table, its domain and the expected application. A widespread formalism for tables is the relational model introduced by Codd [64]. It consists in a set of n attributes and a collection of n -tuples. Each attribute has a fixed position, a label and is defined on a domain.

Wang *et al.* propose a table model with a clear separation of logical and presentational aspects [184]. This model accepts a wide range of tables with for example the support of multidimensional tables. Its separation of concerns and genericity makes it a good model for formalizing tables in general.

Ontologies can also be used for formalizing tables [175,183]. As defined by Gruber, "an ontology is an explicit specification of a conceptualization" [96]. It precisely defines a set of concepts and their relations [97]. Tijerino *et al.* aim to extract the semantics of the information contained in a table and encode them into ontologies [175]. Wang *et al.* address a similar problem in order to enrich the existing Probase ontology [183]. Compared to previous table models, ontologies are more focused on the semantics of the information contained in a table. In particular, this favors the development of reasoning techniques.

Regarding the main objective of this thesis, the simplicity of the relational model prevents a precise formalization of PCMs. For example, the hierarchy of features cannot be represented as well as the complex semantics of cells. Moreover, the fixed positions of attributes may hinder the development of services for PCMs which are sometimes based on the reorganization of products and features. Contrary to the relational model, the expressiveness of the Wang's model [184] is sufficient for representing the complex structures in PCMs. However, the model is too generic for PCMs and would result in unused concepts or relations. Moreover, the precise semantics of the content of the cells cannot be represented and is restricted to a domain. Finally, we are not aware of an ontology dedicated to PCMs.

Overall, the problem of formalizing PCMs with a table model has not been addressed in the field of table processing. Existing models are too generic (*e.g.* Wang's model [184]) or lack of expressiveness (*e.g.* relational model [64]) to precisely represent the logical structure and semantics of PCMs. Yet some interesting properties (*e.g.* separation of concerns) or organization (*e.g.* structure as n -tuples) could be reused or adapted in our context.

2.3.2 Extracting Table Models

According to Hurst *et al.*, table processing can be separated in 4 steps: "table location; table recognition; functional and structural analysis; and interpretation" [111,112]. Table location and recognition respectively consists in discovering tables in documents and deciding if a table matches a given table model or not. Significant research effort have been dedicated to these two steps based on various properties, transformations (*e.g.* image processing algorithms or tree transformations) and inferences (*e.g.* classifiers or parsers) [192].

For instance, Wang *et al.* exploits machine learning techniques such as decision trees and support vector machines made for detecting tables in HTML documents [185]. Their classification is mainly based on the layout and content of the table. Such techniques could be adapted to PCMs by exploiting their specific properties. However, decisions made by location and recognition techniques are relative to a table model. As we are investigating the formalization of PCMs, these two operations are not yet possible. This is why, we will assume in the thesis that the location and recognition of PCMs are performed by a human or are made trivial by the format and context of the matrix. Therefore, we will focus on the functional and structural analysis as well as the interpretation of tables which consist in extracting the logical structure and semantics of a table.

As we mentioned previously, the Web forms a great source of tables and PCMs. HTML is the standard format on the Web. Processing HTML tables is a difficult challenge that has been addressed by several works [24,51,57,95,167,183]. The HTML language offer a set of dedicated tags for tables that are focused on the structural representation with low level elements such as rows and cells. The tag *th* allows to differentiate a normal cell from a head cell. The tag *thead* allows to group these headers and further separate the content of the table from its headers. Despite their existence, *th* and *thead* tags are not always used. Moreover, the lack of constraints or guidelines

leads to misuses such as using *th* tags for defining all the cells. Overall, the expressiveness of the HTML language is very limited to define the semantics of a table and its elements and the few existing concepts cannot be trusted in general.

To extract the logical structure of an HTML table, Chen *et al.* use specific algorithms and heuristics [57]. They are based on both the structure of the table (*e.g.* number of cells) and its content (*e.g.* type of data or similarity between cells). The algorithm outputs a list of attribute-value pairs and is evaluated on tables about airline information.

Wang *et al.* uses similar heuristics to extract information from tables [183]. For example, they rely on syntactic clues (*e.g.* bold font) and differences in data types to extract the schema of a table. The originality of this work comes from the use of the Probase ontology to guide the extraction of the table. In particular, if a schema cannot be found, the ontology is used to find the most likely concepts for each column and infer a schema. Probase is also used to detect the column that defines the different entities that are compared or specified in the table. At the end, the extracted information is injected in Probase in order to enrich the ontology. A limit of this technique is the hypothesis that the attributes (or features) are always depicted as columns and entities (or products) as rows.

Tijerino *et al.* also target an ontology as output for their extraction technique [175]. To build their ontology they first encode the tables in the relational model. Similarly, in our formalization process, we use an intermediary format to ease the transition between a raw table and its final formalism.

To avoid the complexity of the HTML language and the diversity of implementations of tables, Gatterbauer *et al.* base their technique on the visual representation used by browsers [95]. Their abstraction allows to focus on the actual positions of the cells rather than the structure imposed by HTML.

In addition to HTML tables, some works extended their extraction process to spreadsheets. As we will see in detail in Section 2.4, spreadsheets can also represent PCMs. For instance, Shigarov *et al.* use a set of rules based on the structure of the table or the graphical format of the cells [167]. From this information, a rule engine infer the logical structure of the table. In addition, a dictionary of synonyms is used to further refine the extracted table model.

Another type of technique is presented by Adelfio *et al.* that uses machine learning techniques to extract a schema of a table [24]. More specifically, they use conditional random fields to classify the rows of a table. From this classification, they extract a schema which can be exploited to store the table in a relational database. We note that their technique is focused on rows only and do not infer the semantics of the content of the cells.

2.3.3 Large Scale Extraction of Table Models

The Web constitutes a great source of PCMs and tables in general. Cafarella *et al.* extracted 14.1 billion of raw HTML tables with Google’s web crawler [51]. Among them, 154 million were recognized as relational tables. Their analysis of the dataset shows that relational tables are small in general with 2 to 9 columns for 93% of the dataset. Their work is the basis for the development of the WebTables project.

The project consists in a set of algorithms and services for exploiting tables on the Web. They use classification techniques and hand-written heuristics to detect tables and recover their metadata. The output of their algorithms is a relational table. The formalization and exploitation of a large corpus of tables ease the development of search engines or auto-complete capabilities for tables [50]. We note that WebTables assumes that the headers of a table are represented in a single row. This represents a limit for the formalization of PCMs which may contain several rows of headers to represent the features to compare.

In this thesis, we are also facing the challenge of processing and formalizing a large amount of tables. For instance, in Part II, we focus our study on PCMs coming Wikipedia website. We estimate that the English version of the encyclopedia contains more than one million tables.

2.4 Spreadsheets

In addition to their tabular nature, PCMs can also be seen as a special form of spreadsheet with specific characteristics and objectives. Considerable research effort has been devoted to the study of spreadsheets [103,143]. All studies have the same observation: errors in spreadsheet are common but non trivial.

Due to the profusion of errors, catalogs of smells in spreadsheets have been proposed to characterize the practices that may introduce maintainability or comprehension issues [69,104]. For instance, Cunha *et al.* elaborated a catalog of smells based on the analysis of numerous spreadsheets from the EUSES corpus [90]. Based on this catalog, they developed a tool called SmellSheet Detective that automatically detects these smells [69]. Similarly, Hermans *et al.* transposed smells of object-oriented development [91] to spreadsheets [104]. In addition, they propose metrics to detect the presence of a smell. The detected smells are presented with data flow diagrams that are automatically extracted from the spreadsheet [107].

2.4.1 Reverse Engineering Spreadsheets

As spreadsheets are subject to errors and ambiguity, some works propose to synthesize high-level abstractions or to infer some information. For instance, Chambers *et al.* describe a mechanism to infer *dimensions* (*i.e.* units of measures) [56]. They start by statically analyzing the structure of a spreadsheet in order infer cells that are headers. Then, they use lexical analysis to extract dimensions from the headers. Finally, they propagate the information on dimensions through formulas.

Abraham *et al.* define a type system for spreadsheets [16]. They use heuristics to classify cells and to infer headers from the layout of the spreadsheet. The headers are used as units for cells. Then, their type system exploits these units to check if the different references and formulas are consistent. To further detect errors, they also propose a fine-grained type system that analyzes each formula and cell in a spreadsheet [15]. The starting point of this type system is the primitive types of cells: numerical, string, Boolean and undefined. Their type systems can automatically detect inconsistencies in formulas regarding the nature of the data that are manipulated.

Another research direction is to elicitate the domain information stored in spreadsheets. For instance, Hermans *et al.* proposed to synthesize class diagrams based on the analysis of a spreadsheet [106]. They assembled a library of common patterns in spreadsheets. They use different parsing and pattern matching algorithms to identify these patterns. Finally, they map each located pattern to an equivalent class diagram fragment.

Hermans *et al.* propose to use data flow diagrams as another possible representation of the information contained in spreadsheets [107]. They describe an algorithm for extraction such diagrams based on a set of heuristics on the nature of cells and their structure. They also developed a user interface in order to ease the navigation and analysis of the data flow. To evaluate their approach, they interviewed 27 employees of a financial company. A majority of employees indicated that using such high-level abstraction could be beneficial for their work.

2.4.2 Model-based Spreadsheets

Constructive approaches for ensuring that spreadsheets are correct by construction have been developed in order to prevent typical errors associated with spreadsheets. For instance, Francis *et al.* [94] develop tools to consider spreadsheets as first-class models and thus enable the reuse of state of the art model management support (e.g., for querying a model).

ClassSheet [86] introduces a formal object-oriented model of a spreadsheet which can be used to automatically synthesize spreadsheets. It allows to define composable blocks of cells that uses attribute names instead of cell references in formulas. Moreover, it explicitly represent the vertical or horizontal expansions of data and formulas in a spreadsheet. To keep a familiar view, ClassSheet relies on an underlying grid layout. Typing rules ensures that ClassSheet models do not violate this layout. Finally, these models are translated to ViTSL [17]. ViTSL is a language for defining spreadsheet templates. From the template, a concrete spreadsheet can be generated.

To ease the definition of ClassSheet models, Cunha *et al.* propose an algorithm to automatically infer them from spreadsheets [68]. This can be used to refactor the existing spreadsheet and adopt a model-driven approach. Basically, they adapt methods to relational models to spreadsheets. In particular, they analyze the dependencies between cells to determine relational schemas in a spreadsheet. Then, they build a relation graph that explicit the relations between the schemas. Finally, they translate the graph into a ClassSheet model.

MDSheet propose to directly integrate ClassSheet models into spreadsheets [70]. The benefit is to offer a familiar view for defining ClassSheet models. MDSheet relies on a bi-directional transformation framework in order to maintain spreadsheet models and their instances synchronized. For instance, if a row is added in the model, the instances are automatically updated and their formulas are modified to take into account this new row. This avoids common errors when refactoring a spreadsheet.

In Part II of this thesis, we follow a similar model-based approach and the benefits also apply to our work. A notable difference is that we consider the specific nature of PCMs, i.e., we target a specific class of spreadsheets. The expressiveness of our formalization is not suited for dealing with many aspects of spreadsheets (e.g., worksheets, formulas, references).

2.5 Exploitation of PCMs

Despite their inherent complexity, PCMs can be the basis for numerous activities and services [12]. An objective of formalizing PCMs is to provide the necessary concepts and algorithms to support these activities. In the following, we list the main services that could be provided on top of PCMs. Then, we list some noteworthy implementations and highlight their limits.

2.5.1 Main Services

Compare. The main activity based on PCMs is the comparison of products. A user explores the information contained in the matrix and extract the important part for its objective (*e.g.* buy a particular product or discover a lack in the documented products). To ease the comparison, we could allow to sort and filter features according to a set of constraints. For example in Figure 2.1, one may filter out smartphones with a **Weight** superior to 180g and sort the **Storage capacity** in descending order. This allows to find a smartphone with a large storage capacity and a limited weight. Another functionality that can be interesting when comparing products in a PCM is to reorganize the features and products in order to reflect the preferences of the user.

Configure. An other activity closely related to comparison is configuration. Instead of exploring the entire PCM, we ask questions to the user in order to progressively reduce the configuration space. That way, the user is not overwhelmed by the mass of information that a PCM can contain.

Visualize. Specific vizualizations can be derived to further explore a PCM. For example, statistics and plots can be used to have a quick glimpse at the data.

Recommend. Databases, ontologies, informal textual documents or even other PCMs may contain complementary information that can enrich a PCM. A recommendation system could be built in order to detect and search related sources of information.

Edit. Creating or modifying a PCM can be difficult without tool support. A dedicated editor can ease these operations by allowing the user to manipulate the appropriate concepts (*e.g.* products and features instead of cells). Moreover, an editor could highlight inconsistent or ambiguous information. As a PCM grows or evolve over time, multiple persons may contribute to a single PCM. An editor with the support of collaborative edition and versioning system could ease the collaboration of different actors.

Import. Creating a PCM from scratch can be time-consuming. In some cases, the information that we want to include can be found in a file or accessible through an API. An import service can ease the integration of such information in a PCM. It consists in transforming the file format (*e.g.* CSV or PDF) or making the appropriate requests of the API to adapt the information to the PCM.

Export. To store or share a PCM, an export service can be necessary. It consists in transforming the information contained in the PCM to another format (*e.g.* an HTML file to be embedded in a website).

Generate. To go further than exporting a PCM, we can generate multifarious artifacts. For example, we can generate the source code of a configurator dedicated to a particular PCM.

Manipulate. To build all these services, we need to manipulate and operate on one or several PCMs. Operations such as merging, slicing or exposing a PCM through a dedicated API can ease their development.

2.5.2 Noteworthy Implementations

Considering the previous activities, we can observe that most of websites and software offer very limited abstractions, algorithms or services. Most of the time, the only possible operation consists in sorting the products according to one feature. We note some exceptions such as graphiq.com which allows to create visualizations and offer a comparator with advanced sorting and filtering capabilities. The website also offers a simple configurator to quickly filter the products according to a predefined set of features.

The objective of socialcompare.com is to create a community around PCMs. The website offers an editor dedicated to PCMs with specialized types of data and focused on the concepts of products and features. An interesting functionality is the recommendation of features and auto-completion of cells based on other PCMs from the website. Moreover, each PCM can be shared on social networks or embedded in other websites. A review system allows the members of the community to rate and comment PCMs. These sharing capabilities foster the collaboration between contributors. To compare products, the website offers a simple matrix view where we can move and remove features and products. The matrix can be sorted according to one feature. We note that the products are always represented as columns and that it is impossible to filter products based on the values of a feature. Moreover, the formalism or format used internally is not accessible.

The *django* `packages`¹ project offers a web interface for generating PCMs of packages for the *Django* web framework². The resulting PCM is purely static and none of the services mentioned previously are implemented.

Regarding the visualization of a product line, the website productchart.com propose an innovative graphical representation for comparing products. It displays the products in a 2D environment according to two criteria selected by the user. This allows to quickly detect the best product or find a compromise between the criteria. However, the product lines that are presented are defined by the creator of the website and concern only 7 different domains (*e.g.* laptops or 3D printers).

In another context, spreadsheet applications (*e.g.* Microsoft Excel, LibreOffice or Tableau) can provide ad hoc support for PCMs. For instance, it is quite easy to sort rows according to the value in one or several columns. It is also possible to generate charts and statistics based on the values in a spreadsheet. However, there is no special support for PCMs. They provide operations for manipulating rows and columns. They have no notion of products or features and the semantics of cells is usually implicit. In our context, spreadsheets can be considered as a general purpose language for manipulating tables and thus PCMs. The expressiveness of spreadsheets allow the development of various services that would not be possible with a language dedicated to PCMs. However, the abstractions that they offer is not always appropriate for the formalization and manipulation of PCMs.

¹<https://github.com/pydanny/djangopackages>

²<https://www.djangoproject.com/>

In the same vein as spreadsheets, CSV libraries provide generic operations that are interesting for the manipulation of PCMs. For example, the *F# Data* library³ automatically detect types of columns such as booleans, integers, floats, dates or units of measure. It also supports missing values. Regarding operations, it provides advanced filtering capabilities and is able to handle large CSV files. Yet, these CSV libraries do not cover all the complexity of PCMs such as the presence of multiple values in a cell (see the column *Storage capacity* of Figure 2.1). Moreover, the CSV format is simple and do not reflect the logical structure or semantics of PCMs.

As we observe, existing services for PCMs are often very limited. They do not provide abstractions or formalisms that are adapted to the formalization or exploitation of the comprehensive diversity and complexity of PCMs. The underlying formalism of the few projects that are explicitly dealing with PCMs is often not available. In addition, they do not support or ease the development of new services. This further motivates our main objective.

2.6 Modeling PCMs

Whether considering the field of table processing or spreadsheets, existing formalisms fail to precisely define PCMs. A major contribution of this thesis is the elaboration and evaluation of a metamodel of PCMs (see Part II). In this section, we define what is a metamodel and study related work that could help us to design a metamodel for PCMs.

2.6.1 Model-Driven Engineering

Model-Driven Engineering (MDE) is a development paradigm that uses models as primary artifacts to describe the different concerns and aspects of a software system [93]. A model acts as an abstraction of a part of the system for a given purpose [137]. There can be multiple purposes to a model such as documenting, analyzing, testing or driving the implementation of the system.

Schmidt describes MDE as a combination of Domain-Specific Modeling Languages (DSML) and transformations [159]. Contrary to general-purpose languages (*e.g.* Java or C++) which aim to be generic enough to cover any domain, DSMLs precisely capture the concepts and constraints of one particular domain [180]. DSMLs are used to define the different models that support MDE. Models are not contemplative artifacts but are the basis for supporting the whole life-cycle of a system [93]. For that purpose, transformations are developed in order to derive new artifacts (*e.g.* source code, documentation, test cases or other models) from a model.

To address our objective, we consider the use of MDE approaches. In particular, we design a DSML for the domain of PCMs and use different transformations to import and export PCMs, implement an editor, provide an API and create visualizations (see Part II).

2.6.2 Metamodeling

A common way to describe a DSML is to use a *metamodel*. A metamodel defines the concepts of the domain of the DSML and their relations. It describes the structure of the language, also called abstract syntax [152, 180]. Additional constraints can be provided to further restricts the abstract syntax. A model is conformant to a metamodel if the model instantiates the concepts of the metamodel and respects its constraints.

In Chapter 5, we design a metamodel for PCMs which defines the abstract syntax of a PCM. A model that conforms to this metamodel corresponds to a representation of a particular PCM. In our context, we face the challenge of supporting the large number of preexisting PCMs on the Web. Therefore, the metamodel should be expressive enough to cover the diversity of this dataset (see Section 2.2). For that matter, we now study techniques and guidelines that could help us to design our metamodel while taking into account the specificities of our context.

³<http://fsharp.github.io/FSharp.Data/library/CsvProvider.html>

2.6.3 Designing a metamodel

Numerous formalisms, techniques, or guidelines have been proposed to design a metamodel and DSMLs in general. For instance, Karsai *et al.* describe 26 guidelines for the development of DSMLs [119]. They indicate that some of these guidelines may conflict. This highlights the difficulty to design an appropriate DSML. It also shows the need to adapt the design to context of the DSML. Voelter *et al.* give a comprehensive view of how to design, implement and test such languages [179]. They also provide examples of DSMLs in three language workbenches: Xtext, MPS and Spoofox. Defining how to make a good metamodel or language can be difficult. Instead, Kelly *et al.* focuses on defining common errors or bad practices in the design of DSMLs [121]. To characterize these smells, they analyzed 76 DSMLs from various domains, technological space and creators.

In our context, the presence of numerous existing PCMs is an essential source of data to take into account during the design of our metamodel. For that purpose, example-driven approaches have been developed to ease the elaboration and improve the quality of metamodels [40]. For instance, De Lara *et al.* [67, 124] propose an interactive approach in which domain experts specify example model fragments that are then exploited for constructing a metamodel. Model fragments can be annotated by the experts to further guide the generation of the metamodel. The advantage of their approach is that domain experts can define what the metamodel should support without being a modeling expert. Moreover, the metamodel can be easily corrected by adding new model fragments.

Faunes *et al.* propose to complement a metamodel with well-formedness rules extracted from examples and counter-examples [88]. Their technique relies on genetic programming to infer OCL rules. Their evaluation on 2 metamodels (state machine and feature diagram) shows that they can retrieve relevant rules with a high precision and recall.

MARS is a semi-automatic system for retrieving a metamodel from a set of models expressed in XML [116]. The system uses a grammar inference engine to analyze the models and eventually infer a metamodel. To ease the work of the inference engine, the different metamodel elements are extracted from the XML files and represented into a specific DSML.

In another context, Cánovas *et al.* describe a model-based process to discover schemas in JSON data produced by web services [53]. They first convert JSON documents to low-level JSON models. Then, from a set of JSON models, they extract a schema in form of a metamodel. This extraction is based on a set of transformation rules from JSON models to metamodel fragments. Their approach supports the discovering of a metamodel for multiple web services by merging the resulting metamodels of each service.

The design of a metamodel is often performed by several modeling experts in concert with end-users. To ease this activity, Cabot *et al.* [113] propose a collaborative process to ease the definition of DSMLs. They define a DSML, called Collaboro, to support this activity. Collaboro provides the necessary abstractions to gather the annotations and modifications of a community during the design of a DSML. In particular, it allows to reference elements in the abstract and concrete syntax of the language. It also embeds a decision engine to automatically take design decision based on the votes of the community and multiple resolution strategies. Lanubile *et al.* highlights that more and more collaboration tools are emerging in global software engineering [123].

2.7 Conclusion

PCMs abound the Web. They are simple and compact representations of a product line. They form a great source of information that could be exploited for comparing, configuring, visualizing and recommending products. Other services such as editors or importers can facilitate the creation of PCMs. Despite their expected good properties, PCMs are subject to a lot of diversity that hinder the development of such services. We also observe the lack of websites or tools to manipulate PCMs. This further motivates the design of a formalism dedicated to PCMs.

PCMs can be seen as specific tables or spreadsheets. In both domains, considerable research effort have been devoted to define a formalism and automate the extraction of such formalism from raw data. Overall, our analysis of the state of the art does not reveal the existence of a formalism

dedicated to PCMs. However, we note that existing models or ontologies have interesting properties or concepts that could be reused in our context.

An important motivation of our work is to enable the exploitation of the millions of PCMs present on the Web by developing a set of generic algorithms and services. We aim to create a formalism that can act as a basis for such development. Metamodeling techniques are specially crafted for both defining a domain or language and build associated tool support. This is why we are investigating the design of a metamodel for PCMs. Our context forces us to take into account a large existing dataset. The problem of designing a metamodel from such large dataset has not been addressed yet. The lack of specific guidelines or techniques prompted us to manually analyze hundreds of PCMs and automatically process millions of tables in order to understand the PCM domain and finally design our metamodel. Part II explain in details our journey into the design of a metamodel for PCMs.

Chapter 3

Feature Modeling

"What happened, happened and could not have happened any other way."

Morpheus

As we explained previously, a PCM is a view on a product line. A product line is composed of a set of products presenting commonalities and variabilities. Its complexity can quickly become unmanageable and thus there is a need to model the product line. This is what we call variability modeling. Section 3.1 explains what variability modeling is and what are its possible benefits and applications. Then, it focuses on the most widespread formalism for variability modeling: feature models. The activity of modeling variability can be error-prone and time-consuming. In addition, the domain of PCMs represents millions of unexploited matrices. Section 3.2 investigates the synthesis of FMs from various artifacts. In particular, we define what is the problem of synthesizing an FM and what are the expected properties of the output FM. Finally, we explore existing approaches and identify their limits for our problem of formalizing PCMs.

3.1 Variability Modeling

Variability modeling consists in delimiting the scope of a product line and formally documenting its common and variable parts. This is a crucial activity in product line engineering and several formalisms have been proposed to model variability (*e.g.* orthogonal variability modeling [145], decision modeling [158] or feature modeling [117]). Among them, the most widespread and studied formalism is feature modeling [31, 43, 47, 110]. Once specified, Feature Models (FMs) can be used for model checking an SPL [172], automating product configuration [98], computing relevant information [43] or communicating with stakeholders [45]. In many generative or feature-oriented approaches, FMs are central for deriving software-intensive products [31]. For instance, the work of Murashkin *et al.* is close to the context of PCMs [138]. From an FM, they generate a graphical representation of a set of products in a 2 dimensions space. Each point represents a product. The position and the characteristic of the points provide an intuitive way to compare the products. Given the popularity of FMs and their extensive applications and tool support, we choose to focus on this particular formalism for the rest of the thesis.

3.1.1 Feature Models

Introduced by Kang *et al.* [117], FMs aim at characterizing the valid combinations of features (a.k.a. configurations) of a system under study. The main part of an FM is the feature diagram (see Definition 1). In this diagram, a feature hierarchy (a tree) is used to facilitate the organization and understanding of a potentially large number of features. In addition, different syntactic constructions are offered to attach variability information to features organized in the hierarchy.

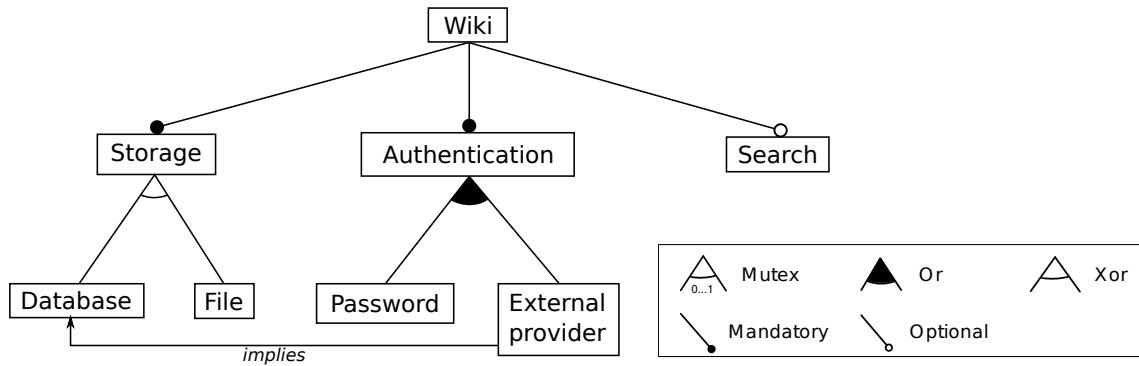

Figure 3.1: Example of a feature model of a product line for wiki software

Wiki	Storage	Authentication	Search	Database	File	Password	External provider
✓	✓	✓	✓	✓	✗	✓	✓
✓	✓	✓	✓	✓	✗	✓	✗
✓	✓	✓	✓	✓	✗	✗	✓
✓	✓	✓	✓	✗	✓	✓	✗
✓	✓	✓	✗	✓	✗	✓	✓
✓	✓	✓	✗	✓	✗	✗	✗
✓	✓	✓	✗	✓	✗	✗	✓
✓	✓	✓	✗	✗	✓	✓	✗

Table 3.1: Configurations of the FM of Figure 3.1

As an example, the FM of Figure 3.1 describes a family of Wiki engines. The FM states that Wiki has two *mandatory* features, Storage, Authentication and one *optional* feature Search. There are two alternatives for Storage: Database and File features form an *Xor*-group (*i.e.*, at least and at most one feature must be selected). In addition, the features Password and External provider form an *Or*-group of Authentication (*i.e.*, at least one feature must be selected). We refer to *Xor*, *Or* and *Mutex* groups as feature groups. Feature groups express a global constraint on a set of sibling features and their common parent. Cross-tree constraints over features can be specified to restrict their valid combinations. In the feature diagram, cross-tree constraints are limited to the following predefined forms of Boolean constraints: equals, requires and excludes. For instance, the feature External provider implies the feature Database. A similar abstract syntax is used in [29, 78, 165] while other dialects slightly differ [160].

Definition 1 (Feature Diagram). *A feature diagram is a 8-tuple $\langle G, E_M, G_{MTX}, G_{XOR}, G_{OR}, EQ, RE, EX \rangle$ where:*

- \mathcal{F} is a finite set of features
- $G = (\mathcal{F}, E)$ is a rooted tree where $E \subseteq \mathcal{F} \times \mathcal{F}$ is a set of directed child-parent edges ;
- $E_M \subseteq E$ is a set of edges that define mandatory features with their parents ;
- $G_{MTX}, G_{XOR}, G_{OR} \subseteq 2^{\mathcal{F}}$ are non-overlapping sets of edges participating in feature groups.
- EQ (resp. RE, EX) is a set of equals (resp. requires, excludes) constraints whose form is $A \Leftrightarrow B$ (resp. $A \Rightarrow B, A \Rightarrow \neg B$) with $A \in \mathcal{F}$ and $B \in \mathcal{F}$.

The following well-formedness rule holds: a feature can have only one parent and can belong to only one feature group.

The diagrammatic part of an FM is not expressive enough to represent any possible product line, *i.e.* any constraint on the combination of features [78]. To increase its expressiveness, the feature diagram is completed by an arbitrary formula which together form an FM (see Definition 2).

For example, let consider the fictive constraint: $\text{Search} \wedge \text{Password} \Rightarrow \text{Database}$. The feature diagram of Figure 3.1 cannot be modified such that it integrates the additional constraint. We must rely on an external constraint and thus we obtain an FM.

Definition 2 (Feature Model). *A feature model is a pair $\langle FD, \phi \rangle$ where FD is a feature diagram, and ϕ is a Boolean formula over \mathcal{F} .*

3.1.2 Configuration and Ontological Semantics

The essence of an FM is its *configuration semantics* (see Definition 3). For instance, the configuration semantics of the FM of Figure 3.1 can be represented as the PCM of Figure 3.1. The syntactical constructs of a FM are used to restrict the combinations of features authorised by an FM. For example, at most one feature can be selected in a Mutex-group. As such Mutex-groups semantically differ from optional relations. Mutex-groups also semantically differ from Xor-group – none of the features can be selected if the parent of a Mutex-group is selected. Formally, the cardinality of a feature group is a pair (i, j) (with $i \leq j$) and denotes that at least i and at most j of its k arguments are true. G_{MTX} (resp. G_{XOR} , G_{OR}) are sets of *Mutex-groups* (resp. *Xor-groups*, *Or-groups*) whose cardinality is $(0, 1)$ (resp. $(1, 1)$, $(1, m)$: m being the number of features in the Or-group).

The configuration semantics can be specified via translation to Boolean logic [78]. In particular, the configuration semantics states that a feature cannot be selected without its parent, i.e., all features, except the root, logically imply their parent. As a consequence, the *feature hierarchy also contributes to the definition of the configuration semantics*.

Definition 3 (Configuration Semantics). *A configuration of a feature model g is defined as a set of selected features. $\llbracket g \rrbracket$ denotes the set of valid configurations of g .*

Another crucial and dual aspect of an FM is its *ontological semantics* (see Definition 4). Intuitively the ontological semantics of an FM defines the way features are conceptually related. Obviously, the feature hierarchy is part of the ontological definition. The parent-child relationships are typically used to *decompose* a concept into sub-concepts or to *specialize* a concept. There are also other kinds of implicit semantics of the parent-child relationships, e.g., to denote that a feature is *implemented by* another feature [118]. Looking at Figure 3.1, the concept of Wiki is composed of different properties: Storage, Authentication and Search. Storage can be further refined in Database or File, etc. Feature groups are part of the ontological semantics (see Definition 4) since there exists FMs with the same configuration semantics, the same hierarchy but having different groups [18, 165]. For example, the FMs of Figure 3.1 and 3.4 have the same configuration semantics but present different ontological semantics.

Definition 4 (Ontological Semantics). *The hierarchy $G = (\mathcal{F}, E)$ and feature groups $(G_{MTX}, G_{XOR}, G_{OR})$ of a feature model define the semantics of features' relationships including their structural relationships and conceptual proximity.*

We use the term *ontological semantics* in line with the terminology employed in previous papers [75, 165]. In knowledge engineering, an ontology represents the semantics of concepts and their relationships using some description language (e.g., based on description logic) [36, 96]. Feature modeling shares the same goal and is also a concept description technique – less rich and powerful than ontology languages. We share the view of Czarnecki *et al.* stating that "*feature models are views on ontologies*" [75], the hierarchy and feature groups being central to the conceptualization of a domain.

3.1.3 Extended Feature Models

The FMs described previously are what we call Boolean FMs. Their syntax (see Definition 2) and semantics (see Definition 3) rely only on Boolean constructs. As we can observe in PCMs (see Section 2.2), other types of data or constraints can be used to describe product lines. To increase the expressiveness of FMs, several extensions have been proposed for the formalism.

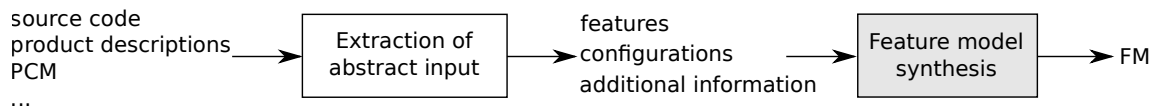

Figure 3.2: Derivation of an FM from various kinds of artifacts.

For instance, Czarnecki *et al.* propose to add *cardinalities* [73, 74] to features and group of features. Cardinalities denote how many clones of a feature or sub-tree of the hierarchy can be produced. This avoids to duplicate features and introduce complex constraints when the product line uses the similar features in multiple contexts. Quinton *et al.* further extends cardinality-based FMs by defining new types of constraints on cardinalities. They also develop reasoning techniques based on CSP and SAT solvers to check the consistency of cardinality-based FMs. [149, 150].

Another extension is the use of *attributes* [39, 44, 60, 71, 84]. In attributed FMs, the features are completed with attributes that can contain non Boolean values (*e.g.* numerical or textual). For example, an attribute can represent the weight of a product by a real number. We believe this extension can be the basis for formalizing PCMs and thus we investigate the synthesis of attributed FMs in Chapter 8.

Seidl *et al.* propose to model the versions of a feature through the use of *hyper FMs* [161]. Each feature is related to a set of versions and a partial order on these versions. Cross-tree constraints are also extended to express constraints on the versions. In a sense, hyper FMs can be considered as specialized attributed FMs.

Finally, Czarnecki *et al.* present probabilistic FMs [77]. In this extension, probabilities are used to describe uncertainty or preferences in the choice of features. For example, we could model that the feature `Database` in the PCM of Figure 3.1 is used in 80% of the installations of Wiki software.

Overall, various extensions exist to cross the boundary of FMs and their Boolean semantics. We could benefit from such extensions for addressing our objective of formalizing PCMs. However, as reported in [43], the vast majority of research in feature modeling has focused on Boolean FMs.

3.2 Synthesis of Feature Models

3.2.1 Definition and Properties

Based on the definition of She *et al.* [163], we define FM synthesis as following:

Definition 5 (Feature Model Synthesis). *FM synthesis is the process of deriving an FM from the following abstract input:*

- a set of features
- a set of valid configurations expressed either directly or via a set of constraints on the features
- additional information that can guide the synthesis (*e.g.* information on the hierarchy of the synthesized FM)

The abstract input of Definition 5 is rarely present as such in product lines. However, it can be extracted from various artifacts related to a product line such as source code or textual requirements (see Section 3.2.3). In the following, we refer to the process of both extracting the abstract input and synthesizing an FM as *reverse engineering* an FM (see Figure 3.2 for an overview). Before exploring the state of the art of FM synthesis and reverse engineering, we define the properties that can be used to characterize such techniques. Regarding the output FM, there are 3 main properties: precision, maximality and quality.

The precision of a technique gives us information on the configuration semantics of the synthesized FM compared to the input artifacts. Following the vocabulary of [163], a sound algorithm (see Definition 6) will produce an FM that is an under-approximation of the set of configurations represented by the input. Soundness ensures that subsequent exploitation of the FM is safe but it leads to unexploited products.

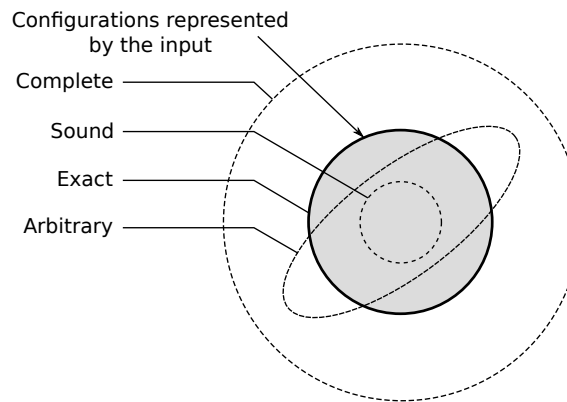

Figure 3.3: Precision of an FM synthesis algorithm according to the input configurations (adapted from Figure 5 of [163])

Definition 6 (Soundness of Feature Model Synthesis). *A synthesis algorithm is sound if the resulting FM (fm) represents only configurations that exist in the input (in), i.e. $\llbracket fm \rrbracket \subseteq \llbracket in \rrbracket$.*

On the contrary, a complete algorithm (see Definition 7) will produce an FM that is an over-approximation of the input. Completeness ensures that the full capacity of the product line can be exploited. However, users of the FM may be exposed to non existing products. A sound and complete algorithm will produce an FM that exactly represents the input configurations. If an algorithm is neither sound or complete, we consider that it has an arbitrary precision. Figure 3.3 resumes the different levels of precision of an FM synthesis algorithm.

Definition 7 (Completeness of Feature Model Synthesis). *A synthesis algorithm is complete if the resulting FM (fm) represents at least all the configurations of the input(in), i.e. $\llbracket in \rrbracket \subseteq \llbracket fm \rrbracket$.*

The maximality of a synthesis algorithm (see Definition 8) ensures that the output FM is not trivial (e.g. an FM with the input configurations encoded in the constraint Φ and no hierarchy, i.e. $E = \emptyset$). Intuitively, maximality enforces that the feature diagram contains as much information as possible.

For example, the FM of Figure 3.4 has the same configuration semantics as the FM of Figure 3.1. However, it is not maximal. The mandatory relations of **Storage** and **Authentication** are represented in the constraint ϕ of the FM (see right of Figure 3.4). The Xor-group of **Database** and **File** and the *implies* constraint between **External provider** and **Database** are also expressed in ϕ . To be maximal, these constructs must be represented in the diagrammatic part of the FM.

A consequence of the lack of maximality is the presence of counter-intuitive information in the FM. For instance, the **Storage** is mandatory but it is represented as an optional. To understand that the feature is mandatory, one must carefully analyze all the constraints.

Definition 8 (Maximal Feature Model). *An FM is maximal if its hierarchy H connects every feature in F and if none of the following operations are possible without modifying the configuration semantics of the FM:*

- add an edge to E_M
- add a group to G_{MTX} , G_{XOR} or G_{OR}
- move a group from G_{MTX} or G_{OR} to G_{XOR}
- add a constraint to the feature diagram that is not redundant with other constraints of the feature diagram or the constraints induced by the hierarchy and feature groups.

Finally, the quality of the FM represents the quality of its ontological semantics. As we will see in Chapter 7, the ontological semantics of an FM impacts its exploitation. For instance, if the features are organized in a natural way for the expert of the domain, its readability is greatly

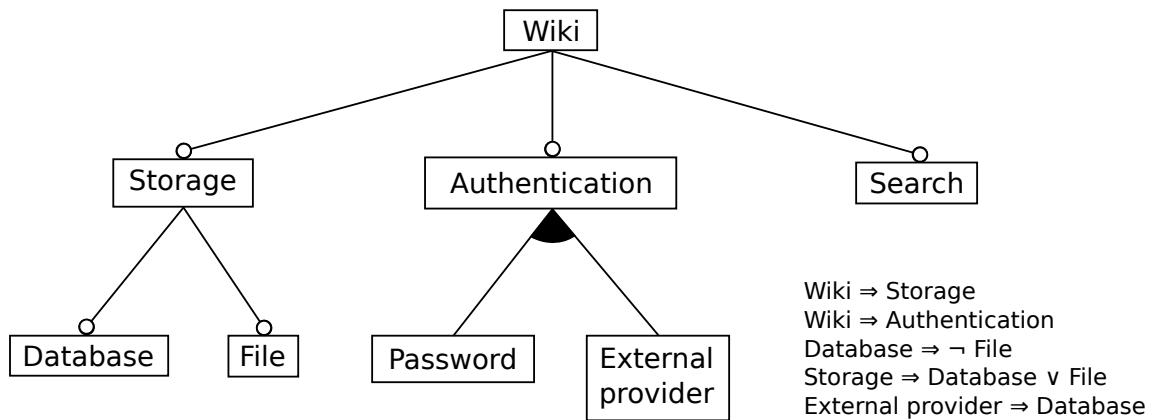

Figure 3.4: A non maximal FM with the same configuration semantics as Figure 3.1

improved. Another example is the generation of a configurator from the FM. If the hierarchy is badly organized, the questions will reflect this organization and may impact the usability of the generated configurator.

Other properties can be used to characterize an FM synthesis algorithm. For example, we will address the reduction of *user effort* in Chapter 7. In Chapter 8, we focus on the *scalability* of our synthesis algorithm. Measuring such properties for one algorithm can be tricky. To have a fair and precise comparison of the different approaches of the state of the art, we focus mainly on the 3 properties that we detailed previously. For other properties, we only give some insights and notable information mentioned in the articles.

3.2.2 Synthesizing Feature Models

Techniques for synthesising an FM from a set of constraints (e.g., encoded as a propositional formula) or from a set of configurations (e.g., encoded in a product comparison matrix) have been proposed.

Czarnecki *et al.* describe the relation between FMs and propositional formulas [78]. They propose an algorithm that calculates a diagrammatic representation of *all possible* FMs. It leaves open the selection of the hierarchy and feature groups. The algorithm mainly relies on the resolution of satisfiability problems with binary decision diagrams. The output of the algorithm present an overapproximation of the input propositional formula. They also adapted their algorithm to the synthesis of Probabilistic FMs [77].

Andersen *et al.* propose an extension of the previous algorithm in order to improve its efficiency [29]. Instead of using binary decision diagrams, they rely on SAT solvers and binary integer programming. They describe two algorithms for supporting formulas respectively in conjunctive and disjunctive normal form. In addition, they synthesize an additional constraint ϕ which results in an exact representation of the input formula.

Haslinger *et al.* propose an algorithm to synthesize an FM from a table representing the valid configurations of the FM [100, 101]. The input format is similar to the PCM represented in Figure 3.1. The algorithm directly works on the table to extract the different elements of an FM. We note that the selection of the hierarchy is guided by the logical implications between the features.

She *et al.* propose an algorithm to synthesize a sound and complete FM from a propositional formula [165]. The main focus of their work is to provide an heuristic to rank the correct parent features in order to reduce the task of a user. Though the synthesis procedure is generic, it assumes the existence of textual descriptions of the different features. They evaluate their approach on three large software projects: Linux, eCos, and FreeBSD. She *et al.* reported in Section 7 of their article [165] that their attempts to fully synthesize an FM did not lead to a desirable hierarchy – such as the one from reference FMs used in their evaluation – coming to the conclusion that an additional expert input is needed.

Similarly, Acher *et al.* describe an algorithm to synthesize an FM from a propositional formula [18]. Instead of relying on a heuristic, their procedure processes user-specified knowledge for organizing the hierarchy of features. The provided knowledge is a subset of the different elements of the desired FM. If the knowledge is sufficient and consistent with the formula, the algorithm results in an FM that exactly represent the formula and exhibit the desired hierarchy.

Previous works mainly rely on computing the satisfiability of a set of configurations or constraints in order to build an FM. Lopez-Herrejon *et al.* propose a different approach with the use of search-based algorithms [125, 126]. The input of their synthesis algorithm is a table similar to the one of Figure 3.1 that represents a set of configurations. In their procedure, candidate FMs are encoded in two arrays, one for representing the hierarchy and one for the cross-tree constraints. They propose two fitness functions for their evolutionary algorithm. The first one is based on the number of configurations from the generated FM that are valid with respect to the input configurations. The second one focuses on the difference between the configurations of the generated FM and the input configurations.

Janota *et al.* [115] developed an interactive editor to guide users in synthesizing an FM. It presents to the user the possible edit operations that respect the input proposition formula. Each time the user takes a decision, the next possible operations are computed. This allows to produce a high quality hierarchy for the FM while ensuring its consistency with the formula. The editor relies on binary decision diagrams to query the formula for possible edit operations.

3.2.3 Reverse Engineering Feature Models

Considering a broader view, reverse engineering techniques have been proposed to extract FMs from various artefacts (*e.g.* product descriptions [37, 80, 89, 155], architectural information [20] or source code [139]).

Davril *et al.* [80] present a fully automated approach, based on prior work [99], for constructing FMs from publicly available product descriptions found in online product repositories and marketing websites such as SoftPedia and CNET. The proposal is evaluated in the anti-virus domain. The product descriptions on such sites are generally incomplete, lack of a unifying structure, apart from the product header, and propose informal descriptions using uncontrolled natural language. PCMs also aim to describe products. Contrary to informal product descriptions considered in [80], PCMs are semi-structured. We think there is an opportunity to exploit this structure to guide FM synthesis.

Nadi *et al.* developed a comprehensive infrastructure to automatically extract configuration constraints from C code [139]. In the work of Acher *et al.*, architectural knowledge, plugins dependencies and the slicing operator are combined to obtain an exploitable and maintainable FM [20]. In particular the feature hierarchy reflects the hierarchical structure of the system. Ryssel *et al.* developed methods based on Formal Concept Analysis and analyzed incidence matrices containing matching relations [155].

Yi *et al.* [191] propose to apply support vector machine and genetic techniques to mine binary constraints (requires and excludes) from Wikipedia. This scenario is particularly relevant when dealing with *incomplete* dependencies. They evaluated their approach on two FMs of SPLOT.

Vacchi *et al.* [177] propose an approach to automatically infer a feature model from a collection of already implemented language components. The goal is to automate the configuration of families of (domain-specific) programming languages. The evaluation showed that a substantial effort is needed to incorporate domain or ontological knowledge. Bagheri *et al.* [37] propose a collaborative process to mine and organize features using a combination of natural language processing techniques and Wordnet. Ferrari *et al.* [89] apply natural language processing techniques to mine commonalities and variabilities from brochures.

Alves *et al.* [28], Niu *et al.* [141], Weston *et al.* [187], and Chen *et al.* [58] applied information retrieval techniques to abstract requirements from existing specifications, typically expressed in natural language. These works do not consider precise logical dependencies and solely focus on ontological semantics. As a result users have to manually set the variability information. Moreover a risk is to build an FM in contradiction with the actual dependencies of a system.

The techniques exposed in this section are considering other kinds of inputs than PCMs. A notable exception is the work of Acher *et al.* who propose a semi-automated procedure to support

the transition from product descriptions expressed in a tabular format to FMs [21]. Similar to our approach in Part II, the procedure uses a metamodel to normalize the PCM. The authors created a language called VariCell that allows to specify directives and parameters for the transformation of a CSV file into this metamodel. In particular, the user can define the semantics of the content of the cells regarding variability information (*e.g.* the keyword "optional" defines an optional feature). Then, the procedure consists in deriving an FM for each product of the PCM and finally merge all these PCMs into a single one. This work acts as a preliminary step towards the techniques exposed in this thesis.

3.2.4 Tool support

There are numerous existing academic or industrial tools for specifying and reasoning about FMs. *FeatureIDE* [173, 174] is an Eclipse-based IDE that supports all phases of feature-oriented software development for the development of product lines (domain analysis, domain implementation, requirements analysis and software generation). *FAMA (Feature Model Analyser)* [43] is a framework for the automated analysis of FMs integrating some of the most commonly used logic representations and solvers. SPLOT [131] provides a Web-based environment for editing and configuring FMs. S2T2 [144] is a tool for the configuration of large FMs. Weston et al. [187] provided a tool framework *ArborCraft* which automatically processes natural-language requirements documents into a candidate FM, which can be refined by the requirements engineers. Commercial solutions (*pure::variants* [148] and *Gears* [122]) also provide a comprehensive support for product lines (from FMs to model/source code derivation).

3.3 Conclusion

As PCMs are views on product lines, feature modeling is a good candidate for the formalization of PCMs. Yet the design of an FM is an error-prone and tedious task. Numerous works address the synthesis or reverse engineering of FMs from various artifacts. Table 3.2 is a PCM that gives an overview of the state of the art synthesis techniques that produce FMs. The products are the techniques and the features are the input artifacts as well as the precision, the maximality and quality of the resulting FM. From this table and previous discussions, we observe two main limitations of current practice.

A first limitation is the lack of support for synthesizing FMs that exactly represents the input artifacts and exhibit a meaningful hierarchy. In other words, prior works often foster configuration semantics over ontological semantics or vice versa. In Chapter 7, we develop heuristics and an interactive environment for guiding the construction of the hierarchy of the FM. Our techniques improve the ontological semantics of the resulting FM while preserving a sound and complete synthesis.

A second limitation is the focus on Boolean FMs. The formalization of PCMs with Boolean FMs is unlikely due to the presence of numerical and textual values. As we have seen in Section 3.1.3, attributed FMs address the problem by capturing these kinds of information in attributes. Despite the availability of some tools and languages supporting attributes [39, 44, 60, 84], no prior work consider the synthesis of attributed FMs. In Chapter 8, we present the first algorithm for synthesizing attributed FMs. We consider a special class of PCMs as input that we call configuration matrices. Intuitively, these are PCMs that are well structured and defined in order to easily derive the underlying configuration semantics.

Overall, the only work on the synthesis of FMs from PCMs is [21] and act as a basis for this thesis. Our challenge is to investigate the possible semantic and syntactic gap between PCMs and FMs and develop FM synthesis techniques for this new kind of input.

Technique	Input	Precision	Ensure Maximality	Basis for addressing quality
Acher <i>et al.</i> [18]	propositional formula	exact	✓	parts of the desired FM provided by the user
Czarnecki <i>et al.</i> [78]	propositional formula	complete	✓	outputs the set of all possible hierarchies
She <i>et al.</i> [165, 166]	propositional formula	exact	✓	rank parents based on textual description of features
Andersen <i>et al.</i> [29]	propositional formula	exact	✓	hierarchy selection is not addressed
Janota <i>et al.</i> [115]	propositional formula	complete	✗	interactive editor
Lopez <i>et al.</i> [125, 126]	set of configurations	arbitrary	✓	evolutionary algorithm without control of the quality of the hierarchy or feature groups
Haslinger <i>et al.</i> [100, 101]	set of configurations	complete	✗	logical heuristic
Davril <i>et al.</i> [80]	textual product descriptions	arbitrary	✓	text-mining and co-occurrences of features
Ryssel <i>et al.</i> [155]	incidence matrix	exact	✓	logical heuristic
Bagheri <i>et al.</i> [37]	textual documentation	arbitrary	✗	graphical visualization of the semantical similarity of features
Acher <i>et al.</i> [20]	software artefacts	exact	✓	relations expressed in software artefacts
Vacchi <i>et al.</i> [177]	language components	sound	✓	semantic network built by domain expert
Alves <i>et al.</i> [28]	natural language requirements	arbitrary	✓	semantical similarity between requirements
Weston <i>et al.</i> [187]	natural language requirements	arbitrary	✓	semantical similarity between requirements
Chen <i>et al.</i> [58]	natural language requirements	arbitrary	✓	semantical relationships between requirements
Acher <i>et al.</i> [21]	PCM	exact	✓	heuristics and instructions provided by the user
Our synthesis algorithm (see Part III)	PCM, propositional formula, set of configurations	exact	✓	user input and both logical and ontological heuristics

Table 3.2: PCM of FM synthesis and reverse engineering techniques

Part II

OpenCompare: a Framework for Product Comparison Matrices

Chapter 4

A Model-Based Approach Driven By Data, Users and Services

"Welcome...to the desert of the real."

Morpheus

As we explained in Chapter 2, there is no existing formalism dedicated to PCMs. To address the problem, we consider the development of a model-based approach. With a model-based approach, we can precisely define the structure and semantics of a PCM with a metamodel. Moreover, a metamodel is appropriate for querying, reasoning or editing a model. We can also develop a set of transformations in order to derive PCM models from raw PCMs. In case the metamodel is not appropriate for a specific task, we can derive other formalisms such as ontologies, spreadsheets or other metamodels.

In this chapter, we first present the case study of Wikipedia which will be the center of the evaluation of our approach (see Section 4.1). Then, we describe three objectives of designing a model-based approach for PCMs (see Section 4.2). For each objective, we identify a related research question to evaluate the effectiveness of our approach. In Section 4.3, we highlight the challenges of developing a model-based approach in the context of PCMs. Finally, we present our methodology for addressing these challenges (see Section 4.4). It is based on an iterative process driven by data, end-users and services. This methodology will be used in both Chapter 5 and Chapter 6.

4.1 The Wikipedia Case Study

Wikipedia is an online encyclopedia based on the MediaWiki wiki engine. Wikipedia is separated by languages. The English version reached a total of 5,000,000 articles on 1st November, 2015 which represents the largest corpus of articles in Wikipedia. We estimate that this version contains at least 1,500,000 tables. During our various experiments, we observed hundreds of PCMs. Therefore, Wikipedia represents a large dataset of publicly available PCMs. For example, Figure 4.1 shows a PCM comparing Web conferencing software.

The basis of Wikipedia is to allow anyone to contribute to the encyclopedia. For that purpose, it offers a built-in textual editor for modifying the so called *wikitext* which is the internal representation of an article. The wikitext syntax is derived from markdown languages and aim to be simple to read and edit. Yet, when it comes to the creation of tables, the syntax quickly shows its limits. For example, Figure 4.2 shows an excerpt of the wikitext code extracted from the PCM of Figure 4.1. The documentation of MediaWiki even states that "as a general rule, it is best to avoid using a table unless you need one. Table markup often complicates page editing" [130].

Concerning tables, the capabilities of the language are very limited and close to what we can observe in HTML or CSV. It is based on 3 main operators in order to create new tables (`{|}`), rows



Program	License	Capacity	Linux 	Mac OS X 	Microsoft Windows	Audio Support 	Video Quality
Adobe Connect	Proprietary	1-1500 (80 000 w/webcast)	✓	✓	✓	✓ ^[note 1]	VGA, HQ, HD ^[1] ^[not in citation given]
AT&T Connect	Proprietary	1-1500	✓ ^[note 4]	✓	✓	✓	HQ
AnyMeeting	Proprietary	1-200	✗ ^[4]	✓	✓	✓	HQ
Attentiv	Proprietary	1-1000	✓ ^[6]	✓	✓	✗	✗
BigBlueButton	LGPL, GPL	1-80 ^[8] ^[self-published source]	✓	✓	✓	✓	VGA,HQ

Figure 4.1: Example of a PCM in Wikipedia [65]

```
{| center;" class="wikitable sortable"
|-
! Program
! License
! Simultaneous User Capacity
! Linux
[[Image:Tux.svg|25px|Linux]]
! Mac OS X
...
! Recording capabilities
|-
| {{rh}} | [http://www...]
| [[Proprietary software license|Proprietary]]
| {{Sort|0000500|1–1500 (80,000 w/webcast)}}
| {{Yes|?}}
|...
| {{Yes|?}}<ref name="ReferenceA">
Supports two-way ... integration</ref>
| {{Yes|}}VGA, HQ, HD<ref>[http://www.ad... ]
Retrieved on 2014-02-27.</ref>
| {{Yes|?}}
...
| {{No|X}}
|-
```

Figure 4.2: Code snippet in wikitext of the table of Figure 4.1

(|-) and cells (| or !). In addition, a contributor can make the distinction between header cells (!) and data cells (|).

The syntax is also complemented with a set of references and templates that will add some layout features (colored cells, logos, etc.) For instance the cell "`{{Yes|?}}`" is part of a template that will color the cell in green and display the content "?".

We observe that there is no concept of a column and no relationship between cells that belong to one column. For instance, the second cell of a given row is not bound to the second cell of each other rows. They are only part of the same column because of a fortunate layout side effect. Similarly, the wikitext syntax allows to define a cell as being a header without any constraint on its position. For a PCM, this induces a gap between the concrete source code representation of a PCM, and the human interpretation of this PCM. While one considers the matricial representation that characterizes PCMs as a table, he or she manually interprets the content as products, features, and interpret other cells as cross-references between products and the corresponding values for their features. The focus of wikitext is thus on the layout instead of the semantics.

To overcome these limitations, many transformations from alternative formats (CSV, Excel, etc.) to wikitext have been created [188]. Though easier to edit, spreadsheets suffer from the same limitations while expressing product \times feature relationships. Cells are associated to a column and a row but they must be manually interpreted as features, products or data.

Another solution is the use of the visual editor of MediaWiki which was released in July, 2015 [82]. It offers a bi-directionnal synchronization between the wikitext of an article and a visual and editable representation of the rendered page. Thanks to this editor, the edition of table is significantly simplified. However, the support for PCMs is limited to the ability to sort columns. To our knowledge, there is no plan for a dedicated support of PCMs. Yet during informal discussions with active contributors of Wikipedia, we observed a vivid interest in our techniques and the development of a dedicated solution for the encyclopedia. This further motivates the formalization of PCMs.

Sannier *et al.* observed in detail 50 PCMs from Wikipedia [156]. From their product line point of view, they extracted a set of variability patterns that could possibly encode the information contained in PCMs. This work is the basis for the formalism that we are proposing in this chapter.

Overall, Wikipedia represents a good case study for the problem of formalizing PCMs. The universality of the encyclopedia and the numerous contributors ensure a diversity of domains and practices in the definition of PCMs. The millions of existing tables potentially form a large dataset of PCMs which contributes to the generalization of our techniques. Moreover, the dataset is publicly available which ease the reproduction of our results. Finally, the syntax used for editing PCMs in Wikipedia is similar to other languages such as HTML or CSV which are also widely used for the same purpose.

4.2 Problem Statement

In this part of the thesis, we aim to elaborate a metamodel to describe PCMs and a transformation between raw PCMs to PCM models. We identify 3 objectives to the development of this model-based approach.

A first objective is that the metamodel should precisely represent the domain of PCMs and be able to formalize existing examples. The large diversity and number of PCMs make the formalization process error-prone and time consuming. A second objective is to automate the formalization process in order to decrease user effort and improve quality of PCM models. Finally, a metamodel is a common basis for the derivation of analyses and services. A third objective of our approach is to ease the development of services dedicated to PCMs. Moreover, our metamodel should improve the effectiveness and precision of automated analyses. To evaluate these objectives, we identify the following research questions:

RQ1: Is our metamodel complete and relevant to the formalization of PCMs?

RQ2: What is the precision of our transformation of raw PCMs to PCM models?

RQ3: Is our metamodel suited for engineering automated analyses and services dedicated to PCMs?

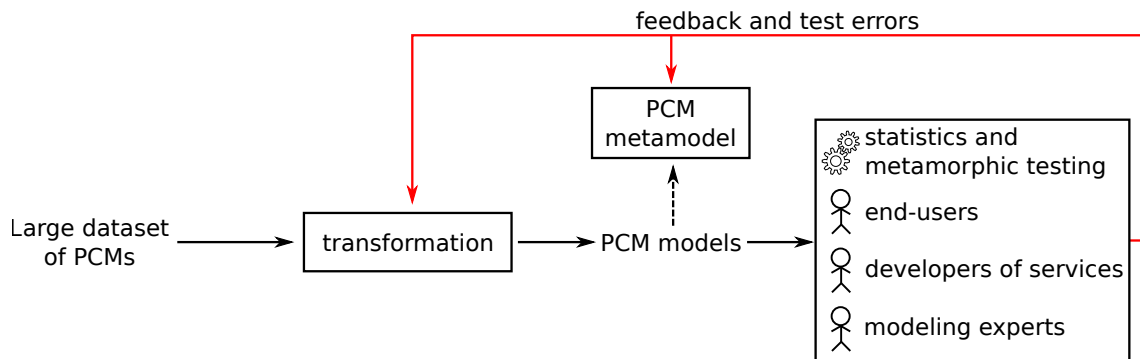

Figure 4.3: Iterative process for the elaboration of a model-based approach for PCMs

With this last question we want to evaluate the success factors (*e.g.* learnability, usability or development costs) of the use of our approach [105, 114]. We base this evaluation on the feedback gathered during the numerous developments that we performed during the elaboration of our approach. These developments will be detailed in Chapters 5 and 6.

4.3 Challenges

In Section 2.6, we present various techniques to design a metamodel. They mainly rely on domain experts to define the concepts and their relations. In our context, there is no identified expert but rather a multitude of contributors creating PCMs without following general guidelines. Neither does a common format exist on which we can rely to base our metamodel (see Chapter 2). Therefore, there is a lack of oracle to assess that our formalization is correct.

In addition, our case study shows that millions of tables and thus potential PCMs exist on Wikipedia. Yet, it represents a small part of the Web which contains at least billions of tables [51]. Therefore, manually building an oracle seems unrealistic. It would be a very time-consuming task and we have no way to ensure that the oracle covers all the complexity and diversity of PCMs.

The lack of oracle challenges the elaboration and evaluation of a model-based approach for PCMs. To build our approach, we need to manually explore representative examples of PCMs. The techniques presented in Section 2.6 use examples to build metamodels but they do not explain how to choose these examples. A first challenge is to choose a set of PCMs that is interesting for the design of our metamodel and small enough to be manageable by a human. A second challenge is to test our approach on numerous PCMs in order to assess its precision and robustness. A third challenge is to design a metamodel that both accurately represents the domain of PCMs and can be the basis for the development of services.

4.4 An Iterative Process Driven by Data, Users and Services

To address the challenges described previously, we design our model-based approach by following an iterative process (see Figure 4.3). The idea is to automatically process a large dataset of PCMs with our transformation. Then, we evaluate the obtained PCM models with

- automated analyses on the PCM models
- manual checking by end-users
- feedback from developers of services based on the metamodel.

Based on this evaluation, we refine our approach. Finally, we iterate our process. The design of our metamodel and our transformation is thus driven by data, end-users and services. Another important actor of our process is the modeling experts in charge of the design of the approach. Their role consists in continuously improving the metamodel and transformation based on their

evaluation. They ensures the idea behind the metamodel is preserved throughout the iterations. In the case of PCMs, we ensure that the metamodel reflects the idea that a PCM is a representation of a product line. We also check that we do not get influenced too much by the dataset of PCMs that we analyze. Otherwise, we could introduce too much complexity in the metamodel in order to represent the dataset.

In Chapters 5 and 6, we elaborate two versions of our approach based on this iterative process. The resulting metamodels and transformations as well as their evaluation are presented in details in these chapters.

4.4.1 Initialization

To initiate our process, we need to build a first version of the metamodel and transformation. This step requires a manual analysis of examples of PCMs. The base of our analysis is the study realized by Sannier *et al.* [156]. They studied more than 300 PCMs from Wikipedia. Moreover, they adopted a product line point of view that we also find in our approach. We also perform a detailed analysis of tens of PCMs also from Wikipedia.

4.4.2 Evaluating Our Metamodel and Transformation

Once we have a metamodel and a transformation, we must evaluate them according to our 3 research questions. For that purpose, we have 3 sources of feedback: data, end-users and services.

Data. To gather feedback from the data, we perform two analyses. First, we compute statistics on all the PCM models that we extract from raw PCMs. In particular, we analyze the usage of concepts in our metamodel. If a concept is never used, it may indicate that the concept is not relevant for PCMs can be removed from the metamodel. Another possibility is the presence of a bug in our transformation that fails to extract such concept from our dataset of PCMs. If a concept is very often used, we may want to separate it in sub-concepts in order to increase the expressiveness and precision of our metamodel.

The second analysis consists in testing the robustness and precision of our transformation by using *metamorphic testing* [59]. Metamorphic testing uses properties of the software under testing to assess its correctness without relying on an oracle. In our case, we exploit the property that given a PCM model m and a format f , the following equality holds: $\text{import}_f(\text{export}_f(m)) = m$. In other words, exporting a PCM in a particular format (*e.g.* CSV, HTML or wikitext) and importing it back should result in the exact same PCM. In Chapter 6, we implemented 4 couples of importers and exporters: HTML, CSV, wikitext and JSON. Thanks to metamorphic testing, we can test our importing and exporting capabilities on millions of PCMs from Wikipedia. Therefore, we can automatically explore a large diversity of PCMs. Moreover, the failing metamorphic tests give us important feedback for improving our transformation of raw PCMs to PCM models.

Users. To gather feedback from end-users, we use an editor dedicated to PCMs and built on top of our metamodel. The editor allows to present the concrete syntax of the PCM models to the evaluator instead of directly presenting the metamodel or a model in graph notation (*e.g.* the object diagram notation of UML). The main advantage of using the concrete syntax is to display a familiar view of a PCM. As such, there is no need for modeling knowledge to check that our formalization is correct. The participants evaluate the metamodel as end-users.

Services. To gather feedback from the developers of services, we conduct several experiments in order to create services based on our metamodel (see Chapters 5 and 6 for more details). The development of the editor used by end-users is part of these experiments. We developed also other services such as a comparator, a configuration and visualizations. By having a significant number of services and developers involved we can gather valuable feedback on the usability, expressiveness and learnability of the metamodel. This allows us to check that our approach is suited for the development of services.

4.4.3 Bootstrapping

Based on the feedback gathered during the evaluation of our approach, we refine our metamodel and transformation. Then, we can bootstrap our iterative process by executing the new version of the transformation in order to get a new set of PCM models to evaluate. At each iteration, we improve our formalization technique. As a consequence, we improve the quality of the generated PCM models. As we base our evaluation on these models, we can gather new feedback. This creates a virtuous circle.

4.5 Conclusion

To address the formalization of PCMs, we adopt a model-based approach. It consists in creating a metamodel for PCMs and a transformation from raw PCMs to PCM models. The lack of identified expert and existing oracle challenges the elaboration and evaluation of our approach. Moreover, the large number and diversity of existing PCMs hinders the manual design of an oracle. To address these challenges, we propose an iterative process driven by data, end-users and services. Wikipedia contains numerous PCMs created by various contributors on multiple domains. We think that it constitutes a representative dataset of PCMs on which we can base our evaluation.

In Chapter 5, we present the result of a first batch of iterations of our process. It results in a metamodel and a transformation that allows a precise formalization of PCMs. Yet, the feedback gathered during the development of multiple services shows that the metamodel is not satisfactory for addressing all requirements and tasks (related to *interoperability*, *edition*, and *manipulation*). In Chapter 6, we address this problem by separating the different concerns of our metamodel into multiple metamodels. We present the result of a second of iteration in which we consider the comprehensive dataset of Wikipedia PCMs for our evaluation.

Chapter 5

Automating the Formalization of PCMs

"Neo, sooner or later you're going to realize just as I did that there's a difference between knowing the path and walking the path."

Morpheus

In this chapter, we explore a first approach to address the problem of formalizing PCMs. Figure 5.1 presents an overview of our automated model-based approach for formalizing PCMs. The central element of our approach is a metamodel defining the structure and semantics of a PCM (see ① of Figure 5.1 and Section 5.1). Based on this metamodel, we develop a transformation chain for automatically transforming raw PCMs into PCM models. It consists in three phases: parsing, processing and extracting information (see ②, ③, and ④ of Figure 5.1 and Section 5.2 for details). We empirically evaluate our approach according to the three research questions defined in Chapter 4. We base our evaluation on the analysis of 75 PCMs from Wikipedia by 20 participants (see Section 5.3). To support the different tasks of our evaluation, we developed a Web-based editor for PCMs. We also asked 20 Master students from the University of Rennes 1 to develop another editor and an API for the manipulation of PCMs (see ⑤ of Figure 5.1). These two development experiences are also part of our evaluation. Finally, we discuss threats to validity (see Section 5.4) and conclude the chapter (see Section 5.5).

5.1 The PCM Metamodel

Figure 5.2 presents the PCM metamodel obtained by following the iterative process described in Chapter 4. This metamodel describes both the structure and the semantics of the PCM domain. In this metamodel, PCMs are not individual matrices but a set of different matrices that contain cells. This separation usually happens when comparing a large set of products or features. In order to preserve readability, PCM writers can split the PCM content into several matrices. Cells can be of 3 types: *Header*, *ValuedCell*, and *Extra*. Header cells identify products or features.

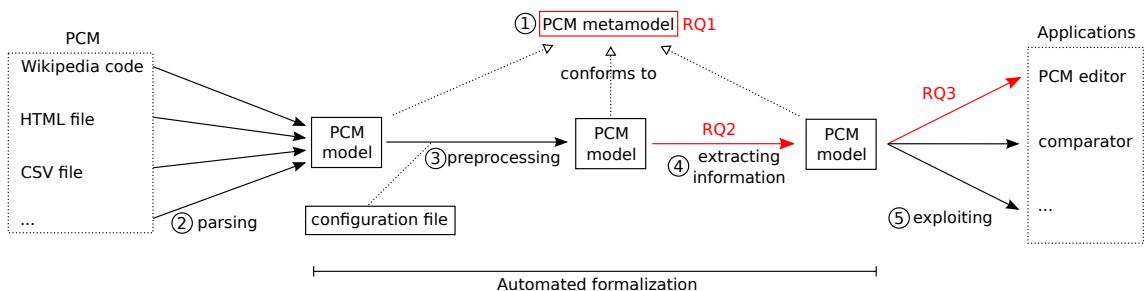

Figure 5.1: Global View of our Automated Formalization of PCMs

In our metamodel, the structure of the PCM is not led by rows or columns but with explicit concepts of products and features. These products (resp. features) can have a composite structure that is used when describing several levels of granularity for these products (resp. features) and which are usually represented by row or column spans.

In Excel or Wikipedia, cell values are associated to products and features because of their relative and fortunate positions. In our approach we have explicit associations between a cell and its related product and feature. In addition, we keep the syntactic layout with the row and column attributes in the *Cell* class.

On the semantics side, PCMs express commonalities and differences between products. As a consequence, formalizing such domains necessarily requires to introduce some concepts from the variability and product line engineering community but also to introduce new ones. We have two main concepts: the *Constraint* class that represents the interpretation of the information contained in a valued cell and the *Domain* class that defines the possible values for a feature. The interpretation of a valued cell is given according to different patterns and information types defined as sub-concepts of *Constraint* in the metamodel:

- Boolean: states that the feature is present or not
- Integer: integer numbers
- Double: real numbers
- VariabilityConceptRef: references a product or a feature
- Partial: states that the feature is partially or conditionally present
- Multiple (And, Or, Xor): composition of values constrained by a cardinality
- Unknown: states that the presence or absence of the feature is uncertain
- Empty: the cell is empty
- Inconsistent: the cell is inconsistent with the other cells bound to the same feature

The domain of a feature is represented as a set of *Simple* elements (*Boolean*, *Integer*, *Double* or *VariabilityConceptRef*) which defines the valid values for the cells that are related to this feature. The concept of domain allows us to detect invalid values and reason on discrete values such as features but also use the properties of boolean, integers and real values for ranking or sorting operations.

5.2 The Transformation Chain

Having a formalizing canvas with a metamodel is only one mean to a larger end. Formalizing PCMs in their whole diversity and heterogeneity requires a set of transformations steps. The first step is the parsing. It consists in extracting the PCM from its original artefact (*e.g.* MediaWiki code). The second step is the preprocessing. The objective is to obtain a matrix without missing cells or rowspan and colspan. Moreover, the preprocessing identifies which cells contain the variability information. The parsing and preprocessing steps aim to handle the complexity from the syntax.

The last step is the extraction of the variability information. This step aims to handle the complexity from the semantics. It consists in identifying and extracting from the cells, the variability patterns that we explained previously. The main challenge is to develop an extraction rule for each pattern that is able to process the content of cells expressed in natural language.

5.2.1 Parsing

PCMs are represented in various artefacts and languages. Before analyzing PCMs, we need to represent their matrices in a common form. Our PCM metamodel provide this common form as it can represent PCMs in a purely syntactic way. In this step, we only use the following classes from our metamodel: *PCM*, *Matrix*, *Cell* and the different sub-classes of *Cell*. We developed a parser

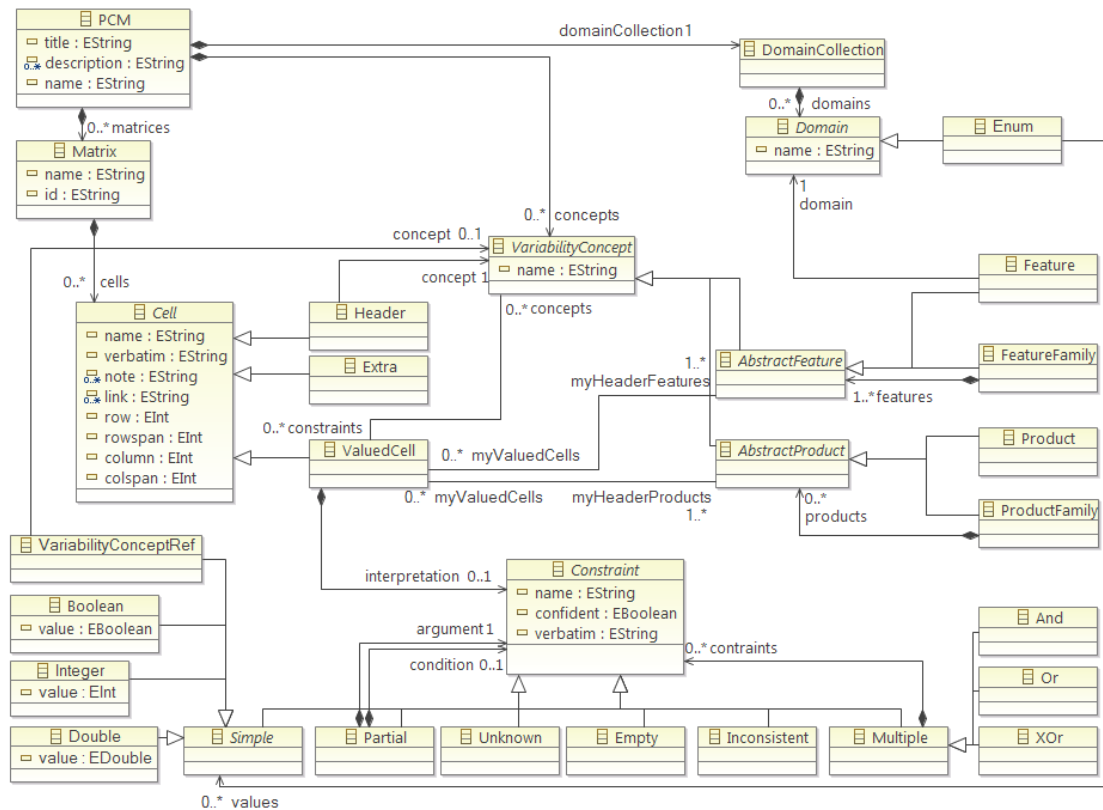

Figure 5.2: The PCM Metamodel

for CSV files and a parser for MediaWiki code using the Sweble Library¹. We used this parser to extract 75 PCMs from Wikipedia (see Section 7.5). This step is fully automated.

Our metamodel provides a common format from which we can base the subsequent steps of our formalization process. This allows us to reuse our approach for all the artefacts that can be encoded as a matrix containing a set of cells.

5.2.2 Preprocessing

As the concept of columns is not always present (*e.g.* a CSV file is a list of rows) and rowspan and colspan may create rows or columns that have different lengths, PCMs may not have rectangular matrices. Therefore, a first step toward the formalization of PCMs is to normalize their matrices. The preprocessing phase adds missing cells and duplicate cells with rowspan and colspan. It results in a simple and plain matrix.

After this normalization, the preprocessing phase identifies the types of the cells. There are 3 types of cells in our metamodel (see Figure 5.2): *Header*, *ValuedCell* and *Extra*. By default, the top left cell is set as *Extra*, the first row and column is set as *Header* and the remaining cells are *ValuedCell*. A specific mapping can be provided through a configuration file in order to support the various PCM forms. For example, we can ignore some rows or columns that will be represented as *Extra* cells in the model or specify that there is more than 1 row of headers.

This step can be either semi-automated or fully automated depending on the manual input provided by the configuration file. In our evaluation, we used configuration files to guide the preprocessing (see Section 5.3.1).

¹<http://sweble.org/>

5.2.3 Extracting Information

After the preprocessing phase, the problems related with the syntactic structure of a PCM are resolved. The last step is to interpret the cells in order to extract the variability information that a PCM contains. In this phase, we progressively enrich the model with new information.

Similarly to the preprocessing phase, this step can be either semi-automated or fully automated. In our evaluation, it is important to mention that we did not use configuration files for this particular task. It was performed in a fully automated way.

Extracting Variability Concepts from Headers. The first information that we extract is the variability concepts from the headers that were specified in the preprocessing phase. By default, the headers in the top rows are considered as features and the headers in the left columns are considered as products. Here again, a different mapping can be provided through a configuration file in order to specify for each header if it represents a feature or a product. At the end of this extraction, the model is enriched with *Feature*, *FeatureFamily*, *Product* and *ProductFamily* elements and the *Header* elements are binded to their respecting variability concept through the *concept* association.

Interpreting Cells. After this extraction, we interpret the cells' contents in order to disambiguate them and extract variability information. Each cell is interpreted as a constraint over the features and the products of the PCM. Only cells of type *ValuedCell* need an interpretation as headers are labels of features or products and extra cells are ignored. This interpretation is led by a list of rules that are either defined by default in our transformation or specified by the user through the configuration file.

The interpretation rules are composed of 4 elements: a list of headers, a type of constraint, a regular expression and parameters. The list of headers allows to restrict the rule to specific rows or columns in the PCM. The type corresponds to one of the *Constraint* sub-classes in the metamodel (see Figure 5.2) that will be instantiated if the rule is applied. The regular expression defines in which cases the rule should be applied. If it matches the cell content, the rule is applied and the potential groups in the regular expression can be used to separate the cell content in sub-constraints. Finally, the parameters are here to provide additional information for the creation of a constraint. For example, in a rule of type *Partial*, we can specify how the groups of the regular expression will be mapped to the *argument* and *condition*.

For each cell, we iterate over the list of interpretation rules. If a rule matches, it creates its corresponding constraint and the cell is binded to its constraint through the *interpretation* association of the class *ValuedCell*. If the matching rule separates the content in sub-constraints, we recursively interpret them with the same list of rules. If no rule matches, the constraint is not created. Therefore, a PCM editor could detect afterwards all the cells that are not interpreted and raise a warning.

Extracting Variability Concepts from Interpreted Cells. Among the constraints that were created during the interpretation, *VariabilityConceptRef* constraints represent references to products or features. The next step of the formalization is to bind these references to the corresponding products or features through their *concept* association. However, such constraint may reference a feature that is not declared in the headers. In this case, we need to create this implicit feature first.

Extracting Feature Domains. The last step of the formalization is to determine the domains of the previously extracted features. In our metamodel, a feature domain is an enumeration of *Simple* elements (see Figure 5.2). To determine the domains, we separate features in two categories: features that are defined in headers and features that are implicitly defined in valued cells. For each feature, we first collect all the *Simple* elements contained in the interpretation of the cells associated to the feature. For implicit features, an empty domain is created as the PCM only deals with their presence.

For features in headers, we group their domain elements according to their types (*Integer* and *Double* elements are grouped together as they both represent numbers). We select the group with the maximum size as it represents, potentially, the most correct type of values regarding the feature.

If it is a boolean or number group, we directly add its values in the domain of the feature. However, if it is a group with *VariabilityConceptRef* elements, we perform hierarchical clustering on it to remove rare values. This selection of valid values for a feature, allow to highlight the cells that are possibility inconsistent with respect to the majority.

5.3 Evaluation

In this section, we evaluate our solution for automatically formalizing PCMs with respect to the three research questions of Chapter 4. First, we present the dataset and conditions of our experiments for RQ1 and RQ2. Then, we discuss our results for all the research questions. Our dataset, empirical results, and the set of tools used in the evaluation are available online: <http://tinyurl.com/PCMFormalization>.

5.3.1 Experimental Settings for RQ1 and RQ2

Dataset. We selected 75 PCMs from Wikipedia. Though most of them are related to software (audio player software, browser synchronizers, application launchers, disc images, etc) our sample also covers a very large spectrum of domains. This includes domains such as photography and technology (digital SLRs, embedded computer systems), sport and hobbies (ski resorts, video games), economy (tax preparation, enterprise bookmarking), electronics and hardware (fanless switches, chipsets, radio modules), history (world war II), healthcare (dental practice management, dosimeters) among others. The 75 PCMs are made of a total of 211 matrices from various sizes, going from 2 to 241 rows, and 3 to 51 columns for a total of 47267 cells.

Formalization of PCMs. Following our automated process depicted by Figure 5.1, the 75 selected PCMs were first parsed into models that conform our PCM metamodel described in Section 5.1. Then, we manually configured the preprocessing step in order to specify the headers and *Extra* cells of each matrix. Among the 47267 cells of our dataset, 6800 (14.39%) are *Headers*, describing either products or features. Another 992 (2.10%) are *Extra* cells that do not carry any valuable information. Finally, 39475 (83.51%) cells are considered as *ValuedCells*. Finally, we executed the extracting information step without configuration and only with default interpretation rules.

Metrics. To answer RQ1, we measure the distribution of the concepts of the metamodel. We also gather informal feedback on the relevance of each concept and check if we missed concepts during the design of the metamodel. To answer RQ2, we measure, for each concept, the precision of our transformation chain.

Participants. To evaluate our research questions, each PCM was evaluated by at least one person among a panel of 20 persons (mainly researchers and engineers) that were not aware of our work. They never saw the metamodel, neither its tooling before the experiment.

Evaluation Sessions. We organized two evaluation sessions. During these sessions we explained to the evaluators that they will check the formalization of cells of a set of PCMs. We provided a tutorial describing the tool they will have to use, as well as the concepts they were about to evaluate and related illustrative examples.

The checking process consists of looking at each cell of a PCM and its associated formalization, *i.e.* the class in the metamodel. The evaluators check if the formalization corresponds to their own interpretation of the cell. For each cell, they can:

- validate the formalization
- propose another formalization using the concepts of the metamodel

- propose a new concept
- claim that there is no possible interpretation
- declare that he/she does not know at all how to analyze the cell

In addition to the validation task using the interface, evaluators were allowed to leave comments on an additional menu and to exchange with us. The feedback gathered during the different sessions gives us the metrics to answer our research questions.

As the evaluation tool is a web application, the participants were also able to continue the evaluation on their own at a different time, though they were encouraged to complete the PCM evaluation before submitting the results. Depending of the size of the PCM (number of matrices, complexity of cells, syntactic wellformedness), evaluating a PCM takes between 5 to 20 minutes.

Evaluation Scenario. The tool proposes a randomly chosen PCM to ensure the global coverage of the 75 PCMs. Consequently, during the group session, no evaluator has the same PCM to evaluate.

Right clicking on a cell displays options to validate or not its proposed formalization. To avoid painful individual validation, evaluators are allowed to make multiple selections for collective validation or corrections. Once evaluated, the cells are colored in green, but it is still possible to modify the evaluation. At the end, they submit their evaluation to a database and possibly start again a new evaluation.

Evaluated Cells. Among the 39475 cells of the 75 PCMs, 20.83% were ignored (the evaluator declared that he/she does not know how to analyze the cell) or omitted (no results) by our evaluators. 3.02% were subject to conflicts between evaluators (difference in the correction). As a consequence, 30061 cells are evaluated and present analyzable results. In the following, we will answer the research questions according to these evaluated cells.

5.3.2 RQ1: Is our metamodel complete and relevant to the formalization of PCMs?

In this section, we aim at answering our first research question (RQ1), which is related to the definition of our metamodel, its soundness and completeness. We define soundness as the effective use of the different metamodel concepts. We evaluate it with the number of occurrences of each concept of the metamodel. We define completeness as the fact that there is no missing important concepts in the metamodel. We evaluate it with the analysis of new concepts that our evaluators proposed during the evaluation.

Use of the Metamodel Concepts. During the experiment, 95.72% of the evaluated cells were validated or corrected with concepts of the metamodel. Only 4.28% of cells were not validated and the evaluators proposed a new concept. In Table 5.1, we present the use of each metamodel concept after the correction by our evaluators. In this table *Multiple* represents the constraints that were not specialized as *And*, *Or* or *XOr*.

First, we observe that all the concepts are used in our metamodel. The most used concepts are *Boolean*, *VariabilityConceptRef* and *Unknown*. Some concepts are rarely represented such as *Inconsistent* or *XOr* but our evaluators considered them as important for some cells. Yet, we still need to know the quality of the proposed concepts in the metamodel as well as the quality of our classification that we will detail in the following.

New Concepts. As stated previously, 4,28% of the cells were not validated by our evaluators and were corrected with a new concept. The rest of the cells were either validated or corrected with elements of the metamodel. We manually analyzed the new concepts and cluster the answers to form a new set of concepts. We provide the following observations. The very large majority of new concepts occur less than 20 times. A lot of provided concepts are in fact noisy and unexploitable

Table 5.1: Use of the metamodel concepts

Boolean	43.96%
VariabilityConceptRef	20.21%
Unknown	12.25%
Empty	8.62%
And	8.04%
Integer	3.20%
Partial	2.69%
Double	0.64%
Or	0.29%
Inconsistent	0.07%
XOr	0.02%
Multiple	0.01%

elements as some evaluators provided a concept that is a variant (or a composition) of one already existing concept.

Three new concepts are clearly emerging with more than 200 occurrences: dates, dimensions - units and versions. Dimensions and units of measure are two concepts that can overlap from time to time. Dates and versions are easier to distinguish though versions can be tagged using dates.

Our classification considers dates as integer numbers, and variability concepts when the date description expresses multiple concepts such as months, days, or trimesters. Our evaluators consider that dates deserve a dedicated concept that allow to handle such expanded expressions. These 3 extensions can be easily applied in our metamodel as they will be considered as specializations of the "Simple" metaclass.

Composing Concepts and Wellformedness. For the sake of concision, PCM authors may also mix different information such as versions and release dates in the same cell. If the distinction between multiple concepts and their interpretation requires little effort for a human analyst, it requires a specific operation from an automatic point of view. Our approach promotes separation of concerns, which can be translated in our example as creating two columns: one for the version and one for the release date.

"Multiple" Specialization. While exchanging with our evaluators, one difficulty that emerged was related to the semantics of the *Multiple* cell that expresses a composition with an AND, OR or XOR operator. Their semantics are simple but not intuitive and hard to determine at the PCM level. These operators are basic operators from a variability modeling point of view. They represent important actors for configuration and for managing combination issues. Yet, their semantics are still to determine from a PCM perspective.

Answer to RQ1. Regarding our research question, our metamodel proposes a set of necessary concepts that will have to be complemented by the three new concepts that have emerged. However, the semantics of the composition of Multiple values with AND, OR, and XOR have to be clarified.

5.3.3 RQ2: What is the precision of our transformation of raw PCMs to PCM models?

In this section, we aim at answering our second research question (RQ2), which is related to the degree and the quality of the automation of the transformation toward a PCM model. We will here evaluate the precision of our automated classification with respect to the empirical evaluation of our 20 evaluators and investigate on the errors made by the classifier. The precision will be the ratio of valid cells among all evaluated cells.

Table 5.2: Precision of our automated techniques in the evaluation of 75 PCMs

(a) Precision by concept		(b) Distribution of the precision	
Boolean	99.83%	Precision	Proportion of PCMs
Integer	79.62%	0-9%	1.33%
Double	45.21%	10-19%	0%
VariabilityConceptRef	86.25%	20-29%	0%
Partial	82.75%	30-39%	1.33%
Unknown	99.62%	40-49%	0%
Empty	91.37%	50-59%	4.0%
Inconsistent	N/A	60-69%	0%
And	87.07%	70-79%	8.0%
Or	91.38%	80-89%	13.33%
XOr	N/A	90-99%	45.33%
Total	93.11%	100%	26.67%

Global Results. Table 5.2 detail the data collected during the experiment. Table 5.1 gives the distribution of the concepts in the metamodel. Table 5.2a gives the precision of our transformation chain for each concept of the metamodel. Table 5.2b completes this information with the distribution of the precision. The left column indicates a range of precision of our technique. The right column gives the percentage of PCMs that are processed with a precision within that range.

We note that in Table 5.2a, the precisions of *Inconsistent* and *XOr* concepts are not available as they are not generated by our default interpretation rules. Our automated approach has been evaluated with a global precision of 93.11%, with different precision depending of the concept (see Table 5.2a). If we consider that the cells corrected with new concepts are not related to the precision of our automated techniques, then the precision reaches 97.27%. Table 5.2b shows that our approach can process the large majority of PCMs in our dataset with a precision of at least 80%.

Quality of the Transformation for PCMs. Table 5.2a shows that our interpretation rules are evenly precise except for the *Double* concept. This is due to the ambiguity of the interpretation of numbers which makes difficult the development of such rules. In contrast, we note that *Boolean* and *Unknown* interpretation rules have almost 100% of precision.

Table 5.2b provides a distribution of errors within PCMs. The objective is to know if our errors are very localized or scattered all along the PCMs. We note that our techniques reach more than 70% of precision in the large majority of PCMs.

Formalization Errors. Though the formalization step works well for correctly formed data, it is much less evident for complex data such as partial and multiple answers. If we consider the errors from the classification, we observe that they arise from 4 main areas.

- **Overlapping Concepts.** One way of precising information within a cell is to provide extra information between parentheses. For example, in the column *Capacity* of Figure 4.1, the first cell indicates that the capacity reaches 80,000 when using webcast. However, this pattern is also often used to express constraints or partial answers. As a consequence, we observe the same data pattern for two different concepts, and it still requires a human analysis to determine the correct concept among the two.
- **Missing Concepts.** The lack of certain concepts and their related interpretation rules have decreased the precision of our automated transformation.
- **Missing Interpretation Rules.** We may not have been able to have sufficient generic rules in the catalog.
- **Bad Rules.** We may have written incorrect interpretation rules that lead to bad classifications or misses.

Data Patterns and Specific Transformations. We recall that our transformation rules provide a catalog of generic data patterns but also allows the customization with PCM-specific data patterns. For instance, the Yes/No Boolean pattern can be replaced for a particular column with the pattern `X/""`, where the empty cell would stand for a "No" in one specific column.

For the experiment, we did not use specific patterns for our evaluation of 75 Wikipedia PCMs, considering a full degree of automation. Customizing with PCM-specific rules can be very useful for re-engineering specific PCMs we want to model as part of managing legacy data, though it lowers the automation degree but increases the precision. Further work is required to determine when specific rules can be generic enough to be incorporated into our generic catalog. Another further work will be to assess the necessary effort to provide these specific rules.

Answer to RQ2. Regarding a fully automated approach (excepting the very first preprocessing steps described in the protocol), our automated approach has been able to qualify our data set with a precision of 93.11%. Though the precision differs depending on the kind of information in the cell (as reported in table 5.2a), it is worth noticing that these results are obtained without any customization with PCM specific rules. Using such rules would have increased the precision. However, it requires the manual development of rules specific to a particular PCM or a particular domain. Thus, it decreases the degree of automation of our approach.

5.3.4 RQ3: Is our metamodel suited for engineering automated analyses and services dedicated to PCMs?

One of the objectives of our model-based approach is to ease the development of automated analyses and services in comparison to the use of classic applications supporting PCMs (e.g. spreadsheets, databases and websites).

To gather feedback on the development of services based on our metamodel, we performed two development experiments. The first one is the development of the editor used in our evaluation. The second development was performed by 20 Master students from the University of Rennes 1. The students were enrolled in the object-oriented design and development course. They can be considered as beginners in modeling. We asked them to also develop an editor and an API for the manipulation of PCMs.

Editing and Formalizing PCMs. A first application of our metamodel is to help the user in editing and formalizing a PCM. Our metamodel offers the concepts of *Feature*, *Product* and *Cell* which allow to focus on the edition of these concepts instead of the particularities of concrete formats (e.g. CSV, HTML or wikitext). For instance, the editor that we developed for our evaluation allows to check that the formalization of a PCM is as expected in order to ensure its further exploitation (see Figure 5.3, A). In case the formalization is incorrect, the user can directly edit the cell content or its interpretation on a familiar tabular view while conserving a model conformant to the PCM metamodel.

Providing Guidance. Guidance capabilities can be developed thanks to the *Inconsistent* concept in our metamodel and the computation of a domain for each feature (see Section 5.1 for further details). For example, an editor can warn the user that a cell content is considered as inconsistent or is not existing in its corresponding feature's domain (see orange cells in Figure 5.3, B). These warnings can be used by a user during the edition of a PCM from scratch or during a refactoring scenario to speed up the detection of incorrect cells. For instance, spell errors can be easily detected in a PCM without carefully reading thousands of cells.

Comparing Products. A first advantage of our metamodel over spreadsheet applications (e.g. Excel), databases or websites is that it contains explicit notions of products and features. With our metamodel, a comparator can directly reason in terms of these variability concepts. It does not have to care about the structural information (rows and columns) and thus it can reorganize products and features in order to visualize only the most important ones according to a user. The comparator can also use user-defined constraints (see Figure 5.3, C) to filter the products.

Contact	ExperimentTechnical specifications_0							Comments
feature	Video battery life	Video out	Screen size (in)	Screen type	Resolution (px)	Color depth (bpp)	Navigation	Speaker
iPod touch	6	Component, com...	3.5	TFT LCD	480 × 320 (4th g...	24 (4th gen.) 18 ...	Multi-touch scre...	Yes (ex. 1st gen.)
Gigabeat T-Series	5	Component, com...	2.4	TFT LCD	320 × 240	18	D-pad, 4 buttons	No
GF2X F-200	3.5	Component, com...	3.5	TFT LCD	320 × 240	16	8-way d-padtou...	Yes
iPod classic	6	Component, com...	2.5	TFT LCD	320 × 240	16	Click wheel, 1 ce...	Clicker only
Archos 405	5	Component, com...	3.5	TFT LCD	320 × 240	Predecessor: 24	D-pad, 6 two-w...	No
Archos 105	Unknown	Component, Com...	1.8	OLED	160 × 128	18	D-pad, 7 buttons	No
Cowon Q5W	7	Component, S-vi...	5	TFT LCD	800 × 480	24	Touchscreen	Yes
iPod nano 6G	No video support	Component, com...	1.54	TFT LCD	240 × 240		Multi-touch screen	No

Filters

Min Video battery life :

Max Video battery life :

Figure 5.3: Example of a PCM Editor with Warnings and Filtering

The development of the editor in Figure 5.3 shows that the clear semantics of cell contents and the explicit notions of products and features in our metamodel can ease the development of algorithms and services based on PCMs. In comparison to spreadsheets applications, databases or websites, our metamodel avoids developers to manage the structure of the PCM and the parsing of the content cells while reasoning on the PCM.

An Unsatisfying Metamodeling Solution. To evaluate some success factors (*e.g.* learnability, usability) of our model-based approach [105], we gathered informal feedback during our different developments. Our hypothesis was that the Master students could easily learn, understand and manipulate the metamodel of Figure 5.2. However, we observed several issues during the evaluation.

A first issue is related to the mix of the main concepts of the PCM domain with information specific to Wikipedia or editing purposes. For instance, the position of a cell (row and column attributes) is irrelevant in a PCM where products and features are described. Its unique purpose is to support the edition and the import of data. On the one hand, such additional information reduces the comprehension of the domain. On the other hand, it improves interoperability with other formats and languages. The Master students were confused by this concept as they were relying on these positions (and the classic way to handle tables) instead of managing the semantic relationships between products and their associated features. *Our experiments showed that the needs to import and export PCMs raise comprehension and usability issues in the metamodel.*

We also noticed another important limitation. The mix of information in the metamodel, originally designed for domain formalization and import/export purposes, complicates the development of support for edition. This observation was confirmed by the researcher that developed the editor who employed a *simplified* version of the metamodel in order to implement the Web-based editor. This ad-hoc metamodel acted as an intermediate representation that focuses on concepts that are only relevant for editing, thus easing the development of the editor. *Our experiences revealed that the edition tasks were hard to realize with our metamodel.*

In addition, Master's students, as part of the second experiment, complained about the impossibility to directly access of the products and features from the PCM class in the metamodel. Products and features are accessed through an abstract class called *VariabilityConcept* which groups both concepts. Moreover, they are both involved in a composite design pattern. These levels of abstraction enable a precise description of a PCM but hinder the navigation in the model. The lack of direct get/set methods hinders the development of tools for manipulating a PCM such as an extended API. Finally, some students managed the navigation using the positions which are conve-

nient when using a table as concrete representation for a PCM but may be not relevant for another kind of data visualization. Moreover, adding a feature or a product to a PCM requires to set an arbitrary position, thus further hindering the genericity of the underlying API. *The metamodel was not the right solution when it comes to the **manipulation** of PCMs.*

Answer to RQ3. Overall, we came to the following observation: although the metamodel presented in Section 5.1 correctly represents the core domain, the metamodel is not satisfactory for addressing all requirements and tasks (related to *interoperability*, *edition*, and *manipulation*). In Chapter 6, we address this problem by developing a domain metamodel and separating each concern in a task-specific metamodel.

5.4 Threats to Validity

5.4.1 Internal Validity

In order to avoid a bias while evaluating our PCMs, we removed from the evaluation set all the training material, including the PCMs used during our previous work, and the PCMs we used to build and test our interpretation rules.

Size and well-formedness are important factors in the PCM analysis. During the experiment, large matrices (more than 1000 cells) and badly designed PCMs are often source of reject. Four of our evaluators mentioned that the largest PCMs were painful to read and analyze and one of them has voluntarily skipped them. If it highlights and justifies the necessary work toward better PCMs and PCM editors, it also sets the question of the optimal size of an exploitable (standard or model-based) PCM for a human.

For this evaluation, we obtain heterogeneous results since our classification is evaluated by different persons. Though we made our possible to evaluate each PCM twice or more, the random access to PCM cannot guarantee that participants evaluate all PCMs equally.

5.4.2 External Validity

A threat to validity is the applicability of our metamodel and automated techniques to other PCMs (outside Wikipedia). We progressively defined the metamodel according to our analyses of several PCMs found here and there on the internet, i.e., we did not restrict ourselves to PCMs from Wikipedia (see [12] for more details). The Wikipedia dataset is publicly available but challenging since it covers various domains and exhibits a high degree of heterogeneity. The mining of other PCMs is an additional challenge to address before diversifying our dataset.

Our evaluators are engineers, researchers (PhD students) in software engineering. Consequently, they are familiar with computer interfaces, modeling/typing that can be potentially not intuitive during the evaluation. We have carefully documented and tested our tutorial in order to provide sufficient and sound examples of typical *Constraints* for the semantics of valued cells so that it can be reused outside this community.

This empirical study does not detect false negatives: matrices that cannot be interpreted as PCMs, for instance Wikipedia timelines, have been either removed or detected as such by participants.

5.5 Conclusion

PCMs are simple, convenient, easy means to provide a lots of rich and useful information about a set of products. However, they present many drawbacks such as heterogeneity and ambiguity, lack of formalization, lack of tool support and efficient services.

To address these problems, we developed a model-based approach. The first element of this approach is a metamodel that precisely defines both the structural and semantical aspects of PCMs. The metamodel adopts a product line view of a PCM with the products and features as main concepts. Moreover, the semantics focuses on variability pattern that we can find in existing PCMs. The second element of the approach is an automated transformation chain that converts

raw PCMs into PCM models. The transformation mainly relies on a set of rules to extract the different variability patterns of the metamodel from the textual information contained in cells.

To elaborate our approach, we followed the iterative process detailed in Chapter 4. With our methodology, the elaboration of the metamodel is mainly data-driven. Our evaluation on 75 PCMs from Wikipedia shows that the precision of our transformation chain reaches 93.11% for a fully automated process.

The design of the metamodel is also user-driven. The editor that we developed for our evaluation allowed us to gather feedback from end-user. With the editor, we do not directly evaluate the metamodel or models in classical object notation. Instead, we present the concrete syntax of models of PCMs. As such, we do not require the participants to have any knowledge on modeling. It allows to put the end-user in the loop of our iterative process and thus measure the relevance of the concepts of the metamodel. Our evaluation highlighted the soundness of the concepts of our metamodel but also 3 emerging concepts that we will need to add. It also calls for further research effort in order to clarify the semantics of the *Multiple* concept and its sub-concepts.

With our metamodel, developers can directly manipulate the concepts of features and products. Compared to spreadsheets or databases, this eases the development of algorithms and services for PCMs. However, the feedback gathered during our experiments also revealed limits to the comprehension of our metamodel and its usage in this context. This highlights that the design of the metamodel should also be driven by services. It prompted us to refine our approach (see Chapter 6) in order to offer a pertinent framework for the development of services for PCMs.

Chapter 6

A Multi-Metamodel Approach

"The first Matrix I designed was quite naturally perfect, it was a work of art, flawless, sublime. A triumph equaled only by its monumental failure."

The Architect

In Chapter 5, we presented a model-based approach for automatically formalizing PCMs. The core of this approach is a metamodel describing the structure and semantics of PCMs. Our evaluation showed that the formalization was precise and ease the development of services on top of PCMs in comparison to general table edition tools (*e.g.* spreadsheets or databases). However, we also noticed that the metamodel presents comprehension and usability issues. This hinders the exploitation of the PCM models. In this chapter we refine this first approach to further ease the development of services for PCMs. The idea is to separate each concern in a specialized metamodel (see Section 6.1). The design of this new approach follows the same iterative process as previously (see Chapter 4 for details). In comparison to the previous approach, we base our evaluation on a larger dataset of more than 1,500,000 PCMs and the feedback gathered during numerous developments of services. Section 6.2 presents a metamodel dedicated to the manipulation of PCMs and how it can be used to compare, configure and analyze product lines through a PCM. Section 6.3 focuses on the elaboration of a metamodel for the development of an editor. Section 6.4 presents the importing and exporting capabilities of our new approach. Section 6.5 evaluates the new approach with respect to the three research questions defined in Chapter 4. All these techniques and services are integrated in a project called OpenCompare (see Section 6.7).

6.1 Going From One Metamodel to Multiple Metamodels

The evaluation of the metamodel of Chapter 5 shows that a unique metamodel is not a satisfying solution. To improve our first approach, we propose to separate each concern in a specialized metamodel (see Figure 6.1). The central element of our new approach is a metamodel that precisely and solely represents the domain of PCMs (see Figure 6.2). In particular, we focused on the comprehension the metamodel during its design. This domain metamodel refines the metamodel of Chapter 5 (see Figure 5.2) by eliminating several concepts and information that are not necessary for describing the PCM domain. For instance, the cell's relative position, the domain of a feature and the subclasses of a cell. The concepts for defining the semantics of the cells are refined and completed according to the results of our evaluation (see Section 5.3). In addition, we implemented 3 rules to further constraint the metamodel and thus refine what is a PCM model:

- no duplicated features
- no duplicated products
- each couple of feature and product must bind to a cell

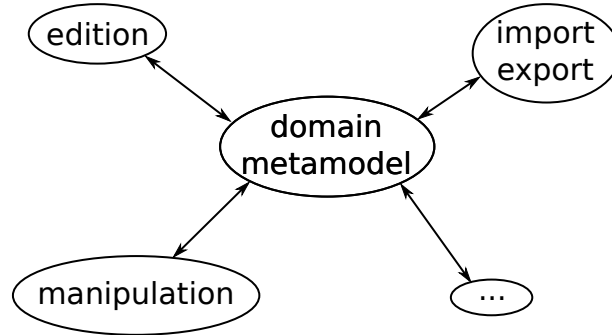

Figure 6.1: Overview of our new approach: task-specific metamodels gathered around a central domain metamodel

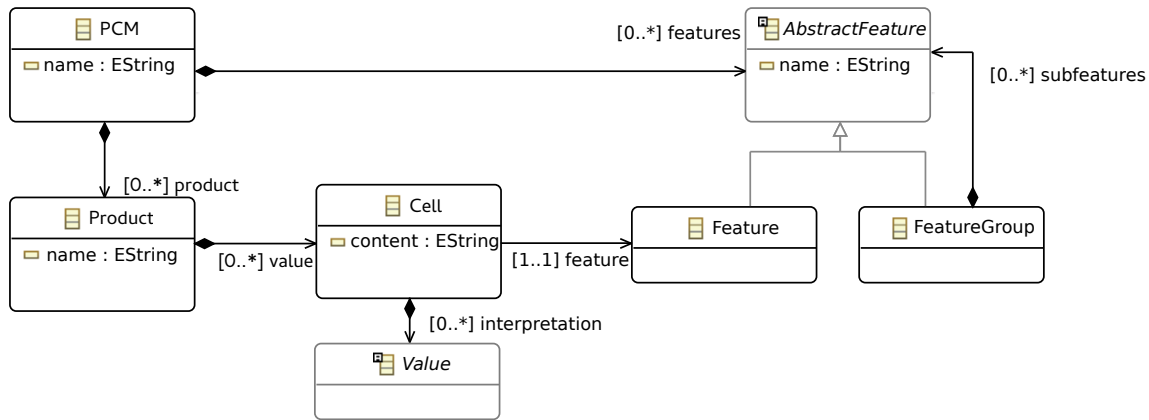

Figure 6.2: Excerpt of the domain metamodel

With these modifications, we remove the information related to other concerns (*e.g.* import or edition of PCMs). As such, the domain metamodel has the right expressiveness level and does not contain any redundant or unnecessary information. This simple metamodel can be easily used to understand and communicate on what is a PCM. However, this simplicity hinders the development of services. Task-specific metamodels must be designed to ease this development. The domain metamodel acts a central formalism in order to enable the communication between the different task-specific metamodels.

In comparison to a solution with a single metamodel, this approach leads to well known synchronization problems between the models. However, these problems are only related to the implementation of a task-specific metamodel. For the user of this metamodel, there is no overhead. We shifted the complexity of the metamodel from the user to the developer. Therefore, it can potentially ease the development of services. In the following sections, we will show how we were able to implement several services (editor, comparator, statistics, *etc.*) on top of this new approach.

6.2 Manipulation and analysis of PCMs

A first objective of our model-based approach is to provide generic algorithms for exploring and exploiting PCMs. The ability to manipulate a PCM is thus crucial. We observe that the domain metamodel offer only basic getters and setters and thus it is not suitable for the development of such tools. Therefore, we enriched the domain metamodel with generic operations, leading to the metamodel of Figure 6.3. In particular, we provide a built-in *visitor* design pattern that ease the traversal of a PCM. Common operations such as getting the set of *Feature* and normalizing a PCM

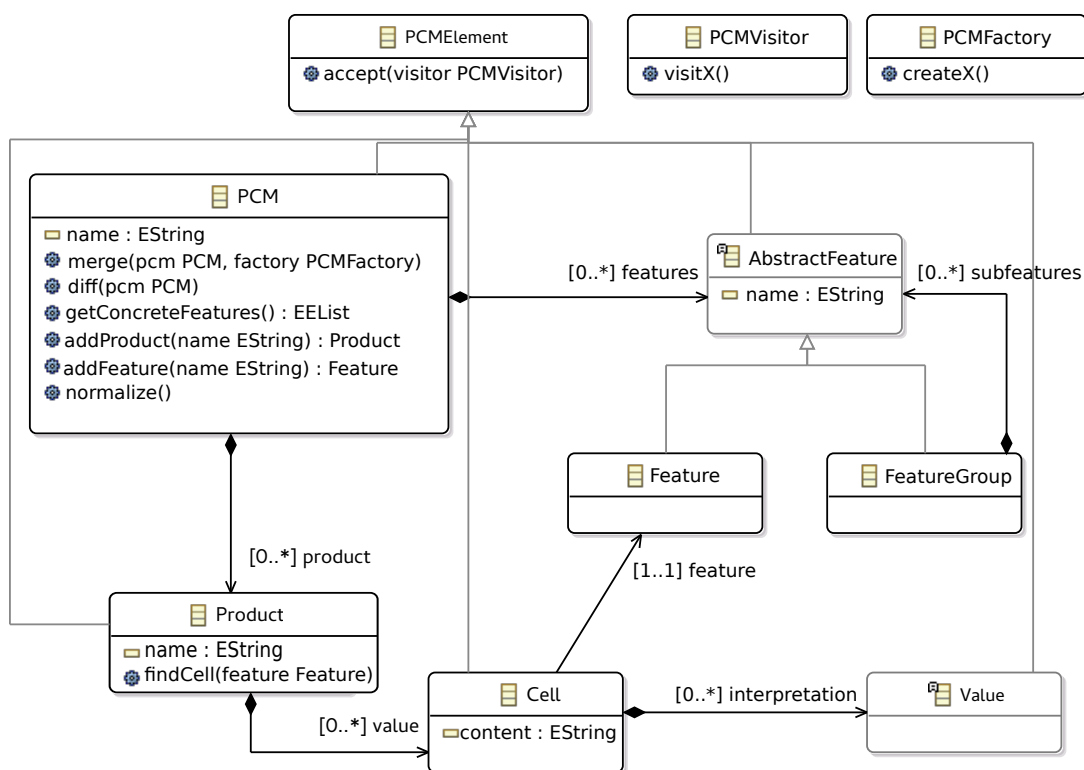

Figure 6.3: Metamodel for API

(i.e. creating missing cells or features) are also integrated in the metamodel. In addition, we provide operations for merging and comparing two PCMs. Overall, this metamodel is used as an API over PCM models and can be used to develop numerous services.

6.3 Edition of PCMs

An important service that we provide with our approach is an editor for PCMs. Figure 6.4 shows the editor in action on our example of Figure 2.1. It allows to create and modify PCMs while manipulating concepts and performing operations relevant to the domain. For instance, one can create a feature or a product instead of a column or row. Moreover, we make use of all the capabilities of the comparator of OpenCompare in order to propose sorting, filtering and visualization capabilities during the edition. This allows the user to extract the relevant information for his or her edition task.

The core aspect of the editor is the use of a matrix to represent the PCM. The position of the features, the products and the cells are thus very important for the implementation of the editor. However, they are absent in the domain metamodel and the metamodel for the API in order to improve their comprehension and usability. Working directly with these metamodels would result in numerous operations for computing the positions. Moreover, the manipulated concepts would not reflect the graphical representation thus hindering the comprehension of the editor implementation. Therefore, we decided to design a new metamodel. Figure 6.5 shows the metamodel used for the implementation of our editor. It contains simple concepts of *Row*, *Column* and *Cell* that are related to the graphical representation of PCMs. In addition, it offers operations to manipulate the rows and columns and validate the type of the cells. This last operation is used when a user hit the *validate* button in order to highlight cells that are considered as inconsistent with the rest of the column.

Product	Model	SoC	Storage Capacity	Weight
Product 1	Nexus 6P	Snapdragon 810	32 GB, 64 GB, 128 GB	178g
Product 2	BlackBerry Priv	Snapdragon 808	32 GB	192g
Product 3	Sony Xperia Z3+	Snapdragon 810	32 GB	144g
Product 4	Samsung Galaxy S6	Exynos 7420	32GB, 64GB, 128GB	138g
Product 5	Apple iPhone 6S	Apple A9	16 GB, 64 GB, 128 GB	192g

Figure 6.4: Editor of OpenCompare

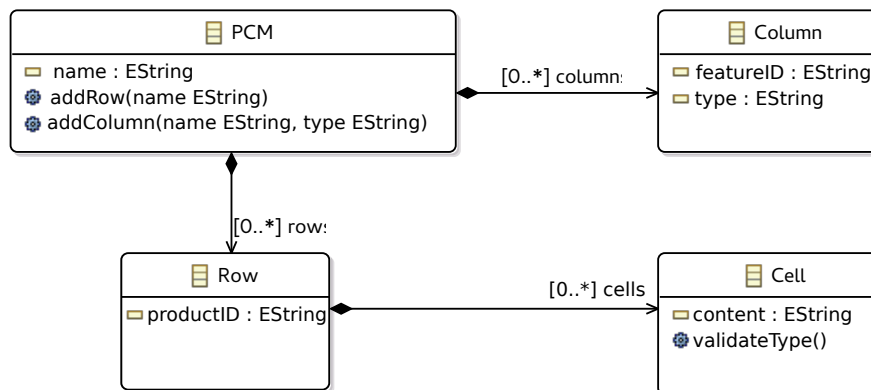

Figure 6.5: Metamodel for editor

6.4 Importing and Exporting PCMs

6.4.1 A Unified Format

In Chapter 5, we present a set of transformations that gradually formalize PCMs into PCM models. They mainly rely on the positions of the cells and specific operations to normalizing a PCM and finally produce a PCM model. In this context, the main purpose of the metamodel is to abstract away the complexity of the concrete input format while keeping a low-level representation of a table. In our new approach, none of the previously described metamodel is appropriate for the development of such transformations. The domain metamodel and the metamodel for manipulating PCMs do not contain positions of the cells. Moreover, the metamodel for the editor is offering operations that are irrelevant to the normalization of PCMs.

Following our approach of creating a metamodel for each concern, we therefore create a metamodel for importing and exporting PCMs (see Figure 6.6). This new metamodel is composed of two classes: *IOMatrix* and *IOCell*. An *IOMatrix* is composed of a set of *IOCell* indexed by their positions. Each cell contains information about its content and if it spans multiple rows or columns. The metamodel reflects the structure and semantics of most table input formats such as

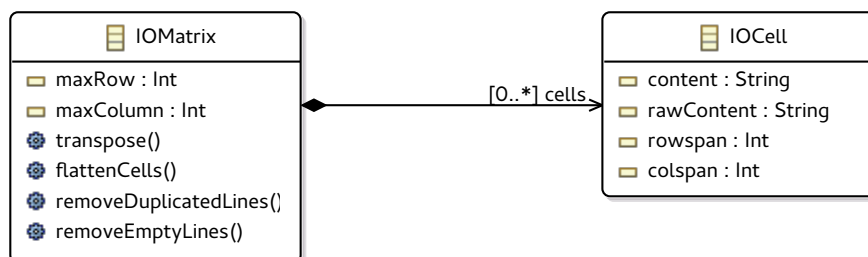

Figure 6.6: Metamodel for importing and exporting PCMs

CSV, HTML or wikitext while being completely generic. An important part of the formalization of PCMs is to normalize a matrix. For that purpose, the *IOMatrix* class provide a set of specialized operations. The *transpose* method allow to reorient the matrix in order to have the classical representations with products as rows and features as columns. The *flattenCells* method unfold the cells that span multiple rows or columns. Finally, the *removeDuplicatedLines* and *removeEmptyLines* are provided for cleaning a matrix. Overall, the metamodel acts as a unified format for the development of import and export services for PCMs.

6.4.2 Importing PCMs

Based on this new metamodel, we now adapt our solution of Chapter 5 in order to provide generic transformations for importing PCMs and further automate our process. The first step of the formalization is to extract from the concrete input format, a model conformant to the metamodel of Figure 6.6. We developed importers for the HTML, CSV and wikitext formats. In addition, we developed an importer for the JSON format that we use internally for serializing PCM models. Now that we have an *IOMatrix*, we apply generic transformations in order to get a PCM model. We now detail each transformation.

Normalization. The first transformation consists in normalizing the *IOMatrix*. We clean it by using a combination of the provided operations of the metamodel (*transpose*, *flattenCells*, *removeDuplicatedLines* and *removeEmptyLines*). It results in a simple matrix which has no duplicate lines or columns and no cells spanning multiple positions. This normalization reduces the complexity of the subsequent transformations.

Type inference. From this normalized matrix, we reuse the rules of Chapter 5 based on regular expressions in order to infer the type and semantics of each cell.

Orientation detection. In order to identify the features, products and cells contained in our PCM, we need to detect its orientation, *i.e.* detect if the products are represented as rows or columns. Similarly to the work of Chen *et al.* and Wang *et al.*, we base this detection on the types of the cells [57, 183]. The rationale behind our algorithm is that the cells of a same feature are referring to the same domain and thus are more likely to have the same type. For instance, in our example of Figure 2.1, the last column has only numerical values while all the rows have a combination of different types. The orientation of the PCM is more likely to be in the form of products represented as rows and features as columns.

To detect the orientation, we compute the homogeneity of the rows and columns. We define the homogeneity of a row (resp. column) as the number of cells of the most represented type divided by the total number of cells in the row (resp. column). Then, we compute the average of the homogeneity for both rows and columns. If the score for the rows (resp. columns) is higher, then we return that the features are represented as rows (resp. columns). Finally, to further normalize the matrix, we reorient it such that features are represented as columns.

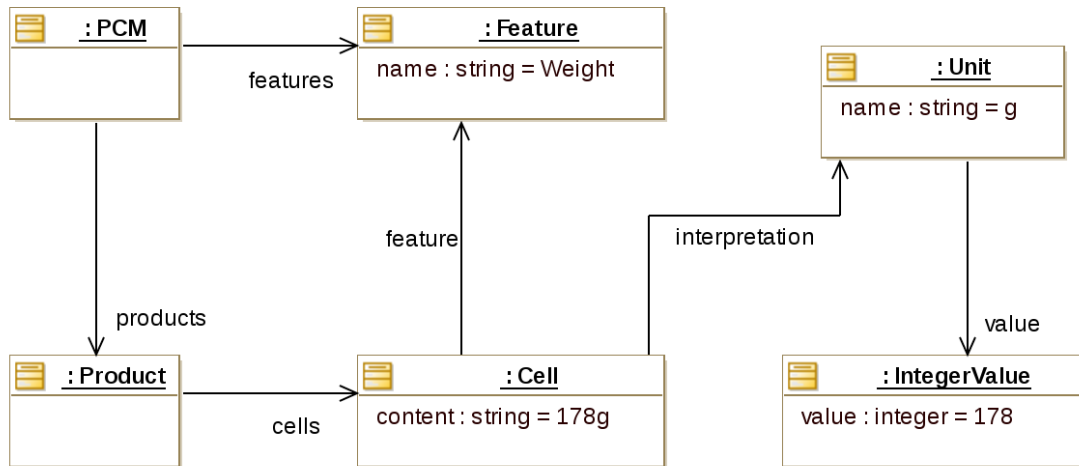

Figure 6.7: Excerpt of the model resulting from the import of the PCM of Figure 2.1, page 12

Feature hierarchy extraction. At this point, the input matrix is normalized and the semantics of the cells are known. We can now focus on the extraction of the logical structure of the PCM and in particular the hierarchy of features. As the matrix is normalized, we can consider that the features are located in the first rows of the matrix. Our algorithm for extracting the hierarchy of features starts at the first row. If there is consecutive cells that contain the same value, then they form a *feature group*. Otherwise, the cell is considered as a feature. The algorithm iterates on the rows until a unique feature is found for each column, *i.e.* no more feature group is detected.

Product extraction. Once we have the hierarchy of features, the remaining rows of the matrix correspond to the products of the PCM. The extraction of the product is thus straightforward. It results in a complete PCM model that represents a formalization of the original input matrix. Figure 6.7 shows an excerpt of the model obtained when importing the PCM of Figure 2.1. More precisely, it shows the formalization of the cell containing the value "178g", highlighted in Figure 2.1. We observe that the cell is linked to the feature named "Weight". Moreover, the cell is interpreted as value with a unit named "g". This value is the integer 178. This PCM model precisely captures the semantics of the cell "178g" and its place in the logical structure of the PCM.

Comparison with Chapter 5. By creating a new metamodel dedicated to the import and export of PCMs, we are able to develop generic operations for formalizing PCMs. We also further automate the entire process and in particular the normalization and the detection of the orientation of the PCM. Moreover, as we reuse the rules of Chapter 5 for inferring the semantics of cells, we conserve the precision of the first approach.

6.4.3 Exporting PCMs

An important property of PCMs is that they are easy to read and understand. They are suitable for displaying information about a set of products in a compact way. It is natural to publish a PCM on a Web page or print it in order to share its information. Moreover, if one imports and edits a PCM with OpenCompare, it can be interesting to propagate the modifications back in its original format. To extend the functionalities of OpenCompare, we can also need to interoperate with external tools. For instance, we could create statistics about a PCM or a set of PCMs with the R programming language. All these scenarios require to export a PCM model into another format.

To increase the interoperability of PCM models, we developed a generic transformation chain that exports an *IOMatrix* from a PCM model. In addition to the PCM model, the procedure takes as input the positions of the cells and the desired orientation of the PCM. The procedure consists

Table 6.1: Statistics on the structure of PCMs

Metrics	Min	Median	Mean	Max
Products	1	6	12.4	5879
Features	1	5	5.8	3308
Cells	1	30	73.4	41,153
Empty cells (%)	0	0	7.1	99.4

in positioning the features and cells in order to have a canonical representation of a PCM like in our example of Figure 2.1. As the metamodel provides a method for transposing an *IOMatrix*, the exporter only need to focus on one orientation. The other one is given for free after calling the *transpose* method. The development is thus simplified. From this *IOMatrix*, we can generate other formats. For instance, we developed specific exporters for CSV, HTML, wikitext and JSON formats.

6.5 Evaluation

In this section, we evaluate our new approach for the formalization of PCMs with respect to the three research questions of Chapter 4. In particular, we measure the usage of the concepts of the metamodel on a larger scale than the evaluation of Chapter 5. We also evaluate the robustness and precision of our transformation of raw PCMs to PCM models by using metamorphic testing (see Chapter 4 for details). Finally, we report our experience on the development of numerous services based on our metamodels. These services were implemented by researchers and Master students.

6.5.1 Experimental settings for RQ1 and RQ2

Wikipedia regularly creates a compressed dump of all its articles and associated resources. We downloaded a dump that was created in 2nd November, 2015. It contains the last version of all the articles of the English version of Wikipedia. This represents exactly 5,000,525 articles in the form of a unique XML file of 51.35GB¹. The objective of this evaluation is to test our formalization procedure on all PCMs of Wikipedia. To handle the amount of data and speed up the computation, we use Apache Spark to distribute the computation on a cluster of computers.

From these 5 millions articles, we are able to extract 1,501,406 PCM models. We want to emphasize that in this study we do not distinguish PCMs from regular tables. As such, the extracted PCM models may not actually represent PCMs. Table 6.1 presents general statistics on the structure of the PCMs. A first observation is that the large majority of PCMs are rather small. About 65% of them have at most 10 products and features. A second observation is that Wikipedia PCMs contain few empty cells. For 64% of the PCMs, all their cells contain at least one character.

6.5.2 RQ1: Is our metamodel complete and relevant to the formalization of PCMs?

Metrics. The particularity of this evaluation is to evaluate our formalization procedure on a large dataset of PCMs. In this context, we cannot manually verify the correctness of each PCM regarding its input raw table. Therefore, we use a set of metrics that allows us to have a statistical view of the results.

A first metric is the depth of the feature hierarchy of a PCM. In the metamodel, it is represented by the composite pattern involving the classes *AbstractFeature*, *Feature* and *FeatureGroup*. The feature hierarchy allows to categorize features. For example, in Figure 6.8 the features L1, L2 and L3 are grouped under the feature Cache (KiB). It indicates that these features are 3 types of cache. In this example, the depth of the feature hierarchy is 2.

¹It corresponds to the file *enwiki-20151102-pages-articles-multistream.xml.bz2* available at <https://dumps.wikimedia.org/enwiki/20151102/>

FSB/HT(MHz)	Cache (KiB)			Memory Controller
	L1	L2	L3	

Figure 6.8: Hierarchy of features in a PCM about the comparison of AMD processors in Wikipedia

Table 6.2: Use of the domain metamodel concepts

Boolean	0.1%
Integer	23.4%
Double	1.7%
String	44.6%
Not Available	9.4%
Conditional	2.1%
Partial	0.01%
Multiple	7.7%

A second metric is the proportion of cells being interpreted as one of the types defined in the domain metamodel (sub-classes of the class *Value*). These two metrics report on the usage of the concepts in the domain metamodel.

Handling templates. As we have seen in Section 4.1, the wikitext format allows to define templates. A template is a kind of macro that takes textual parameters and produces wikitext code potentially containing other templates. To retrieve the text that will be displayed, the templates need to be expanded. This operation requires a direct access to Wikipedia. In the context of our experimental study, this would require a number of accesses which goes beyond the limits supported by Wikipedia and the cluster that we are using. As a consequence, the content of the cells that we extract are not necessarily reflecting the information displayed to users of Wikipedia but rather technical details of the wikitext format. Our techniques for inferring the semantics of a cell are agnostic of the format and thus do not support templates. This hinders the analysis of the semantics of the cells as we did in the evaluation of Chapter 5. To have comparable results with Chapter 5, we consider only the 886,618 PCMs that do not rely on templates for computing the statistics on the types of the cells.

Results. The first metric shows that the feature hierarchy that we extract has a maximum depth of 2. More precisely, the maximum depth is reached in 13.6% of the cases. This shows that the class *FeatureGroup* is needed in our metamodel to express the hierarchical organization of features in PCMs. Yet, the low depth of the hierarchy challenges the need for a composite pattern. A simple hierarchy of depth 2 could be statically encoded in the domain metamodel. However, we observe deeper hierarchies in PCMs outside Wikipedia. We also think that the composite pattern allows a greater flexibility in our formalism and thus support a larger class of PCMs.

Table 6.2 shows the results for the second metric. We observe that our formalization procedure uses all the types of cells defined in the metamodel. Compared to the previous approach of Chapter 5, the distribution of types is different. A notable difference is the low percentage of *Boolean* cells. Wikipedia contributors often use the templates *yes* and *no* to express Boolean values. Basically, these patterns change the background color of a cell to respectively green and red. As we mentioned before in the experimental settings, we do not support templates in this evaluation. Therefore, we miss a significant number of these values which falls into our default *String* type.

Answer to RQ1. Overall, these metrics show that the concepts in our domain metamodel are used in the context of modeling PCMs. Compared to the metamodel of Chapter 5, our domain metamodel is simpler but still provides the necessary concepts for the domain of PCMs.

6.5.3 RQ2: What is the precision of our transformation of raw PCMs to PCM models?

Metrics. To test the precision of our transformation, we rely on metamorphic testing [59] (see Chapter 4 for more details). In our context, we use metamorphic testing to check if exporting a PCM model and importing it back results in the exact same PCM model. In this evaluation, we test this property on our 4 couples of importers and exporters: HTML, CSV, wikitext and JSON. The metric that we use for evaluating RQ2 is the percentage of PCMs that pass the metamorphic tests.

Results. As we mentioned in the experimental settings, we are able to extract about a million and half PCMs from our dataset. Only one error occurred during the import of all these PCMs. This error is due to the library that we use for parsing wikitext code and thus is not caused by the implementation of our procedure. It shows that our wikitext importer and our generic formalization procedure support a large variety of PCMs.

Our metric on metamorphic testing indicates that out of the 1,501,406 PCMs in the dataset, we are able to correctly export in all formats and import back 91% of the PCMs. In particular, the import and export of our JSON internal format works in all the cases. For CSV and HTML formats, the precision reaches 92.8%. For the wikitext format, the precision is a bit lower with 91.9%. This can be explained by the increased complexity of the wikitext format compared to CSV and HTML.

During these experiments, we discovered several bugs in our importers and exporters. For instance, we detected that the parsing of parameters of templates expressed in wikitext was sometimes incorrect. It shows the interest of performing metamorphic testing (or other testing techniques without oracle) when modeling a large dataset of raw data. It also helps us to improve our procedure and specify new unit test with an associated oracle.

The results show that the precision of our importers and exporters is not maximal. To qualify the sources of errors, we randomly selected 25 failing metamorphic tests and manually analyzed the results.

A first source of error is the presence of tables that are not PCMs in our dataset. As we explained in our experimental settings, we do not distinguish between PCMs and regular tables. Our importers are not designed to support other types of tables than PCMs. Thus, they fail to produce a PCM model that is supported by our tool chain.

A second source of error is the incorrect detection of the orientation of the PCM (products represented either as rows or columns). Our algorithm for detecting the orientation of a PCM rely on the homogeneity of the types of the cells. We noticed that the presence of unknown values may disturb the computation of the homogeneity which results in an incorrect orientation of the PCM.

A third source of error is the incorrect support of some characters (*e.g.* line breaks, # or ||). For line breaks, it usually affects the presentation of the content of the cell and not its essential information. However, Wikipedia contributors use the double pipe (||) to separate cells. If it is not interpreted correctly, it changes the structure of the analyzed table and thus the PCM model.

Other sources of errors may be discovered with a more thorough analysis of the results. To avoid the errors that we detected, we need to be able to detect tables that are not supported by our tool chain. We also need to improve the precision of our algorithm for detecting the orientation of a PCM. However, these errors arise only in an automated setting. When performing a manual import and export of a PCM, a user can manually check if a table fits our definition of a PCM.

Answer to RQ2. Our importing and exporting capabilities are able to handle a large variety of PCMs with a important precision of 91%. The formalization errors mainly come from the presence of table that are not PCMs in our dataset and the incorrect detection of the orientation of the

PCMs. This evaluation also calls for further development effort to reach a precision of 100% for our metamorphic tests.

6.5.4 RQ3: Is our metamodel suited for engineering automated analyses and services dedicated to PCMs?

The design of the new approach presented in this chapter led to numerous and various experiments and developments. We now present the services resulting from these experiments and the feedback that we gathered from the developers. The following list shows what was developed and who was involved:

- Web editor, comparator, configurator and visualizations for PCMs (1 Master student and 1 researcher)
- *MatrixMiner*, a tool for extracting a PCM from informal product descriptions [10]. The resulting PCM is displayed and refined by an editor derived from the one of OpenCompare. (4 researchers)
- Importer and exporter for HTML, CSV and wikitext formats (1 Master student and 1 researcher)
- Browser extensions for Chrome and Firefox in order to replace a PCM in a website by our editor (1 Master student and 1 researcher)
- Configurable HTML exporter. The color of the cells and the representation of certain types of data can be customized. (15 Master students)
- Visualization of the products in a 2D space. It is inspired from the website productchart.com. (1 researcher and 20 Master students)
- Machine learning techniques for finding new types of data contained in cells of PCMs from Wikipedia (3 Master students)
- Statistics on the types of data contained in cells (45 Master students)
- Extraction of information that stands out in a PCM. The information is presented as text. (45 Master students)

Manipulation. During the last 2 years, we implemented a comparator, a configurator and statistical visualizations that are all integrated in a same website.

The comparator (see Figure 6.9a) was developed by one researcher and two students. It shares the same graphical representation as the editor presented in Section 6.3. Thanks to the clear semantics of our PCM models, the comparator can offer sorting and filtering capabilities specialized for the kind of data contained in a feature. For instance, the *Weight* feature contain only numerical information. Using this information, we present a range of integers that the user can specify in order to filter the products (see Figure 6.9b). For the *SoC* feature, we have no specific information. In that case, we present a simple list of unique values that can be selected or deselected.

As a complement to our comparator, the configurator of Figure 6.9d offers a different view focused on our filtering capabilities. As we a PCM model is not linked to a particular graphical representation, we can easily switch from one view to the other.

To further explore a PCM, we provide simple charts such as bar charts, pie charts or line charts. They offer a global view on the data and are particularly useful to detect products that stand out. For instance, the bar chart of Figure 6.9c could be used to detect very light or heavy smartphones. An additional innovative visualization² was implemented by Master students from the University of Rennes 1. It is inspired from the website <http://www.productchart.com/>. It consists in displaying the products in a two dimension space. Each dimension represents a feature of the PCM. The complete information about a product is displayed when hovering over its graphical representation in the space.

²The visualization is still experimental at the moment and thus it is not integrated in OpenCompare yet.

By offering an easy traversal of the PCM, the the metamodel for manipulating PCMs allows to extract statistics about the data contained in PCM. In particular, different promotions of Master students from the University of Rennes 1 and ENSAI performed statistical analyses on the number of products and features contained in PCMs in Wikipedia. They also analyzed the distribution of types of data as we did in Chapter 5. Contrary to our previous approach, the students did not have any difficulties to understand and use the metamodel.

In addition, a preliminary study was performed by a Master student that took part in the development of our import and export services. It consists in analyzing the evolution of Wikipedia PCMs over time. For that purpose, the student used the *diff* operation of the API. His feedback was also encouraging concerning the usability of the API. We plan to continue this study in order to understand the creation of PCMs and thus further motivate our work and guide the development of OpenCompare.

Edition. Compared to the editor developed in Chapter 5, we find the same core features in our new editor (see Section 6.3). The difference is that its implementation is greatly simplified thanks to the reduced complexity of the metamodel and the relevance of his concepts regarding the edition task. The students that participated in the development confirmed that having a specialized metamodel simplified their tasks. In addition, before the development of this editor, 4 Master students worked on another implementation with a different Web technology. Despite the initial wrong choice of technology, the feedback on the metamodel was also encouraging.

Import and export. The import and export capabilities described in Section 6.4 offers a generic way to transform raw PCMs into PCM models. With this new transformation, the integration of an importer for a different format requires to transform the format into a model conformant to the metamodel of Figure 6.6. As our metamodel is close to the structure of the formats that we are considering, the implementation of this last step is straightforward. If the metamodel for importing PCMs is not appropriate for a specific format, the developer can also directly produce a PCM model. Overall, by providing a specific metamodel and generic transformations, we ease the development of importers of PCMs and our approach becomes more generic and automated. Similarly to importers, our dedicated metamodel eases the development of exporters of PCMs.

Answer to RQ3. The informal feedback gathered during our development experiments shows that despite tiny problems due to the lack of maturity of the implementation, the global impression was good. The domain metamodel was easy to present and the different students and researchers did not have difficulties to understand it. In a few lines of code, they were able to manipulate a PCM and extract relevant information. For more complex development (*e.g.* the Web editor, *MatrixMiner* and the importers and exporters), the participants really benefited from the task-specific metamodels. This feedback shows that the new approach with multiple metamodels greatly eases the implementation of services in comparison to the first approach with a unique metamodel.

6.6 Threats to Validity

6.6.1 Internal Validity

During this chapter, we evaluated our new approach regarding its capacity to provide a basis for the developments of services for PCMs. A first threat to internal validity is that this evaluation is based on informal feedback which are by nature subjective. To mitigate the bias, we tried to perform numerous experiments with researchers, engineers and students.

A second threat to validity is the absence of filter for non PCMs in our study of Wikipedia. On the one hand, mixing PCMs and other kinds of tables may significantly impact the results of our metrics. On the other hand, it makes the problem harder and show the robustness and completeness of our approach in various situations.

A third threat is the inherent limits of metamorphic testing. The property that we are testing requires a PCM model. To obtain the initial models, we perform a first import with our wikitext

Product	Model	SoC	Storage Capacity	Weight
Product 1	Nexus 6P	Snapdragon 810	32 GB, 64 GB, 128 GB	178g
Product 2	BlackBerry Priv	Snapdragon 808	32 GB	192g
Product 3	Sony Xperia Z3+	Snapdragon 810	32 GB	144g
Product 4	Samsung Galaxy S6	Exynos 7420	32GB, 64GB, 128GB	138g
Product 5	Apple iPhone 6S	Apple A9	16 GB, 64 GB, 128 GB	192g

(a) Comparator of OpenCompare

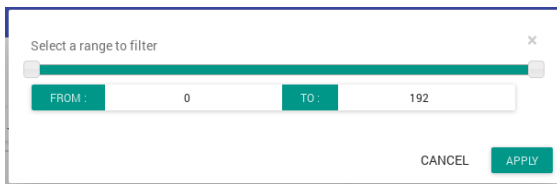

(b) Filter

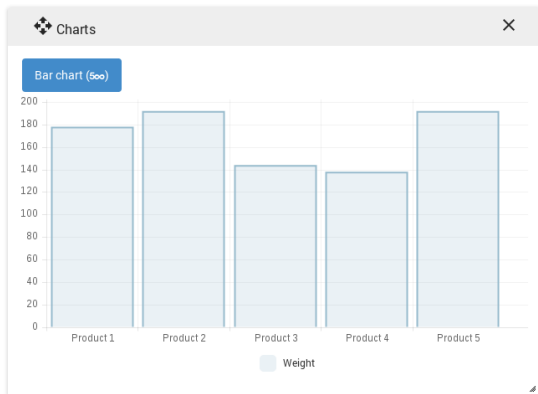

(c) Bar chart of the Weight feature

Product Search

Find

▼

Model ▼

Nexus 6P

BlackBerry Priv

Sony Xperia Z3+

Samsung Galaxy S6

Apple iPhone 6S

SoC ▼

Snapdragon 810

Snapdragon 808

Exynos 7420

Apple A9

Storage Capacity Number

0 32

Weight Number

0 192

(d) Configurator

Figure 6.9: Services for exploring a PCM in OpenCompare

importer. The presence of bugs in this importer may not be revealed by the subsequent metamorphic testing. However, this technique is necessary for testing the OpenCompare on the entire dataset. Moreover, each bug discovered by metamorphic testing improves the accuracy of the initial import and thus reduces the bias.

A fourth threat is that our evaluation procedure may present implementation errors. To avoid any bias, we thoroughly tested our procedure on a smaller scale and compared our results with previous experiments. In addition, we execute OpenCompare tools and observe the resulting PCMs. To compute the different statistics, we rely on the R programming language.

6.6.2 External Validity

The main threat to external validity is that we evaluate OpenCompare only on the English version of Wikipedia. Testing OpenCompare on a different version of the encyclopedia or on another source of PCMs may result in different results. We chose Wikipedia because it offers a great diversity of domains. Moreover, there are no guidelines for the edition of tables which also leads to diverse practices in the definition of PCMs.

6.7 OpenCompare: An Initiative around PCMs

The new approach presented in this chapter and the related services are integrated in an initiative called OpenCompare. The objective of OpenCompare is to create a community of PCM contributors and users. For that purpose, OpenCompare provide innovative services for PCMs in the form of a website and an API. The facade of the initiative is the website <https://opencompare.org> which groups all our services such as an editor, a comparator, a configurator and importing and exporting facilities (see the following sections for more details).

On the community aspect, we propose to our visitors to create new PCMs or modify existing ones. In both cases, the resulting matrix is visible to everyone. By encouraging a collaborative edition, we hope to increase the quality and relevance of PCMs. In addition, the importing and exporting capabilities of OpenCompare allow to modify PCMs in other websites or formats. For example, one can import a PCM from Wikipedia, modify its content with our appropriate tools and export it back to Wikipedia. In this scenario, at no time the user has to handle the complexity of the wikitext syntax. Finally, we provide a simple way to share a PCM by email, social networks or by directly embedding the PCM in a website.

6.8 Conclusion

In Chapter 5, we present a first approach for the formalization of PCMs. However, our evaluation reveals comprehension and usability issues due to the mix of concerns in its design. To improve the situation we develop, a new approach based on a set task-specific metamodels. The advantage is that we isolate the information relevant to a particular task in a dedicated metamodel. The new approach is integrated in an initiative called OpenCompare. OpenCompare provides an API and innovative services dedicated to PCMs. All these tools are integrated in a Website. Based on this solution, we performed numerous experiments with Master students and researchers. They confirm that OpenCompare eases the development of services while conserving the quality of our initial formalization techniques.

In particular, our import and export facilities allow us to continue our exploration of the PCM domain and in particular in Wikipedia. The large scale analysis of the English version of Wikipedia revealed bugs in our implementation that would be difficult to spot without a realistic dataset. It shows that the iterative process that we used to elaborate our approach (see Chapter 4) is efficient for exploring the diversity of PCMs. Our evaluation also shows that our services are central in this process. They actively contribute to the improvement of the initiative by bringing new data and use cases.

We also want to emphasize that our solution is one possibility among others. Our evaluation shows that our choice of separating the initial metamodel in several ones significantly eases our

tasks. Yet, other techniques could be employed to reduce the complexity of the metamodel and improve its comprehension and usability. For example, aspect-oriented methods [92] could be used to inject task-specific information in the domain metamodel. Another possibility is to maintain a product line of metamodels [39].

Part III

From Product Comparison Matrices to Feature Models

Chapter 7

Breathing Ontological Knowledge into Feature Model Synthesis

"Never send a human to do a machine's job."

Agent Smith

The main objective of this thesis is to formalize PCMs. In Part II, we investigated a first approach based on the definition of a domain specific modeling language. By specifying a set of metamodels and transformations, we showed that we are able to model numerous and various PCMs and provide dedicated services. In this chapter, we investigate another approach based on the synthesis of Feature Models (FMs) (see Section 7.1).

PCMs and FMs share a same goal: describing a product line. For example, the PCM of Figure 7.1a and the FM of Figure 7.1b represent the same product line. Feature modeling is thus a good candidate for the formalization of PCMs. However, we observe a syntactic and semantic gap between PCMs and FMs. On the one hand, PCMs are product-oriented. They describe the comprehensive list of products of a product line. On the other hand, FMs are feature-oriented. They express constraints on a set of features in order to represent the same set of products. The semantics of an FM is defined by a propositional formula. However, PCMs can express more than Boolean information (*e.g.* numerical, textual or uncertain information). Therefore, we investigate the synthesis of FMs from a class of PCMs that we call *Boolean configuration matrices*. Intuitively, Boolean configuration matrices are all the PCMs that can be directly encoded as a propositional formula.

We motivate the importance of the quality of the resulting FM as defined by its configuration and ontological semantics (see Section 7.2). Then, we present generic, automated techniques for breathing ontological knowledge into FM synthesis (see Section 7.3). Our procedure takes a propositional formula as input. A class of PCMs encodable in this formalism are thus supported by our techniques. We also consider various kinds of artifacts that contain or document variability in product lines. In Section 7.4, we describe and illustrate the integration of the synthesis techniques into the WebFML environment. We then perform an empirical evaluation on hundreds of FMs, coming from the SPLOT repository and Wikipedia (see Section 7.5). Finally, we discuss threats to validity and conclude the paper in Section 7.6 and 7.7.

7.1 From PCM to FM

The main objective of a PCM is to represent a set of products in a compact and simple way. A PCM can be considered as a view on a product line. Therefore, to formalize a PCM we need to model its underlying product line. FMs are by far the most popular notation for modeling and reasoning about a product line [46, 110]. FMs offer a simple yet expressive way to define a set of legal *configurations* (*i.e.*, combinations of features) each corresponding to a product of a product

	P1	P2	P3	P4	P5	P6	P7	P8	P9	P10
PostgreSQL	✓	×	×	×	×	×	×	×	×	×
MySQL	×	✓	✓	✓	✓	✓	✓	✓	✓	✓
License	✓	✓	✓	✓	✓	✓	✓	✓	✓	✓
Domain	✓	×	×	×	×	✓	×	✓	✓	×
Proprietary License	✓	×	×	×	×	×	×	×	×	×
Local	×	×	✓	×	✓	×	×	×	×	✓
Programming Language	×	✓	×	×	✓	✓	✓	✓	×	✓
Java	×	✓	×	×	×	✓	×	×	×	✓
Storage	✓	✓	✓	✓	✓	✓	✓	✓	✓	✓
PHP	×	×	×	×	✓	×	✓	✓	×	×
Open Source	×	✓	✓	✓	✓	✓	✓	✓	✓	✓
Wiki	✓	✓	✓	✓	✓	✓	✓	✓	✓	✓
Hosting	✓	✓	✓	✓	✓	✓	✓	✓	✓	✓
Hosted Service	✓	✓	×	✓	×	✓	✓	✓	✓	×

(a) Product comparison matrix (✓ feature is in the product ; × feature is not in the product)

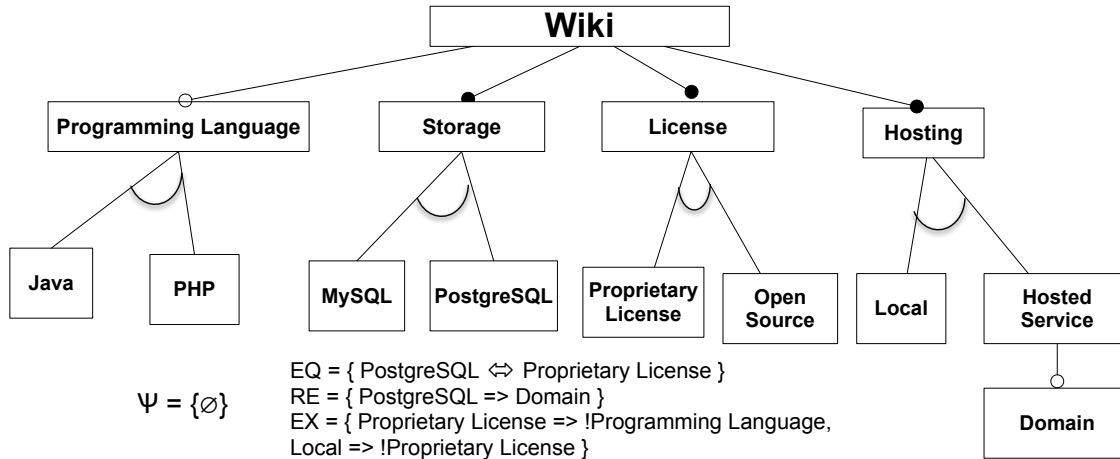
(b) fm_g

$$\begin{aligned}
\phi_g = & // \text{root and mandatory relationships} \\
& Wiki \wedge (Wiki \Leftrightarrow Storage) \wedge (Wiki \Leftrightarrow License) \wedge (Wiki \Leftrightarrow Hosting) \\
& // \text{parent-child relationships} \\
& \wedge (Programming Language \Rightarrow Wiki) \wedge (Java \Rightarrow Programming Language) \\
& \wedge (PHP \Rightarrow Programming Language) \\
& \wedge (MySQL \Rightarrow Storage) \wedge \dots \wedge (Domain \Rightarrow Hosted Service) \\
& // \text{mutual exclusions: at least 1 and at most 1 (Xor-groups)} \\
& \wedge (Java \Rightarrow !PHP) \wedge (Programming Language \Rightarrow (Java \vee PHP)) \\
& \wedge \dots \wedge (Local \Rightarrow !Hosted Service) \wedge (Hosting \Rightarrow (Local \vee Hosted Service)) \\
& // \text{cross-tree constraints (EQ, RE, EX)} \\
& \wedge (PostgreSQL \Leftrightarrow Proprietary License) \wedge \dots \wedge \\
& (Local \Rightarrow !Proprietary License)
\end{aligned}$$

(c) The corresponding formula of fm_g Figure 7.1: An FM with the same configuration semantics than fm_u ($\llbracket fm_g \rrbracket = \llbracket fm_u \rrbracket$) and the PCM of Figure 7.1a while exhibiting an appropriate ontological semantics

line [22, 38, 78, 118, 146, 147, 157, 173]. Another important and dual aspect of an FM is the way features are conceptually related.

In Chapter 3, we show that numerous synthesis techniques for FMs have been proposed, mostly in the context of reverse engineering FMs, but they neglected either configuration or ontological semantics of an FM. There are also few empirical studies investigating how the synthesis techniques behave when ontological aspects of FMs do matter [25].

In this chapter, we describe a *generic* ontologic-aware FM synthesis procedure. To guide the synthesis of an FM, we propose heuristics that rely on general ontologies, e.g. from Wordnet or Wikipedia. They are sound, applicable without prior knowledge or artefacts, and can be used either to fully synthesize an FM or guide the users during an interactive process. We also propose a hybrid solution combining both ontological and logical techniques.

The input of our procedure is a propositional formula which corresponds to the semantics of FMs. In general, PCMs are more expressive than propositional formulas. To address our general problem of formalizing PCMs, we consider a class of PCMs that we call Boolean configuration matrices (see Definition 9). Figure 7.1a presents an example of a Boolean configuration matrix. Such matrices represent a list of products indicating for each feature if the product provide or not this feature. The semantics of Boolean configuration matrices is thus equivalent to propositional formulas.

Definition 9 (Boolean Configuration matrix). *Let $\mathbf{c}_1, \dots, \mathbf{c}_M$ be a given set of configurations. Each configuration \mathbf{c}_i is an N -tuple $(c_{i,1}, \dots, c_{i,N})$, where each element $c_{i,j}$ is a Boolean representing the presence or absence of a feature f_j . Using these configurations, we create an $M \times N$ matrix \mathbf{C} such that $\mathbf{C} = [\mathbf{c}_1, \dots, \mathbf{c}_M]^t$, and call it a Boolean configuration matrix.*

7.2 Ontologic-aware Synthesis

FMs aim at characterizing the valid combinations of features (a.k.a. configurations) of a system under study. A feature hierarchy (a tree) is used to facilitate the organization and understanding of a potentially large number of concepts (features). The configurations represented by an FM is at the heart of its semantics. It is called *configuration semantics*. Another crucial part is the *ontological semantics* which reflects the organization of the concepts and the domain knowledge of the underlying product line. Section 3.1, page 23 defines in detail the syntax and semantics of FMs. We rely on these definitions in the following.

A manual elaboration of an FM is not realistic for large projects or for legacy systems. Many procedures propose to reverse engineer dependencies and features' sets from existing software artefacts – being source code, configuration files, spreadsheets or requirements [20, 21, 81, 89, 120, 139, 151, 153–155, 165, 177, 178, 187]. From these logical dependencies (typically formalized and encoded as a propositional formula in conjunctive or disjunctive normal form), numerous FMs can represent the exact same set of configurations, out of which numerous candidates are obviously not maintainable since the retained hierarchy is not adequate [18, 165]. An example of such an FM is given in Figure 7.2a.

Both configuration and ontological aspects are important when managing FMs. First, the proper handling of configuration semantics is unquestionable. Otherwise the FM may expose to customers configurations that actually do not correspond to any existing product [34, 62, 63, 76, 171]. Second, a doubtful feature hierarchy may pose severe problems for a further exploitation by automated transformation tools or by stakeholders (humans) that need to understand, maintain and exploit an FM – as it is the case in many FM-based approaches [20, 32, 63, 72, 76, 102, 110, 133]. Figure 7.2b depicts a highly questionable user interface of a configurator that could have been generated from the FM of Figure 7.2a and illustrates the consequence of an inappropriate treatment of the ontological semantics.

The problem addressed in this chapter can be formulated as follows: How to automate the synthesis of an FM from a set of dependencies while both addressing the configuration and ontological semantics? Is it feasible to fully synthesize an FM? Can we compute the likely siblings or parent candidates for a given feature? Given a set of dependencies, we challenge synthesis techniques to

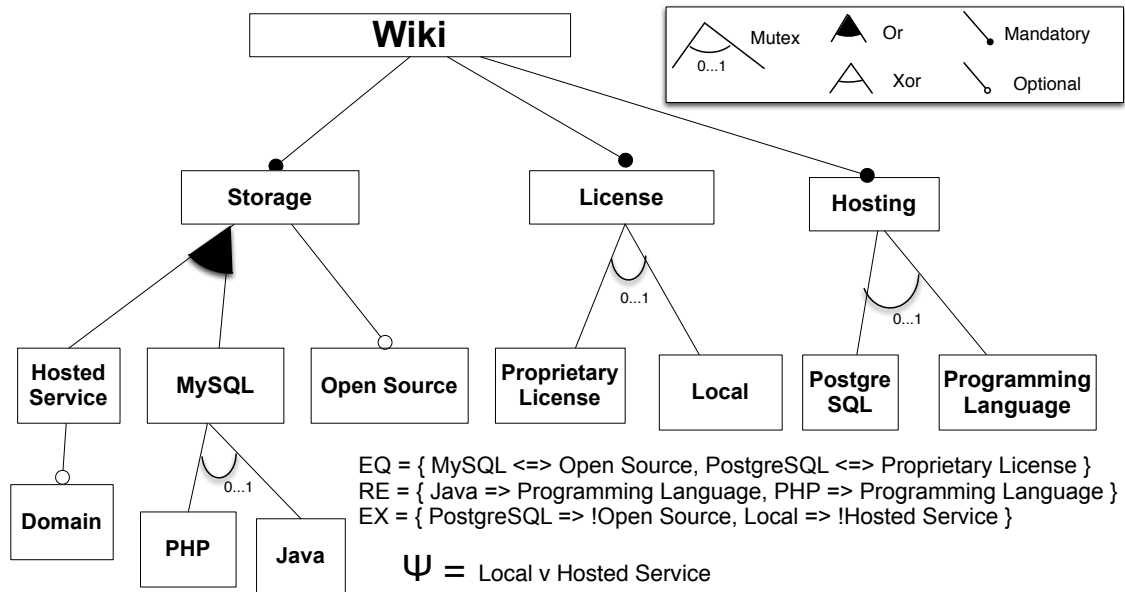

(a) fm_u

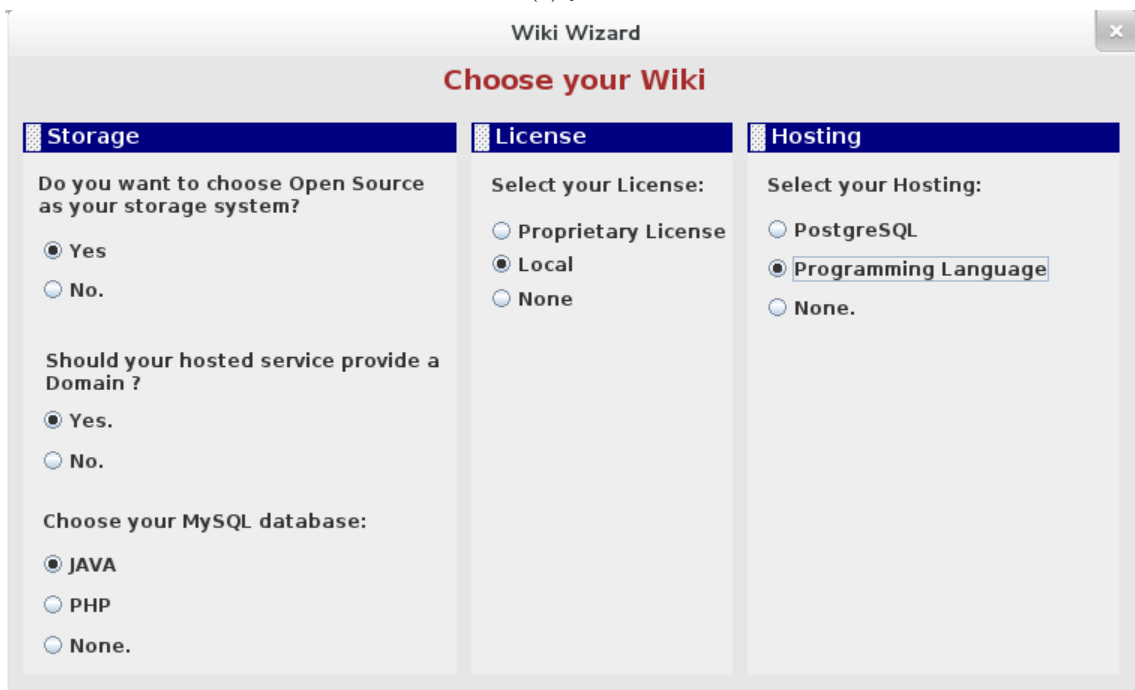

(b) Configurator UI

Figure 7.2: What practitioners do not want. At the bottom, a non intuitive user interface of a configurator that could have been generated from fm_u due to its doubtful ontological semantics.

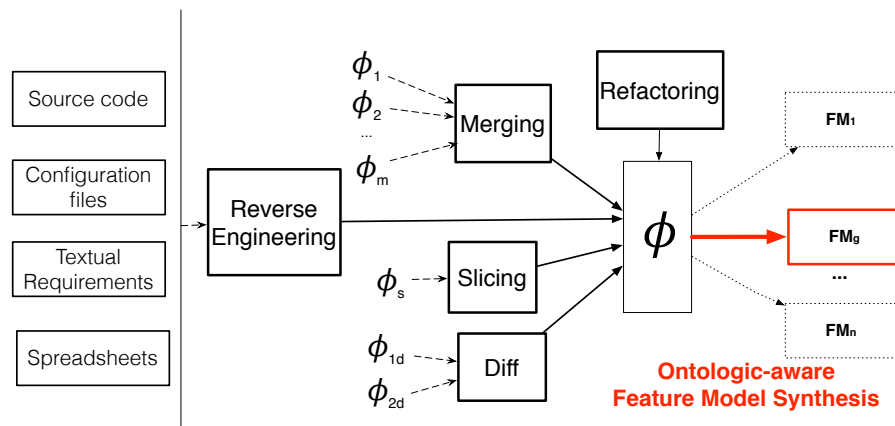

Figure 7.3: A key issue for automated operations: numerous FMs conformant to the configuration semantics of ϕ exist but are likely to have an inappropriate ontological semantics.

assist in selecting a feature hierarchy as close as possible to a *ground truth* – without an *a priori* knowledge of the ground truth.

We now explain the impact of ontological semantics with respect to the FM synthesis, a problem at the heart of many reverse engineering and FM management procedures (see Figure 7.3).

7.2.1 The Importance of Ontological Semantics

Let us consider the following re-engineering scenario (see [48] for more details). After having *reverse engineered* an FM, a practitioner aims to generate a graphical interface (like in Figure 7.2b) for assisting users in customizing the product that best fits his/her needs. Unfortunately, the ontological semantics of the FM is highly questionable (see Figure 7.2a) and poses two kinds of problems.

Automated exploitation. Transformation tools that operate over the FM will naturally exploit its ontological semantics. Figure 7.2 gives an example of a possible transformation from an FM to a user interface (UI). The generated UI (see Figure 7.2b) is as unintuitive as the ontological semantics of the FM is: features PHP and Java are below MySQL, instead of being below Programming Language ; Programming Language itself is badly located below Hosting ; Open Source is below Storage whereas the intended meanings was to state that a Wiki engine has different alternatives of a License. All in all, the series of questions and the organization of the elements in the UI are clearly non exploitable for a customer willing to choose a Wiki.

Human exploitation. One could argue that an automated transformation is not adequate and a developer is more likely to write or tune the transformation. In this case, the developer faces different problems.

First, there are evident readability issues when the developer has to understand and operate over the model. For example, PHP and Java are misplaced below MySQL in the FM of Figure 7.2a. A developer might understand that the MySQL database is implemented either in Java or PHP whereas the intended meaning was to state that the Wiki engine is developed in one of these two programming languages. This fictive example illustrates that an incorrect ontological semantics might induce a developer in error when exploiting an FM.

Second, when writing the transformation, the ontological semantics cannot be exploited as such and the developer has to get around the issue, complicating her task. A solution could be to *refactor* the FM, but the operation is an instance of the synthesis problem (see below). Third, a developer can hardly rely on default transformation rules in case the ontological semantics of the FM is incorrect.

Default rules typically organize siblings in a same UI block. In the example of Figure 7.2b the application of transformation rules leads to a discussable layout in the UI (Programming Language and PostgreSQL, Local and Proprietary License are grouped together). As a result, a developer has to override transformation rules, increasing the effort. Another option is to correct the ontological

semantics (to enable the application of default transformation rules) and thus *refactor* the original FM. The refactoring of an FM is an instance of the synthesis problem, see below.

This scenario illustrates the importance of having FMs with an appropriate ontological semantics for a further exploitation in a forward engineering process. This need is also observed in other FM-based activities such as understanding a domain or a system [20, 33], communicating with other stakeholders [133], composing or slicing FMs [22, 109, 110], relating FMs to other artefacts (e.g., models) [62, 63, 76, 102], or generating other artefacts from FMs [72].

7.2.2 Ontologic-aware FM Synthesis Problem

The development of an ontologic-aware FM synthesis procedure raises new challenges that have been overlooked so far.

FM synthesis problem. Given a set of features' names and boolean dependencies among features, the problem is to synthesize a maximal and sound FM conforming to the configuration semantics. Formally, let ϕ be a propositional formula in conjunctive or disjunctive normal form. A synthesis function takes as input ϕ and computes an FM such that \mathcal{F} is equal to the boolean variables of ϕ and $\llbracket FM \rrbracket \equiv \llbracket \phi \rrbracket$. There are cases in which the diagrammatic part of an FM is not sufficient to express $\llbracket \phi \rrbracket$ (i.e., $\llbracket FD \rrbracket \subset \llbracket \phi \rrbracket$). It is thus required that the diagrammatic part is *maximal* (a comprehensive formalization is given in [29]). Intuitively, as much logical information as possible is represented in the diagram itself, without resorting to the constraints. Further details about the FM synthesis problem can be found in Section 3.2, page 26.

Ontologic-aware FM synthesis. The problem tackled in this chapter is a generalization of the FM synthesis problem. Numerous FMs, yet maximal, can actually represent the exact same set of configurations, out of which numerous present a naive hierarchical or grouping organization that mislead the ontological semantics of features and their relationships (e.g., see Figure 7.1b *versus* Figure 7.2a). We seek to develop an automated procedure that computes a well-formed FM both *i*) conformant to the configuration semantics (as expressed by the logical dependencies of a formula ϕ) and *ii*) exhibiting an appropriate ontological semantics.

The ontologic-aware synthesis problem not only arises when reverse engineering FMs. It is also apparent when *refactoring* an FM, i.e., producing an FM with the same configuration semantics but with a different ontological semantics. For example, the FM of Figure 7.2a could be refactored to enhance its quality and make it exploitable. The operation of *slicing* an FM has numerous practical applications (decomposition of a configuration process in multi-steps, reduction of the variability space to test an SPL, reconciliation of variability views, etc.) [22]. Despite some basic heuristics, we observed that the retained hierarchy and feature groups can be inappropriate [18] (the same observation applies for the *merge* and *diff* operators). The ontological aspect of an FM impacts all these automated operations since they are instances of the FM synthesis problem (see Figure 7.3, page 73).

7.3 Automated Techniques for Feature Hierarchy Selection

In [18], Acher *et al.* empirically showed that once the feature hierarchy is defined, the variability information of the FM can be fully synthesized in the vast majority of cases. That is, given the knowledge of the hierarchy, synthesis techniques can produce feature groups (Mutex-, Xor-, Or-groups), mandatory and optional relationships, as well as equals, implies and excludes constraints. We thus focus on the challenge of selecting a hierarchy in the remainder of this section. For this purpose, three types of techniques can be considered: logical, ontological and hybrid (a combination thereof).

Before going into details, we first introduce a central structure – the so-called binary implication graph – all kinds of techniques exploit for selecting a sound hierarchy (see Section 7.3.1). We present how *logical heuristics* can further exploit the input formula and we highlight their limits (see Section 7.3.2). We then describe our *ontologic-aware FM synthesis procedure* which essentially relies on a series of heuristics to rank parent-child relationships (see Section 7.3.3) and compute

clusters of conceptually similar features (see Section 7.3.3). The ranking lists and clusters can be interactively reviewed and exploited by a user, and if needs be, an optimum branching algorithm can extract a complete hierarchy (see Figure 7.6, page 79). The ontological heuristics can be combined with logical heuristics, resulting in an *hybrid* solution (see Section 7.3.4).

7.3.1 Sound Selection of a Hierarchy

The feature hierarchy of an FM defines how features are ontologically related and also participate to the configuration semantics, since each feature logically implies its parent: $\forall(f_1, f_2) \in E, f_1 \Rightarrow f_2$. As a result, the candidate hierarchies, whose parent-child relationships violate the original constraints expressed by ϕ , can be eliminated upfront.

Example. The feature `Local` cannot be a child feature of `PostgreSQL` since no configuration expressed in Figure 7.1a authorizes such an implication.

We rely on the *Binary Implication Graph*¹ (BIG) of a formula (see Definition 10) to guide the selection of legal hierarchies. The BIG represents every implication between two variables (resp. features) of a formula (resp. FM), thus representing every possible parent-child relationships a legal hierarchy can have. As an illustration, Figure 7.4 depicts the BIG of the formula ϕ_g of Figure 7.1c.

Selecting a hierarchy now consists in selecting a set of the BIG's edges forming a rooted tree that contains all its vertices. Such a tree represents a *branching* of the graph (the counterpart of a spanning tree for undirected graphs). The selection over the BIG is *sound* and *complete* since every branching of the BIG is a possible hierarchy of the FM and every hierarchy is a branching of the BIG.

Definition 10 (Binary Implication Graph (BIG)). *A binary implication graph of a Boolean formula ϕ over \mathcal{F} is a directed graph (V_{imp}, E_{imp}) where $V_{imp} = \mathcal{F}$ and $E_{imp} = \{(f_i, f_j) \mid \phi \wedge f_i \Rightarrow f_j\}$.*

Now that we have a convenient data structure, which captures every possible hierarchy, the whole challenge consists in selecting the most meaningful one. The following sections present different types of techniques (logical, ontological and hybrid) for selecting the desired hierarchy.

7.3.2 Logical Heuristics

From logical constraints expressed by the input formula ϕ , we can compute three interesting logical structures (cliques, logical feature groups, reduced BIG). Heuristics can then operate over these structures for selecting a feature hierarchy.

Cliques

A first logical heuristic is to consider that features that always logically co-occur are likely to denote mandatory parent-child relationships. Co-occurring features are identified as cliques in the BIG and can be efficiently computed [29].

Example. The BIG of Figure 7.4 contains 3 cliques: $\{\text{Wiki, Storage, License}\}$, $\{\text{PostgreSQL, Proprietary License}\}$ and $\{\text{MySQL, Open Source}\}$. The first clique contain a feature (Wiki) which is indeed the parent of Storage and License (see Figure 7.1b).

Logical feature groups

All possible feature groups of ϕ can be automatically computed [29,30]. The computation of feature groups can be performed over the BIG or the reduced BIG that we present below.

Example. 30 MUTEX groups, 21 XOR groups and 1 OR group can be extracted from the formula in Figure 7.1c. Among these 52 groups, 4 represent the *Xor* groups contained in the reference FM of Figure 7.1b. If we promote these groups as parent-child relations in the hierarchy, it would remain only 5 out of 13 features without parents. At first glance, these groups seem promising. However, selecting these 4 groups among the 52 that are computed is challenging.

¹Definition 10 is exactly the definition of feature implication graph employed in [165]. In another context (simplification of conjunctive normal form formula), it should be noted that Heule *et al.* [108] use a different definition of binary implication graph than ours.

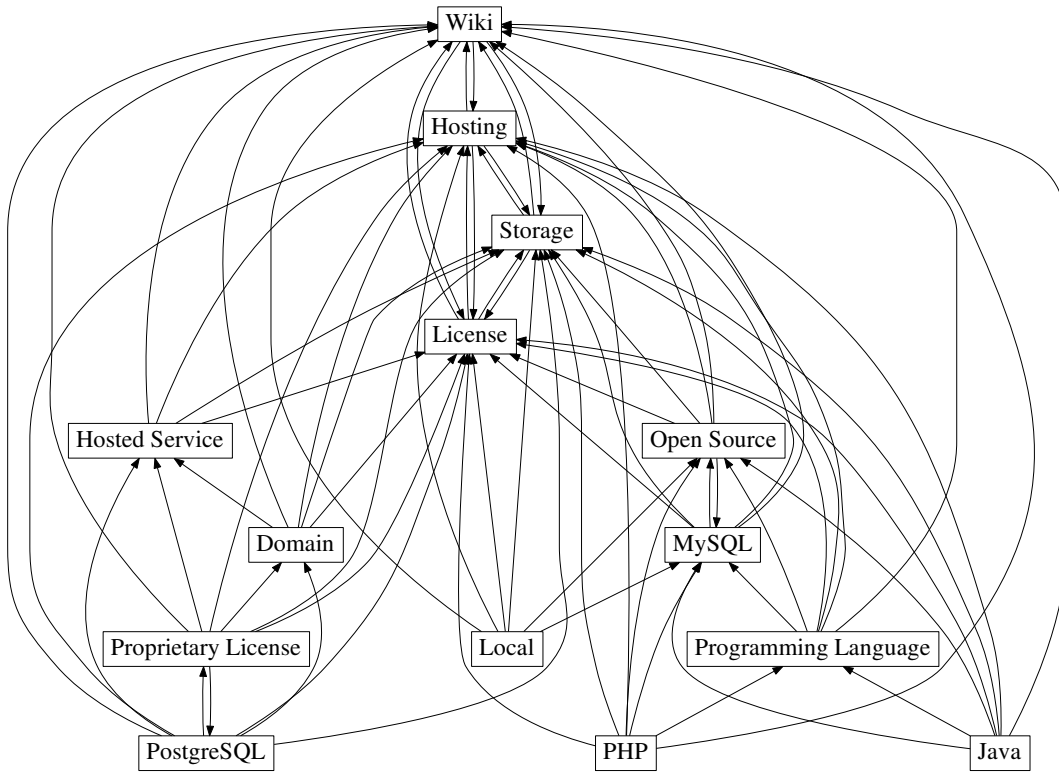

Figure 7.4: Binary implication graph of the formula in Figure 7.1b

Reduced BIG

Because of the transitivity of implication, a BIG is likely to have a large number of edges, out of which many candidates are not parent-child relationships. It is thus tempting to remove some edges of the BIG for reducing the complexity of the problem. A so-called *reduced BIG* is a subgraph of a BIG (see Definition 10) containing at least one tree that connects all the BIG's vertices, i.e., containing at least one valid hierarchy.

Different strategies can be developed to select the edges that can be removed from the BIG to get a reduced BIG. In our synthesis procedure, we adopted the following strategy. First, we contract each clique in one node, resulting in an acyclic graph. Then, we perform a transitive reduction. Finally, we expand the cliques.

The first step results in an acyclic graph in which the nodes are sets of features. Having an acyclic graph allows to compute a unique transitive reduction that is a subgraph of the BIG [26]. The transitive reduction maintains the reachability in the graph while removing edges.

Example. In Figure 7.4, Java is connected to MySQL with two paths: $\text{Java} \rightarrow \text{MySQL}$ and $\text{Java} \rightarrow \text{Programming Language} \rightarrow \text{MySQL}$. The edge $\text{Java} \rightarrow \text{MySQL}$ can be removed as the implication is already represented by the path through Programming Language.

The last step is necessary to get back to a graph with features as nodes. This ensures the compatibility with our algorithm on the complete BIG.

Example. After the transitive reduction, the clique $\{\text{PostgreSQL}, \text{Proprietary License}\}$ is connected to Domain. To expand the clique, we create a node for PostgreSQL and a node for Proprietary License. Then, we add the two following edges: $\text{PostgreSQL} \rightarrow \text{Domain}$ and $\text{Proprietary License} \rightarrow \text{Domain}$ to maintain the relations of the graph. Finally, we restore the edges $\text{PostgreSQL} \rightarrow \text{Proprietary License}$ and $\text{Proprietary License} \rightarrow \text{PostgreSQL}$ to represent the clique. Applying our strategy on the BIG of Figure 7.4 results in the graph in Figure 7.5. Our strategy significantly reduces the number of edges of this BIG from 71 to 37 edges.

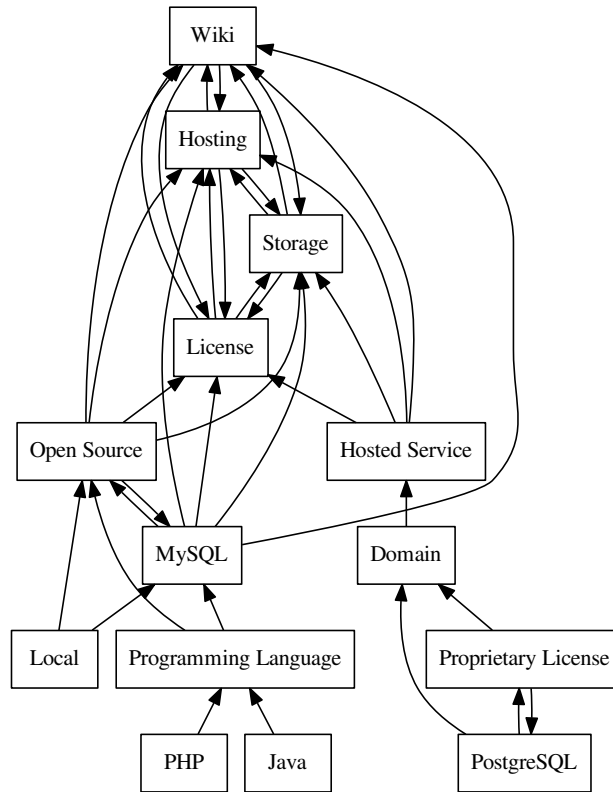

Figure 7.5: Reduced binary implicating graph of the graph in Figure 7.4

A reduced BIG can be used as a support for a sound synthesis, i.e., all represented hierarchies of the reduced BIG are conforming to the configuration semantics. However, a reduced BIG loses the property of completeness as it arbitrarily removes some hierarchies. Overall, it may be an efficient heuristic for reducing the complexity of the synthesis problem.

Potential Limits of Logical Techniques

We now present three techniques of the state-of-the-art that exploit the previous logical structures (BIG, reduced BIG, cliques and feature groups) to select an appropriate hierarchy. Then, we highlight their potential² limits regarding the ontologic-aware FM synthesis problem defined in Section 7.2.2.

A first basic approach, denoted $FMRAND_{BIG}$, is to randomly select a branching of the BIG. As stated in Section 7.3.1, every branching of the BIG is a possible hierarchy of the FM and conversely. Therefore, $FMRAND_{BIG}$ randomly select one of the possible hierarchies for the FM. A second approach, denoted $FMRAND_{RBIG}$, is to randomly select a branching over the *reduced* BIG instead of the complete BIG.

A third approach is proposed in [101]. Haslinger et al. proposed a technique (referred as FMFASE in the remainder of the chapter) that takes as input a set of products and fully generates an FM. The algorithm is iterative and essentially relies on logical structures exposed above: cliques are randomly unfolded, a reduced BIG is used to select parents, and feature groups (if any) are promoted.

FMFASE has three major drawbacks: (1) as reported in [101], the generated FM may not conform to the input configurations in the case of arbitrary constraints ; (2) the operations for computing

²The empirical study of the next section is precisely here to observe and quantify the limits in practical settings.

logical structures assume the enumeration of the complete set of product. It leads to an exponential blowup ; (3) feature names and ontological semantics are not considered during the synthesis.

The two first drawbacks – the lack of soundness and the performance issues – prompted us to re-develop their algorithm based this time on state-of-the-art satisfiability techniques [29]. We consider that the algorithm, called $\text{FMFASE}_{\text{SAT}}$ hereafter, is representative of a pure logical-based technique for fully synthesizing an FM.

Unawareness of Ontological Meaning. All these logical techniques share the third major drawback: ontological semantics is not considered during the synthesis. $\text{FMRAND}_{\text{BIG}}$ and $\text{FMRAND}_{\text{RBIG}}$ are ignoring any information about the features which can result in inappropriate hierarchies such as the one in Figure 7.2a. FMFASE and $\text{FMFASE}_{\text{SAT}}$ base their hierarchy selection on logical information which may not reflect actual ontological relations between features. *Example.* The features **Programming Language** and **PostgreSQL** can form a mutex group according to the formula in Figure 7.1c. Promoting this group as part of the hierarchy is valid from a logical point of view but it does not correspond to the desired hierarchy presented in Figure 7.1b.

Without exploiting ontological knowledge, it is unlikely that the synthesized FM will correspond to an appropriate ontological semantics. This third drawback is a motivation for the development of ontological heuristics which do consider the relations between the features.

7.3.3 Ontological Heuristics

As a reminder, the objective is to select the most appropriate hierarchy from the BIG which is a compact representation of all possible hierarchies of an FM. A first natural strategy is to add a weight on every edge (f_1, f_2) of the BIG, defining the probability of f_2 to be the parent of f_1 . The weights are computed by ontological heuristics that directly evaluate the probability of a relationship between a feature and a parent candidate. A *ranking list* of parent candidates for each feature can be extracted from the weighted BIG. From a user perspective, the ranking lists can be consulted and exploited to select or ignore a parent. In addition, we perform hierarchical *clustering* based on the similarity of the features to compute groups of features. The intuitive idea is that clusters can be exploited to identify *siblings* in the tree since members of the clusters are likely to share a common parent feature. For example, clusters can help tuning the previously computed weights, thus increasing the quality of the previous ranking lists. Moreover, users can operate over the clusters to define the parent of a group of features (instead of choosing a parent for every feature of a group).

Once we get the two pieces of information, we select the branching that has the maximum total weight. To compute an optimum branching, we use Tarjan’s algorithm [52, 170] whose complexity is $\mathcal{O}(m \log n)$ with n the number of vertices and m the number of edges. The hierarchy is then fed to synthesize a complete FM. The synthesis process is likely to be incremental and interactive ; users can validate and modify the ranking list and the set of clusters. The overall synthesis process is described in Figure 7.6.

Heuristics for Parent Candidates

The design of the ontological heuristics is guided by a simple observation: *parent-child relations in a hierarchy often represent a specialization or a composition of a concept (feature).*

Example. Java is a specialization of a Programming language while a Wiki is composed of a License, a Storage and a Programming Language.

As siblings are specializations or parts of the more general concept of their parent, they share the same context. Different kinds of relations (e.g., extension of the behavior of a parent feature) can be considered. The intuitive idea is that sharing the same context tends to make a feature semantically close to its parent and its siblings.

Example. Open source and Proprietary License are both referring to permissive rights about the use of a product.

From these observations, we developed several heuristics that exploit the feature names in order to compute the edges’ weights of the BIG. We can divide the heuristics in two categories: syntactical heuristics and semantical heuristics.

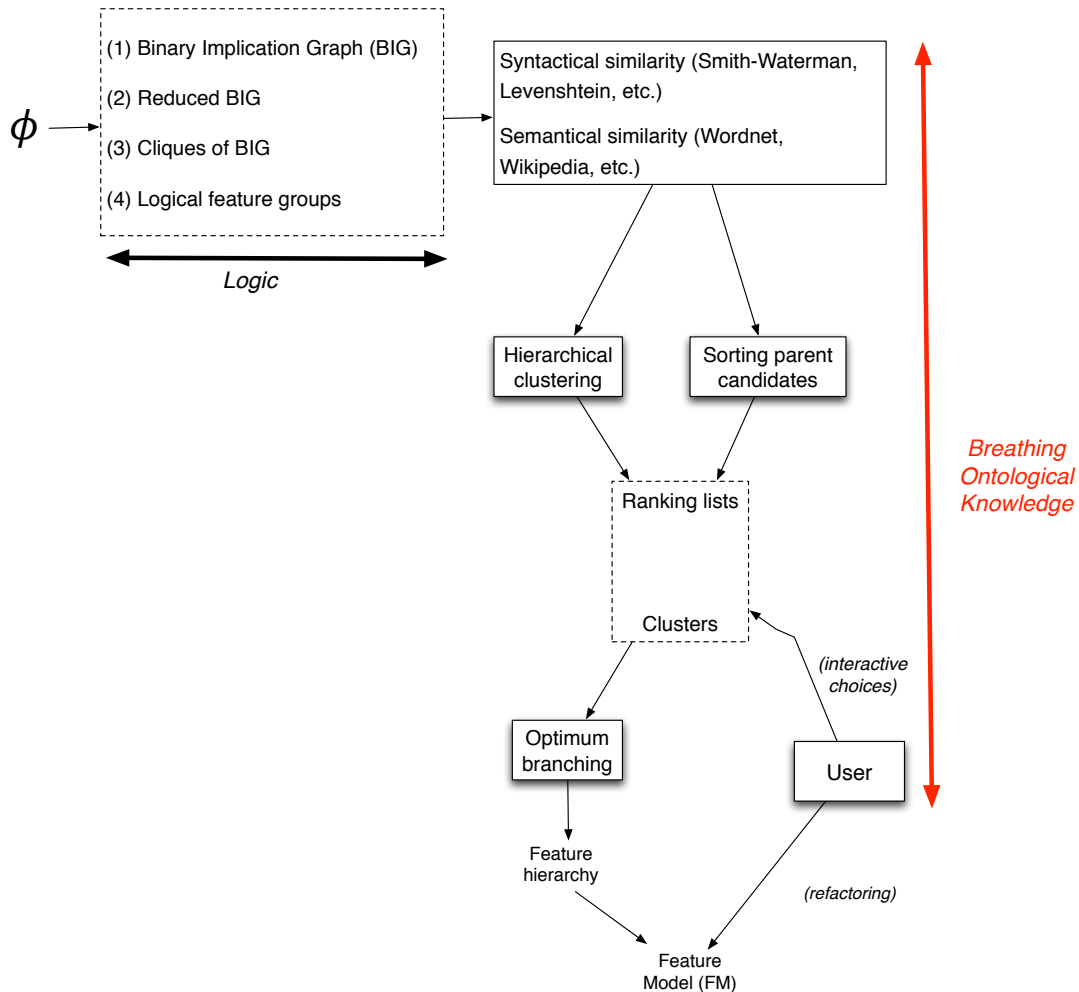

Figure 7.6: Ontologic-aware feature model synthesis

Syntactical heuristics use edit distance and other metrics based on words' morphology to determine the similarity of two features.

Example. In Figure 7.1b, *License* is closer to *Proprietary License* than *Storage* because the two first features contains the same substring: *License*.

We used *Smith-Waterman* [168] algorithm that looks for similar regions between two strings to determine their distance. We also used the so-called *Levenshtein* edit distance [182] that computes the minimal edit operations (renaming, deleting or inserting a symbol) required to transform the first string into the second one.

Semantical heuristics. Syntactical heuristics have some limits: feature names that are not syntactically close but semantically close (in the sense of meaning) are not identified, for example, *Java* and *PHP*. Thus, we need to add some semantical knowledge to improve our technique. We explored two general ontologies out of which we built semantical metrics.

First, we explored *WordNet* [134]. This is a structured English dictionary that provides hyperonymy (specialization) and meronymy (composition) relations between word senses. As we are exclusively using the features' names, we could not use the most efficient metrics based on a text corpus [49]. Such metrics would require more than the few words contained in the features' names. Therefore, we selected two metrics named *PathLength* and *Wu&Palmer* that are only based on WordNet's structure. The *PathLength* metric gives the inverse of the length of the shortest path between two words in WordNet considering only hyperonymy relations. Wu and Palmer described a metric based on the depth of the words and their lowest common ancestor in the tree formed by

hyperonymy relations [189].

These two metrics compute the similarity of two words, however features' name may contain several words. Wulf-Hadash et al. also used the *Wu&Palmer* metric in order to compute feature similarity [190]. We used the same formula for combining word similarity into sentence similarity:

$$Sim(f1, f2) = \frac{\sum_{i=1}^m \max_{j=1..n} wsim_{i,j} + \sum_{j=1}^n \max_{i=1..m} wsim_{i,j}}{m + n}$$

where m and n are respectively the number of words in $f1$ and $f2$ and $wsim_{i,j}$ is the similarity between the i -th word of $f1$ and the j -th word of $f2$.

WordNet contains few technical words, thus we explored *Wikipedia* to increase the number of recognized words. The well known encyclopedia offers a large database containing text articles and links between them. Associating a set of articles to a feature enables the use of techniques that compute semantic similarity of texts.

Example. We can associate the features `Java` and `Programming language` of the FM in Figure 7.1b to their respective articles in Wikipedia.

To search articles on Wikipedia and compare them, we use the work of Milne *et al.* [129, 136]. The authors provide a tool, called *WikipediaMiner*, that can extract a database from an offline dump of Wikipedia, search Wikipedia articles from the database and compare articles based on their hyperlinks³.

WikipediaMiner provides a model based on the hyperlink structure of Wikipedia that serves as a basis to compute the semantic similarity of two articles. In this model, an article is represented by a vector containing the occurrence of each link found in the article weighted by the probability of the link occurring in the entire Wikipedia database.

Our heuristics exploit *WikipediaMiner* API and databases to search articles with the closest title to a feature's name⁴. Then, it computes the semantic similarity of the features based on the similarity of the articles. The scores computed by *WikipediaMiner* are directly assigned to the relevant edges in the BIG. If no article is found, the heuristics simply assigns the minimal weight (i.e., 0) to the edges connected to the feature. It is important to note that the process is fully automated: users of such heuristic never have to manually search or compare Wikipedia articles.

Detecting Siblings with Hierarchical Clustering

Defining weights on the BIG's edges and computing the optimum branching can be summarized as choosing the best parent for a feature. However, it is sometimes easier to detect that a group of features are siblings. To detect such siblings we reuse the heuristics of the previous section (*Smith-Waterman*, *Levenshtein*, *PathLength*, *Wu&Palmer*, *Wikipedia* and *Wiktionary*).

We first compute the similarity between features without considering the BIG structure. Then, we perform agglomerative hierarchical clustering on these values. Agglomerative hierarchical clustering consists in putting each feature in a different cluster and merge the closest clusters according to their similarity. The merge operation is repeated until the distance between two clusters falls below a user specified threshold.

Finally, we use the BIG to determine if the clusters belongs to one of the two categories below. In the following, C represents a cluster and *possibleParents* gives the parent candidates according to the BIG.

- $\exists f_p \in \mathcal{F}, \forall f_c \in C, f_p \in \text{possibleParents}(f_c)$, i.e., all the features can be siblings. It remains to find a common parent of the cluster among the other features.
- $\exists P \subset C, \forall f_p \in P, \forall f_c \in C, f_p \neq f_c, f_p \in \text{possibleParents}(f_c)$, i.e., some features are parent of the others. It remains to find the parent among the features within the cluster.

³The extraction process is time-consuming (about 2 days on a single machine) and the extracted database contains approximatively 40GB of data. *WikipediaMiner* also provides an API to search and compare articles in the database.

⁴The heuristics based on *WikipediaMiner* do not guarantee that the most relevant article is retrieved. For instance, searching `Storage` in Wikipedia leads to a disambiguation page linking to different types of storage. Our current strategy is to arbitrarily choose a given definition. Asking the user to choose the most appropriate article can raise this limitation and is an interesting perspective to further improve the effectiveness of our heuristic.

In the two cases, the best parent is chosen according to heuristics for parent candidates.

Example. In Figure 7.1b, we determine with the Wikipedia heuristic that Java and PHP are semantically close, thus being in a same cluster. It corresponds to the first category exposed above. The key benefit is that we can now solely focus on their common parents – we can automatically compute them using the BIG. The best parent among the common parents corresponds here to Programming Language.

Clusters and Optimum Branching. Once we have defined the parents of the clusters, we modify the edges' weights of the BIG to consider this new information during the optimum branching algorithm. This modification consists in setting the maximal weight to each edge between a child and its chosen parent. The rationale is that features of the clusters are likely to share the same parent, thus the idea of augmenting the weights.

Example. We assign the maximum weight (i.e., 1) for the following BIG's edges: Java \rightarrow Programming Language and PHP \rightarrow Programming Language.

7.3.4 Logic + Ontologic = Hybrid

Ontological heuristics allows to synthesize an FM that have both a correct configuration semantics and an appropriate ontological semantics. However, the complexity of the BIG may disturb this type of heuristics and limit their benefits. Instead of operating over the BIG, other logical structures obtained from ϕ can be considered when applying ontological heuristics (see left part of Figure 7.6). This mix of ontological and logical heuristics is what we call a hybrid heuristic. It exploits logical information to reduce the complexity of the problem and then select an appropriate hierarchy based on ontological information.

We propose a hybrid approach called FMONTO_{LOGIC} in the remainder. The ontological heuristics we develop in Section 7.4.1 operate this time over the reduced BIG (instead of the BIG itself). As explained in Section 7.3.2, this structure significantly reduces the number of parent candidates and clusters; the drawback is that some hierarchies are no longer represented.

Example. In the complete BIG (see Figure 7.4), the feature Java has 7 parent candidates. In the reduced BIG (see Figure 7.5), the same feature Java is this time directly in relation with the correct parent Programming Language. On the other hand, the loss of completeness can prevent the selection of some desired hierarchies, e.g., PostgreSQL is not anymore in relation with its parent Storage after the reduction of the BIG (see Figure 7.5).

7.4 Tool Support

We implement and integrate all previous automated techniques into WebFML, a Web-based environment for managing FMs [7]. A unique feature of WebFML is its interactive support for choosing a *sound* and *meaningful* hierarchy. Ranking lists, clusters, cliques, and other facilities (graphical preview, undo/redo, etc.) are all integrated into WebFML to guide users in the choice of a relevant hierarchy among the numerous possibilities.

WebFML is built on top of FAMILIAR [87] and provides FM management operations all based on the synthesis procedure. Likewise practitioners can envision the use of WebFML in practical scenarios: the merging of multiple product lines [23]; the slicing of a configuration process into different steps or tasks [109]; the sound refactoring of FMs [18], especially when fully automated techniques produce incorrect FMs; the reverse engineering of configurable systems through the combined use of composition, decomposition and refactoring operators [14, 19].

WebFML also aims to ease the mechanical translation of artefacts with variability into FMs. It enables practitioners (e.g., product line managers, software developers) to reduce their effort and avoid accidental complexity when (re)-engineering or maintaining their variability models. In a nutshell, WebFML is a comprehensive environment for synthesizing FMs from various kinds of artefacts:

- *product comparison matrices*: by giving a specific interpretation of their semantics, a class of these matrices can be interpreted as FMs;

- *dependency graph* which can be extracted from configuration files of build systems (e.g. *pom.xml* files in Maven) [14, 19];
- *compilation directives and source code* in which features and their dependencies can be mined in order to synthesize an FM [29, 165].
- *propositional formula* in conjunctive or disjunctive normal form [18, 29, 162];
- *a (set of) FMs*: slicing, merging or refactoring existing FMs are instances of the synthesis problem we are addressing with WebFML [18, 23, 109].

7.4.1 Implementation of Ontological Heuristics

As part of WebFML we implemented six ontological heuristics (see Section 7.3) based on specialized libraries:

- The syntactical heuristics, *Smith-Waterman* (SW) and *Levenshtein* (L), come from the Simmetrics library⁵;
- *PathLength* (PL) and *Wu&Palmer* (WP) rely on extJWNL⁶ which handles the communication between WordNet and our tool.
- Wikipedia Miner [136] offers an API to browse Wikipedia's articles offline and compute their relatedness [135]. We used this tool on the english version of *Wikipedia* (Wiki) and *Wiktionary* (Wikt) which form the last two heuristics.

7.4.2 Features of the environment

WebFML offers an interactive mode where the user can import a formula (e.g., in DIMACS format), synthesizes a complete FM and export the result in different formats. During the FM synthesis, the graphical user interface displays a ranking list of parent candidates for every feature, a list of clusters, a list of cliques and a graphical preview of the FM under construction (see Figure 7.7, (E), (F), (G) and (H)).

During the interactive process, users can:

- select or ignore a parent candidate in the ranking lists (see Figure 7.7, (F));
- select a parent for a cluster within the cluster's features or any potential parent feature outside the cluster (see Figure 7.7, (G)). The user can also consider a subset of a cluster when selecting the parent;
- select a parent for a clique with the same interaction as clusters (see Figure 7.7, (H)).
- undo a previous choice (see Figure 7.7, (C));
- define the different heuristics and parameters of the synthesis (see Figure 7.7, (B));
- automatically generate a complete FM according to previous choices and selected heuristics (see Figure 7.7, (C));
- use FAMILIAR capabilities within an integrated console (see Figure 7.7, (I));
- manage FAMILIAR script files and previously computed variables (see Figure 7.7, (A) and (D)).

A typical usage is to perform some choices, generate a complete FM with the heuristics and reiterate until having a satisfactory model. At any moment, the optimum branching algorithm can synthesize a complete FM.

⁵<http://sourceforge.net/projects/simmetrics>

⁶<http://extjwnl.sourceforge.net>

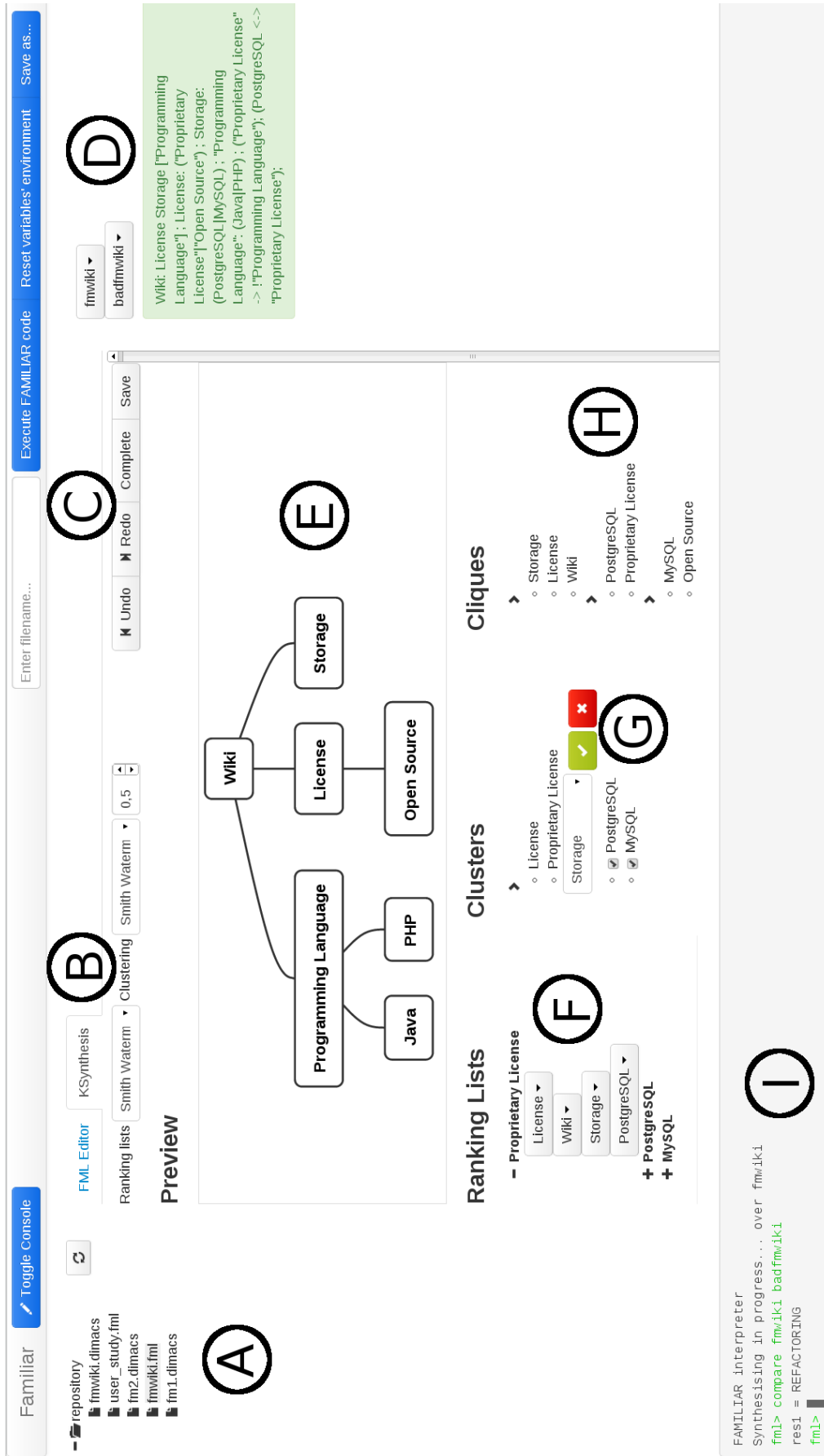

Figure 7.7: Interface of the environment during synthesis

7.4.3 Interactive edits of parent candidates and clusters

The ranking lists of parent candidates and the clusters form the main information during the synthesis. As the amount of information can be overwhelming, we propose a tree explorer view for manipulating and visualizing both parent candidates and clusters (see Figure 7.7, (F), (G) and (H)). A tree explorer view is scalable: it allows to focus on specific features or clusters while the other information in the explorer can be hidden.

During the synthesis, the user interacts almost exclusively by clicking on the elements of these explorers. Clicking on a feature in parent candidate lists allows to select or ignore a parent candidate. Users can also click on a cluster to choose a parent among the common parent candidates of the sibling features (see Figure 7.7, (C)). If the cluster contains the desired parent, the user can click on the feature and select the children within the cluster. In both cases, the user can deselect some features to consider only a subset of the cluster. The same behaviour applies to cliques.

We also propose a *graphical preview* of the FM based on Dagre⁷ and D3⁸ javascript libraries. It allows to summarize the previous choices and have a global view of the current result (see Figure 7.7, (E)).

7.5 Evaluation

So far, we have presented a sound procedure and various automated techniques, integrated into the WebFML environment, for synthesizing FMs. In this section we empirically investigate which heuristics presented in Section 7.3 are the best for breathing ontological knowledge. We conduct a series of experiments on 156 realistic FMs (see Section 7.5.1 for more details). Given an encoding of an FM fm_t as a formula, we evaluate the ability of the different synthesis techniques at selecting a feature hierarchy as close as possible to the original hierarchy of fm_t . Specifically we aim at answering the following research questions:

- **RQ1:** How effective are the techniques to fully synthesize an FM? Is a fully automated synthesis feasible? The effectiveness corresponds to the percentage of parent-child relations that are correctly synthesized with respect to the ground truth. When the whole synthesis process is performed in a single step, without any user intervention, the resulting FM may be far from the ground truth. This question aims at quantifying this potential effect.
- **RQ2:** How effective are techniques to compute ranking lists and clusters? For ranking lists, the effectiveness corresponds to the percentage of parents from the ground truth that are in the top 2 positions of the lists. For clusters, it corresponds to the percentage of correct clusters (*i.e.* clusters that exist in the ground truth) and the percentage of features that correct clusters represent in the ground truth FM. Selecting the most likely parents and siblings of a given feature can significantly reduce the number of choices a user has to perform during the interactive selection of a feature hierarchy. Is the reduction of the BIG a good heuristic? Are logical structures like cliques and feature groups good clusters? Do ontological heuristics help?

For each of the research question, we compare logical, ontological and hybrid-based techniques exposed in Section 7.3. We explore the possible role of the reduced BIG, cliques and logical feature groups for improving the synthesis – "as such" or as a complement to ontological techniques.

7.5.1 Experimental Settings

FM synthesis techniques under evaluation

Table 7.1 summarizes the available techniques and when they can be applied (e.g., FMFASE does not compute ranking lists or clusters and thus cannot address **RQ2**). FMONTO denotes the synthesis technique that relies on one of the six ontological heuristics over the BIG for computing the full

⁷<https://github.com/cpetttitt/dagre>

⁸<http://d3js.org/>

Technique	Logical/ontological	Research questions
FMFASE	Logical over reduced BIG, cliques, feature groups	RQ1
FMFASE _{SAT}	Logical over reduced BIG, cliques, feature groups	RQ1
FMRAND _{BIG}	Randomization over BIG	RQ1 and RQ2
FMRAND _{RBIG}	Randomization over reduced BIG	RQ1 and RQ2
FMONTO	Ontological over BIG	RQ1 and RQ2
FMONTO _{LOGIC}	Hybrid (Ontological over reduced BIG)	RQ1 and RQ2

Table 7.1: Synthesis techniques used for the experiments

Dataset	# features	# edges in the BIG	# edges in the reduced BIG	Depth of hierarchy
SPLIT (126 FMs)	17.6 (min 10, max 56)	131.7	54.8	3.8
PCM (30 FMs)	72.4 (min 23, max 177)	580.5	316.6	4.0

Table 7.2: Properties of FMs (average per FM)

FM, the ranking lists and clusters. As a reminder, the abbreviations used in the evaluation for the different ontological heuristics of FMONTO and FMONTO_{LOGIC} are mentioned in Section 7.4.1.

For FMFASE, we use the binary provided by the authors [27]. To reduce fluctuations caused by random generation [35], we run 1000 iterations for FMRAND_{BIG} and FMRAND_{RBIG} each time these heuristics are involved. The results are reported as the mean value over 1000 iterations.

Data

Our experiments operate over two datasets. We translate the configuration semantics of each FM of the datasets into a Boolean formula ϕ . The formula serves as input for our empirical evaluation procedure. The original hierarchy and feature groups of the FMs constitute the *ground truth* to evaluate the ontological quality of the different algorithms and heuristics.

SPLIT dataset. The SPLIT [169] public repository offers a large set of FMs from different domains created by academics or practitioners. From this repository, we manually selected FMs that are written in English and contain meaningful feature names⁹. This resulted in 201 FMs with a total of 5023 features. Due to memory consumption issues [101] and technical issues, 75 FMs from the SPLIT data set could not be handled by FMFASE. Therefore, we performed the experiment on the remaining 126 FMs that represent 2214 features.

Overall, the dataset is similar to the one used in [101] which was also extracted from SPLIT, authorizing a fair comparison with FMFASE.

PCM dataset. We gathered 30 FMs with an automated extraction process – in the same vein as the one described in [21] – from PCMs of Wikipedia. Each configuration of the extracted FM corresponds to at least one product of the PCM. The structure of the matrix and the Wikipedia pages (sections, headers, etc.) is exploited to produce hierarchies. Cell values (plain text values, "yes" value, "no" value, etc.) are interpreted in terms of variability.

We exploit the structure of the matrices as follows. In a PCM, there are values in each column and headers for characterizing a column. For example, the values MacOS X, Windows 7, or Ubuntu are values of a column whose header name is **Operating System**. We use the following strategy for deriving a hierarchy: values and headers are features; values are located below the header. In the example, MacOS X, Windows 7, or Ubuntu would be features of **Operating System** in a feature hierarchy. The overall structure of a Wikipedia page was created by domain experts (Wikipedia contributors) for organizing features of a set of product. The dataset is challenging for the synthesis procedures since the number of cross-tree constraints and the number of features are rather important, feature names are disparate, and the depth of the hierarchies is 4 in average.

Table 7.2 presents some statistics about the FMs. As an indication of the complexity of the synthesis process, we compute the number of parent candidates for each feature from the BIG of an

⁹Essentially we remove FMs with nonsense feature names like F1 or FT22 or written in Spanish. We did not discard FMs containing feature names not recognized by our ontologies.

FM. We have an average of 6.3 (from 0 to 36) parent candidates in SPLOT FMs and 8.3 (from 1 to 86) for PCM FMs. We also compute the average number of character contained in feature names of the input formula. The average is 11 characters per name for SPLOT FMs and 18 for PCM FMs. With so little information for the ontological heuristics used in FMONTO and FMONTO_{LOGIC}, the datasets are challenging and longer feature descriptions may improve the following results.

Method for Comparing the Evaluated Techniques

To answer our research questions, we compare the presented techniques according to a set of metrics that will be defined throughout the evaluation. To perform this comparison, we compute the *average* and the *median* of the metrics over the datasets.

We also run statistical tests to assess the significance of a difference between two techniques. When comparing two techniques, we measure the same metric on the same FMs, thus having paired samples. In this case, the most suitable tests are paired tests. A classic paired test is the t-test. However, this particular test requires that the data follows a normal distribution. To verify this assumption, we used the Shapiro-Wilk test. Most of these tests rejected (according to a threshold of 0.05 for the p-value) the hypothesis that the data is normal. Therefore, our experiments rely on the Wilcoxon rank-sum test, which does not assume a normal distribution of data. In our evaluation, the null hypothesis states that the two compared techniques have the same mean. The alternate hypothesis states that the means are different. Therefore, if we reject the null hypothesis, the difference between two techniques is significant but the direction of this difference is still unknown.

To complete the results of our tests, we also compute the effect size (*i.e.* how different are the results). In our case, we measure the effect size as the difference of the means of the two compared techniques. Using this definition allows an easy interpretation of the effect size in terms of the metric used. It also allows to know the direction of the difference between two heuristics.

In the following sections, the results of the statistical tests are reported according to a threshold of 0.05 for the p-value. For further details, all the p-values and effect sizes are reported in Appendix A.

7.5.2 RQ1: Fully Automated Synthesis

Our goal is to evaluate the effectiveness of a *fully* automated synthesis technique. The resulting synthesized FM should exhibit a feature hierarchy as close as possible to the original hierarchy of the ground truth. We consider that the more the number of common edges between the two hierarchies is, the more effective the technique is (see Definition 11).

Definition 11 (Effectiveness for a fully automated synthesis). *The effectiveness of an FM synthesis algorithm in a fully automated process is computed as follows:*

$$\text{effectiveness} = \frac{\text{commonEdges}(\text{synthesized FM}, \text{ground truth})}{|F| - 1}$$

commonEdges(synthesized FM, ground truth) represents the number of edges that are common between the hierarchy synthesized by the algorithm and the hierarchy from the ground truth. It corresponds to the number of correct parent-child relations according to the ground truth. $|F|$ is the number of features in the ground truth FM. As an FM hierarchy is a tree, $|F| - 1$ is the total number of parent-child relations.

For each input formula/set of configurations of the two data sets, we challenge all the techniques of Table 7.1 to fully synthesize an FM. In this experiment, we only use the ranking lists computed by the different techniques and we do not consider ontological or logical clusters.

Table 7.3 reports the percentage of common edges with the ground truth. We split the table in two, clearly separating (1) techniques that operate over the BIG (see Table 7.3a) from (2) techniques that apply a logical heuristic and operate over the reduced BIG (see Table 7.3b). There are two hypotheses behind this separation.

(H1) Ontological techniques are superior to random or logical heuristics when operating over the *same* logical structure.

H1 Results. In Table 7.3a all ontological heuristics (FMONTO) outperform FMRAND_{BIG}. For SPLOT, the best heuristic PathLength improves by 9.5% (average) and 10.6% (median) the effectiveness of FMRAND_{BIG}. Similar observations are made for the PCM dataset: the best heuristic Wikipedia improves by 10.4% (average) and 13.1% (median) the effectiveness of FMRAND_{BIG}.

Table 7.3b shows that almost all ontological heuristics (FMONTO) outperform FMFASE, FMFASE_{SAT} or FMRAND_{RBIG} being on SPLOT or PCM dataset. Only the Levenshtein heuristic is outperformed by FMFASE on SPLOT dataset and by FMRAND_{RBIG} on PCM dataset. However the improvement gained by ontological heuristics is less significant than in Table 7.3a. A possible reason is the use of the reduced BIG (see H2 below).

Statistical tests confirm that FMONTO significantly outperforms FMRAND_{BIG}, except for the Wu&Palmer heuristic on the PCM dataset and the Levenshtein heuristic on both datasets. For the results of FMONTO_{LOGIC}, 6 out of 30 statistical tests shows that it outperforms pure logical techniques (FMRAND_{RBIG}, FMFASE and FMFASE_{SAT}). The other tests cannot conclude that there is a significant difference with the results of the pure logical techniques.

Overall, we conclude that the hypothesis H1 is verified for the ontological techniques of FMONTO. We also note an improvement of hybrid techniques of FMONTO_{LOGIC} compared to pure logical techniques (FMRAND_{RBIG}, FMFASE and FMFASE_{SAT}). However, the tests cannot confirm that this difference is significant. This may be explained by the use of the reduced BIG. The next hypothesis address this question.

(H2) The reduced BIG can improve the effectiveness.

H2 Results. Results in Table 7.3a and Table 7.3b indicate that all techniques benefit from the reduction of the BIG. However the improvement is more apparent for FMRAND_{BIG}. Specifically FMRAND_{RBIG} increases by 24.1% (resp. 10.4%) the effectiveness of FMRAND_{BIG} in PCM dataset (resp. SPLOT dataset). Comparatively, the best improvement of FMONTO_{LOGIC} w.r.t. FMONTO is 21.8% (resp. 8.2%) in PCM dataset (resp. SPLOT dataset).

The reduction of the BIG significantly decreases the number of edges, thus favouring a random selection. For the SPLOT dataset, 56.1% (in average, 59.1% for the median) of the parent-child relations from the ground truth are kept after reduction of the BIG while more than half of the edges are removed. For PCM dataset, 83.8% (in average, 88.1% for the median) of the parent-child relations from the ground truth are kept after reduction of the BIG while almost half of the edges are removed. In practice the tradeoff between a reduction of the problem space and a less accurate representation clearly favours both FMONTO_{LOGIC} and FMRAND_{RBIG}.

If we compare the score of FMONTO in Table 7.3a with the scores of FMRAND_{RBIG}, FMFASE and FMFASE_{SAT} in Table 7.3b, we note that the purely logical techniques on the complete BIG outperform ontological techniques on the complete BIG. This is another important observation in favour of H2. Without the use of the reduced BIG, ontological heuristics are beat by randomized or logical-based heuristics, highlighting the prior importance of the logical structure. Finally, all the statistical tests confirm that H2 is verified.

Key findings for RQ1.

- A fully automated synthesis produces FMs far from the ground truth. At best, the percentage of correct parent-child relationships in the synthesized FM is 37.8% (for SPLOT) and 44.4% (for PCM); In practice the hybrid approach could provide a "by-default" visualisation of the FM but numerous faulty parent-child relationships (more than a half) need to be reviewed and corrected. Therefore it remains crucial to guide the users when refactoring the faulty FM or interactively selecting a feature hierarchy during the synthesis process.
- The experiment demonstrates that a hybrid approach provides the best support for fully synthesizing an FM. A key aspect is that the reduced BIG significantly improves the effectiveness of all techniques.

Table 7.3: Effectiveness of full synthesis (percentage of common edges)

(a) Full synthesis with BIG

Data set		Pure logical techniques	Ontological techniques (FMONTO)					
		FMRAND _{BIG}	SW	L	WP	PL	Wiki	Wikt
SPLOT	average	20.9	28.8	26.9	29.1	30.4	29.4	28.5
	median	16.7	24.0	21.8	27.3	27.3	26.5	27.3
PCM	average	15.9	24.0	19.4	20.8	23.2	26.3	22.7
	median	14.0	19.9	18.0	19.0	22.4	27.1	19.0

(b) Full synthesis with a reduced BIG (● means that the approach cannot be applied due to performance issues)

Data set		Pure logical techniques			Hybrid techniques (FMONTO _{LOGIC})					
		FMFASE	FMFASE _{SAT}	FMRAND _{RBIG}	SW	L	WP	PL	Wiki	Wikt
SPLOT	average	36.1	31.9	31.3	36.9	34.9	36.5	37.8	37.4	36.7
	median	35.8	25.0	27.3	32.7	30.8	32.2	36.2	33.9	33.3
PCM	average	●	39.9	40.0	43.1	39.8	42.6	43.6	44.4	42.2
	median	●	32.9	32.8	35.9	34.2	34.1	35.2	37.4	35.5

7.5.3 RQ2: Quality of ranking lists and clusters

Our goal is to evaluate the quality of the ranking lists and the clusters. We also evaluate the use of cliques and feature groups during the synthesis for selecting the hierarchy of an FM. In this experiment we do not consider FMFASE and FMFASE_{SAT} techniques as they do not provide such information.

Ranking lists

We consider that the ranking lists should place the original parent of the ground truth as close as possible to the top of the list. Specifically, we look at the *Top 2* positions of the lists and evaluate the effectiveness of a technique at computing ranking lists as defined in Definition 12. With an average of 6.3 parent candidates per feature in the SPLOT dataset, we chose to restrict our evaluation to the top 2 positions in order to reduce the impact of random choices. Indeed, it already allows a probability of almost 32% (in average) of having a correct parent for randomized approaches.

Definition 12 (Effectiveness for computing ranking lists). *The effectiveness of an FM synthesis algorithm for computing ranking lists is computed as follows:*

$$effectiveness = \frac{\# \text{ parents in top 2 positions}}{|F| - 1}$$

To compute the # parents in top 2 positions, we check that the parent of each feature (as it appears in the ground truth) appears in the top 2 positions of the ranking list. $|F| - 1$ represents the number of features that have a parent in the ground truth (i.e. all the features except the root).

Table 7.4 reports the percentage of correct parents in the Top 2 positions of the ranking lists. As in the previous experiment, we separate the techniques that operate over the BIG from the techniques that operate over the reduced BIG and pose the same two hypotheses as in RQ1.

(H3) Ontological techniques are superior to random heuristics when operating over the *same* logical structure.

H3 Results. In Table 7.4a, FMONTO outperforms FMRAND_{BIG}. For SPLOT FMs, the best heuristic PathLength improves by 10.2% (average) and 11.7% (median) the effectiveness of FMRAND_{BIG}. For the other dataset, the Wikipedia heuristic improves by 9.4% (average) and 10.6% (median) the effectiveness of FMRAND_{BIG}. The statistical tests confirm these results for the SPLOT dataset and for the Wikipedia heuristic on the PCM dataset. For the other heuristics, the tests cannot confirm that there is a significant difference between FMONTO and FMRAND_{BIG}.

Table 7.4: Percentage of correct parents in the top 2 positions of the ranking lists (RQ2)

(a) With BIG

Data set		Pure logical technique	Ontological techniques (FMONTO)					
		FMRAND _{BIG}	SW	L	WP	PL	Wiki	Wikt
SPLOT	average	43.0	50.0	49.5	51.6	53.2	51.4	50.2
	median	38.3	48.8	46.3	50.0	50.0	55.4	50.0
PCM	average	32.3	39.9	37.3	37.0	39.8	41.7	38.0
	median	28.9	37.2	35.8	34.5	40.0	39.5	34.0

(b) With reduced BIG

Data set		Pure logical technique	Hybrid techniques (FMONTO _{LOGIC})					
		FMRAND _{RBIG}	SW	L	WP	PL	Wiki	Wikt
SPLOT	average	51.6	56.4	55.6	57.1	58.9	57.1	56.5
	median	50.5	55.6	55.1	54.9	56.3	58.3	57.1
PCM	average	52.2	54.9	53.0	55.0	56.3	55.7	54.3
	median	46.5	53.5	47.7	52.9	55.0	55.9	53.6

Table 7.4b also shows that FMONTO_{LOGIC} outperforms FMRAND_{RBIG} on both data sets but the scores are significantly closer. The tests reflect this observation as they cannot confirm that a difference exists between FMONTO_{LOGIC} and FMRAND_{RBIG}, except for the PathLength heuristic on the SPLOT dataset.

Overall, we cannot conclude that the hypothesis **H3** is verified in all cases but the average and median scores indicate at least a slight improvement of the effectiveness of FMONTO (resp. FMONTO_{LOGIC}) compared to FMRAND_{BIG} (resp. FMRAND_{RBIG}).

(**H4**) The reduced BIG improves the quality of ranking lists.

H4 Results. The SPLOT dataset (resp. PCM dataset) results in a 5.7% (average) and 6.3% (median) (resp. 16.5% and 15%) improvement of the effectiveness of our best heuristic PathLength. FMRAND_{RBIG} also clearly benefits from the reduction of the BIG as it improves the effectiveness of FMRAND_{BIG} by 8.6% for SPLOT and 19.9% for PCM.

The statistical test confirms the results on the PCM dataset. However, on the SPLOT dataset, the difference is not significant for most of the heuristics. This may be explained by the 43.9% of correct parents brutally removed by the reduction in the SPLOT dataset. For the PCM dataset, the reduction of the BIG removes only 16.2% of correct parents.

As a result, the hypothesis **H4** is verified for the PCM dataset but the results for SPLOT shows that the reduced BIG may have a limited effect.

Clusters

We consider that the computed clusters should contain either sibling features from the ground truth or siblings with their corresponding parent – in line with the two cases identified in Section 7.3.3, page 80. For example in Figure 7.1b, page 70, {Hosted Service, Local} is a correct cluster because the two features are siblings. {Hosted Service, Local, Hosting} is also a correct cluster because Hosting is the parent of Hosted Service and Local. The effectiveness of a technique corresponds to the number of correct clusters and the percentage of features that these clusters represent (see Definition 13 for further details).

Definition 13. *The effectiveness of an FM synthesis algorithm for computing clusters is composed of two aspects:*

$$\text{Percentage of correct clusters} = \frac{\# \text{ correct clusters}}{\# \text{ clusters}}$$

$$\text{Percentage of features in a correct cluster} = \frac{\# \text{ features in correct clusters}}{|F|}$$

clusters represents the number of clusters that are generated by the algorithm. *# correct clusters* is the number of clusters that contain either sibling features from the ground truth or siblings with

their corresponding parent. # features in correct clusters is the sum of the correct clusters' sizes. Finally, $|F|$ represents the number of features in the ground truth.

Table 7.5 reports for each dataset, the number of clusters, the clusters' sizes, the percentage of correct clusters computed by the techniques, and the number of features in a correct cluster (in average and for the median). For each heuristic, we optimized¹⁰ the thresholds for the clustering in order to produce the largest number of features in a correct cluster. Intuitively, clusters allow the user to choose only one parent for a set of features. Maximizing the number of features in correct clusters potentially reduces the user effort. As previously, we separate our evaluation in two hypotheses.

(H5) Ontological techniques are superior to random heuristics when computing clusters over the same logical structure.

H5 Results. Table 7.5a shows that FMONTO generates less clusters per FM than FMRAND_{BIG}. However, FMONTO produces clusters that are slightly bigger and more accurate. For SPLOT, our best heuristic PathLength generates 67.6% (average) and 75% (median) of correct clusters while FMRAND_{BIG} reaches 27.7% (average) and 25% (median). The percentage of features in correct clusters is also significantly better than FMRAND_{BIG}. For the PCM dataset, the difference is greater with 79.2% (average) and 77.7% (median) of correct clusters for PathLength compared to only 14.9% (average) and 12.8% (median) for FMRAND_{BIG}. Table 7.5b also shows that FMONTO_{LOGIC} outperforms FMRAND_{RBIG} for all the results.

We observe that PathLength is the best heuristic according to the percentage of correct clusters whereas Levenshtein is the best one according to the percentage of features in a correct cluster. We also note that the Levenshtein heuristic produces more and bigger clusters than PathLength. These differences show that there is a tradeoff between the number of features contained in clusters and their accuracy. It corresponds to the classical tradeoff between precision and recall that will be further illustrated with the use of the reduced BIG in H6.

Statistical tests show that FMONTO (resp. FMONTO_{LOGIC}) outperforms FMRAND_{BIG} (resp. FMRAND_{RBIG}) on both datasets, except for Wu&Palmer and PathLength heuristics. It confirms the usefulness of ontological-based heuristics, whether they operate over a reduced BIG or a BIG and validates the hypothesis H5.

(H6) The reduced BIG improves the quality of the clusters.

H6 Results. Table 7.5b shows that the reduced BIG allows to produce less clusters per FM compared to the techniques operating over the complete BIG. The clusters are also slightly smaller. For SPLOT, 74.8% (average) and 100% (median) of clusters are correct with our best heuristic Wiktionary. For PCM, the PathLength heuristic produces 89.2% (average) and 89.6% (median) of correct clusters. Therefore, and for every ontological-based heuristics, the accuracy of the generated clusters increases when we reduce the BIG. The statistical tests confirm these results except for Wu&Palmer and PathLength heuristics on the SPLOT dataset despite their improvements.

However, the percentage of features in a correct cluster is slightly inferior compared to the results with a complete BIG. On a complete BIG (see Table 7.5a), our best heuristic Levenshtein produces 31% (average) and 30% (median) of correct clusters for SPLOT (resp. 41.4% and 41.2% for PCM). On a reduced BIG, Levenshtein produces 29.2% (average) and 29% (median) for SPLOT (resp. 41% and 41.2% for PCM). All the statistical tests are consistent with these observations as they cannot state that the difference is significant.

The results show that there is no clear superiority of an approach. The use of the reduced BIG or the use of the complete BIG when computing clusters have both pros and cons. On the one hand, the reduced BIG supports the identification of more accurate but less clusters with less features. On the other hand, the complete BIG provides more false positives but a user can consult and manipulate larger clusters. From a practical and tooling point of view, there is a classical tradeoff to find between precision and recall.

¹⁰The threshold values were manually determined. For each heuristic, we changed the threshold value by steps of 0.1 (all our heuristics return a value between 0 and 1) to maximize the average number of features in a correct cluster.

Table 7.5: Clusters generated by heuristics (RQ2)

(a) Clusters generated by FMRAND_{BIG} and FMONTO

Metric	Data set		Pure logical technique	Ontological techniques (FMONTO)					
			FMRAND _{BIG}	SW	L	WP	PL	Wiki	Wikt
Number of clusters	SPLOT	average	6.2	4.1	4.0	2.7	2.5	3.3	2.9
		median	5.0	4.0	3.5	2.0	2.0	3.0	3.0
	PCM	average	29.7	16.8	17.6	5.8	8.7	9.8	12.3
		median	25.0	15.5	14.5	5.0	7.0	8.0	9.5
Clusters'size	SPLOT	average	2.2	2.9	2.8	2.5	2.3	2.9	2.3
		median	2.1	2.7	2.5	2.3	2.2	2.7	2.0
	PCM	average	2.3	3.3	2.8	2.6	2.6	5.8	3.0
		median	2.3	3.1	2.8	2.5	2.4	5.1	2.8
Percentage of correct clusters	SPLOT	average	27.7	50.4	55.3	57.3	67.6	54.7	66.8
		median	25.0	50.0	50.0	50.0	75.0	50.0	69.0
	PCM	average	14.9	49.6	62.6	60.8	79.2	53.7	71.0
		median	12.8	47.3	65.5	64.6	77.7	57.1	66.7
Percentage of features in a correct cluster	SPLOT	average	18.9	29.0	31.0	19.5	21.8	25.7	24.5
		median	16.7	26.5	30.0	17.9	20.0	22.2	23.3
	PCM	average	12.5	35.0	41.4	12.9	22.8	24.5	32.2
		median	10.5	32.3	41.2	12.4	23.2	21.9	31.9

(b) Clusters generated by FMRAND_{RBIG} and FMONTO_{LOGIC}

Metric	Data set		Pure logical technique	Ontological techniques (FMONTO _{LOGIC})					
			FMRAND _{RBIG}	SW	L	WP	PL	Wiki	Wikt
Number of clusters	SPLOT	average	4.0	3.0	3.1	2.3	2.0	2.5	2.3
		median	4.0	3.0	3.0	2.0	2.0	2.0	2.0
	PCM	average	12.9	11.2	14.0	4.8	7.6	7.1	9.8
		median	12.0	10.0	13.0	5.0	6.5	6.0	9.0
Clusters'size	SPLOT	average	2.1	2.5	2.5	2.2	2.1	2.5	2.1
		median	2.0	2.3	2.4	2.0	2.0	2.5	2.0
	PCM	average	2.2	3.1	2.7	2.5	2.5	4.4	2.9
		median	2.2	2.7	2.8	2.4	2.3	3.8	2.7
Percentage of correct clusters	SPLOT	average	40.4	66.2	67.3	64.7	73.2	67.5	74.8
		median	33.3	66.7	75.0	66.7	100.0	75.0	100.0
	PCM	average	36.7	68.2	75.9	73.3	89.2	72.4	85.7
		median	28.6	71.4	82.7	76.4	89.6	80.0	89.4
Percentage of features in a correct cluster	SPLOT	average	17.9	26.6	29.2	18.7	19.8	23.8	22.4
		median	15.4	23.1	29.0	16.7	17.0	20.0	20.0
	PCM	average	12.3	34.6	41.0	12.8	22.7	24.2	32.2
		median	10.5	32.3	41.2	12.4	23.2	21.4	31.9

Using Cliques in FM Hierarchy Selection

Features that co-occur in configurations (i.e., cliques) can be efficiently computed using standard logical techniques [29]. We want to further understand how an FM synthesis algorithm can benefit from the use of cliques as a logical heuristic.

A first step is to identify the type of relations contained in cliques. For the SPLOT dataset (resp. the PCM dataset), we report that 93.8% (average) and 100% (median) of the cliques (resp. 98.9% and 100%) contain features that are connected to others by parent-child relationships. The remaining cliques are not subtrees of the hierarchy and contain at least one bi-implication cross-tree constraint. Therefore, cliques almost always represent parent-child relations between features.

From this observation, we consider cliques as a special kind of cluster. For example, FMFASE uses cliques as a cluster. It chooses one feature of a clique and places it as the parent of the others. This pattern is what we call a *simple unfolding*: users just have to select one feature in the clique that will play the role of parent feature of the others. For instance, the clique {Wiki, Storage, License, Hosting} is transformed through a simple unfolding in Figure 7.8a: Wiki is the parent of Storage, License and Hosting.

However, more *complex unfolding* may arise. Let us take a fictive example and consider that the feature Storage is below Hosting (and not Wiki as in the running example). In that case, the clique requires a complex unfolding that consists in defining several levels of features in the hierarchy (see Figure 7.8b for an example).

(a) Simple unfolding : one parent and one level of descendants

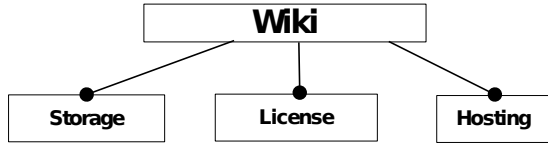

(b) Complex unfolding : one parent and several levels of descendants

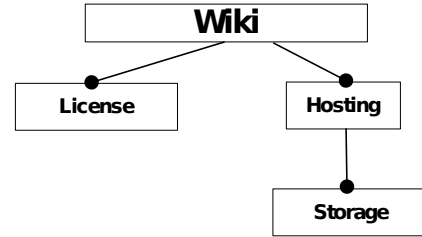

Figure 7.8: Clique unfolding: simple versus complex

Table 7.6: Cliques and logical feature groups as clusters

(a) With the BIG (● means that the clusters cannot be computed due to performance issues)

Metric	Data set		Cliques	Feature groups			
				All groups	Mutex	Xor	Or
Number of clusters	SPLOT	average	1.6	9.5	2.8	5.9	1.3
		median	1.0	3.0	0.0	1.0	1.0
	PCM	average	1.4	55.7	45.2	17.8	●
		median	1.0	8.0	7.5	1.0	●
Clusters'size	SPLOT	average	5.0	2.2	1.2	1.6	1.8
		median	4.0	2.3	0.0	2.0	2.0
	PCM	average	7.0	5.7	5.6	5.4	●
		median	6.0	5.0	4.5	5.0	●
Percentage of correct clusters	SPLOT	average	50.0	69.3	41.7	89.1	72.9
		median	50.0	75.0	33.3	100.0	100.0
	PCM	average	31.1	92.2	91.5	91.1	●
		median	0.0	100.0	100.0	100.0	●
Percentage of features in a correct cluster	SPLOT	average	17.5	36.3	5.8	21.9	13.2
		median	15.4	35.0	0.0	16.0	8.9
	PCM	average	3.3	60.7	53.2	15.6	●
		median	0.0	60.7	53.1	12.2	●

(b) With the feature graph (reduced BIG)

Metric	Data set		Feature groups			
			All groups	Mutex	Xor	Or
Number of clusters	SPLOT	average	3.7	0.4	2.0	1.3
		median	2.0	0.0	1.0	1.0
	PCM	average	10.4	8.4	2.0	●
		median	8.0	5.0	1.0	●
Clusters'size	SPLOT	average	2.2	0.5	1.4	1.8
		median	2.3	0.0	2.0	2.0
	PCM	average	5.9	5.3	5.8	●
		median	5.0	3.9	5.0	●
Percentage of correct clusters	SPLOT	average	80.0	69.0	92.1	72.9
		median	100.0	100.0	100.0	100.0
	PCM	average	100.0	100.0	100.0	●
		median	100.0	100.0	100.0	●
Percentage of features in a correct cluster	SPLOT	average	32.6	2.6	16.7	13.2
		median	33.3	0.0	13.6	8.9
	PCM	average	64.3	46.0	18.3	●
		median	60.7	40.7	14.0	●

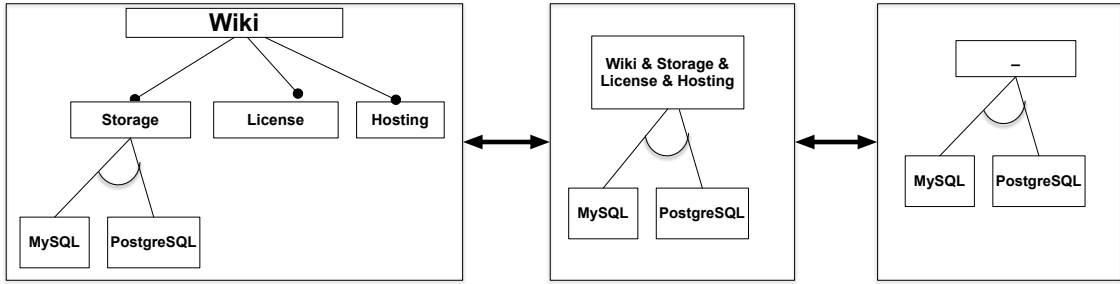

Figure 7.9: Logical feature groups: bi-implied features, clique contraction, parent place-holder

We evaluate the use of cliques as clusters with the same metrics used in Section 7.5.3. Table 7.6a presents the results. We observe that simple unfolding (*i.e.* a correct cluster) is required in 50% (average) and 50% (median) of the cliques of SPLOT FMs. For PCM FMs, this pattern represents 31.1% (average) and 0% (median) of the cliques. In at least half of the cases, cliques require more user effort than a traditional cluster in which only one parent should be selected (*i.e.* it requires a complex unfolding). Therefore, a simple unfolding can be used as a default heuristic for selecting parent-child relations in a clique but not as a reliable heuristic in a fully automated synthesis.

Using Logical Feature Groups in FM Hierarchy Selection

In addition to cliques, logical feature groups can be exploited during the selection of the FM hierarchy. All *possible* logical feature groups of a formula can be computed either using the reduced BIG [29] or the BIG. A logical feature group consists in a set of sibling features and a parent feature. It is in line with the definition of cluster given in Section 7.3.3. We study here how the so-called *logical feature groups* are interesting structures for representing clusters.

Computing feature groups from a formula may lead to numerous groups containing the same set of sibling features but with different parents. This is due to feature groups in which the parent is logically bi-implied by another feature (*i.e.*, the parent feature belongs to a clique). An example is given in Figure 7.9. To avoid this combinatorial explosion, we omit the parents and consider only the sibling features. We introduce a place-holder that can be one of the parent of the siblings (see right of Figure 7.9). This factoring strategy has the merit of presenting to users only one cluster, abstracting numerous other clusters. For the experiment, we verified whether logical feature groups are correct clusters – in line with the definition of Section 7.5.3, page 89.

Table 7.6a shows the results. For SPLOT FMs, 69.3% (average) and 75% (median) of logical feature groups are correct clusters. These results are slightly superior to the 67.6% (average) and 75% (median) of correct clusters generated by our best heuristic PathLength (see Table 7.5a).

For PCM FMs, 92.2% (average) and 100% (median) of feature groups are correct clusters. It outperforms the 79.2% (average) and 77.7% (median) of correct clusters from our best heuristic PathLength.

However, we note that 473 Xor-groups were generated from a unique FM and 36 only were correct clusters. This extreme example shows that, in some cases, logical feature groups may challenge an automated technique or overwhelm a user with numerous incorrect clusters.

(H7) The reduced BIG can improve the quality of logical feature groups.

H7 Results. Table 7.6b shows the same metrics than Table 7.6a but for feature groups computed from the reduced BIG of the FM. We note that reducing the BIG significantly reduces the number of computed feature groups. Also, their accuracy increases compared to the groups in Table 7.6a but the correct groups often involve less features. Statistical tests show that the percentage of correct clusters is significantly better when using a reduced BIG. However, the difference in the percentage of features in a correct cluster is not stated as significant. Moreover, the test for the Mutex groups on the SPLOT dataset shows a significant decrease of the metric. Therefore, the test cannot verify H7 but they illustrate the tradeoff between precision and recall when computing clusters which is consistent with the results of H6.

Key findings for RQ2.

- The experiment demonstrates that an approach based on ontological heuristics provides the best support for producing ranking lists. At best, the user has to review only 2 parent candidates for 58.9% of the features (for SPLOT) and 56.3% (for PCM);
- An approach based on the reduced BIG does not necessarily improve the quality of the ranking lists or clusters;
- Ontological heuristics are beneficial to ranking lists. Ontological heuristics also generate less clusters than $FMRAND_{BIG}$ but they are far more accurate;
- Among the ontological heuristics, there is no clear winner – even if all are beneficial for breathing ontological knowledge;
- In 93.8% (resp. 98.9%) of the cases, all features of the cliques are connected by parent-child relationships to at least one feature. Nevertheless cliques require complex unfolding in more than 50% of the cases;
- Logical feature groups form accurate clusters especially when they are computed over the reduced BIG. The place-holder for factoring out similar feature groups makes the difference. Yet there are extreme cases in which lots of logical feature groups do not correspond to clusters.

7.5.4 Summary and Discussion

Eventually a combined use of techniques, that is, a hybrid approach empirically emerges:

- Ontological heuristics with reduced BIG are the best suited for a one-step full synthesis of FM (see **RQ1**);
- Ontological heuristics over the reduced BIG are the best suited for computing ranking lists (see **RQ2**);
- Logical feature groups with place-holders and computed over the reduced BIG are the most accurate clusters (see **RQ2**);
- Cliques and clusters obtained with ontological heuristics can complete the information presented to users (see **RQ2**).

The empirical results impact feature modeling tools (e.g., WebFML) and call for more investigations in terms of user experience.

As part of WebFML we have integrated *default* synthesis heuristics for (1) one-step full synthesis, (2) ranking lists and (3) clusters. We choose the most suited heuristics according to the empirical results. We now discuss our choices, some tradeoffs, and practical implications of the experiments.

For *one-step full synthesis*, we select *PathLength* with the reduced BIG as the default heuristic (*PathLength* gives the best results for the SPLOT dataset). All heuristics operating over the BIG are inferior to *PathLength* and are not included in WebFML. Statistical tests show no clear superiority of *PathLength* over other ontological heuristics with the reduced BIG or FMFASE. The choice of *PathLength* can thus be replaced by another heuristic (WebFML allows users to choose a specific heuristic).

More importantly, the empirical results show that one-step full synthesis is far from the ground truth. Two attitudes are possible for a user. The first is to *refactor* the synthesized FM and fix the erroneous relations between features. The second is to *not* use a one-step full synthesis. In any case, a crucial feature of WebFML is the ability to provide an interactive support for users (see hereafter).

For the computation of *ranking lists*, *PathLength* and *Wikipedia* heuristics outperform the other heuristics of FMONTO and FMONTO_{LOGIC}. The two heuristics have very similar results. In WebFML,

we choose *PathLength* as the default heuristic. The reason of this choice instead of *Wikipedia* is only technical. The *Wikipedia* heuristic requires a large database (40GB) which makes the deployment harder than with a WordNet based heuristic.

For the computation of *clusters*, two ontological heuristics stand out and have interesting properties: *PathLength* and *Levenshtein*. Yet the choice of a default heuristic requires to consider some tradeoffs. On the one hand, *PathLength* is the most accurate heuristic. On the other hand, the correct clusters produced by *Levenshtein* cover more features. In practice, a user of WebFML needs to review less clusters with *PathLength* but the part of the hierarchy that could be synthesized from these clusters is smaller. Conversely, using *Levenshtein* forces the user to review more clusters but the induced benefit can be more important.

The tradeoff between the number of clusters to review and the accuracy of the heuristics needs to be addressed in a usability study. Currently, *Levenshtein* is the default heuristic retained for computing clusters in WebFML. WebFML does not present logical feature groups by *default*, considering they may overwhelm users with lots of false clusters. Nevertheless users can depict them on demand, typically when choices have already been made and the number of clusters is becoming lower. More generally, users can change heuristics for clusters if needs be and WebFML provides facilities to manage clusters (e.g., non relevant clusters can be removed).

Summary. Ranking lists, logical feature groups, cliques, clusters with ontological heuristics: all are potentially useful for the synthesis; and the better they are, the better it is for users. Based on empirical results, WebFML integrates state-of-the-art techniques and provides advanced facilities for manipulating the information (e.g., unfolding of cliques). Now the overall challenge is to make all these structures visible into an environment – without overwhelming and distracting the user with extraneous or redundant information. The *usability* aspects of an FM synthesis environment like WebFML deserve a focused and careful attention. We leave it as future work.

7.6 Threats to Validity

7.6.1 External Validity

Threats to *external validity* are conditions that limit our ability to generalize the synthesis results to other forms of dependencies or feature names. A first concern is whether FMs are representative of practice. We use the SPLOT public repository [169]. SPLOT is a common benchmark for the FM community (see, e.g., [18, 29, 100, 101, 132, 146, 147, 157, 191]) and is considered to manage "realistic" examples by several authors. We also diversify the dataset with the use of PCMs.

Our major concern is whether FMs (from SPLOT or PCMs) are good ground truths w.r.t ontological semantics. Indeed, a unique characteristic of our work is that we do consider the ontological semantics of the FMs. From this respect, it is hard to certify that the chosen FMs are of good quality. The fact that FMs of SPLOT come from academic publications and practitioners is certainly a good point, but not a guarantee. A possible improvement is a manual review of the FMs, at least to discard FMs with nonsense feature names, at best to possibly improve FMs. The ontological semantics of FMs we extract from PCMs is aligned with the structure of Wikipedia pages and the matrix itself but would also benefit from an external review, *e.g.*, by another pool of researchers.

Another external threat is that we hypothesize that the user effort is reduced thanks to the branching algorithm, the computation of clusters and ranking lists, and the interactive support. We have not run user experiments to validate this claim. Such experiments involve usability of WebFML while we focus on the automated techniques. This evaluation is future work.

7.6.2 Internal Validity

A first *internal threat* is that the manual selection of the SPLOT FMs was done by the authors. To avoid subjective choices, we clearly defined criteria for rejecting an FM before doing the selection. Moreover, the selection was performed separately by two of the authors and their results were cross-checked.

Another internal threat is that the extraction of FMs from PCMs is a mix between automated techniques and manual directives. This creates a threat of potential bias, since the author knew the procedures that were to be evaluated against this model. We take care of retaining the original structure of the PCMs. The manual intervention essentially consists in removing unnecessary columns (like the version number, website or developer name of a product). Importantly, our interpretation of variability remains fixed for all the PCMs (e.g., we interpret a "No" value in a cell as an absence of a feature). Another interpretation of variability can lead to a different set of dependencies and may disturb some heuristics (e.g., the use of the reduced BIG). We plan to further investigate this hypothesis in the future. Moreover, as we apply part of our procedures to Wikipedia PCMs dataset, one might perceive that some of the heuristics, based also on Wikipedia, are biased. However the heuristics do not operate over Wikipedia pages where we extracted the PCM. We exploit Wikipedia as a general ontology.

Another internal threat comes from the manual optimization of the clustering thresholds for the evaluation of the heuristics. Another set of thresholds could generate less favourable results. It is unclear whether this difference would be significant.

The statistical tests performed in the evaluation form another internal threat. Performing a different test or interpreting differently the results could change the conclusions about the effectiveness of our algorithms and heuristics. However, the Wilcoxon test and the 0.05 threshold for the p-values are classical setups for this kind of evaluation. Moreover, we provide all the p-values in Appendix A so that the reader can make his or her own interpretation of the results.

Finally we implement various heuristics and procedures for synthesizing FMs or collecting statistics. Their implementation may be incorrect. We thoroughly tested our infrastructure using test cases and reuse as much as possible existing codes [22, 29, 78]. We replicated numerous times the empirical study, on different datasets (see, e.g., our technical report using an older SPLOT dataset [2]). Besides the collection of results and statistics is fully automated with R scripts.

7.7 Conclusion

In this chapter, we address the problem of synthesising a feature model (FM) conformant to a set of configurations and also exhibiting an appropriate ontological semantics as defined by its hierarchy and feature groups. This problem is crucial for product line (re-)engineering scenarios involving reverse engineering, slicing, or refactoring of FMs.

We develop a series of automated techniques, applicable without prior knowledge or artefacts, to take into account ontological knowledge during FM synthesis. We perform an empirical evaluation on 156 sets of configurations for which we have a ground truth FM. We use two data sets: (1) the SPLOT repository [169] and (2) large FMs extracted from PCMs found in Wikipedia. The FMs come from different domains and their complexity vary. In average, there are 18 features per FM of SPLOT, 72 features per FM of PCMs, and about 7 parent candidates per features to consider. We empirically characterize the strengths and limits of state-of-the-art automated techniques in the quest of breathing ontological knowledge into FM synthesis. The experiments also show that a hybrid approach, mixing ontological and logical techniques, provides the best support for fully synthesizing an FM or for assisting users through ranking lists and clusters.

Our dataset on PCMs from Wikipedia shows that the formalization of a class of PCMs through the use of FMs is possible. As long as the PCM is not ambiguous and that its semantics is encodable in a propositional formula, our techniques can automatically synthesize a corresponding FM.

The data, code, and instructions for reproducing the results are available online <http://tinyurl.com/OntoFMExperiments> and act as a baseline for comparison. Based on our findings, we developed an ontologic-aware synthesis environment, called WebFML, that equips important automated operations for FMs with ontological capabilities. More details can be found in <http://tinyurl.com/WebFMLDemo>.

Specifically, we make the following contributions:

- We develop six heuristics for clustering and ranking the syntactic/semantic relationships between feature names. We also adapt logical heuristics so that they can be applied before "*breathing ontological knowledge*" into FM synthesis;

- We develop WebFML [7], an environment that integrates all the techniques and supports practitioners in synthesizing sound and meaningful FMs from various kinds of artefacts (e.g. propositional formula, dependency graph, FMs or PCMs). We are unaware of such an environment despite the availability of a wide range of academic or industrial feature modeling tools [43, 122, 131, 144, 148, 174, 187];
- The empirical evaluation shows that the hybrid approach can retrieve, in average, 37.8% of parent-child relationships of the SPLOT FMs (44.4% for the PCM dataset) in one step and without any user intervention. Although the hybrid approach constitutes the state-of-the-art heuristic, the results show that a fully automated synthesis is likely to produce FMs far from the ground truths. We provide empirical evidence that the role of the user remains crucial and we highlight the interactive nature of the synthesis process;
- The hybrid approach ranks the correct parent among the 2 first results for 58.9% of the features (for the SPLOT dataset) and 56.3% of the features (for the PCM dataset). The clusters retrieved by the hybrid approach are correct in more than half of the time while the number of clusters to review remains rather low (4.1 for the SPLOT dataset, 17.6 for the PCM dataset);
- We compare our method with an existing technique [101] and logical-based heuristics. Based on empirical results, we analyze the strengths, weaknesses and possible synergies between logical and ontological-based techniques – leading to the design of a hybrid approach.

Chapter 8

Synthesis of Attributed Feature Models from Product Descriptions

"You've been living in a dream world, Neo."

Morpheus

Our procedure in Chapter 7 allow to synthesis an FM from a PCM. The FM formalism that we used has a semantics based on propositional formula. It limits the applicability of our procedure to a class of PCMs encodable in this algebra. However, PCMs contain various kinds of information that are not Boolean (our evaluations in Part II give further details). In this chapter, we extend our techniques to synthesize Attributed Feature Models (AFMs). Thanks to attributes the support of numerical information or enumerations is made possible (see Section 8.1). We formally define the problem of AFM synthesis from a class of PCMs that we call configuration matrix (see Section 8.2). Then, we present the first algorithm for synthesizing AFMs from a class of PCMs (see Section 8.3). Our evaluation focuses on the scalability of the algorithm based on the size and characteristics of the input matrix (see Section 8.4 and 8.5). Then, we discuss threats to the validity of our approach (see Section 8.6). From our evaluation and our different works in Part II, we discuss the transition from PCMs to AFMs (see Section 8.7). Finally, we summarize our contributions in Section 8.8.

8.1 From PCM to AFM

Feature attributes are a useful extension, intensively employed in practice, for documenting the different values across a range of products [39, 43, 60]. With the addition of attributes, optional behaviour can be made dependent not only on the presence or absence of features, but also on the satisfaction of constraints over domain values of attributes [66]. Recently, languages and tools have emerged to fully support attributes in feature modeling and SPL engineering (e.g., see [39, 43, 60, 84, 98]).

Until now, the impressive research effort has focused on synthesizing basic, Boolean feature models – without feature attributes (see Section 3.2, page 26 for further details). Despite the evident opportunity of encoding quantitative information as attributes, the synthesis of attributed feature models has not yet caught attention.

In this section, we motivate the need for an automated encoding of product descriptions as AFMs. We also introduce background related to AFMs.

8.1.1 Product Comparison Matrices and Feature Models

Many modern companies provide solutions for customization and configuration of their products to match the needs of each specific customer. From a user's perspective, it means a large variety of products to choose from. It is therefore crucial for companies not only to provide comprehensive descriptions of their products, but also to do it in an easily navigable manner. Product descriptions

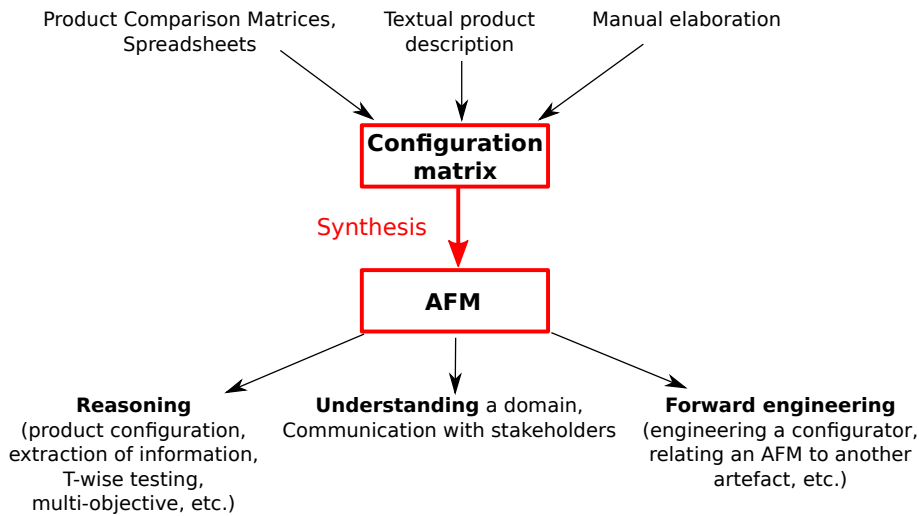

Figure 8.1: Core problem: synthesis of attributed feature model from configuration matrix

Id	License Type	License Price	Language Support	Lang uage	WYSI WYG
W1	Commercial	10	Yes	Java	Yes
W2	NoLimit	20	No	–	Yes
W3	NoLimit	10	No	–	Yes
W4	GPL	0	Yes	Python	Yes
W5	GPL	0	Yes	Perl	Yes
W6	GPL	10	Yes	Perl	Yes
W7	GPL	0	Yes	PHP	No
W8	GPL	10	Yes	PHP	Yes

Figure 8.2: A configuration matrix for Wiki engines.

can be represented in many formats. The objective of such formats is to describe the characteristics of a set of products in order to document and differentiate them.

As we have seen in Chapter 2, PCMs offer one way to achieve this objective. However, the expressiveness of AFMs is not sufficient for representing the entire complexity of PCMs on the Web. In particular, they cannot represent uncertainty or ambiguity that we often encounter in PCMs on the Web. Therefore, we now consider a class of PCMs that we call *configuration matrix* (see Definition 14).

Definition 14 (Configuration matrix). *Let $\mathbf{c}_1, \dots, \mathbf{c}_M$ be a given set of configurations. Each configuration \mathbf{c}_i is an N -tuple $(c_{i,1}, \dots, c_{i,N})$, where each element $c_{i,j}$ is the value of a variable V_j . A variable represents either a feature or an attribute. Using these configurations, we create an $M \times N$ matrix \mathbf{C} such that $\mathbf{C} = [\mathbf{c}_1, \dots, \mathbf{c}_M]^t$, and call it a configuration matrix.*

Figure 8.1 summarizes our motivation for synthesizing an AFM from a configuration matrix. As shown in the upper part of Figure 8.1, the input to the synthesis algorithm is a configuration matrix. Configuration matrices present clear semantics in line with the expressiveness of AFMs. They act as a formal, intermediate representation that can be obtained from various sources, such as (1) PCMs, (2) spreadsheets, (3) disjunction of constraints, or (4) simply through a manual elaboration (e.g., practitioners explicitly enumerate and maintain a list of configurations [45]).

For instance, let us consider the domain of Wiki engines. The list of features supported by a set of Wiki engines can be documented using a configuration matrix. Figure 8.2 is a very simplified configuration matrix, which provides information about eight different Wiki engines.

The resulting AFM (see lower part of Figure 8.1) can as well be used to document a set of configurations and open new perspectives. First, state-of-the-art reasoning techniques for AFM can

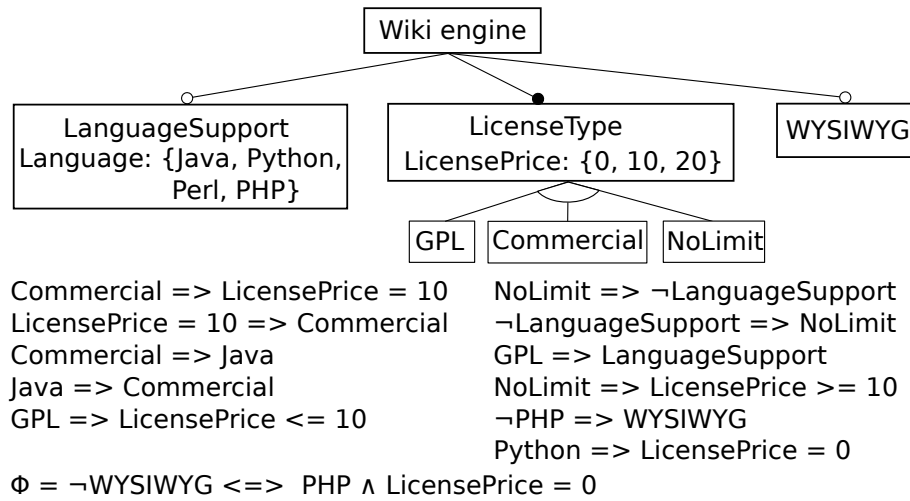

Figure 8.3: One possible attributed feature model for representing the configuration matrix in Figure 8.2

be reused [39,66,98,172]. Second, the hierarchy helps to structure the information and a potentially large number of features into multiple levels of increasing detail [75]. It helps to understand a domain or communicate with other stakeholders [43,45,75]. Finally, an AFM is central to many product line approaches and can serve as a basis for forward engineering [31] (e.g. through a mapping with source code or design models).

Overall, configuration matrices and feature models are semantically related and aim to characterize a set of configurations. The two formalisms are complementary as they propose different views on the same product line. We aim to better understand the gap and switch from one representation to the other. For instance, Figure 8.3 depicts an attributed feature diagram as well as constraints that together provide one *possible* representation of the configuration matrix of Figure 8.2.

8.1.2 Attributed Feature Models

Several formalisms supporting attributes exist [39,44,60,84]. In this chapter, we consider an extension of FODA-like FMs including attributes and inspired from the FAMA framework [43,44]. An AFM is composed of an attributed feature diagram (see Definition 15 and Figure 8.4) and an arbitrary constraint (see Definition 16).

Definition 15 (Attributed Feature Diagram). *An attributed feature diagram (AFD) is a tuple $\langle F, H, E_M, G_{MTX}, G_{XOR}, G_{OR}, A, D, \delta, \alpha, RC \rangle$ such that:*

- F is a finite set of boolean features.
- $H = (F, E)$ is a rooted tree of features where $E \subseteq F \times F$ is a set of directed child-parent edges.
- $E_M \subseteq E$ is a set of edges defining mandatory features.
- $G_{MTX}, G_{XOR}, G_{OR} \subseteq P(E \setminus E_M)$ are sets of feature groups. The feature groups of G_{MTX} , G_{XOR} and G_{OR} are non-overlapping and each feature group is a set of edges that share the same parent.
- A is a finite set of attributes.
- D is a set of possible domains for the attributes in A .
- $\delta \in A \rightarrow D$ is a total function that assigns a domain to an attribute.
- $\alpha \in A \rightarrow F$ is a total function that assigns an attribute to a feature.
- RC is a set of constraints over F and A that are considered as human readable and may appear in the feature diagram in a graphical or textual representation (e.g. binary implication constraints can be represented as an arrow between two features).

RC	$::=$	$bool_factor$	$'\Rightarrow'$	$bool_factor$						
$bool_factor$	$::=$	$feature_name$	$ $	$'\neg'$	$feature_name$	$ $	rel_expr			
rel_expr	$::=$	$attribute_name$	rel_op	$num_literal$						
rel_op	$::=$	$'>'$	$ $	$'<'$	$ $	$'\geq'$	$ $	$'\leq'$	$ $	$'='$

Figure 8.4: The grammar of readable constraints.

A domain $d \in D$ is a tuple $\langle V_d, 0_d, <_d \rangle$ with V_d a finite set of values, $0_d \in V_d$ the null value of the domain and $<_d$ a partial order on V_d . When a feature is not selected, all its attributes bound by α take their null value, i.e. $\forall (a, f) \in \alpha$ with $\delta(a) = \langle V_d, 0_d, <_d \rangle$, we have $\neg f \Rightarrow (a = 0_a)$.

For the set of constraints in RC , formally defining what is human readable is essential for designing automated techniques that can synthesize RC . In this chapter, we define RC as the constraints that are consistent with the grammar¹ in Figure 8.4 (see bottom of Figure 8.3 for examples). We consider that these constraints are small enough and simple enough to be human readable. In this grammar, each constraint is a binary implication, which specifies a relation between the values of two attributes or features. Feature names and relational expressions over attributes are the boolean factors that can appear in an implication. Further, we only allow natural numbers as numerical literals ($num_literal$).

The grammar of Figure 8.4 and the formalism of attributed feature *diagrams* (see Definition 15) are not expressively complete regarding propositional logics, and therefore cannot represent any set of configurations (more details are given in Section 8.2.2). Therefore, to enable accurate representation of any possible configuration matrix, an AFM is composed of an AFD and a propositional formula:

Definition 16 (Attributed Feature Model). *An attributed feature model is a pair $\langle AFD, \Phi \rangle$ where AFD is an attributed feature diagram and Φ is an arbitrary constraint over F and A that represents the constraints that cannot be expressed by RC .*

Example. Figure 8.3 shows an example of an AFM describing a product line of Wiki engines. The feature WikiMatrix is the root of the hierarchy. It is decomposed in 3 features: LicenseType which is mandatory and WYSIWYG and LanguageSupport which are optional. The xor-group composed of GPL, Commercial and NoLimit defines that the wiki engine has exactly 1 license and it must be selected among these 3 features. The attribute LicensePrice is attached to the feature LicenseType. The attribute's domain states that it can take a value in the following set: $\{0, 10, 20\}$. The readable constraints and Φ for this AFM are listed below its hierarchy (see Figure 8.3). The first one restricts the price of the license to 10 when the feature Commercial is selected.

Like FMs, the main objective of an AFM is to define the valid configurations of a product line. A configuration of an AFM is defined as a set of selected features and a value for every attribute. A configuration is valid if it respects the constraints defined by the AFM (e.g. the root feature of an AFM is always selected). The set of valid configurations corresponds to the *configuration semantics* of the AFM (see Definition 17).

Definition 17 (Configuration semantics). *The configuration semantics $\llbracket m \rrbracket$ of an AFM m is the set of valid configurations represented by m .*

8.2 Synthesis Formalization

Two main challenges of synthesizing an AFM from a configuration matrix are (1) preserving the configuration semantics of the input matrix and (2) producing a maximal and readable diagram for a further exploitation by practitioners (see Figure 8.1). Synthesizing an AFM that represents the exact same set of configurations (i.e. configuration semantics) as the input configuration matrix is primordial; a too permissive AFM would expose the user to illegal configurations. To prevent this situation, the algorithm must be sound (see Definition 18). Conversely, if the AFM is too

¹Other kinds of constraints (e.g. based on arithmetic operators) can be considered as well. They may be computationally expensive to synthesize and require the use of constraint-based solvers.

constrained, it would prevent the user from selecting available configurations, resulting in unused variability. Therefore, the algorithm must also be complete (see Definition 19).

Definition 18 (Soundness of AFM Synthesis). *A synthesis algorithm is sound if the resulting AFM (afm) represents only configurations that exist in the input configuration matrix (cm), i.e. $\llbracket afm \rrbracket \subseteq \llbracket cm \rrbracket$.*

Definition 19 (Completeness of AFM Synthesis). *A synthesis algorithm is complete if the resulting AFM (afm) represents at least all the configurations of the input configuration matrix (cm), i.e. $\llbracket cm \rrbracket \subseteq \llbracket afm \rrbracket$.*

To avoid the synthesis of a trivial AFM (e.g. an AFM with the input matrix encoded in the constraint Φ and no hierarchy, i.e. $E = \emptyset$), we target a maximal AFM as output (see Definition 20). Intuitively, we enforce that the feature diagram contains as much information as possible. Definition 21 formulates the AFM synthesis problem addressed in this chapter.

Definition 20 (Maximal Attributed Feature Model). *An AFM is maximal if its hierarchy H connects every feature in F and if none of the following operations are possible without modifying the configuration semantics of the AFM:*

- add an edge to E_M
- add a group to G_{MTX} , G_{XOR} or G_{OR}
- move a group from G_{MTX} or G_{OR} to G_{XOR}
- add a constraint to RC that is not redundant with other constraints of RC or the constraints induced by the hierarchy and feature groups.

Definition 21 (Attributed Feature Model Synthesis Problem). *Given a set of configurations sc , the problem is to synthesize an AFM m such that $\llbracket sc \rrbracket = \llbracket m \rrbracket$ (i.e. the synthesis is sound and complete) and m is maximal.*

8.2.1 Synthesis Parametrization

In Definition 21, we enforce the AFM to be maximal to avoid trivial solutions to the synthesis problem. Despite this restriction, the solution to the problem may not be unique. Given a set of configurations (i.e. a configuration matrix), multiple maximal AFMs can be synthesized.

This property has already been observed for the synthesis of Boolean FMs [165, 166] (see also Chapter 7). Extending boolean FMs with attributes exacerbates the situation. In some cases, the place of the attributes and the constraints over them can be modified without affecting the configuration semantics of the synthesized AFM.

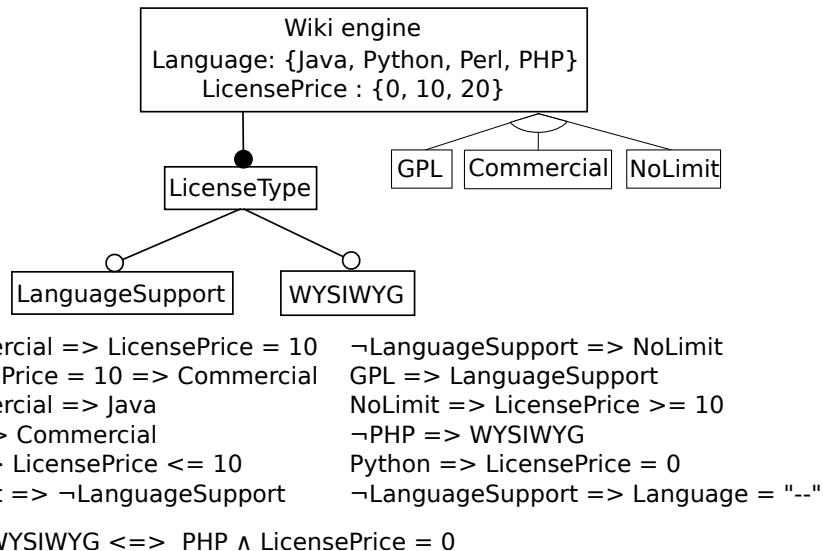

Figure 8.5: Another attributed feature model representing the configuration matrix in Figure 8.2

#	License Type	License Price	Language Support	Language	WYSIWYG
	Feature ▾ Null value	Attribute ▾ Null value	Feature ▾ Null value	Attribute ▾ --	Feature ▾ Null value
0	Commercial	10	Yes	Java	Yes
1	NoLimit	20	No	--	Yes
2	NoLimit	10	No	--	Yes
3	GPL	0	Yes	Python	Yes
4	GPL	0	Yes	Perl	Yes
5	GPL	10	Yes	Perl	Yes
6	GPL	0	Yes	PHP	No
7	GPL	10	Yes	PHP	Yes

Figure 8.6: Web-based tool for gathering domain knowledge during the synthesis

Example. Figures 8.3 and 8.5 depict two AFMs representing the same configuration matrix of Figure 8.2. They have the same configuration semantics but their attributed feature diagrams are different. In Figure 8.3, the feature WYSIWYG is placed under Wiki engine whereas in Figure 8.5, it is placed under the feature LicenseType. Besides the attribute LicensePrice is placed in feature LicenseType in Figure 8.3, whereas it is placed in feature Wiki engine in Figure 8.5.

To synthesize a unique AFM, our algorithm uses *domain knowledge*, which is extra information that can come from heuristics, ontologies or a user of our algorithm. This domain knowledge can be provided interactively during the synthesis or as input before the synthesis. Our synthesis tool (Figure 8.6 shows the workflow) provides an interface for collecting the domain knowledge so that users can:

- decide if a column of the configuration matrix should be represented as a feature or an attribute;
- give the interpretation of the cells (type of the data, partial order);
- select a possible hierarchy, including the placement of each attribute among their legal possible positions;
- select a feature group among the overlapping ones;
- provide specific bounds for each attribute in order to compute meaningful and relevant constraints for RC .

All steps are optional. In case the domain knowledge is missing, the synthesis algorithm (see next section) takes arbitrary yet sound decisions (e.g., random hierarchy).

Example. The domain knowledge that leads to the synthesis of the AFM of Figure 8.3 can be collected with our synthesis tool. Users specify what constitute an attribute or a feature. For instance, the column Language represents an attribute (for which the null value is "--"). In further step, users can specify hierarchy and also precise that, e.g. "10" is an interesting value for LicensePrice when synthesizing constraints.

8.2.2 Over-approximation of the Attributed Feature Diagram

A crucial property of the output AFM is to characterize the exact same configuration semantics as the input configuration matrix (see Definition 21). In fact, the attributed feature *diagram* may over-approximate the configuration semantics, i.e., $\llbracket cm \rrbracket \subseteq \llbracket FD \rrbracket$. Therefore the additional constraint Φ of an AFM (see Definition 16) is required for providing an accurate representation for any arbitrary configuration matrix.

Example. The diagrammatic part of the AFM in Figure 8.3 characterizes two additional configurations that are not in the matrix of Figure 8.2: $\{\text{LicenseType} = \text{GPL}, \text{LicensePrice} = 0, \text{LanguageSupport} = \text{Yes}, \text{Language} = \text{PHP}, \text{WYSIWYG} = \text{Yes}\}$ and $\{\text{LicenseType} = \text{GPL}, \text{LicensePrice} = 10, \text{LanguageSupport} = \text{Yes}, \text{Language} = \text{PHP}, \text{WYSIWYG} = \text{No}\}$. To properly encode the configuration semantics of the configuration matrix, the AFM has to rely on a constraint Φ . This particular constraint cannot be expressed by an attributed feature *diagram* as defined in Definition 15. Therefore, if Φ is not computed the AFM would represent an over-approximation of the configuration matrix.

A basic strategy for computing Φ is to directly encode the configuration matrix as a constraint, i.e., $\llbracket cm \rrbracket = \llbracket \Phi \rrbracket$. Such a constraint can be achieved using the following equation, where N is the number of columns and M is the number of rows.

$$\Phi = \bigvee_{i=1}^M \bigwedge_{j=1}^N (V_j = c_{ij}) \quad (8.1)$$

An advantage of this approach is that the computation is immediate and Φ is, by construction, sound and complete with respect to the configuration semantics. The disadvantage is that some constraints in Φ are likely to be (1) redundant with the attributed feature diagram; (2) difficult to read and understand for a human.

Ideally, Φ should express the exact and sufficient set of constraints not expressed in the attributed feature diagram, i.e., $\llbracket \Phi \rrbracket = \llbracket cm \rrbracket \setminus \llbracket FD \rrbracket$. Synthesizing a minimal set of constraint may require complex and time-consuming computations. The development of efficient techniques for simplifying Φ and investigating the usefulness and readability of arbitrary constraints² are out of the scope of this thesis.

8.3 Synthesis Algorithm

Algorithm 1 presents a high-level description of our approach for synthesizing an Attributed Feature Diagram (AFD). The two inputs of the algorithm are a configuration matrix and some domain knowledge for parametrizing the synthesis. The output is a maximal AFD. In complement to the AFD, we compute the constraint Φ (as described by Equation 8.1). The addition of Φ and the AFD forms the AFM.

8.3.1 Extracting Features and Attributes

The first step of the synthesis algorithm is to extract the features (F), the attributes (A) and their domains (D, δ). This step essentially relies on the domain knowledge to decide how each column of the matrix must be represented as a feature or an attribute. We also discard all the dead features, i.e. features that are always absent. The domain knowledge specifies which values in the corresponding column indicate the presence (e.g. by default "Yes") or absence (e.g. "No") of the feature. For each attribute, all the distinct values of its corresponding column form the first part of its domain (V_d). The other parts, the null value 0_d , and the partial order $<_d$, are computed accordingly. Some pre-defined heuristics are implemented to populate the domain knowledge and consist in (1) determining whether a column is a feature or an attribute or (2) typing the domain values. If needs be, users can override the default behaviour of the synthesis and specify domain knowledge.

²We recall that *relational* constraints as defined by the grammar of Figure 8.4 are already part of the synthesis. Arbitrary constraints represent other forms of constraints involving more than two features or attributes – hence questioning their usefulness or readability by humans.

Algorithm 1 ATTRIBUTED FEATURE DIAGRAM SYNTHESIS**Require:** A configuration matrix **MTX** and domain knowledge **DK****Ensure:** An attributed feature diagram **AFD**

```

Extract the features, the attributes and their domains
1  $(F, A, D, \delta) \leftarrow \text{extractFeaturesAndAttributes}(MTX, DK)$ 

Compute binary implications
2  $BI \leftarrow \text{computeBinaryImplications}(MTX)$ 

Define the hierarchy
3  $(BIG, MTXG) \leftarrow \text{computeBIGAndMutexGraph}(F, BI)$ 
4  $H \leftarrow \text{extractHierarchy}(BIG, DK)$ 
5  $\alpha \leftarrow \text{placeAttributes}(BI, F, A, DK)$ 

Compute the variability information
6  $E_M \leftarrow \text{computeMandatoryFeatures}(H, BIG)$ 
7  $FG \leftarrow \text{computeFeatureGroups}(H, BIG, MTXG, DK)$ 

Compute cross tree constraints
8  $RC \leftarrow \text{computeConstraints}(BI, DK, H, E_M, FG)$ 

Create the attributed feature diagram
9 return  $AFD(F, H, E_M, FG, A, D, \delta, \alpha, RC)$ 

```

Example. Let us consider the variable `LanguageSupport` in the configuration matrix of Figure 8.2. Its domain has only 2 possible Boolean values: *Yes* and *No*. Therefore, the variable `LanguageSupport` is identified as a feature. Following the same process, `WYSIWYG` and `LicenseType` are also identified as features while the other variables are identified as attributes. For instance, `LicensePrice` is an attribute and its domain is the set of all values that appear in its column: $\{0, 10, 20\}$.

8.3.2 Extracting Binary Implications

An important step of the synthesis is to extract binary implications between features and attributes. A binary implication, for a given configuration matrix **C**, is of the form $(v_i = u) \Rightarrow (v_j \in S_{i,j,u})$, where i and j indicate two distinct columns of **C**, and $S_{i,j,u}$ is the set of all values in the j th column of **C**, for which the corresponding cell in the i th column is equal to u . We denote the set of all binary implications of **C** as $BI(\mathbf{C})$. Algorithm 2 computes this set. The algorithm iterates over all pairs (i, j) of columns and all configurations c_k in C to compute $S(i, j, c_{k,i})$ (i.e., $S_{i,j,c_{k,i}}$).

Algorithm 2 COMPUTEBINARYIMPLICATIONS**Require:** A configuration matrix **C****Ensure:** A set of binary implications **BI**

```

1  $BI \leftarrow \emptyset$ 
2 for all  $(i, j)$  such that  $1 \leq i, j \leq N$  and  $i \neq j$  do
3   for all  $c_k$  such that  $1 \leq k \leq M$  do
4     if  $S(i, j, c_{k,i})$  does not exist then
5        $S(i, j, c_{k,i}) \leftarrow \{c_{k,j}\}$ 
6        $BI \leftarrow BI \cup \{(i, j, u, S(i, j, c_{k,i}))\}$ 
7     else
8        $S(i, j, c_{k,i}) \leftarrow S(i, j, c_{k,i}) \cup \{c_{k,j}\}$ 
9 return  $BI$ 

```

In line 4, the algorithm tests if $S(i, j, c_{k,i})$ already exists. If so, the algorithm simply adds $c_{k,j}$, the value of column j for configuration c_k , to the set $S(i, j, c_{k,i})$. Otherwise, $S(i, j, c_{k,i})$ is initialized with a set containing $c_{k,j}$. Then, a new binary implication is created and added to the set BI . At the end of the inner loop, BI contains all the binary implications of all pairs of columns (i, j) .

8.3.3 Defining the Hierarchy

The hierarchy H of an AFD is a rooted tree of features such that $\forall(f_1, f_2) \in E, f_1 \Rightarrow f_2$, *i.e.* each feature implies its parent. As a result, the candidate hierarchies, whose parent-child relationships violate this property, can be eliminated upfront. To guide the selection of a legal hierarchy for the AFD, we rely on the *Binary Implication Graph* (BIG) of a configuration matrix:

Definition 22 (Binary Implication Graph (BIG)). *A binary implication graph of a configuration matrix \mathbf{C} is a directed graph (V_{BIG}, E_{BIG}) where $V_{BIG} = F$ and $E_{BIG} = \{(f_i, f_j) \mid (f_i \Rightarrow f_j) \in BI(\mathbf{C})\}$.*

The BIG aims to represent all the binary implications, thus representing every possible parent-child relationships in a legal hierarchy. We compute the BIG as follows: for each constraint in BI (see Algorithm 2) involving two features we add an edge in the BIG. Hierarchy H of the AFD is a rooted tree inside the BIG. In general, it is possible to find many such trees. As part of the tool (see Figure 8.6), users can specify domain knowledge to select a tree. The *BIG* is exploited to interactively assist users in the selection of the AFD's hierarchy. In case the domain knowledge is incomplete, a branching of the graph (the counterpart of a spanning tree for undirected graphs) is randomly computed [3].

After choosing the hierarchy of features, we focus on the placement of attributes. An attribute a can be placed in a feature f if $\neg f \Rightarrow (a = 0_a)$. As a result, the candidate features verifying this property are considered as legal positions for the attribute. We promote, according to the domain knowledge, one of the legal positions of each attribute.

Example. In Figure 8.2, the attribute `Language` has a domain d with “-” as its null value, *i.e.* $0_d = \text{“-”}$. This null value restricts the place of the attribute. The property $\neg f \Rightarrow (a = 0_a)$ of Definition 15 holds for the attribute `Language` and the feature `LanguageSupport`. However, the configuration `W7` forbids the attribute to be placed in feature `WYSIWYG`. The value of `Language` is not equal to its null value when `WYSIWYG` is not selected.

8.3.4 Computing the Variability Information

As the hierarchy of an AFD is made of features only, attributes do not impact the computation of the variability information (optional/mandatory features and feature groups). Therefore, we can rely on algorithms that have been developed for Boolean FMs [3, 165, 166] such as the one in Chapter 7.

First, for the computation of mandatory features, we rely on the *BIG* as it represents every possible implication between two features. For each edge (c, p) in the hierarchy, we check that the inverted edge (p, c) exists in the *BIG*. In that case, we add this edge to E_M .

For feature groups, we reuse algorithms from the synthesis of Boolean FMs [3, 165, 166]. For the sake of self-containedness, we briefly describe the computation of each type of group.

For mutex-groups (G_{MTX}), we compute a so-called *mutex graph* that contains an edge whenever two features are mutually exclusive. The maximum cliques of this mutex graph are the mutex-groups [165, 166].

For or-groups (G_{OR}), we translate the input matrix to a binary integer programming problem [166]. Finding all solutions to this problem results in the list of or-groups.

For xor-groups (G_{XOR}), we consider mutex-groups since a xor-group is a mutex-group with an additional constraint stating that at least one feature of the group should be selected. We check, for each mutex-group, that its parent implies the disjunction of the features of the group. For that, we iterate over the binary implications (BI) until we find that the property is inconsistent. To ensure the maximality of the resulting AFM, we discard any or-group or mutex-group that is also an xor-group.

Finally, the features that are not involved in a mandatory relation or a feature group are considered optional.

8.3.5 Computing Cross Tree Constraints

The final step of the AFD synthesis algorithm is to compute cross tree constraints (RC). We generate three kinds of constraints: *requires*, *excludes* and *relational* constraints.

A requires constraint represents an implication between two features. All the implications contained in the BIG (*i.e.* edges) that are not represented in the hierarchy or mandatory features, are promoted as requires constraints (*e.g.* the implication `Commercial` \Rightarrow `Java` in Figure 8.3).

Excludes constraints represent the mutual exclusion of two features. Such constraints are contained in the mutex graph. As the previously computed mutex-groups may not represent all the edges of the mutex graph, we promote the remaining edges of the mutex graph as excludes constraints. For example, the features `NoLimit` and `LanguageSupport`, in Figure 8.3, are mutually exclusive. This relation is included in *RC* as an excludes constraint: `NoLimit` \Rightarrow \neg `LanguageSupport`.

Finally, relational constraints are all the constraints following the grammar described in Figure 8.4 and involving at least one attribute. Admittedly there is a huge number of possible constraints that respect the grammar of *RC*. Our algorithm relies on some domain knowledge (see Figure 8.6) to restrict the domain values of attributes considered for the computation of *RC*. Formally, the knowledge provides the information required for merging binary implications as (a_i, k) pairs, where a_i is an attribute, and k belongs to D_i . In case the knowledge is incomplete (*e.g.*, users do not specify a bound for an attribute), we randomly choose a value among the domain of an attribute.

Then the algorithm proceeds as follows. First, we transform each constraint referring to one feature and one attribute to a constraint that respects the grammar of *RC*. Then, we focus on constraints in *BI* that involve two attributes and we merge them according to the domain knowledge. Using the pairs (a_i, k) of the domain knowledge, we partition the set of all binary implications with $a_i = u$ on the left hand side of the implication into three categories: those with $u < k$, those with $u = k$, and those with $u > k$. Let $b_{j,1}, \dots, b_{j,p}$ be all such binary implications, belonging to the same category, and involving a_j (*i.e.*, each $b_{j,r}$ is of the form $(a_i = u_r \Rightarrow a_j \in S_r)$). We merge these binary implications into a single one: $(a_i \in \{u_1, \dots, u_p\} \Rightarrow a_j \in S_1 \cup \dots \cup S_p)$ whenever the conformance of the grammar of *RC* holds.

Example. From the configuration matrix of Figure 8.2, we can extract the following binary implication: `GPL` \Rightarrow `LicensePrice` \in $\{0, 10\}$. We also note that the domain of `LicensePrice` is $\{0, 10, 20\}$. Therefore, the right side of the binary implication can be rewritten as `LicensePrice` \leq 10. As this constraint can be expressed by the grammar of *RC*, we add `GPL` \Rightarrow `LicensePrice` \leq 10 to *RC* (see Figure 8.3).

8.4 Evaluation on Random Matrices

We developed a tool³ that implements Algorithm 1. The tool is mainly implemented in Scala programming language. Algorithm 2 is written in pure Scala and relies on appropriate data structures (*e.g.* `HashMap` and `HashSet`) for efficient computation of implications. For the computation of or-groups, we rely on the SAT4J solver⁴.

To provide an insight into the scalability of our procedure, we experimentally evaluate the runtime complexity of our AFD synthesis procedure. For this purpose, we have developed a random matrix generator, which takes as input three parameters:

- number of variables (features and attributes)
- number of configurations
- maximum domain size (*i.e.* maximum number of distinct values in a column)

The type of each variable (feature or attribute) is randomly selected according to a uniform distribution. An important property is that our generator does not ensure that the number of configurations and the maximum domain size are reached at the end of the generation. Any duplicated configuration or missing value of a domain is not corrected. Therefore, the parameters entered for our experiments may not reflect the real properties of the generated matrices. To avoid any misinterpretation or bias, we present the concrete numbers in the following results.

³The complete source code can be found in <https://github.com/gbecan/FOReverSE-AFMSynthesis>

⁴<http://www.sat4j.org>

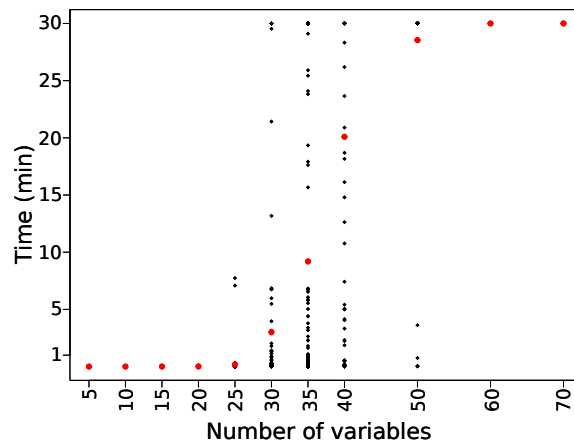

Figure 8.7: Scalability of or-groups computation w.r.t the number of variables

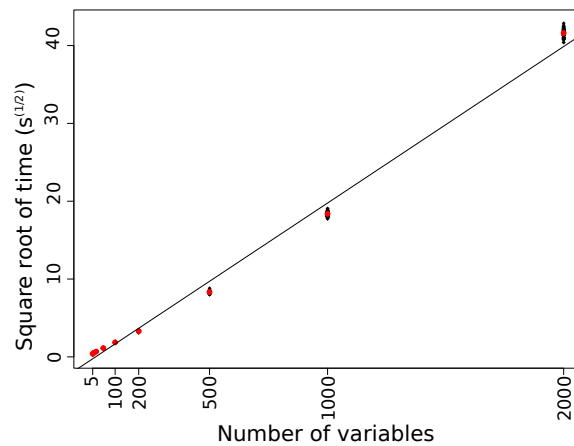

Figure 8.8: Scalability w.r.t the number of variables

Moreover, to reduce fluctuations caused by the random generator, we perform the experiments at least 100 times for each triplet of parameters. In order to get the results in a reasonable time, we used a cluster of computers. Each node in the cluster is composed of two Intel Xeon X5570 at 2.93 Ghz with 24GB of RAM.

8.4.1 Initial Experiments with Or-groups

We first perform some initial experiments on random matrices. We quickly notice that computation of the or-groups posed a scalability problem. It is not surprising since this part of the synthesis algorithm is NP-hard, leading to some timeouts even for Boolean FMs (e.g., see [166]).

Specifically, we measured the time needed to compute the or-groups from a matrix with 1000 configurations, a maximum domain size of 10 and a number of variables ranging from 5 to 70. To keep a reasonable time for the execution of the experiment, we set a timeout at 30 minutes. Results are presented in Figure 8.7. The red dots indicate average values in each case. The results confirm that the computation of or-groups quickly becomes time consuming. The 30 minutes timeout is reached with matrices containing only 30 variables. With at least 60 variables, the timeout is systematically reached. Therefore, we deactivated the computation of or-groups in the following experiments.

8.4.2 Scalability with respect to the number of variables

To evaluate the scalability with respect to the number of variables, we perform the synthesis of random matrices with 1000 configurations, a maximum domain size of 10 and a number of variables

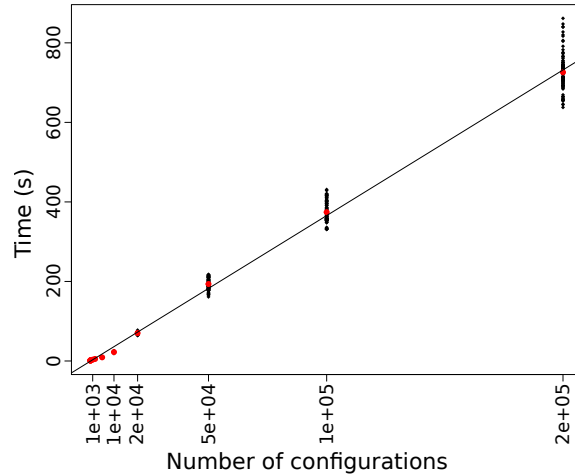

Figure 8.9: Scalability w.r.t the number of configurations

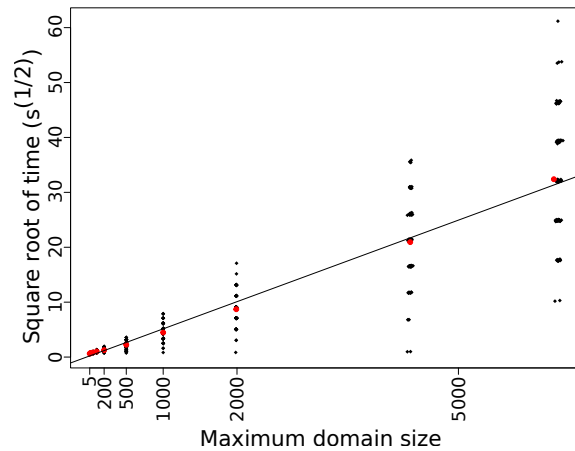

Figure 8.10: Scalability w.r.t the maximum domain size

ranging from 5 to 2000. In Figure 8.8, we present the square root of the time needed for the whole synthesis compared to the number of variables. As shown by the linear regression line, the square root of the time grows linearly with the number of variables, with a correlation coefficient of 0.997.

8.4.3 Scalability with respect to the number of configurations

To evaluate the scalability with respect to the number of configurations, we perform the synthesis of random matrices with 100 variables, a maximum domain size of 10 and a number of configurations ranging from 5 to 200,000. With 100 variables, and 10 as the maximum domain size, we can generate 10^{100} distinct configurations. This number is big enough to ensure that our generator can randomly generate 5 to 200,000 distinct configurations.

Figure 8.9 reports the synthesis time in each case. As shown in this figure, the time grows linearly with the number of configurations, and the correlation coefficient is 0.997.

8.4.4 Scalability with respect to the maximum domain size

To evaluate the scalability with respect to the maximum domain size, we perform the synthesis of random matrices with 10 variables, 10,000 configurations and a maximum domain size ranging from 5 to 10,000⁵.

⁵Our random matrix generator cannot ensure that the maximum domain sizes are always reached. It explains why we report in Figure 8.10 the measures for a maximum domain size of 4,385 (resp. 6,416) instead of 5000 (resp.

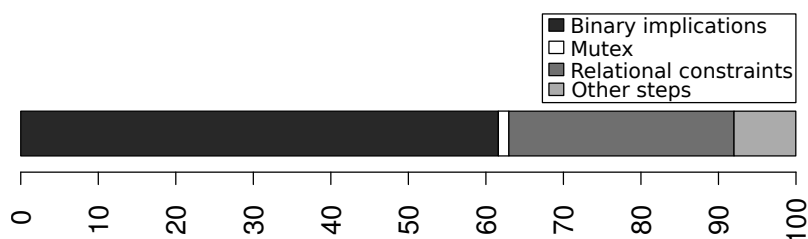

Figure 8.11: Time complexity distribution for all experiments without or-groups computation

Figure 8.10 presents the square root of the synthesis time. We notice that for each value of the domain size, the points are distributed in small groups. For instance, we can see nine groups of points for a maximum domain size of 2000. Each group represents the execution of our algorithm with matrices that have the same number of attributes. However, we see that the number of attributes does not significantly affect the maximum domain size (the maximum domain size is approximately the same for all groups of results).

A linear regression line fits the average square root of the time, with a correlation coefficient of 0.932. This implies that the synthesis time grows quadratically with the maximum domain size.

8.4.5 Time Complexity Distribution

To further understand the overall time complexity, we analyze its distribution over different steps of the algorithm (see Figure 8.11). The results clearly show that the major part of the algorithm is spent on the computation of binary implications and relational constraints for *RC*. The rest of the synthesis represents less than 10% of the total duration.

According to our *theoretical* analysis (see [5] for details), the two hard parts of the synthesis algorithm are the computation of mutex-groups (exponential complexity) and or-groups (NP-complete). We note that 93.8% of the configuration matrices in our dataset produce mutex graphs that contain absolutely no edges. In such cases, computing mutex-groups is trivial. The rest of the algorithm has a polynomial complexity, which is confirmed by the experiments presented in this section.

8.5 Evaluation on Real Matrices

To provide an insight into the scalability of our approach on realistic configuration matrices, we executed our algorithm on configuration matrices extracted from *Best Buy* website. *Best Buy* is a well known American company that sells consumer electronics. On their website, the description of each product is completed with a matrix that describes technical information. Each matrix is formed of two columns in order to associate a feature or an attribute of a product to its value. The website offers a way to compare products that consists in merging the matrices to form a single configuration matrix which is similar to the one in Figure 8.2.

8.5.1 Experimental Settings

We developed an automated technique to extract configuration matrices from *Best Buy* website. The procedure is composed of 3 steps. First, it selects a set of products whose matrices have at least 75% of feature and attributes in common. Then, it merges the corresponding matrices of the selected product to obtain a configuration matrix. Unfortunately, the resulting configuration matrix may contain empty cells. Such cells have no clear semantics from a variability point of view. The last step of the procedure consists in giving an interpretation to these cells. If a feature or an attribute contain only integers, the empty cells are interpreted as "0". Otherwise, the empty cells are interpreted as "No" which means that the feature or attribute is absent.

Table 8.1: Statistics on the *Best Buy* dataset.

	Min	Median	Mean	Max
Variables	23	50.0	48.6	91
Configurations	11	27.0	47.1	203
Max domain size	11	27.0	47.1	203
Empty cells before interpretation	2.5%	16.1%	14.4%	25.0%

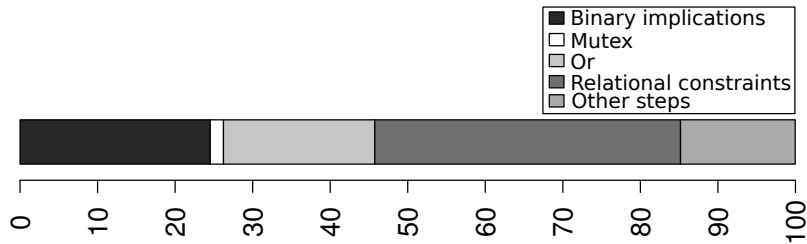
Figure 8.12: Time complexity distribution of Algorithm 1 on the *Best Buy* dataset

With this procedure, we extracted 242 configuration matrices from the website that form our dataset for the experiment. Table 8.1 reports statistics on the dataset about the number of variables, configurations, the maximum domain size and the number of empty cells before interpretation.

In the following experiments, we measure the execution time of Algorithm 1 on the *Best Buy* dataset. We execute the algorithm on the same cluster of computers in order to have comparable results with previous experiments on random matrices. We also execute the synthesis 100 times for each configuration matrix of the dataset in order to reduce fluctuations caused by other programs running on the cluster and the random decisions taken during the synthesis.

8.5.2 Scalability

We first measure the execution time of Algorithm 1 with the computation of or-groups activated. On the *Best Buy* dataset, the execution time of Algorithm 1 is 0.8s in average with a median of 0.5s. The most challenging configuration matrix has 73 variables, 203 configurations and a maximum domain size of 203. The synthesis of an AFM from this matrix takes at most 274.7s. Figure 8.12 reports the average distribution for the dataset. It shows that the computation of binary implications, or-groups and the relational constraints are the most time-consuming tasks. It confirms the results of the experiments on random matrices. However, we note that on the *Best Buy* dataset, the computation of or-groups can be executed in a reasonable time.

To further compare with previous experiments, we performed the same experiment but with the computation of or-groups deactivated. In these conditions, the execution time of Algorithm 1 is 0.5s in average with a median of 0.4s. This time, the most challenging configuration matrix has 77 variables, 185 configurations and a maximum domain size of 185. The synthesis of its corresponding AFM takes only 2.1s. The experiments confirm that the computation of or-groups is the hardest part of the algorithm. It also shows that the synthesis algorithm ends in reasonable time for all the configuration matrices of the *Best Buy* dataset.

Moreover, the execution time on a random matrix with 100 variables, 200 configurations and a maximum domain size of 10 is at most 2.3s. It indicates that the execution time on the most challenging matrix of the *Best Buy* dataset has the same order of magnitude as the execution time on a similar random matrix.

8.6 Threats to Validity

An external threat is that the evaluation of Section 8.4 is based on the generation of random matrices. Using such matrices may not reflect the practical complexity of our algorithm. To

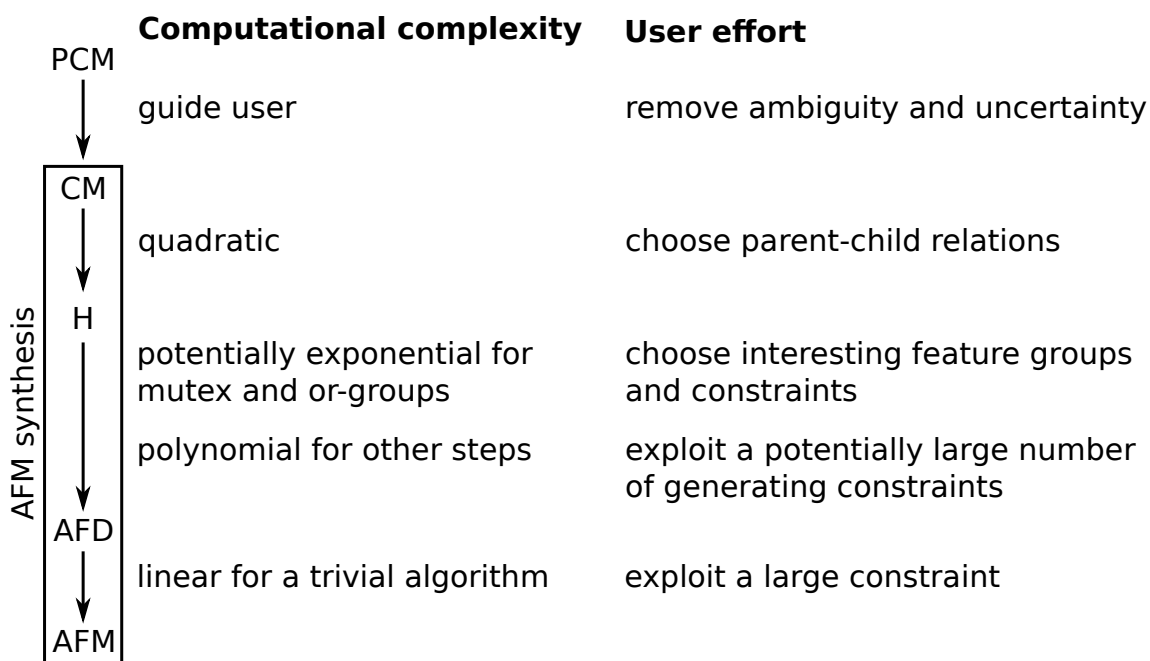

Figure 8.13: Main steps for going from a PCM to an AFM

mitigate this threat we complement the evaluation with a realistic data set (*Best Buy*).

Evaluating the scalability on a cluster of computers instead of a single one may impact the scalability results and is an internal threat to validity. We use a cluster composed of identical nodes to limit this threat. Even if the nodes do not represent standard computers, the practical complexity of the algorithm is not influenced by this gain of processing power. Moreover, all the necessary data for the experiments are present in the local disks of the nodes thus avoiding any network related issue. Finally, we performed 100 runs for each set of parameters in order to reduce any variation of performance. Another threat to internal validity is related to our interpretation of cell values in realistic matrices of Section 8.5. Another semantics for empty cells may have an influence on the results. Our initial experiments (not reported in this thesis) did not reveal significant changes.

To check the correctness of the implementation, we have manually reviewed some resulting AFMs. We also tested the algorithm against a set of manually designed configuration matrices. Each matrix represents a minimal example of a construct of an AFM (*e.g.* one of the matrices represents an AFM composed of a single xor-group). The test suite covers all the concepts in an AFM. None of these experiments revealed any anomalies in our implementation.

8.7 Discussion

The transition from a PCM to an AFM is a complex task that can be decomposed in 4 main steps. Each step is a transition from one formalism to the other.

The first step is to go from a PCM to a configuration matrix. PCMs may contain ambiguity, uncertainty or types of data that we cannot model with AFMs. Before applying our AFM synthesis techniques, we must refine or remove all this information. By transitioning from PCM to configuration matrix, we gain clear semantics. OpenCompare and the different services that we presented in Part II can help in performing this task. However, it typically requires important effort from the user.

The second step is to extract a hierarchy of features from the configuration matrix. It allows to switch from a product-based view to a feature-based view. This allows to have a very broad representation of the product line and its organization. For example, it can be used to guide the generation of a configurator. In this context, the hierarchy gives the organization of the questions

inferred from the features. As we showed in Chapter 7, a fully automated synthesis is unlikely. The heuristics that we developed can help in choosing parent-child relations. However, user knowledge is often required to obtain a high quality hierarchy.

The third step is to add variability information to the hierarchy of the AFM in order to obtain an attributed feature diagram. Basically, we add mandatory or optional features, feature groups and basic cross-tree constraints to the hierarchy. The resulting feature diagram still represents an overapproximation of the product line but it represents a more precise overview than the hierarchy alone. Let continue with our example of the generation of a configurator. Having an attributed feature diagram allows to infer how to represent the possible answers of each question. For instance, we can generate radio buttons for a xor-group and check boxes for an or-group. It also allows to propagate some constraints (*e.g.* a require constraint) while the user perform its selection. These operations are not possible with the hierarchy alone.

As we have seen with or-groups, computing all these information can be costly. In addition, the number of generated constraints can be important. As part of our experiments, we report that the number of constraints synthesized for the random dataset is 237 in average with a maximum of 8906. The *Best Buy* dataset exhibits 6281 constraints in average with a maximum of 28300. We can assume there are more constraints since the number of configurations is lower. Again some user effort can be required to select the feature groups and constraints that are relevant for the intended application of the model.

The fourth and final step is to add an additional formula Φ to the attributed feature diagram. The formula can be directly extracted from the configuration matrix with Equation 8.1. This leads to a formula that has the size of the input matrix and contain redundant information with respect to the feature diagram. The formula is unlikely to be exploitable by a human. Yet, it brings soundness to the synthesis procedure. This is particularly useful for reasoning on the product line. If we push further our example of the configurator, having an AFM ensures that the user can explore the entire product space. His or her selection will lead to an existing product of the product line modeled by the AFM. To make the constraint readable or at least reduce its size, numerous strategies can be considered. For example, we can use minimisation [181], prioritization, or let users control the constraint they want.

Overall, we notice that each step requires potentially high computational or user effort (see Figure 8.13 for a summary). In extreme cases, the cost of synthesizing an AFM or exploiting it becomes greater than the cost of directly using a PCM or a configuration matrix. Therefore, the transition to another formalism must be strongly motivated by the objective of the user. If for your application a hierarchy of features is enough, then it is not necessary to risk a combinatorial explosion by synthesizing a complete AFM. In another example, if your product line is highly constrained, it may be easier to use exploit a configuration matrix instead of an attributed feature diagram with numerous constraints. It is important to evaluate the benefits of a formalism compared to the price of its synthesis and its exploitation.

8.8 Conclusion

Developing techniques for synthesizing attributed feature models requires to cope with extra complexity. A synthesis algorithm must decide what becomes a feature, what becomes an attribute and identify the domain of each attribute. Compared to features, the domain of an attribute may contain more than two values. Moreover, the placement of the attributes further increases the number of possible hierarchies in a feature model. Finally, cross-tree constraints over attributes are now possible; this level of expressiveness (beyond Boolean logic) challenges synthesis techniques.

In this chapter, we developed the theoretical foundations and algorithms for synthesizing attributed feature models given a configuration matrix. Configuration matrices document a set of products along different Boolean and numerical values. They form a class of PCMs that are covered by the semantics of AFMs. We presented parametrizable, tool-supported techniques for computing hierarchies, feature groups, placements of feature attributes, domain values, and constraints. We described algorithms for comprehensively computing logical relations between features and attributes. Our synthesis algorithm is capable of taking knowledge (*e.g.*, about the hierarchy and placement of attributes) into account so that users can specify, if needs be, a hierarchy or some

placements of attributes. Our work both strengthens the understanding of the formalism and provides a tool-supported solution.

Furthermore, we evaluated the practical scalability of our synthesis procedure with regards to the number of configurations, features, attributes, and domain values by using randomized configuration matrices and real-world examples. Our results show that our approach can synthesize matrices containing up to 2,000 attributed features, and 20,000 distinct configurations in less than a couple of minutes.

Finally, we detailed the different steps to synthesize an AFM from a PCM. We highlighted the syntactic and semantic gap between PCMs and AFMs and its impact on the computational and user effort of the synthesis. We also show that the use of intermediate representation (*e.g.* the hierarchy of the AFM or the attributed feature diagram) can be sufficient for some applications while requiring less effort to synthesize. We conclude that the synthesis of AFMs from PCMs must be strongly motivated by the benefits of exploiting such formalism for a given application.

The key contributions of the chapter can be summarized as follows:

- We described formal properties of AFMs (over-approximation, equivalence) and established semantic correspondences with the formalism of configuration matrices (Section 8.2);
- We designed and implemented a tool-supported, parameterizable synthesis algorithm (Section 8.3);
- We empirically evaluated the scalability of the synthesis algorithm on random (Section 8.4) and real-world matrices (Section 8.5).
- We highlighted the syntactic and semantic gap between PCMs and AFMs. We also showed the potential computational and user effort required to synthesize an AFM from a PCM.

Part IV

Conclusion and Perspectives

Chapter 9

Conclusion

"Everything that has a beginning has an end."

The Oracle

The Web forms a large and growing source of unstructured data [55]. This data comes in various formats and is created by numerous contributors. The amount of data and its diversity challenges the development of software that can process this information. Product Comparison Matrices (PCMs) are an example of this phenomenon. They are simple and convenient ways to document a product line. This simplicity hides a large diversity of information, formats and practices. The lack of a standard format or guidelines worsens the situation. PCMs may also contain ambiguous or uncertain information. Overall, it makes the creation and exploitation of PCMs difficult, whether it is realized by humans or machines. To overcome the situation, there is a need for a precise model or formalism for PCMs. Therefore, in this thesis we address the following question: *how to formalize product comparison matrices?*

In this context, we explored two approaches that aim at defining a formalism for PCMs and automatically transform raw PCMs into this formalism. The first one is a model-based approach that is composed of a metamodel and a transformation from raw PCMs to PCM models conformant to the metamodel. The second one is the synthesis of Feature Models (FMs) from PCMs. To evaluate our approaches we often relied on the case study of Wikipedia. With more than 5 millions articles, the encyclopedia contains numerous and diverse PCMs that are challenging for our techniques. We now discuss how our approaches contribute to the formalization of PCMs.

9.1 Formalizing PCMs Via Metamodeling

As we noted in Chapter 2, PCMs can be considered as a special case of tables or spreadsheets. Despite the significant amount of work for the formalization and automated processing of these two kinds of artifacts, no formalism for PCMs has been proposed. Our first contribution is thus to propose a model-based approach for the formalization of PCMs (see Part II). This approach is mainly composed of a metamodel describing the domain of PCMs and a transformation from raw PCMs to PCM models conformant to the metamodel.

Designing a model-based approach for PCMs is a challenging task. There is no identified expert, standard or oracle that can help us to elaborate the metamodel and the transformation. In addition, the tremendous number of PCMs on the Web hinders a comprehensive exploration of existing PCMs or the manual construction of an oracle. This challenges the selection of a small and representative dataset of PCMs on which we can base the design of our metamodel. Moreover, we cannot rely on an oracle to test our transformation on numerous PCMs. Finally, it challenges the elaboration of a metamodel that can support the development of services dedicated to PCMs.

To address these challenges, we proposed an iterative process. It relies on the automated transformation of a large dataset of PCMs into PCM models. The metamodel and the generated models are evaluated according to three kinds of experiments. First, we perform automated analyses based

on statistics and metamorphic tests to respectively measure the use of the concepts in our metamodel and assess the precision of our transformation. Second, we ask users to check the precision and relevance of our formalization on a small set of PCMs. Finally, we implement numerous services on top of our metamodel. The feedback from the developers provides insights on the usability and learnability of our metamodel. Based on this evaluation, we refine our metamodel and transformation. We iterate by applying the new transformation on the dataset of PCMs in order to obtain new PCM models. Our iterative process is thus driven by data, end-users and services.

Following our process, we designed a model-based approach for the formalization of PCMs. The central element of this approach is a domain metamodel which describes the structure and semantics of a PCM. The structure is mainly composed of products and features which reflects the underlying domain of product lines. By doing so, we abstract away the implementation and graphical details (*e.g.* rows and columns) of common formats for describing PCMs such as HTML, CSV or wikitext. For the semantics, the metamodel provides built-in variability patterns that we can observe in cells of PCMs. For instance, it contains concepts of Boolean, numerical, multiple and conditional information. It can also model information that is not available or partially provided.

On top of this metamodel, we defined a set of generic and automated transformations for going from a raw PCM to a PCM model conformant to the domain metamodel. As part of this transformation chain, we developed a set of rules that interpret the content of cells and encode them in the variability patterns of the domain metamodel. Based on this information, we developed generic algorithms for detecting the orientation of a PCM and extract its logical structure (features and products). A first evaluation on 75 PCMs from Wikipedia shows that we are able to retrieve the semantics of a cell in 93.11% of the cases. We performed a second evaluation on the comprehensive dataset of the English version of Wikipedia. The results indicate that our import and export capabilities are able to automatically process 91% of the 1,501,406 PCMs that we extracted from the dataset.

We completed the domain metamodel with a set of specialized metamodels for the manipulation, edition and import/export of PCM models. The rationale is to separate each concern of the lifecycle of a PCM into a dedicated metamodel. With the cooperation of researchers, engineers and students, we implemented several services for PCMs. For instance, we provide an editor, a comparator, a configurator and statistical visualizations. We also support CSV, HTML and wikitext files in our importing and exporting procedures. The feedback we gathered during these numerous developments were encouraging regarding the relevance and quality of our approach. In particular, we improve the comprehension and usability of our first attempt described in Chapter 5.

The majority of the metamodels and services that we developed during this thesis are integrated into an initiative called OpenCompare. The facade of this project is the website opencompare.org. With this initiative we aim to create a community of PCM contributors and users, and support their activity by providing innovative services for PCMs.

With our iterative process, we were able to design a metamodel that is relevant to the domain of PCMs. It provides the necessary concepts for defining the logical structure and semantics of PCMs. Moreover, our generic transformations can accurately transform a large diversity of PCMs into PCM models. Finally, a set of task-specific metamodels support and ease the development of various services dedicated to PCMs. Overall, our model-based approach provides a generic and precise formalization of PCMs.

9.2 Formalizing PCMs Via the Synthesis of Feature Models

A PCM is a simple way to describe a product line. Several formalisms have been proposed to model a product line. The defacto standard is called feature modeling. However, the manual elaboration of an FM can be time-consuming and error-prone. Numerous techniques have been proposed to synthesize FMs from various kinds of artifacts. Our analysis of the state of the art of Chapter 3 reveals two main limitations in existing synthesis techniques. The first one is the lack of techniques that respect both configuration and ontological semantics of the input product line. This hinders the exploitation of FMs. The second limitation is that all the synthesis techniques targets Boolean FMs. This ignores the different extensions to feature modeling. In particular, we are interested in Attributed FMs (AFMs) which can model more than Boolean information. This reflects the

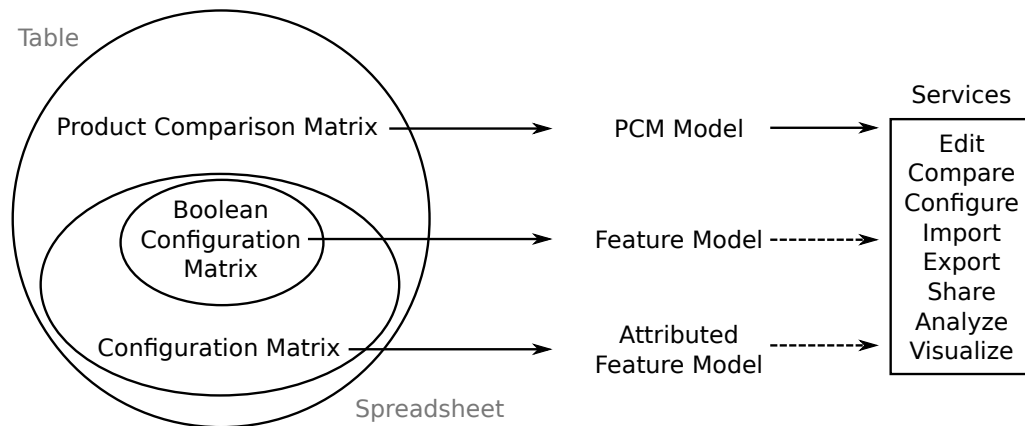

Figure 9.1: Contributions

diversity of information contained in PCMs. Despite the availability of languages and tools for AFMs, there exists no synthesis algorithm for such formalism.

In Part III, we address the two limitations of the state of the art by proposing the first algorithm for synthesizing AFMs. Our algorithm takes as input configuration matrices that can contain more than Boolean information such as numerical values or enumerations. We formally define the problem of AFM synthesis and evaluate the theoretical and practical complexity of our algorithm. We also highlight that an AFM presents extra complexity compared to a Boolean FM. Yet, our evaluation on both random and realistic configuration matrices shows that our algorithm scales up to matrices containing 2,000 attributed features, and 200,000 distinct configurations in a couple of minutes.

Our procedure is sound and complete and produces AFMs that presents a meaningful hierarchy. We develop six heuristics based on syntactical similarity, semantical similarity and general ontologies (WordNet and Wikipedia). These heuristics help a user in choosing the best parent-child relations in the hierarchy of the FM. If needs be, a branching algorithm can automatically compute an FM based on these heuristics.

Our evaluation on 126 FMs from the SPLOT repository and 30 FMs extracted from Wikipedia shows that a hybrid heuristic, exploiting logical and ontological information, performs the best. In average, a hybrid heuristic can retrieve 37.8% of parent-child relationships of the SPLOT FMs (44.4% for the PCM dataset) in one step and without any user intervention. However, we note that more than half of the parent-child relations are incorrect. This shows that a fully automated synthesis produces FMs far from the ground truth. User support is thus needed. Thanks to our heuristics, the user has to review only two parent candidates in more than half of the cases. In addition, logical constructs such as feature groups and cliques of features provide interesting information for further guiding the user in selecting the hierarchy of an FM.

Overall, our FM synthesis techniques allow a precise formalization of a class of PCMs (configuration matrices). Similarly to OpenCompare, having an FM that represents a PCM eases its exploitation. In particular, the exploitation can be based on the formally defined semantics of FMs. Moreover, this enable the use of existing services that rely on feature modeling such as model checking [172], automating product configuration [98], computing relevant information [43], communicating with stakeholders [45] or deriving software-intensive products [31].

Incidentally, our techniques also support other kinds of artifacts as input (*e.g.* source code, propositional formulas or textual requirements). As FM synthesis is a key operation in FM management, we contribute not only to our main research question but also to several operations used in product line engineering.

9.3 How to Formalize Product Comparison Matrices?

Figure 9.1 presents a summary of our contributions. Our first solution (see top of Figure 9.1) is a model-based approach that provides accurate and generic methods for formalizing PCMs. The domain metamodel precisely describes the structure and semantics of a PCM. The set of transformations is capable of encoding millions of PCMs from Wikipedia and supports common formats such as CSV and HTML. Our approach provides the basis for easing the development of services dedicated to PCMs. We developed important services such as an editor, a comparator, a configurator and statistical visualizations.

Our second solution (see middle and bottom of Figure 9.1) is a synthesis algorithm that produces precise and high quality AFMs. Due to the syntactic and semantic gap between PCM and AFMs, our algorithm is limited to a class of PCMs: configuration matrices. In addition, it may require a potentially high computational and user effort.

Our solutions provide two different views on the same PCM. On the one hand, a PCM model is product-oriented. It adopts a logical structure that is close to the original PCM. Its semantics allows the development of basic edition, manipulation and visualization techniques. On the other hand, an AFM is feature-oriented. It focuses on the variability represented by the PCM. With its precise semantics, it enables the use of advanced reasoning techniques. Moreover, the synthesis of an AFM allows to switch to product line engineering techniques for managing the set of products represented by a PCM.

Our model-based approach provides the necessary basis for editing and exploiting PCMs while our AFM synthesis algorithm is best suited for advanced reasoning on the semantics of a PCM. As a complement our first solution can be used to edit and transform PCMs into configuration matrices and thus feed our second solution. Overall, our two solutions based on metamodels and feature models are complementary approaches to the precise formalization of a large diversity of PCMs.

9.4 Towards the Formalization of Unstructured Data

As we explained previously, PCMs are an example of the numerous unstructured data available on the Web. The techniques developed in this thesis could be applied or adapted to other contexts. A first idea is to use the formalism of PCMs to represent other sources of product descriptions. For instance, we developed a tool based on OpenCompare to extract the information contained in textual descriptions of products in the form of a PCM [10]. The tool uses natural language processing techniques to perform this operation. Another example is the great number of information that the open data movement [142] is making accessible in the form of APIs or CSV files. They are also facing the need to develop software for understanding and exploiting this information. Part of this information could be encoded as a PCM and thus our contributions could ease the development of innovative services. We want to emphasize that in this context, the term *product* refers to something that has comparable characteristics. It is more generic than the term used for commercial products.

Another idea is to use our FM synthesis algorithms (see Part III) for other kinds of artifacts than configuration matrices. We already demonstrated that our FM synthesis algorithm of Chapter 7 supports various artifacts (*e.g.* source code, configuration files or textual requirements) as long as they can be encoded in a propositional formula. This contributes to several operations for software product lines. Our AFM synthesis algorithm (see Chapter 8) could also be adapted to support similar formulas. This is particularly relevant for systems like the Linux kernel which contain constraints on numerical information [140, 164]. Our algorithm could ease the analysis of variability in these systems by synthesizing a precise and meaningful AFM.

Finally, the iterative process that we propose in Chapter 4 is not restricted to PCMs. Modeling experts facing the need for formalizing a large number of complex and heterogeneous data, could reuse our process to elaborate a model-based approach. They would have to find adapted experiments for evaluating the approach based on the data, end-users and services but it would result in relevant and accurate metamodels and transformations.

All these ideas show that the contributions of this thesis are applicable to other domains than PCMs. The research domain of software engineering and in particular software product lines could benefit from our techniques.

Chapter 10

Perspectives

"A world without rules or controls, borders or boundaries. A world where anything is possible. Where we go from there is a choice I leave to you"

Neo

The work presented in this thesis opens many perspectives that we present in this chapter. First, we explore how we could further investigate the transition between a PCM and an FM (see Section 10.1). Then, we highlight challenges for the metamodeling community that we identified during the elaboration of our model-based approaches (see Section 10.2). We also show how we can pursue our analysis of the Wikipedia case study (see Section 10.3). Finally, we present the future of OpenCompare and the engineering and research challenges that we want to address (see Section 10.4).

10.1 From PCMs to FMs

10.1.1 User Effort

In Part III, we presented techniques to synthesize FMs that are sound and complete and exhibit an appropriate hierarchy. We showed that a fully automated synthesis is likely to produce feature models far from ground truth. User knowledge is thus required to obtain high quality FMs.

Measuring and managing the user effort during FM synthesis is crucial. We developed heuristics to rank parent candidates. It potentially reduce user effort during the selection of the hierarchy of an FM. We evaluated the effectiveness of our heuristics based on the position of the correct parent in the ground truth. However, we did not perform a user study to measure the user effort in a realistic setting. In addition, we showed that in some cases, the synthesis of AFM can lead to numerous constraints. This encourages us to develop techniques for presenting a relevant subset of configurations or constraints to the user.

Another challenge is to identify the situations when going from a PCM to an FM might not be desirable. For example, we could find a heuristic that, based on the shape of the PCM (*e.g.* the number of products and features), indicates if the user effort will be significant or not. Overall, we would like to measure user effort and further understand the relation between PCMs and FMs.

10.1.2 Extended Support of PCMs

In Chapter 8, we presented a technique for synthesizing AFMs from PCMs. This technique is limited to a class of PCMs that we call configuration matrices. In particular, configuration matrices do not contain uncertainty that we can encounter in some PCMs. We measured that 9.4% of the cells of PCMs from Wikipedia contain uncertainty (*NotAvailable* in our metamodel). Therefore, supporting uncertainty in the synthesis of FMs would greatly improve the support of PCMs.

The challenge is to extend the formalism of AFMs in order to support uncertainty. A first step is to identify a logic that provides the necessary constructs to define the semantics of such extended AFMs. A second step is to develop reasoners for performing operations on the model (*e.g.* checking if a product exists or if a constraint holds). One lead is the work of Czarnecki *et al.* that present probabilistic FMs [77]. It is an extension to Boolean FMs that can model soft constraints. Once the formalism is determined, we can envision to synthesize such extended AFMs from a PCM. For implementing the algorithm, we could benefit from the API provided by OpenCompare.

10.2 Metamodeling

10.2.1 Machine Learning for Metamodeling

In Part II, we presented a model-based approach for the formalization and exploitation of PCMs. To elaborate this approach, we performed lots of manual analysis and developments. We analyzed hundreds of PCMs from Wikipedia. We designed a set of metamodels. We developed regular expressions to detect types of cells. We implemented several transformations between different concrete formats and models.

Using a manual approach limits the exploration of PCMs. We are quickly overwhelmed by the number and diversity of existing PCMs. To overcome this problem, we started to automate the process. For example, we used metamorphic testing to cover the entire dataset of PCMs from Wikipedia. We think there is an opportunity to further automate the elaboration of our techniques and model-based approach in general. In particular, we envision the use of machine learning techniques to identify concepts for a metamodel from a large dataset of raw data.

We conducted a preliminary study that uses well known algorithms such as k-means [128] or latent semantic analysis [83] to perform clustering of PCM cells. The results show that we are able to retrieve some of the concepts discovered in our manual analysis. We also think there is a potential for finding new kinds of data that could be integrated in our metamodels.

Another opportunity of automation is the derivation of classifiers that can detect the types of the cells contained in a PCM (*e.g.* date, version). Such classifiers could be more flexible and accurate than our regular expressions. We plan to continue our study in order to automatically derive metamodels and their associated transformations. Even if a user seems required to guide the extraction of concepts, such automated techniques could ease the modeling of a large datasets.

10.2.2 Comparison of Model-Based Approaches

In Chapter 6, we explained how our initial approach based on a unique metamodel was not appropriate for deriving services. We noticed conflicts between our different objectives: describe the PCM domain, manipulate a PCM, edit a PCM and interoperate with other formats. For instance, a representation of a PCM based on rows and columns (appropriate for developing an editor) conflicts with a representation based on products and features (appropriate for describing the PCM domain). Therefore, we proposed another approach based on several task-specific metamodels gathered around a central domain metamodel. We highlighted how this new approach eases the creation of services compared to the initial approach. Yet the management of multiple metamodels introduces well-known synchronization problems.

We mainly based the comparison of our approaches on numerous feedback from researchers, engineers and students. However the feedback was informal and we had difficulties to quantify or formally assess the superiority of the new approach. The challenge is to define a framework for comparing model-based approaches. It would have to consider the multiplicity of metamodels and objectives. An important step would be to define measurable criteria in order to quantify the superiority of a metamodel with respect to an objective. Such criteria would need cover structural aspects (*e.g.* number of classes, associations) but also cognitive aspects (*e.g.* usability, comprehension) [105].

We think that the PCM domain can serve as a case study for the elaboration of such framework. By providing all the models and source code of OpenCompare in a freely accessible repository, we hope that other solutions will be developed and compared.

10.3 Wikipedia Case Study

In this thesis, we often relied on Wikipedia either as a knowledge base for our techniques or as a source of PCMs. Wikipedia is an interesting case study for the domain of PCMs. We would like to further understand how contributors of Wikipedia create and edit PCMs. To do so, we want to push further the analysis of our Wikipedia dataset by analyzing the evolution of PCMs over time. Furthermore, we want to understand if Wikipedia contributors use external tools to edit tables and PCMs in particular. This work could motivate and prioritize the development of services or formalisms in OpenCompare.

We had the opportunity to discuss with a small community of contributors of Wikipedia. We presented our work on OpenCompare and they seemed very interested in the project and the benefits it could bring to the encyclopedia. An interesting challenge would be to adapt and integrate the editor or some services of OpenCompare in MediaWiki, the project that supports Wikipedia. We would gain immediate and valuable feedback about our models and services as well as a large number of users.

Finally, a particularity of the syntax of Wikipedia pages, the wikitext language, is to provide a mechanism called templates. Templates are a kind of macros that provide a way to reuse existing parts of Wikipedia. We noticed that they are often used in PCMs. Therefore, we would like to better understand how they are used in this context. From this study, we may be able to improve their support in our importer and exporter for Wikipedia.

10.4 OpenCompare

OpenCompare is a first step towards the creation of a community of contributors and users of PCMs. A strong motivation is to gather feedback from this community in order to improve OpenCompare. As they are end-users of our services, they could give us precious insights on the usability or relevance of our metamodels and services. We could use this information to guide the development of a better domain metamodel for PCMs, a better API or an oracle for testing OpenCompare. To support this community, we need to fully support collaboration in the services of OpenCompare and in particular in its editor. We may face several engineering and research challenges.

A first challenge is the development of version control for PCMs. The ability to track the different versions of a PCM is essential in a collaborative context. A related feature is to be able to compute the difference between two versions and present it in an intelligible way. We already implemented a basic *diff* operation in the API of OpenCompare but we could improve it.

An important feature for a community is to be able to search and discover PCMs. One way to do that is to present PCMs related to a given one. This is particularly relevant for completing the information that a user seeks with complementary PCMs. Das Sarma *et al.* developed a technique for ranking similar tables [79]. In particular, they exploit the similarity of entities and schemas. Moreover, they also considered Wikipedia as a source of tables for their evaluation. We could adapt their technique to PCMs by deriving a schema from features and products.

One application of finding related PCMs is to provide an auto-complete mechanism. The idea is to suggest products, features or cells that could be related to the PCM under edition. Potentially, the contributors only have to review the suggested information instead of searching it. Therefore, it can ease the creation, completion or correction of a PCM. In addition to related PCMs, we could exploit Web APIs or databases as a source of knowledge.

To further help users of OpenCompare to quickly search and explore PCMs, we would like to provide a summary of the information they contain. For example, it could be presented as a text or an infographic generated automatically from a PCM. The challenge here is to find important facts in a PCM that could summarize the essential information it contains.

Finally, the information contained in PCMs is likely to change over time. To avoid a tedious search and correction of outdated information, we could link cells to external and dynamic sources. For instance, the price of a product could be retrieved from the API of a commercial website.

By integrating these numerous operations and services in OpenCompare, we get closer to the expressiveness of spreadsheets. It questions the integration of OpenCompare with spreadsheets. If

we tightly connect OpenCompare to the world of spreadsheets, we may benefit from the existing operations and community of tools such as Excel or Tableau.

We think that all these innovative services could further improve the current practice for editing and using PCMs. This thesis is the necessary step to provide abstractions and formalization techniques on which we can build these innovative services.

Part V

Appendices

Appendix A

Detailed Results of Statistical Tests

Numerous statistical tests were performed to evaluate our FM synthesis algorithm and heuristics (see Section 7.5 for further details). In this appendix, we present the comprehensive results of the tests. In particular, we report all the p-values and effect sizes that were computed.

There are two kinds of tables in this appendix. The first kind compares ontological techniques (displayed on top of the table) to purely logical techniques (displayed on the left of the table). The p-value corresponds to the comparison of an ontological technique with a logical one. The effect size is the difference between the mean score of the ontological technique and the mean score of the logical one. It means that if the effect size is positive, the ontological technique outperforms the logical one whereas if the effect size is negative, it is the opposite relation.

The second kind of tables compares each heuristic performing on the complete BIG with the same heuristic on the reduced BIG. The p-value corresponds to this comparison and the effect size is the difference between the mean score of the heuristic on the reduced BIG and the mean score on the complete BIG. It means that if the effect size is positive, the same heuristic performs better on the reduced BIG than on the complete BIG. If the effect size is negative, the reduced BIG has a negative impact on the heuristic.

Each table is related as follows to an hypothesis in Section 7.5:

- H1** Table A.1a compares FMONTO with FMRAND_{BIG} for automatically synthesizing an FM while Table A.1b compares FMONTO_{LOGIC} with FMRAND_{RBIG}.
- H2** Table A.2 compares FMRAND_{BIG} and FMONTO with respectively FMRAND_{RBIG} and FMONTO_{LOGIC} on the fully automated synthesis.
- H3** Table A.3a compares FMONTO with FMRAND_{BIG} for computing ranking lists while Table A.3b compares FMONTO_{LOGIC} with FMRAND_{RBIG}.
- H4** Table A.4 compares FMRAND_{BIG} and FMONTO with respectively FMRAND_{RBIG} and FMONTO_{LOGIC} on the computation of ranking lists.
- H5** Table A.5a (resp. Table A.5c) compares FMONTO with FMRAND_{BIG} on the percentage of correct clusters (resp. percentage of features in a correct cluster) generated by the heuristics. Table A.5b and A.5d present the same results but for FMONTO_{LOGIC} and FMRAND_{RBIG}.
- H6** Table A.6a compares FMRAND_{BIG} and FMONTO with respectively FMRAND_{RBIG} and FMONTO_{LOGIC} on the percentage of generated correct clusters. Table A.6b presents the same comparison but for the percentage of features in a correct cluster.
- H7** Table A.7a compares the percentage of correct feature groups generated from the BIG with feature groups generated from the reduced BIG. Table A.7b presents the same comparison but for the percentage of features in a correct group.

Table A.1: H1 - Full synthesis

(a) Full synthesis with BIG

Reference	Data set	Result	Ontological techniques (FMONTO)					
			SW	L	WP	PL	Wiki	Wikt
FMRAND _{BIG}	SPLOT	p-value	0.005	0.226	0.003	0.000	0.000	0.002
		effect size	7.9	6.0	8.2	9.5	8.5	7.6
	PCM	p-value	0.005	0.341	0.192	0.046	0.002	0.043
		effect size	8.1	3.5	4.9	7.4	10.4	6.9

(b) Full synthesis with a reduced BIG (● means that the approach cannot be applied due to performance issues)

Reference	Data set	Result	Ontological techniques (FMONTO _{LOGIC})					
			SW	L	WP	PL	Wiki	Wikt
FMRAND _{RBIG}	SPLOT	p-value	0.041	0.409	0.066	0.010	0.012	0.045
		effect size	5.7	3.6	5.2	6.5	6.2	5.4
	PCM	p-value	0.511	0.909	0.700	0.483	0.350	0.641
		effect size	3.1	-0.1	2.6	3.6	4.4	2.2
FMFASE	SPLOT	p-value	0.840	0.474	0.939	0.544	0.644	0.876
		effect size	0.8	-1.2	0.4	1.6	1.3	0.6
	PCM	p-value	●					
		effect size	●					
FMFASE _{SAT}	SPLOT	p-value	0.054	0.393	0.086	0.021	0.028	0.055
		effect size	5.0	3.0	4.5	5.8	5.5	4.7
	PCM	p-value	0.633	0.812	0.829	0.620	0.438	0.761
		effect size	3.3	0.0	2.7	3.7	4.5	2.3

Table A.2: H2 - Full synthesis (BIG vs reduced BIG)

Data set	Result	Pure logical techniques	Ontological techniques (FMONTO)					
		FMRAND _{BIG}	SW	L	WP	PL	Wiki	Wikt
SPLOT	p-value	0.000	0.004	0.009	0.013	0.010	0.003	0.004
	effect size	10.4	8.2	8.0	7.4	7.4	8.0	8.2
PCM	p-value	0.000	0.000	0.001	0.000	0.000	0.002	0.000
	effect size	24.1	19.1	20.5	21.8	20.3	18.1	19.5

Table A.3: H3 - Top 2

(a) Top 2 with BIG

Reference	Data set	Result	Ontological techniques (FMONTO)					
			SW	L	WP	PL	Wiki	Wikt
FMRAND _{BIG}	SPLOT	p-value	0.021	0.022	0.007	0.000	0.007	0.009
		effect size	7.0	6.5	8.7	10.3	8.4	7.2
	PCM	p-value	0.103	0.213	0.343	0.065	0.021	0.246
		effect size	7.5	5.0	4.7	7.4	9.4	5.7

(b) Top 2 with a reduced BIG

Reference	Data set	Result	Ontological techniques (FMONTO _{LOGIC})					
			SW	L	WP	PL	Wiki	Wikt
FMRAND _{RBIG}	SPLOT	p-value	0.126	0.161	0.076	0.016	0.073	0.105
		effect size	4.8	4.0	5.5	7.4	5.6	4.9
	PCM	p-value	0.569	0.980	0.695	0.417	0.483	0.783
		effect size	2.7	0.8	2.8	4.1	3.4	2.0

Table A.4: H4 - Top 2 (BIG vs reduced BIG)

Data set	Result	Pure logical techniques	Ontological techniques (FMONTO)					
		FMRAND _{BIG}	SW	L	WP	PL	Wiki	Wikt
SPLOT	p-value	0.004	0.048	0.059	0.082	0.060	0.109	0.045
	effect size	8.6	6.4	6.1	5.4	5.7	5.7	6.3
PCM	p-value	0.000	0.015	0.016	0.004	0.008	0.031	0.006
	effect size	19.9	15.1	15.7	18.0	16.5	14.0	16.3

Table A.5: H5 - Clusters generated by heuristics

(a) Percentage of correct clusters with BIG

Reference	Data set	Result	Ontological techniques (FMONTO)					
			SW	L	WP	PL	Wiki	Wikt
FMRAND _{BIG}	SPLOT	p-value	0.000	0.000	0.000	0.000	0.000	0.000
		effect size	22.7	27.6	29.6	39.9	26.9	39.1
	PCM	p-value	0.000	0.000	0.000	0.000	0.000	0.000
		effect size	34.7	47.7	45.9	64.3	38.9	56.1

(b) Percentage of correct clusters with a reduced BIG

Reference	Data set	Result	Ontological techniques (FMONTO _{LOGIC})					
			SW	L	WP	PL	Wiki	Wikt
FMRAND _{RBIG}	SPLOT	p-value	0.000	0.000	0.000	0.000	0.000	0.000
		effect size	25.1	26.1	23.6	32.0	26.3	33.6
	PCM	p-value	0.000	0.000	0.000	0.000	0.000	0.000
		effect size	31.5	39.2	36.6	52.5	35.6	48.9

(c) Percentage of features in a correct cluster with BIG

Reference	Data set	Result	Ontological techniques (FMONTO)					
			SW	L	WP	PL	Wiki	Wikt
FMRAND _{BIG}	SPLOT	p-value	0.000	0.000	0.678	0.545	0.008	0.036
		effect size	10.0	12.1	0.6	2.9	6.8	5.6
	PCM	p-value	0.000	0.000	0.944	0.000	0.000	0.000
		effect size	22.5	28.9	0.4	10.3	12.0	19.7

(d) Percentage of features in a correct cluster with a reduced BIG

Reference	Data set	Result	Ontological techniques (FMONTO _{LOGIC})					
			SW	L	WP	PL	Wiki	Wikt
FMRAND _{RBIG}	SPLOT	p-value	0.000	0.000	0.793	0.812	0.033	0.111
		effect size	8.8	11.3	0.9	1.9	6.0	4.6
	PCM	p-value	0.000	0.000	0.944	0.000	0.000	0.000
		effect size	22.3	28.7	0.5	10.4	11.9	19.8

Table A.6: H6 - Clusters generated by heuristics (BIG vs reduced BIG)

(a) Percentage of correct clusters

Data set	Result	Pure logical techniques	Ontological techniques (FMONTO)					
		FMRAND _{BIG}	SW	L	WP	PL	Wiki	Wikt
SPLOT	p-value	0.000	0.000	0.002	0.111	0.191	0.001	0.040
	effect size	13.4	15.8	12.0	7.4	5.5	12.8	8.0
PCM	p-value	0.000	0.001	0.002	0.045	0.007	0.001	0.001
	effect size	21.9	18.6	13.3	12.5	10.1	18.6	14.7

(b) Percentage of features in a correct cluster

Data set	Result	Pure logical techniques	Ontological techniques (FMONTO)					
		FMRAND _{BIG}	SW	L	WP	PL	Wiki	Wikt
SPLOT	p-value	0.220	0.294	0.506	0.694	0.348	0.403	0.375
	effect size	-1.1	-2.3	-1.8	-0.8	-2.1	-1.9	-2.1
PCM	p-value	0.866	0.956	0.962	0.950	0.997	0.915	1.000
	effect size	-0.1	-0.4	-0.3	-0.1	-0.1	-0.3	0.0

Table A.7: H7 - Feature groups (BIG vs reduced BIG)

(a) Percentage of correct clusters

Data set	Result	All groups	Mutex	Xor
SPLOT	p-value	0.008	0.010	0.257
	effect size	10.7	27.4	3.0
PCM	p-value	0.024	0.051	0.233
	effect size	7.8	8.5	8.9

(b) Percentage of features in a correct cluster

Data set	Result	All groups	Mutex	Xor
SPLOT	p-value	0.398	0.013	0.143
	effect size	-3.7	-3.2	-5.2
PCM	p-value	0.761	0.395	0.670
	effect size	3.6	-7.3	2.7

Appendix B

Theoretical Analysis of AFM Synthesis Algorithm

Our algorithm presented in Section 8.3, page 105 addresses the synthesis problem defined in Definition 21. This definition states that the synthesized AFM must be maximal and have the same configuration semantics as the input configuration matrix. In the following, we check these two properties. We also evaluate the scalability of our algorithm by analyzing its theoretical time complexity.

B.1 Soundness and Completeness

Synthesizing an AFM that represents the exact same set of configurations (*i.e.* configuration semantics) as the input configuration matrix is primordial. In order to ensure this property, the synthesis algorithm must be sound (see Definition 18) and complete (see Definition 19).

B.1.1 Valid and Comprehensive Computation of Binary Implications

An AFM can be seen as the representation of a set of configurations (see Definition 17) but also as a set of constraints over the features and attributes. These two views are equivalent but present two opposite reasonings. The former view focuses on adding configurations while the latter focuses on removing configurations. In the following, we will switch from one view to the other in order to prove the soundness and completeness of our algorithm.

A central operation in our algorithm is the computation of all the binary implications that are present in the input configuration matrix. The soundness and completeness of our algorithm are tied to a valid and comprehensive computation of these constraints. Definition 23 and Definition 24 define these two properties for the computation of binary implications, respectively.

Definition 23 (Validity of binary implications). *Let \mathbf{C} be an $M \times N$ configuration matrix. A set of binary implications BI is valid w.r.t. \mathbf{C} , iff for each $\langle i, j, u, S \rangle \in BI$ the following condition holds:*

$$\forall k \in [1..M]. (c_{k,i} = u) \Rightarrow c_{k,j} \in S \quad (\text{B.1})$$

Definition 24 (Comprehensiveness of binary implications). *Let \mathbf{C} be an $M \times N$ configuration matrix. A set of binary implications BI is comprehensive w.r.t. \mathbf{C} , iff:*

$$\forall i, j \in [1..N], \forall u \in D_i. \exists \langle i, j, u, S \rangle \in BI \text{ such that } S \subseteq D_j : \quad (\text{B.2})$$

Intuitively, for each possible combination of i, j , and u , at least one binary implication exists in BI .

Let \mathbf{C} be an $M \times N$ configuration matrix. The set of binary implications BI computed using Algorithm 2 is valid and comprehensive with respect to \mathbf{C} . The proof of these two properties is as follows:

Validity: Let $\langle i, j, u, S \rangle$ be an arbitrary binary implication in BI . In line 5 and 8 of the algorithm, we add the value of column j for configuration c_k (noted as $c_{k,j}$) to $S(i, j, c_{k,i})$. This

particular S is bound to i , j and the value of the column i for the configuration c_k (noted as $c_{k,i}$). As a result, for each $k \in [1..M]$ such that $c_{k,i} = u$, $c_{k,j}$ is in S , and Equation B.1 holds for $\langle i, j, u, S \rangle$.

Comprehensiveness: The for statements in lines 2 and 3 iterate over all values of i , j and u , and generate all distinct combinations (i, j, u) . For each of these combinations, line 4 ensures that one binary implication is added to BI . Let $\langle i, j, u, S \rangle$ be a binary implication in BI . In addition, line 5 and 8 guarantee that the value added to S is in D_j and thus $S \subseteq D_j$. Therefore, Equation B.2 holds for BI .

B.1.2 Proof of Soundness of the Synthesis Algorithm

According to Definition 18, the algorithm detailed in Section 8.3 is sound if all the configurations represented by the AFM exist also in the configuration matrix. To prove this property, it is equivalent to show that the constraints represented by the configuration matrix are included in the constraints represented by the AFM.

In general, the attributed feature diagram (see Definition 15) is not expressive enough to represent the constraints of the configuration matrix (see Section 8.2.2). To keep the algorithm sound, we rely on the additional constraint Φ of the AFM. A simple strategy is to use Equation 8.1 to specify the whole configuration matrix as a constraint, and include it in the AFM as Φ . Such a constraint would, by construction, restrict the configuration semantics of the AFM to a subset of the configuration semantics of the matrix. Therefore, our algorithm is sound if Φ is carefully defined. Otherwise, it may represent an overapproximation of the input configuration matrix (see Section 8.2.2).

B.1.3 Proof of Completeness of the Synthesis Algorithm

To prove the completeness of our algorithm, we have to show that all the configurations represented by the configuration matrix exist also in the synthesized AFM (see Definition 19). It is equivalent to show that all the constraints represented by the AFM are included in the constraints represented by the configuration matrix. A first observation is that, apart from or-groups, xor-groups and Φ , the AFM is constructed from a set of binary implications computed by Algorithm 2 (step 2 of Algorithm 1).

As proved in Section B.1.1, the computed binary implications are valid. Therefore, all the constraints presented by these implications are included in the configuration matrix. All the subsequent computations relying on the binary implications do not introduce new constraints. They only reuse and transform these binary implications into feature modeling concepts.

For or-groups and xor-groups, we reuse existing techniques that rely on the input configuration matrix. These techniques are designed for a similar context of FM synthesis and ensure the completeness of the resulting FM [29, 166]. In our context of AFMs, the features and the attributes are separated in two distinct sets, respectively F and A . Moreover, the attributes do not enter in the definition of the hierarchy H or the feature groups. As a consequence, the adaptation of techniques for computing or-groups and xor-groups to the context of AFMs is straightforward and guarantees the completeness.

Finally, Φ as computed by Equation 8.1 is equivalent to the configuration matrix. Therefore, adding such a Φ to AFM does not exclude from it any of the configurations represented by the configuration matrix.

Overall, each step of the algorithm of Section 8.3 guarantees the property of completeness. Therefore, the whole synthesis process ensures completeness.

B.2 Maximality

Another challenge is to ensure the maximality of the synthesized AFM in order to avoid trivial answers to the AFM synthesis problem (see Section 8.3). In this section, we prove that Algorithm 1 produces a maximal attributed feature model. This is stated in Theorem 1.

Theorem 1 (Maximality of the configuration semantics). *Let M be a configuration matrix, and AFM be a sound and complete synthesis of M , generated using Algorithm 1. Then, AFM is also maximal.*

Proof. To prove the maximality of $AFM = \langle F, H, E_m, G_{MTX}, G_{XOR}, G_{OR}, A, D, \delta\alpha, RC \rangle$, we show that all conditions in Definition 20 hold for AFM :

H connects every feature in F . The algorithm ensures that the synthesized hierarchy contains all the features of the configuration matrix. The hierarchy is a rooted tree which is extracted from the binary implication graph (BIG) in step 4 of Algorithm 1. By construction (see Definition 22), the BIG contains all the features. Moreover, the comprehensive computation of the binary implications (see Section B.1.1) ensures that the BIG represents all possible implications of the configuration matrix. We can define a hierarchy of an AFM as a spanning tree of the BIG. Therefore, every spanning tree of the BIG is a possible hierarchy for the AFM and every possible hierarchy is a spanning tree of the BIG [3]. The existence of a single spanning tree is not generally ensured for a binary implication graph computed from any arbitrary configuration matrix. Specifically, the BIG may contain more than a single connected component. In such cases, we simply create a new root feature r in the BIG, and connect every feature in F to r . As a consequence, line 3 of the algorithm always generates a connected graph. The `extractHierarchy` routine in line 4 of Algorithm 1, uses the domain knowledge to chose one spanning tree of the BIG as H . Therefore, H is guaranteed to be a tree containing all features in F .

Adding an edge to E_m changes the configuration semantics of AFM ($\llbracket AFM \rrbracket$). The algorithm ensures that no edge can be added to the set of mandatory edges, E_m , without changing the configuration semantics of the AFM (i.e., adding or removing items from $\llbracket AFM \rrbracket$). E_m represents every edge (f_1, f_2) of the hierarchy H such that $f_1 \Leftrightarrow f_2$. In line 6 of the algorithm, for each edge (f_1, f_2) in the hierarchy H , we add an edge (f_2, f_1) to E_m , iff (f_2, f_1) exists in the BIG. As mentioned previously, the BIG exactly represents all possible implications of the configuration matrix. Adding any other edge to E_m implies that the added edge does not exist in BIG. Therefore, no edge can be further added to E_m without changing the configuration matrix, which corresponds to the configuration semantics of the AFM.

Adding an item to any of G_{MTX} , G_{OR} , or G_{XOR} changes $\llbracket AFM \rrbracket$. The computation of feature groups is entirely performed with existing techniques that are designed for the synthesis of boolean FMs. Our definition of a maximal AFM (see Definition 15 and 20) preserves the definition of feature groups and the notion of maximality used in boolean FMs. Moreover, the attributes are clearly separated from features and are not part of the feature groups. Therefore, the techniques designed for boolean FMs are not impacted by the attributes and keep their properties (soundness, completeness and maximality). As we are using techniques that are designed for synthesizing sound, complete and maximal boolean FMs [29, 166], no group can be added to G_{MTX} , G_{OR} or G_{XOR} without changing the configuration semantics of the AFM .

Moving any item from G_{MTX} or G_{OR} to G_{XOR} changes $\llbracket AFM \rrbracket$. An xor-group is a feature-group that is both a mutex-group and an or-group. In Algorithm 1, we promote every mutex-group that is also an or-group as an xor-group. Moreover, the previous property of maximality ensures that all the possible feature groups are computed. Therefore, moving another group from G_{MTX} or G_{OR} to G_{XOR} is impossible without changing the configuration semantics of the AFM.

Adding a non-redundant constraint to RC changes $\llbracket AFM \rrbracket$. As shown in the grammar of RC in Figure 8.4, all readable constraints are implications between values of features or attributes. We compute the set of all such binary implications in line 2 of the algorithm. As proven in Section B.1.1, Algorithm 2 perform a comprehensive computation of binary implications in BI. Any additional constraint is therefore, either redundant, forbidden by the domain knowledge (i.e. its numerical literal is not part of the interesting values) or inconsistent with configuration matrix M . The latter implies that adding a non-redundant constraint to RC would change the configuration semantics of AFM .

Overall, every property of the maximality is verified in the resulting AFM of our algorithm. \square

B.3 Complexity analysis

The manual elaboration of an AFM is error-prone and time-consuming. As we showed previously, the soundness and completeness of our algorithm address the first problem. For the second problem, we have to evaluate the time complexity of our algorithm. It depends on 3 characteristics of the input configuration matrix:

- number of variables (features + attributes): $v = f + a$
- number of configurations: c
- maximum domain size (*i.e.* maximum number of distinct values for a variable): d

In the following, we analyze the complexity for each step of Algorithm 1 and 2.

B.3.1 Extracting Features and Attributes

The first step of Algorithm 1 is the extraction of features, attributes and their domains. This extraction simply consists in running through the configuration matrix to gather the domains and identify features and attributes. The size of the matrix is characterized by the number of variables (columns) and the number of configurations (rows). Therefore, the complexity is $O(v.c)$.

B.3.2 Extracting Binary Implications

The extraction of binary implications is computed by Algorithm 2 whose complexity is as follows. The outer for loop of lines 2-8 iterates over all pairs of variables in the configuration matrix ($O(v^2)$). The inner for loop of lines 3-8 iterates over all configurations ($O(c)$). In this loop, we perform 2 types of operations: checking the existence of the set $S(i, j, c_{k,i})$ in line 4 and adding one element to a set. Checking the existence of $S(i, j, c_{k,i})$, for a given i and j , involves searching for an element in a map that has potentially d elements. Therefore, its complexity is $O(d)$. The latter operation is performed on a set that accesses its elements by a hash function. Adding an element to such a set has a complexity of $O(1)$. Overall, the complexity of the computation of binary implications is $O(v^2.c.d)$.

B.3.3 Defining the Hierarchy

In line 3, we iterate over all the binary implications to compute the binary implication graph and the mutex graph. For each binary implication, if it represents an implication between two features, we add an edge to the binary implication graph. If the binary implication represents a mutual exclusion between two features, we add an edge to the mutex graph. Both checks are done in a constant time. Therefore, the complexity of this step depends on the number of binary implications. As explained in Algorithm 2, we create a binary implication for each pair of variables (i, j) and for each value $c_{k,i}$ in the domain of the i . It results in a maximum of $v^2.d$ binary implications. As a consequence, the complexity of line 3 is $O(v^2.d)$.

In line 4, we compute the hierarchy of the AFM by selecting a tree in the binary implication graph. This step is performed by the domain knowledge (*i.e.* by a user or an external algorithm). In [3], we propose an algorithm for this task which has a time complexity of $O(f.log(f^2))$.

In line 5, we compute all the possible places for each attribute. We recall that an attribute a can be placed in the feature f if $\neg f \Rightarrow (a = 0_a)$, with 0_a being the null value of the domain of a . We first initialize the possible places for all attributes as an empty set. Then, we iterate over each binary implication $\{(i, j, u, S)\}$ in order to add the valid places. The loop has a complexity of $O(v^2.d)$ as it represents the maximum number of binary implications. A valid place is identified as follows. First, we check that i is a feature, j is an attribute and that u represents the absence of the feature i . Then, we verify that S is equal to the null value of the domain of j . If all these properties are respected, the feature i is thus a valid place for the attribute j and can be added to its possible places. These verifications have a complexity of $O(d)$. Overall, the complexity of this step is $O(v^2.d^2)$.

B.3.4 Computing the Variability Information

The computation of variability information is done in two steps: mandatory features and feature groups. For detecting mandatory features, we iterate over every edge of the hierarchy. As the hierarchy is a tree containing all the features as nodes, the number of edges is exactly equal to $f - 1$. For each edge, we check that the inverted edge exists in the binary implication graph. This check is performed with a complexity of $O(f)$ in our implementation. Overall, the complexity is $O(f^2)$.

For feature groups, we rely on existing techniques that are developed in [29,166]. We summarize the results of the complexity analysis of these techniques.

The computation of mutex groups consists in finding maximal cliques in the mutex graph. As the mutex graph contains all the features as nodes, the complexity of this operation is $O(3^{f/3})$ [176].

For or-groups, the algorithm relies on a binary integer programming which is an NP-complete problem.

For the computation of xor-groups, there are two alternatives. The first one assumes the computation of or-groups. For each or-group, it iterates through the mutex-groups to check if there exists an equivalent group (*i.e.* same parent and same children). As the number of groups is bounded by the number of features, the two iterations have a complexity of $O(f^2)$. Checking if two groups are equivalent consists in checking the equality of two sets. The maximum size for a group is also bounded by the number of features. The check is performed with a complexity of $O(f^2)$. Overall, this first technique for computing xor-groups is $O(f^4)$.

The second technique do not assume the computation of or-groups. It iterates over every mutex-group and checks that, for each configuration, the parent of the group implies the disjunction of the features of the group. Checking this property depends on the size of the mutex-group, which is bounded by the number of features f . Overall, the complexity of this second technique for computing xor-groups is $O(f^2.c)$

B.3.5 Computing Cross Tree Constraints

The computation of cross tree constraints (*RC*) is performed in three steps.

First, the *requires* constraints are extracted from the binary implication graph. The algorithm iterates over every edge of the graph and checks if it exists either in the mandatory features or in the hierarchy. The binary implication graph is composed of the features as nodes and thus contains at most f^2 edges. In addition, the number of edges represented by the mandatory features and the hierarchy is bounded by the number of features f . Therefore, the complexity of this step is $O(f^3)$.

Then, the *excludes* constraints are extracted from the mutex graph by looking for all the edges that are in the mutex graph but not in any mutex-group. The algorithm iterates over every edge of the mutex graph and checks that it does not exist in the mutex-groups. Like the binary implication graph, the mutex graph contains at most f^2 edges. Moreover, the mutex-groups represent at most f edges (size of the hierarchy). Therefore, checking if an edge exists in the mutex-groups has a complexity of $O(f)$. Overall, the complexity of this step is $O(f^3)$.

Finally, the complex constraints are extracted from the binary implications computed in line 2 of Algorithm 1. This extraction is done in two steps. In the first step, the algorithm iterates over every binary implication, which results in a complexity of $O(v^2.d)$. Then, binary implications that refer to a particular pair of attributes (e.g., (a_i, a_j)) are divided into three categories based on the bound specified on the first attribute, by the domain knowledge. The items in each category are then merged. To speed up the detection of implications that need to be merged, we store the implications in a map indexed by the pairs of attributes. Therefore, the algorithm is working on three maps that have at most v^2 elements. Thus, the complexity of an operation on the map is $O(v^2)$. Merging two binary constraints (a_i, u_1, a_j, S_1) and (a_i, u_2, a_j, S_2) consists in computing the union of S_1 and S_2 . These sets contain values of the attribute a_j and have a maximum size of d . Therefore, the complexity for merging two binary constraints is $O(d)$ and the total complexity of this first step is $O(v^2.d(v^2 + d)) = O(v^4.d + v^2.d^2)$.

In the second step of the extraction of constraints, we iterate over the three maps previously computed. Each map has potentially v^2 elements. The complexity of the loop is thus $O(v^2)$. In these maps, the value of each element (a_i, a_j) is composed of the result of the previous merge

operations, which is a set S of at most d elements. We check that S can be represented as “ a_j OP k ”, with OP a comparison operator from the grammar of RC and k a value of the domain of a_j , specifying the bound on it. If this representation is possible, we add it as a complex constraint to RC . In our implementation this check has a complexity of d^2 . Therefore, the complexity of the second step is $O(v^2.d^2)$.

Overall, the complexity of the computation of complex constraints is $O(v^4.d + v^2.d^2)$.

B.3.6 Overall Complexity

The time complexity analysis of Algorithm 1 shows that, apart from the computation of mutex-groups and or-groups, the synthesis of an attributed feature diagram has a polynomial time complexity. In particular, its complexity is $O(v^4.d + v^2.d^2 + v^2.c.d)$. The complexity of the computation of mutex-groups and or-groups are exponential and NP-complete, respectively. They represent the hardest parts of Algorithm 1 from a theoretical point of view. To obtain an AFM, we have to take into account the computation of Φ . With our algorithm in Equation 8.1, we simply iterate over each value of the configuration matrix, which results in a complexity of $O(v.c)$.

List of Figures

1.1	How to formalize product comparison matrices?	3
2.1	Description of a PCM	12
3.1	Example of a feature model of a product line for wiki software	24
3.2	Derivation of an FM from various kinds of artifacts.	26
3.3	Precision of an FM synthesis algorithm according to the input configurations (adapted from Figure 5 of [163])	27
3.4	A non maximal FM with the same configuration semantics as Figure 3.1	28
4.1	Example of a PCM in Wikipedia [65]	36
4.2	Code snippet in wikitext of the table of Figure 4.1	36
4.3	Iterative process for the elaboration of a model-based approach for PCMs	38
5.1	Global View of our Automated Formalization of PCMs	41
5.2	The PCM Metamodel	43
5.3	Example of a PCM Editor with Warnings and Filtering	50
6.1	Overview of our new approach: task-specific metamodels gathered around a central domain metamodel	54
6.2	Excerpt of the domain metamodel	54
6.3	Metamodel for API	55
6.4	Editor of OpenCompare	56
6.5	Metamodel for editor	56
6.6	Metamodel for importing and exporting PCMs	57
6.7	Excerpt of the model resulting from the import of the PCM of Figure 2.1, page 12	58
6.8	Hierarchy of features in a PCM about the comparison of AMD processors in Wikipedia	60
6.9	Services for exploring a PCM in OpenCompare	64
7.1	An FM with the same configuration semantics than fm_u ($\llbracket fm_g \rrbracket = \llbracket fm_u \rrbracket$) and the PCM of Figure 7.1a while exhibiting an appropriate ontological semantics	70
7.2	What practitioners do not want. At the bottom, a non intuitive user interface of a configurator that could have been generated from fm_u due to its doubtful ontological semantics.	72
7.3	A key issue for automated operations: numerous FMs conformant to the configuration semantics of ϕ exist but are likely to have an inappropriate ontological semantics.	73
7.4	Binary implicating graph of the formula in Figure 7.1b	76
7.5	Reduced binary implicating graph of the graph in Figure 7.4	77
7.6	Ontologic-aware feature model synthesis	79
7.7	Interface of the environment during synthesis	83
7.8	Cliques unfolding: simple versus complex	92
7.9	Logical feature groups: bi-implied features, clique contraction, parent place-holder	93
8.1	Core problem: synthesis of attributed feature model from configuration matrix	100
8.2	A configuration matrix for Wiki engines.	100

8.3	One possible attributed feature model for representing the configuration matrix in Figure 8.2	101
8.4	The grammar of readable constraints.	102
8.5	Another attributed feature model representing the configuration matrix in Figure 8.2	103
8.6	Web-based tool for gathering domain knowledge during the synthesis	104
8.7	Scalability of or-groups computation w.r.t the number of variables	109
8.8	Scalability w.r.t the number of variables	109
8.9	Scalability w.r.t the number of configurations	110
8.10	Scalability w.r.t the maximum domain size	110
8.11	Time complexity distribution for all experiments without or-groups computation .	111
8.12	Time complexity distribution of Algorithm 1 on the <i>Best Buy</i> dataset	112
8.13	Main steps for going from a PCM to an AFM	113
9.1	Contributions	121

List of Tables

3.1	Configurations of the FM of Figure 3.1	24
3.2	PCM of FM synthesis and reverse engineering techniques	31
5.1	Use of the metamodel concepts	47
5.2	Precision of our automated techniques in the evaluation of 75 PCMs	48
6.1	Statistics on the structure of PCMs	59
6.2	Use of the domain metamodel concepts	60
7.1	Synthesis techniques used for the experiments	85
7.2	Properties of FMs (average per FM)	85
7.3	Effectiveness of full synthesis (percentage of common edges)	88
7.4	Percentage of correct parents in the top 2 positions of the ranking lists (RQ2)	89
7.5	Clusters generated by heuristics (RQ2)	91
7.6	Cliques and logical feature groups as clusters	92
8.1	Statistics on the <i>Best Buy</i> dataset.	112
A.1	H1 - Full synthesis	132
A.2	H2 - Full synthesis (BIG vs reduced BIG)	132
A.3	H3 - Top 2	132
A.4	H4 - Top 2 (BIG vs reduced BIG)	133
A.5	H5 - Clusters generated by heuristics	133
A.6	H6 - Clusters generated by heuristics (BIG vs reduced BIG)	134
A.7	H7 - Feature groups (BIG vs reduced BIG)	134

Author's publications

- [1] Mathieu Acher, Guillaume Bécan, Benoit Combemale, Benoit Baudry, and Jean-Marc Jézéquel. Product lines can jeopardize their trade secrets. In *Foundations of Software Engineering*, pages 930–933, 2015.
- [2] Guillaume Bécan, Mathieu Acher, Benoit Baudry, and Sana Ben Nasr. Breathing Ontological Knowledge Into Feature Model Management. Rapport Technique RT-0441, INRIA, October 2013.
- [3] Guillaume Bécan, Mathieu Acher, Benoit Baudry, and Sana Ben Nasr. Breathing ontological knowledge into feature model synthesis: an empirical study. *Empirical Software Engineering*, pages 1–48, 2015.
- [4] Guillaume Bécan, Mathieu Acher, Jean-Marc Jézéquel, and Thomas Menguy. On the variability secrets of an online video generator. In *Workshop on Variability Modelling of Software-intensive Systems*, page 96, 2015.
- [5] Guillaume Bécan, Razieh Behjati, Arnaud Gotlieb, and Mathieu Acher. Synthesis of attributed feature models from product descriptions. In *Software Product Line Conference*, pages 1–10, 2015.
- [6] Guillaume Bécan, Razieh Behjati, Arnaud Gotlieb, and Mathieu Acher. Synthesis of attributed feature models from product descriptions: Foundations. *arXiv preprint arXiv:1502.04645*, 2015.
- [7] Guillaume Bécan, Sana Ben Nasr, Mathieu Acher, and Benoit Baudry. Webfml: synthesizing feature models everywhere. In *Software Product Line Conference: Companion Volume for Workshops, Demonstrations and Tools*, pages 112–116, 2014.
- [8] Guillaume Bécan, Sana Ben Nasr, and Benoit Baudry. An ontologic-aware feature modeling environment. In *Journées lignes de produits*, 2013.
- [9] Guillaume Bécan, Nicolas Sannier, Mathieu Acher, Olivier Barais, Arnaud Blouin, and Benoit Baudry. Automating the formalization of product comparison matrices. In *Automated software engineering*, pages 433–444, 2014.
- [10] Sana Ben Nasr, Guillaume Bécan, Mathieu Acher, João Bosco Ferreira Filho, Benoit Baudry, Nicolas Sannier, and Jean-Marc Davril. Matrixminer: a red pill to architect informal product descriptions in the matrix. In *Foundations of Software Engineering*, pages 982–985, 2015.
- [11] Jean-Marc Davril, Patrick Heymans, Guillaume Bécan, and Mathieu Acher. On breaking the curse of dimensionality in reverse engineering feature models. In *Configuration Workshop*, volume 17, 2015.
- [12] Nicolas Sannier, Guillaume Bécan, Mathieu Acher, Sana Ben Nasr, and Benoit Baudry. Comparing or configuring products: Are we getting the right ones? In *Workshop on Variability Modelling of Software-Intensive Systems*, page 9, 2014.
- [13] Nicolas Sannier, Guillaume Bécan, Sana Ben Nasr, and Benoit Baudry. On product comparison matrices and variability models from a product comparison/configuration perspective. In *Journées lignes de produits*, 2013.

Bibliography

- [14] Ebrahim Khalil Abbasi, Mathieu Acher, Patrick Heymans, and Anthony Cleve. Reverse engineering web configurators. In *Software Maintenance, Reengineering and Reverse Engineering*, pages 264–273, 2014.
- [15] Robin Abraham and Martin Erwig. Type inference for spreadsheets. In *Principles and practice of declarative programming*, pages 73–84, 2006.
- [16] Robin Abraham and Martin Erwig. Ucheck: A spreadsheet type checker for end users. *Journal of Visual Languages & Computing*, 18(1):71–95, 2007.
- [17] Robin Abraham, Martin Erwig, Steve Kollmansberger, and Ethan Seifert. Visual specifications of correct spreadsheets. In *2005 IEEE Symposium on Visual Languages and Human-Centric Computing (VL/HCC'05)*, pages 189–196. IEEE, 2005.
- [18] Mathieu Acher, Benoit Baudry, Patrick Heymans, Anthony Cleve, and Jean-Luc Hainaut. Support for reverse engineering and maintaining feature models. In *Workshop on Variability Modelling of Software-intensive Systems*, page 20, 2013.
- [19] Mathieu Acher, Anthony Cleve, Philippe Collet, Philippe Merle, Laurence Duchien, and Philippe Lahire. Reverse engineering architectural feature models. In *Software Architecture*, pages 220–235. 2011.
- [20] Mathieu Acher, Anthony Cleve, Philippe Collet, Philippe Merle, Laurence Duchien, and Philippe Lahire. Extraction and evolution of architectural variability models in plugin-based systems. *Software & Systems Modeling*, 13(4):1367–1394, 2014.
- [21] Mathieu Acher, Anthony Cleve, Gilles Perrouin, Patrick Heymans, Charles Vanbeneden, Philippe Collet, and Philippe Lahire. On extracting feature models from product descriptions. In *Workshop on Variability Modeling of Software-Intensive Systems*, pages 45–54, 2012.
- [22] Mathieu Acher, Philippe Collet, Philippe Lahire, and Robert B France. Familiar: A domain-specific language for large scale management of feature models. *Science of Computer Programming*, 78(6):657–681, 2013.
- [23] Mathieu Acher, Benoit Combemale, Philippe Collet, Olivier Barais, Philippe Lahire, and Robert B France. Composing your compositions of variability models. In *Model-Driven Engineering Languages and Systems*, pages 352–369. 2013.
- [24] Marco D Adelfio and Hanan Samet. Schema extraction for tabular data on the web. *VLDB Endowment*, 6(6):421–432, 2013.
- [25] Alvin Ahnassay, Ebrahim Bagheri, and Dragan Gasevic. Empirical evaluation in software product line engineering. Technical report, Tech. Rep. TR-LS3-130084R4T, Laboratory for Systems, Software and Semantics, Ryerson University, 2013.
- [26] Alfred V. Aho, Michael R Garey, and Jeffrey D. Ullman. The transitive reduction of a directed graph. *SIAM Journal on Computing*, 1(2):131–137, 1972.
- [27] Algorithm of Haslinger et al. [101]. <http://www.jku.at/sea/content/e139529/e126342/e188736/>.

- [28] Vander Alves, Christa Schwanninger, Luciano Barbosa, Awais Rashid, Peter Sawyer, Paul Rayson, Christoph Pohl, and Andreas Rummler. An exploratory study of information retrieval techniques in domain analysis. In *Software Product Line Conference*, pages 67–76, 2008.
- [29] Nele Andersen, Krzysztof Czarnecki, Steven She, and Andrzej Wąsowski. Efficient synthesis of feature models. In *Software Product Line Conference*, pages 106–115, 2012.
- [30] Michal Antkiewicz, Thiago Tonelli Bartolomei, and Krzysztof Czarnecki. Automatic extraction of framework-specific models from framework-based application code. In *Automated software engineering*, pages 214–223, 2007.
- [31] Sven Apel, Don Batory, Christian Kästner, and Gunter Saake. *Feature-Oriented Software Product Lines*. Springer, 2013.
- [32] Sven Apel and Christian Kästner. An overview of feature-oriented software development. *Journal of Object Technology*, 8(5):49–84, 2009.
- [33] Sven Apel, Christian Kastner, and Christian Lengauer. Language-independent and automated software composition: The featurehouse experience. *Transactions on Software Engineering*, 39(1):63–79, 2013.
- [34] Sven Apel, Alexander von Rhein, Philipp Wendler, Armin Größlinger, and Dirk Beyer. Strategies for product-line verification: Case studies and experiments. In *International Conference on Software Engineering*, pages 482–491, 2013.
- [35] Andrea Arcuri and Lionel Briand. A practical guide for using statistical tests to assess randomized algorithms in software engineering. In *International Conference on Software Engineering*, pages 1–10, 2011.
- [36] Franz Baader and Werner Nutt. The description logic handbook. chapter Basic Description Logics, pages 43–95. 2003.
- [37] Ebrahim Bagheri, Faezeh Ensan, and Dragan Gasevic. Decision support for the software product line domain engineering lifecycle. *Automated Software Engineering*, 19(3):335–377, 2012.
- [38] Ebrahim Bagheri and Dragan Gasevic. Assessing the maintainability of software product line feature models using structural metrics. *Software Quality Journal*, 19(3):579–612, 2011.
- [39] Kacper Bąk, Krzysztof Czarnecki, and Andrzej Wąsowski. Feature and meta-models in clafér: mixed, specialized, and coupled. In *Software Language Engineering*, pages 102–122. 2011.
- [40] Kacper Bąk, Dina Zayan, Krzysztof Czarnecki, Michał Antkiewicz, Zinovy Diskin, Andrzej Wąsowski, and Derek Rayside. Example-driven modeling: model= abstractions+ examples. In *International Conference on Software Engineering*, pages 1273–1276, 2013.
- [41] Don Batory. Feature modularity for product-lines. *Tutorial at: OOPSLA*, 6, 2006.
- [42] Don Batory, David Benavides, and Antonio Ruiz-Cortés. Automated analysis of feature models: challenges ahead. *Communications of the ACM*, 49(12):45–47, 2006.
- [43] David Benavides, Sergio Segura, and Antonio Ruiz-Cortés. Automated analysis of feature models 20 years later: A literature review. *Information Systems*, 35(6):615–636, 2010.
- [44] David Benavides, Sergio Segura, Pablo Trinidad, and Antonio Ruiz Cortés. Fama: Tooling a framework for the automated analysis of feature models. *Workshop on Variability Modelling of Software-Intensive Systems*, 2007:01, 2007.
- [45] Thorsten Berger, Divya Nair, Ralf Rublack, Joanne M Atlee, Krzysztof Czarnecki, and Andrzej Wąsowski. Three cases of feature-based variability modeling in industry. In *Model-Driven Engineering Languages and Systems*, pages 302–319. 2014.

- [46] Thorsten Berger, Ralf Rublack, Divya Nair, Joanne M Atlee, Martin Becker, Krzysztof Czarnecki, and Andrzej Wasowski. A survey of variability modeling in industrial practice. In *International Workshop on Variability Modelling of Software-intensive Systems*, page 7, 2013.
- [47] Thorsten Berger, Steven She, Roberto Lotufo, Andrzej Wasowski, and Krzysztof Czarnecki. A study of variability models and languages in the systems software domain. *IEEE Transactions on Software Engineering*, 39(12):1611–1640, 2013.
- [48] Quentin Boucher, Ebrahim Khalil Abbasi, Arnaud Hubaux, Gilles Perrouin, Mathieu Acher, and Patrick Heymans. Towards more reliable configurators: A re-engineering perspective. In *Workshop on Product Line Approaches in Software Engineering*, pages 29–32, 2012.
- [49] Alexander Budanitsky and Graeme Hirst. Evaluating wordnet-based measures of lexical semantic relatedness. *Computational Linguistics*, 32(1):13–47, 2006.
- [50] Michael J Cafarella, Alon Halevy, Daisy Zhe Wang, Eugene Wu, and Yang Zhang. Webtables: exploring the power of tables on the web. *VLDB Endowment*, 1(1):538–549, 2008.
- [51] Michael J Cafarella, Alon Y Halevy, Yang Zhang, Daisy Zhe Wang, and Eugene Wu. Uncovering the relational web. In *WebDB*, 2008.
- [52] Paolo M Camerini, Luigi Fratta, and Francesco Maffioli. A note on finding optimum branchings. *Networks*, 9(4):309–312, 1979.
- [53] Javier Canovas and Jordi Cabot. Discovering implicit schemas in json data. In *International Conference on Web Engineering*, 2013.
- [54] Jessie Carbonnel, Marianne Huchard, and Alain Gutierrez. Variability representation in product lines using concept lattices: feasibility study with descriptions from wikipedia’s product comparison matrices. In *International Conference on Formal Concept Analysis*, page 16, 2015.
- [55] José María Cavanillas, Edward Curry, and Wolfgang Wahlster. New horizons for a data-driven economy.
- [56] Chris Chambers and Martin Erwig. Automatic detection of dimension errors in spreadsheets. *Journal of Visual Languages & Computing*, 20(4):269–283, 2009.
- [57] Hsin-Hsi Chen, Shih-Chung Tsai, and Jin-He Tsai. Mining tables from large scale html texts. In *Computational linguistics*, pages 166–172, 2000.
- [58] Kun Chen, Wei Zhang, Haiyan Zhao, and Hong Mei. An approach to constructing feature models based on requirements clustering. In *International Conference on Requirements Engineering*, pages 31–40, 2005.
- [59] Tsong Yueh Chen, Tsun Him Tse, and Z Quan Zhou. Fault-based testing without the need of oracles. *Information and Software Technology*, 45(1):1–9, 2003.
- [60] Andreas Classen, Quentin Boucher, and Patrick Heymans. A text-based approach to feature modelling: Syntax and semantics of tvl. *Science of Computer Programming*, 76(12):1130–1143, 2011.
- [61] Andreas Classen, Patrick Heymans, and Pierre-Yves Schobbens. What’s in a feature: A requirements engineering perspective. In *International Conference on Fundamental Approaches to Software Engineering*, pages 16–30. Springer, 2008.
- [62] Andreas Classen, Patrick Heymans, Pierre-Yves Schobbens, and Axel Legay. Symbolic model checking of software product lines. In *International Conference on Software Engineering*, pages 321–330, 2011.

- [63] Andreas Classen, Patrick Heymans, Pierre-Yves Schobbens, Axel Legay, and Jean-François Raskin. Model checking lots of systems: efficient verification of temporal properties in software product lines. In *International Conference on Software Engineering*, pages 335–344, 2010.
- [64] Edgar F Codd. A relational model of data for large shared data banks. *Communications of the ACM*, 13(6):377–387, 1970.
- [65] Comparison of Web Conferencing Software. https://en.wikipedia.org/wiki/Comparison_of_web_conferencing_software.
- [66] Maxime Cordy, Pierre-Yves Schobbens, Patrick Heymans, and Axel Legay. Beyond boolean product-line model checking: dealing with feature attributes and multi-features. In *International Conference on Software Engineering*, pages 472–481, 2013.
- [67] Jesús Sánchez Cuadrado, Juan de Lara, and Esther Guerra. Bottom-up meta-modelling: An interactive approach. In *Model Driven Engineering Languages and Systems*, pages 3–19, 2012.
- [68] Jácome Cunha, Martin Erwig, and Joao Saraiva. Automatically inferring classsheet models from spreadsheets. In *Visual Languages and Human-Centric Computing*, pages 93–100, 2010.
- [69] Jácome Cunha, João P Fernandes, Hugo Ribeiro, and João Saraiva. Towards a catalog of spreadsheet smells. In *Computational Science and Its Applications*, pages 202–216. Springer, 2012.
- [70] Jácome Cunha, João Paulo Fernandes, Jorge Mendes, and João Saraiva. Mdsheet: A framework for model-driven spreadsheet engineering. In *International Conference on Software Engineering*, pages 1395–1398, 2012.
- [71] Krzysztof Czarnecki, Thomas Bednasch, Peter Unger, and Ulrich Eisenecker. Generative programming for embedded software: An industrial experience report. In *Generative Programming and Component Engineering*, pages 156–172. Springer, 2002.
- [72] Krzysztof Czarnecki and Ulrich Eisenecker. *Generative Programming: Methods, Tools, and Applications*. 2000.
- [73] Krzysztof Czarnecki, Simon Helsen, and Ulrich Eisenecker. Staged configuration using feature models. In *Software Product Lines*, pages 266–283. 2004.
- [74] Krzysztof Czarnecki, Simon Helsen, and Ulrich Eisenecker. Formalizing cardinality-based feature models and their specialization. *Software process: Improvement and practice*, 10(1):7–29, 2005.
- [75] Krzysztof Czarnecki, Chang Hwan, Peter Kim, and KT Kalleberg. Feature models are views on ontologies. In *Software Product Line Conference*, pages 41–51, 2006.
- [76] Krzysztof Czarnecki and Krzysztof Pietroszek. Verifying feature-based model templates against well-formedness ocl constraints. In *Generative programming and component engineering*, pages 211–220, 2006.
- [77] Krzysztof Czarnecki, Steven She, and Andrzej Wa Sowski. Sample spaces and feature models: There and back again. In *Software Product Line Conference*, pages 22–31, 2008.
- [78] Krzysztof Czarnecki and Andrzej Wasowski. Feature diagrams and logics: There and back again. In *Software Product Line Conference*, pages 23–34, 2007.
- [79] Anish Das Sarma, Lujun Fang, Nitin Gupta, Alon Halevy, Hongrae Lee, Fei Wu, Reynold Xin, and Cong Yu. Finding related tables. In *International Conference on Management of Data*, pages 817–828, 2012.

- [80] Jean-Marc Davril, Edouard Delfosse, Negar Hariri, Mathieu Acher, Jane Cleland-Huang, and Patrick Heymans. Feature model extraction from large collections of informal product descriptions. In *Foundations of Software Engineering*, pages 290–300, 2013.
- [81] Christian Dietrich, Reinhard Tartler, Wolfgang Schröder-Preikschat, and Daniel Lohmann. A robust approach for variability extraction from the linux build system. In *Software Product Line Conference*, pages 21–30, 2012.
- [82] Documentation of the visual editor of MediaWiki. <https://www.mediawiki.org/wiki/VisualEditor/Portal>.
- [83] Susan T Dumais, George W Furnas, Thomas K Landauer, Scott Deerwester, and Richard Harshman. Using latent semantic analysis to improve access to textual information. In *Human factors in computing systems*, pages 281–285, 1988.
- [84] Holger Eichelberger and Klaus Schmid. Mapping the design-space of textual variability modeling languages: a refined analysis. *International Journal on Software Tools for Technology Transfer*, pages 1–26, 2014.
- [85] David W Embley, Matthew Hurst, Daniel Lopresti, and George Nagy. Table-processing paradigms: a research survey. *International Journal of Document Analysis and Recognition*, 8(2-3):66–86, 2006.
- [86] Gregor Engels and Martin Erwig. Classsheets: automatic generation of spreadsheet applications from object-oriented specifications. In *Automated software engineering*, pages 124–133, 2005.
- [87] FAMILIAR: FeAture Model scrIPt Language for manIPulation and Automatic Reasoning. <http://nyx.unice.fr/projects/familiar/>.
- [88] Martin Faunes, Juan Cadavid, Benoit Baudry, Houari Sahraoui, and Benoit Combemale. Automatically searching for metamodel well-formedness rules in examples and counter-examples. In *Model-Driven Engineering Languages and Systems*, pages 187–202. 2013.
- [89] Alessio Ferrari, Giorgio O Spagnolo, and Felice Dell’Orletta. Mining commonalities and variabilities from natural language documents. In *Software Product Line Conference*, pages 116–120, 2013.
- [90] Marc Fisher and Gregg Rothermel. The euses spreadsheet corpus: a shared resource for supporting experimentation with spreadsheet dependability mechanisms. In *ACM SIGSOFT Software Engineering Notes*, volume 30, pages 1–5. ACM, 2005.
- [91] Martin Fowler. Refactoring: Improving the design of existing code. In *11th European Conference. Jyväskylä, Finland*, 1997.
- [92] Robert France, Indrakshi Ray, Geri Georg, and Sudipto Ghosh. Aspect-oriented approach to early design modelling. In *IEE Proceedings-Software*, volume 151, pages 173–185, 2004.
- [93] Robert France and Bernhard Rumpe. Model-driven development of complex software: A research roadmap. In *Future of Software Engineering*, pages 37–54, 2007.
- [94] Mārtiņš Francis, Dimitrios S Kolovos, Nicholas Matragkas, and Richard F Paige. Adding spreadsheets to the mde toolkit. In *Model-Driven Engineering Languages and Systems*, pages 35–51. 2013.
- [95] Wolfgang Gatterbauer, Paul Bohunsky, Marcus Herzog, Bernhard Krüpl, and Bernhard Pollak. Towards domain-independent information extraction from web tables. In *World Wide Web*, pages 71–80, 2007.
- [96] Thomas R Gruber. Toward principles for the design of ontologies used for knowledge sharing. *International journal of human-computer studies*, 43(5):907–928, 1995.

- [97] Tom Gruber, In Ling Liu Ontology, and M Tamer Özsu. Encyclopedia of database systems. *Ontology*, 2009.
- [98] Jianmei Guo, Edward Zulkoski, Rafael Olaechea, Derek Rayside, Krzysztof Czarnecki, Sven Apel, and Joanne M Atlee. Scaling exact multi-objective combinatorial optimization by parallelization. In *Automated software engineering*, pages 409–420, 2014.
- [99] Negar Hariri, Carlos Castro-Herrera, Mehdi Mirakhorli, Jane Cleland-Huang, and Bamshad Mobasher. Supporting domain analysis through mining and recommending features from online product listings. *Transactions on Software Engineering*, 39(12):1736–1752, 2013.
- [100] Evelyn Nicole Haslinger, Roberto E Lopez-Herrejon, and Alexander Egyed. Reverse engineering feature models from programs’ feature sets. In *Working Conference on Reverse Engineering*, pages 308–312, 2011.
- [101] Evelyn Nicole Haslinger, Roberto Erick Lopez-Herrejon, and Alexander Egyed. On extracting feature models from sets of valid feature combinations. In *Fundamental Approaches to Software Engineering*, pages 53–67. 2013.
- [102] Florian Heidenreich, Pablo Sánchez, Joao Santos, Steffen Zschaler, Mauricio Alférez, Joao Araujo, Lidia Fuentes, Uirá Kulesza, Ana Moreira, and Awais Rashid. Relating feature models to other models of a software product line. In *Transactions on aspect-oriented software development*, pages 69–114. 2010.
- [103] David G Hendry and Thomas RG Green. Creating, comprehending and explaining spreadsheets: a cognitive interpretation of what discretionary users think of the spreadsheet model. *International Journal of Human-Computer Studies*, 40(6):1033–1065, 1994.
- [104] Felienne Hermans, Martin Pinzger, and Arie van Deursen. Detecting and visualizing inter-worksheet smells in spreadsheets. In *International Conference on Software Engineering*, pages 441–451, 2012.
- [105] Felienne Hermans, Martin Pinzger, and Arie Van Deursen. *Domain-specific languages in practice: A user study on the success factors*. Springer, 2009.
- [106] Felienne Hermans, Martin Pinzger, and Arie van Deursen. Automatically extracting class diagrams from spreadsheets. In *ECOOP*, pages 52–75. 2010.
- [107] Felienne Hermans, Martin Pinzger, and Arie Van Deursen. Supporting professional spreadsheet users by generating leveled dataflow diagrams. In *International Conference on Software Engineering*, pages 451–460, 2011.
- [108] Marijn JH Heule, Matti Järvisalo, and Armin Biere. Efficient cnf simplification based on binary implication graphs. In *Theory and Applications of Satisfiability Testing*, pages 201–215. 2011.
- [109] A. Hubaux, M. Acher, T. T. Tun, P. Heymans, P. Collet, and P. Lahire. *Domain Engineering: Product Lines, Conceptual Models, and Languages*, chapter Separating Concerns in Feature Models: Retrospective and Multi-View Support. Springer, 2013.
- [110] Arnaud Hubaux, Thein Than Tun, and Patrick Heymans. Separation of concerns in feature diagram languages: A systematic survey. *ACM Computing Surveys*, 45(4):51, 2013.
- [111] Matthew Hurst. Layout and language: Challenges for table understanding on the web. In *International Workshop on Web Document Analysis*, pages 27–30, 2001.
- [112] Matthew Francis Hurst. The interpretation of tables in texts. 2000.
- [113] Javier Luis Cánovas Izquierdo and Jordi Cabot. Enabling the collaborative definition of dsmls. In *Advanced Information Systems Engineering*, pages 272–287, 2013.

- [114] Aleksandar Jakšić, Robert B France, Philippe Collet, and Sudipto Ghosh. Evaluating the usability of a visual feature modeling notation. In *International Conference on Software Language Engineering*, pages 122–140. Springer, 2014.
- [115] Mikoláš Janota, Victoria Kuzina, and Andrzej Wasowski. Model construction with external constraints: An interactive journey from semantics to syntax. In *Model Driven Engineering Languages and Systems*, pages 431–445. 2008.
- [116] Faizan Javed, Marjan Mernik, Jeff Gray, and Barrett R Bryant. Mars: A metamodel recovery system using grammar inference. *Information and Software Technology*, 50(9):948–968, 2008.
- [117] Kyo C Kang, Sholom G Cohen, James A Hess, William E Novak, and A Spencer Peterson. Feature-oriented domain analysis (foda) feasibility study. Technical report, DTIC Document, 1990.
- [118] Kyo C Kang, Jaejoon Lee, and Patrick Donohoe. Feature-oriented product line engineering. *IEEE software*, (4):58–65, 2002.
- [119] Gabor Karsai, Holger Krahn, Class Pinkernell, Bernhard Rumpe, Martin Schneider, and Steven Völkel. Design guidelines for domain specific languages. In Matti Rossi, Jonathan Sprinkle, Jeff Gray, and Juha-Pekka Tolvanen, editors, *OOPSLA Workshop on Domain-Specific Modeling*, pages 7–13, 2009.
- [120] Christian Kastner, Alexander Dreiling, and Klaus Ostermann. Variability mining: Consistent semi-automatic detection of product-line features. *Transactions on Software Engineering*, 40(1):67–82, 2014.
- [121] Steven Kelly and Risto Pohjonen. Worst practices for domain-specific modeling. *IEEE Software*, 26(4):22–29, 2009.
- [122] Charles W Krueger. Biglever software gears and the 3-tiered spl methodology. In *Object-oriented programming systems and applications companion*, pages 844–845, 2007.
- [123] Filippo Lanubile, Christof Ebert, Rafael Prikladnicki, and Aurora Vizcaíno. Collaboration tools for global software engineering. *IEEE software*, (2):52–55, 2010.
- [124] Jesús J López-Fernández, Jesús Sánchez Cuadrado, Esther Guerra, and Juan de Lara. Example-driven meta-model development. *Software & Systems Modeling*, pages 1–25, 2013.
- [125] Roberto E Lopez-Herrejon, Lukas Linsbauer, José A Galindo, José A Parejo, David Benavides, Sergio Segura, and Alexander Egyed. An assessment of search-based techniques for reverse engineering feature models. *Journal of Systems and Software*, 103:353–369, 2015.
- [126] Roberto Erick Lopez-Herrejon, José A Galindo, David Benavides, Sergio Segura, and Alexander Egyed. Reverse engineering feature models with evolutionary algorithms: An exploratory study. In *Search Based Software Engineering*, pages 168–182. 2012.
- [127] Daniel Lopresti and George Nagy. A tabular survey of automated table processing. In *Graphics Recognition Recent Advances*, pages 93–120. 1999.
- [128] James MacQueen et al. Some methods for classification and analysis of multivariate observations. In *Berkeley symposium on mathematical statistics and probability*, volume 1, pages 281–297, 1967.
- [129] Olena Medelyan, David Milne, Catherine Legg, and Ian H Witten. Mining meaning from wikipedia. *International Journal of Human-Computer Studies*, 67(9):716–754, 2009.
- [130] MediaWiki documentation on tables. <https://www.mediawiki.org/wiki/Help:Tables>.
- [131] Marcilio Mendonca, Moises Branco, and Donald Cowan. Splot: software product lines online tools. In *Object oriented programming systems languages and applications*, pages 761–762, 2009.

- [132] Marcilio Mendonca, Andrzej Wąsowski, and Krzysztof Czarnecki. Sat-based analysis of feature models is easy. In *Software Product Line Conference*, pages 231–240, 2009.
- [133] Andreas Metzger, Klaus Pohl, Patrick Heymans, Pierre-Yves Schobbens, and Germain Saval. Disambiguating the documentation of variability in software product lines: A separation of concerns, formalization and automated analysis. In *Requirements Engineering Conference*, pages 243–253, 2007.
- [134] George A Miller. Wordnet: a lexical database for english. *Communications of the ACM*, 38(11):39–41, 1995.
- [135] David Milne. Computing semantic relatedness using wikipedia link structure. In *New zealand computer science research student conference*, 2007.
- [136] David Milne and Ian H Witten. An open-source toolkit for mining wikipedia. *Artificial Intelligence*, 194:222–239, 2013.
- [137] Pierre-Alain Muller, Frédéric Fondement, Benoit Baudry, and Benoît Combemale. Modeling modeling modeling. *Software & Systems Modeling*, 11(3):347–359, 2012.
- [138] Alexandr Murashkin, Michał Antkiewicz, Derek Rayside, and Krzysztof Czarnecki. Visualization and exploration of optimal variants in product line engineering. In *Software Product Line Conference*, pages 111–115, 2013.
- [139] Sarah Nadi, Thorsten Berger, Christian Kästner, and Krzysztof Czarnecki. Mining configuration constraints: Static analyses and empirical results. In *International Conference on Software Engineering*, pages 140–151, 2014.
- [140] Sarah Nadi and Ric Holt. The linux kernel: A case study of build system variability. *Journal of Software: Evolution and Process*, 26(8):730–746, 2014.
- [141] Nan Niu and Steve Easterbrook. Concept analysis for product line requirements. In *Aspect-oriented software development*, pages 137–148, 2009.
- [142] Open Knowledge Foundation. <https://okfn.org/opendata/>.
- [143] Raymond R Panko. Thinking is bad: Implications of human error research for spreadsheet research and practice. *arXiv preprint arXiv:0801.3114*, 2008.
- [144] Andreas Pleuss and Goetz Botterweck. Visualization of variability and configuration options. *International Journal on Software Tools for Technology Transfer*, 14(5):497–510, 2012.
- [145] Klaus Pohl, Günter Böckle, and Frank J van der Linden. *Software product line engineering: foundations, principles and techniques*. Springer Science & Business Media, 2005.
- [146] Randolph Pohl, Vanessa Stricker, and Klaus Pohl. Measuring the structural complexity of feature models. In *Automated Software Engineering*, pages 454–464, 2013.
- [147] Richard Pohl, Kim Lauenroth, and Klaus Pohl. A performance comparison of contemporary algorithmic approaches for automated analysis operations on feature models. In *Automated Software Engineering*, pages 313–322, 2011.
- [148] pure::variants. http://www.pure-systems.com/pure_variants.49.0.html.
- [149] Clément Quinton, Andreas Pleuss, Daniel Le Berre, Laurence Duchien, and Goetz Botterweck. Consistency checking for the evolution of cardinality-based feature models. In *Proceedings of the 18th International Software Product Line Conference-Volume 1*, pages 122–131. ACM, 2014.
- [150] Clément Quinton, Daniel Romero, and Laurence Duchien. Cardinality-based feature models with constraints: a pragmatic approach. In *Proceedings of the 17th International Software Product Line Conference*, pages 162–166. ACM, 2013.

- [151] Ariel Rabkin and Randy Katz. Static extraction of program configuration options. In *International Conference on Software Engineering*, pages 131–140, 2011.
- [152] Alberto Rodrigues da Silva. Model-driven engineering. *Computer Languages, Systems and Structures*, 43(C):139–155, 2015.
- [153] J Rubin and M Chechik. Domain engineering: Product lines, conceptual models, and languages, chap. a survey of feature location techniques, 2013.
- [154] Julia Rubin and Marsha Chechik. Locating distinguishing features using diff sets. In *Automated Software Engineering*, pages 242–245, 2012.
- [155] Uwe Ryssel, Joern Ploennigs, and Klaus Kabitzsch. Extraction of feature models from formal contexts. In *Software Product Line Conference*, page 4, 2011.
- [156] Nicolas Sannier, Mathieu Acher, and Benoit Baudry. From comparison matrix to variability model: The wikipedia case study. In *Automated Software Engineering*, pages 580–585, 2013.
- [157] Abdel Salam Sayyad, Tim Menzies, and Hany Ammar. On the value of user preferences in search-based software engineering: a case study in software product lines. In *International Conference on Software engineering*, pages 492–501, 2013.
- [158] Klaus Schmid, Rick Rabiser, and Paul Grünbacher. A comparison of decision modeling approaches in product lines. In *Workshop on Variability Modeling of Software-Intensive Systems*, pages 119–126, 2011.
- [159] Douglas C Schmidt. Model-driven engineering. *IEEE computer society*, 39(2):25, 2006.
- [160] Pierre-Yves Schobbens, Patrick Heymans, Jean-Christophe Trigaux, and Yves Bontemps. Generic semantics of feature diagrams. *Computer Networks*, 51(2):456–479, 2007.
- [161] Christoph Seidl, Ina Schaefer, and Uwe Assmann. Capturing variability in space and time with hyper feature models. In *Workshop on Variability Modelling of Software-Intensive Systems*, page 6, 2014.
- [162] Steven She. *Feature Model Synthesis*. PhD thesis, University of Waterloo, 2013.
- [163] Steven She, Krzysztof Czarnecki, and Andrzej Wąsowski. Usage scenarios for feature model synthesis. In *VARIability for You Workshop: Variability Modeling Made Useful for Everyone*, pages 15–20, 2012.
- [164] Steven She, Rafael Lotufo, Thorsten Berger, Andrzej Wasowski, and Krzysztof Czarnecki. The variability model of the linux kernel. *VaMoS*, 10:45–51, 2010.
- [165] Steven She, Rafael Lotufo, Thorsten Berger, Andrzej Wąsowski, and Krzysztof Czarnecki. Reverse engineering feature models. In *International Conference on Software Engineering*, pages 461–470, 2011.
- [166] Steven She, Uwe Ryssel, Nele Andersen, Andrzej Wąsowski, and Krzysztof Czarnecki. Efficient synthesis of feature models. *Information and Software Technology*, 56(9):1122–1143, 2014.
- [167] Alexey O Shigarov. Table understanding using a rule engine. *Expert Systems with Applications*, 42(2):929–937, 2015.
- [168] Temple F Smith and Michael S Waterman. Identification of common molecular subsequences. *Journal of molecular biology*, 147(1):195–197, 1981.
- [169] SPLOT: Software Product Line Online Tools. <http://www.splot-research.org/>.
- [170] Robert Endre Tarjan. Finding optimum branchings. *Networks*, 7(1):25–35, 1977.

- [171] Sahil Thaker, Don Batory, David Kitchin, and William Cook. Safe composition of product lines. In *Generative programming and component engineering*, pages 95–104, 2007.
- [172] Thomas Thüm, Sven Apel, Christian Kästner, Ina Schaefer, and Gunter Saake. A classification and survey of analysis strategies for software product lines. *ACM Computing Surveys*, 47(1):6, 2014.
- [173] Thomas Thüm, Don Batory, and Christian Kästner. Reasoning about edits to feature models. In *International Conference on Software Engineering*, pages 254–264, 2009.
- [174] Thomas Thüm, Christian Kästner, Fabian Benduhn, Jens Meinicke, Gunter Saake, and Thomas Leich. Featureide: An extensible framework for feature-oriented software development. *Science of Computer Programming*, 79:70–85, 2014.
- [175] Yuri A Tijerino, David W Embley, Deryle W Lonsdale, Yihong Ding, and George Nagy. Towards ontology generation from tables. *World Wide Web*, 8(3):261–285, 2005.
- [176] Etsuji Tomita, Akira Tanaka, and Haruhisa Takahashi. The worst-case time complexity for generating all maximal cliques and computational experiments. *Theoretical Computer Science*, 363(1):28–42, 2006.
- [177] Edoardo Vacchi, Walter Cazzola, Benoit Combemale, and Mathieu Acher. Automating variability model inference for component-based language implementations. In *Software Product Line Conference*, pages 167–176, 2014.
- [178] Marco Tulio Valente, Virgilio Borges, and Leonardo Passos. A semi-automatic approach for extracting software product lines. *Transactions on Software Engineering*, 38(4):737–754, 2012.
- [179] Markus Voelter, Sebastian Benz, Christian Dietrich, Birgit Engelmann, Mats Helander, Lennart C. L. Kats, Eelco Visser, and Guido Wachsmuth. *DSL Engineering - Designing, Implementing and Using Domain-Specific Languages*. dslbook.org, 2013.
- [180] Markus Voelter, Sebastian Benz, Christian Dietrich, Birgit Engelmann, Mats Helander, Lennart CL Kats, Eelco Visser, and Guido Wachsmuth. *DSL engineering: Designing, implementing and using domain-specific languages*. dslbook.org, 2013.
- [181] Alexander von Rhein, Alexander Grebhahn, Sven Apel, Norbert Siegmund, Dirk Beyer, and Thorsten Berger. Presence-condition simplification in highly configurable systems. In *International Conference Software Engineering*, 2015.
- [182] Robert A Wagner and Michael J Fischer. The string-to-string correction problem. *Journal of the ACM*, 21(1):168–173, 1974.
- [183] Jingjing Wang, Haixun Wang, Zhongyuan Wang, and Kenny Q Zhu. Understanding tables on the web. In *Conceptual Modeling*, pages 141–155. 2012.
- [184] Xinxin Wang and Derick Wood. *Tabular abstraction, editing, and formatting*. Citeseer, 1996.
- [185] Yalin Wang and Jianying Hu. A machine learning based approach for table detection on the web. In *World Wide Web*, pages 242–250, 2002.
- [186] David M. Weiss and Chi Tau Robert Lai. *Software Product-line Engineering: A Family-based Software Development Process*. Addison-Wesley Longman Publishing Co., Inc., Boston, MA, USA, 1999.
- [187] Nathan Weston, Ruzanna Chitchyan, and Awais Rashid. A framework for constructing semantically composable feature models from natural language requirements. In *Software Product Line Conference*, pages 211–220, 2009.
- [188] Wikipedia documentation on tools to ease the work of contributors. <http://en.wikipedia.org/wiki/Wikipedia:Tools>.

- [189] Zhibiao Wu and Martha Palmer. Verbs semantics and lexical selection. In *Annual meeting on Association for Computational Linguistics*, pages 133–138, 1994.
- [190] Ora Wulf-Hadash and Iris Reinhartz-Berger. Cross product line analysis. In *Workshop on Variability Modelling of Software-Intensive Systems*, 2013.
- [191] Li Yi, Wei Zhang, Haiyan Zhao, Zhi Jin, and Hong Mei. Mining binary constraints in the construction of feature models. In *Requirements Engineering Conference*, pages 141–150, 2012.
- [192] R Zanibbi, D Blostein, and JR Cordy. A survey of table recognition: Models, observations, transformations, and inferences. *International Journal of Document Analysis and Recognition*, 7:1–16, 2003.

Bref. J'ai fait une thèse.