



HAL
open science

Improved False Causal Loop Detection in Polychronous Specification of Embedded Software

Bijoy Anthony Jose, Abdoulaye Gamatié, Matthew Kracht, Sandeep Kumar Shukla

► **To cite this version:**

Bijoy Anthony Jose, Abdoulaye Gamatié, Matthew Kracht, Sandeep Kumar Shukla. Improved False Causal Loop Detection in Polychronous Specification of Embedded Software. [Research Report] 2011, pp.28. inria-00637582

HAL Id: inria-00637582

<https://inria.hal.science/inria-00637582>

Submitted on 2 Nov 2011

HAL is a multi-disciplinary open access archive for the deposit and dissemination of scientific research documents, whether they are published or not. The documents may come from teaching and research institutions in France or abroad, or from public or private research centers.

L'archive ouverte pluridisciplinaire **HAL**, est destinée au dépôt et à la diffusion de documents scientifiques de niveau recherche, publiés ou non, émanant des établissements d'enseignement et de recherche français ou étrangers, des laboratoires publics ou privés.



F E R M A T

Formal Engineering Research using Methods, Abstractions and Transformations

Technical Report No: 2011-08

Abstract –

As opposed to single clocked synchronous programming paradigms, polychronous formalism allows specification of concurrent data flow computation on signals such that various data flows can evolve asynchronous with respect to each other. Explicit constraints and constraints implied by the syntactic structures impart certain intrinsic properties to models specified polychronously. One of the major steps in designing a synthesis engine for polychronous specifications is the characterization of specified models into categories such as inherently sequential or inherently multi-threaded. In this paper, we are concerned with sequentially implementable polychronous specification where computation is divided into a totally ordered sequence of logical instants. Data flow computation within an instant happens based on the implied data flow order. This order or data dependency often varies from one instant to another. Thus determining if there is an instant at which the data flow order forms a causal cycle is an important problem. In the current polychronous compilers, such as SIGNAL compiler and EmCodeSyn, this is solved without due effort, by rejecting any program which has a buffer-free structural cycle. However, a clocked dependency graph can be used to construct logical constraints representing the instants with a possible causal loop. The satisfiability of such constraints would imply that such a loop is realizable and hence the specification has a possible deadlock. The reachability of this instant with a given set of initial conditions would verify if the program should be rejected. In the past, the work on such constraints and their satisfiability has not been implemented even though for pure Boolean signals and clocks this could have been done using a satisfiability solver. With the advent to SAT modulo theory (SMT) solvers, this can now be extended to a more general class of specifications. Moreover, model checking on an abstraction of the specification can provide more information about the reachability of instants at which cyclic data dependency is realized. This paper presents an improved polychronous synthesis tool accepting a much larger class of specifications than could be done before. In our experimental results, we demonstrate the capabilities of our causality analysis methods and show that our synthesis tool performs better than previous strategies, including our own past work.

Improved False Causal Loop Detection in Polychronous Specification of Embedded Software

Bijoy A. Jose, Aboulaye Gamatie, Matthew Kracht and
Sandeep K. Shukla
{bijoy,mwkracht,shukla}@vt.edu
abdoulaye.gamatie@lifl.fr

I. INTRODUCTION

Instantaneous or causal loops, i.e., cyclic data dependency within an instant, have been a problem in all languages in the synchronous programming paradigm. Various solutions to the problem of detecting causal loops and non-realizable apparent causal loops, referred to as *false causal loop*, have appeared in the literature of Esterel [1], Lustre [2], SIGNAL [3], and hardware description languages. In general, the problem is undecidable because determining if a loop is realizable may be dependent on arbitrary data types, and arbitrary functions on such data. As a result, approximations have been proposed. To err on the side of the caution, due to false positives, a lot of correct programs are rejected by compilers. In the early days of synchronous programming, syntactic checks were used, leading to too many false causal loops. Since then, semantic analysis have been incorporated in many of the compilers. Unfortunately, in the polychronous programming literature, not a lot of attention has been paid to this problem beyond 1) syntactic detection rejecting all buffer-free loops as implemented in the Polychrony compiler [4] and 2) causal loop detection using nullity check of clock intersection in SIGNAL programs [5]. With the advent of SAT Modulo theory checkers, these approximations dealing with Boolean data types can be vastly improved. Also, the causal loop detection techniques can be extended to analyze nuances of polychronous calculus and thus detect falsity of apparent causal loops. In this paper, we revisit the problem of false causal loops in Polychronous specifications, and show how we solve this problem in our polychronous framework *MRICDF* [6].

Multi-Rate Instantaneous Channel connected Data Flow language (MRICDF) is a visual polychronous formalism, where actors communicate with each other through instantaneous channels while imposing restrictions on event occurrences on ports of actors [7]. The possibly infinite stream of events on a signal is called as *epoch* in MRICDF or *clock* in SIGNAL [8]. An epoch analysis step was proposed where a top-down approach is taken to construct a *follower set*. It is an ordered set of signals arranged according to their epochs in descending order. It is equivalent to a clock tree constructed bottom-up using *clock calculus* technique for SIGNAL programs. Epoch analysis is performed at the Boolean domain, where each signal is represented as a Boolean variable with true/false denoting the presence/absence of an event respectively. Beyond causality analysis, epoch analysis infers a signal with the largest set of events called the *master trigger*. This is equivalent to the root clock signal in SIGNAL terminology, which will be found

as the root node in the clock tree. The SIGNAL compiler Polychrony [9] considers an acyclic polychronous specification as sequentially implementable, if a hierarchic clock tree with root clock is found using clock calculus technique [10]. For EmCodeSyn [11], an acyclic MRICDF specification must have a master trigger and a follower set for sequential software synthesis [12]. The causality analysis techniques implemented by both these tools are limited by the intermediate representation formats used for software synthesis. We demonstrate their vulnerabilities with a few motivating examples in the next subsection. The improvements proposed in this work are not limited to our EmCodeSyn framework, and are applicable to other polychronous synthesis tools.

A. Motivational examples and problem statement

We introduce the problems addressed in this paper by giving polychronous specifications containing possible causal loops.

Example 1 (Causal loop detection): A polychronous MRICDF network *Spec1* with its equivalent SIGNAL program are shown in Figure 1. There are two *Merge* MRICDF actors M_1 and M_2 which merge input streams with a higher priority given to first input port on occurrences of simultaneous events.

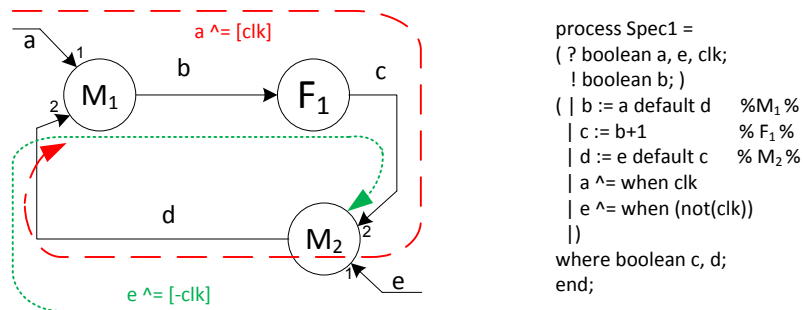

Fig. 1. *Spec1*: causal loop specification in MRICDF (left) and SIGNAL (right)

Merge actors (here M_1 and M_2) give priority to port 1 over port 2. An external signal clk decides the flow of data in the specification. When clk is present and true (shown as $[clk]$), there are events on a connected to M_1 and not on e . Consequently, M_1 ignores inputs on port 2, which means the data does not flow through the entire loop as shown by the red dashed lines. When clk is present and false (shown as $[-clk]$), input signals are present on signal e

connected to M_2 and not on a . Now, the flow of data is shown by dotted green lines. In both cases, the edges of the data flow network loop, i.e., signals b , c and d are active. But, there is no causal loop $b \rightarrow c \rightarrow d \rightarrow b$. Also, there is no possible input for the specification which can lead to a causal loop.

Polychrony compiler and EmCodeSyn cannot synthesize sequential code for the program `Spec1` in Figure 1. A dependency cycle is reported between variables b , c and d . But, we learned how the polychronous nature of the specification ensured a data dependent loop does not arise. The clock tree representation of Polychrony and the Boolean theory representation of EmCodeSyn are insufficient to determine implementability of such specifications.

Example 2 (Causal loop formed by clock and data constraints): A polychronous MRICDF network `Spec2` with its equivalent SIGNAL program are shown in Figure 2. There is a Merge actor M_1 , a Sampler actor S_1 and a Function actor F_1 in the MRICDF network. The Sampler actor S_1 passes the value of any event at `ain` onto a when the Boolean input trigger has a true valued event. Function actor F_1 computes the sum of b and d . Two possible constraints ($C1, C2$) are shown with $C1$ included as a part of SIGNAL code.

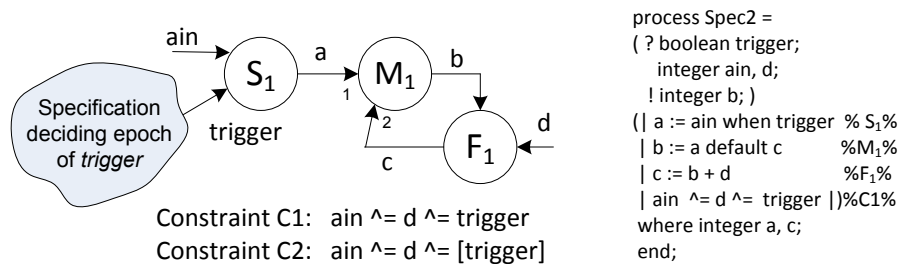

Fig. 2. `Spec2`: Evaluating causal loop conditions with clock and data constraints

In the SIGNAL program `Spec2`, due to the clock constraint $C1$, a continuous stream of events is guaranteed at signals `ain`, `d` and `trigger`. When `trigger` signal is present with a false value, there is no event at a . Here, a causal loop ($b \rightarrow c \rightarrow b$) may be formed. In order to avoid this situation, clock constraint $C2$ can be applied guaranteeing always true values at `trigger` (represented as `[trigger]`). Since Merge actor has a higher priority for port 1, events at port 2 are ignored and thus a causal loop is avoided.

Polychrony and EmCodeSyn will reject `Spec2` with constraint $C1$, accept `Spec2` with constraint $C2$ and rightly so. If `trigger` is not an external input, rather a data computation

D1 requiring Integer arithmetic (say `trigger := false` when `(ain > 5 and ain < 2)` default `true`), both tools will reject the specification. Here, `trigger` can be `false` only when `ain` is greater than 5 and less than 2, which is impossible. But the intermediate structures of Polychrony and EmCodeSyn are not powerful enough to capture and evaluate these conditions. In fact, if code generation is forced on Polychrony, a causal loop ($b \rightarrow c \rightarrow b$) is warned. In summary, there is a need to move onto more expressive and powerful structures which expand the set of implementable polychronous programs using a software tool.

In a recent work, verification tools were shown to be efficient in software synthesis for generic computing algorithms [13]. Program guards are evaluated as verification problems to determine program execution. One popular verification tool, the SMT solver [14], is capable of evaluating theories of various data structures as motivated by Example 2. Recent developments in SAT and SMT solvers [15] have made their use in synthesis practical. Improving the synthesis time for Boolean theory-based synthesis is the second problem we address in this paper. We use a prime implicate generator [16] for master trigger identification. This generator has long synthesis time, making our tool impractical for larger designs. Enhancements in synthesis time have been achieved by optimizing MRICDF networks, thereby reducing the number of Boolean equations to be analyzed [17]. Other options include faster algorithms for prime implicate generation or pursuit of alternatives for prime implicate generator.

B. Our solution

In general, our contributions aim to enhance sequential software synthesis from polychronous specifications. For this purpose, we propose an extension to our recent work on using SMT solvers for sequential software synthesis [18]. In this work, we show how to perform time-efficient causality analysis by adopting a mix of verification tools for each causal loop problem. We also show that SMT solvers can be used to replace a time consuming prime implicate based implementation of our Boolean theory approach to synthesis. The techniques employed albeit related to polychronous formalisms, are applicable in other embedded software synthesis tools which follow synchronous MoCs.

In particular, we distinguish the following two issues:

- 1) *Expressive causality analysis for polychronous specification employing verification tools.*
Data domain constraints and non-realizability of a clock constraint at which a data depen-

dence loop is formed cannot be properly utilized in the absence of expressive theory of data domains, arithmetic, and propositional satisfiability. In existing tools, the absence of these techniques leads to overly pessimistic compilation, rejecting many polychronous specifications with non-realizable causal loops. A new SMT based approach is used to check actual data dependencies in causal loops. We distinguish different types of causal loops in polychronous specification and a heuristic tailored for faster detection is implemented which uses specific verification techniques.

- 2) *Shortening the code synthesis time.* The Boolean theory approach of testing for root clock (or master trigger) is implemented by interfacing an SMT solver. The synthesis time is shown to be significantly better than a direct prime implicate computation technique to find root clock.

a) Outline: This paper is organized as follows. Section II reviews the existing work on software synthesis from polychronous specification and the different causal loop analysis techniques related to synchronous MoC. In Section III, we provide the background information on polychronous formalism and explain our Boolean theory based synthesis technique. Section IV deals with the causality analysis improvements proposed and experiments conducted with EmCodeSyn. Section V explains how software synthesis is performed using SMT solvers. Experimental results are provided in respective sections to analyze the efficiency of each contribution. The paper is concluded in Section VI.

II. RELATED WORK ON SOFTWARE SYNTHESIS FROM SYNCHRONOUS SPECIFICATION

We cover the existing work on software synthesis from polychronous specification and the different causal loop analysis techniques related to synchronous MoC. At the heart of synchronous MoC is the *synchrony hypothesis* [19] that assumes instantaneous computations and communications between actors. In other words, the time to compute and communicate is negligible compared to the time between two adjacent events on a signal.

Different programming languages exist which follow the synchronous model of computation, such as Esterel, Lustre and SIGNAL. Esterel is an imperative synchronous programming language where computations are performed as reaction steps [20], [21]. Testing for presence of an event on a signal is allowed and accordingly specific computations are selected for execution. The software synthesis tools that accept concurrent Esterel specifications such as

Esterel Studio [22] and Columbia Esterel Compiler [23] can generate optimized RTL or C code from the different possible orders of execution. Quartz [24] is a variation of Esterel language which has its own synthesis and verification environment called Averest [25]. Lustre on the other hand is a declarative synchronous language where specifications are expressed in terms of data flow equations [26]. In Lustre programs, every signal clock is analyzed in reference to a single simulation clock. Here, multi-rate signals have to be expressed as undersamplings of the simulation clock. A software synthesis tool based on Lustre is the SCADE suite [27], which has been used in the avionics field. Also available is a higher order functional variant of Lustre known as Lucid Synchrone [28].

A recent work [10] has summarized sequential synthesis condition of SIGNAL programs as follows: a compilable and hierarchic SIGNAL program is *endochronous*. In other words, a sequentially implementable SIGNAL specification would not contain causal loops and its clock tree would be hierarchic with a root clock. One of the goals of our work is to improve causal loop detection for SIGNAL/MRICDF formalism. There has been a significant amount of work in this direction for hardware circuits and synchronous systems. An early work on the analysis of cycles in combinatorial circuits uses ternary symbolic simulation method [29]. This work was extended later to sequential circuits and to Esterel language. ‘Constructivity’ [30] was proposed, which considers a circuit to be acyclic if and only if for every external input a unique value can be determined for each internal and output signal. A sequential circuit is constructive if the combinational part is constructive for given input values and the latch outputs are restricted to reachable states [31]. A heuristic was proposed where ternary symbolic simulation is performed to see if the set of unstable states is empty. If so, the circuit is declared constructive. Otherwise, a reachability analysis is done to see if any of the unstable states is reachable from a sequence of given inputs. Our analysis of false causal loops is similar to this work, since we check for a possible input sequence to activate the causal loop condition.

Checking constructivity as a Satisfiability problem was proposed in [32]. In their formal verification system, a set of internal signals are identified, which would eliminate all syntactic cycles. A constructivity-SAT formula for a cycle is defined to perform reachability analysis. In addition, an error path from initial state to a state where the cycle is true is determined. Thus the cycle analysis has been extended to finite non-Boolean types. In Esterel, instantaneous termination due to incorrect programs or schizophrenic programs was analyzed in [33]. A

program is declared *instantaneous* iff the execution completes in a single reaction. The analysis of causal loops using using SAT techniques was suggested, but was not experimented with. Some provable correct Esterel programs were noted to be rejected due to incomplete causality analysis. Other prominent works on causality analysis provide optimizations for causality elimination [34] and applying standard logic synthesis techniques [35]. A common thread in these works is isolation of specific properties useful for causality analysis in the respective synchronous languages or the use of verification techniques such as model checking [36], [37].

In SIGNAL, a recent work [38] has experimented dead code detection based on computation of intervals for values of signals. Parts of a program can be rejected if the expected values did not fall in the computed interval. Another work [39] includes translation of polychronous specifications into synchronous ones for causality analysis. The work aimed at embedding a polychronous specification in SIGNAL/MRICDF form into a synchronous Quartz model to utilize the capabilities of Averest environment. The current work is an extension of [18], where causality analysis and synthesis using SMT solvers was originally proposed. These were based on our Boolean theory based alternative to clock calculus for performing software synthesis.

III. SOFTWARE SYNTHESIS FROM POLYCHRONOUS FORMALISM

For a better understanding of our work, we provide some preliminaries on synchronous structures and a background into our visual polychronous formalism, synthesis technique, and code generation tool.

A. Preliminaries on synchronous structure

We present first some basic definitions about the synchronous model of computation using synchronous structures as defined in [40].

Definition 1 (Events, Signals): An event is an occurrence of a value. A signal is a totally ordered set of events.

For a signal x , an event on x is denoted by e_x and the set of all events on x is denoted by $E(x)$.

The set of all events in a specification is denoted by Ξ .

Definition 2 (Synchronous structure): The pair (Ξ, \ll) is a synchronous structure if and only if Ξ is a non-empty set of events and \ll is a preorder on Ξ such that $\forall x \in \Xi \cdot \{y \in \Xi \mid y \leq x\}$ is finite, where the following relations are defined:

- (equivalence) $x \sim y \Leftrightarrow_{def} x \ll y \wedge y \ll x$
- (precedence) $x < y \Leftrightarrow_{def} x \ll y \wedge x \not\sim y$
- (partial order) $x \leq y \Leftrightarrow_{def} x < y \wedge x = y$

Definition 3 (Instant): If the set of all events Ξ is partitioned using the equivalence relation \sim , equivalence classes containing events that are synchronous with each other are formed. Each of these equivalence classes is called an instant, i.e., $\Upsilon = \Xi / \sim$.

Any event e_x on a signal x belongs to an instant of a synchronous structure, say $S \in \Upsilon$. We denote it as $e_x \triangleright S$.

Definition 4 (Epoch): The epoch of a signal is a possibly infinite set of instants where that signal has events.

For a signal x , $I(x)$ or \hat{x} are used to denote its epoch. An epoch is also known as *clock* of a signal in SIGNAL terminology. The synchronous relations defined on events in signals are extended as relations between epochs of signals.

Definition 5 (Synchronous signals): If two signals have the same epoch, they are said to be synchronous. For two synchronous signals x and y , $I(x) = I(y)$. Both signals have events belonging to the same instant S , where $S \in \Upsilon$. $\forall S \in I(x) \Leftrightarrow S \in I(y)$.

In SIGNAL, synchronous nature of two signals x, y can be denoted by $x \wedge = y$.

B. MRICDF formalism and the Boolean theory based sequential synthesis strategy

The four basic actors of MRICDF formalism are `Function`, `Buffer`, `Sampler` and `Merge`. They are derived from SIGNAL primitives and have the same epoch constraints as mentioned in Figure 3. A few sample traces demonstrating each of their operation is shown in a table near each actor. The symbol \perp denotes absence of an event in a signal. The `Function` actor imposes an epoch equality for input-output signals. It performs user-specified computations within an instant. The `Buffer` actor acts as a single input-output storage, imposing epoch equality for input and output signals. On occurrence of an input event, its value is stored and the stored value from previous instant is given as output. `Sampler` actor performs a downsampling operation of its first input epoch. On an occurrence of *true* value on its Boolean second input port (represented as $[b]$), the event at first input is sent to the output. The `Merge` actor combines input streams from two input ports with a higher priority for the first input port. It performs an upsampling operation on the epochs of its inputs.

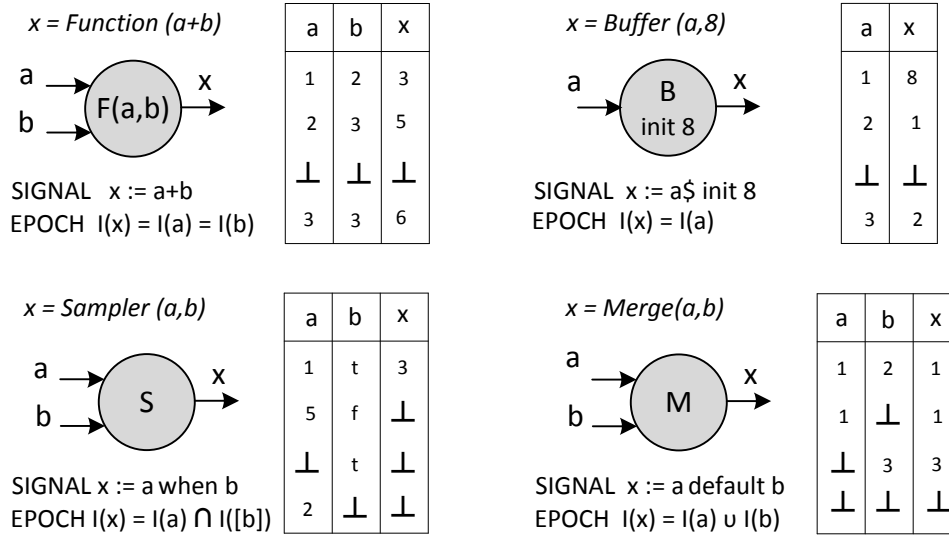

Fig. 3. MRICDF actor primitives

MRICDF Actor	Epoch relation	Boolean Equations
Function $F(2, 1)$	$I(x) = I(a) = I(b)$	$b_x = b_a, b_x = b_b$
Buffer B	$I(x) = I(a)$	$b_x = b_a$
Sampler S	$I(x) = I(a) \cap I([b])$	$b_x = b_a \wedge b_{[b]}, b_b = b_{[b]} \vee b_{[-b]}, b_{[b]} \wedge b_{[-b]} = false$
Merge M	$I(x) = I(a) \cup I(b)$	$b_x = b_a \vee b_b$

TABLE I

MRICDF ACTOR PRIMITIVES AND THEIR EPOCH CONSTRAINTS

The epoch relations of each MRICDF actor can be represented in Boolean domain as shown in Table I. Here, the presence and absence of any signal x at any arbitrary instant is represented by *true* and *false* values respectively on b_x . The instants where a signal of Boolean type, say x , is present having a *true* value is denoted by $b_{[x]}$ and instants where x is present having a *false* value is denoted by $b_{[-x]}$. So, for such a signal x , we know $b_x = b_{[x]} \vee b_{[-x]}$ and $b_{[x]} \wedge b_{[-x]} = false$. Once a given MRICDF specification is translated to Boolean domain according to Table I, the root clock, or in our terminology the *master trigger*, has to be found. It is the signal which is present at every instant of the MRICDF network, and will be used as a reference to start computation at every instant.

Definition 6 (Master Trigger): Let M be an MRICDF network. Let t be a signal with $E(t)$

as its set of events and Υ the set of all instants of the MRICDF network. For each $S \in \Upsilon$, if there exists an event $e_t \triangleright S$, then t is the master trigger for M .

We have proposed a test for detecting the existence of a master trigger signal working in the Boolean domain. This involves checking for the presence of any other signal when a master trigger candidate signal is absent. We remove those instants where no signal is present by adding a Boolean equation stating that the disjunction of all signal Boolean variables is *true*. This avoids the trivial solution to the system of Boolean equations (all Boolean variables are *false*).

The system of Boolean equations defines a theory which has all the satisfying assignments for the system. A disjunctive clause belonging to the theory is an implicate of the theory. If the disjunctive clause is not part of any other disjunctive clause, it is a prime implicate of the theory. If the prime implicate clause is a single positive Boolean literal b_t , we know that the b_t has to be *true* for any arbitrary instant. This represents the presence of the signal t in any arbitrary instant of the MRICDF network, which is the definition of the master trigger signal. Thus, testing for a prime implicate which is a single positive Boolean literal, is the same as testing for master trigger signal in an MRICDF network.

Theorem 1 (Test for Master Trigger signal): A signal x in an MRICDF network M is a master trigger, if and only if the corresponding Boolean variable b_x in the system of Boolean equations B_M has the property that if b_x is false, every other variable is false.

The proofs for master trigger test is available in [7]. If an MRICDF network has a master trigger (or multiple master trigger signals with same epoch), the next step is to identify a deterministic order of execution. This would involve identifying the signals in the order of descending epoch and a means to compute them from previously identified signals. If the master trigger Boolean variable b_x is set to *true*, a simplified system of equations representing the instants of the remaining signals is obtained. Here, a prime implicate clause may be found which represents all instants of the simplified MRICDF network. It might consist of multiple positive literals (say $(b_y + b_z)$), signifying that either y or z have events in all instants of the simplified MRICDF network. Now, b_y and b_z are set to *true* to get a simplified system of equations, and prime implicate steps are repeated. During this process, each prime implicate result is identifying signals have a lower epoch than those found from the previous run. Each prime implicate result provides signals that are elements of the *follower set*, if they are computable from already known signals in the follower set.

Eventually a complete follower set will be found for a synthesizable program which is a set of elements containing all the signals in the system. This is identical to building a clock hierarchy where the nodes are signals found as prime implicants and the edges are relations between them with already computed nodes. Together, the causal loop detection, master trigger identification and the follower set form our MRICDF synthesis condition. More details on follower set and synthesis conditions can be found in [12].

C. EmCodeSyn project and the use of verification tools for synthesis

EmCodeSyn is a visual framework for capturing polychronous specifications as MRICDF networks and generating sequential C code [11]. The visual interface and design methodology of EmCodeSyn is shown in Figure 4. The captured MRICDF network is stored in a Network Information File (NIF) file which can also be reused once stored in a library. In the Epoch Analysis step, the NIF of a design is put through causality analysis to find causal loops. If the network passes this step, Boolean equations are produced in Conjunctive Normal Form (CNF). An external prime implicate generator computes the prime implicants of the Boolean system formed from MRICDF network and a single positive literal is identified as the master trigger signal. If there is no master trigger signal, exogenous information in the form of epoch constraints have to be provided to construct a master trigger signal. Later, a follower set is built after an iterative prime implicate generation process. Once the follower set is complete, the MRICDF network is declared as sequentially implementable by EmCodeSyn. Now code generation takes place, where three C files represent the computation in the order of execution prescribed by the follower set. The dashed boxes represent the extensions we propose to the EmCodeSyn methodology and their details are explained later in the paper.

Identifying every element of the follower set involves an iteration of the external prime implicate generator. Each run consists of computing all possible prime implicants (PI) since the PI generator cannot identify a master trigger signal or clause. This results in high synthesis time. One optimization was actor elimination technique (AET) which decreased the number Boolean equations fed to the prime implicate generator, thus reducing synthesis time [17].

The synthesis time was considerably reduced by better PI generators and our optimization technique [12]. Nevertheless, for larger examples, finding all possible prime implicants leads to a long synthesis time. An intelligent master trigger detection process was required instead

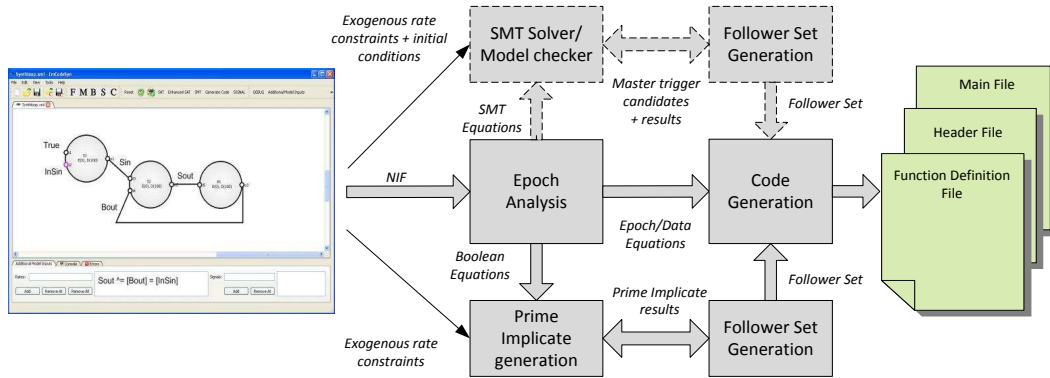

Fig. 4. Visual Interface and design methodology of EmCodeSyn

of a non judicious all-at-once PI generation. Once a master trigger is identified, the process had to terminate and intelligent choices had to be made on which candidate to test first. All of this pointed to exploring alternatives to the black box external prime implicate generator. SMT solvers were found to be a likely option in [18]. Hence, posing the test for master trigger as a satisfiability problem and evaluating the performance of the two master trigger detection strategies was performed in this work.

IV. CAUSAL LOOP DETECTION ON POLYCHRONOUS SPECIFICATIONS

Among the tools adopting a polychronous MoC, Polychrony and EmCodeSyn analyze clock (or epoch) relations in specifications to determine if a causal loop exists. We differentiate the kinds of causal loops in polychronous specifications and explain how we improve the existing loop detection techniques.

Definition 7 (Topological Loop): A polychronous specification is said to contain a topological loop provided the specification consists of a set of actors (i) a_1, a_2, \dots, a_n , such that an output port of a_n is connected to an input port of a_1 ; and (ii) for all actors $a_1, a_2, \dots, a_{n-1}, \forall i \in \{1..(n-1)\}$, an output port of the a_i^{th} actor is connected to an input port of the a_{i+1}^{th} actor.

A topological loop containing a buffer actor does not propagate data instantaneously. So, a buffered loop is not to be rejected.

Definition 8 (Buffered Loop): A topological loop where at least one of the actors in the loop is a storage element (*Buffer* actor) is called a buffered loop.

If a software synthesis tool is able to locate a buffer free topological loop, epoch constraints need to be evaluated to know if there exists an instant for the network where a cyclic data dependency happens. In Polychrony, causality analysis step checks for buffer-free loops where the signal clocks in the loop are active. In other words, SIGNAL programs are rejected if there exists a logical instant where clocks of signals in a buffer-free topological loop of a program are active.

Definition 9 (Apparent Causal Loop): Consider a polychronous specification with a topological loop containing signals x_1, x_2, \dots, x_n having event sets $E(x_1), E(x_2), \dots, E(x_n)$ respectively. The topological loop is an apparent causal loop, if and only if, it is not a buffered loop and there exists an instant where all signals in the topological loop have an event. $S \in \Upsilon$, $\forall_{i=1}^n, \exists e \in E(x_i) \wedge e \triangleright S$.

`Spec1` is a program rejected after causality analysis in Polychrony since the signals `b`, `c` and `d` form an apparent causal loop. Current versions of `EmCodeSyn` will do the same by detecting a possible logical instant ($b_b \wedge b_c \wedge b_d = true$) resulting in an apparent causal loop. Due to the nature of primitives such as `Merge` and `default` where a lower priority input might get ignored, a signal with an event does not mean there exists a causal loop with cyclic data dependency. We have demonstrated this using our example `Spec1`.

Definition 10 (False Causal Loop): Consider an apparent causal loop with signals x_1, x_2, \dots, x_n having event sets $E(x_1), E(x_2), \dots, E(x_n)$. An apparent causal loop is considered to be a false causal loop, if and only if, for no instant in Υ , there exists a data dependency between events $e_n \in E(x_n)$ with the events $e_1 \in E(x_1)$ and for signals x_1, x_2, \dots, x_{n-1} there exists a data dependency between events $e_i \in E(x_i)$ with the events $e_{i+1} \in E(x_{i+1})$.

Definition 11 (True Causal Loop): A true causal loop is an apparent causal loop which is not a false causal loop.

If the edges of a loop have events that never happen on the same logical instants, it is a false causal loop. A reason for incorrect rejection of programs due to false causal loops is the weakness of intermediate structures used for analysis. Clock analysis alone cannot entirely guarantee presence of an event, due to dependency on values of functional computation units as demonstrated by our example `Spec2`. Neither clock calculus of Polychrony nor Boolean epoch analysis of `EmCodeSyn` can fully capture the actual data dependencies in their intermediate structures. We believe satisfiability modulo theories are capable of accommodating these requirements. Hence,

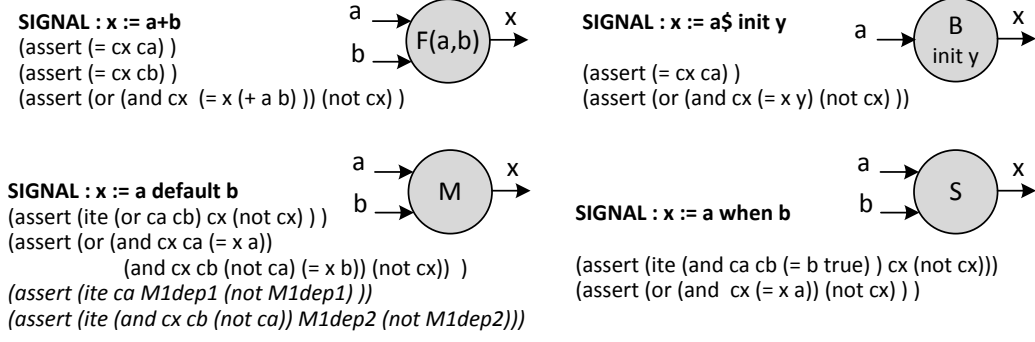

Fig. 5. SMT equations for MRICDF/SIGNAL primitives

they are chosen to distinguish between true and false causal loops.

A. Detection of true causal loops using SMT solvers

Satisfiability (SAT) of a Boolean formula implies there exists a solution to the encoded problem. Satisfiability Modulo Theory (SMT) extends SAT by checking satisfiability of formula over multiple theories such as Boolean, Integer and so on [14]. Our chosen SMT solver Yices version 1.0.29 has a representation format which uses assertions with other common operators. The SMT representation of MRICDF/SIGNAL primitives is summarized in Figure 5.

A signal x is encoded by an epoch variable cx of Boolean type and a data variable x of same type as the signal. The epoch equations of Function and Buffer actors are shown as direct equations of input and output epoch variables in Figure 5. For Sampler and Merge, epoch equations are represented in a conditional *if-then-else* statement. Let us discuss Merge actor in detail, where the epoch equation is of the form ‘**if any of the input epoch variables are true, then output epoch variable is true, else output epoch is false**’. For data equations, the appropriate data dependency is chosen according to input firing conditions. In Merge data equation, the respective data dependencies are chosen according to the output variable value of cx along with the presence or absence of input epoch variables ca and cb . To make the analysis of cyclic dependencies easier, we put additional data dependency variables $M1dep1$ and $M1dep2$ to show the data dependency between input ports of the Merge actor with the output port. Note that only one among the data dependency variables can be true in a logical instant. This will help in determining flow of data in Merge actor along with favorable clock conditions in a loop.

Theorem 2 (True causal loop detection procedure): Given an MRICDF network M represented by the SMT formula set S_M and a set of causal loop candidates C represented by the SMT formula S_C , $\forall S_C^i \in C$, if $S_M, S_C^i \models true$, then the MRICDF network has a true causal loop S_C^i .

Proof sketch: For an SMT formula to be satisfiable, there exists at least one valid assignment to all the variables in the formula. The SMT formula set S_M is representative of any arbitrary instant $P \in \Upsilon$ of the MRICDF network M . The new SMT formula S_M, S_C^i is representative of all instants of MRICDF network where causal loop condition exists, denoted by Υ^i .

To prove that a given causal loop condition S_C^i is a **true causal loop**, we need to prove that any instant L where S_C^i holds, is in Υ . If $S_M, S_C^i \models true$, the SMT solver result is **satisfiable**. There exists at least one valid assignment to all the variables in the formula, or one instant of the MRICDF network with the causal loop. Hence it is a true causal loop ($\Upsilon^i \neq \phi$). If $S_M, S_C^i \models false$, the SMT solver result is **unsatisfiable**. This means there is no valid assignment to the variables in the formula. In other words, there does not exist any instant where the causal loop condition holds. Hence, S_C^i represents a **false causal loop** ($\Upsilon^i = \phi$). ■

The SMT representation for `Spec1` in Figure 1 is given in Figure 6 (a). All signal definitions are of Boolean type and some are omitted in the figure. A *triviality condition* is added after the translation to remove the stuttering instant where no events can occur. Assertion 10 restricts the SMT equations to those instants where at least one signal has an event. Assertion 11 represents the causal loop condition under test. An UNSAT result is obtained from the SMT solver confirming the candidate to be a false causal loop.

The SMT representation for `Spec2` with the clock constraint `C1` and data computation for `trigger` signal is shown in Figure 6 (b). Due to the clock constraint, a continuous stream of events is guaranteed at `ain`, `d` and `trigger`. The data computation constraint `D1 trigger := false when (ain >5 and ain <2) default true` is implemented using three MRICDF actors F_2 , S_2 , and M_2 . The apparent causal loop (`b` \rightarrow `c` \rightarrow `b`) is realizable only when a *false* value is obtained at `trigger`. An UNSAT result is obtained verifying it to be false causal loop. When the data computation constraint is altered to `trigger := false when (ain >0 and ain <2) default true`, we did obtain a SAT result, reaffirming the possibility of a true causal loop.

Presence of a true causal loop does not mean the generated code will encounter the causal loop condition during execution. The realizability of causal loop condition using SMT technique does

```

(set-evidence! true)
(define ca::bool)
(define a::bool)
(define cb::bool)
(define b::bool)
..
(define cclk::bool)
(define M1dep2::bool)
(define M2dep2::bool)

;;M1 b := a default d
1 (assert (ite (or ca cd) cb (not cb)))
2 (assert (or (and cb ca (= b a))(and cb cd(not ca)(= b d)
              (and (not cb)(not ca)(not cd))))))

;;M2 d := e default c
3 (assert (ite (or ce cc) cd (not cd)))
4 (assert (or (and cd ce (= d e))(and cd cc(not ce)(= d c)
              (and (not cd)(not ce)(not cc))))))

;;F1 c = b
5 (assert (= cc cb))
6 (assert (or (and cc (= c (not b))) (not cc)))

;;External Clock Constraints
7 (assert (= cclk (or ca ce)))
8 (assert (ite (and cclk (= true clk)) (= ca true)(= ca false)))
9 (assert (ite (and cclk (= false clk)) (= ce true)(= ce false)))

;;Triviality Condition
10 (assert (= (or ca ce cclk cd cc) true))

;;Causal loop condition
11 (assert (and cb cc cd M1dep2 M2dep2))
(check)
(a) Spec1 : A false causal loop

;;S1 a := ain when trigger
1 (assert (ite (and cain ctrigger (= trigger true)) ca (not ca) ))
2 (assert (or (and ca (= a ain)) (not ca) ))

;;M1 b := a default c
3 (assert (ite (or ca cc) cb (not cb)))
4 (assert (or (and cb ca (= b a)) (and cb cc (not ca) (= b c))(not cb)))
5 (assert (ite ca M1dep1 (not M1dep1) ))
6 (assert (ite (and cb cc (not ca)) M1dep2 (not M1dep2) ))

;;F1 c := b+d
7 (assert (= cc cb))
8 (assert (= cc cd))
9 (assert (or (and cc (= c (+ b d) )) (not cc) ))

;;F2 f2out := ain >5 and ain <2 :D1
10 (assert (= cf2out cain))
11 (assert (or (and cf2out (ite (and (> ain 5) (< ain 2))
                              (= f2out true) (= f2out false))) (not cf2out)))

;; S2 s2out := false when f2out :D1
12 (assert (ite (and true cf2out (= f2out true)) cs2out (not cs2out)))
13 (assert (or (and cs2out (= s2out false)) (not cs2out) ))

;; M2 trigger := s2out default true :D1
14 (assert (ite (or cs2out true) ctrigger (not ctrigger) ))
15 (assert (or (and ctrigger cs2out (= trigger s2out))
              (and ctrigger true (not cs2out) (= trigger true) ) (not ctrigger)))

;;External Clock Constraints C1
16 (assert (= cain cd))
17 (assert (= cain ctrigger))
;;Triviality Condition
18 (assert (= (or ca cb cc cd cain ctrigger cs2out cf2out) true))
;;Causal loop condition
19 (assert (and cb cc M1dep2))
(a) Spec2 with constraints C1 & D1 : A true causal loop

```

Fig. 6. Distinguishing between causal loops using SMT solvers

not check if the MRICDF network can arrive at the state where the causal loop conditions hold, from a given initial state. *Spec3*, a modified version of the MRICDF network *Spec2*, where clock constraint *C1* is applied and the *trigger* signal is determined by another computation is shown in Figure 7 (a). Two incremental buffered counters *x* and *y* are shown with different initial values. Their increment operation is dependent on two signals having the same epoch, thereby equating the number of increments on them. The *trigger* signal is set to *false*, forming the true causal loop ($b \rightarrow c \rightarrow b$) only when *x* and *y* have the same value. With the initial conditions being different and the number of increments being the same, the true causal loop condition is not reachable. The SMT technique can identify the true causal loop, but cannot predict if the loop will ever occur in the course of execution of the generated code. Additional reachability analysis using model checkers is required for this purpose. The causal loop types and the set of tools that are capable of detecting each of them is shown in Figure 7 (b). Current versions of Polychrony and EmCodeSyn are capable of identifying only up to apparent causal loops.

```

process Spec3 =
  (? integer ain, d;
  ! integer b; )
  (| a := ain when trigger %S1%
  | b := a default c %M1%
  | c := b + d %F1%
  | ain ^= d ^= trigger %C1%
  | x := (x$ init 1 + 1) when ^ain default 0
  | y := (y$ init 0 + 1) when ^d default 0
  | trigger := false when (x == y) default true
  )
  where integer a, c, x, y;
  boolean trigger;
end;

```

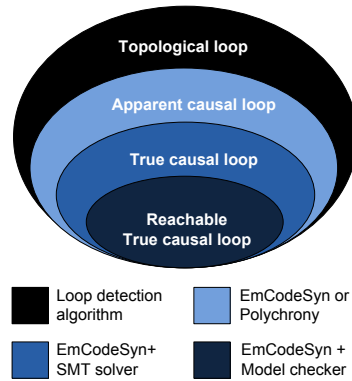

(a) Spec3: Polychronous specification for reachability test (b) Causal loop types and tools used for their detection

Fig. 7. Reachability test for polychronous specification and causal loop types

EmCodeSyn is now automated with SMT solvers and model checkers to verify the presence of true causal loop and reachable true causal loop respectively.

B. Reachability of true causal loops

A recent work has shown how to embed polychronous specifications into synchronous ones in the form of MRICDF/SIGNAL to Quartz conversion [39]. The Averest tool was used to generate smv files from Quartz programs to determine if causal loops are constructive. A few of the Quartz representations for MRICDF actors are shown in Figure 8. MRICDF clock inputs are always represented as read only inputs (denoted by ?) from the environment, while MRICDF output signals are treated as read-write type, since they are written and read from modules. The imperative style code has the functionality of an actor (say MergeInt) expressed as epoch and data constraints. Primitive actors are instantiated, while clock or triviality conditions are expressed as ‘assume’ statements. More information on embedding polychronous processes into synchronous modules is available in [39].

The example Spec2 with constraint C_1 can be represented as a Quartz program as shown in Figure 9 (a). The standard actors M_1 and S_1 are instantiated from a library and the custom F_1 actor is part of the ‘loop’ in Quartz code. The clock constraints and triviality conditions are represented as ‘assume’ statements, while the apparent causal loop is represented as ‘assertion A_1 ’. This property ‘E F causal loop condition’ would ask if the causal loop is a true causal

```

module BufferBool(
  event bool ?clk_i, ?i, ?clk_o, o,
  bool ?init)
{
  bool q = init
  loop {
    if (clk_i) {
      next(q) = i;
      o = q;
    }
    assume(clk_o == clk_i);
    pause;
  }
}

```

(a) Buffer Boolean

```

module MergeInt(
  event bool ?clk_i1, event int{128} ?i1,
  event bool ?clk_i2, event int{128} ?i2,
  event bool ?clk_o, event int{128} o,
  event bool dep1, dep2 )
{
  loop {
    if (clk_i1) {
      o = i1;
      dep1 = true; dep2 = false; }
    else if (clk_i2) {
      o = i2;
      dep1 = false; dep2 = true; }
  }
  assume ((dep1 & dep2) == false);
  assume( clk_o == (clk_i1 | clk_i2));
  pause;
}

```

(b) Merge Integer

```

module SamplerInt (
  event bool ?clk_i1, event int{128} ?i1,
  event bool ?clk_i2, ?i2,
  event bool?clk_o, event int{128} o)
{
  loop {
    if(clk_i2 & i2 & clk_i1){
      o = i1;
    }
    assume((clk_i2&i2&clk_i1) == clk_o);
    pause;
  }
}

```

(c) Sampler Integer

Fig. 8. Quartz modules for MRICDF/SIGNAL primitives

loop and if it can be reached. Its equivalent representation $A2$ has been found to be more time efficient with the Cadence SMV model checker [41]. Reachability is not an issue for $Spec2$ since there are no buffers in the specification. There are no initial conditions and no transitions between states for $Spec2$. In $Spec3$, where $trigger$ is a computation based on a buffer output, both initial conditions and possible transitions matter. Figure 9 (b) shows a shortened Quartz representation of $Spec3$. The same assertion is posed as the model checking problem and it is verified that the true causal loop is not reachable with the given initial conditions. It was also verified that with identical initial values on x and y , or with favorable increment counts, the true causal loop was reachable.

The relative advantage of model checking approach as opposed to SMT approach is in reachability analysis of the causal loop state. Given a set of initial conditions, our MRICDF/Quartz transformation tool provides an infrastructure to see if the apparent causal loop is a true causal loop and also if it is reachable. The model checking time for $Spec2$ amounts to a few seconds, whereas SMT technique can perform true casual loop evaluation for $Spec2$ in a matter of milliseconds. Table II summarizes the time required to detect causal loops in MRICDF networks. [42] contains more information on the functionality of each MRICDF network. There are no restrictions on Integer variable size, but certain operations such as multiplications are not possible in SMT format. The number of actors in each network, the Boolean and Integer buffer counts are shown in columns 2,3, and 4 respectively. We add a simple 2 actor false causal loop (FCL) to each of these networks for computing the FCL detection time. Similarly a true causal loop

```

import Signal.*;
module Spec2 (
  event bool ?clk_a, event int{128} a,
  ...
  event bool ?clk_trigger, event bool ?trigger,
  event bool M1dep1, M1dep2 )
{ M1: MergeInt (clk_a, a, clk_c, c, clk_b, b, M1dep1, M1dep2);
  ||
  S1: SamplerInt (clk_ain, ain, clk_trigger, trigger, clk_a, a);
  ||
  loop{
    //F1 functionality
    if (clk_b)
      c = b+d;

    assume (clk_b == clk_c); //F1 constraint
    assume (clk_c == clk_d); //F1 constraint
    assume (clk_ain == clk_d); // clock constraints 1
    assume (clk_d == clk_trigger); // clock constraints 1
    //assume (clk_trigger -> trigger); // uncomment for constraint2

    //triviality condition
    assume ( (clk_a | clk_b | clk_c | clk_d |
             clk_ain | clk_trigger) == true);
    pause;
  }
}
satisfies {
  A1: assert E F (clk_b & clk_c & M1dep2);
  A2: assert A G ((!clk_b) | (!clk_c) | (!M1dep2));
}
}

```

(a) Generated Quartz program for Spec2

```

import Signal.*;
module Spec3 (
  event bool ?clk_a, event int{128} a,
  ...
  event bool M4dep1, M4dep2, ..., M1dep1, M1dep2 )
S1: SamplerInt (ca, ain, ctrigger, trigger, ca, a);
||
M1: MergeInt (clk_a, a, clk_c, c, clk_b, b, M1dep1, M1dep2);
||
B1: BufferInt (clk_$x, $x, clk_PlusX, PlusX, 1);
||
B2: BufferInt (clk_$y, $y, clk_PlusY, PlusY, 0);
..
loop{ if (clk_c) //F1
  c = b+d;
  assume ( clk_c == clk_b );
  assume ( clk_c == clk_d );

  if (clk_x) //F2
    {(if (x==y) xyeq = true;}
    assume ( clk_x == clk_y );
    assume ( clk_x == clk_xyeq );
  }
  ..
  assume (clk_ain == clk_d); // clock constraints 1
  assume (clk_d == clk_trigger); // clock constraints 1
  //Triviality condition
  assume ( (clk_a | clk_b | ... | clk_trigger) == true);
  pause;
}
}
satisfies {
  A1: assert A G ( (!clk_b) | (!clk_c) | (!M1dep2) );
}
}

```

(b) Generated Quartz program for Spec3

Fig. 9. Quartz representation of Spec2 and Spec3

(TCL) is added to the network and their detection times are reported in columns 5 and 6. Now we perform model checking on each MRICDF network with Integer variables capable of representing $[-128, 127]$ (Range1 - column 7) and $[-512, 511]$ (Range 2 - column 8). We can observe that for a given range, SMT technique has significantly better TCL detection time. As the range is increased further, there is a longer wait time which is not desirable for an interactive programming tool. In conclusion, it is our opinion that performing SMT based causality analysis is more efficient in distinguishing between true and false causal loops. Also, only on confirmation of a true causal loop, reachability analysis before synthesis is justified.

The heuristic implemented in EmCodeSyn to fully automate our causality analysis improvements is shown in Algorithm 1. The goal of this approach is to obtain the best causality detection result with minimal analysis time. Once apparent causal loops are detected by EmCodeSyn, the MRICDF network M is converted to SMT formula S_M . The causal loop candidates are also converted as SMT assertions S_C . Now *True causal loop detection procedure* is applied using an SMT solver to see if a given candidate is a true causal loop. If a Satisfiable result is obtained,

MRICDF Network	# of actors	Buffer Count		SMT - Time in sec		MC - Time in sec	
		Boolean	Integer	FCL	TCL	Range 1	Range 2
Height Supervisor	7	0	0	0.109	0.094	0.188	0.844
Absolute	10	0	0	0.094	0.093	0.219	5.219
Factorial	10	2	0	0.094	0.094	5.156	98.078
Resettable Counter	10	1	0	0.93	0.109	0.109	0.266
Watchdog Timer	16	2	0	0.125	0.109	2.656	16.391
pEBBH	16	1	2	0.125	0.125	0.25	0.234
pSELF	34	6	3	0.203	0.188	1.89	7.859

TABLE II

TIME REQUIRED TO DETECT CAUSAL LOOPS IN MRICDF NETWORKS

it is added into C_R for further reachability analysis. If there are true causal loops in C_R , model checking has to be performed. Each MRICDF network M with its initial conditions $init$ is converted into smv formula. The true causal loop under test is posed as a reachability problem. If the relevant property is verified to be true, then the true causal loop is declared as a reachable true causal loop. This heuristic ensures that the false causal loop identification feature of SMT technique is applied so as to minimize analysis time. Reachability analysis is performed only when a true causal loop is identified.

V. SOFTWARE SYNTHESIS FROM MRICDF SPECIFICATION USING SMT SOLVERS

Beyond causal loop detection, the sequential synthesis conditions for MRICDF include master trigger detection and follower set identification. A follower set is found by a repeated application of *Test For Master Trigger Signal* with a simplification process with the master trigger variables set to *true*. The master trigger detection test using a prime implicate generator is the most time consuming step in EmCodeSyn design flow. In this section, we discuss how SMT solvers are used to perform the master trigger test to speed up software synthesis.

A. Master trigger test

The test for identifying master trigger signal is based on Theorem. 1, which uses the property of a master trigger signal, i.e., if a master trigger signal is absent, no other signal can be present.

```

/* Find C, the set of apparent causal loops in M */
C = Find_ApparentCL(M)
if C ≠ ∅ then
  /* Convert MRICDF M to SMT formula S_M */
  S_M = Convert_MRICDFtoSMT(M)
  S_C = Convert_MRICDFtoSMT(C)
  /* Test satisfiability of the SMT formula with causal loop
  assertion */
  for S_C^i ∈ S_C do
    if S_M, S_C^i ⊨ true then
      /* Add true causal loop C^i to the set C_R for
      reachability analysis */
      C_R ← C_R • C^i
    end
  end
end
if C_R ≠ ∅ then
  /* Convert MRICDF M to SMV V_M */
  V_M, t_init = Convert_MRICDFtoSMV(M, init)
  /* Generate causal loop property SPEC (A G (not (C_R ))) */
  P_R = Generate_CausalLoopProperties(C_R)
  /* Model checking for causal loop C_M^i on MRICDF model M
  with initial state */
  for P_R^i ∈ P_R do
    if V_M, t_init ⊨ P_R^i then
      /* Add C_M^i as a reachable true causal loop in M */
      C_L ← C_L • C_M^i
    end
  end
end

```

Algorithm 1: To find reachable true causal loops

The SMT method for performing this test is to encode the test as a satisfiability problem. There is a constraint added (*at least one clock variable has to be true*) to avoid the trivial solution (*all Boolean variables are false*). Since a root clock signal has to be present for every instant, setting root clock Boolean variable to *false* will turn every Boolean variable to *false*, indicating the absence of an instant without root clock event. This trivial solution has already been avoided, thus a contradiction (UNSAT result) is obtained from an SMT solver.

For an MRICDF network consisting of signals x_1, x_2, \dots, x_n , the *MRICDF-SMT translation* is performed to convert epoch equations to SMT assertions as given in Figure 5. A *triviality condition* (here `assert (= true (or cx1 cx2 ... cxn))`) is added to remove the solution where all variables are *false* (i.e. $cx_1 \cup cx_2 \cup \dots \cup cx_n = false$). Finally, a *master trigger condition* is added, where the master trigger candidate signal is set to *false*. The solutions to the SMT formula are the various combinations of values to the clock variables, representing all possible outcomes in various instants of the MRICDF network. To summarize, the SMT method of master trigger testing has two possible results:

- 1) If the constructed SMT formula is **satisfiable**, there is no conflict between triviality condition and master trigger condition. This implies there is a valid instant with a clock signal other than the master trigger candidate. So the candidate is **not the master trigger**.
- 2) If the constructed SMT formula is **unsatisfiable**, there is a conflict between triviality condition and master trigger condition. Master trigger signal being false, forced every other signal to be false, and hence the candidate **is the master trigger**.

B. Follower set generation

Follower set generation involves a repeated master trigger identification process, firstly for the whole MRICDF network and later for its simplified MRICDF networks. Figure 6 (a) shows the MRICDF-SMT translation with the causal loop condition for `Spec1`. The MRICDF network, the clock constraints and the triviality condition are common to each stage of the follower set generation step. Follower set generation process replaces the *causal loop condition* (assertion 11), with the *master trigger condition*. To obtain the first element, i.e., the master trigger signal, the master trigger condition (`assert (= cb false)`) is added which checks for a contradiction with triviality condition as explained in previous section. The master trigger variable `cb` returns an UNSAT result, confirming `b` as a master trigger signal. Signals `c`, `d` and `clk` return the

same result, forming the first element of the follower set. For subsequent follower set steps, these Boolean variables are set to *true* and a simplified set of Boolean equations are obtained. After expressing them as SMT assertions, a combination of Boolean variables are set to *false*. Boolean clauses such as $(ca + ce)$, $([cclk] + ce)$ provide an UNSAT result due to a contradiction with the triviality condition. An assertion for the test would be $(\text{assert } (= (\text{or } ca \ ce) \ \text{false}))$. Thus, the follower set generation process is performed without a prime implicate generator, fulfilling the alternative route proposed in Figure 4.

We compare the master trigger detection time for different MRICDF networks in Table III. Earlier implementations of our Boolean theory approach had high synthesis time as shown in column 3 (Original) of Table III. For non-endochronous polychronous specification, the time to report the absence of master trigger is shown in the table. Our actor elimination technique (AET) [17] reduced the synthesis time by giving optimized Boolean equations to the time consuming PI generator. The alternative SMT methodology at the Boolean level outperforms both these enhancements by several orders of magnitude as shown in the column 5 (SMT). Polychrony tool takes at most a few seconds for compilation for all the above mentioned examples. It is difficult to separate Polychrony clock hierarchy determination time and we do not claim EmCodeSyn to be faster. For EmCodeSyn with prime implicate approach, it is observed that the synthesis time increases for certain large examples, thus harming the practical use of the tool. SMT based master trigger detection is observed to be taking only milliseconds irrespective of program size, thus bringing down synthesis time for EmCodeSyn. More details on EmCodeSyn code generation are given in [12]. In conclusion, embracing the SMT route for implementing Boolean theory based software synthesis is beneficial in improving the causality analysis of polychronous programs as well as the software synthesis time.

VI. CONCLUSIONS

In this paper, we evaluated the sequential synthesis conditions from polychronous specification. In particular, causality analysis of polychronous specifications were shown to be insufficient in the two available synthesis tools. We have proposed an SMT based causality analysis approach which was shown to be sufficient in detecting the false causal loops from a set of apparent causal loops. Existing works have explored model checking for causality analysis, but experimental evidence shows that they are time consuming. We implemented a heuristic which limits the

MRICDF Network	# of actors	Time in seconds		
		Original	AET	SMT
Height Supervisor	5	0.35	0.37	0.094
Absolute	8	0.91	0.91	0.078
Factorial	8	0.33	0.33	0.09
Resettable Counter	8	0.927	0.562	0.099
Watchdog Timer	14	16.3	5.3	0.11
Producer-Consumer	15	21.4	16.3	0.12
Flight Warning System	17	8.1	1.03	0.1
GCD	19	1.35	0.89	0.13
pEBBH	14	0.79	0.75	0.125

TABLE III

TIME REQUIRED TO FIND MASTER TRIGGER SIGNAL

use of model checker to only true causal loops separated after the SMT causality analysis step. Another issue regarding polychronous tools was synthesis time. Polychrony had low synthesis time, which could not be replicated in EmCodeSyn’s Boolean theory approach due to long prime implicate computation period. We have shown that prime implicate computation can be posed as a satisfiability problem which can reap benefits of recent improvements in SAT/SMT solvers. An alternate SMT route for synthesis within the EmCodeSyn design methodology was implemented and the synthesis time was reduced when compared with the prime implicate route.

Finally, the integration of verification tools with EmCodeSyn is found to be beneficial for software synthesis from polychronous specification. Our solutions can also be implemented as a part of the Polychrony compiler. There are opportunities in unrolling the SMT model to explore reachability of causal loop condition. This would provide a structure for model checking that has lesser number of states than the Quartz transformation. Reducing the number of states to be explored can further improve causal loop detection time. Our future work would be in these two fronts for enhancing the capabilities of EmCodeSyn software synthesis tool.

acknowledgement

We acknowledge the contributions of Jens Brandt, Mike Gemunde and Klaus Schneider from University of Kaiserslautern. This research has been partially supported by Air Force Office of Scientific Research, Air Force Research laboratory, and National Science Foundation.

REFERENCES

- [1] O. Tardieu and R. de Simone. Curing schizophrenia by program rewriting in esterel. In *Formal Methods and Models for Co-Design, 2004. MEMOCODE '04. Proceedings. Second ACM and IEEE International Conference on*, pages 39 – 48, june 2004.
- [2] N. Halbwachs and F. Maraninchi. On the symbolic analysis of combinational loops in circuits and synchronous programs. In *Euromicro'95, Como (Italy), September 1995*.
- [3] P. L. Guernic, M. Borgue, T. Gauthier, and C. Marie. Programming real time applications with SIGNAL. *Proc. of the IEEE*, 79(9):1321–1335, 1991.
- [4] Olivier Maffeis and Paul Le Guernic. *Distributed Implementation of SIGNAL: Scheduling & Graph Clustering. In Lec. Notes in Comp. Sc.*, volume 863. Springer-Verlag Publishers, 1994.
- [5] Pascal Aubry, Paul Le Guernic, and Sylvain Machard. Synchronous distribution of signal programs. In *29th Hawaii Intl. Conf. on System Sciences*, volume 1, pages 656–665, 1996.
- [6] Bijoy A. Jose and Sandeep K. Shukla. An Alternative Polychronous Model and Synthesis Methodology for Model-Driven Embedded Software. In *Proc. of 15th Asia and South Pacific Design Automation Conference(ASPDAC)*, pages 13–18, 2010.
- [7] Bijoy A. Jose and Sandeep K. Shukla. MRICDF : A polychronous Model for Embedded Software Synthesis. *Springer: Synthesis of embedded software - frameworks and methodologies for correctness by construction software design*, 2010.
- [8] Paul Le Guernic, Thierry Gautier, Michel Le Borgne, and Claude Le Maire. Programming real-time applications with signal. *Proc. of the IEEE*, 79(9):1321–1336, 1991.
- [9] ESPRESSO Project, IRISA. The Polychrony Toolset. <http://www.irisa.fr/espresso/Polychrony/>.
- [10] J.-P Talpin, J. Ouy, L. Besnard, and P. Le Guernic. Compositional design of isochronous systems. In *Design, Automation and Test in Europe (DATE'08)*, pages 928–933, March 2008.
- [11] EmCodeSyn: A visual software synthesis tool for polychronous specifications. http://www.fermat.ece.vt.edu/?page_id=165.
- [12] Bijoy A. Jose and Sandeep K. Shukla. New Techniques for Sequential Software Synthesis from a Polychronous Data Flow Formalism. <http://www.fermat.ece.vt.edu/Publications/pubs/techrep/MRICDFJournal-techrep.pdf>, 2011.
- [13] Saurabh Srivastava, Sumit Gulwani, and Jeffrey S. Foster. From program verification to program synthesis. In *Proc. of the 37th ACM SIGPLAN-SIGACT symp. on Principles of programming languages*, POPL'10, pages 313–326, 2010.
- [14] L. de Moura and N. Bjorner. Satisfiability modulo theories: An appetizer. *Lecture Notes in Computer Science*, 5902:23–36, 2009.
- [15] Clark Barrett, Morgan Deters, Albert Oliveras, and Aaron Stump. Satisfiability Modulo Theories Competition (SMT-COMP) . <http://www.smtexec.org/exec/?jobs=684>, 2010.
- [16] A. Matusiwickz, N. Murray, and E. Rosenthal. Prime Implicate Tries . In *Proc. of 18th Intl. Conf. on Automated Reasoning with Analytic Tableaux and Related Methods*, Oslo, Norway, 2009.
- [17] Bijoy A. Jose, Jason Pribble, and Sandeep K. Shukla. Faster embedded software synthesis using actor elimination techniques for multi-rate synchronous formalism. In *Proc. of 10th Conf. on Application of Concurrency to System Design (ACSD)*, pages 147–156, June 2010.
- [18] Bijoy A. Jose, Abdoulaye Gamatie, Julien Ouy, and Sandeep K. Shukla. SMT Based False Causal loop Detection during Code Synthesis from Polychronous Specifications. <http://fermat.ece.vt.edu/Publications/pubs/techrep/techrep1104.pdf>, July 2011. Proc. of 9th ACM/IEEE International Conference on Formal Methods and Models for Codesign (MEMOCODE).
- [19] N. Halbwachs. Synchronous Programming of Reactive systems. *Kluwer Academic Publishers, Netherlands*, 1993.

- [20] Grard Berry and Georges Gonthier. The esterel synchronous programming language: design, semantics, implementation. *Science of Computer Programming*, 19(2):87 – 152, 1992.
- [21] F. Boussinot and R. De Simone. The ESTEREL language. *Proc. of the IEEE*, 79(9):1293–1304, September 1991.
- [22] Synfora Inc. Esterel Studio EDA Tool. <http://www.synfora.com/products/esterelStudio.html>.
- [23] Stepher A. Edwards and Jia Zeng. Code Generation in the Columbia Esterel Compiler. *EURASIP J. on Embedded Systems*, 2007:1–31, 2007.
- [24] K. Schneider. The synchronous programming language Quartz. Internal Report 375, Department of Computer Science, University of Kaiserslautern, Kaiserslautern, Germany, December 2009.
- [25] K. Schneider and T. Schuele. Averest: Specification, verification, and implementation of reactive systems. In J. Desel and Y. Watanabe, editors, *Application of Concurrency to System Design (ACSD)*, St. Malo, France, 2005. Participant’s proceedings.
- [26] N. Halbwachs, P. Caspi, P. Raymond, and D. Pilaud. The Synchronous Data-Flow Programming Language LUSTRE. *Proc. of the IEEE*, 79(9):1305–1320, September 1991.
- [27] ESTEREL Technologies. SCADE suite. www.esterel-technologies.com/products/scade-suite/.
- [28] Paul Caspi and Marc Pouzet. A Functional Extension to Lustre. In M. A. Orgun and E. A. Ashcroft, editors, *International Symposium on Languages for Intentional Programming*, Sydney, Australia, May 1995. World Scientific.
- [29] Sharad Malik. Analysis of cyclic combinational circuits. In *Proc. of the IEEE/ACM Intl. Conf. on Computer-aided design*, pages 618–625, 1993.
- [30] G. Berry. The constructive semantics of pure esterel, 1996.
- [31] Thomas Shiple, Gerard Berry, and Herve Touati. Constructive analysis of cyclic circuits. In *Proceedings of the 1996 European conference on Design and Test*, pages 328–, 1996.
- [32] Kedar S. Namjoshi and Robert P. Kurshan. Efficient analysis of cyclic definitions. In *Proceedings of the 11th International Conference on Computer Aided Verification, CAV ’99*, pages 394–405. Springer-Verlag, 1999.
- [33] Olivier Tardieu and Robert De Simone. Instantaneous termination in pure esterel. In *Proceedings of the 10th international conference on Static analysis, SAS’03*, pages 91–108. Springer-Verlag, 2003.
- [34] Marc D. Riedel and Jehoshua Bruck. The synthesis of cyclic combinational circuits. In *In Design Automation Conference (DAC)*, pages 163–168. ACM, 2003.
- [35] E.M. Sentovich. Quick conservative causality analysis. In *System Synthesis, 1997. Proceedings., Tenth International Symposium on*, pages 2 –8, sep 1997.
- [36] Edmund M. Clarke and E. Allen Emerson. Design and synthesis of synchronization skeletons using branching-time temporal logic. In *Logic of Programs, Workshop*, pages 52–71, London, UK, 1982. Springer-Verlag.
- [37] J. Queille and J. Sifakis. Specification and verification of concurrent systems in cesar. In Mariangiola Dezani-Ciancaglini and Ugo Montanari, editors, *International Symposium on Programming*, volume 137 of *Lecture Notes in Computer Science*, pages 337–351. Springer Berlin / Heidelberg, 1982.
- [38] Abdoulaye Gamatié and Laure Gonnord. Static Analysis of Synchronous Programs in SIGNAL for Efficient Design of Multi-Clocked Embedded Systems. In *Proc. of SIGPLAN/SIGBED Conf. on Languages, Compilers, and Tools for Embedded Systems (LCTES’11)*, pages 71–80, April 2011.
- [39] Jens Brandt, Mike Gemunde, Klaus Schneider, Bijoy A. Jose, and Sandeep K. Shukla. Causality Analysis of Polychronous Programs. *FERMAT Technical Report 2011-02*.
- [40] D. Nowak. Synchronous structures. *Inf. Comput.*, 204(8):1295–1324, 2006.

- [41] The Cadence SMV model checker. <http://www.kenmcml.com/smv.html>.
- [42] Bijoy A. Jose, Jason Pribble, and Sandeep K. Shukla. Technical Report on MRICDF models. <https://filebox.vt.edu/users/bijoyaj/files/mricdfmodels.pdf>, 2010. FERMAT Technical Report 2010-01.