



**HAL**  
open science

# PAC-C3D: A New Software Architectural Model for Designing 3D Collaborative Virtual Environments

Thierry Duval, Cédric Fleury

► **To cite this version:**

Thierry Duval, Cédric Fleury. PAC-C3D: A New Software Architectural Model for Designing 3D Collaborative Virtual Environments. ICAT 2011, VRSJ, Nov 2011, Osaka, Japan. pp.53-60. inria-00636143

**HAL Id: inria-00636143**

**<https://inria.hal.science/inria-00636143v1>**

Submitted on 6 Apr 2014

**HAL** is a multi-disciplinary open access archive for the deposit and dissemination of scientific research documents, whether they are published or not. The documents may come from teaching and research institutions in France or abroad, or from public or private research centers.

L'archive ouverte pluridisciplinaire **HAL**, est destinée au dépôt et à la diffusion de documents scientifiques de niveau recherche, publiés ou non, émanant des établissements d'enseignement et de recherche français ou étrangers, des laboratoires publics ou privés.

# PAC-C3D: A New Software Architectural Model for Designing 3D Collaborative Virtual Environments

Thierry Duval \*

Université de Rennes 1, IRISA UMR CNRS 6074, Rennes, France

Cédric Fleury†

INSA de Rennes, IRISA UMR CNRS 6074, Rennes, France

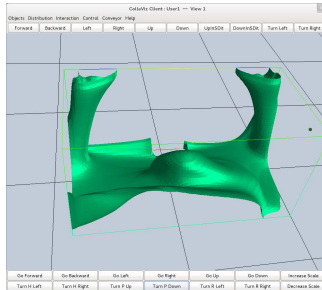

The Java3D Visualizer

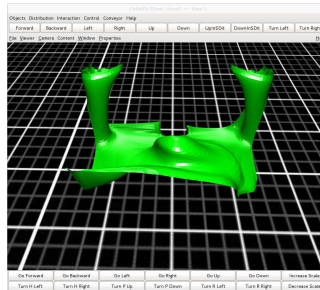

The jReality Visualizer

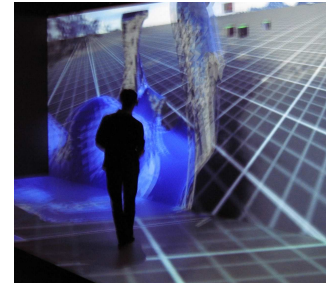

The Immersive jReality Visualizer

Figure 1: Three different visualizers sharing the same virtual environment

## ABSTRACT

We propose PAC-C3D as a new software model for 3D Collaborative Virtual Environments (CVE). This model merges the results from two research fields: distribution models for CVE and HCI design for computer-supported cooperative work. PAC-C3D proposes to describe each part of a shared virtual object through explicit interfaces to ensure a strong separation between the core functions of a virtual environment, its (visual) representations, and its collaborative features such as synchronization and consistency maintenance between remote users. PAC-C3D makes it possible to design a CVE with low dependency between the core functions, the distribution mode and the 3D graphics API used. It explicitly deals with the main distribution modes encountered in CVE. It makes it easy to use different 3D graphics API for different nodes involved in the same collaborative session, providing interoperability between these 3D graphics API. It also makes it possible to integrate other kinds of 3D representations such as physics engines into the CVE.

**Index Terms:** H.5.2 [Information Interfaces and Presentation (e.g., HCI)]: User Interfaces—Theory and methods; H.5.3 [Information Interfaces and Presentation (e.g., HCI)]: Group and Organization Interfaces—Computer-supported cooperative work (CSCW); I.3.7 [Computer Graphics]: 3-Dimensional Graphics and Realism—Virtual reality; D.2.11 [Software Engineering]: Software Architectures—Patterns I.3.6 [Computer Graphics]: Methodology and Techniques—Interaction techniques, Device independence

## 1 INTRODUCTION

The design of 3D Collaborative Virtual Environments (CVE) merges the design of interactive 3D applications and the design of distributed collaborative applications. This task is complex because it must address 3D interaction and immersion issues as well

as collaborative issues dealing with distribution, synchronization, and consistency maintenance of the shared virtual environment.

The configuration (adaptation to the hardware deployment systems) of CVE is complex because it must address various network characteristics (from high bandwidth on professional or experimental networks to low bandwidth on personal networks) as well as various displays and 3D interaction devices (from 6-face *Caves* [8] to simple workstations or even to simple interactive tablets). All these configurations can even be used at the same time in a single deployment in order to make asymmetric collaboration possible between remote users using different input and output devices.

To meet all these requirements, these CVE must be designed according to a software architectural model that makes it possible to adapt the distribution mode of a CVE to solve the network interoperability issues. Such a model should also make it possible to design software components that encapsulate the hardware 3D graphics requirements, in order to be able to choose at run-time the best components for each hardware configuration. Existing solutions focus either on how to manage distribution and consistency maintenance for 3D CVE, or on how to manage independence between core functions and graphics API for 2D CSCW. For now, design models for CVE deal neither with independence to 3D graphics API nor with efficient management of distribution modes.

So we propose to merge these two main research fields in order to provide a new solution, the PAC-C3D model, which offers a better way to design and implement CVE. PAC-C3D meets two requirements: ensure synchronization and consistency maintenance of CVE, and ensure independence of CVE from 3D graphics engines to make interoperability possible between such 3D engines.

In this paper, section 2 presents the context of our work: the need to design CVE with various distribution models. Section 3 presents the software architectural models used in the field of HCI and CSCW. Section 4 presents our new software architectural model and how its instances communicate together. Consistency maintenance is explained in section 5 for each of the main distribution modes. Then section 6 describes how this model can be used to address the problem of interoperability between 3D API, for 3D graphics or physics engines. Finally, section 7 gives some implementation examples illustrating how our model faces adaptation to different distribution situations and to different 3D engines.

\*e-mail: thierry.duval@irisa.fr

†e-mail: cedric.fleury@irisa.fr

## 2 THE CONTEXT: DISTRIBUTED ARCHITECTURES FOR CVE

The location of the virtual environment data (i.e. geometric data, textures, etc.) is a critical decision when designing a CVE system [23]. It determines which nodes (usually the users' computers) store this data, which nodes execute the processing related to each virtual object, and how the synchronization of the distributed objects is achieved. We distinguish three data distribution modes: homogeneously replicated, centralized, and partially replicated [19], which is similar to the approaches presented in [12]. A more complete overview of synchronization and data distribution within CVE can be found in [10, 11, 20].

### 2.1 Duplication: homogeneous replicated world

In replicated CVE systems all nodes are initialized with the same database that contains all the informations about the virtual environment (geometric models, textures, object behaviors, etc.). During a session, the database evolves independently on each node and all object behaviors are executed locally. Object modifications are performed locally before being sent to the other nodes by using update messages.

So latency is very low during user interactions. However, inconsistencies between users' states of the virtual environment can appear because of delays or losses during messages transmissions. Additional mechanisms must also be used to manage concurrent access to the objects to avoid conflicts.

### 2.2 Centralization: shared centralized world

In centralized systems all the CVE data is stored on a central server (client/server network architecture). Similarly, virtual object behaviors are executed on this server. When a user wants to modify an object, he sends a request to the server. The server processes the modification request, then transmits the up-to-date state of the object to all the nodes, including the one that has asked for modification.

This method implicitly ensures consistency between all the nodes and avoids data replication. However, this architecture can introduce latency during user interactions because each modification request has to pass through the server, and a performance "bottleneck" can appear on the server when there are many users.

### 2.3 Hybrid solution: partially replicated world

Many CVE systems choose hybrid solutions between totally centralized and totally replicated data distributions, mixing features to meet particular requirements of consistency and responsiveness. These solutions distribute the data and their processing among the nodes. Most of the time, a referent/proxy paradigm is used for each object. Proxies maintain a local copy of the virtual environment, only receiving update messages from the referent.

This distribution mode makes a trade-off between the advantages and drawbacks of the two other data distributions.

### 2.4 Dynamic solution: mixing all the modes

Some distribution mechanisms, such as the distribution model of the Collaviz system [19] even propose a mix of these three distribution modes, allowing each object to change dynamically at run-time its own distribution mode.

### 2.5 Synthesis about distribution modes

As each distribution mode has its own advantages and drawbacks, a good software architectural model for CVE should be able to manage these three main distribution modes and should be flexible enough to provide solutions for evolution toward new distribution or synchronization modes.

## 3 RELATED WORK: MODELS FOR HCI AND CSCW

A lot of research work about architectural models for human-computer interaction (HCI) deals with separating clearly the graphics part of interactive software from its core part. Some of these models have been adapted to the context of computer-supported collaborative work.

### 3.1 Software architectural models for HCI

The most commonly used software architectural models for HCI are based either on the Model-View-Controller (MVC) model [26, 21] or on the Presentation-Abstraction-Control (PAC) model [7]. Both of them have inspired many models dedicated to particular situations: for example for Struts web-based applications (MVC-2 [9]), for C++ or Java applications (Model-View-Presenter (MVP) [25]) or for multi-modal applications (PAC-Amodeus [24]).

MVC divides interactive components into three parts: the *Model*, the *View* and the *Controller* (see figure 2(a)).

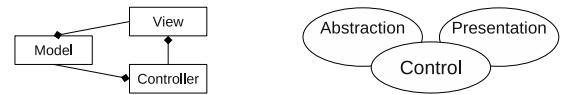

Figure 2: (a) The MVC model — (b) The PAC model

“The *Model* represents data and the rules that govern access to and updates of this data. ... The *View* renders the contents of a *Model*. It specifies exactly how the *Model* data should be presented. If the *Model* data changes, the *View* must update its presentation as needed. This can be achieved by using a push model, in which the *View* registers itself with the *Model* for change notifications, or a pull model, in which the *View* is responsible for calling the *Model*. ... The *Controller* translates the user's interactions with the *View* into actions that the *Model* will perform. ...” [16]

So the *Model* and the *View* of MVC can be closely coupled, contrary to the formal separation achieved by PAC between these two kinds of components.

PAC divides interactive components into three parts: the *Presentation*, the *Abstraction* and the *Control* (see figure 2(b)). At first look, one could consider that PAC is just another name for MVC where *Presentation* could stand for *View*, *Abstraction* could stand for *Model* and *Control* could stand for *Controller*. In practice, the PAC components have a quite different behavior than the MVC components.

“The *Presentation* defines the concrete syntax of the application, i.e. the input and output behavior of the application as perceived by the user. The *Abstraction* corresponds to the semantics of the application, it implements the functions that the application is able to perform. ... The *Control* maintains the mapping and the consistency between the abstract entities involved in the interaction and implemented in the *Abstraction*, and their *Presentation* to the user. It embodies the boundary between semantics and syntax. It is intended to hold the context of the overall interaction between the user and the application.” [7]

So the *Abstraction* and the *Presentation* are not allowed to communicate directly: the *Control* acts as a mediator and filters all the communications between its *Abstraction* and *Presentation*, and with the other *Controls*.

In fact, most of the MVC-like models propose also this separation between the *Model* and the *View*, as detailed in the Oracle/Sun interpretation of MVC [16], which is very similar to the PAC model.

To ensure a better independence between these three kinds of components, the Arch model [27] proposes to add adaptor components between them (see figure 3). This model is also considered as a meta-model for other software models, which should follow this generic separation between facets of interactive components.

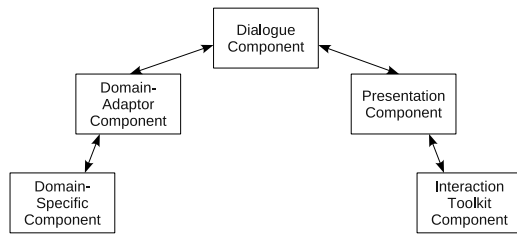

Figure 3: The Arch model

These models must now be extended to manage the collaborative aspects of CVE.

### 3.2 Models for collaborative HCI

Several adaptations of the PAC and Arch models have been proposed to cope with these collaborative features. These approaches rely on Ellis’s conceptual model of groupware [17] or on the clover conceptual model [22]. Ellis’s model proposes three complementary components or models: the ontological model, the coordination model, and the user-interface model. The clover conceptual model proposes to divide the services of collaborative software into three main parts: production, communication and coordination (see figure 4(a)). The ontological model and the production space refer to the shared virtual objects of a CVE. The coordination model and the coordination space cover the consistency maintenance in the CVE. The user-interface model refers to the representation of human-computer interaction while the communication space refers only to the communication between the users of a CVE.

PAC\* [6] (see figure 4(b)) dispatches these three kinds of functions across the three PAC facets. To our opinion, this is a problem for designing *Abstractions* independently from the collaborative aspects.

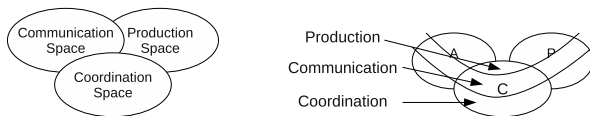

Figure 4: (a) The clover concepts — (b) The PAC\* model

Clover [22] (see figure 5(b)) is an extension of PAC\* that relies on Dewan’s “generic multi-user architecture”[12] (see figure 5(a)), which is a collaborative extension of the Arch model. Here again, each unit of the model can contain three sub-components about production, communication and coordination, especially the higher-level units that correspond to the core of the CVE.

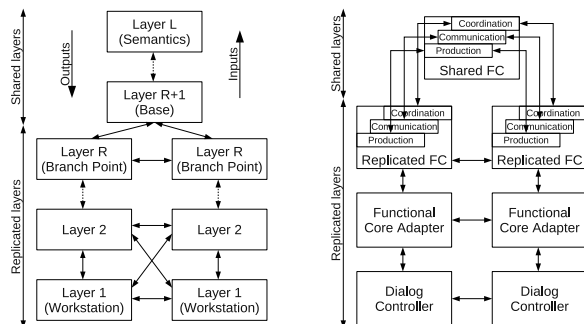

Figure 5: (a) Dewan’s model — (b) The Clover model

### 3.3 Synthesis about HCI models and collaboration

Software architectural models for HCI propose to divide interactive components in three kinds of components that should be as independent as possible from each other. Some of these models have been extended to address the design of CVE, according to the clover conceptual model, but they do not address how to cover the three main distribution modes of the CVE. Furthermore, they spread the collaborative aspects over all the components of the models, which is a problem for designing *Abstractions* that should not be aware of the collaborative aspects.

This is why we need a new model for designing 3D CVE, which would ensure the best possible separation between core functions, visualization (3D graphics API and libraries) and collaboration aspects, and which would provide explicit solutions to achieve these different synchronization modes.

## 4 PAC FOR COLLABORATIVE 3D APPLICATIONS

### 4.1 Interfaces for independence between components

In order to make the PAC facets independent from each other, we choose a special interpretation of the PAC model that proposes interfaces to specify the features of each facet of the model. An important feature of this model is that the *Control* is a *Proxy* (GoF207)[15] of its associated *Abstraction*.

We present figure 6 a new interpretation of this model in order to allow the presence of several *Presentations* associated to the same *Control*. Each virtual shared object will be described through 3 interfaces:

- *Interface for the Abstraction (IA)*: it declares the methods in charge of the object behavior and the methods allowing to set and get its attributes.
- *Interface for the Presentation (IP)*: it declares the methods allowing to set and get the attributes of the representation of the object (for example the position of its 3D visualization).
- *Interface for the Control (IC)*: it declares all the methods of the *Interface for the Abstraction*, as the *Control* will be used to manage the access to the *Abstraction* (the *Control* will be the proxy of the *Abstraction*) to maintain consistency between the *Abstraction* and all the *Presentations*, and some methods dedicated to the communication with its *Presentations* and the other *Controls*.

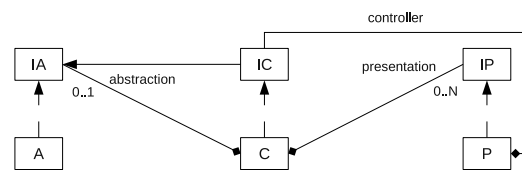

Figure 6: The PAC model with interfaces between facets

As these interfaces will be implemented by the real facets of the PAC components, at run time these facets will be instances of:

- *Abstraction (A)*: it implements the object model and behavior, and the setters and getters.
- *Presentation (P)*: it implements the object representation: for example it can use a 3D graphic API to visualize the object and its properties.
- *Control (C)*: it implements the consistency maintenance between the *Abstraction* and the *Presentations*, and it regulates the access to the *Abstraction*.

Very often, a *Presentation* is closely coupled to a 3D graphics API, but thanks to the *Interface for the Presentation*, the *Control* will be totally independent of this 3D API.

In the same way, thanks to the *Interface for the Control*, the *Presentations* and *Abstraction* will be totally independent from the implementation of the *Control*.

## 4.2 Adapting PAC to collaboration

As for the PAC\* model [6] and the Clover model [22], here again the PAC model will be the basis of our proposition, but unlike these two models, the collaborative parts will not be spread out into all the components of the model, but only into the *Control* of the PAC components.

Indeed, we consider that the objects of the production space should remain in the core parts of a 3D CVE, and that their coordination should be achieved by the *Control* of the PAC components. Last, we consider that communications between users should be either totally integrated within a 3D CVE through shared virtual objects, or totally independent of the 3D CVE, so these communication aspects are not central to a model dedicated to the design of 3D CVE. In our opinion, the distributed aspects should not impact the *Presentations* and *Abstraction* of a PAC component, in the same way that the 3D graphics details should be limited inside the *Presentations* and that the core concepts should remain in the *Abstraction*. This independence is possible thanks to the three interfaces of our model.

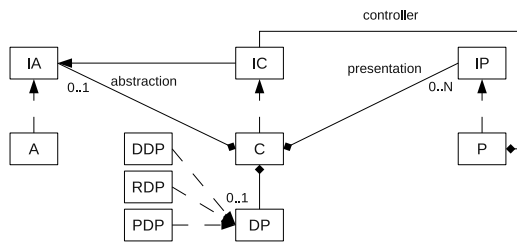

Figure 7: Adaptation of the PAC model for 3D CVE

The *Control* is associated to one distribution policy, dedicated to synchronization and consistency maintenance. There are three distribution policies:

- *Referent distribution policy (RDP)*: implementation of what is needed to manage the set messages and to distribute updates to other *Controls*: each time the value of a parameter of the object is set, this policy makes the referent *Control* send (for example using multicast) an update message to the distributed proxy *Controls* so that they can also update their *Presentations*.
- *Proxy distribution policy (PDP)*: implementation of what is needed to transmit the set messages toward the referent *Control*, and to manage the update messages returned by the referent *Control*: each time the value of a parameter of the object is set, this policy makes the proxy *Control* send a set message to its referent *Control*, and this value will be effectively set only when the proxy *Control* will receive an update message from its referent *Control*.
- *Duplicated distribution policy (DDP)*: same management of the set messages as the RDP, and same management of the update messages as the PDP.

These components will be distributed across the network according to the number of nodes in a collaborative session and to the architecture chosen for the distribution.

## 5 DEALING WITH DISTRIBUTION MODES

In this section we will detail the behavior of PAC-C3D *Controls* according to their associated distribution policy, in order to show that this behavior is able to deal with the three main distribution modes for CVE.

We will consider a modification of the value of a parameter of a virtual object occurring from a presentation component where a user will have made an action upon a shared virtual object, and we will trace the subsequent communications between the PAC-C3D components and facets.

### 5.1 PAC-C3D and duplicated architecture

In a CVE with a typical duplicated architecture, for each shared virtual object there will be as many instances of *Abstractions*, *Presentations* and *Controls* with a duplicated distribution policy (**DDP**) as there are visualization nodes embedding one or several representations of the shared virtual universe.

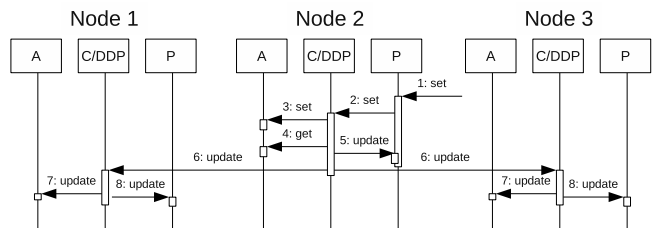

Figure 8: PAC-C3D and duplicated architecture

Figure 8 presents a typical duplicated architecture with three nodes. The exchanges between the facets of the PAC-C3D components will be as follow:

- 1 An action occurs upon the *Presentation* of a virtual object, on one node, to set the value of one attribute of this virtual object. This *Presentation* does not set the attribute, but instead asks its *Control* for a modification.
- 2-5 This *Control* receives the set request and transmits it to its *Abstraction*. This *Abstraction* processes the set requests in its own way: the final value of the attribute of the *Abstraction* can be different from the value proposed by the *Control*, for example because a proposed value could put the *Abstraction* into an incorrect status. This is why the *Control* then asks its *Abstraction* for the effective value of the attribute and updates its *Presentation* with this new value. Then the *Control* transmits this value to the other duplicated *Controls* by sending them an update message (this sending can be synchronous but it is more efficient to make it asynchronous to allow all the duplicated *Controls* to process the update at the same time).
- 6-8 Finally on each other node a duplicated *Control* receives the update message and asks its *Abstraction* and then its *Presentation* for an update.

As we have seen in section 2.1, the main advantage of this architecture is that when a user interacts with an object, he obtains an immediate feedback. Then all the other users may perceive the result of the interaction at the same time, with a delay corresponding to the network latency. The main drawback of this architecture is that it must ensure a strong synchronization between the nodes because of the potential autonomous behavior of some shared virtual objects. It is also quite impossible to allow several users to interact directly at the same time on a same shared virtual object.

## 5.2 PAC-C3D and centralized architecture

In a CVE with a typical centralized architecture, for each shared virtual object:

- there is only one instance of *Abstraction*, on the server,
- there are as many instances of *Presentations* as there are visualization nodes embedding one or several representations of the shared virtual universe,
- there is only one instance of *Control* with a referent distribution policy (**RDP**), without *Presentation*,
- there are as many instances of *Control* with a proxy distribution policy (**PDP**) as there are *Presentation* instances.

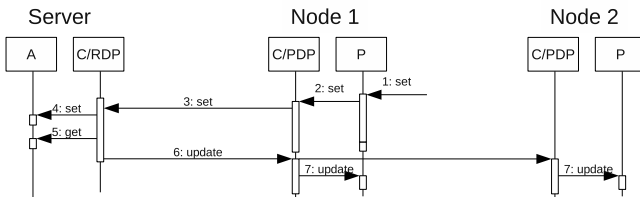

Figure 9: PAC-C3D and centralized architecture

Figure 9 presents a typical centralized architecture with one server and two clients. The exchanges between the facets of the PAC-C3D components will be as follow:

- On one client an action occurs upon the *Presentation* of a virtual object, and this *Presentation* asks its proxy *Control* for a modification. This proxy *Control* transmits the set request to its referent *Control* (this transmission can be synchronous or asynchronous).
- The referent *Control* transmits the value to its *Abstraction*. Here again this *Abstraction* processes the set requests in its own way and then the *Control* asks its *Abstraction* for the effective value of the attribute. Then it transmits to its proxy *Control* by sending them an update message (here again this sending should be asynchronous).
- Finally on each client a proxy *Control* receives the update message and asks its *Presentation* for an update.

As we have seen in section 2.2, the main advantage of this architecture is that all the users may perceive the result of the interaction at the same time, but the drawback is that the delay for the semantic feedback is about twice the network latency. Another interesting property of this distribution policy is that it is not absolutely necessary to have a strong synchronization between all the nodes as all the behaviors are executed on the server node. Last, it is easy to allow several users to interact at the same time with the same object as the referent *Control* will be in charge of centralizing all the interactions coming from all the nodes: it can integrate all the concurrent propositions to compute a single result.

## 5.3 PAC-C3D and hybrid architecture

In order to answer more quickly to a user's interaction with a virtual object, it can be interesting to locate the *Abstraction* of this object on this user's node, which means to allow the referent to be on a client node rather than to stay on a centralized server. So we can consider that the hybrid architecture is a simple evolution of the centralized architecture where all the referents are not necessarily on the same node and where a centralized server is not absolutely necessary any longer.

In such a case, there will be two different situations while interacting with a virtual object, as described figure 10: either the *Abstraction* of the object is on the same node than the user, either it is on another node.

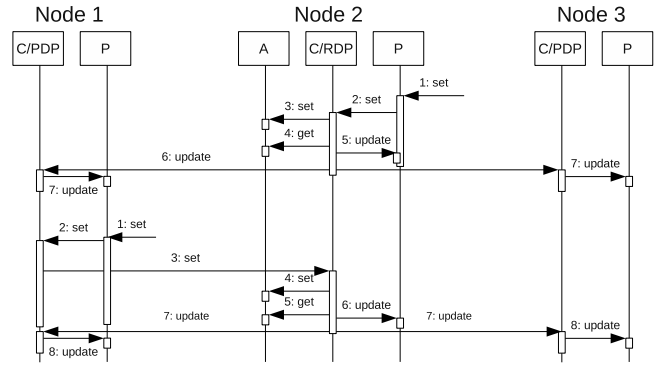

Figure 10: PAC-C3D and hybrid architecture

If the *Abstraction* of the object is on the node of the interacting user, this user will obtain an immediate interaction feedback, while the other users will perceive the interaction with a small lag mainly due to the network latency. This is very similar to the behavior of the duplicated architecture.

If the *Abstraction* of the object is not on the node of the interacting user, the user on the node of the *Abstraction* will be the first to perceive the result of the interaction, and all the other users (even the one who is interacting) will see the result of the interaction at the same time, with a delayed feedback about twice the network latency. This is quite similar to the behavior of the centralized architecture.

In both cases this hybrid solution offers the same possibility as the centralized architecture to enable several users to interact at the same time with a same object. And as we have seen in section 2.3, it also has the same main drawback as the duplicated architecture about the necessity to synchronize all the nodes because each node can be in charge of the behavior of some virtual objects.

## 5.4 Adapting distribution policies

To change the distribution mode of a system designed according to our model, for example to transform a centralized architecture to a hybrid architecture or to a duplicated architecture, we only have to change the distribution policy of the *Controls*: it impacts neither the *Abstractions* nor the *Presentations*. It is even possible to change dynamically the distribution policy of a *Control*, by replacing its current distribution policy by a new one, which allows to meet the requirements of the Collaviz system [19].

In the same way, with a hybrid system it is possible to enable some *Abstractions* to migrate from one node to another and to change the distribution policies of the associated *Controls* to offer a better interaction to a user by placing the *Abstraction* of a virtual object on the user's node. And in the case of concurrent interaction of two users with the same object, it is better for equity to make the *Abstraction* of the co-manipulated object migrate to a third node.

Last, thanks to a precise description of the basic network services, all the network communication details are also limited to basic network policy components. These components implement the communications between the PAC-C3D *Controls* using network facilities such as RPC, RMI, TCP communications (Unicast or Multicast) or HTTP communications. So, to change the basic network layer used by the *Controls*, we only have to provide a new set of distribution policies that rely on the new network layer.

## 5.5 Creation of the shared virtual objects

To ensure an easy evolution of a CVE, we must use the *Abstract Factory* design pattern (GoF87) [15] for object creation. This design pattern makes it possible to let the *Abstractions* create new objects without any knowledge of collaboration by asking an abstract factory to create these objects. The real instance of this abstract factory, called PAC-C3D factory, will deliver *Controls* (which are *Proxies* of their *Abstraction*) instead of *Abstractions*.

In the same way, the *Controls* must use several factories in order to create their associated *Abstractions* and *Presentations*. The PAC-C3D factory will give each *Control* one factory for *Abstraction* creation, and a list (which can be empty) of factories for *Presentations* creation, corresponding to each kind of existing *Presentation* on its node. If allowed by its distribution policy, then the *Control* will ask the *Abstraction* factory to create a real *Abstraction*. Next, the *Control* will ask each *Presentation* factory to create a *Presentation*. This is illustrated figure 11 for the creation of a PAC-C3D object on one node that is hosting two kinds of *Presentations*.

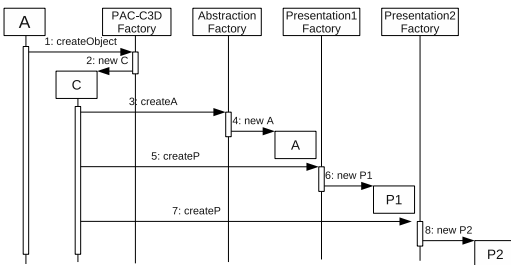

Figure 11: Creation of the PAC-C3D facets

Then, according to its distribution policy, this *Control* can send a message to the other nodes of the CVE to create also local *Controls*: each local PAC-C3D factory will allow the creation of a local *Control* with the appropriate set of local *Presentations*.

## 6 ADAPTATION TO DIFFERENT REPRESENTATIONS

As our model offers great independence between the facets of each PAC-C3D object, it makes it easy to provide several kinds of *Presentations* for a same virtual object.

First, for each distribution mode, the *Controls* can be associated to different kinds of *Presentations*, dedicated to a particular visualization of the shared virtual environment. For example, with *Controls* written in Java, on one node the *Presentation* could rely on Java3D [2] while on another node it could rely on JMonkey [4] or jReality [5]. As the implementation details of the 3D graphics API are encapsulated within the *Presentations*, for example it is also possible to use any C++ 3D graphics API without perturbing *Abstractions* and *Controls*.

To avoid code duplication, all the code relative to high-level interaction with virtual objects should be removed from the *Presentations* and written once in some *Abstractions* of PAC 3D interaction tools. But for an optimal efficiency, it is also possible to use built-in interaction and navigation metaphors that come with a 3D viewer.

Several kinds of *Presentations* can also be associated with the same *Control* in order to provide several representations of a shared virtual environment to a user. Some of these representations can also be a 2D visualization of the CVE. This can be extended to any kind of presentation, which could be non-visual, as a sound or a physical representation.

To benefit fully from “active” *Presentations* such as physics engines (for example they can react to an update because of collision detection when trying to move a 3D object), the behavior of the PAC-C3D *Controls* should be slightly adapted, otherwise the “naive” use of such engines could introduce more latency and some

small inconsistencies on other *Presentations* in the worst situation about distribution (when the physical *Presentation* is not on the same node than its associated *Abstraction* (see figure 12)). This adaptation could consist in updating first the “active” *Presentations* and taking their results into account before updating the “passive” *Presentations*.

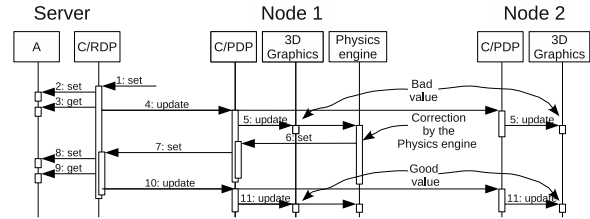

Figure 12: “Naive” use of a physics engine

## 7 PAC-C3D IMPLEMENTATION EXAMPLES

In this section we will make a short point about the current implementations of PAC-C3D, then we will illustrate this model through 3 examples, in the context of the Collaviz framework [13, 1]. The first one explains in details how PAC-C3D can help the designer of a new 3D collaborative visualizer to reuse existing interaction tools. The second one describes more generally how PAC-C3D has been used to design the IIVC concept. The third one describes how PAC-C3D allowed us to integrate a physics engine within the Collaviz framework.

### 7.1 Current implementations of PAC-C3D

The first implementation of our model is dedicated to student VR projects and has already been used for two years. This simple implementation has been made with Java3D [2] and JMonkey [4] as 3D rendering engines, and implements only the referent and proxy distribution policies, with migration capabilities. The proxy distribution policy uses Java RMI for communication with its referent, and the referent distribution policy uses Multicast facilities to communicate with its proxies *Controls*.

The second implementation is dedicated to industrial collaborative scientific visualization, it has been implemented in the context of a collaborative project called Collaviz [13, 1]. It relies on both Java3D (for desktop visualization) and jReality (for desktop and immersive visualization) as illustrated figure 1. The *Controls* can use the three distribution policies, and these distribution policies use either TCP or HTTP for communication [19]. All these distribution policies can be changed at run-time. This implementation has also been coupled to the JBullet [3] Physics Engine which appears as another *Presentation* associated to some *Controls* of the system.

### 7.2 The 2DPointer/3DRay

Here is a full example of the benefits to use our model that shows the complementarity of the PAC-C3D separation between abstraction and presentation and of the PAC-C3D collaboration through the controls. This example is the implementation of the 2DPointer/3DRay metaphor [14]: a 3D ray for 3D selection and interaction which orientation is computed so that the user always sees this 3D ray as a 2D pointer on the screen, to be used as easily as a classical 2D pointer, but to be seen as a 3D ray by the other users of the shared virtual environment.

We first implemented this 2DPointer/3DRay metaphor in our Java3D visualizer, this cursor was driven with mouse events provided by Java3D. We took care to clearly separate the behavior of the 2DPointer/3DRay (the computation of its orientation according

to its position, that has been isolated in an abstraction component) from the Java3D presentation code in charge of the Java3D mouse events and of the 3D picking for object selection. As a first result, this 2DPointer/3DRay can be driven by any other input device able to provide a position, for example a wiimote or an ART tracking device (see figure 13).

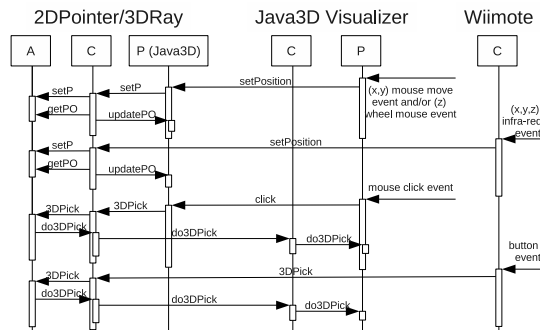

Figure 13: Driving the same abstraction with different input devices

Then, we worked with jReality to provide another 3D viewer, mainly dedicated to immersive visualization devices such as workbenches or CAVE. As this viewer was not first dedicated to desktops, we did not want to waste time to write a small presentation component able to deal with mouse events, which would be useless for immersive situations as we would use an ART tracking system for interaction. But for testing this new jReality visualization component, some work had to be done in desktop mode, and some interaction could be useful. We decided to use the 2DPointer/3DRay metaphor driven by a wiimote (see figure 14).

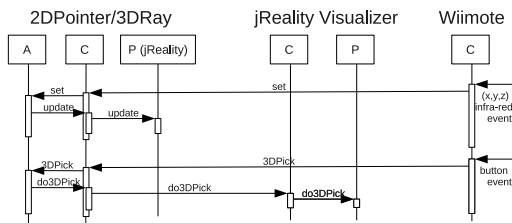

Figure 14: Visualizing an abstraction with another 3D API

Once the 2DPointer/3DRay metaphor was driven by a wiimote within our jReality visualizer, the only remaining problem was to allow this metaphor to select and manipulate 3D objects. The more natural solution was to enable a 3D picking service in jReality.

If such a picking service could not have been realized with jReality, we could also have enabled the 3D picking thanks to our Java3D visualizer. As PAC-C3D has been used to design the Collaviz framework architecture, the Collaviz system allows to share a virtual environment between several visualizers, so it is possible to instantiate a Java3D visualizer and a jReality visualizer to share a common virtual environment. The abstraction of the 2DPointer/3DRay interaction metaphor of the jReality Visualizer can be instantiated on the process of the Java3D visualizer, that owns also a control component and a Java3D presentation component for this metaphor, while the process of the jReality visualizer owns only a proxy control and a jReality presentation component for this metaphor. As illustrated figure 15, this distribution mode would allow the proxy control on the jReality side to send the picking request to the referent control on the Java3D side, which would

be able to achieve the picking thanks to the 3D picking service of the Java3D visualizer.

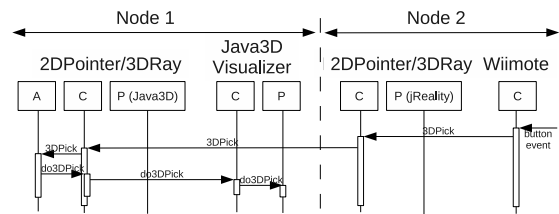

Figure 15: Delegating behavior to abstraction and other presentation

### 7.3 Other interaction and navigation tools

The whole architecture of our 3D visualizers is designed thanks to the PAC-C3D model, this enables us to provide a common architecture for navigating and interacting within 3D virtual environments that we call the Immersive Interactive Virtual Cabin (IIVC) [18]. All the operators that have been proposed for this IIVC (such as dedicated navigation modes or interaction tools) are implemented within abstraction components linked to dedicated presentation in charge of the visualization of their actions upon the virtual environment through control components.

It makes it possible to use the same input devices (for example a 2D GUI or a joystick) for navigation whatever the 3D graphics API is used for a 3D visualizer: the navigation orders are sent to the abstraction of what we call a “conveyor”, which supports several virtual objects including a virtual viewpoint, which position and orientation are changed whenever the conveyor moves in the world. These changes occur in the abstraction of the virtual viewpoint, then its control component is in charge of propagating these changes to its associated local presentation component and to its distributed controls if any.

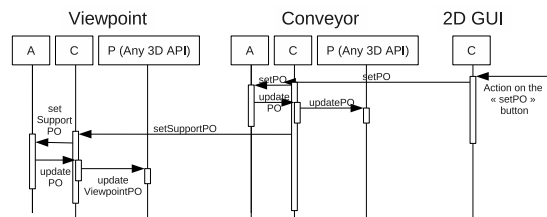

Figure 16: Delegating navigation to the abstraction of a viewpoint

Figure 16 illustrates these local exchanges with the camera of a 3D visualizer: the position and orientation changes of the conveyor are sent to the abstraction of the virtual viewpoint, which can compute its own new position and orientation before sending them to its presentation through its control component. The presentation of the virtual viewpoint can be linked to the camera of a 3D visualizer, which impacts the rendering of the 3D visualizer.

So, any particular way of navigation (for example a “travelling” along some interesting object, or an “examine” navigation mode allowing to turn around a virtual object, or a “walk” or a “fly” navigation mode allowing different kinds of exploration of a virtual environment) has only to be coded once, in the abstraction of the conveyor, to be available for any 3D visualizer, whatever the 3D graphics API used.

In the same way, a conveyor can support any 3D interaction tool (such as our 2D pointer / 3D ray, or classical 3D virtual rays, virtual hands or virtual 3D cursors), and here again these interaction tools offer the same behavior whatever the 3D graphics API used.



## 7.4 Coupling a physics engine to a virtual environment

To make collision detection possible within our 3D visualizers, we chose to integrate the JBullet Physics Engine [3] into the Collaviz framework. The most straightforward way to achieve this is to place the JBullet engine component on the central collaboration server process, in order to be able to provide the physics services (for example collision detection or mechanical constraints) in the same way to any Visualizer client. Otherwise, this JBullet component could be placed on any node of the shared virtual environment. So, for any virtual object for which we want to offer physics, we declare it as a physical object, with an additional JBullet presentation component, linked to the JBullet engine. Each move of the virtual object in the virtual environment will make its physical JBullet presentation move in the JBullet world (see figure 17), which will allow to take into account the results (collision or constraints) provided by the JBullet engine, as already presented figure 12.

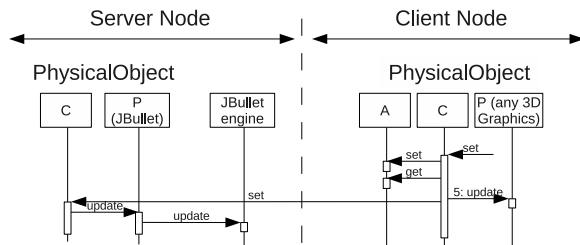

Figure 17: Maintaining consistency between Virtual and Physical worlds

Once again, this allows to offer physics for the objects of the virtual universe whatever the 3D graphics API used for the 3D Visualizer: We have implemented generic physical 3D cursors that behave exactly in the same way in our two main visualizers, based on Java3D and jReality.

## 8 CONCLUSION AND FUTURE WORK

The PAC-C3D architectural model is an explicit evolution of the PAC model dedicated to 3D collaborative virtual environments. Each shared virtual object of a CVE must be decomposed into three main kinds of components described by three interfaces. The *Abstraction* is in charge of the core data and behavior of the object, the *Presentations* are in charge of the presentation of the object to the user, and the *Control* is in charge of the consistency maintenance between *Abstraction* and *Presentations*, and between all the distributed *Controls* of the shared object.

PAC-C3D can deal with the main distribution modes encountered in CVE and it has been validated with several distribution policies, on local area networks and on wide area networks over the internet.

PAC-C3D also makes it possible to design a CVE with very small dependency on a 3D graphics API, and it makes it easy to use different 3D graphics API for different nodes involved in the same collaborative session, providing easy interoperability between 3D graphics API. It is also possible to rapidly couple other 3D engines (for example physics engines) by adding another *Presentation* (related to the engine) to PAC-C3D objects.

The next steps are to take explicitly into account “active” *Presentations* and to couple PAC-C3D objects with other kinds of engines, for example Artificial Intelligence behavior libraries that could be used in the same way as a physics engine to drive virtual objects.

## ACKNOWLEDGEMENTS

This work was partly funded by the French Research National Agency project named Collaviz (ANR-08-COSI-003-01).

## REFERENCES

- [1] The Collaviz website. <http://www.collaviz.org/>.
- [2] The Java3D website. <http://java3d.java.net/>.
- [3] The JBullet website. <http://jbullet.advel.cz/>.
- [4] The JMonkey website. <http://jmonkeyengine.org/>.
- [5] The jReality website. <http://www3.math.tu-berlin.de/jreality/>.
- [6] G. Calvary, J. Coutaz, and L. Nigay. From Single-User Architectural Design to PAC\*: a Generic Software Architecture Model for CSCW. In *Proceedings of CHI 97, ACM publ*, pages 242–249, 1997.
- [7] J. Coutaz. PAC: An Object Oriented Model for Implementing User Interfaces. *SIGCHI Bull.*, 19(2):37–41, 1987.
- [8] C. Cruz-Neira, D. J. Sandin, and T. A. DeFanti. Surround-screen projection-based virtual reality: the design and implementation of the cave. In *Proceedings of SIGGRAPH'93*, pages 135–142, New York, NY, USA, 1993. ACM.
- [9] M. Davis. Struts, an open-source MVC implementation. <http://www.ibm.com/developerworks/library/j-struts/>, february 2001.
- [10] D. Delaney, T. Ward, and S. McLoone. On consistency and network latency in distributed interactive applications: A survey – part I. *Presence: Teleoperators and Virtual Environments*, 15(2):218–234, 2006.
- [11] D. Delaney, T. Ward, and S. McLoone. On Consistency and Network Latency in Distributed Interactive Applications: A Survey – Part II. *Presence: Teleoperators and Virtual Env.*, 15(4):465–482, 2006.
- [12] P. Dewan. Architectures for Collaborative Applications. *Trends in Software, special issue on Collaborative Systems*, pages 169–193, 1999.
- [13] F. Dupont, T. Duval, C. Fleury, J. Forest, V. Gouranton, P. Lando, T. Laurent, G. Lavoué, and A. Schmutz. Collaborative Scientific Visualization: The COLLAVIZ Framework. In *JVRC Demos*, 2010.
- [14] T. Duval and C. Fleury. “An asymmetric 2D Pointer/3D Ray for 3D interaction within collaborative virtual environments”. In *Proceedings of the Web3D'09 conference*, pages 33–41, 2009.
- [15] E. Gamma, R. Helm, R. Johnson, J. Vlissides. *Design patterns: Elements of reusable Object-Oriented Software*. Addison-Wesley, 1995.
- [16] R. Eckstein. Java SE Application Design With MVC. <http://www.oracle.com/technetwork/articles/javase/mvc-136693.html>, march 2007.
- [17] C. Ellis and J. Wainer. A conceptual model of groupware. In *Proceedings of the 1994 ACM conference on Computer supported cooperative work, CSCW '94*, pages 79–88, New York, NY, USA, 1994. ACM.
- [18] C. Fleury, A. Chauffaut, T. Duval, V. Gouranton, and B. Arnaldi. A Generic Model for Embedding Users’ Physical Workspaces into Multi-Scale Collaborative Virtual Environments. In *Proc. of ICAT*, pages 1–8, 2011.
- [19] C. Fleury, T. Duval, V. Gouranton, and B. Arnaldi. A New Adaptive Data Distribution Model for Consistency Maintenance in Collaborative Virtual Environments. In *Proc. of JVRC*, pages 29–36, 2010.
- [20] C. Fleury, T. Duval, V. Gouranton, and B. Arnaldi. Architectures and Mechanisms to efficiently Maintain Consistency in Collaborative Virtual Environments. In *Proc. of the 3rd IEEE VR 2010 Workshop on Software Engineering and Architectures for Realtime Interactive Systems (SEARIS 2010)*, pages 87–94, 2010.
- [21] A. Goldberg. Information models, views, and controllers. *Dr. Dobbs’ J.*, 15:54–61, May 1990.
- [22] Y. Laurillau and L. Nigay. Clover architecture for groupware. In *Proceedings of the Conference on Computer-Supported Cooperative Work*, pages 236–245. ACM, 2002.
- [23] M. R. Macedonia and M. J. Zyda. A taxonomy for networked virtual environments. *IEEE Multimedia*, 4(1):48–56, Jan-Mar 1997.
- [24] L. Nigay and J. Coutaz. Building User Interfaces: Organizing Software Agents. In *Proceedings of Esprit'91*, pages 709–717, 1991.
- [25] M. Potel. MVP: Model-View-Presenter — The Taligent Programming Model for C++ and Java. <http://www.wildcrest.com/Potel/Portfolio/mvp.pdf>, 1996.
- [26] T. Reenskaug. The original MVC reports. <http://heim.ifi.uio.no/~trygver/2007/MVC-Originals.pdf>, 1979.
- [27] . UIMS 1992. A metamodel for the runtime architecture of an interactive system: the uims tool developers workshop. *SIGCHI Bull.*, 24(1):32–37, 1992.