

# Tutorial on Control and State Constrained Optimal Control Problems – PART I : Examples

Helmut Maurer



University of Münster

Institute of Computational and Applied Mathematics

SADCO Summer School, Imperial College London, September 5, 2011



# Pioneers and Examples

---

- Pioneers in the [Calculus of Variations and Optimal Control](#)
- Control of a [van der Pol oscillator](#): various cost functionals and constraints; regular, bang-bang and singular controls
- Time-optimal control of a [two-link robot](#)
- Time-optimal control of a [semiconductor laser](#)
- Optimal control of the [chemotherapy of HIV](#)
- Optimal production and maintenance

[Joint work with](#)

Christof Büskens, Ralf Hannemann, Jang-Ho Robert Kim, Georg Vossen



# Fermat's Principle : Light travels in minimum time



Pierre de Fermat (1608–1665)

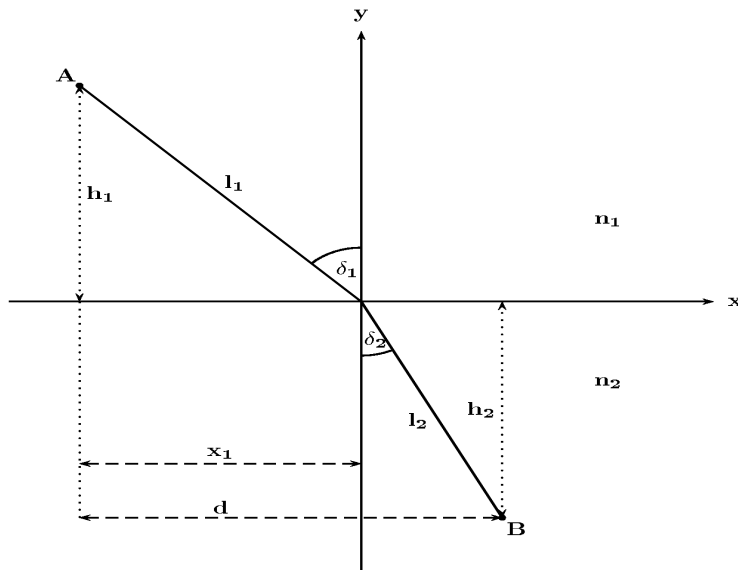

$$\frac{\sin(\delta_1)}{\sin(\delta_2)} = \frac{c_1}{c_2} = n$$

Brechungsgesetz von Snellius: Willebrord van Roijen Snell (1618)



# 1696 : Birth of the Calculus of Variations

---



Jakob Bernoulli (1655–1705)



Johann Bernoulli (1667–1748)

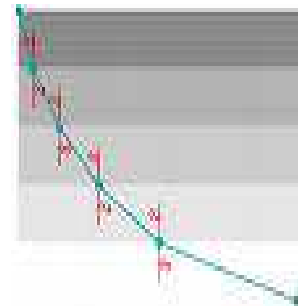

Brachystochrone: minimum time trajectories between A and B



# Necessary Optimality Conditions

---

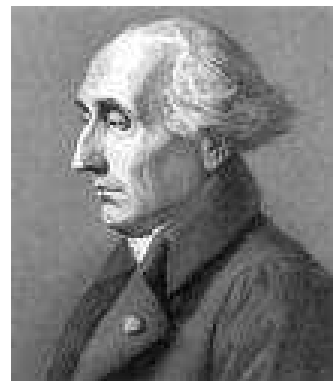

Leonhard Euler (1707–1783)

Joseph-Louis Lagrange (1736–1813)

## Calculus of Variations: Euler–Lagrange Equations



Magnus Hestenes (1906–1991)

Lev Pontryagin (1908–1988)

## Optimal Control: Maximum Principle (Pontryagin et al.)



# Formulation of optimal control problems

---

$x(t) \in \mathbf{R}^n$  : state variable,  $0 \leq t \leq t_f$

$u(t) \in \mathbf{R}^m$  : control variable, piecewise continuous in practice

$t_f > 0$  : final time, fixed or free

Determine a control function  $u \in L^\infty([0, t_f], \mathbf{R}^m)$  that

minimizes 
$$g(x(t_f)) + \int_0^{t_f} f_0(t, x(t), u(t)) dt$$

subject to 
$$\dot{x}(t) = f(t, x(t), u(t)), \quad t \in [0, t_f],$$

$$x(0) = x_0, \quad \varphi(x(t_f)) = 0,$$

control constraint 
$$u(t) \in U \subset \mathbf{R}^m \text{ (convex)} \quad \forall t \in [0, t_f],$$

state constraint 
$$s(x(t)) \leq 0 \quad \forall t \in [0, t_f], \quad (s : \mathbf{R}^n \rightarrow \mathbf{R}^k)$$

Typical control and state constraints:

$$u_{\min} \leq u(t) \leq u_{\max}, \quad x_{\min} \leq x(t) \leq x_{\max} \quad \forall t \in [0, t_f]$$



# Van der Pol oscillator: dynamics

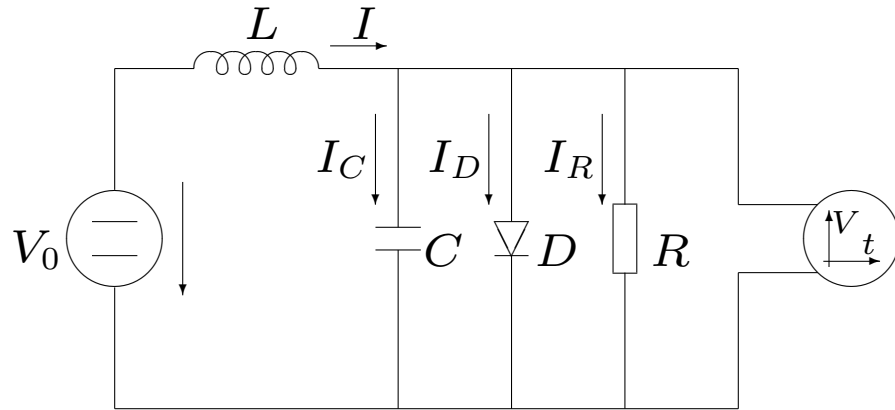

$$x_1(t) = V(t) \quad \text{voltage}$$

$$u(t) = V_0(t) \quad \text{control}$$

Dynamics without control:  $\dot{x}_1(t) = x_2(t)$  ,  $x_1(0) = 1$  ,  
 $\dot{x}_2(t) = -x_1(t) + x_2(t)(1 - x_1(t)^2)$  ,  $x_2(0) = 1$  .

state variables  $x_1$  (red),  $x_2$  (green)

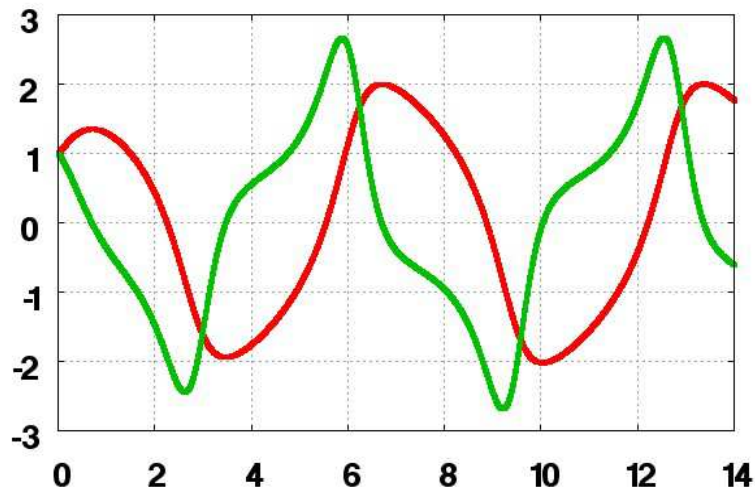

phaseportrait  $x_1 - x_2$  : limit cycle

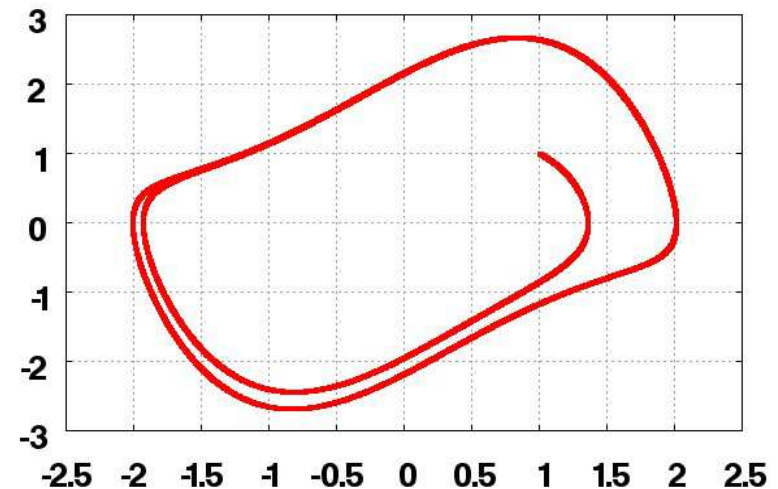



# Van der Pol oscillator: regulator control

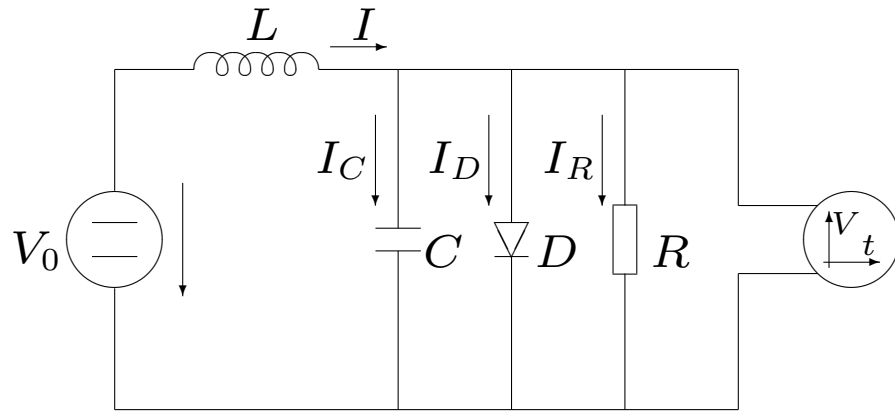

$$x_1(t) = V(t) \quad \text{voltage}$$

$$u(t) = V_0(t) \quad \text{control}$$

Minimize  $\int_0^{t_f} (x_1(t)^2 + x_2(t)^2 + u(t)^2) dt$  ( $t_f = 4$ )

subject to  $\dot{x}_1(t) = x_2(t),$   $x_1(0) = 1,$   
 $\dot{x}_2(t) = -x_1(t) + x_2(t)(1 - x_1(t)^2) + u(t),$   $x_2(0) = 1,$   
 $x_1(t_f)^2 + x_2(t_f)^2 = r^2$  ( $r = 0.2$ )

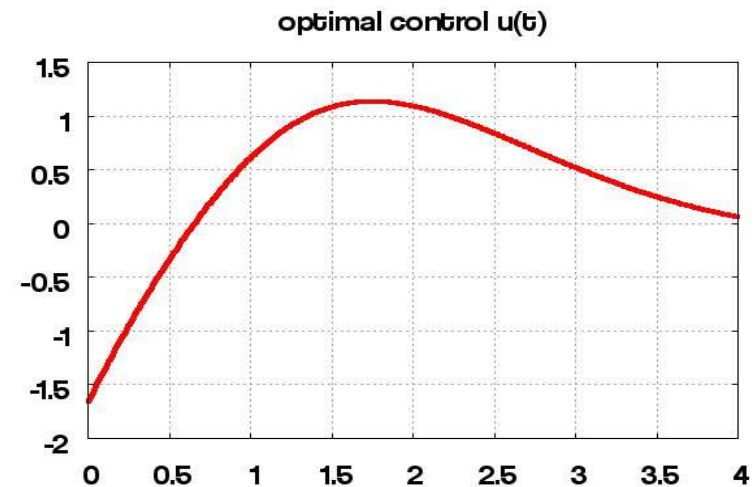
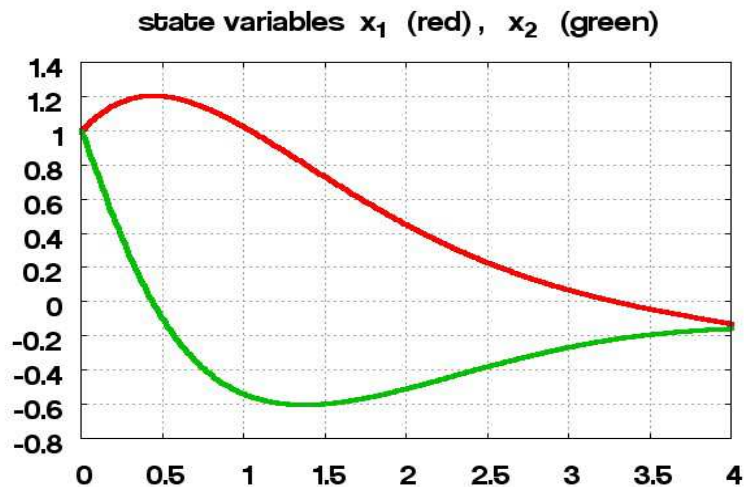





# Van der Pol oscillator: control and state constraints

Minimize  $\int_0^{t_f} (x_1(t)^2 + x_2(t)^2 + u(t)^2) dt \quad (t_f = 4)$

subject to  $\dot{x}_1(t) = x_2(t), \quad x_1(0) = 1,$   
 $\dot{x}_2(t) = -x_1(t) + x_2(t)(1 - x_1(t)^2) + u(t), \quad x_2(0) = 1,$   
 $x_1(t_f)^2 + x_2(t_f)^2 = r^2 \quad (r = 0.2)$

Control and state constraints:

$$-1 \leq u(t) \leq 1, \quad -0.4 \leq x_2(t) \quad \forall t \in [0, t_f]$$

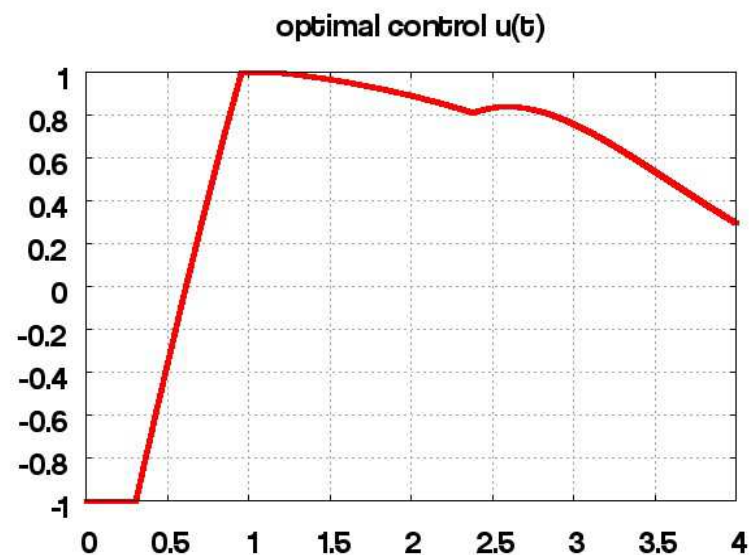
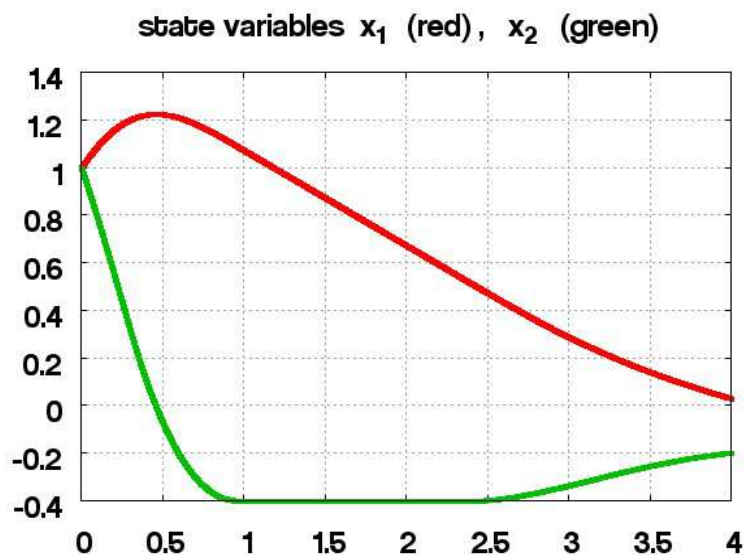



# Van der Pol oscillator: time-optimal control

Minimize the final time  $t_f$

subject to  $\dot{x}_1(t) = x_2(t), \quad x_1(0) = 1,$   
 $\dot{x}_2(t) = -x_1(t) + x_2(t)(p - x_1(t)^2) + u(t), \quad x_2(0) = 1,$   
 $x_1(t_f)^2 + x_2(t_f)^2 = r^2, \quad (r = 0.2)$   
 $-1 \leq u(t) \leq 1, \quad t \in [0, t_f].$

Perturbation  $p$  near nominal value  $p_0 = 1.0$  : discretize and optimize

Optimal bang–bang control  $u(t) = \left\{ \begin{array}{ll} -1 & , \text{ for } 0 \leq t < t_1(p) \\ 1 & , \text{ for } t_1(p) \leq t \leq t_f(p) \end{array} \right\}$

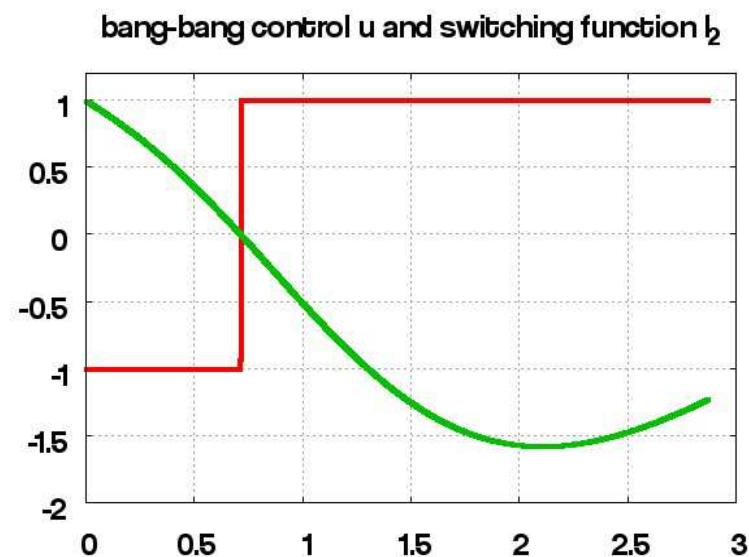
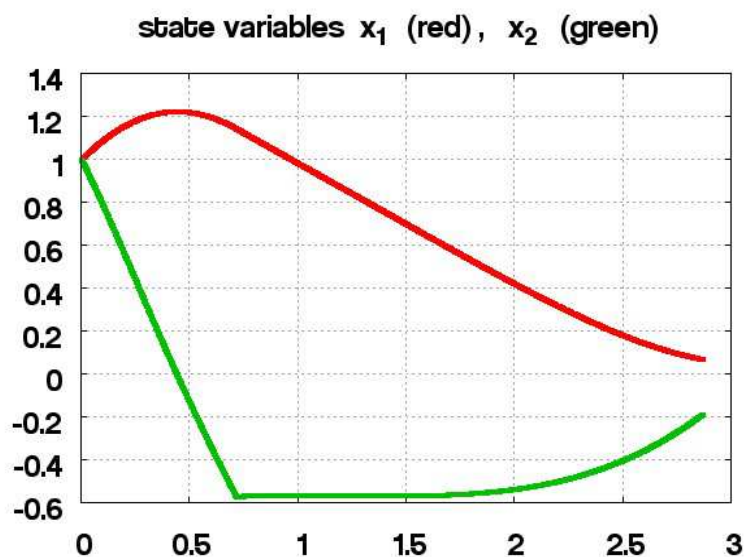



# SSC and sensitivity analysis

Optimization variables :  $z := (t_1, t_f)$

switching time  $t_1 = 0.713935566$  , final time  $t_f = 2.86419188$

Compute Jacobian of terminal conditions  $\Phi(z) = x_1(t_f)^2 + x_2(t_f)^2 = r^2$   
and Hessian of Lagrangian:

$$\Phi_z = (-0.0000264, 0.3049115), \quad \mathcal{L}_{zz} = \begin{pmatrix} 188.066 & -7.39855 \\ -7.39855 & 3.06454 \end{pmatrix}$$

SSC hold ! Sensitivity derivatives exist (code NUDOCSS, C. Büskens)

$$\frac{dt_1}{dp} = -0.344220, \quad \frac{dt_f}{dp} = 1.395480$$

Real-time control:  $t_i(p) \approx t_i^a(p) = t_i(p_0) + \frac{dt_i}{dp}(p_0)(p - p_0)$ ,  $i = 1, 2$ .

$$u(t, p) = \left\{ \begin{array}{ll} -1 & , \text{ for } 0 \leq t < t_1^a(p) \\ 1 & , \text{ for } t_1^a(p) \leq t \leq t_f^a(p) \end{array} \right\}$$



# Van der Pol oscillator: singular control

$$\begin{aligned} \text{Minimize} \quad & J(x, u) = \frac{1}{2} \int_0^{t_f} (x_1^2 + x_2^2) dt, \quad t_f = 4, \\ \text{subject to} \quad & \dot{x}_1 = x_2, \quad x_1(0) = 0, \\ & \dot{x}_2 = -x_1 + x_2(p - x_1^2) + u, \quad x_2(0) = 1, \\ & -1 \leq u(t) \leq 1. \end{aligned}$$

Hamiltonian

$$H(x, \lambda, u) = \frac{1}{2}(x_1^2 + x_2^2) + \lambda_1 x_2 + \lambda_2(-x_1 + x_2(p - x_1^2) + u)$$

$$\begin{aligned} \text{Adjoint ODEs : } \quad & \dot{\lambda}_1 = -H_{x_1} = -x_1 + \lambda_2(1 + 2x_1x_2), \quad \lambda_1(t_f) = 0, \\ & \dot{\lambda}_2 = -H_{x_2} = -x_2 - \lambda_1 - \lambda_2(p - x_1^2), \quad \lambda_2(t_f) = 0. \end{aligned}$$

Switching function:  $\sigma = H_u = \lambda_2$

Singular feedback control of order 1 : equations  $\sigma = \dot{\sigma} = \ddot{\sigma} \equiv 0$  imply

$$u = u_{\text{sing}}(x, p) = 2x_1 - x_2(p - x_1^2)$$



# Van der Pol oscillator: singular control for $p_0 = 1$

Optimal control is bang–bang–singular

$$u(t) = \left\{ \begin{array}{ll} -1 & \text{for } 0 \leq t < t_1 = 1.3667 \\ 1 & \text{for } t_1 \leq t < t_2 = 2.4601 \\ 2x_1 - x_2(1 - x_1^2) & \text{for } t_2 \leq t \leq t_f = 4 \end{array} \right\}$$

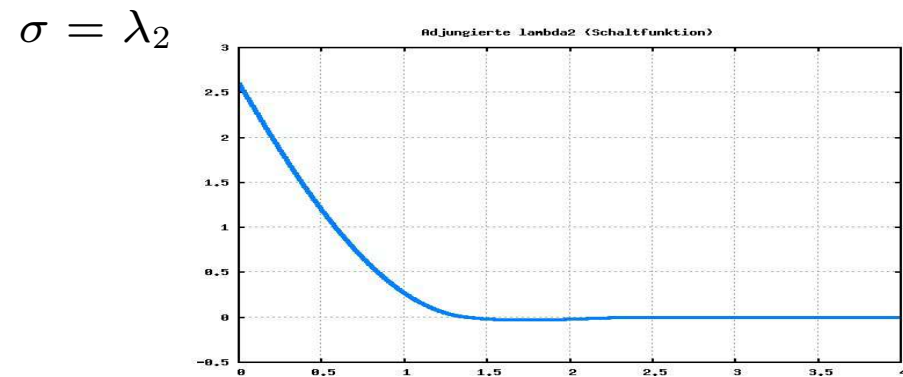
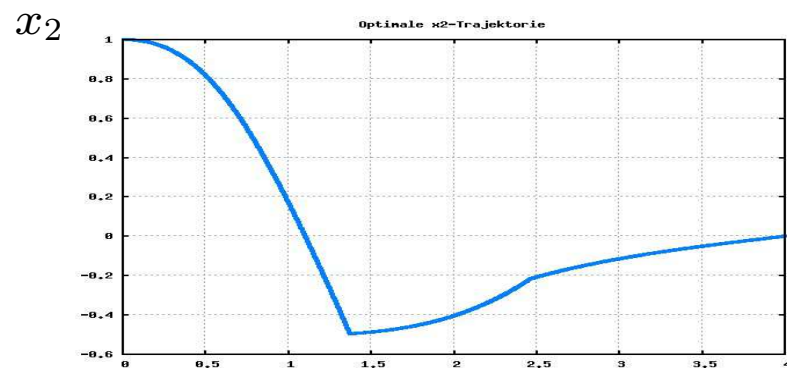
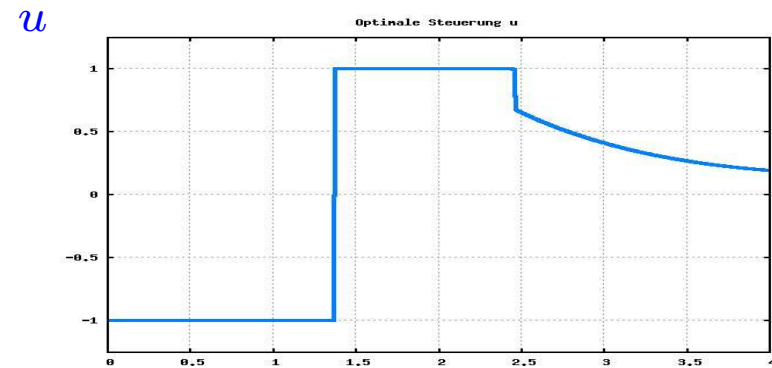
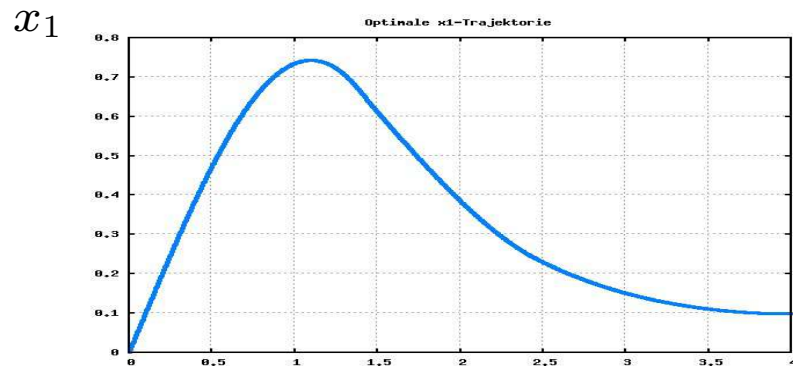



# SSC for switching times and sensitivity analysis

Optimize with respect to  $z = (t_1, t_2)$

Hessian of the Lagrangian

$$\mathcal{L}_{zz} = \begin{pmatrix} 215.4 & -10.54 \\ -10.54 & 0.5665 \end{pmatrix} \text{ is positive definite.}$$

**Problem:** check sufficient conditions for the control problem, synthesis ?

**Sensitivity analysis and real time control:**

$$\frac{dz}{dp}(p_0) = -(\mathcal{L}_{zz})^{-1} \mathcal{L}_{zp} = \begin{pmatrix} 0.2831 \\ 2.2555 \end{pmatrix}, \quad t_i^a(p) := t_i(p_0) + \frac{dt_i}{dp}(p_0)(p - p_0), \quad i = 1, 2.$$

$$u(t, p) = \left\{ \begin{array}{ll} -1 & \text{for } 0 \leq t < t_1^a(p) \\ 1 & \text{for } t_1^a(p) \leq t < t_2^a(p) \\ 2x_1 - x_2(p - x_1^2) & \text{for } t_2^a(p) \leq t \leq t_f = 4 \end{array} \right\}$$



# Time-optimal control of a two-link robot

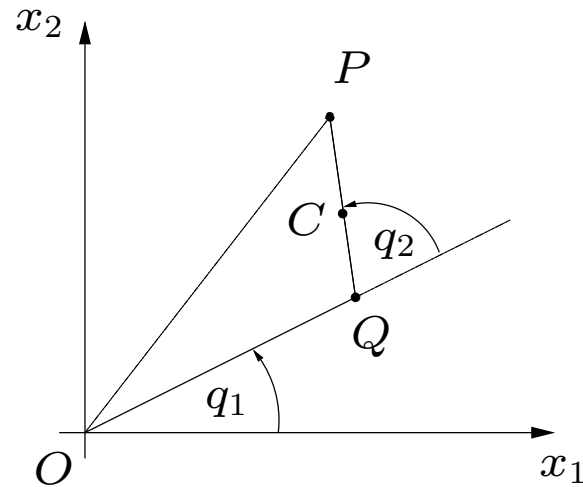

Two-link robot

## ODE system

$$\dot{q}_1 = \omega_1$$

$$\dot{q}_2 = \omega_2 - \omega_1$$

$$\dot{\omega}_1 = \frac{1}{\Delta}(AI_{22} - BI_{12} \cos q_2)$$

$$\dot{\omega}_2 = \frac{1}{\Delta}(BI_{11} - AI_{12} \cos q_2)$$

## Abbreviations

$$I_{11} = I_1 + (m_2 + M)L_1^2$$

$$I_{12} = m_2LL_1 + ML_1L_2$$

$$I_{22} = I_2 + I_3 + ML_2^2$$

$$A = I_{12}\omega_2^2 \sin q_2 + u_1 - u_2$$

$$B = -I_{12}\omega_1^2 \sin q_2 + u_2$$

$$\Delta = I_{11}I_{22} - I_{12}^2 \cos^2 q_2$$



# Time-optimal control of a two-link robot

## Boundary conditions

$$\begin{aligned} q_1(0) &= 0, & \sqrt{(x_1(t_f) - x_1(0))^2 + (x_2(t_f) - x_2(0))^2} &= r, \\ q_2(0) &= 0, & q_2(t_f) &= 0, \\ \omega_1(0) &= 0, & \omega_1(t_f) &= 0, \\ \omega_2(0) &= 0, & \omega_2(t_f) &= 0, \end{aligned}$$

where  $(x_1(t), x_2(t))$  are the Cartesian coordinates of the point  $P$ :

$$\begin{aligned} x_1(t) &= L_1 \cos q_1(t) + L_2 \cos(q_1(t) + q_2(t)), \\ x_2(t) &= L_1 \sin q_1(t) + L_2 \sin(q_1(t) + q_2(t)). \end{aligned}$$

**Control bounds:**  $|u_1(t)| \leq 1, \quad |u_2(t)| \leq 1, \quad t \in [0, t_f].$

**Minimize the final time  $t_f$ : Hamilton function**

$$\begin{aligned} H &= \lambda_1 \omega_1 + \lambda_2 (\omega_2 - \omega_1) + \frac{\lambda_3}{\Delta} (A(u_1, u_2) I_{22} - B(u_2) I_{12} \cos q_2) \\ &\quad + \frac{\lambda_4}{\Delta} (B(u_2) I_{11} - A(u_1, u_2) I_{12} \cos q_2). \end{aligned}$$





# Time-optimal control of a two-link robot

---

## Switching functions

$$\sigma_1(t) = H_{u_1}(t) = \frac{1}{\Delta} (\lambda_3 I_{22} - \lambda_4 I_{12} \cos q_2)$$

$$\sigma_2(t) = H_{u_2}(t) = \frac{1}{\Delta} (\lambda_3 (-I_{22} - I_{12} \cos q_2) + \lambda_4 (I_{11} + I_{12} \cos q_2))$$

## Optimal bang-bang control

$$u(t) = (u_1(t), u_2(t)) = \left\{ \begin{array}{ll} (-1, 1) & \text{for } 0 \leq t \leq t_1 \\ (-1, -1) & \text{for } t_1 \leq t \leq t_2 \\ (1, -1) & \text{for } t_2 \leq t \leq t_3 \\ (1, 1) & \text{for } t_3 \leq t \leq t_4 \\ (-1, 1) & \text{for } t_4 \leq t \leq t_f \end{array} \right\}$$



# Optimal solution

## Numerical values

$$L_1 = L_2 = 1, \quad L = 0.5, \quad m_1 = m_2 = M = 1, \quad I_1 = I_2 = \frac{1}{3}, \quad r = 3$$

Switching times and final time (code NUDOCCCS, Ch. Büskens)

$$t_1 = 0.5461742, \quad t_2 = 1.7596815, \quad t_3 = 2.7983470, \\ t_4 = 3.7043862, \quad t_f = 3.8894093.$$

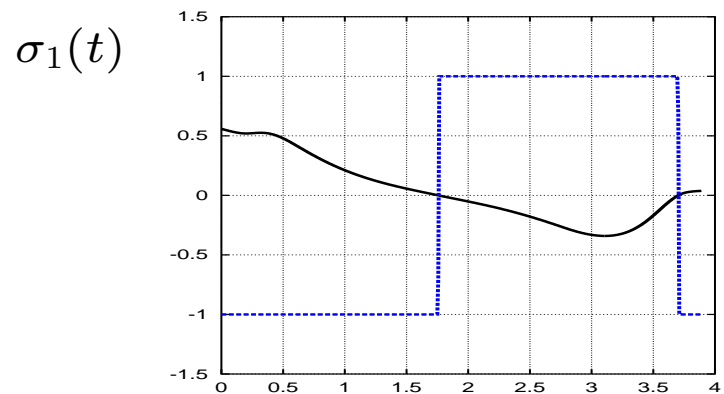

$u_1(t)$

$\sigma_2(t)$

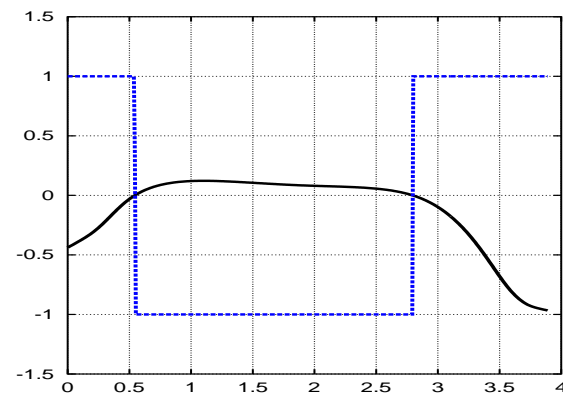

$u_2(t)$



## Second order sufficient conditions

---

Jacobian for terminal conditions :  $4 \times 5$  matrix

$$\Phi_z(z) = \begin{pmatrix} -10.8575 & -12.7462 & -5.88332 & -1.14995 & 0 \\ 0.199280 & -2.71051 & -1.45055 & -1.91476 & -4.83871 \\ -0.622556 & 3.31422 & 2.31545 & 2.94349 & 6.19355 \\ 9.36085 & 3.03934 & 0.484459 & 0.0405811 & 0 \end{pmatrix}$$

Hessian of the Lagrangian :  $5 \times 5$  matrix

$$\mathcal{L}_{zz}(z, \rho) = \begin{pmatrix} 71.1424 & 90.7613 & 42.1301 & 8.49889 & -0.0518216 \\ 90.7613 & 112.544 & 51.3129 & 10.7691 & 0.149854 \\ 42.1301 & 51.3129 & 23.9633 & 5.12403 & 0.138604 \\ 8.49889 & 10.7691 & 5.12403 & 1.49988 & 0.170781 \\ -0.0518216 & 0.149854 & 0.138604 & 0.170781 & 0.297359 \end{pmatrix}$$

Projected Hessian  $N^* \mathcal{L}_{zz}(z, \rho) N \approx 0.326929 > 0$



# Sensitivity analysis and real-time control

---

Sensitivity parameter:  $p = M$  (load)

Sensitivity derivatives for  $p_0 = 1$

$$\frac{dt_1}{dp} = 0.0817022, \quad \frac{dt_2}{dp} = 0.3060921, \quad \frac{dt_3}{dp} = 0.7115999,$$
$$\frac{dt_4}{dp} = 0.7310003, \quad \frac{dt_f}{dp} = 0.8498167.$$

Real-time control

$$u(t) = u_k \quad \text{or} \quad u(t) = u_k(x(t)), \quad t_{k-1}(p) \leq t \leq t_k(p)$$

Real-time approximation

$$t_k(p) \approx t_k(p_0) + \frac{dt_k}{dp}(p_0)(p - p_0)$$



# Time-optimal control of a semiconductor laser

Dokhane, Lippi: “Minimizing the transition time for a semiconductor laser with homogeneous transverse profile,” IEE Proc.-Optoelectron. **149**, 1 (2002).

Kim, Lippi, Maurer: “Minimizing the transition time in lasers by optimal control methods. Single mode semiconductor laser with homogeneous transverse profile”, Physica D **191**, 238–260 (2004).

$S(t)$  : photon density;  $N(t)$  : carrier density;  $I(t)$  : current (control)

$$\dot{S} = \frac{dS}{dt} = -\frac{S}{\tau_p} + \Gamma G(N, S)S + \beta BN(N + P_0)$$

$$\dot{N} = \frac{dN}{dt} = \frac{I(t)}{q} - R(N) - \Gamma G(N, S)S$$

$$G(N, S) = G_p(N - N_{tr})(1 - \epsilon S) \quad (\text{optical gain})$$

$$R(N) = AN + BN(N + P_0) + CN(N + P_0)^2 \quad (\text{recombination})$$

Initial and terminal conditions (stationary points):

$$\begin{aligned} S(0) &= S_0, & N(0) &= N_0 & (\text{for } I(t) \equiv 20.5 \text{ mA}) \\ S(t_f) &= S_f, & N(t_f) &= N_f & (\text{for } I(t) \equiv 42.5 \text{ mA}) \end{aligned}$$



# Laser: time-optimal bang-bang control

Minimize the final time  $t_f$  subject to the control bounds

$$I_{\min} \leq I(t) \leq I_{\max} \quad \text{for} \quad 0 \leq t \leq t_f$$

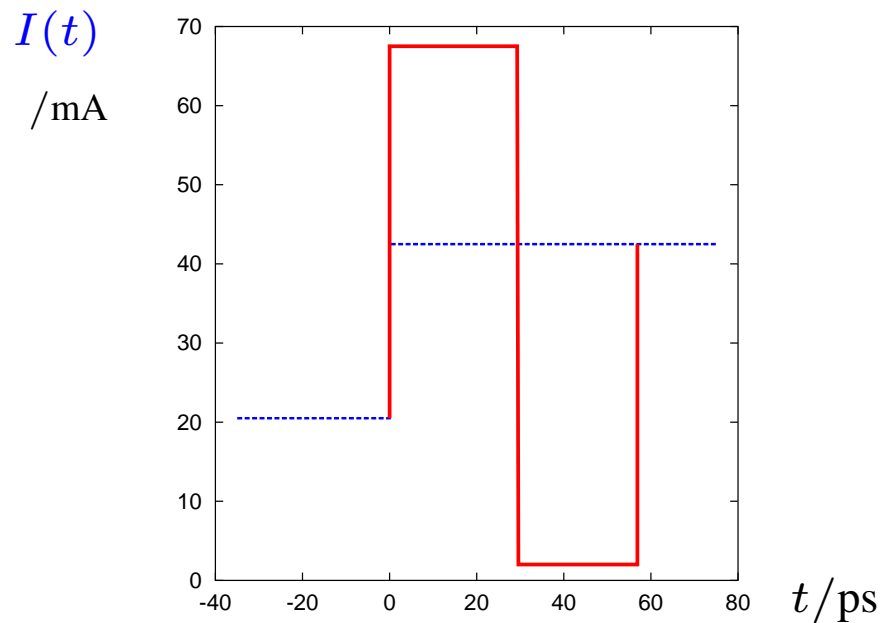

time-optimal bang-bang control

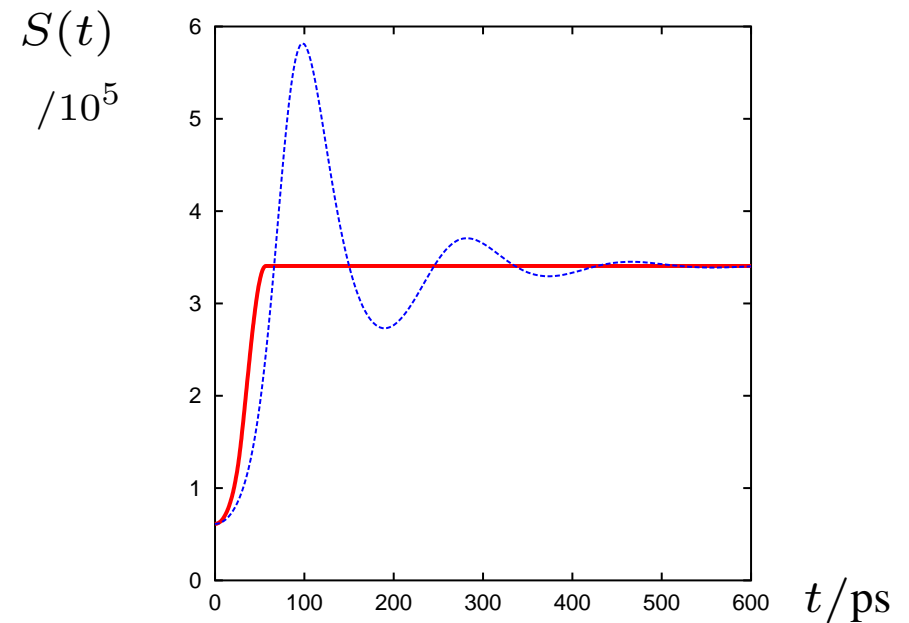

uncontrolled versus controlled



# Time-optimal bang-bang control

Time-optimal control is bang-bang:

$$I(t) = \left\{ \begin{array}{ll} I_{\max} & , \quad 0 \leq t < t_1, \\ I_{\min} & , \quad t_1 \leq t \leq t_f. \end{array} \right\}, \quad t_1 = 29.523 \text{ ps}, \quad t_f = 56.894 \text{ ps}$$

Switching function and strict bang-bang property:

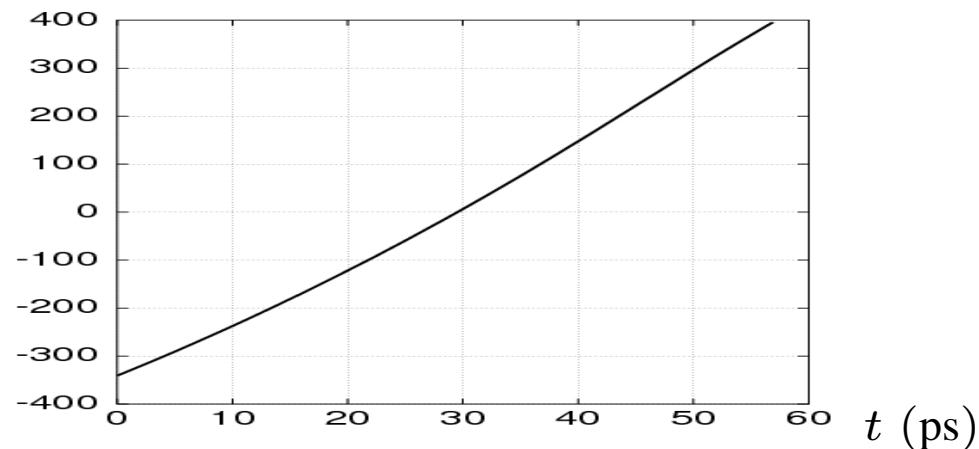

$$\sigma(t) = \lambda_N(t), \quad \sigma(t_1) = 0, \quad \dot{\sigma}(t_1) \neq 0$$



# sufficient conditions, sensitivity analysis, switch-on-off

Jacobian of terminal conditions is regular:

$$\Phi_z = \begin{pmatrix} 0.199855 & 0 \\ -1.5556 \cdot 10^{-4} & -2.52779 \cdot 10^{-3} \end{pmatrix}$$

First order sufficient conditions hold ! Sensitivity derivatives

$$p = I_{\max} : dt_1/dp = -0.55486, \quad dt_2/dp = 0.22419,$$

$$p = I_{\min} : dt_1/dp = -0.24017, \quad dt_2/dp = 0.57532.$$

Laser: simultaneous switch-on and switch-off:  $S(t_2) = S_f, N(t_2) = N_f$

$$I(t) = \left\{ \begin{array}{ll} I_{\max} & , \text{ for } 0 \leq t < t_1 \\ I_{\min} & , \text{ for } t_1 \leq t \leq t_2 \\ \text{---} & , \text{ for } t_2 < t < t_3 \\ I_{\min} & , \text{ for } t_2 < t < t_3 \\ I_{\max} & , \text{ for } t_3 \leq t \leq t_f \end{array} \right\}$$

PROBLEM: arclengths are not synchronized:  $t_1 \neq t_3 - t_2$  and  $t_2 - t_1 \neq t_f - t_3$

OPTIMIZE with respect to  $I_{\max}, I_{\min}$  and  $I_0, I_{\infty}$





# Optimal control of the chemotherapy of HIV

D. KIRSCHNER, S. LENHART, S. SERBIN, *Optimal control of the chemotherapy of HIV*, J. Mathematical Biology **35**, 775–792 (1996).

- $T(t)$  : concentration of uninfected  $CD4^+$  T cells,
- $T^*(t)$  : concentration of latently infected  $CD4^+$  T cells,
- $T^{**}(t)$  : concentration of actively infected  $CD4^+$  T cells,
- $V(t)$  : concentration of free infectious virus particles,
- $u(t)$  : **control**, rate of chemotherapy,  $0 \leq u(t) \leq 1$  ,  
 $u(t) = 1$  : **maximal** chemotherapy;  $u(t) = 0$  : **no** chemotherapy

**Dynamic model** for  $0 \leq t \leq t_f$ :

$$\frac{dT}{dt} = \frac{s}{1+V} - \mu_T T + rT \left( 1 - \frac{T + T^* + T^{**}}{T_{\max}} \right) - k_1 VT,$$

$$\frac{dT^*}{dt} = k_1 VT - \mu_T T^* - k_2 T^*, \quad \frac{dT^{**}}{dt} = k_2 T^* - \mu_b T^{**},$$

$$\frac{dV}{dt} = (1 - u(t)) N \mu_b T^{**} - k_1 VT - \mu_V V,$$



# Chemotherapy of HIV: parameters

Dynamic modeling and parameter fitting by Perelson et al.

---

Parameters and constants		Values
$\mu_T$	: death rate of uninfected $CD4^+$ T cell population	$0.02 \text{ d}^{-1}$
$\mu_{T^*}$	: death rate of latently infected $CD4^+$ T cell population	$0.02 \text{ d}^{-1}$
$\mu_b$	: death rate of actively infected $CD4^+$ T cell population	$0.24 \text{ d}^{-1}$
$\mu_V$	: death rate of free virus	$2.4 \text{ d}^{-1}$
$k_1$	: rate $CD4^+$ T cells becomes infected by free virus	$2.4 \times 10^{-5} \text{ mm}^3 \text{ d}^{-1}$
$k_2$	: rate $T^*$ cells convert to actively infected	$3 \times 10^{-3} \text{ mm}^3 \text{ d}^{-1}$
$r$	: rate of growth for the $CD4^+$ T cell population	$0.03 \text{ d}^{-1}$
$N$	: number of free virus produced by $T^{**}$ cells	1200
$T_{\max}$	: maximum $CD4^+$ T cell population level	$1.5 \times 10^3 \text{ mm}^{-3}$
$s$	: source term for uninfected $CD4^+$ T cells, where $s$ is the parameter in the source term	$10 \text{ d}^{-1} \text{ mm}^{-3}$ $s/(1 + V)$

---



# Chemotherapy of HIV : $L^2$ and $L^1$ functionals

---

- Minimize  $L^2$ -functional

$$F(x, u) = \int_0^{t_f} (-T(t) + Bu(t)^2) dt \quad (B = 50)$$

- Minimize  $L^2$ -functional: maximize terminal value  $T(t_f)$

$$F(x, u) = -t_f \cdot T(t_f) + \int_0^{t_f} Bu(t)^2 dt \quad (B = 50)$$

- Minimize  $L^1$ -functional

$$F(x, u) = \int_0^{t_f} (-T(t) + Bu(t)) dt \quad (B = 35)$$

- Minimize  $L^1$ -functional: maximize terminal value  $T(t_f)$

$$F(x, u) = -t_f \cdot T(t_f) + \int_0^{t_f} Bu(t) dt \quad (B = 35)$$



# Chemotherapy of HIV: $L^2$ functional

$$\text{Minimize } F(x, u) = \int_0^{t_f} (-T(t) + Bu(t)^2) dt, \quad B = 50$$

Begin of treatment after 800 days : initial conditions

$$T(0) = 982.8, \quad T^*(0) = 0.05155, \quad T^{**}(0) = 6.175 \cdot 10^{-4}, \quad V(0) = 0.07306,$$

Begin of treatment after 1000 days : initial conditions

$$T(0) = 904.1, \quad T^*(0) = 0.3447, \quad T^{**}(0) = 41.67 \cdot 10^{-4}, \quad V(0) = 0.4939,$$

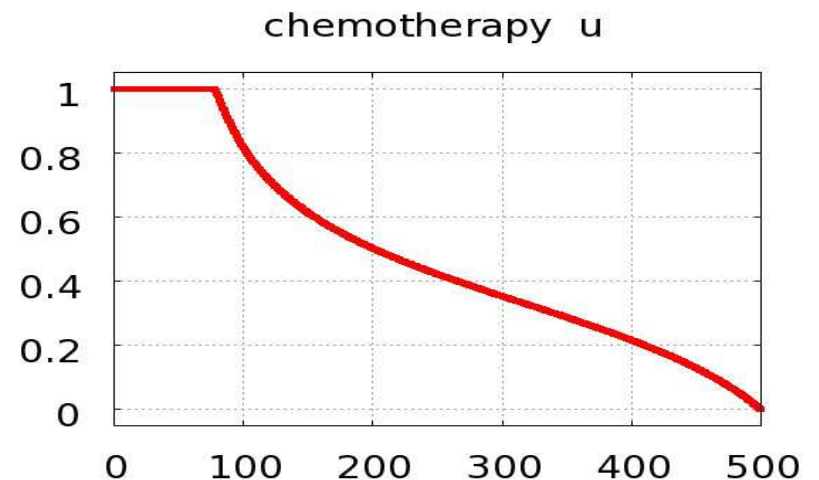
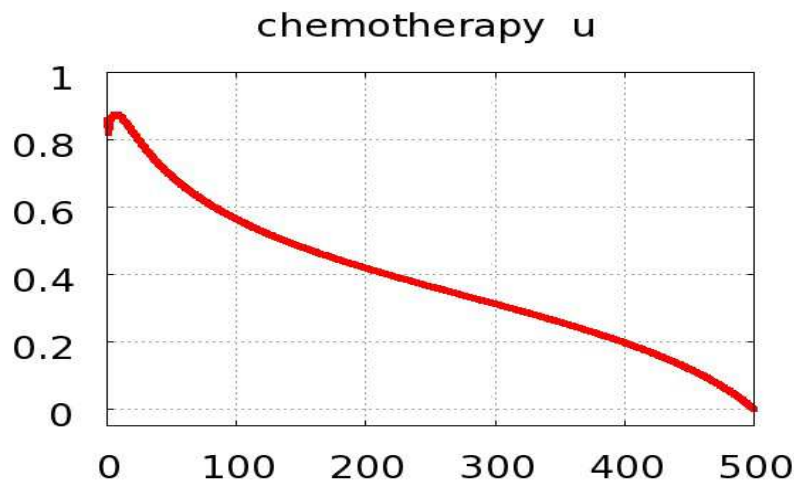



# Chemotherapy of HIV: $L^2$ functional

Begin of treatment after 1000 days :

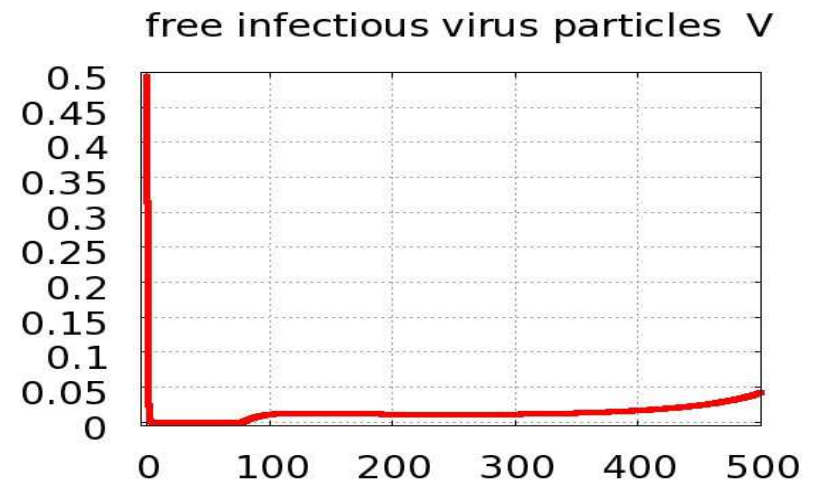
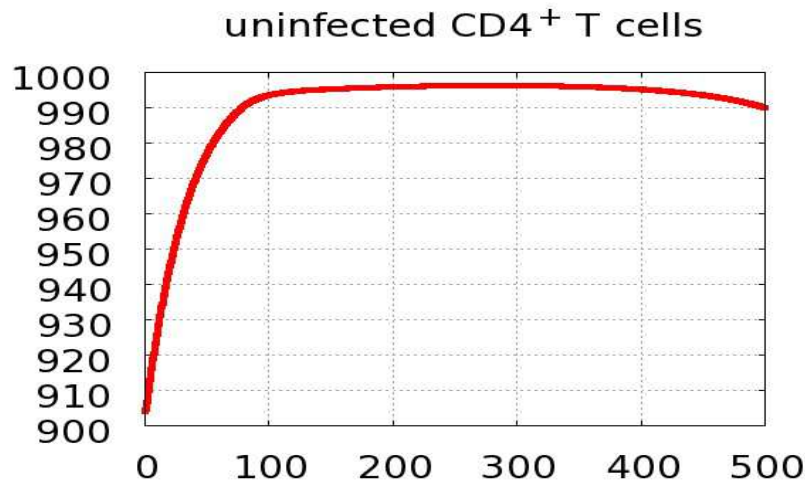

Compute adjoint variables and verify **sufficient conditions** (Ralf Hannemann).

**Legendre condition holds and matrix Riccati equation has a solution.**

(Malanowski, Maurer, Pickenhain, Zeidan)

**Sensitivity analysis** and computation of **sensitivity derivatives**.



# HIV: $L^1$ functional, bang-bang control

$$\text{Minimize } F(x, u) = \int_0^{t_f} (-T(t) + 35u(t)) dt$$

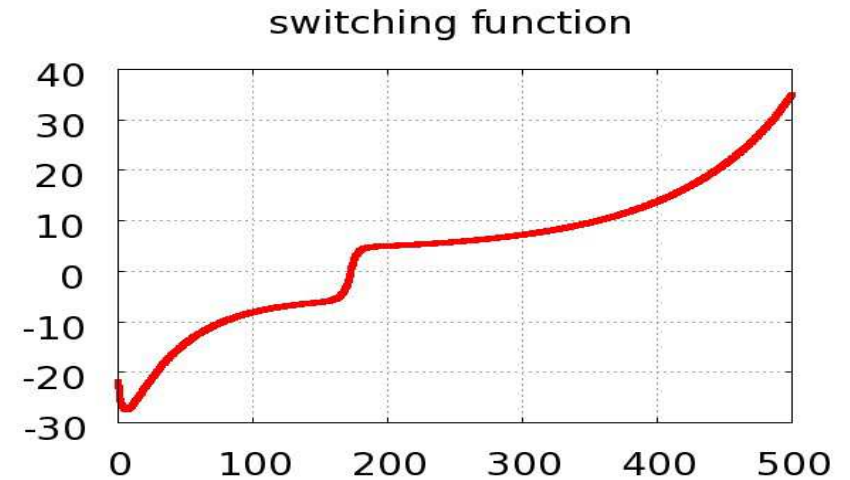
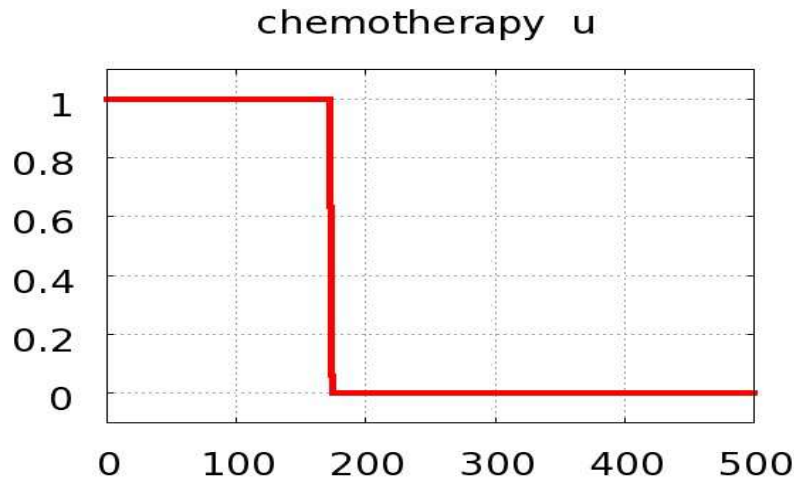

Treatment after **800 days**: optimal control and switching function.

Optimal control is bang–bang and satisfies SSC :

$$u(t) = \left\{ \begin{array}{ll} 1 & \text{for } 0 \leq t < t_1 = 173.2 \\ 0 & \text{for } t_1 \leq t < t_f = 500 \end{array} \right\}, \quad \dot{\sigma}(t_1) > 0, \quad \frac{\partial^2 F}{\partial t_1^2} = 1.14 > 0.$$



# HIV: $L^1$ functional, bang-bang control

$T(t)$

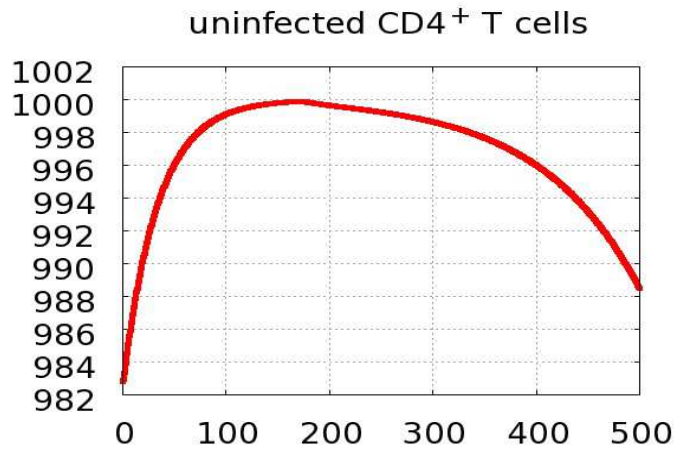

$T^*(t)$

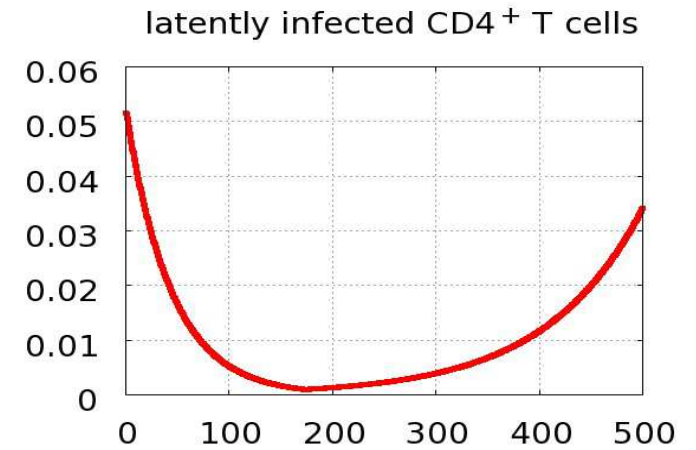

$T^{**}(t)$

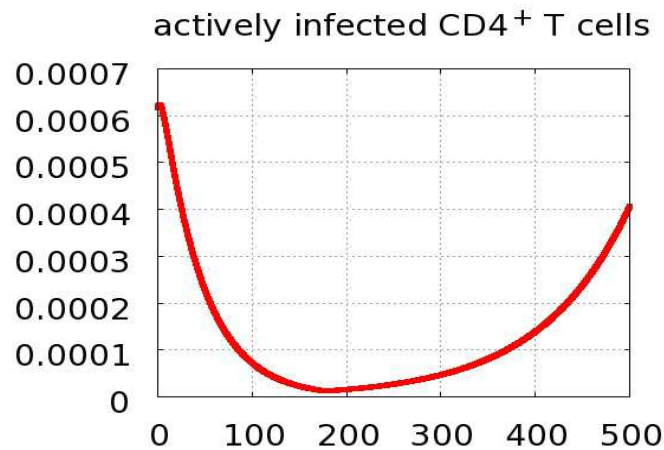

$V(t)$

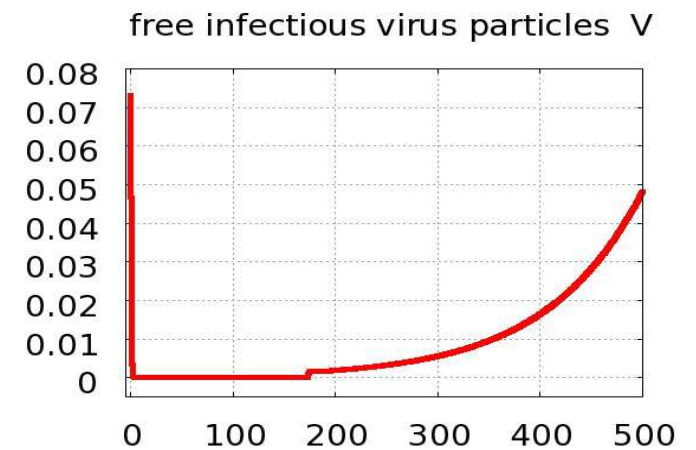

state variables  $T, T^*, T^{**}, V$



# Chemotherapy of HIV: $L^1$ functional, $\max T(t_f)$

$$\text{Minimize } F(x, u) = -t_f \cdot T(t_f) + \int_0^{t_f} 35u(t) dt$$

The optimal control is bang–bang but follows a **reverse strategy** !

$u(t)$

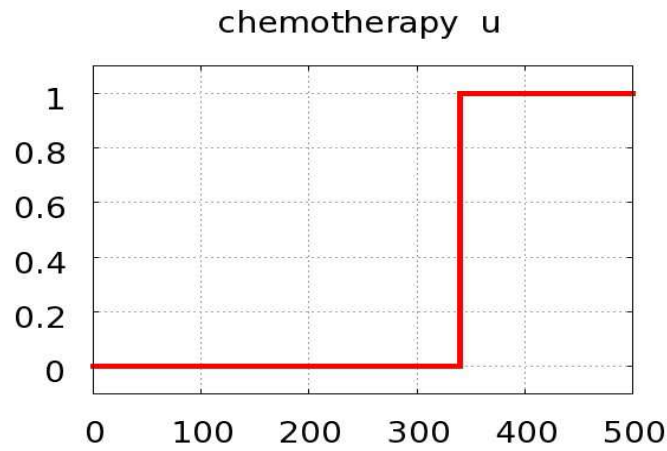

$\sigma(t)$

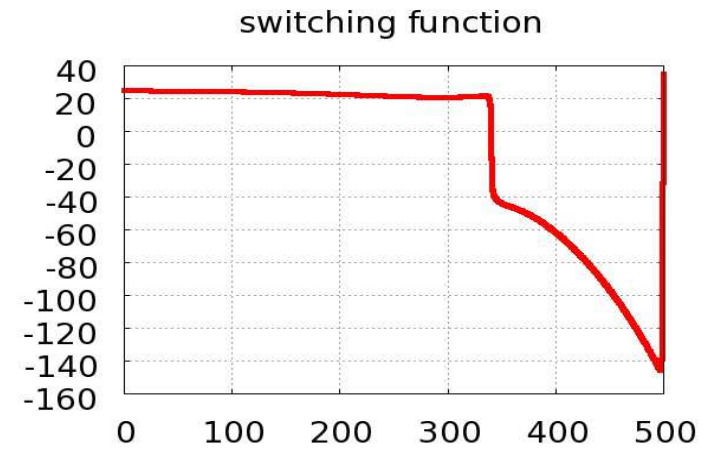

$T(t)$

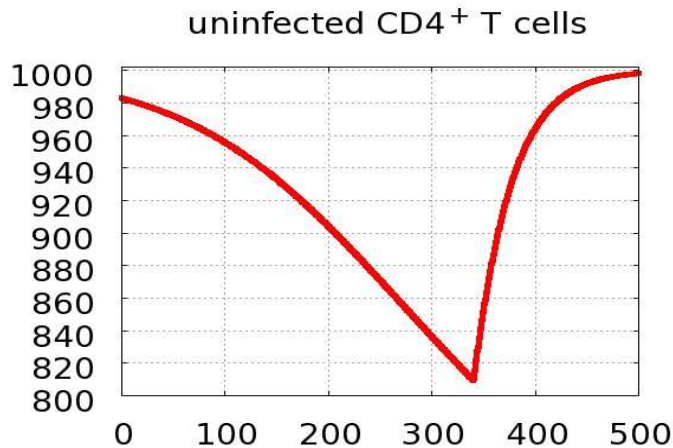

$T^*(t)$

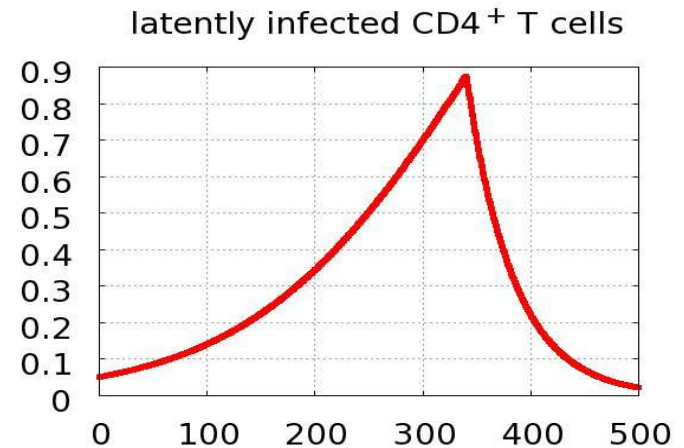





# Optimal Production and Maintenance

---

D. I. CHO, P.L. ABAD AND M. PARLAR,  
*Optimal Production and Maintenance Decisions when a System Experiences Age-Dependent Deterioration*, Optimal Control Appl. Meth. **14**, 153–167 (1993)

## State and control variables:

- $x(t)$  : inventory level at time  $t \in [0, t_f]$ , final time  $t_f$  is fixed,
- $y(t)$  : proportion of ‘good’ units of end items produced:  
process performance,
- $u(t)$  : scheduled production rate (**control**),
- $m(t)$  : preventive maintenance rate to reduce the proportion  
of defective units produced (**control**),
- $\alpha(t)$  : obsolescence rate of the process performance in the  
absence of maintenance, non-decreasing in time,
- $s(t)$  : demand rate,
- $\rho = 0.1$  : discount rate,



# Production and Maintenance: $L^2$ - and $L^1$ -Functional

State equations:

$$\begin{aligned}\dot{x}(t) &= y(t)u(t) - s(t), & x(0) &= x_0, & x(t_f) &= 0, \\ \dot{y}(t) &= -\alpha(t)y(t) + (1 - y(t))m(t), & y(0) &= y_0.\end{aligned}$$

Control constraints :  $0 \leq u(t) \leq U, \quad 0 \leq m(t) \leq M, \quad 0 \leq t \leq t_f$

State constraint :  $h(y(t)) := y(t) - y_{\min} \geq 0$

Data :  $s(t) = 4, \quad \alpha(t) = 2, \quad x_0 = 3, \quad y_0 = 1, \quad U = 3, \quad M = 4$

Maximize  $F(x, y, u, m) = 10y(t_f)e^{-\rho t_f} +$   
$$+ \int_0^{t_f} e^{-\rho t} [8s(t) - x(t) - (ru^2(t) + qu(t)) - 2.5m(t)] dt .$$

$L^2$ -functional in  $u$  for  $r = 2, q = 0$  : mixed type of control (Osmolovskii/M.)

$L^1$ -functional in  $u$  for  $r = 0, q = 4$  : this talk



# $L^2$ -Functional: bang-singular maintenance

$L^2$  functional in  $u$  : initial values  $x_0 = 3$ ,  $y_0 = 1$ , final time  $t_f = 1$

$u(t)$

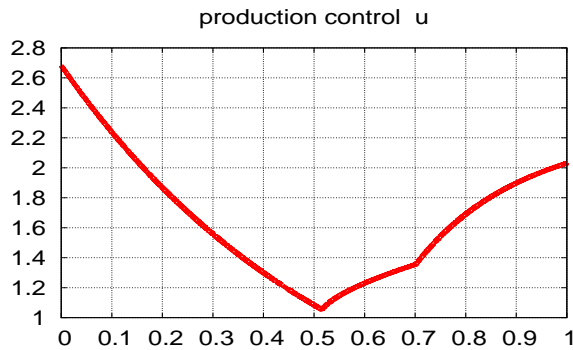

$m(t)$

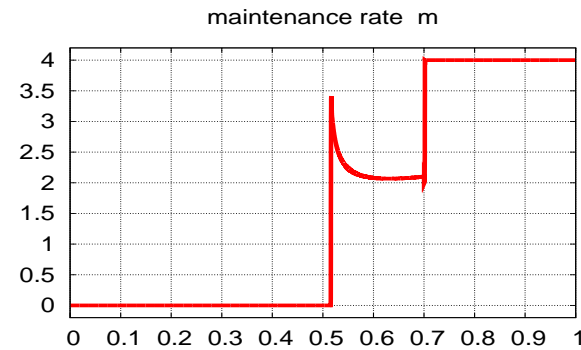

$x(t)$

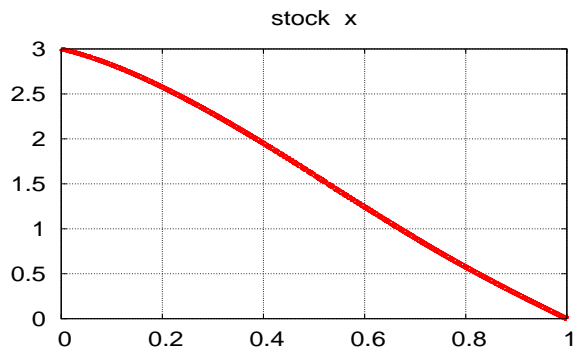

$y(t)$

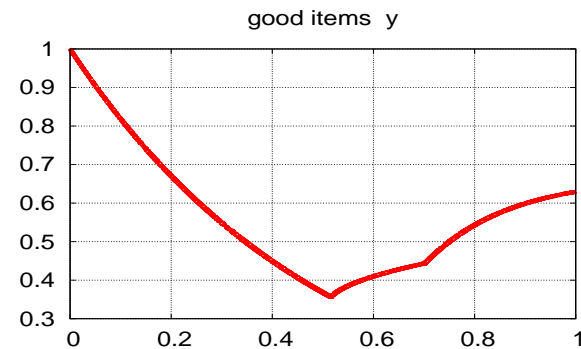

Sufficient conditions are not available !



# $L^2$ -Functional: bang-singular maintenance

$L^2$  functional in  $u$  : initial values  $x_0 = 3$ ,  $y_0 = 1$ , final time  $t_f = 0.9$

$u(t)$

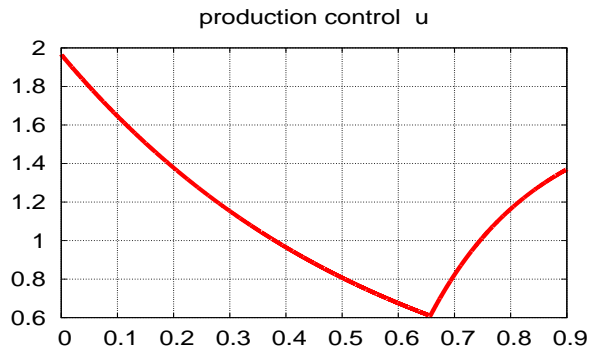

$m(t)$

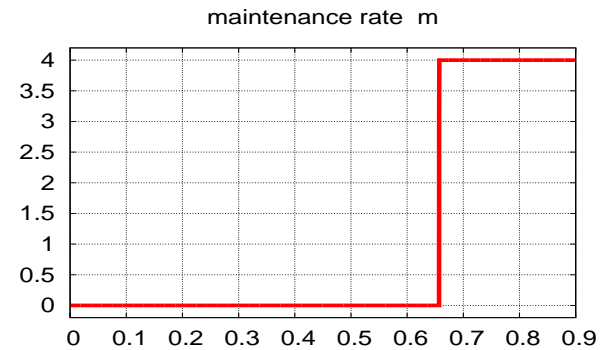

$x(t)$

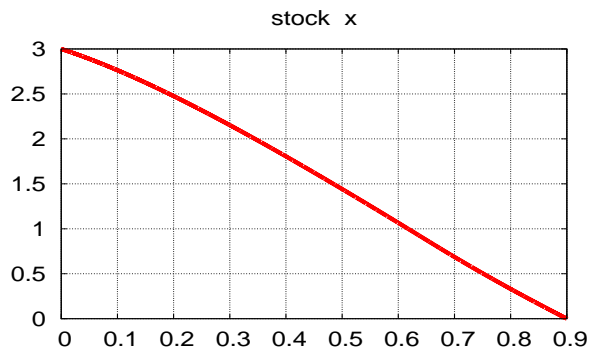

$y(t)$

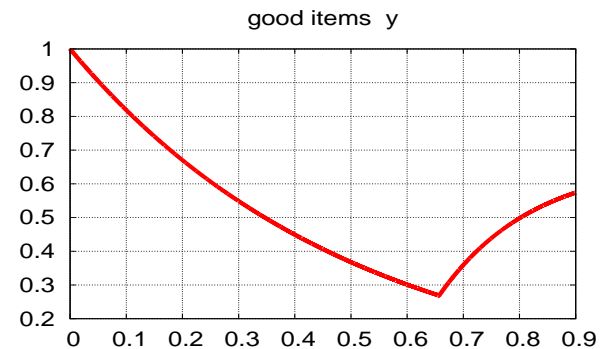

Second-order sufficient conditions hold: Osmolovskii, Maurer



# $L^1$ -Functional: necessary conditions

Current value Hamiltonian for **maximum principle**: adjoint variables  $\lambda_x, \lambda_y$

$$H(x, y, u, m, \lambda_x, \lambda_y) = (8s - x - 4u - 2.5m) \\ + \lambda_x(yu - s) + \lambda_y(-\alpha y + (1 - y)m),$$

Adjoint equations and transversality conditions:

$$\dot{\lambda}_x = \rho\lambda_x - \frac{\partial H}{\partial x} = \rho\lambda_x + h, \quad \lambda_x(t_f) = \nu, \\ \dot{\lambda}_y = \rho\lambda_y - \frac{\partial H}{\partial y} = \lambda_y(\rho + \alpha + m) - \lambda_x u, \quad \lambda_y(t_f) = 10.$$

Switching functions  $\sigma^u(t) = \lambda_x(t)y(t) - 4$  ,  $\sigma^m(t) = \lambda_y(t)(1 - y(t)) - 2.5$

$$u(t) = \left\{ \begin{array}{ll} 0 & , \text{ if } \sigma^u(t) < 0, \\ U = 3 & , \text{ if } \sigma^u(t) > 0 \\ \text{singular} & , \text{ if } \sigma^u(t) \equiv 0 \end{array} \right\}, \quad m(t) = \left\{ \begin{array}{ll} 0 & , \text{ if } \sigma^m(t) < 0, \\ M = 4 & , \text{ if } \sigma^m(t) > 0 \\ \text{singular} & , \text{ if } \sigma^m(t) \equiv 0 \end{array} \right\}$$



# $t_f = 1$ : bang–bang controls $u$ and $m$

Solution for  $t_f = 1$ : controls  $u$  and  $m$  are bang–bang

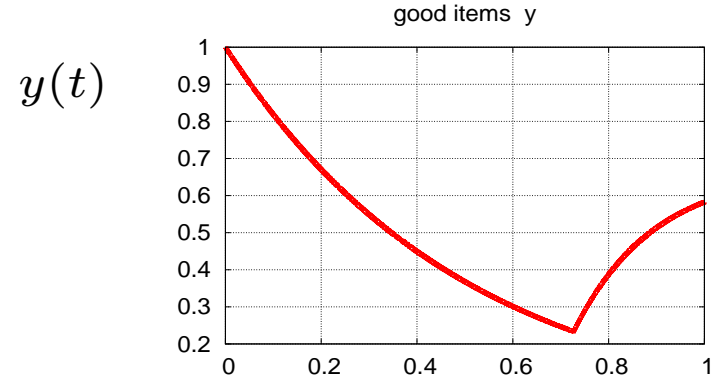
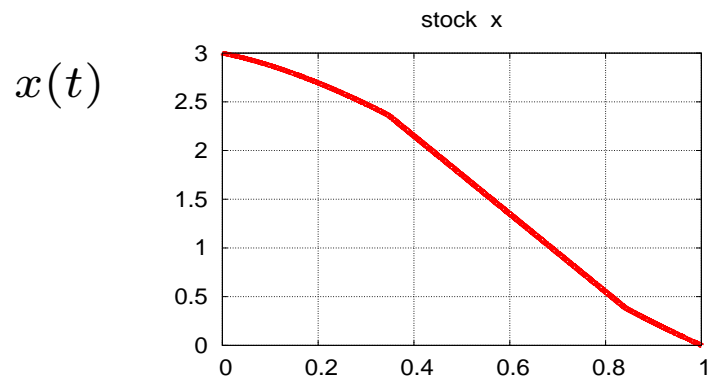
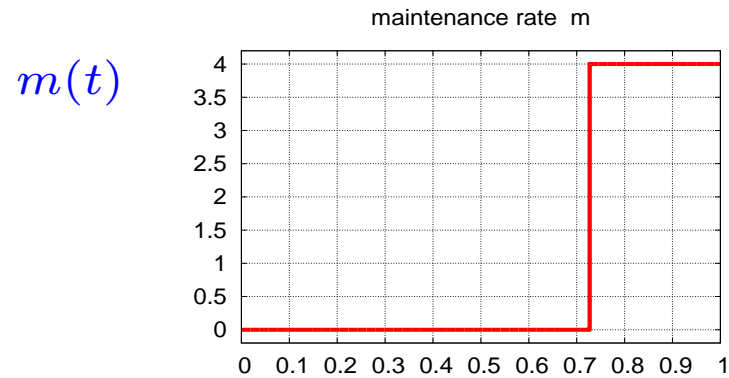
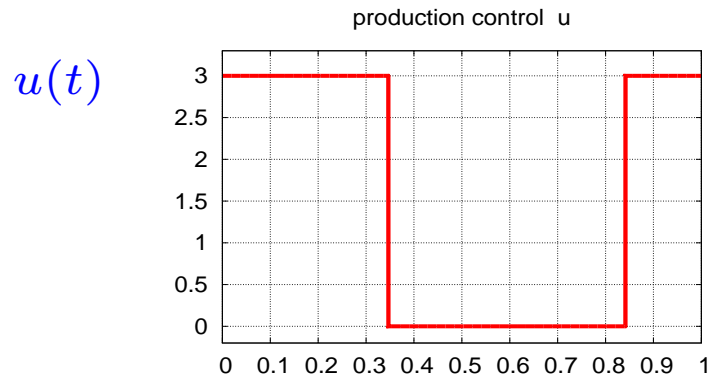

Switching times:  $t_1 = 0.3465$ ,  $t_2 = 0.7270$ ,  $t_3 = 0.8415$

Optimization problem: optimize  $z := (t_1, t_2, t_3)$ , boundary condition  $x(t_f, z) = 0$ .

SSC hold :  $D_{zz}^2 \mathcal{L}$  is positive definite on the tangent space of the constraint.



# $t_f = 1$ : SSC for bang–bang controls $u$ and $m$

$u(t)$

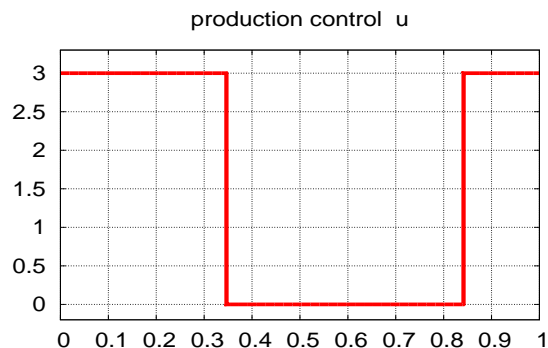

$m(t)$

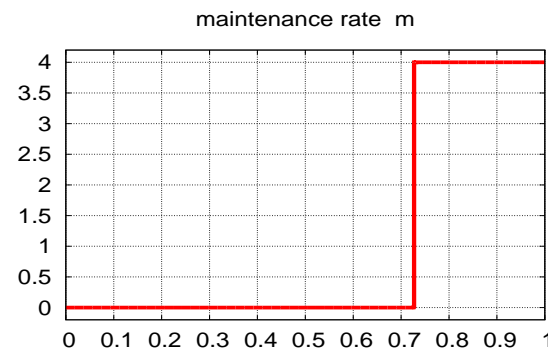

$\sigma^u(t)$

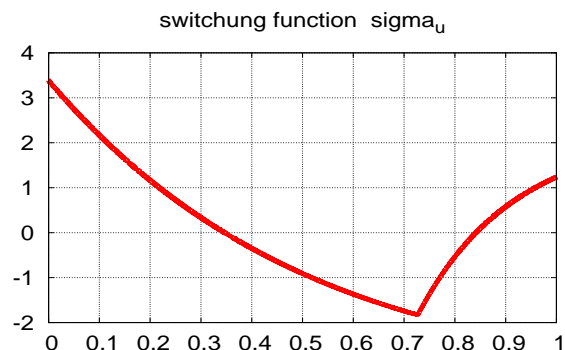

$\sigma^m(t)$

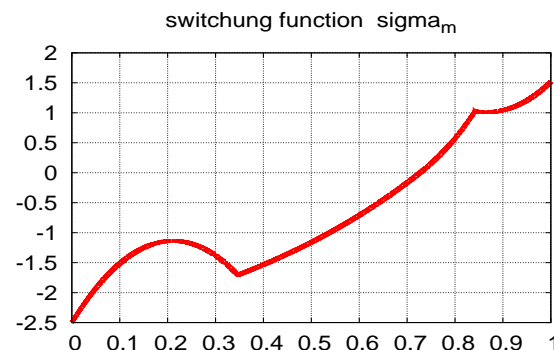

Strict bang-bang property holds:  $\dot{\sigma}^u(t_1) < 0$ ,  $\dot{\sigma}^m(t_2) > 0$ ,  $\dot{\sigma}^u(t_3) > 0$ .

$\Rightarrow$  SSC hold for the control problem:

Agrachev, Stefani, Zezza (SICON 2002),

Osmolovskii (1988), Osmolovskii, Maurer (2003–09)



# state constraint $y(t) \geq 0.4$

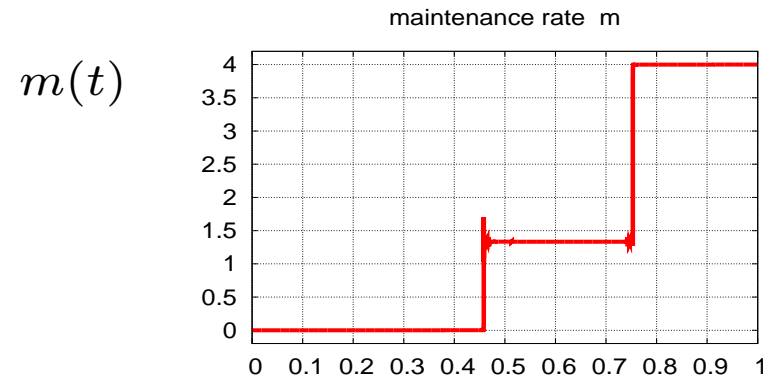
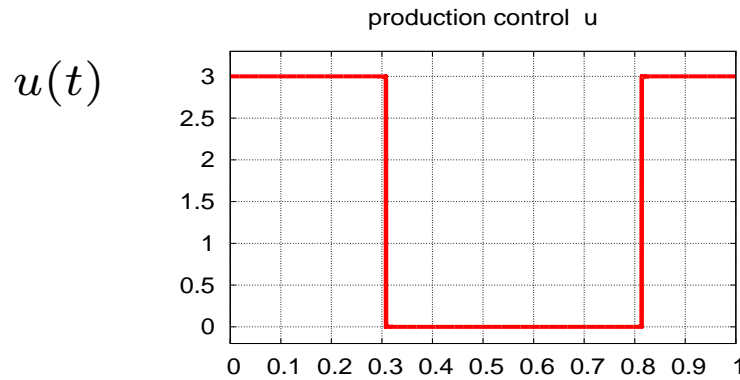
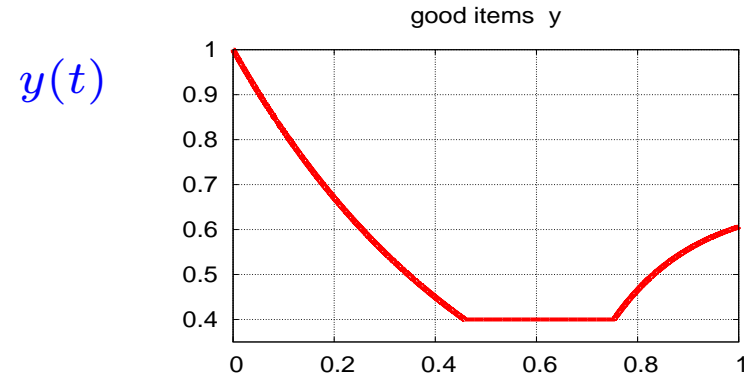
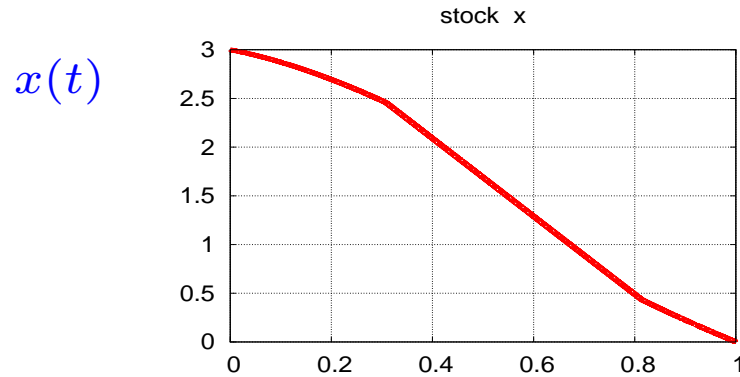

Switching times:  $t_1 = 0.3080$ ,  $t_2 = 0.4581$ ,  $t_3 = 0.7531$ ,  $t_4 = 0.8137$

Boundary arc  $[t_2, t_3]$ : boundary control  $m_b \equiv \alpha y_{\min}/(1 - y_{\min})$  (feedback)

Optimization problem: optimize  $z := (t_1, t_2, t_3, t_4)$

Boundary and entry conditions:  $x(t_f, z) = 0$ ,  $y(t_2, z) = 0.4$

SSC hold:  $D_{zz}^2 \mathcal{L}$  is positive definite on the tangent space of the constraints.