



HAL
open science

Modeling and Dimensioning Ground Heat Exchangers Principles: Influence of the soil's thermal proprieties

Francois Lavoué, Bernard Tourancheau

► **To cite this version:**

Francois Lavoué, Bernard Tourancheau. Modeling and Dimensioning Ground Heat Exchangers Principles: Influence of the soil's thermal proprieties. International Building Performance Simulation Association, IBPSA France, 2010, Moret sur Loing, France. inria-00566079

HAL Id: inria-00566079

<https://inria.hal.science/inria-00566079v1>

Submitted on 15 Feb 2011

HAL is a multi-disciplinary open access archive for the deposit and dissemination of scientific research documents, whether they are published or not. The documents may come from teaching and research institutions in France or abroad, or from public or private research centers.

L'archive ouverte pluridisciplinaire **HAL**, est destinée au dépôt et à la diffusion de documents scientifiques de niveau recherche, publiés ou non, émanant des établissements d'enseignement et de recherche français ou étrangers, des laboratoires publics ou privés.

***Eléments pour la Modélisation et le Dimensionnement des Sondes
Géothermiques de Faible Profondeur :
Influence des propriétés thermiques des sols***
**Modeling and Dimensioning Ground Heat Exchangers Principles:
Influence of the soil's thermal proprieties**

François Lavoué^{a,b,*}, Bernard Tourancheau^c

^aDépartement de Géologie, ENS-Lyon, 46 allée d'Italie, F-69364 Lyon Cedex 07

^bLGIT, Maison des Géosciences, 1381 rue de la Piscine, BP53, F-38041 Grenoble Cedex 9

^cUniversité Lyon 1, INRIA and CITI, INSA-Lyon, bât. C. Chappe, F-69621

*Corresponding author: Francois.Lavoue@ens-lyon.org

RÉSUMÉ. Dans un contexte de crise énergétique et de réchauffement climatique, le chauffage des bâtiments grâce à l'énergie solaire stockée dans le sol est un principe intéressant. De plus, les sondes géothermiques utilisées pour extraire la chaleur du sol permettent aussi de l'y réinjecter, et donc de refroidir les bâtiments grâce à l'inertie thermique du sol. Cet article présente nos réflexions sur la modélisation et le dimensionnement des échangeurs thermiques en faible profondeur couplés à des pompes à chaleur (PAC géothermique). Après une présentation de la physique sous-jacente aux échangeurs thermiques et des méthodes de résolution analytiques et numériques, nous soulignons l'importance des valeurs des paramètres thermiques du sol utilisées par les outils numériques pour simuler les PAC géothermiques. Nous illustrons cette question à partir de résultats de simulation dynamique TRNSYS : ceux-ci sont fortement influencés par les valeurs de conductivité thermique du sol. Enfin, nous présentons un état de l'art des mesures de ces paramètres thermiques *in situ* et suggérons quelques méthodes géophysiques pour les déterminer indirectement, parmi lesquelles le géoradar, l'induction électromagnétique et la tomographie électrique. La forte empreinte de la teneur en eau sur la thermique des sols permettrait en effet d'estimer leurs caractéristiques thermiques via des mesures de conductivité électrique ou de permittivité diélectrique, elles aussi reliées à la teneur en eau du milieu.

MOTS-CLÉS: Echangeurs thermiques, Etude de sensibilité paramétrique, TRNSYS, Pompe à chaleur (PAC) géothermique

ABSTRACT. In the context of energy crisis and global warming, heating buildings with the solar energy stored in the soil represents a very interesting alternative. Moreover, cooling buildings can also use the soil damping capacity. This paper presents our reflexion about the modeling and dimensioning of the ground heat exchanger part of ground-coupled heat pumps (GCHP). After a physical overview of the ground heat exchanger, we extract from analytical solutions practical consequences of the soil damping behavior and limits that provide guidelines for the dimensioning. We then question the default values of the numerical tools thermal parameters used for the simulation of GCHP. We illustrate this issue through a TRNSYS dynamic simulation of GCHP, demonstrating that soil's thermal parameters have a strong impact on the results. Finally, we give some perspectives for the determination of soil's characteristics *in situ*, but indirectly, thanks to geophysical prospection methods as ground penetrating radar, electromagnetic induction, or electrical resistivity tomography.

KEYWORDS: Ground Heat Exchangers (GHE), Sensitivity Study, TRNSYS, Ground-Coupled Heat Pump (GCHP)

Nomenclature:		Indices:	
T	temperature (K)	s	soil
q	heat flux (W)	a	ambient air
R	thermal resistance (K.m.W^{-1})	f	fluid in the tubes
C_p	heat capacity ($\text{J.K}^{-1}.\text{kg}^{-1}$)	b	borehole wall
λ	thermal conductivity ($\text{W.m}^{-1}.\text{K}^{-1}$)	i	input
ρ	density (kg.m^{-3})	o	output
α	thermal diffusivity ($\text{m}^2.\text{s}^{-1}$)	av	mean value
h	convective coefficient ($\text{W.K}^{-1}.\text{m}^{-2}$)	Abbreviations:	
ω	temperature-wave frequency (Hz)	COP	Coefficient Of Performance
θ	bulk water content (m^3/m^3)	LST	Line-Source Theory
σ	electrical conductivity (S/m)		

INTRODUCTION

In the present energetic context, where fossil energies must face global warming, it appears as a necessity to find new, and renewable, energy sources. In order to heat buildings, an alternative could be the solar energy stored in the soil. The recent decades have seen the rapid development of ground-coupled heat pumps (GCHP) in the USA and Europe (Lund et al. (2003)). A GCHP is a conventional heat pump (HP) coupled with a ground heat exchanger (GHE): tubes buried in the soil in which circulates a calorific fluid. Using a stable temperature source at depth, a GCHP is more efficient than a conventional air-to-air HP and is more independent from climatic conditions. This efficiency must therefore be paid by expensive tube burying costs. Hence depth is often not a choice and a design study is necessary. As a consequence, many researchers deal with modeling and simulation of GHE for their dimensioning.

As reported by Lamarche and Beauchamp (2007), the modeling of GHE involves two heat transfer problems. The first transfer is a partly convective heat flux between the fluid in the tubes and the wall of the borehole. It is mostly solved analytically and we find examples of this analytical resolution in Hollmuller (2002) and Hellström (1991). Hollmuller gives a nice demonstration for the temperature evolution inside the tubes, from which he deduces simple dimensioning rules. Hellström lays the basis for the line-source theory (LST) which is used in most GHE simulations. The second transfer is considered by most researchers to be a pure conductive heat flux between the borehole and the soil. This conduction phenomenon is mostly numerically treated. Here we study the influence of tubes' length for heating or cooling a particular building using a TRNSYS type developed by Giardina (1995).

Finally, we aim to focus on the role of soil's thermal proprieties (section 4). Indeed, these parameters have a great effect on the efficiency of GHE: we intend to show this with TRNSYS simulations. Here we discuss several methods for measuring these proprieties *in situ* or in laboratory. Then we investigate a relation between electrical and thermal resistivity empirically, shown by Singh et al. (2001), which seems promising.

1. PHYSICAL PRINCIPLES OF HEAT EXTRACTION THROUGH GROUND-COUPLED HEAT PUMP

1.1 THE HEAT PUMP: A THERMODYNAMICAL MACHINE

A heat pump is a thermodynamical machine. Provided an electrical work W , it extracts a heat amount Q_1 from a cold source (whose temperature we note T_1) and transfers a heat amount Q_2 to a hot source, whose temperature is T_2 (see figure i). In the case of GCHP, the cold source is the fluid at the tubes output (*i.e.* $T_1 = T_{fo}$) and the hot source is the fluid to be warmed: distributed air, warming fluid, or domestic hot water. The coefficient of performance (COP) of such a machine is defined by:

$$COP = \frac{Q_{\text{useful}}}{W} = \frac{Q_2}{W} = -\frac{Q_2}{Q_1 + Q_2} = \frac{T_2}{T_2 - T_{fo}} \quad (1)$$

If we consider the machine as ideal (Carnot's machine), we can express its COP with the 1st and the 2nd thermodynamical principles like in equation (1). This *ideal* COP is seen as the theoretical maximal

COP of real machines. As a consequence, we must get a temperature T_{fo} as large as possible at the tubes output to improve the COP. It means that the heat exchange between soil and tubes must be optimized. We can notice that cooling is free and doesn't require any electrical work in summer.

1.2 HEAT CONDUCTION AND THERMAL INERTIA IN THE GROUND

In a homogeneous soil, heat transfers obey to

$$\partial_t T = \alpha \nabla^2 T \quad (2)$$

where α is the thermal diffusivity defined by $\alpha = \lambda / (\rho C_p)$.

The heat law allows to calculate some orders of magnitude. For example, we can determine the time τ that is necessary to reach the permanent regime in a ground where is buried a GHE. We assume for this calculation that the soil's temperature is constant *far* from the GHE (*i.e.* at a characteristic distance L from the GHE). The heat law can thus be rewritten:

$$\frac{\Delta T}{\tau} = \alpha \frac{\Delta T}{L^2} \quad (3)$$

and we deduce $\tau = L^2 / \alpha$.

For example, the heat exchange between a vertical GHE and the surrounding soil with $\alpha = 10^{-6} \text{ m}^2 \cdot \text{s}^{-1}$ reaches permanent regime at a distance of 5 m in 9 months and 19 days. After this time, the heat exchange is null and the system is inoperative. We see here the risk of using intensively such a heat exchanger: we must not pump heat continuously but intermittently. Inversely, the same type of calculation can determine the distance we must put between tubes when their operating duration is known. Finally, soil's thermal parameters have an effect on this calculation through the diffusivity α .

2. MODELING OF GROUND HEAT EXCHANGERS

To model GHE more precisely than with rough orders of magnitude, one must solve two distinct problems of heat transfer. Lamarche and Beauchamp (2007) summarized these problems as follows:

- (1) Heat transfer between the fluid in the tubes and the wall of the borehole. Due to the flow in the tubes, this transfer is partly convective. Most researchers solve this problem analytically making some approximations that we detail in subsection 2.1.1. Numerical approaches are used to deal with long-term evolution of the system (see section 2.2.1).
- (2) Heat transfer between the borehole and the soil by conduction. This problem needs a numerical resolution because the conduction is a transient phenomenon which takes place in a soil that is an heterogeneous and three-dimensional medium.

2.1 ANALYTICAL SOLUTIONS

On the basis of analytical solutions, we can understand the physics of heat transfers in GHE and it is possible to parameterize them. However, in order to get these solutions, we need to approximate the system and we cannot consider heterogeneous proprieties of the soil or complex dispositions of the tubes.

2.1.1 Temperature profile in undisturbed soil

Before we extract any heat, we must know the soil's temperature profile, as a function of depth and time. In order to determine this profile, we make the following assumptions:

H1: the surface temperature can be expressed as

$$T_S(z = 0, t) = T_{av} + \Delta T \cdot \cos[\omega(t - t_{min})] \quad (4)$$

where ω is the frequency of interest ($\omega = 2 \times 10^{-7} \text{ rad.s}^{-1}$ for a year and $\omega = 7.27 \times 10^{-5} \text{ rad.s}^{-1}$ for a day), T_{av} et ΔT are the average temperature and the amplitude of temperatures in a period $\tau = 2\pi/\omega$, and t_{min} is the date (in s) of the minimal temperature in the period,

- H2: the soil is homogeneous. In particular, it has a constant thermal diffusivity α_s (with depth, time and temperature),
- H3: there is no geothermal gradient in the ground (but only solar energy input),
- H4: there are no water flows, so that the heat exchanges are purely conductive. We can note that this is a very strong assumption. In real soils, water flows exist, vary depending on seasons and weather, induce convective heat exchanges and dramatically disturb the temperature profile we will calculate here.

To determine the temperature profile, we solve the heat equation (2). Kusuda and Archenbach (1965) were first to solve this equation in the soil. Many authors applied their work, especially in TRNSYS type 556 developed by Giardina (1995). The solution, drawn on figure ii can be written as follows:

$$T(z,t) = T_{av} + \Delta T \cdot e^{-z/\delta} \cdot \cos \left[\omega(t - t_{min}) - \frac{z}{\delta} \right] \quad (5)$$

This expression shows that the ground's thermal inertia induces both a phase delay and a damping of the temperature wave in depth. Both effects can be characterized by the penetration coefficient

$$\delta = \sqrt{\frac{2\alpha_s}{\omega}} \quad (\text{in m})$$

This penetration coefficient can be interpreted as the depth where the surface signal is damped by a 1/e factor. It determines the particular depth z_o where the temperature oscillation is in phase opposition with the surface temperature. Thus, in theory, horizontal tubes could extract heat stored in summer for use in winter if they are buried at a depth of $z_o = \pi \delta$.

Unfortunately, at this depth, the temperature damping is already $e^{-\pi} = 0.043$, which means a 95.7% loss of the signal intensity. Although extracting heat stored in the summer during winter seems attractive, it is not beneficial. Nevertheless, the damping is still an interesting phenomenon: the temperature is increasingly stable with growing depth. The expression of *undisturbed temperature* (5) is thus a first relation for dimensioning a GHE.

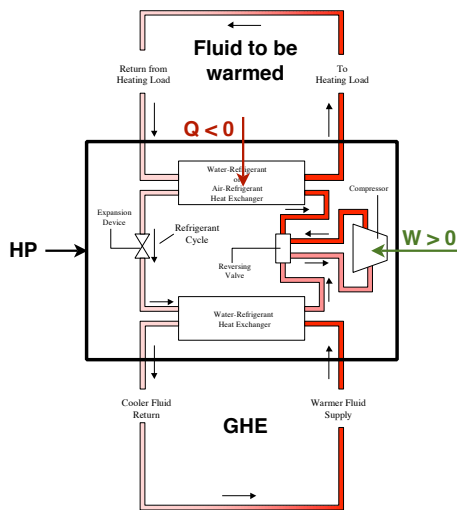

Figure i : Scheme of a HP coupled with a GHE. From Chiasson (1999).

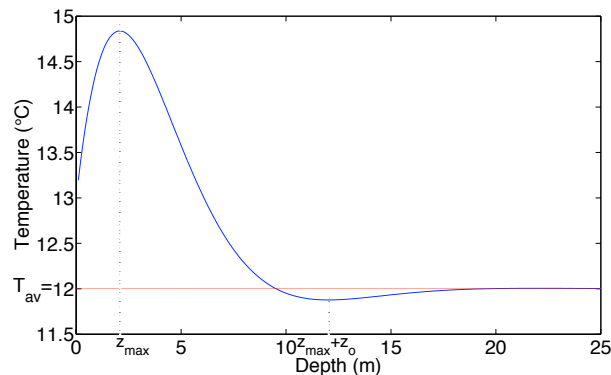

Figure ii : Temperature profile at March 21st in a homogeneous soil, with $\alpha = 10^{-6} \text{ m}^2 \cdot \text{s}^{-1}$, $T_{av} = 12^\circ \text{C}$, $\Delta T = 7.5^\circ \text{C}$ and $t_{min} = 0$ (i.e. 1st of January is the coldest day).

2.1.2 Modeling of the temperature at the tubes output

Subsection 1.1 demonstrated that greater the temperature T_{f_o} at the tubes output is, better is the COP of the heat pump. In his Ph.D. thesis, Hollmuller (2002) determines an analytical solution for the temperature at the x -coordinate in the tube:

$$T_f(x,t) = T_{f_i} + (T_{f_o} - T_{f_i}) \cdot \exp\left(-\frac{2\pi r_o}{C_{p_f} D_f} h x\right) \cdot \cos\left[\omega\left(t - \frac{x}{v_f}\right) - \frac{2\pi r_o}{C_{p_f} D_f} k x\right] \quad (6)$$

where h and k are functions of soil diffusive coefficients and of the convective coefficient h_f of the fluid.

It is important to notice in expression (6) that the convection of the fluid shifts the temperature phase between the fluid and the ground. Therefore, the lower the fluid velocity is, the greater is this phase difference. Consequently, this phenomenon could solve the problem whereby temperature phase shift through the earth induces a damping (subsection 2.1.1): reducing the fluid flow in the tubes also shifts the output temperature phase (this technique is called *low flow*).

Moreover, according to Hollmuller (2002), some values of h_f can privilege phase difference against damping. A phase delay almost without damping has even been experimentally brought out at small scale and over a time period of a day with a laminar fluid flow between two concrete plates. Unfortunately, this configuration cannot be applied to heat an entire building. Nevertheless, it could offer possibilities for horizontal GHE systems.

2.1.3 Models of temperature in the ground around the tubes

The Line-Source Theory (Hellström (1991)) proposes the following expression for the temperature in the soil around the borehole (located at the coordinate $r = 0$):

$$T(r,z,t) - T_{soil}(z,t) = \frac{q'}{4\pi\lambda_s} \int_{\frac{r^2}{4\alpha_s t}}^{+\infty} \frac{e^{-u}}{u} du \quad (7)$$

where T_{soil} is the *undisturbed temperature* given in subsection 2.1.1 and q' is the heat flow per length unit along the tube (W/m).

This model describes a global heat transfer along the entire tube that we consider to be a single section. In the earth, since the temperature difference between the soil and the fluid decreases along the tube (in the case of heat extraction), the heat flux is probably greater in the first sections of the tube than in the last ones. As a consequence, the heat flux which is calculated analytically with the LST often seems lower than this, which is numerically determined (see type 556, Giardina (1995)).

We can obtain the temperature profile in a ground where several boreholes are buried with the superposition principle of this type of solutions. However, we have to apply this superposition principle continuously *i.e.* at each time step of the calculation to attend the interference phenomena between each borehole. Thus, the modeling must be numerically processed.

2.2 NUMERICAL MODELING

2.2.1 Long-term interferences and thermal deviation in the soil

Lee and Lam (2008) used an implicit finite difference method to study the problem of thermal deviation in the soil that results from an *overpumping* of heat by several boreholes. To do this, the authors described the tubes with cylindrical slices. In each slice, they considered the mean temperatures T_f of the fluid and T_b of the borehole wall. They assumed that the heat transfer q between the fluid and the borehole obeys the law:

$$T_f - T_b = R_b q \quad (8)$$

where R_b is the thermal resistance of the entire GHE (tubes, fill material and wall of the borehole).

This approach draws an analogy between electric and thermal flux to describe the heat transfer, so that the resistance R_b is considered to be one of the principal parameters of a GHE system. Hellström

(1991) proposes an analytical expression for the resistance R_b as a function of geometrical and thermal characteristics of the tubes. Lee and Lam (2008) numerically get the temperature profile by superposing the solutions that they obtain for several boreholes. Their results suggest that a finite difference scheme is insufficient to estimate the performance of an entire field of boreholes. They conclude that we need to discretize simultaneously each borehole of the field to improve the accuracy of dynamical studies.

2.2.2 Numerical tools for integrating GHE into building simulation

In energy simulation of buildings most of the physical processes are modeled with a set of algebraic equations, mostly non-linear, differential and integral. Several tools exist which solve these equations with different methods. The dynamic simulation systems are the more precise because they solve equations iteratively over time with a given time-step. Such a well-known system is TRNSYS from University of Wisconsin¹ or Comfie/Pleiade3 from Ecole des Mines. For our simulations, we use the TRNSYS tool.

3. INFLUENCE OF THE SOIL’S THERMAL PARAMETERS

3.1 LITERATURE’S VALUES OF THERMAL PARAMETERS AND THEIR RELIABILITY

Some values of thermal conductivity λ , densities ρ and heat capacity C_p are given in books by Turcotte and Schubert (2001) and by Sleep and Fujita (1997), others are published on the Wikipedia website. We summarize them in the table i.

Table i : Values of thermal conductivity, heat capacity and diffusivity of some buildings, rocks and soils materials, dry or water-saturated (sat.).

Materials	λ (W.m ⁻¹ .K ⁻¹)	ρC_p (MJ.K ⁻¹ .m ⁻³)	α (.10 ⁻⁶ m ² .s ⁻¹)
Air	0.062	1.25×10^{-3}	50
Water	0.60	4.19	0.14
Concrete	0.92	2.11	0.44
Granite	2.2	2.13	1.03
Clay	0.2 (dry) to 1.6 (sat.)	0.3 (dry) to 3.2 (sat.)	0.50 (sat.) to 0.67 (dry)
Silt	0.2 (dry) to 2.5 (sat.)	0.60 (dry) to 2.4 (sat.)	0.33 (dry) to 1.0 (sat.)
Sand	0.3 (dry) to 3.2 (sat.)	1.0 (dry) to 2.4 (sat.)	0.30 (dry) to 1.3 (sat.)
Gravel	0.3 (dry) to 3.3 (sat.)	1.2 (dry) to 2.4 (sat.)	0.25 (dry) to 1.4 (sat.)

About the reported data, we can make some remarks:

- (1) According to these values, a diffusivity $\alpha = 10^{-6}$ m².s⁻¹, as we often find as default value in the simulations tools, would correspond to a granitic rock or to a soil composed by gravel, silt or water-saturated sand. But this value is not consistent with a dry soil or with clay.
- (2) Water increases the values of ρC_p and λ . The increase of ρC_p is due to the great heat storage capacity of water. The increase of λ whereas water is rather a better thermal insulator than the soil’s mineral components, may be due to thermal bridges that water build between the soil’s particles. At the contrary, in a dry soil, the interstices are filled with air, a very good insulator.

Thus, water is a very important component of soils whose content we must precisely know. Moreover, as moisture content varies seasonally and daily, we can imagine that water-dependent thermal parameters vary with time as well.

- (3) According to Fromentin et al. (1997), water has also a convective effect when in motion in soils. In a permeable layer, water can disperse the heat that is transferred from the tubes in the soil. On the one hand, this convective effect prevents a seasonal storage of heat in summer but on the other hand, it enables a quicker thermal reload in winter. The authors emphasized on the necessity to better understand heat transfers in porous media to model this effect. In this paper, we will neglect the convective phenomena, assuming that water does not move in soil.

¹TRNSYS homepage: <http://sel.me.wisc.edu/trnsys/index.html>

Some thermal properties of complex soils were given by Giardina (1995) and used in TRNSYS type 556. They are summarized in table ii.

Table ii : Complex soil's parameters from Giardina (1995).

Soil's type	Conductivity (W/m/K)	Diffusivity ($10^{-7}m^2/s$)	Density ($10^3kg/m^3$)	Specific heat ($10^2J/kg/K$)
Heavy saturated soil	2.43	9.03	3.20	8.38
Heavy damp soil	1.30	6.45	2.10	9.64
Heavy dry soil	0.87	5.16	2.00	8.38
Light damp soil	0.87	5.16	1.60	10.48
Light dry soil	0.35	2.80	1.44	8.38

Apart from the vague definition of the considered soils, without any information about composition, geologists would be astonished by the given densities: an *heavy saturated* soil is here as heavy as mantle rocks! Though, we saw in section 1.2 that soil's thermal parameters can largely impact calculations and dimensioning of the GHE. In the next section, we present TRNSYS simulation results to quantify the mistake due to erroneous thermal parameters values.

3.2 DIMENSIONING A GEOTHERMAL SYSTEM USING NUMERICAL SIMULATION EXPERIMENT

The previous remarks are supposed to have effects in dimensioning studies. In order to verify it, we simulate with the TRNSYS software the working of a commercialized product that contains:

- High-density polyethylene tubes, which must be horizontally buried.
- An hydraulic module with a 3-stages pump and input-output thermometers.
- An air/water heat exchanger.
- An 2-stages outdoor thermostat.
- Specific connections.

All components of the system already have fixed characteristics (thermal proprieties, pump flow, exchanger efficiency), so that the only parameters that are still to be determined is the length of the tubes and the soil's thermal parameters. As the constructor gives a value of around 1.2 m for the depth at which the tubes must be buried, we use this value to reduce the number of freedom degrees (although it may be varied to optimize the heat exchange).

Numerical simulation parameters are tested through the ground exchanger model implemented in TRNSYS type 556 in the climate of Saint Etienne, France, over a typical year. We tried to evaluate the maximum quantity of energy extractable for heating or cooling from the ground. This was done for several soil types corresponding to the parameters described in Table ii. Our results presented in Table iii show that in that range of usage, the main influent parameter is the soil's thermal conductivity while its density has a second role.

Thus, soil's parameters characterization and values choice for the numerical simulation is crucial. For instance, the water present in the soil will drastically change its conductivity and hence the thermal exchanges. One can note that the numerical tool's default values are somehow surprising. Indeed, while at low depth most soils are composed of sand and topsoil which correspond to Giardina's *light* soil, one can often found values corresponding to *heavy saturated* soils.

Figure iv shows the heat exchange as a function of the conductivity. For heat extraction, only low conductivity soils benefit from longer pipes. In the over hand, for cold extraction the pipe length is beneficial for all type of soils.

Figure iii obtained from simulations shows that for a given load to extract, soil's conductivity has significant influence on feasibility. Eventually, pipe length will allow for adjustment, especially with low conductivity. Thus the default values of the simulation tools can likely lead to system malfunction and mis-dimensioning for both heat and cold extraction.

For example, assuming that we want to extract 10^5 kJ/y from a *light dry* soil ($\lambda = 0.35$ W/m/K), figure iii shows that a calculation leads with a soil's conductivity $\lambda = 1.17$ W/m/K (so that $\alpha = 10^{-6}$

Table iii : Energy exchanged over a year, in typical Saint-Etienne climate external surface temperature, between the soil and an infinite load at 20°C.

	Heat (10 ⁸ J)	Cold (10 ⁸ J)	Heat (10 ⁸ J)	Cold (10 ⁸ J)	Heat (10 ⁸ J)	Cold (10 ⁸ J)
Pipe length	50 m		100 m		150 m	
Heavy saturated soil	0.80	-1.63	0.90	-2.08	0.90	-2.27
Heavy damp soil	0.78	-1.06	0.95	-1.57	0.97	-1.84
Heavy dry soil	0.79	-0.70	1.00	-1.15	1.07	-1.45
Light damp soil	0.80	-0.70	1.00	-1.15	1.08	-1.51
Light dry soil	0.96	-0.19	1.35	-0.38	1.69	-0.48

m².s⁻¹ as often assumed) will suggest a pipe’s length of 150 m (red dashed line). But in reality, 50 m would have been sufficient (red solid line): we could have made economies. Inversely, simulating the GHE with an over-estimated soil’s conductivity, we will not deduce enough length of pipe. Thus, the same heat exchange will induce a stronger temperature gradient, running the risk of a soil’s thermal impoverishment on the long view.

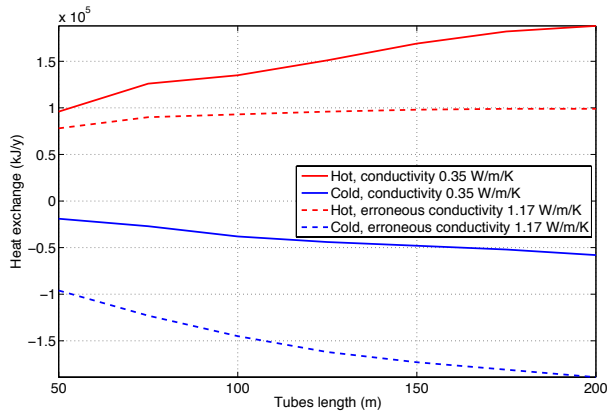

Figure iii : Influence of pipe length on the heat exchanges obtained from the TRNSYS GHE simulation component for extreme conductivities, namely light dry soil against literature’s default (erroneous) value.

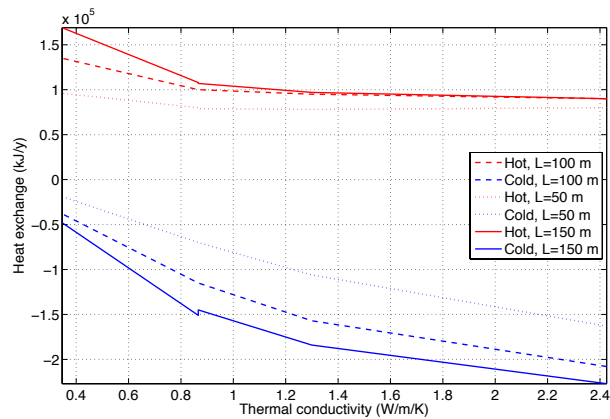

Figure iv : Influence of the soil’s conductivity values on the exchanger pipe length for maximum heat exchanges obtained from the TRNSYS GHE simulation component.

4. EXPERIMENTAL DETERMINATION OF THE SOIL’S THERMAL PROPERTIES

4.1 STATE AND OF THE ART AND ITS LIMITS

Most of studies on GHE modeling underline the importance of the soil’s thermal properties to design efficient systems (e.g. Hollmuller (2002), Chiasson (1999)). However, they rarely focus on this aspect. In the literature, there are few convenient methods to measure thermal parameters in soils at depth precisely. Usually, their values are estimated from a rough composition evaluation and tabulated values as in table i. Three principal elements affect these thermal properties:

- The composition of the soils and rocks in which the GHE are buried. As we saw in Table i, page 6, clay, silt, sand and granite have different thermal conductivities, densities and specific heats.
- The soil’s moisture content. With its large C_p , water has an effect on soil’s thermal diffusivity. Moreover, water can induce seasonal variations of soil’s properties.
- Groundwater flows, which improve the soil’s thermal reload through convective heat transfers.

Today, we use three major methods to estimate these parameters. First, Mogensen (1983) presents the *Temperature Response Test* (TRT). Recently, Mattsson et al. (2008) improved this method by reducing

the size of the required equipment. For the TRT, we build a GHE into which we inject a known heat power. We then measure the temperature at the tube's input and output to deduce the soil's diffusivity and the thermal resistance R_b of the borehole. With these parameters, we can calculate the heat transfer with the soil. With the output temperature, we can also calculate the COP of the heat pump. Although this method is efficient, it is obviously not convenient in the framework of a previous field study in order to determine the soil's properties for designing a GHE. Its application is only interesting to compare simulation results with field observations.

A third method is to measure thermal properties of small samples in a laboratory and establish tables of values for different types of soils. We deduce the value of the thermal conductivity of a certain soil according to those of its components. But this approach does not consider the variability of soils.

A third method concerns surface measurements. Bristow et al. (2001) give an example of a small probe which measures temperature, moisture content, electrical conductivity and thermal conductivity in the first ten centimeters of the ground. However, this kind of measurement is useful for agricultural studies but cannot access the soil at depth.

4.2 PERSPECTIVES WITH INDIRECT GEOPHYSICAL MEASUREMENTS

So far, thermal properties of soils seem difficult to measure, principally because of their dependence on composition and moisture content of the soils. As a consequence, Singh et al. (2001) propose to measure these properties indirectly. They use a relation between thermal resistivity and electrical resistivity, which is easy to measure. Indeed, the authors show experimentally that both of these resistivities (we note them R_E and R_T respectively) depend on moisture content S_r according to the following laws:

$$\log R_E = C_1 + C_2 \log S_r \quad \text{and} \quad \log R_T = C_3 + C_4 \log S_r \quad (9)$$

where C_1 , C_2 , C_3 and C_4 are constants which depend on the type of soil.

Bouchez et al. (2009) have verified these relations during an experimental lesson at ENS Lyon. Despite inherent experimental difficulties for measuring thermal conductivity, these relations seem us reliable and we can then deduce a relation between thermal and electrical resistivities:

$$\log \left(\frac{R_E}{R_E^o} \right) = \frac{C_2}{C_4} \log \left(\frac{R_T}{R_T^o} \right) \quad (10)$$

where, formally, $\log R_E^o = C_1$ and $\log R_T^o = C_3$.

In our study, equation (10) is under-determined: Measuring the electrical resistivity of a soil is not sufficient to infer its thermal resistivity. Even though we know the coefficients C_1 and C_4 from a measurement of electrical conductivity vs. water content, the R_T^o parameter is still unknown and only accessible through thermal measurements.

However, Singh et al. (2001) deduced from their observations a direct relation between R_E and R_T :

$$\log(R_E) = C_R \log(R_T) \quad (11)$$

where C_R only depend on the sand and gravel size fractions F of the soil: $C_R = 1.34 + 0.0085 \times F$.

Plotting the graph of $\log(R_T)$ vs. $\log(R_E)$ with consideration for the uncertainties due to the measurement, Bouchez et al. (2009) have some doubts about the reliability of such a linear regression. However, this kind of indirect measurement is promising to estimate the soil's thermal properties *in situ*. Assuming that for a given soil, thermal and electrical conductivities are both essentially governed by water content, we can apply the geophysical prospection methods developed in the field of hydrogeophysics (Rubin and Hubbard (2005) Robinson et al. (2008)) to profile, map or even monitor the electrical resistivity (or dielectric permittivity) at depth. Among these methods, we can cite:

- ground-penetrating radar (GPR, e.g. Huisman et al. (2003), Loeffler and Bano (2004)), which initially measured the dielectric permittivity. Present research tend to access to the electrical conductivity through *amplitude versus offset* approaches (Deeds and Bradford (2002)) or full-waveform inversion (Klotzsche et al. (2010)) but it requires significant calculation power.

- electrical resistivity tomography (ERT) which can provide hundred-meter-long electrical resistivity profiles, up to a few dozen meters deep (e.g. Rings et al. (2008), Koch et al. (2009), see figure v). ERT requires a specific multi-electrodes instrumentation but the software RES2DINV¹ enables to run the inversion on personal computers with an user-friendly interface.
- electromagnetic induction (EMI, e.g. Abdu et al. (2008)) which can quickly provide maps of *apparent* electrical conductivity, resultant value from the resistivities distribution at depth. Recently, Lavoué et al. (2010) improved the calibration of this method by coupling EMI values with ERT data. This advance open the possibility to get profiles of local values at depth with EMI as well.
- electric self-potential (SP) measurements which can be linked to groundwater flows through electrokinetic relations (e.g. Trique et al. (2002)).

Electrical conductivity and dielectric permittivity can then be converted into water content thanks to Archie's law (Archie (1942)) and Topp's equation (Topp et al. (1980)) respectively. However, these empirical laws are likely to depend on soil's characteristics and thus only provide a water content *scale* rather than reliable water content values. Nevertheless, it allows to have an overview of the spatial variations of electrical proprieties and water content and to plane time-monitoring to detect seasonal variations and groundwater circulation. In an ideal world, it could be applied to adapt the GHE dimensioning and its working along the year knowing the seasonal soil's characteristics.

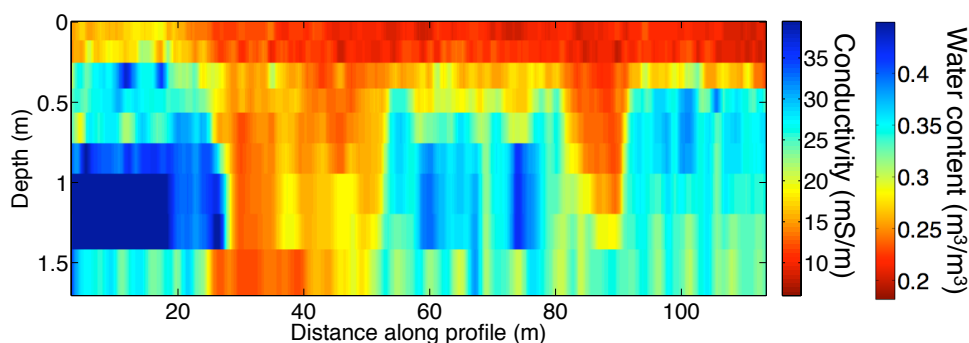

Figure v : ERT profile after Lavoué et al. (2010), converted into water content through a compact Archie's law ($\theta = 2.43\sigma^{0.48}$).

CONCLUSION AND PERSPECTIVES

We presented the modeling of GHE that has been made for many years and by many researchers, both with analytical and numerical methods. We then investigated a practical question which is rarely found in the literature: the influence of the soil's thermal parameters on GHE simulations. We used the TRNSYS software for the design of GHE test systems. Indeed, we showed that the required length of tubes depends *strongly* on the values of conductivity, and less on density and heat capacity of the soil.

As a consequence, an effort must be made in further research to improve *in situ* measurements of soil's thermal parameters in the framework of previous studies for dimensioning GCHP systems. To do so, we really believe in the possibilities that geophysical prospection offers with GPR, EMI or ERT methods. With these techniques, we can indeed have profiles of dielectric permittivity, electrical conductivity, and thus water content at depth. An interesting interpretation of these data would then be to convert them into thermal conductivity data. This interpretation would involve a relation between electrical resistivity, thermal resistivity and water content in the heterogeneous, porous, and multi-phasic media that are soils. We must still investigate this relation precisely to make it applicable.

¹<http://www.geoelectrical.com/index.php>

Acknowledgements

We want to thank Jean-Jacques Roux and Kim Eui-Jong from the INSA of Lyon for sharing their experience in dealing with TRNSYS and more generally in modeling GHE.

REFERENCES

- H. Abdu, D. A. Robinson, M. Seyfried, and S. B. Jones. Geophysical imaging of watershed subsurface patterns and prediction of soil texture and water holding capacity. *Water Resources Research*, 44,W00D18, doi:10.1029/2008WR007043, 2008.
- G. E. Archie. The electrical resistivity log as an aid in determining some reservoir characteristics. *Transactions of the American Intitute of Mining and Metallurgical Engineers*, 146:55–62, 1942.
- C. Bouchez, M. Chassande-Mottin, and F. Lavoué. Relation entre les résistivités électrique et thermique des sols. Technical report, ENS Lyon (*unpublished*), 2009.
- K. L. Bristow, G. J. Kluitenberg, C. J. Goding, and T. S. Fitzgerald. A small multi-needle probe for measuring soil thermal properties, water content and electrical conductivity. *Computers and electronics in agriculture*, 31: 265–280, 2001.
- A. D. Chiasson. Advances in modeling of ground-source heat pump system. Master’s thesis, University of Windsor, Ontario, Canada, 1999.
- J. Deeds and J. Bradford. Characterization of an aquitard and direct detection of Inapl at hill air force base using gpr avo and migration velocity analyses. Technical Report EMSP-70052, USDOE office of Environmental Management, 2002.
- A. Fromentin, D. Pahud, C. Jaquier, and M. Morath. Recommandations pour la réalisation d’installations avec pieux échangeurs. Technical Report 120.104, Office fédéral de l’énergie, 1997.
- J. J. Giardina. Evaluation of ground coupled heat pumps for the state of wisconsin. Mechanical engineering, University of Wisconsin-Madison, 1995.
- G. Hellström. *Ground Heat Storage Thermal Analysis of Duct Storage Systems. Part I. Theory*. PhD thesis, University of Lund, Sweden, Department of Mathematical Physics, 1991.
- P. Hollmuller. *Utilisation des échangeurs air/sol pour le chauffage et le rafraîchissement des bâtiments Mesures in situ, modélisation analytique, simulation numérique et analyse systémique*. PhD thesis, Université de Genève, Centre universitaire d’étude des problèmes de l’énergie, 2002.
- J. A. Huisman, S. S. Hubbard, J. D. Redman, and A. P. Annan. Measuring soil water content with ground penetrating radar: A review. *Vadose Zone Journal*, 2:476–491, 2003.
- A. Klotzsche, J. van der Kruk, G. A. Meles, J. A. Doetsch, H. Maurer, and N. Linde. Full-waveform inversion of cross-hole ground-penetrating radar data to characterize a gravel aquifer close to the thur river, switzerland. *Near Surface Geophysics*, 8, 2010.
- K. Koch, J. Wenninger, S. Uhlenbrook, and M. Bonell. Joint interpretation of hydrological and geophysical data: Electrical resistivity tomography results from a process hydrological research site in the black forest mountains, germany. *Hydrological Processes*, 23:1501–1513, 2009.
- T. Kusuda and P. R. Archenbach. Earth temperature and thermal diffusivity at selected stations in the united states. *ASHRAE Transactions*, 71(Part 1), 1965.
- L. Lamarche and B. Beauchamp. A new contribution to the finite-line model for geothermal boreholes. *Energy and Buildings*, 39:188–198, 2007.
- F. Lavoué, J. van der Kruk, J. Rings, F. André, D. Moghadas, J. A. Huisman, S. Lambot, L. Weihermüller, J. vanderBorgh, and H. Vereecken. Electromagnetic induction calibration using apparent electrical conductivity modelling based on electrical resistivity tomography. *Near Surface Geophysics*, 8:553–561, 2010.
- C.K. Lee and H.N. Lam. Computer simulation of borehole ground heat exchangers for geothermal heat pump systems. *Renewable Energy*, 33:1286–1296, 2008.
- O. Loeffler and M. Bano. Ground penetrating radar measurements in a controlled vadose zone: Influence of the water content. *Vadose Zone Journal*, 3(4):1082–1092, 2004. doi: 10.2113/3.4.1082.
- J. Lund, B. Sanner, L. Rybach, R. Curtis, and G. Hellström. Geothermal (ground-source) heat pumps, a world overview. *Renewable Energy*, 2003.
- N. Mattsson, G. Steinmann, and L. Laloui. Advanced compact device for the in situ determination of geothermal characteristics of soils. *Energy and Buildings*, 40:1344–1352, 2008.
- P. Mogensen. Fluid to duct wall heat transfer in duct system heat storages. In *Proceedings of the international conference on subsurface heat storage in theory and practice*, pages 652–7, Stockholm, Sweden, 1983.
- J. Rings, A. Scheuermann, K. Pekro, and C. Hauck. Soil water content monitoring on a dike model using electrical resistivity tomography. *Near Surface Geophysics*, pages 123–132, 2008.
- D. A. Robinson, A. Binley, N. Crook, F. D. Day-Lewis, T. P. A. Ferré, V. J. S. Grauch, R. Knight, M. Knoll, V. Lakshmi, R. Miller, J. Nyquist, L. Pellerin, K. Singha, and L. Slater. Advancing process-based watershed hydrological research using near-surface geophysics: a vision for, and review of, electrical and magnetic geophysical methods. *Hydrological Processes*, 22:3604–3635, 2008.

- Yoram Rubin and Susan S. Hubbard, editors. *Hydrogeophysics*. Springer, 2005.
- D. N. Singh, S. J. Kuriyan, and K. C. Manthena. A generalised relationship between soil electrical and thermal resistivities. *Experimental Thermal and Fluid Science*, 25:175–181, 2001.
- N. H. Sleep and K. Fujita. *Principles of Geophysics*, pages 134–203. Blackwell Science, 1997.
- G. C. Topp, J. L. Davis, and A. P. Annan. Electromagnetic determination of soil water content: measurements in coaxial transmission lines. *Water Resources Research*, 16(3):574–582, 1980.
- M. Trique, F. Perrier, T. Froidefond, and J.-P. Avouac. Fluid flow near reservoir lakes inferred from the spatial and temporal analysis of the electric potential. *Journal of Geophysical Research*, 107(B10):2239, doi:10.1029/2001JB000482, 2002.
- D. L. Turcotte and G. Schubert. *GEODYNAMICS Application of continuum physics to geological problems*, pages 134–197. John Wiley and Sons, 2001.
- Wikipedia. Liste des conductivités thermiques.
http://fr.wikipedia.org/wiki/Liste_des_conductivit%C3%A9s_thermiques.