



HAL
open science

Computing the average path length and a label-based routing in a small-world graph

Philippe Giabbanelli, Dorian Mazauric, Stéphane Pérennes

► **To cite this version:**

Philippe Giabbanelli, Dorian Mazauric, Stéphane Pérennes. Computing the average path length and a label-based routing in a small-world graph. 12èmes Rencontres Francophones sur les Aspects Algorithmiques de Télécommunications (AlgoTel), 2010, Belle Dune, France. pp.TBA. inria-00472215

HAL Id: inria-00472215

<https://inria.hal.science/inria-00472215>

Submitted on 10 Apr 2010

HAL is a multi-disciplinary open access archive for the deposit and dissemination of scientific research documents, whether they are published or not. The documents may come from teaching and research institutions in France or abroad, or from public or private research centers.

L'archive ouverte pluridisciplinaire **HAL**, est destinée au dépôt et à la diffusion de documents scientifiques de niveau recherche, publiés ou non, émanant des établissements d'enseignement et de recherche français ou étrangers, des laboratoires publics ou privés.

Computing the average path length and a label-based routing in a small-world graph[†]

Philippe J. Giabbanelli, Dorian Mazauric, and Stéphane Pérennes

Mascotte, INRIA, I3S(CNRS,UNS), Sophia Antipolis, France

Nous étudions deux caractéristiques d'un graphe petit monde proposé par Zhang *et al.* pour modéliser des graphes de terrain. Notre étude s'appuie sur la structure récursive du graphe. D'une part, nous l'utilisons pour concevoir un schéma d'étiquetage afin d'obtenir un routage implicite (*i.e.* basé sur les étiquettes des sommets). D'autre part, prouver la distance moyenne dans ce graphe était délicat, ainsi Zhang *et al.* ont choisis d'étudier le diamètre : la structure récursive nous permet d'établir la preuve de la distance moyenne, et ainsi de caractériser que le graphe est petit-monde et non ultra petit-monde comme cela restait possible. Notre preuve est d'un intérêt tout particulier pour être adaptée à d'autres graphes construits sur des structures récursives similaires.

Keywords: Recursive graph, Labeling scheme, Decentralized routing

1 Introduction

Numerous networks such as social networks were shown to share properties, including a power-law degree distribution, which is known as the *scale-free* property. It was shown that when an individual joins a population by befriending the most social individuals, then the scale-free property naturally emerges. Furthermore, if one friend introduces the newcomer to one of his friends, then the *small-world* property is also obtained [3] : the average distance between individuals is small, and there is a high clustering coefficient (*i.e.*, likelihood that if a is friend with b and b is friend with c then a is also friend with c). In Section 2, we recall the definition from [6] of a model based on these principles, and we propose a labelling scheme. We use the labels to enumerate all edges of the model and, in Section 3, to design a decentralized routing algorithm. To show that their model was small-world, the authors of [6] chose to study the diameter rather than the average path length. In Section 4, we provide an analytical expression of the average path length, using the recursive structure of the graph. Our expression proves that the graph is precisely small-world (*i.e.* its average path length grows logarithmically in the network's size), since alternatives include ultra-small. Analytical expressions for the average path length have shown to be of particular interest [4], thus a promising future work consists of adapting our proof to other recursive graphs such as [5].

2 Definition and labelling

The undirected graph defined by Zhang, Rong and Guo [6] relies on an iterative process. We denote by ZRG_0 the empty graph, ZRG_1 is the first step corresponding to a cycle of three nodes, and " ZRG_t is obtained by ZRG_{t-1} by adding for each edge created at step $t-1$ a new node and attaching it to both end nodes of the edge" [6]. For example, Figure 1(a) represents ZRG_4 . The design of a labelling scheme that allows decentralized routing was investigated for a similar undirected graph M_t [2]. The model starts with M_0 being the empty graph, and M_1 being a pair of nodes s_0, s_1 connected by an *active* edge. At time $t = 2$, two nodes a and b are added as a path s_0, a, b, s_1 ; the edge $\{s_0, s_1\}$ that was previously active becomes inactive, while the edges $\{s_0, a\}$ and $\{b, s_1\}$ become active. Thus, this model consists of adding a path for each active edge and making the two end edges of the new paths active. Formally, at time t , a path u, i, j, v is created for all active edges $\{u, v\}$. Then, $\{u, v\}$ becomes inactive while $\{u, i\}$ and $\{j, v\}$ are active. The

[†]Research support by région PACA, ANR AGAPE, and ANR DIMAGREEN.

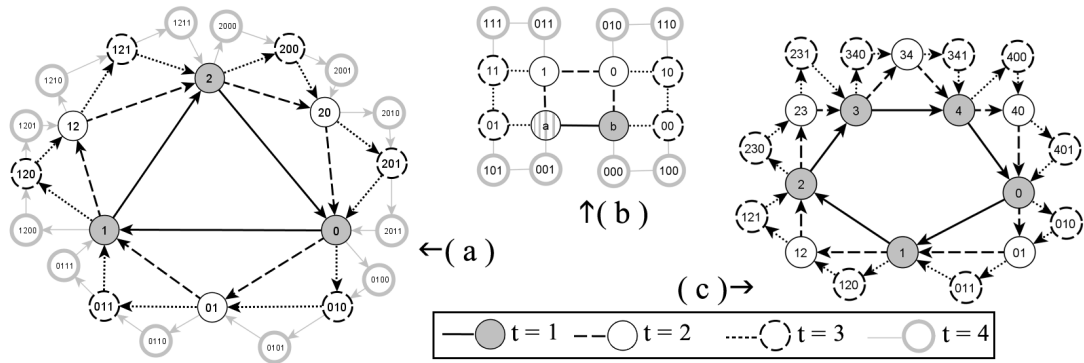

FIGURE 1: Labels for ZRG_4 (a), M_4 (b), and a variant of ZRG_3 (c) starting with a cycle of length 5. The legend shows the step at which nodes and edges were created, and the hatched node a in M_4 is a special case created at $t = 0$.*

result for M_4 is illustrated in Figure 1(b). Both ZRG_t and M_t are defined by a recursive addition of patterns, but they exhibit very different properties. Firstly, the clustering coefficient of M_t is 0, whereas the value is asymptotically 0.69 for ZRG_t which is deemed high. Indeed, the clustering coefficient relies solely on triangles (*i.e.*, cycles of length 3) and M_t is triangle-free. Secondly, the labelling scheme of M_t cannot be used for ZRG_t . In M_t , for a given edge with two end nodes labelled $L(u)$ and $L(v)$, the two nodes created at time $t + 1$ are labelled $0L(u)$ and $1L(u)$ respectively. By adding *one* node instead of two, labels are no longer unique : if $L(u) = 0$ and $L(v) = 1$ at time $t - 1$ then we add a node labelled 00 connecting them at time t , and at time $t + 1$ we will add a node between 0 and 00 which will also be labelled 00 .

Our labelling scheme for ZRG_t works as follows. At time $t = 1$, we label the vertices in the initial cycle 0 , 1 and 2 , and we define an orientation* of the graph $0 \rightarrow 1 \rightarrow 2$. At time $t = 2$, the edge from u to v is labelled $L(u)L(v)$. At time t , for a given node u created at time $t - 1$ with label $L(u)$, we label by $0L(u)$ the node created for the incoming edge and $1L(u)$ the node created for the outgoing edge. The result is illustrated in Figure 1(a). Similarly to the proof in [2], Theorem 1 establishes that this scheme guarantees distinct labels. Overall, a node added at time t is labelled by the word x_1, \dots, x_t where $x_i \in \{0, 1\}$, $i = 1..t$. This scheme can be trivially extended to the case in which ZRG_1 is defined as a cycle of size q , as shown in Figure 1(c) for $q = 5$. Furthermore this extension also has high clustering coefficient since adding triangles matters more than the initial cycle, and q allows graphs $ZRG_{t,q}$ with customized number of nodes $q2^{t-1}$ instead of $3 \cdot 2^{t-1}$.

Theorem 1. Each node of ZRG_t has a unique label.

Proof. At $t = 1$, all nodes have distinct labels 0 , 1 and 2 , and at $t = 2$ they have distinct labels 01 , 12 and 20 . By induction on t , we assume that this is true at time $t - 1$. For each node u of $t - 1$, the added nodes are labelled $0L(u)$ and $1L(u)$, which are distinct labels. Since all labels in $t - 1$ are distinct, this holds for t . \square

We observe that the node u labelled 0 is connected to all nodes whose labels start with 01 and is followed only by 0 s. Indeed, at time $t = 1$, we create a node labelled 01 for the outgoing edge of 0 . At time $t = 2$, the outgoing edge from u is the incoming edge of 01 thus the new node is labelled 011 , and this follows by induction. Using the same reasoning, Table 1 lists all possible edges of the graph. The table uses the following short notation : $\underline{0}$ and $\underline{1}$ denote a (possibly empty) sequence of 0 s and 1 s respectively, and $|X|$ denotes the number of symbols in a label X .

3 Decentralized routing

Lets consider that we want to find the shortest path from a node u to a node v . First, we present a few cases to illustrate the main principles of our routing algorithm. **(a)** If $L(u) = Xy$ and $L(v) = X\bar{y}$, with y a single letter, then we say that u and v are cousins. Informally, they have been created at the same step for the incoming and outgoing edges of the node labelled X . Thus, the shortest path consists of going to X and then

*. The graph ZRG_t is undirected, and the orientation is defined only for the labelling and the proof of the average distance.

Label of u	Label of v
0, 1, 2	0, 1, 2
xy	x, y
0	01 $\underline{0}$, 20 $\underline{1}$
1	12 $\underline{0}$, 01 $\underline{1}$
2	20 $\underline{0}$, 12 $\underline{1}$
$X, X > 1$	$X1\underline{0}, X0\underline{1}$

TABLE 1
Edges of ZRG_t

Algorithm 1 $Move(u, v)$

- 1: IF $u = v$, stop.
 - 2: IF u is neighbor of v , $Move(u, u)$
 - 3: IF $L(u) = xy$ and $L(v) = z$, $Move(L(y), v)$
 - 4: IF $L(u) = Xy$ and $L(v) = X\bar{y}$, $Move(L(X), L(X))$
 - 5: $Move(oldAncestor(u), oldAncestor(v))$
-

directly to the target. Note that cousins do not exist in the graph M_t : a node chooses between sending the message to its ‘brother’ or its parent, and always chooses the latter unless the target is the former. **(b)** If the nodes are not cousins, then we move simultaneously from u and v to their oldest ancestors, which defined as the node with the shortest label and is obtained via $oldAncestor(u)$. We check if the nodes on which we moved are cousins, in which case we apply case (a), or we keep on moving until we reach either a node of ZRG_0 or a node of ZRG_1 . **(c)** If both u and v belong to nodes of ZRG_1 , then they are direct neighbors and we stop. If both belong to nodes of ZRG_2 , then they move to the node having as label their common letter. For example, if $L(u) = 12$ and $L(v) = 01$ then they move on 1. Otherwise, w.l.o.g. we consider that u is on a node of ZRG_2 and v is on a node of ZRG_1 . The node u has a label xy and we move to y , which is guaranteed to be a neighbor of v . The process is given by Algorithm 1 in which $L(X)$ refers to the node with label X .

4 Average path length

The average path length of a connected graph G is defined by $\ell(G) = \frac{\sum_{u \in V(G)} \sum_{v \in V(G)} d(u, v)}{|V(G)| \cdot (|V(G)| - 1)}$, where $d(u, v)$ is the length of a shortest path between u and v . To compute $\ell(ZRG_t)$, we define an auxiliary function $g(t)$ that denotes the number of nodes *added* at step $t \geq 1$.

Lemma 1. $g(t) = \frac{3}{4} \cdot 2^t, t \geq 2$, and $g(1) = 3$

Proof. We prove by induction that $g(t) = 2g(t-1), t \geq 2$, and the recurrence is straightforwardly solved into $g(t) = \frac{3}{4} \cdot 2^t$. We observe that $g(1) = g(2) = 3$ and $g(3) = 6$. We assume that $g(t) = 2g(t-1)$ holds up to t . By construction of ZRG_{t+1} , one node at time $t+1$ is added for all edges created at time t , and there are $2g(t)$ such edges since two were created for each of the $g(t)$ nodes. \square

Theorem 2. $\ell(ZRG_t) = \frac{-2^{t-1} + 2^t t + 1}{3 \cdot 2^{t-1} - 1}$

Proof. For the sake of clarity, let $\ell(ZRG_t) = f(t) / (|V(ZRG_t)| \cdot (|V(ZRG_t)| - 1))$. First, we prove that $f(t+1) = 4f(t) + 3g(t+1)^2 - g(t+1) - g(t+1)h(t+1), t \geq 2$, where $g(t)$ is the number of nodes added at time $t \geq 2$ and $h(t) = \frac{2^t}{8} + 1$ is a correcting factor that will be explained in the proof. Let $V(ZRG_t) = \{v_1, \dots, v_m\}$ denote the nodes in ZRG_t , and let $A_{t+1} = \{a_1, \dots, a_m\}$ denote the nodes added to $V(ZRG_t)$ at time $t+1$. We associate each new node a_i to the node v_i accessed by the outgoing edge $(a_i, v_i) \in E(ZRG_{t+1})$. Our proof is in three steps: (a) we approximate the shortest path distance between nodes of A_{t+1} and nodes of $V(ZRG_t)$, (b) we approximate the shortest path distance between nodes of A_{t+1} , and (c) we correct the approximations by introducing a correcting factor.

(a) Lets consider that we virtually ‘collapse’ each a_i with its associated v_i : all routings involving an a_i are assumed to go through its v_i and the edge (a_i, v_i) is free. Instead of having one path for each pair (v_i, v_j) , we now have four paths between the pairs (v_i, v_j) , (v_i, a_j) , (a_i, v_j) and (a_i, a_j) . Thus, $f(t+1) \approx 4f(t)$. We now have to consider the edge connecting each a_i to its associated v_i . There are $g(t+1)$ nodes in A_{t+1} and also $g(t+1)$ nodes in $V(G_t)$ (see Lemma 1): since all of the formers need to send a message to all of the latters, and the other way around, the extra factor is $2g(t+1)^2$. Thus, $f(t+1) \approx 4f(t) + 2g(t+1)^2$.

(b) Each of the new nodes in A_{t+1} wants to reach all nodes in A_{t+1} but itself. Thus, a new node reaches $g(t+1) - 1$ new nodes, hence $g(t+1)(g(t+1) - 1)$ for all nodes. By combining with (a), we have $f(t+1) \approx 4f(t) + 3g(t+1)^2 - g(t+1)$.

(c) The approximations considered so far that the a new node a_i was always routing through its associated node v_i . However, some routes are shorter through the alternative neighbor v_{i-1} rather than through v_i (see Figure 2(a)). There are on average $h(t)/2$ corrections for outgoing routes and as many for incoming routes. For the sake of clarity, the following argument only discusses outgoing requests from a_i but, *due*

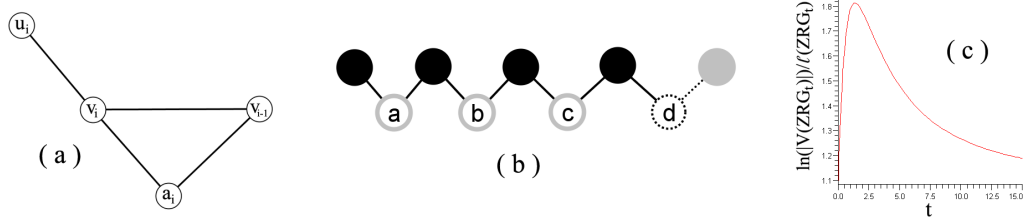

FIGURE 2: A new vertex a_i and its associated node v_i (a). The paths from v_i to $h(t)$ targets are shorter by going through v_{i-1} rather than u_i , thus when a_i wants to send a message to these $h(t)$, it does so through v_{i-1} . Going from an a_i to the $h(t)$ black nodes is more efficient through the alternative neighbor v_{i-1} of a_i than through v_i (b), thus it is also more efficient to go to the $h(t) - 1$ new nodes a, b and c ; d can be accessed by the gray node which is routed through the associated neighbor v_i of a_i . The average distance in ZRG_t is close to the logarithm of the graph's size (c).

to symmetry of requests, we use the notation $h(t)$ for the average number of requests from an a_i that are best routed through the alternative neighbor rather than the associated one. Thus, we want to prove that $f(t+1)$ must be corrected by a factor $g(t+1)h(t+1)$ where $h(t+1) = 2h(t-1)$, $t \geq 3$, $h(3) = 3$. We assume that we need to correct $g(t)h(t)$ nodes at time t and we prove it by induction. First, we have $f(3) = 4f(2) + 3g(3)^2 - g(3) - g(3)h(3) = 4.42 + 3.6^2 - 6 - 6.3 = 252$, which is verified. At time $t+1$, we consider a node a_i added at time $t+1$. By induction, its associated vertex v_i was already routing messages toward $h(t)$ targets on average through v_{i-1} rather than its associated u_i . Thus, a_i will also use v_{i-1} to route through the same $h(t)$ targets. Since these targets were created at time t , they also have new nodes and a_i will use v_{i-1} to route to $h(t) - 1$ of these new nodes; the last one is not included since one of its endpoints was routed through the associated node (Figure 2(b)). By summing, we obtain that a_i uses v_j to route toward $2h(t) - 1$ nodes. By considering all nodes a_i added at time $t+1$ we have to correct $g(t+1)(2h(t) - 1)$ routes.

We proved that $f(t+1) = 4f(t) + 3g(t+1)^2 - g(t+1) - g(t+1)h(t+1)$, $t \geq 2$, $g(t) = \frac{3}{4}2^t$, and $h(t) = \frac{2^t}{8} + 1$. By algebraic simplification, we have $f(t) = -3.2^{2t-2} + \frac{3}{2}t4^t + 3.2^{t-1}$. To obtain the average path length, we divide by $|V(ZRG_t)| \cdot (|V(ZRG_t)| - 1)$. Since $|V(ZRG_t)| = 3.2^{t-1}$ [6], we simplify $\frac{f(t)}{(3.2^{t-1}) \cdot (3.2^{t-1} - 1)}$ and we obtain the result of the theorem. \square

The average distance ℓ in a graph with N nodes is said to be *small* when ℓ is proportional to $\ln(N)$ and *ultrasmall* when ℓ is proportional to $\ln(\ln(N))$ [1]. We observe that $\lim_{t \rightarrow \infty} \frac{\ln(|V(ZRG_t)|)}{\ell(ZRG_t)} = \frac{3 \cdot \ln(2)}{2} \approx 1.03$ whereas $\lim_{t \rightarrow \infty} \frac{\ln(\ln(|V(ZRG_t)|))}{\ell(ZRG_t)} \approx 0$. Thus, the average size is almost exactly $\ln(|V(G)|)$ for large t . This is deemed small, and can be expected since the graph is biconnected outerplanar and the weak dual of such a graph is a tree. Since the size of the graph is exponential in t , it is important that the graphs obtained for small values of t have a similar ratio, which is confirmed by the behaviour illustrated in Figure 2(c).

The proof of Theorem 2 could be adapted to extensions of ZRG_t such as [5] in which a node is created with probability p . An approximation and an upper bound were given for the average path length, thus it would be of particular interest to extend our method to this probabilistic case.

Références

- [1] R. Cohen and S. Havlin. Scale-free networks are ultrasmall. *Physical Review Letters*, 90, 2003.
- [2] F. Comellas and A. Miralles. Vertex labeling and routing in self-similar outerplanar unclustered graphs modeling complex networks. *Journal of Physics A : Mathematical and Theoretical*, 42, 2009.
- [3] J. Davidsen, H. Ebel, and S. Bornholdt. Emergence of a small world from local interactions : Modeling acquaintance networks. *Physical Review Letters*, 88(12), 2002.
- [4] Z. Zhang, L. Chen, S. Zhou, L. Fang, J. Guan, and T. Zou. Analytical solution of average path length for apollonian networks. *Physical Review E*, 77, 2008.
- [5] Z. Zhang, L. Rong, and F. Comellas. Evolving small-world networks with geographical attachment preference. *Journal of Physics A : Mathematical and General*, 39 :3253–3261, 2006.
- [6] Z. Zhang, L. Rong, and C. Guo. A deterministic small-world network created by edge iterations. *Physica A : Statistical Mechanics and its Applications*, 363(2) :567–572, 2006.