



HAL
open science

QoS-aware Routing for Real-Time and Multimedia Applications in Mobile Ad Hoc Networks

David Espes, Zoubir Mammeri

► **To cite this version:**

David Espes, Zoubir Mammeri. QoS-aware Routing for Real-Time and Multimedia Applications in Mobile Ad Hoc Networks. 17th International Conference on Real-Time and Network Systems, Oct 2009, Paris, France. pp.67-74. inria-00441968

HAL Id: inria-00441968

<https://inria.hal.science/inria-00441968>

Submitted on 17 Dec 2009

HAL is a multi-disciplinary open access archive for the deposit and dissemination of scientific research documents, whether they are published or not. The documents may come from teaching and research institutions in France or abroad, or from public or private research centers.

L'archive ouverte pluridisciplinaire **HAL**, est destinée au dépôt et à la diffusion de documents scientifiques de niveau recherche, publiés ou non, émanant des établissements d'enseignement et de recherche français ou étrangers, des laboratoires publics ou privés.

QoS-aware Routing for Real-Time and Multimedia Applications in Mobile Ad Hoc Networks

David Espes, Zoubir Mammeri
IRIT – Paul Sabatier University
Toulouse, France
espes@irit.fr, mammeri@irit.fr

Abstract

With the increasing development of real-time and multimedia applications, there is a need to provide bandwidth and delay guarantees. Most of QoS ad hoc network routing protocols select path guaranteeing delay and/or bandwidth. However, they don't consider throughput optimization, which results in a low number of admitted real-time and multimedia flows. In this paper, we propose a cross-layer TDMA-based routing protocol to meet delay and bandwidth requirements while optimizing network throughput. Since in TDMA-based ad hoc networks, slot reservation impacts two-hops neighbors, our routing protocol selects paths with the lowest number of neighbors. To show the effectiveness of our protocol, we present simulations using NS-2.

1. Introduction

With the continuously growing wireless technologies, mobile Ad hoc networks (MANETs) have emerged as a popular area of research. Recent growing interest in using MANETs to support real-time and multimedia applications led to the need to consider QoS support. One of the key issues to provide QoS guarantees in MANETs is routing.

Most routing protocols for MANETs, such as AODV [1], OLSR [2], DSR [3], are designed without explicitly considering QoS of the routes (also called paths) they select. Hop number is the most common criterion adopted by such routing protocols. It is becoming increasingly clear that such routing protocols are inadequate for real-time and multimedia applications, such as installation/environment monitoring and video conferencing, which often require QoS guarantees. QoS routing must find a path -from source to destination- which meets QoS requirements. In conventional wired networks, QoS

support is easier to provide than in wireless networks. Moreover, the unpredictable and potentially rapid changes in routes and bandwidth availability are some significant challenges which need to be addressed before QoS techniques can be deployed in MANETs.

In spite of these difficulties, some QoS routing protocols in MANETs have been proposed, such as QoS-AODV [4], ODQOS [5], ADQR [6], QuART [7], MSMR [8], QoS-ASR [9], TDR [10], TBP [11], QRMP [12], QuaSAR [13], AQOR [14] and LAOR [15]. These protocols provide reactive routing, where control (i.e. routing) packets are only transmitted when important events occur such as route creation or route breakage. Almost all these protocols use slot reservation techniques during the creation route phase. None optimize the network bandwidth. They consider bandwidth constraints (eg. ADQR and ODQOS), delay constraints (eg. MSMR and LAOR) or both (eg. QoS-AODV), but don't meet these constraints while optimizing the network throughput.

We propose a reactive routing protocol, which provides bandwidth and delay constraints. The basic idea of our protocol to optimize network throughput is to minimize the number of neighbors associated with paths. Selecting paths with a low number of flows on neighboring nodes results in fewer collisions thus in more available slots to be used by nodes to establish real-time connections.

The rest of the paper is organized as follows. Section 2 is an overview of related work. Section 3 analyzes how time slots allocated to a flow may impact network throughput. Section 4 presents our routing protocol. Section 5 presents simulation results. Finally, we conclude the paper in section 6.

2. Related work

Providing QoS guarantees in MANETs is a challenge. Indeed node movement (i.e. network topology changes), low bandwidth, interferences and

collisions, make it very difficult to meet QoS constraints imposed by real-time and multimedia applications.

For collision avoidance, QoS routing protocols may use MAC protocols with no contention such as TDMA or CDMA-over-TDMA. In TDMA-based MANETs [16], nodes use their reserved slots to transmit data without collisions. Using contention-free MAC protocols, QoS routing protocols may easily provide some QoS guarantees in terms of bandwidth, delay, and jitter.

Other routing protocols may provide QoS guarantees even over contention MAC protocols. However, they only provide soft QoS guarantees. Consequently, observed QoS metrics (eg. delay or bandwidth) may exceed those bounds required by real-time and multimedia applications.

The following is a brief introduction to the most known and innovative routing protocols which provide bandwidth and/or delay guarantees. QoS-AODV [4], QoS-ASR [9], TDR [10], and AQOR [14] are reactive routing protocols, which provide bandwidth and delay guarantees

QoS-AODV forwards route search request only if the path meets bandwidth constraint and has a delay lower than the one of already received requests (if any). This protocol setups slot allocation when the source receives the route acknowledgement.

ODQOS [5] is a TDMA-based reactive routing protocol. It selects path to the destination with the minimum delay (or hops if the delay is the same for all paths). During the route search phase, all nodes, which receive a route request, reserve appropriate free slots. During the route acknowledgement phase, nodes that aren't on the selected path release reserved slots.

ADQR [6] is a multiple disjoint path reactive routing protocol. During route search phase, when a node receives a request, it forwards it only if the route is disjoint with previously received requests and the bandwidth requirements are met. Periodically, nodes transmit Hello packets. Neighbors determine signal strength and stability of the sender node. Source node selects the path with the highest stability. Resource reservation is done once the source node has selected the path.

QuART [7] is a reactive routing protocol, which selects routes with available bandwidth higher than required bandwidth. To correctly estimate the available bandwidth, route selection takes into account the potential interferences. Periodically, nodes send packets with their available bandwidth. When nodes receive these packets, they determine, according to the

signal strength, if the sender is in the interference area or in the transmission area.

TBP [11] is another reactive routing protocol. It uses tickets to find route with QoS. Two types of tickets are used: yellow and green. A yellow ticket indicates a preference for paths with shorter delay. A green ticket indicates preference for lower-cost paths. Three levels of path redundancy are provided in TBP.

To determine eligible path, QoS-ASR protocol [9] uses a weight function taking into account seven metrics. During route search phase, nodes broadcast route request only if the sub-path meets the delay and bandwidth requirements and the path weight is less than a threshold.

With TDR protocol [10], each node sends periodically packets with its location and its mobility information. This protocol provides two methods to reroute packets when a breakage in the route is imminent. Nodes detect imminent breakage situations according to the signal strength of periodic packets.

AQOR [14] is IEEE 802.11 MAC based. Periodically, each node transmits Hello packets to inform its neighborhood about its available bandwidth. When a node receives a route request packet, it forwards the packet if it has sufficient available bandwidth.

None of the previous protocols optimize the network throughput. That is why, we propose a routing protocol to reduce time slot wasting due to the selection of paths including many neighbors.

3. Slot allocation impacts

In order to allocate the medium without collisions in the TDMA environment, the medium access time is divided into superframes. Each superframe is divided into control and data time slots. Each node is assigned a control time slot it uses to transmit its control information. The rest of the superframe is used for data transfer. Nodes must compete to reserve time slots.

A time slot s is considered free and may be allocated to send data from a node x to a node y if the following conditions hold [17]:

- 1) Slot s is not scheduled for receiving or transmitting in both nodes.
- 2) Slot s is not scheduled for receiving in any node z which is a 1-hop neighbor of node x .
- 3) Slot s is not scheduled for sending in any node z which is a 1-hop neighbor of node y .

When time slots are allocated on a link (x, y) , 1-hop neighbours cannot use them, otherwise interferences may occur. Allocated time slots on a link impact nodes

of this link but also their neighbours. The higher the neighbour number is, the more important the impact of slot allocation is. "Time slot allocation impact" means how allocation of some time slots to support a flow f may prevent nodes to send or receive data packets other than flow f packets. Decreasing the number of free slots results in a decrease of either the bandwidth assigned to nodes or the number of admitted flows.

Slot allocation impacts two subsets of nodes: nodes forwarding the data packet of the new flow (i.e. nodes forming the new path) and their neighbour nodes. When slots are allocated on a link $\langle x, y \rangle$:

- the previous hop of x doesn't receive data in these slots and the next hop of y can't send data in these slots to avoid interferences,
- all nodes in the neighbourhood of the sender can't receive data and all nodes in the receiver neighbourhood can't send data.

Consequently, it is of paramount importance not only to reduce the number of hops in a path but to select nodes such that the number of impacted neighbours is as low as possible.

The number of allocated slots takes into account the number of hops. In a path, an intermediary node receives data and relays them to next hop. So, it needs to reserve slots for reception and other slots for transmission. Thus, given a flow that requires k slots, each intermediary should be allocated $2k$ slots. Source (respectively destination) node should reserve k slots for transmission (respectively for reception).

The amount of time slots allocated for flows is given by theorem 1.

Theorem 1: given a flow with k -slot requirements forwarded via a path $P = \langle v_1, \dots, v_N \rangle$, the amount of time slots allocated to such a flow is $SA(P) = 2k(N-1)$.

When a node reserves bandwidth, the higher the number of neighbors is, the lower the network throughput is. Consequently, QoS-aware routing protocols should select paths with the lowest impact on the network, thus enabling the admission of more flows and/or flows with high bandwidth requirements.

The impact of slot allocation is given by theorem 2. A time slot at a node j is impacted by a node i (which relays flow f packets) if such a slot can't be used to send or receive data to avoid interferences between nodes i and j . Let $SR(P)$ denote slots reserved for a flow f crossing path P by the number of slots impacted by the flow f . Theorem 2 gives the number of slots reserved by a flow f .

Theorem 2: given a flow with k -slot requirements forwarded via a path $P = \langle v_1, \dots, v_n \rangle$, the flow impact on the neighborhood of path P , denoted $SR(P)$, is :

$$SR(P) \leq k(N_1 - 1) + \sum_{i=2}^{n-1} 2k(N_i - 1) + k(N_n - 1)$$

where N_i is the number of neighbors of node v_i .

As shown by lemma 1, the impact of time slot allocation for a flow is derived from theorems 1 and 2. Lemma 1 provides a bound on the number of slots impacted by a flow f .

Lemma 1: given a flow with k -slot requirements forwarded via a path $P = \langle v_1, \dots, v_n \rangle$, the flow impact on the overall network, denoted $SI(P)$, is:

$$SI(P) \leq kN_1 + \sum_{i=2}^{n-1} 2kN_i + kN_n$$

4. Routing Protocol

4.1 Routing problem statement

Routing problem we are considering is denoted DBCONT (Delay and Bandwidth Constrained Optimal Network Throughput) routing.

Using Lemma 1, the optimal routing protocol which solves the DBCONT problem is defined as follows: Given a source s and destination d , the optimal routing protocol is the protocol that returns a path $P \in \pi(s, d)$ such that P meets bandwidth and delay requirements and $\forall P' \in \pi(s, d) \Rightarrow SI(P) \leq SI(P')$. $\pi(s, d)$ is the set of path between s and d .

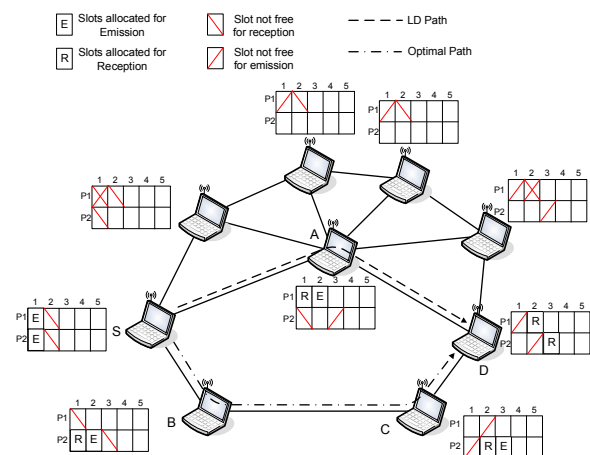

Figure 1. Impacts of paths selected by LD and optimal routing protocols

Figure 1 compares the Least Delay (LD) routing protocol to the optimal routing protocol. It considers a flow between nodes S and D that requires one time slot. The optimal routing protocol selects path P_1 whereas the LD routing protocol selects path P_2 . Using path P_1 , the number of impacted slots is 16. For path P_2 , the number of impacted slots is 14. So the optimal routing protocol yields a lower impact on the neighbourhood compared to another routing protocol.

The effectiveness of a path P may be measured by means of impacted bandwidth, denoted $BI(P)$, which represents the bandwidth made unavailable because of slot allocation impact:

$$BI(P) = \frac{1}{T} SI(P)T_s C$$

where T is the TDMA superframe duration, T_s the slot duration and C the link capacity.

4.2. Overview of proposed routing protocol

Our protocol is an extension to the well-known AODV protocol. It relies on two procedures: route discovery and route maintenance. During the route discovery, it uses a weight function to determine the best path. It is loop-free.

Route discovery and maintenance procedures use three metrics for each path: end-to-end delay and bandwidth and the number of neighbors of all the nodes included in the path. These metrics are updated according to information captured at link layer (i.e. delay, bandwidth, and neighbors of each link forming the path).

Each node maintains two tables: a routing table and a reverse routing table. Routing table keeps information to reach the destination: source node, destination node, next hop, source sequence number, bandwidth, and delay requirements. Reverse routing table keeps information to forward the route confirmation from the destination to the source: source node, destination node, source sequence number, sub-path weight and previous node.

4.3 Weight function

To enable selection of the best path, intermediate nodes compute a cost function to decrease the impact of paths on the network. Path selection must meet the delay requirements and minimize the neighbor number. To minimize the latter, the path weight function penalizes paths with higher neighbor number and lower delay and privileges paths with higher delay and lower neighbor number.

The path with the lowest weight is selected by the destination. The weight function of path P is given by the formula (1):

$$w(P) = \begin{cases} \log \left(\frac{1}{1 - \frac{D(P)}{D_{e2e} + \epsilon}} \right) \sum_{i=1}^{n-1} N_i & \text{if } D(P) < D_{e2e} + \epsilon \wedge AS(i, i+1) \geq B_{e2e} \\ \infty & \text{else} \end{cases} \quad (1)$$

where D_{e2e} is the delay constraint, $D(P)$ the path delay, $AS(i, i+1)$ the available slots on link $\langle i, i+1 \rangle$ which are the intersection between the slots available for transmission of i and the slots available for reception of $i+1$, B_{e2e} the bandwidth constraint and N_i the number of node i neighbors.

Notice that $w(P) \rightarrow \infty$ when $D(P) > D_{e2e} + \epsilon$ and $w(P) = 0$ when $D(P) = 0$.

4.4 Route construction phase

This procedure is a modification to the one used in AODV. First, new fields are added in the route request packet (RREQ): bandwidth and delay requirements, sub-path neighbor number, sub-path delay, and time slot list. Moreover, according to node position along the path, three different algorithms may be executed as explained below.

1) Source node algorithm

The source node first checks its bandwidth availability. If there are sufficient free time slots at source node, the source sends a RREQ packet. If no response is received within a fixed time, the source node resends (a maximum number of RREQ retransmission is checked before retransmitting) another RREQ packet. Upon receiving a response packet (RREP), the path is setup. Then, the source node allocates time slots before starting data packet transmission.

2) Intermediate node algorithm

Upon receiving a RREQ packet, each intermediate node forwards such a request if it meets the QoS constraints (figure 2). Intermediate node checks if the route included in the request is better than previously received request for the same couple of source and destination nodes. The node updates the reverse path and inserts its transmission-free slots and its Id in the request if the path weight (given by formula 1) is better than the already known path weight and if it has sufficient free time slots to fulfill QoS constraints included in the received request. If both checks are

positive, the modified request is broadcast. Whenever an intermediary node receives a RREP packet, it allocates time slots according to the slot list included in RREP packet, and forwards it to the previous node on the reverse path.

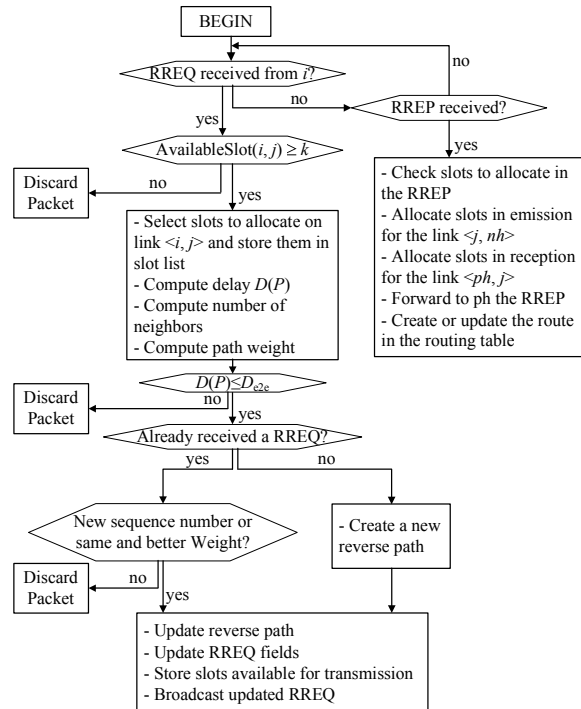

Figure 2. Intermediate node algorithm executed at node j

3) Destination node algorithm

Destination node algorithm is shown on figure 3. For each received RREQ packet, the total cost of the path is computed by the destination node. The latter maintains a timer for waiting RREQ packets. When the timer expires, the destination node selects the least-cost path. Then, it sends towards the source node a route reply packet (RREP) carrying the list of slots to reserve for the selected path.

4.5 Route maintenance

Node mobility may result in route broking, and consequently in degradation (loss) of QoS. Thus, route maintenance is of paramount importance for QoS routing in MANETs. We propose a simple route maintenance method. In case of node movement, broken route is detected by the upstream node (closer to source), e.g. assume the upstream node i sends a packet to node $i+1$. Node i will assume the route

broken if it does not hear any transmission from node $i+1$ for a certain time. If the existing QoS route is broken, the upstream node on the route will send a RERR packet to the source. When an intermediary node receives the RERR packet it releases slots allocated for the broken flow. Downstream nodes release the slots when the connection timer expires (a timer is associated with each allocated slot and it is reset each time a packet is sent). When the source receives this packet it will start a new route discovery process.

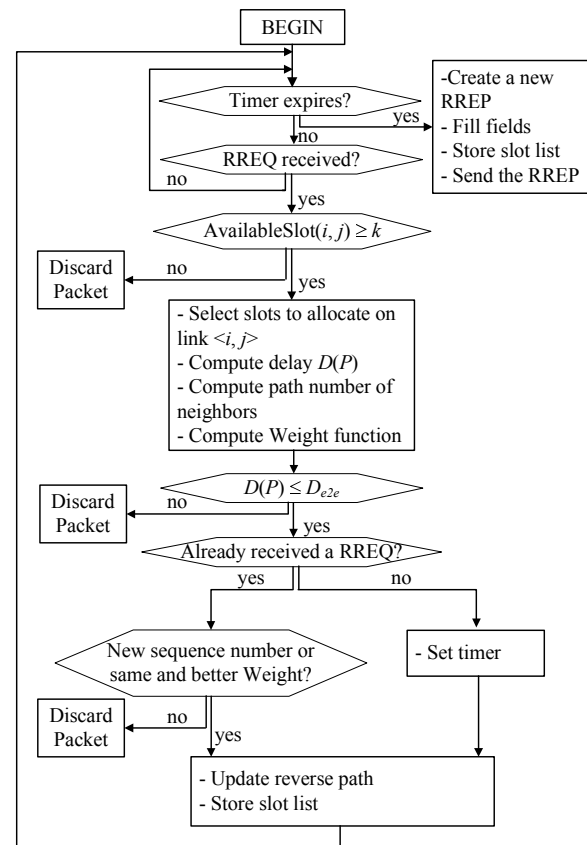

Figure 3. Destination node algorithm

5. Simulation

5.1 Simulation model

To assess the performance of our routing protocol, we conducted intensive simulation using network simulator NS-2. To analyze a realistic network model, we designed a program which randomly places M nodes on a 1000m*1000m plan.

The chosen node range is 150 meters. Link capacity is 11 Mb/s. The underlying MAC protocol is TDMA. There are 5 TDMA superframes. Each superframe is composed of 350 time slots. Each slot enables the transmission of a 500-byte packet. Since control slots are used either to send routing packets or TDMA control packets, the data slots is $350 - M$.

Simulations use a communication model in which the half of nodes establish connections with the nodes of the other half. The traffic is CBR. The data packet length is 500 bytes. Each flow requires 20 kb/s. The simulation duration is 500 sec, and the flows start randomly in $[0 .. 500 \text{ sec}]$.

For each simulation run, we use 20 snapshots composed of different topologies with their traffic patterns. The reported results are the averages of 20 snapshot results.

We compare our algorithm with QoS-AODV and AODV protocols. QoS-AODV protocol returns the lowest delay path (LD path). Nodes forward RREQ packets only if the sub-path has a better delay than the previously stored sub-path associated with the same couple of source and destination nodes.

QoS-AODV and our protocol include slot reservation mechanism. For fair comparison between our protocol and AODV (which does not assume any reservation mechanism, as it is a best effort protocol), our simulation model is based on the following: once an AODV route is found, a procedure is undertaken to reserve slots along the route. If such a procedure succeeds, the flow is started. Otherwise, the route is rejected, a new attempt is made (no more than three reservation attempts are made).

5.2 Result discussion

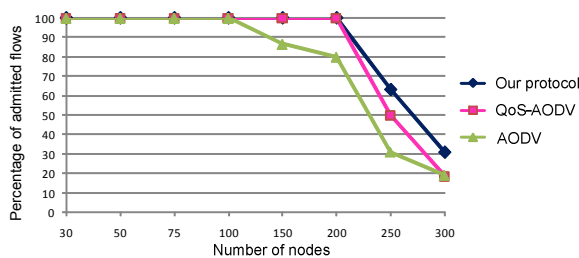

Figure 4. Percentage of admitted flows

When the number of nodes is higher than 100, AODV protocol results in more selected routes than the other protocols, because AODV does not check bandwidth availability along the selected routes. Once AODV has found a route, we use a procedure to reserve bandwidth. However, such a procedure may fail

in reserving slots on the selected route when the traffic is high. Consequently the route selected by AODV is rejected. Above 200 nodes, QoS-AODV and our protocol may fail in finding routes. However, our protocol allocates up to 20% routes more than QoS-AODV at high load. Around 300 node density, QoS-AODV and AODV experience similar performance.

Our protocol weight function is efficient since it enables to select paths with a low number of neighbor nodes. QoS-AODV protocol doesn't optimize the network throughput. It only quickly returns a path which guarantees bandwidth and delay requirements.

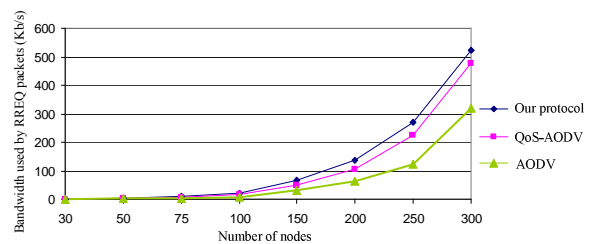

Figure 5. Routing packets sent to obtain paths

Figure 5 shows the overhead (in terms of routing packets) to obtain routes. The number of RREQ packets increases with the number of nodes of the scenario. Recall that the number of flows is the half of node number. After three failures in finding a route, the source stops sending RREQ packets. Route discovery failures increase the overhead of routing protocols because several attempts are needed to detect that no path meets QoS constraints.

More RREQ packets are sent by our protocol because its weight function takes into account not only the delay but also the number of neighbors.

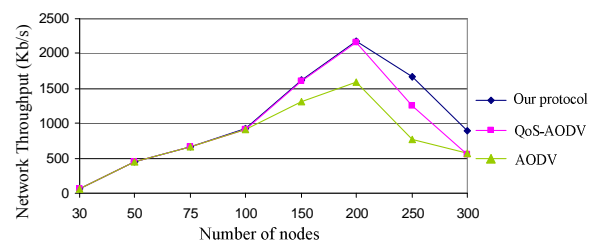

Figure 6. Network throughput

Figure 6 shows the network throughput, which is the bandwidth used by packets correctly sent.

When the number of nodes is less than 150, all flows can reserve slots. Consequently, the network throughput is the same for all the considered protocols.

When the number of nodes is greater than 100 some nodes have no available slots to establish new connections. AODV protocol returns paths but which do not meet QoS requirements because AODV does not check resource availability. In this case, AODV throughput is lower than the one of the other protocols.

Above 200 nodes, the flow number increases and thus the number of data slots decreases. For example, at 250 nodes, only 100 slots are allocated to data packets while there are 125 flows. All flows cannot meet their bandwidth requirements. In such a case, the network throughput decreases because a few flows are admitted in the network. When the network load is high, our protocol is more efficient since the bandwidth is less impacted compared to QoS-AODV. Our protocol enables more admitted flows than QoS-AODV.

6. Conclusions

In this paper, we present the importance of QoS routing in Ad hoc mobile networks, the challenges we tackle, and the approach we take. We discuss our extension to AODV protocol to provide QoS support. We propose a QoS routing protocol to be used in TDMA-based MANETs. Our protocol selects paths with a low impact on the network. Decreasing the impact (i.e. the amount of bandwidth consumed by admitted flows) of flows results in more accepted admitted flows and/or more bandwidth used by established flows.

To show the effectiveness of our protocol, we compare it to the well-known QoS-AODV and AODV protocols. From a performance point of view, our protocol has less impact on the network than the other protocols.

When the network load increases, our protocol provides a higher network throughput than other protocols. In such a case, more flows are admitted.

The improvement of network throughput comes with a cost. Our protocol has a higher overhead than QoS-AODV.

Finally, it should be noticed that our protocol is more scalable than QoS-AODV and AODV. It is particularly efficient in dense environments where MANET may be deployed.

7. References

- [1] C. Perkins, E.M. Royer, S.R. Das, "Ad Hoc On-Demand Distance Vector routing", RFC 3561, July 2003
- [2] T. Clausen and P. Jacquet, "Optimized Link State Routing Protocol", RFC 3626, October 2003.
- [3] D. Johnson, Y. Hu, D. Maltz, The Dynamic Source Routing Protocol (DSR) for Mobile Ad Hoc Networks for IPv4, RFC 4728, February 2007.
- [4] C. Perkins, E. Belding-Royer, "Quality of Service for Ad-hoc On-demand Vector Routing", IETF Draft, October 2003.
- [5] Y.-K. Ho, R.-S. Liu, "A Novel Routing Protocol for Supporting QoS for Ad Hoc Mobile Wireless Networks", Wireless Personal Communications Journal, v.22 n.3, p.359-385, 2002.
- [6] Y. Hwang, P. Varshney, "An adaptive QoS routing protocol with dispersity for ad-hoc networks". 36th Annual Hawaii International Conference on System Sciences, January 2003, pp.302-311.
- [7] T.S. Su, C.H. Lin, W. Hsieh, "A Novel QoS-Aware Routing for Ad Hoc Networks," 2006 Conference on Wireless Networks ICWN'06, June 2006, Las Vegas, USA.
- [8] Y. S. Chen et al. "An on-Demand, Link-State, Multi-Path QoS Routing in a Wireless Mobile Ad-Hoc Network", Computer communication, 27(1):27-40, Jan, 2004.
- [9] Labiod H., Quidelleur, "QoS-ASR: An Adaptive Source Routing Protocol with QoS Support in Multihop Mobile Wireless Networks". IEEE VTC'02, pp. 1978- 1982. 2002.
- [10] S. De et al., "Trigger-Based Bistributed QoS Routing in Mobile Ad Hoc Networks," ACM Mobile Computing and Communications Review, 6(3):22--35, July 2002
- [11] S. Chen, K. Nahrstedt, "Distributed Quality-of-Service Routing in Ad Hoc Networks", IEEE Journal on Selected Areas in Communications, pp. 1488-1504, August 1999.
- [12] J. Wang, Y. Tang, S. Deng, J. Chen, "QoS Routing with Mobility Prediction in MANET", IEEE Pacific Rim Conference on Communications, Computers and Signal Processing, 2001, PACRIM, pp. 357-360, August 2001.
- [13] K.H. Vik, S. Medidi, "Quality of Service aware Source Initiated Ad-Hoc Routing", 1st IEEE International Conference on Sensor and Ad hoc Communications and Networks, Santa Clara, 2004
- [14] Q. Xue, A. Ganz, "Ad hoc QoS on-Demand Routing (AQOR) in Mobile Ad Hoc Networks," Journal of Parallel and Distributed Computing, vol. 41, pp. 120-124, June 2003.
- [15] J.H. Song et al, "Load-Aware On-Demand Routing (LAOR) Protocol for Mobile Ad Hoc Networks", IEEE VTC, April 2003, pp. 1753-1757.
- [16] I. Jawhar, J. Wu, "QoS Support in TDMA-Based Mobile Ad Hoc Networks", J. Computer Science Technology, 20(6):797-810, 2005.
- [17] W.H. Liao, Y.C. Tseng, K.P. Shih, "A TDMA-Based Bandwidth Reservation Protocol for QoS Routing in a Wireless Mobile Ad Hoc Network", IEEE International Conference on Communications, 2002.

- [1] C. Perkins, E.M. Royer, S.R. Das, "Ad Hoc On-Demand