



HAL
open science

Vertex disjoint routings of cycles over tori

Jean-Claude Bermond, Min-Li Yu

► **To cite this version:**

Jean-Claude Bermond, Min-Li Yu. Vertex disjoint routings of cycles over tori. *Networks*, 2007, 49 (3), pp.217-225. <inria-00429086>

HAL Id: inria-00429086

<https://inria.hal.science/inria-00429086v1>

Submitted on 30 Oct 2009

HAL is a multi-disciplinary open access archive for the deposit and dissemination of scientific research documents, whether they are published or not. The documents may come from teaching and research institutions in France or abroad, or from public or private research centers.

L'archive ouverte pluridisciplinaire HAL, est destinée au dépôt et à la diffusion de documents scientifiques de niveau recherche, publiés ou non, émanant des établissements d'enseignement et de recherche français ou étrangers, des laboratoires publics ou privés.



HAL Authorization

Vertex Disjoint Routings of Cycles over Tori

Jean-Claude Bermond^a and Min-Li Yu^b

August 11, 2006

^a*MASCOTTE, joint project I3S-CNRS/INRIA/Université de Nice-Sophia Antipolis, 2004*

Route des Lucioles, BP93, F-06902, Sophia-Antipolis Cedex, France

email: bermond@sophia.inria.fr

^b*Dept. of Mathematics and Statistics, University College of the Fraser Valley, Abbotsford,*

B.C., Canada, V2S 4N2

email: joseph.yu@ucfv.ca

Abstract

We study the problem of designing a survivable WDM network based on covering the communication requests with subnetworks that are protected independently from each other. We consider here the case when the physical network is $T(n)$, a torus of size n by n , the subnetworks are cycles and the communication scheme is all-to-all or total exchange (where all pairs of vertices communicate). We will represent the communication requests by a logical graph: a complete graph for the scheme of all-to-all. This problem can be modeled as follows: find a cycle partition or covering of the request edges of K_{n^2} , such that for each cycle in the partition, its request edges can be routed in the physical network $T(n)$ by a set of vertex disjoint paths (equivalently, the routings with the request cycle form an elementary cycle in $T(n)$). Let the load of an edge of the WDM network be the number of paths associated with the requests using the edge. The cost of the network depends on the total load (the cost of transmission) and the maximum load (the cost of equipment). To minimize these costs, we will search for an optimal (or quasi optimal) routing satisfying the following two conditions: (a)

each request edge is routed by a shortest path over $T(n)$, and (b) the load of each physical edge resulting from the routing of all cycles of S is uniform or quasi uniform. In this paper, we find a covering or partition of the request edges of K_{n^2} into cycles with an associated optimal or quasi optimal routing such that either (1) the number of cycles of the covering is minimum, or (2) the cycles have size 3 or 4.

Keywords: WDM networks, fault tolerance, protection by cycles, torus, cycle covering.

1 Introduction

This paper is motivated by the problem of designing an optical survivable WDM network, where the protection is ensured by covering the family of communication requests by a set of cycles. The subnetworks are chosen to be cycles in order to minimize the complexity of the routing problem with full survivability. Given the failure of any single link, we can reroute the traffic going through the failed link via the other part of the cycle. (More precisely one can associate two wavelengths to each cycle of the covering: one for the normal traffic and another as a spare one.) This problem was asked by France Telecom R & D (see [3] for more details). Similar problems were also considered by several authors [6, 7, 8, 9].

We model the physical communication network by a graph, called the physical graph and denoted by G . It is a symmetric digraph, but we will see that we only need to consider the underlying undirected graph. The family of communication requests (or an instance of communications) is modeled by another graph, called the logical (or virtual or request) graph and denoted by I . The vertex set of the logical graph is the same as that of the physical graph and the edges correspond to the requests between these vertices. We will suppose that the requests are symmetric. Therefore, the logical graph will be a symmetric digraph. Routing an instance consists of associating a directed path in the physical graph G to each request (arc of I).

Finally we suppose that the routing of symmetric requests is done by symmetric routing (that is the way done in backbone networks of telephone companies). The symmetry of the routing implies that we can consider undirected graphs instead of symmetric digraphs for

both the physical and logical graphs. Therefore, routing an instance consists of associating an undirected path in the physical graph G to each (symmetric) request (edge of I). A routing is called a shortest path routing if each path in the routing is a shortest path in the physical graph G . The load of an edge of G is the number of paths of the routing which contain this edge.

The survivability problem mentioned above can be modeled by finding a cycle partition or covering of the edges of I with an associated routing over G . For the protection reason, or minimizing the damage causing by the failure of the vertices, we have an additional constraint which is defined as follows.

Definition 1.1. A routing is said to satisfy the Disjoint Routing constraint, or *DR constraint*, if the requests involved in a cycle of the covering are routed via vertex disjoint paths (equivalently, their routings form an elementary cycle in the physical graph G).

Our aim is to minimize the cost of the network. The cost function of a network is a complex function which depends on many parameters. The transmission cost depends on the total load of the network. The equipment cost (which is the most important in particular for local networks) depends on the size of the OADM (Optical Add-Drop Multiplexers) put in the vertices, which itself depends on the load of the edges linked to the vertex.

We will try to find a routing which minimizes the total load (it suffices to use a shortest path routing) and also makes the load on each edge as uniform as possible.

Definition 1.2. A routing is called *optimal* (resp. *quasi optimal*) if it satisfies the following conditions:

- (a) all paths are shortest paths,
- (b) the DR constraint is satisfied,
- (c) the load for the edges of G is uniform (resp. quasi uniform).

Remark. In some cases, it is impossible to have the same load on all edges and this happens when the total number of edges in the paths of the routing is not divisible by the number of edges in the physical graph. In this case, a uniform load means that the difference between

the maximum and minimum load is one and a quasi uniform load corresponds to a difference of two.

In summary, we are interested in finding a cycle partition of the edges of a logical graph I such that the routing associated with the requests is optimal or quasi optimal.

Two other natural optimization criteria for the problem are: (1) minimize the number of cycles in the partition (which is related to the problem of minimizing the number of wavelengths used and the cost of transmission; see the remark at the end of the section) and (2) minimize the length of the cycles (short cycles are easier to manage and in case of failures, rerouting is easier).

In [3] and [4], the case is studied when the physical graph G is C_n , a cycle of length n , and the logical graph I is K_n , which corresponds to the instance of communication called total exchange or all-to-all, where each vertex wants to communicate with all the others simultaneously. In this case, the DR constraint implies that the paths associated with the routing of a request cycle form the C_n and they give a load 1 to each edge. So all the optimization criteria are reduced to minimizing the number of cycles in the partition. We determined the minimum number of cycles needed in an optimal covering and showed that it could be realized by using only C_3 and C_4 . We also studied the case where only C_4 's are used in the covering.

In this paper, another particular case of the general problem is considered. We assume that the physical graph is a square torus $T(n)$, which can be considered as the Cartesian product of two C_n 's, and the logical graph is the complete graph K_{n^2} corresponding to all-to-all communication.

Notice that for n odd, as the degree of all vertices of K_{n^2} is even, a possible optimal solution is a cycle partition (instead of a cycle covering) which satisfies the requirements. For n even, as each degree in K_{n^2} is odd, at least $n^2/2$ edges (requests) have to be covered twice in any cycle covering of K_{n^2} . The best we can do is to have a cycle partition of $K_{n^2} + F$, where F is a 1-factor, and in this case, for minimizing the load, the edges of the 1-factor should be routed by paths of length one in $T(n)$.

The following two problems are considered:

Problem 1. Find a cycle partition (of the edges) of K_{n^2} (or $K_{n^2} + F$, where F is a 1-factor) with an associated optimal or quasi optimal routing over $T(n)$ such that the number of cycles is minimized.

Problem 2. Find a $\{C_3, C_4\}$ -cycle partition (of the edges) of K_{n^2} (or $K_{n^2} + F$, where F is a 1-factor) with an associated optimal or quasi optimal routing over $T(n)$.

Concerning Problem 1, we prove the following theorems.

Theorem A. Let n be odd. The minimum size of a cycle partition of K_{n^2} , with an associated optimal routing over $T(n)$, is exactly $n(n^2 - 1)/4$.

Theorem B. Let $n = 2k$. There exists a cycle partition of $K_{n^2} + F$, where F is a 1-factor, of size $n^3/4 + cn^2$ with an associated optimal routing over $T(n)$ when k is odd and a quasi optimal routing when k is even.

Remark: Theorem A gives an optimal solution, but Theorem B only gives a solution which is asymptotically optimal with respect to the size of the partition as a lower bound on the number of cycles is $(n^3 + 4)/4$.

Concerning Problem 2 we prove the following theorems.

Theorem C. Let n be odd. There exists a $\{C_3, C_4\}$ -partition of K_{n^2} with an associated optimal routing over $T(n)$.

Theorem D. Let $n = 2k$. There exists a $\{C_3, C_4\}$ -partition of $K_{n^2} + F$, where F is a 1-factor, with an associated optimal routing over $T(n)$ when k is odd and a quasi optimal routing when k is even.

Remark: A related problem well studied in optical networks consists of finding the minimum number of colors (wavelengths), denoted $w(G, I)$, required to color the edges of the logical graph I such that the paths associated with the requests having the same color are edge-disjoint in the physical graph G . Many results have been obtained, in particular when I is a

complete graph (all-to-all communication). For the torus, the value of $w(T(n), K_{n^2})$ has been determined to be $n(n^2 - 1)/8$ if n is odd and $n^3/8$ if n is even [1, 2, 5, 10]. When the physical graph is C_n , the problem of determining $w(C_n, I)$ is similar to that of finding a partition of I into the minimum number of cycles with a routing satisfying the DR constraint. But for the torus, these two problems are different. Indeed, if we consider the paths associated with the requests having the same color, they are edge-disjoint, not vertex disjoint. Furthermore, the solutions obtained do not consist of the union of vertex disjoint cycles. Therefore, the previous results on w can not be used here.

2 Minimum cycle covering and its routing

In this section, we prove Theorem A and Theorem B. First some notation and lemmas are introduced.

Throughout the paper, we will always assume that $V(T(n)) = V(K_{n^2}) = Z_n \times Z_n$, where Z_n is the set of integers modulo n . We will represent a vertex by its coordinates (x, y) in the Cartesian plane, $0 \leq x, y \leq n - 1$. A vertex (x, y) is adjacent to four vertices $(x, y + 1), (x, y - 1), (x + 1, y)$ and $(x - 1, y)$ in $T(n)$. An edge $(x, y)(x + 1, y)$ is called horizontal and an edge $(x, y)(x, y + 1)$ is called vertical.

We denote by $[a_1, a_2, \dots, a_k]$ and (a_1, a_2, \dots, a_k) a path of length $k - 1$ and a cycle of length k respectively. Also $[a_1, a_2, \dots, a_k] + p$ and $(a_1, a_2, \dots, a_k) + p$ are the same as $[a_1 + p, a_2 + p, \dots, a_k + p]$ and $(a_1 + p, a_2 + p, \dots, a_k + p)$, respectively. If $P_1 = [a_1, a_2, \dots, a_s]$ and $P_2 = [a_s, a_{s+1}, \dots, a_q]$ are two paths, then $\bigcup_{i=1}^2 P_i = [a_1, a_2, \dots, a_q]$ is the concatenation of the two paths. We define a vertex transformation α for $T(n)$ (or K_{n^2}) as follows:

$$\alpha((x, y)) = (n - 1 - y, x) = (-y, x) \text{ (in fact, } \alpha \text{ is the rotation by } \pi/2 \text{)}$$

This operation can be easily extended to edges: $\alpha((x_1, y_1)(x_2, y_2)) = \alpha((x_1, y_1))\alpha((x_2, y_2))$. Similarly, we can extend this operation to a path or a cycle.

Let $\rho(T(n))$ be the minimum number of cycles in a partition of K_{n^2} (when n is odd) or $K_{n^2} + F$ (when n is even and F is a 1-factor) satisfying the DR constraint (see Definition 1.1). In the rest of this section, first we derive a lower bound for $\rho(T(n))$. Then we find a cycle partition with an optimal routing over $T(n)$ which attains the lower bound if n is odd, and if n is even, a quasi optimal routing over $T(n)$ which attains the lower bound asymptotically.

Lemma 2.1: Let $n \geq 2$. Then

$$\begin{aligned}\rho(T(n)) &\geq n(n^2 - 1)/4, \text{ if } n \text{ is odd, and} \\ \rho(T(n)) &\geq (n^3 + 4)/4 \text{ if } n \text{ is even.}\end{aligned}$$

Proof: Let u and v be two vertices of a graph. We denote by $d(u, v)$ the distance or the length of a shortest path in the graph between vertices u and v . Let $u \in V(T(n))$. We define $D_u(i) = \{v \in V(T(n)) : d(u, v) = i\}$. Hence $D_u(i) \cap D_u(j) = \emptyset$ if $i \neq j$.

Let $n = 2k + 1$. It is clear that $|D_u(i)| = 4i$ if $1 \leq i \leq k$ and $|D_u(i)| = 4(2k + 1 - i)$ if $k + 1 \leq i \leq 2k$. So $|D_u(i)| = |D_u(2k + 1 - i)| = 4i$. The sum of the total distances between any two vertices of $T(n)$ can be computed as follows:

$$\begin{aligned}\sum_{u,v} d(u, v) &= (n^2/2) \sum_v d(u, v) \\ &= (n^2/2) \sum_{i=1}^{2k} i |D_u(i)| \\ &= (n^2/2)(2k + 1) \sum_{i=1}^k 4i \\ &= (n^2/2)(2k + 1)4(1 + 2 + \dots + k) = n^3(n^2 - 1)/4.\end{aligned}$$

One of our aims is to minimize the number of cycles in the covering of K_{n^2} . For each cycle of the covering, the sum of the distances of the requests of each cycle is at most n^2 as the paths of the associated routing are vertex disjoint. Therefore, these paths will use at most n^2 edges of $T(n)$. Hence, we have the lower bound for the size of the cycle covering: $\rho(T(n)) \geq n(n^2 - 1)/4$. Note that this constraint also implies the degree constraint: $\rho(T(n)) \geq (n^2 - 1)/2$.

Let $n = 2k$ and $u \in V(T(n))$. Then $|D_u(i)| = 4i$ if $1 \leq i \leq k - 1$, $|D_u(k)| = 4k - 2$, $|D_u(i)| = 4(2k - i)$ if $k + 1 \leq i \leq 2k - 1$ and $|D_u(2k)| = 1$. The sum of the total distances in $T(n)$ is

$$\begin{aligned}
\sum_{u,v} d(u,v) &= (n^2/2) \sum_{i=1}^{2k} i |D_u(i)| \\
&= (n^2/2)[8k(1+2+\dots+k-1) + k(4k-2) + 2k] \\
&= 4k^3n^2/2 = n^5/4
\end{aligned}$$

Recall that $n^2/2$ request edges have to be covered twice and each of the associated routings is a path of length at least one. Hence, at least $n^5/4 + n^2/2$ distances need to be covered by the requests in K_{n^2} . By the same argument as before, the routing of each cycle will use up to n^2 edges in $T(n)$. Therefore the lower bound in this case is $(n^3 + 2)/4$. \square

We next show that when n is odd, the lower bound can be attained with an optimal routing.

Proof of Theorem A: Let $n = 2k + 1$. We first remark that if the above bound is attained, then for each cycle of the covering of K_{n^2} , the sum of the distances covered by the routing (that is, the sum of the lengths of the paths used in the routing) in $T(n)$ is n^2 . Therefore, the routing of the cycle is an Hamilton cycle of $T(n)$.

We partition the edge set of K_{n^2} into $2k(k+1)$ sets as follows:

$$\begin{aligned}
A_{i,j} &= \{(x,y)(x+i,y+j) : (x,y) \in T(n)\}, \text{ where } 0 \leq i \leq k \text{ and } 1 \leq j \leq k, \text{ and} \\
A'_{i,j} &= \{(x,y)(x+i,y-j) : (x,y) \in T(n)\}, \text{ where } 1 \leq i \leq k \text{ and } 0 \leq j \leq k.
\end{aligned}$$

It is clear that these sets are disjoint, each set contains exactly n^2 edges and these sets form a partition of the edge set of K_{n^2} . Notice that if $e \in A_{i,j}$, then $\alpha(e) \in A'_{j,i}$ and $\alpha(A_{i,j}) = A'_{j,i}$.

The following lemma will allow us to pair two $A_{s,t}$'s (and, by rotation, two $A'_{s,t}$) such that their edges can be partitioned into cycles.

Lemma 2.2. For $0 \leq s \leq k$, $1 \leq t \leq k$, let $C_{s,t} = A_{s,t} \cup A_{k-s,k+1-t}$. The edges of $C_{s,t}$ can be partitioned into n $2n$ -cycles with a shortest path routing giving a load of k on the horizontal edges and $k+1$ on the vertical edges of $T(n)$.

Proof. Each set $C_{s,t}$ can be partitioned into n $2n$ -cycles as follows:

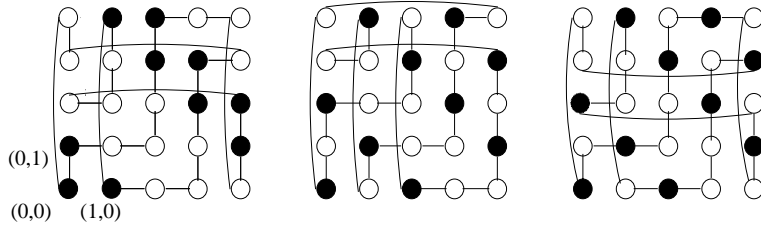

Figure 1: $R_{0,1,0}$, $R_{0,2,0}$ and $R_{1,1,0}$ over $T(5)$.

$$C_{s,t,x} = \bigcup_{i=0}^{n-1} [(x, 0), (x + s, t), (x + k, k + 1)] + i(k, k + 1),$$

where $0 \leq x \leq n - 1$.

Notice that each cycle here is obtained by concatenating n paths of length two. It is easy to check that the $C_{s,t,x}$'s are edge disjoint as k and $k + 1$ are relatively prime.

For each $C_{s,t,x}$, we associate the routing

$$R_{s,t,x} = \bigcup_{i=0}^{n-1} \{[(x, 0), (x, 1), \dots, (x, t), (x + 1, t), \dots, (x + s, t)], \\ [(x + s, t), (x + s + 1, t), \dots, (x + k, t), (x + k, t + 1), \dots, (x + k, k + 1)]\} + i(k, k + 1)$$

See Figure 1 for the routings $R_{0,1,0}$, $R_{0,2,0}$, $R_{1,1,0}$ over $T(5)$ (the corresponding cycles are those formed by the black vertices over the routings).

The routings defined above are shortest path routings. Furthermore, the routings associated with the $2n$ edges (requests) of the cycle $C_{s,t,x}$ are vertex disjoint. In fact, $R_{s,t,x}$ is a Hamilton cycle of $T(n)$.

The routings corresponding to the n cycles $C_{s,t,x}$ give a load k to the horizontal edges and $k + 1$ to the vertical ones. \square

Let s and t be given. Let $C'_{s,t,x} = \alpha(C_{s,t,x})$ with the routings $R'_{s,t,x} = \alpha(R_{s,t,x})$. We can partition the edges of $C'_{s,t}$ into n $2n$ -cycles with a load $k + 1$ on the horizontal edges and k on the vertical ones. So $C_{s,t} \cup C'_{s,t}$ can be partitioned into $2n$ $2n$ -cycles with a uniform load $k + k + 1 = 2k + 1$ on each edge.

To complete the proof, it suffices to note that the edge set of K_{n^2} can be partitioned into $(k^2 + k)/2 = (n^2 - 1)/8$ sets, namely $C_{s,t}, C'_{s,t}$ with $0 \leq s \leq \lfloor (k-1)/2 \rfloor$ and $1 \leq t \leq k$, plus if k is even, $s = k/2$ and $1 \leq t \leq k/2$. So we obtain a partition of $2n(n^2 - 1)/8 = n(n^2 - 1)/4$ cycles with a uniform load on each edge of $n(n^2 - 1)/8$. \square

Now for the rest of the section, we assume that $n = 2k$. We give an asymptotic solution with an optimal routing for k odd, and a quasi optimal routing for k even.

Proof of Theorem B: Let $n = 2k$. We note that some of the $A_{i,j}$ and $A'_{i,j}$ are identical in this case, namely, $A'_{k,s} = A_{k,s}$ and $A'_{s,k} = A_{s,k}$. Here we will use the sets $A_{i,j}$ for $0 \leq i \leq k-1$, $1 \leq j \leq k$, $A_{k,k}$ and $A'_{i,j}$, for $1 \leq i \leq k$, $0 \leq j \leq k-1$. So we have only $2k^2 + 1$ sets, 3 sets of size $n^2/2$ ($A_{0,k}$, $A'_{k,0}$ and $A_{k,k}$) and $2k^2 - 2$ sets of size n^2 , and so altogether the $n^2(n^2 - 1)/2$ edges.

The idea of the proof is similar to that of the odd case. If k is even, we can use the fact that $k-1$ and $k+1$ are relatively prime to each other, but for k odd, this will not be the case. Furthermore, we have to use an extra 1-factor of K_{n^2} and altogether we obtain a quasi optimal solution. We define a 1-factor F for this use. Let $F = \{(2p, q)(2p+1, q) : 0 \leq p \leq k-1, 0 \leq q \leq 2k-1\}$ if k is even, and $F = \{(2p, q_1)(2p+1, q_1), (2p+1, q_2)(2p+2, q_2) : 0 \leq p \leq k-1, 0 \leq q_1 \leq k-1, k \leq q_2 \leq 2k-1\}$ if k is odd.

First we deal with $A_{k,k} \cup F \cup A_{0,k} \cup A'_{k,0}$ in the following lemma which will be used also in the next section.

Lemma 2.3. The edge set $A_{k,k} \cup F \cup A_{0,k} \cup A'_{k,0}$ can be partitioned into $n^2/2$ cycles. Furthermore, there exists a shortest path routing for the cycles such that the load on each edge is uniform if k is odd and quasi uniform if k is even.

Proof. We partition the edges in $A_{k,k} \cup F$ and $A_{0,k} \cup A'_{k,0}$ into 4-cycles as follows.

For $0 \leq p \leq k-1$ and $0 \leq q \leq k-1$:

$$C_{p,q} = ((0, 0), (k, k), (k+1, k), (1, 0)) + (2p, q)$$

$$B_{p,q} = ((0, 0), (k, 0), (k, k), (0, k)) + (p, q)$$

In order to balance the load, we choose the following routings for the above cycles.

For $0 \leq p \leq k - 1$ and $0 \leq q \leq k - 1$:

$$RC_{p,q} = \{[(0, 0), (0, 1), \dots, (0, k), (1, k), \dots, (k, k)], \\ [(k, k), (k + 1, k)], \\ [(k + 1, k), (k + 1, k - 1), \dots, (k + 1, 0), (k, 0), \dots, (1, 0)], \\ [(1, 0), (0, 0)]\} + (2p, q).$$

For $0 \leq p \leq \lceil k/2 \rceil - 1$ and $0 \leq q \leq k - 1$:

$$RB_{2p,q} = \{[(0, 0), (2k - 1, 0), \dots, (k + 1, 0), (k, 0)], \\ [(k, 0), (k, 2k - 1), \dots, (k, k)], \\ [(k, k), (k + 1, k), \dots, (0, k)] \\ [(0, k), (0, k + 1), \dots, (0, 2k - 1), (0, 0)]\} + (2p, q)$$

For $0 \leq p \leq \lfloor k/2 \rfloor - 1$ and $0 \leq q \leq k - 1$:

$$RB_{2p+1,q} = \{[(1, 0), (2, 0), \dots, (k + 1, 0)], \\ [(k + 1, 0), (k + 1, 2k - 1), \dots, (k + 1, k)], \\ [(k + 1, k), (k, k), \dots, (1, k)], \\ [(1, k), (1, k + 1), \dots, (1, 0)]\} + (2p, q)$$

With the above routings, the load on the vertical edges is k . For the horizontal edges, if k is odd, the load is k on the edges $(2r, x)(2r + 1, x)$, where $0 \leq r \leq k - 1$, and $k + 1$ on the rest; if k is even, the load is $k + 2$ on the edges $(2r, x)(2r + 1, x)$, where $k/2 \leq r \leq k - 1$, and k otherwise.

Note that by a counting argument, it is not possible to have the same load on every edge in this case (recall that the routing consists only of shortest paths). Therefore, when k is odd, the load of the routing is uniform and when k is even, it is quasi uniform. \square

Lemma 2.4. $A_{k-1,1} \cup A'_{1,k-1}$ can be partitioned into $2n$ n -cycles with a uniform load k on the edges.

Proof. We partition $A_{s,1}$ into n n -cycles and associate the routings with them as follows:

For $0 \leq x \leq n - 1$:

$$C_{s,x} = \bigcup_{j=0}^{n-1} [(x, 0), (x + s, 1)] + j(s, 1)$$

$$R_{s,x} = \bigcup_{j=0}^{n-1} \{[(x, 0), (x, 1), (x + 1, 1), \dots, (x + s, 1)] + j(s, 1)\}$$

The resulting load from this set of routings is s for all horizontal edges and 1 for all vertical edges.

Now we consider $A'_{1,s}$. As $A'_{1,s} = \alpha(A_{s,1})$, we partition $A'_{1,s}$ by letting $C'_{s,x} = \alpha(C_{s,x})$ and associate $R'_{s,x} = \alpha(R_{s,x})$ as the corresponding routing. Then this gives a load 1 to the horizontal edges and s to the horizontal edges.

Therefore, in total, we have $2n$ n -cycles and the associated routing gives a uniform load $s + 1$ to each edge of $T(n)$. \square

Now we divide the rest of the proof of Theorem B into two cases.

Case 1: $n = 2k$ and k is even.

Lemma 2.5. For $0 \leq s \leq k/2 - 1$, $1 \leq t \leq k$, except $(s, t) = (0, k)$, the edges of $C_{s,t} = A_{s,t} \cup A_{k-1-s, k+1-t}$ can be partitioned into n $2n$ -cycles with a routing giving a load of $k - 1$ on the horizontal edges and $k + 1$ on the vertical ones.

Proof. We partition $A_{s,t} \cup A_{k-s-1, k-t+1}$ into n $2n$ -cycles and associate routings with them as follows.

For $0 \leq x \leq n - 1$:

$$C_{s,t,x} = \bigcup_{j=0}^{n-1} [(x, 0), (x + s, t), (x + k - 1, k + 1)] + j(k - 1, k + 1),$$

$$R_{s,t,x} = \bigcup_{j=0}^{n-1} \{[(x, 0), (x, 1), \dots, (x, t), (x + 1, t), \dots, (x + s, t)], [(x + s, t), (x + s + 1, t), \dots, (x + k - 1, t), (x + k - 1, t + 1), \dots, (x + k - 1, k + 1)]\} + j(k - 1, k + 1)$$

To finish case 1, let $C'_{s,t,x} = \alpha(C_{s,t,x})$, $R'_{s,t,x} = \alpha(R_{s,t,x})$ and $C'_{s,t} = \alpha(C_{s,t})$. Then $C_{s,t} \cup C'_{s,t}$ can be partitioned into $2n$ $2n$ -cycles with a uniform load of $2k$.

Note that the edge set of K_{n^2} , except those edges in $A_{0,k}$, $A'_{k,0}$, $A_{k-1,1}$, $A'_{1,k-1}$ and $A_{k,k}$, can be partitioned into $k^2/2 - 1$ sets, namely, $C_{s,t} \cup C'_{s,t}$ with $0 \leq s \leq k/2 - 1$ and $1 \leq t \leq k$ except $(s,t) = (0,k)$. Altogether we have $2n(k^2/2 - 1) = n^3/4 - 2n$ cycles plus the $n^2/2$ cycles of the partition of $A_{k,k} \cup F \cup A_{0,k} \cup A'_{k,0}$, and $2n$ n -cycles from $A_{k-1,1} \cup A'_{1,k-1}$, giving $n^3/4 + n^2/2$ cycles.

Case 2. $n = 2k$ and k is odd. We first prove a lemma similar to Lemma 2.5.

Lemma 2.6. For $0 \leq s \leq (k-3)/2$, $2 \leq t \leq k$, except $(s,t) = (0,k)$, the edges of $C_{s,t} = A_{s,t} \cup A_{k-2-s,k+2-t}$ can be partitioned into n $2n$ -cycles with an associated routing giving a load of $k-2$ on the horizontal edges and $k+2$ on the vertical ones.

Proof. Consider $C_{s,t} = A_{s,t} \cup A_{k-2-s,k+2-t}$. We partition this set into n $2n$ -cycles as following.

For $0 \leq x \leq n-1$:

$$C_{s,t,x} = \bigcup_{j=0}^{n-1} [(x,0), (x+s,t), (x+k-2, k+2)] + j(k-2, k+2),$$

$$R_{s,t,x} = \bigcup_{j=0}^{n-1} \{[(x,0), (x,1), \dots, (x,t), (x+1,t), \dots, (x+s,t)],$$

$$[(x+s,t), (x+s+1,t), \dots, (x+k-2,t), (x+k-2,t+1), \dots, (x+k-2, k+2)]\} + j(k-2, k+2)$$

Let $C'_{s,t,x} = \alpha(C_{s,t,x})$, $R'_{s,t,x} = \alpha(R_{s,t,x})$ and $C'_{s,t} = \alpha(C_{s,t})$. Then $C_{s,t} \cup C'_{s,t}$ can be partitioned into $2n$ $2n$ -cycles with a uniform load of $2k$. \square

In this case, $C_{s,t} \cup C'_{s,t}$, where $C'_{s,t} = \alpha(C_{s,t})$, with $0 \leq s \leq (k-3)/2$ and $2 \leq t \leq k$, except $(s,t) = (0,k)$, covers all the edges of K_{n^2} except those of $A_{k,k}$, $A_{0,k} \cup A'_{k,0}$, $A_{k-2,2} \cup A'_{2,k-2}$, $\bigcup_{i=0}^{k-1} A_{i,1} \cup A'_{1,i}$ and $\bigcup_{i=2}^k A_{k-1,i} \cup A'_{i,k-1}$. Now $A_{k,k}$, $A_{0,k} \cup A'_{k,0}$ and F can be dealt by Lemma 2.3. For the others, we will need some more lemmas.

Lemma 2.7. For $2 \leq s \leq k$, $0 \leq t \leq (k-3)/2$, except $(s,t) = (k,0)$, the edges of $A_{s,t} \cup A_{k+2-s,k-2-t}$ can be partitioned into n $2n$ -cycles.

Proof. The proof is similar to Lemma 2.6 by exchanging the vertical edges and horizontal edges. \square

Lemma 2.8. For $0 \leq s \leq (k-1)/2$, $1 \leq t \leq k$, except $(s, t) = (0, k)$ or $((k-1)/2, (k+1)/2)$, the edges of $A_{s,t} \cup A_{k-1-s, k+1-t}$ can be partitioned into $2n$ n -cycles.

Proof. The proof is similar to Lemma 2.6. However, as 2 divides both $k-1$ and $k+1$ in this case, we obtain only n -cycles.

For $0 \leq x \leq n-1$:

$$C_{s,t,x}^1 = \bigcup_{j=0}^{k-1} [(x, 0), (x+s, t), (x+k-1, k+1)] + j(k-1, k+1)$$

$$C_{s,t,x}^2 = C_{s,t,x} + (0, 1) \text{ and}$$

$$R_{s,t,x}^1 = \bigcup_{j=0}^{n-1} \{[(x, 0), (x, 1) \dots (x, t)(x+1, t) \dots (x+s, t)],$$

$$[(x+s, t)(x+s+1, t) \dots (x+k-1, t)(x+k-1, t+1) \dots (x+k-1, k+1)]\} + j(k-1, k+1)$$

$$R_{s,t,x}^2 = R_{s,t,x}^1 + (0, 1). \quad \square$$

Similarly we have the following result.

Lemma 2.9. For $1 \leq s \leq k$, $0 \leq t \leq (k-1)/2$, except $(s, t) = (k, 0)$ or $((k+1)/2, (k-1)/2)$, the edges of $A_{s,t} \cup A_{k+1-s, k-1-t}$ can be partitioned into $2n$ n -cycles.

Proof. The proof is similar to Lemma 2.8 by exchanging the vertical edges and horizontal edges.

Now we will use these lemmas to deal with the edges of K_{n^2} which are not covered by the general construction $(C_{s,t} \cup C'_{s,t})$. For example, $A_{k-1, k-2}$ can be paired by Lemma 2.9 with $A_{2,1}$ to be decomposed into n -cycles. $A_{k-1, k-3}$ can be paired with $A_{3,1}$ by Lemma 2.7 to be decomposed into $2n$ -cycles. $A_{k-1, k}$ can be paired with $A_{0,1}$ by Lemma 2.8. For the other cases, we have to delete some of the pairs used in the general construction and then use them differently. For example, $A_{k-1, k-4}$ can be paired by Lemma 2.7 with $A_{3,2}$. If we delete the set $C_{3,2}$, we can re-use $A_{k-5, k}$ (previously paired with $A_{3,2}$ by Lemma 2.6) and pair it with $A_{4,1}$ by Lemma 2.8.

In general, to deal with $A_{k-1, k-4p-\alpha}$ (with p such that $k-4p-\alpha > 1$ and $\alpha = 0, 1, 2, 3$), we add the pairings for $i = 0, 1, \dots, p-1$, $A_{k-1-4i, k+4i-4p-\alpha}$ and $A_{3+4i, 4p-4i+\alpha-2}$ by Lemma 2.7, and delete $A_{3+4i, 4p-4i+\alpha-2}$ and $A_{k-1-4(i+1), k+4(i+1)-4p-\alpha}$ used in Lemma 2.6.

Then it remains to match $A_{k-1-4p,k-\alpha}$ with

if $\alpha = 2$, $A_{4p+2,1}$ by Lemma 2.9

if $\alpha = 3$, $A_{4p+3,1}$ by Lemma 2.7

if $\alpha = 0$, $A_{4p,1}$ by Lemma 2.8

if $\alpha = 1$, $A_{4p,2}$ by Lemma 2.8, then delete the pair $A_{4p,2}$ and $A_{k-2-4p,k}$ used with Lemma 2.6 and add the pair $A_{k-2-4p,k}$ and $A_{4p+1,1}$ by Lemma 2.8.

Doing so we have paired all $A_{k-1,i}$ for $2 \leq i \leq k$ and all $A_{i,1}$ for $0 \leq i \leq k-2$. It remains to deal with $A_{k-1,1}$ and $A'_{1,k-1}$, but Lemma 2.4 can be used here.

To finish case 2, we count the number of cycles in the partition obtained. In the above regrouping steps, we use n extra cycles each time when we use Lemmas 2.8 and 2.9 which never happens for $\alpha = 3$, happens once for $\alpha = 0, 2$ and twice for $\alpha = 1$. Altogether we use $(k-2)n$ (about $n^2/2$) cycles. Therefore, we have $n^3/4 + c(n^2)$ cycles in this case. Hence, the size of the partition meets the lower bound asymptotically. \square

Remark: By choosing the 1-factor F differently, we can have a cycle partition with an associated routing where the difference between the maximum and minimum loads is 1. However the edges of F will need longer paths to route. Recall that in the above construction the edges in F are all routed by paths of length one which is optimal; by a counting argument, it is impossible to achieve the same load for all edges.

3 Small cycle covering and its routing

In this section, we will prove Theorem C and Theorem D.

Proof of Theorem C: Let $n = 2k + 1$. We define $A_{i,j}$ and $A'_{i,j}$ as in Theorem A in the last section, but define some new sets from these sets as follows.

Let $B_i = A'_{i,0} \cup A_{0,i}$, $C_i = A_{i,i} \cup A'_{i,i}$ and $D_{\{i,j\}} = A_{i,j} \cup A_{j,i} \cup A'_{i,j} \cup A'_{j,i}$, where $1 \leq i \neq j \leq k$.

Note that $D_{\{i,j\}} = D_{\{j,i\}}$ with $1 \leq i < j \leq k$, from the set notation. Hence the B_i 's, C_i 's and $D_{\{i,j\}}$'s form a partition of the edge set of K_{n^2} .

We remark that $\alpha(A_{i,j}) = A'_{j,i}$.

Lemma 3.1: Let $n = 2k + 1$. The following edge sets can be partitioned into $2n^2$ C_3 's or C_4 's:

- (1) $D_{\{i,j\}} \cup D_{\{i,r\}}$,
- (2) $C_i \cup C_j \cup D_{\{i,j\}}$,
- (3) $B_p \cup B_q \cup D_{\{i,j\}}$ with $p + q = 2i$ or $p + q = 2j$,
- (4) $B_p \cup B_q \cup B_r$ with $p + q + r = n$, where p, q, r are distinct,
- (5) $B_{2i} \cup D_{\{i,j\}}$, and
- (6) $C_p \cup D_{\{i,j\}}$ and $C_i \cup D_{\{j,p\}}$ with $i + j = p$.

Furthermore, in each case there exists a shortest path routing over $T(n)$ and the resulting load is uniform.

Proof. We give a proof in detail for (1) only and for the rest, we will give the cycles and show the figures of the corresponding routings as they are very similar to (1). For (1),(2) and (3), the sets are partitioned into 4-cycles and for (4), (5) and (6), the sets are partitioned into 3-cycles.

(1) For $0 \leq x, y \leq n - 1$ (and for fixed i, j and r):

let $C_{x,y} = ((x, y), (x + i, y + j), (x + 2i, y), (x + i, y - r), (x, y))$

and $C'_{x,y} = \alpha(C_{x,y}) = ((-y, x), (-y - j, x + i), (-y, x + 2i), (-y + r, x + i), (-y, x))$.

Let the corresponding routing be

$$\begin{aligned}
R_{x,y} = & \{[(x, y), (x, y + 1), \dots, (x, y + j), (x + 1, y + j), \dots, (x + i, y + j)], \\
& [(x + i, y + j), (x + i + 1, y + j), \dots, (x + 2i, y + j), (x + 2i, y + j - 1), \dots, (x + 2i, y)], \\
& [(x + 2i, y), (x + 2i, y - 1), \dots, (x + 2i, y - r), (x + 2i - 1, y - r), \dots, (x + i, y - r)], \\
& [(x + i, y - r), (x + i - 1, y - r), \dots, (x, y - r), (x, y - r + 1), \dots, (x, y)]\}
\end{aligned}$$

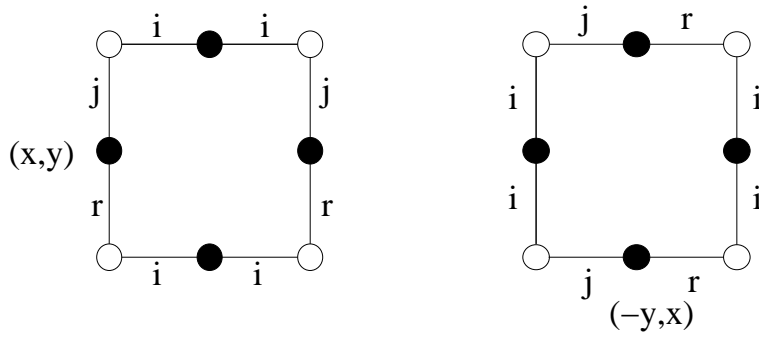

Figure 2: $R_{x,y}$ and $R'_{x,y}$ for case 1.

and $R'_{x,y} = \alpha(R_{x,y})$ (see Figure 2).

Note that the labels in the figures are the distances for the corresponding paths in the routings which are also shortest path routings.

The cycles $C_{x,y}$, $0 \leq x, y \leq n-1$, form a partition of $A_{i,j} \cup A'_{i,j} \cup A_{i,r} \cup A'_{i,r}$ and the cycles $C'_{x,y}$, $0 \leq x, y \leq n-1$, form a partition of $A_{j,i} \cup A'_{j,i} \cup A_{r,i} \cup A'_{r,i}$. Hence we have a cycle partition of $D_{\{i,j\}} \cup D_{\{i,r\}}$.

In $T(n)$, the $R_{x,y}$, $0 \leq x, y \leq n-1$, contribute $4i$ to the load of each horizontal edge and $2(j+r)$ to the load of each vertical edge, and the $R'_{x,y}$, $0 \leq x, y \leq n-1$, contribute (by rotation) $2(j+r)$ and $4i$ to the load of each horizontal and vertical edge, respectively. Altogether, the routings corresponding to the $2n^2$ 4-cycles contribute a load of $2(2i+j+r)$ to each edge of $T(n)$.

- (2) Let $C_{x,y} = ((x, y), (x+i, y+i), (x+i+j, y), (x+i, y-j), (x, y))$,
and $C'_{x,y} = ((-y, x), (-y-i, x+i), (-y, x+i+j), (-y+j, x+i), (-y, x))$.

The corresponding routings are shown in Figure 3.

For parts (3), (4), (5) and (6), we only give in Figure 4 the basic cycles and the routings corresponding to $C_{x,y}$ as the routings corresponding to $C'_{x,y}$ are just the transformation of $C_{x,y}$ under α .

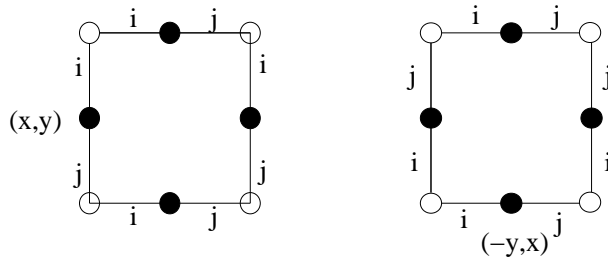

Figure 3: $R_{x,y}$ and $R'_{x,y}$ for case 2.

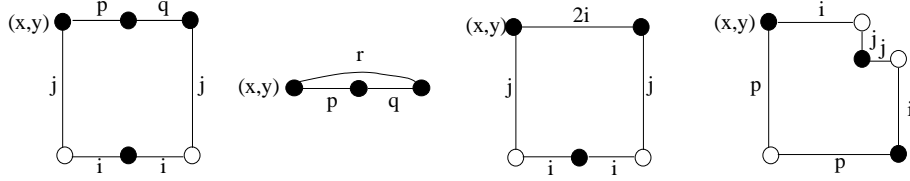

Figure 4: $R_{x,y}$ for cases 3, 4, 5 and 6.

(3) Assume $p + q = 2i$. Let $C_{x,y} = ((x, y), (x + p, y), (x + p + q, y), (x + i, y - j), (x, y))$ and $C'_{x,y} = \alpha(C_{x,y})$.

For $p + q = 2j$, we just change i to j in the above.

(4) Let $C_{x,y} = ((x, y), (x + p, y), (x + p + q, y), (x, y))$ (as $p + q > r$, the routing will be formed by shortest paths) and $C'_{x,y} = \alpha(C_{x,y})$.

(5) Let $C_{x,y} = ((x, y), (x + 2i, y), (x + i, y - j), (x, y))$ and $C'_{x,y} = \alpha(C_{x,y})$

(6) Let $C_{x,y} = ((x, y), (x + i, y - j), (x + p, y - p), (x, y))$ and $C'_{x,y} = \alpha(C_{x,y})$.

Similarly, the result is true for $C_i \cup D_{\{j,p\}}$. \square

Now we are able to prove Theorem C. Recall that $n = 2k + 1$.

Case 1: k is even. Assume $k = 4h$ or $4h + 2$. First we group the following edge sets:

$$B_{4q+1} \cup B_{4q+3} \cup D_{\{2,4q+2\}}, 1 \leq q \leq h - 1$$

$$B_{4q+2} \cup B_{4q+4} \cup D_{\{2,4q+3\}}, 1 \leq q \leq h - 1$$

$$C_{2p+1} \cup C_{2p+2} \cup D_{\{2p+1,2p+2\}}, 0 \leq p \leq 2h - 1$$

If $k = 4h$, we add $B_1 \cup B_3 \cup D_{\{2,4h\}}$ and $B_2 \cup B_4 \cup D_{\{2,3\}}$.

If $k = 4h + 2$, we add $B_{4h+2} \cup B_{4h+1} \cup B_2$, $B_1 \cup B_3 \cup D_{\{2,4h+2\}}$, $B_4 \cup D_{\{2,3\}}$
 $C_{4h+1} \cup D_{\{1,4h\}}$ and $C_{4h+2} \cup D_{\{1,4h+1\}}$.

By Lemma 3.1, these sets can be partitioned into either 3-cycles or 4-cycles.

We now show that the remaining $D_{\{i,j\}}$'s can be grouped by pairs which can be dealt with using Lemma 3.1(1). It suffices to show that for a given i , there are an even number of $D_{\{i,j\}}$'s with $i < j$ (or an even number of j values).

If $i = 1$, for $k = 4h$, there are $4h - 2$ j values as $3 \leq j \leq k$, and for $k = 4h + 2$, there are $4h - 2$ j 's as $3 \leq j \leq k - 3$ and $j = 4h + 2$.

If i is odd and $i \geq 3$, there are $k - i - 1$ j 's as $i + 2 \leq j \leq k$. It is clear that $k - i - 1$ is even as k is even and i is odd.

If $i = 2$, $j = 4q, 4q + 1$, where $1 \leq q \leq h - 1$ if $k = 4h$, and where $1 \leq q \leq h$ if $k = 4h + 2$.

If $i > 2$ and even, there are $k - i$ j values, namely those with $i + 1 \leq j \leq k$ and it is clear that $k - i$ is even here.

In each case, the number of j values for a given i is even, and we can do the pairings and decompositions using Lemma 3.1(1).

Case 2. k is odd. Let $k = 4h + 1$ ($h \geq 2$) or $4h + 3$ ($h \geq 1$). In both cases, we group the sets as follows:

$$B_{4q} \cup B_{4q+2} \cup D_{\{2,4q+1\}}, \text{ where } 2 \leq q \leq \lfloor (k-2)/4 \rfloor$$

$$B_{4q+1} \cup B_{4q+3} \cup D_{\{2,4q+2\}}, \text{ where } 2 \leq q \leq \lfloor (k-2)/4 \rfloor$$

$$C_{2p} \cup C_{2p+1} \cup D_{2p,2p+1}, \text{ where } 4 \leq p \leq \lfloor k/2 \rfloor$$

For $k = 4h + 1$, we also add:

$$B_2 \cup B_{4h} \cup B_{4h+1}$$

$$B_1 \cup B_3 \cup D_{2,4h+1}, B_4 \cup B_6 \cup D_{\{4,5\}}, B_5 \cup B_7 \cup D_{\{2,6\}}$$

$$C_3 \cup D_{\{1,2\}}, C_1 \cup C_4 \cup D_{\{1,4\}}, C_2 \cup C_5 \cup D_{\{2,5\}}, C_6 \cup C_7 \cup D_{\{6,7\}}$$

For $k = 4h + 3$, we add:

$$B_2 \cup D_{\{1,4\}},$$

$$B_1 \cup B_3 \cup D_{\{2,4h+3\}}, B_4 \cup B_6 \cup D_{\{4,5\}}, B_5 \cup B_7 \cup D_{\{6,7\}},$$

$$C_3 \cup D_{\{1,2\}}, C_4 \cup D_{\{1,3\}}, C_7 \cup D_{\{2,5\}}, C_1 \cup C_5 \cup D_{\{1,5\}}, C_2 \cup C_6 \cup D_{\{2,6\}}.$$

When k is even, we can check that for each fixed i , the number of remaining $D_{\{i,j\}}$'s is even. Then we use Lemma 3.1(1) to partition them into 4-cycles.

Now we deal with the cases when $k = 3, 5$.

When $k = 3$, we apply Lemma 3.1 to $B_1 \cup B_3 \cup D_{\{2,3\}}$ and $C_1 \cup C_3 \cup D_{\{1,3\}}$ and decompose $B_2 \cup C_2 \cup D_{\{1,2\}}$ into 3-cycles as follows:

$$\text{For } 0 \leq x, y \leq n-1, ((x, y), (x+1, y+2), (x+2, y), (x+2, y-2), (x, y)).$$

It is easy to see that we can attach shortest path routings to these cycles.

When $k = 5$, we use $B_2 \cup B_4 \cup B_5$, $B_1 \cup B_3 \cup D_{\{2,3\}}$, $C_1 \cup C_4 \cup D_{\{1,4\}}$,

and $C_2 \cup C_5 \cup D_{\{2,5\}}$, $C_3 \cup D_{\{1,2\}}$, $D_{\{1,3\}} \cup D_{\{1,5\}}$, $D_{\{2,4\}} \cup D_{\{3,4\}}$, $D_{\{3,5\}} \cup D_{\{4,5\}}$.

Therefore, when n is odd, we have a partition of the edges (requests) into small cycles and the associated routings are formed by shortest paths, where the load on the edges of $T(n)$ is uniform. \square

In the case of n even, it is clear that K_{n^2} can not be partitioned into cycles as the degree of each vertex is odd. Instead, we will consider $K_{n^2} + F$ where F is a 1-factor defined in the last section. First we introduce two similar lemmas as in the case when n is odd.

Before we show the next lemma, we first remark that when $n = 2k$, $A_{i,k} = A'_{i,k}$ and therefore $D_{\{i,k\}} = A_{i,k} \cup A_{k,i}$ and $C_k = A_{k,k}$.

Lemma 3.2. Lemma 3.1 is valid for $n = 2k$ if none of the subscripts is k .

Proof. The proof is the same as Lemma 3.1.

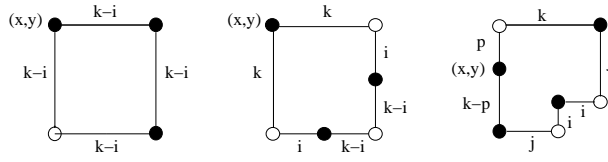

Figure 5: $R_{x,y}^1$ and $R_{x,y}^2$ for Lemma 3.3, and $R_{x,y}$ for Lemma 3.4.

Lemma 3.3. If $n = 2k$ and $1 \leq i \leq k - 1$, then $B_{k-i} \cup C_{k-i} \cup D_{\{i,k\}}$ can be partitioned into $2n^2$ 3-cycles. There exists a shortest path routing over $T(n)$ and the resulting load is uniform.

Proof. The proof is the same as before, so we will only list the basic cycles.

For $0 \leq x, y \leq n - 1$ (and for fixed $1 \leq i \leq k - 1$):

$$C_{x,y}^1 = ((x, y), (x + k - i, y), (x + k - i, y - k + i), (x, y))$$

$$C_{x,y}^2 = ((x, y), (x + k, y - i), (x + i, y - k), (x, y)).$$

The cycles $C_{x,y}^1$ and $C_{x,y}^2$ form a partition of $A_{k-i,k-i} \cup B_{k-i}$ and $D_{\{i,k\}} \cup A'_{k-i,k-i}$, respectively, for $1 \leq i \leq k - 1$.

See Figure 5 for the routings corresponding to the cycles $C_{x,y}$ and $C'_{x,y}$. \square

Now we prove Theorem D which is the even version of Theorem C.

Proof of Theorem D. Let $n = 2k$. We first partition the edges of K_{n^2} except the ones in $C_k \cup B_k$.

Case 1: $k \equiv 1, 2 \pmod{4}$. Consider the groups $B_{k-i} \cup C_{k-i} \cup D_{\{i,k\}}$, $1 \leq i \leq k - 1$. By Lemma 3.3, they can be partitioned into 3-cycles. We claim that the remaining $D_{\{i,j\}}$, $1 \leq i < j \leq k - 1$, can be paired and therefore, by using Lemma 3.1(1), we can partition them into 4-cycles.

Assume $k \equiv 1 \pmod{4}$. If i is even, then there are even number of j 's such that $i + 1 \leq j \leq k - 1$. If i is odd, then first we pair the $D_{\{i,k-1\}}$ (there are an even number of

odd i as $1 \leq i \leq k - 2$), and then for fixed odd i , there are an even number of j 's such that $i + 1 \leq j \leq k - 2$.

A similar argument can be applied to the case when $k \equiv 2 \pmod{4}$ by interchanging the odd and even i case.

Case 2: $k \equiv 0, 3 \pmod{4}$. We can not do exactly the same as in case 1 as we have an odd number of $D_{\{i,j\}}$ to be paired. We will need the following lemma.

Lemma 3.4. If $n = 2k$, $1 \leq i, j, p \leq k - 1$ and $i + j = k$, then $B_{k-p} \cup D_{\{p,k\}} \cup D_{\{i,j\}}$ can be partitioned into n^2 4-cycles with a shortest path routing of uniform load over $T(n)$.

Proof. We will only list the basic cycles as before. For $0 \leq x, y \leq n - 1$, define cycles

$$C_{x,y} = ((x, y), (x + k, y + p), (x + k - i, y + p - j), (x, y + p - k), (x, y))$$

and $C'_{x,y} = \alpha(C_{x,y})$. See Figure 5 for the routing of $C_{x,y}$. \square

To finish the proof for $k \geq 7$, consider the groups:

$$B_{k-i} \cup C_{k-i} \cup D_{\{i,k\}} \text{ for } 2 \leq i \leq k - 2$$

$$B_1 \cup D_{\{k-1,k\}} \cup D_{\{2,k-2\}} \text{ and } B_{k-1} \cup D_{\{1,k\}} \cup D_{\{3,k-3\}}$$

$$C_1 \cup C_{k-1} \cup D_{\{1,k-1\}}$$

They are decomposable by Lemmas 3.2, 3.3 and 3.4.

Now we only need to deal with $\bigcup_{1 \leq i < j \leq k-1} D_{\{i,j\}}$ except $D_{\{1,k-1\}}$, $D_{\{2,k-2\}}$ and $D_{\{3,k-3\}}$. This gives all together $(k-2)(k-1)/2 - 3$ sets, an even number of $D_{\{i,j\}}$ which can be easily paired by Lemma 3.2.

It remains to deal with $k = 3, 4$.

When $k = 3$, consider $B_1 \cup B_2 \cup D_{\{1,3\}} \cup D_{\{2,3\}}$ and $C_1 \cup C_2 \cup D_{\{1,2\}}$.

When $k = 4$, consider $C_2 \cup D_{\{1,3\}}$, $C_3 \cup D_{\{1,2\}}$, $B_1 \cup D_{\{2,4\}} \cup D_{\{3,4\}}$, $D_{1,4} \cup C_1 \cup A_{2,3} \cup A'_{3,2}$ and $B_2 \cup B_3 \cup A_{3,2} \cup A'_{2,3}$.

The only edge set we have not dealt with is $B_k \cup C_k \cup F$. By using Lemma 2.3, these edges can be partitioned into $n^2/2$ 4-cycles and the associated routing gives a uniform load

(or the difference between the maximum and the minimum loads is 1) if k is odd, and a quasi uniform load when k is even. Hence we have a $\{C_3, C_4\}$ -partition of $K_{n^2} + F$ with an associated optimal routing if k is odd, or a quasi optimal routing if k is even over $T(n)$.

4 Conclusion

We have considered the problem of designing a survivable WDM network for all-to-all communication in a network based on covering the initial network with subnetworks that are protected independently from each other. We give optimal, quasi optimal or asymptotically optimal solutions for the case when the network is a square torus and subnetworks are cycles. We would like to improve the asymptotic optimal solution, at least to obtain a solution which differs from the optimal one by some constant. It will also be interesting if we can extend similar results to other network structures.

5 Acknowledgments

The authors thank D. Coudert and F. Tillerot for stimulating discussions. The work of the first author was partially supported by the CRC CORSO with France Telecom and by the European Community project IST FET AEOLUS. The second author would like to thank the support of CNRS-INRIA-UNSA and the hospitality of the MASCOTTE project where the research was done during his visits.

References

- [1] B. Beauquier, All-to-all communication in some wavelength-routed all optical networks, *Networks* 33 (1999), 179-187.
- [2] B. Beauquier, Communications dans les réseaux optiques par multiplexage en longueur d'onde, PhD thesis, Université de Nice Sophia-Antipolis, January 2000.

- [3] J.-C. Bermond, L. Chacon, D. Coudert, and F. Tillerot, A note on cycle covering, *ACM Symposium on Parallel Algorithms and Architectures – SPAA*, Crete, July 2001, pp. 310-311.
- [4] J.-C. Bermond, D. Coudert, and M.-L. Yu, On DRC-covering of K_n by cycles, *Journal of Combinatorial Designs* 11 (2003), 100-112.
- [5] J.-C. Bermond, L. Gargano, S. Perennes, A. Rescigno, and U. Vaccaro, Efficient collective communications in optical networks, *Proc. 23rd ICALP96, Lecture Notes in Computer Science 1099*, Springer Verlag, Paderborn, Germany, 1996, pp. 574-585.
- [6] T. Eilam, S. Moran, and S. Zaks, Approximation algorithms for survivable optical networks, *The 14th International Symposium on Distributed Computing (DISC)*, 2000, pp. 104-118.
- [7] G. Ellinas, A. Hailemariam, and T. Stern, Protection cycles in mesh WDM networks, *IEEE Journal on Selected Areas in Communications* 18 (2000), 1924-1937.
- [8] O. Gerstel, P. Lin, and G. Sasaki, Wavelength assignment in a WDM ring to minimize system cost instead of number of wavelengths, *PROC IEEE INFOCOM*, 1998, pp. 94-101.
- [9] E. Limal, B. Mikkelsen, and K.E. Stubkjaer, Building WDM wide area resilient network from 4-node semi-mesh and mesh sub-networks, *IEEE International Conference on Communication (ICC)*, Montreal, Canada, June 1997, pp. 1311-1319.
- [10] H. Schroder, O. Sykora, and I. Vrt'o, Optical all-to-all communication for some product graphs, *Proc. (SOFSEM)'97: Theory and Practice of Informatics, Lecture Notes in Computer Science 1338*, Springer, Berlin, 1997, pp. 552-562.
- [11] F. Tillerot, E. Didelet, A. Daviaud, and G. Claveau, Efficient network upgrade based on a WDM optical layer with automatic protection switching, *OSA Optical Fiber Communications Conference (OFC)*, San Jose, CA, USA, 1998, pp. 296-297.