

Implicit Euler Numerical Simulation of Sliding Mode Systems

Vincent Acary and Bernard Brogliato,
INRIA Grenoble Rhône-Alpes

Conference in honour of E. Hairer's 60th birthday

Genève, 17-20 June 2009

Objectives

- ▶ Study the implicit Euler discretization of a class of differential inclusions with sliding surfaces (\subset Filippov's systems)
- ▶ Show that this numerical method permits a smooth stabilization on the sliding surface, in a finite number of steps
- ▶ Show how this may be used in real-time implementations of sliding mode control

To start with we consider the simplest case:

$$\dot{x}(t) \in -\text{sgn}(x(t)) = \begin{cases} 1 & \text{if } x(t) < 0 \\ -1 & \text{if } x(t) > 0 \\ [-1,1] & \text{if } x(t) = 0 \end{cases}, \quad x(0) = x_0 \quad (1)$$

with $x(t) \in \mathbf{R}$. This system possesses a unique Lipschitz continuous solution for any x_0 . The backward Euler discretization of (1) reads as:

$$\begin{cases} x_{k+1} - x_k = -hs_{k+1} \\ s_{k+1} \in \text{sgn}(x_{k+1}) \end{cases} \quad (2)$$

As is known the *explicit* Euler discretization of such discontinuous systems yields spurious oscillations around the switching surface [Galias et al, IEEE TAC and CAS 2006, 2007, 2008].

↪ this means that the derivative of the switching function while sliding occurs, is very badly estimated.

Both the explicit and the implicit methods converge (the approximated solution $x^N(\cdot)$ tends to the Filippov's solution as $h \rightarrow 0$).

However for the backward Euler method the following holds:

Lemma

For all $h > 0$ and $x_0 \in \mathbf{R}$, there exists k_0 such that $x_{k_0+n} = 0$ and $\frac{x_{k_0+n+1} - x_{k_0+n}}{h} = 0$ for all $n \geq 1$.

On this simple case this has the following graphical interpretation, as the intersection of two graphs:

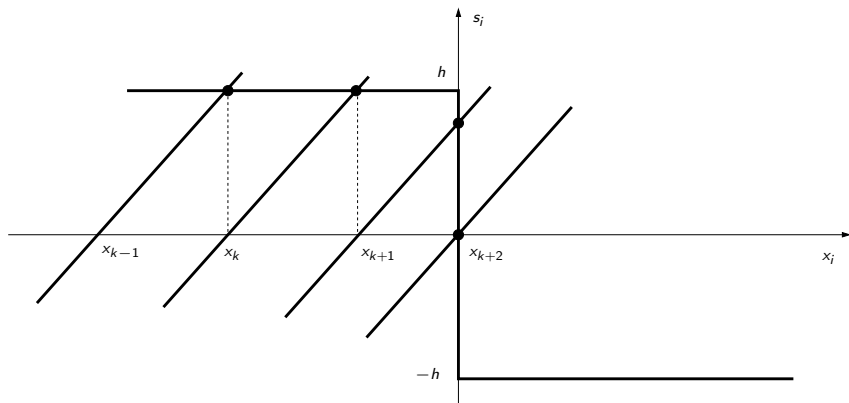

Figure: Iterations of the backward Euler method.

An interesting property is that the smooth stabilization and the finite-time convergence on the switching surface, hold (more or less) independently of the step $h > 0$:

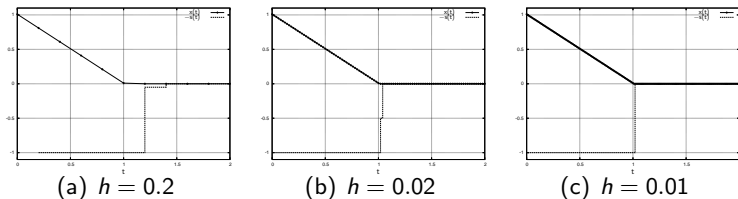

Figure: A simple example for $x_0 = 1.01$ at $t_0 = 0$.

EXTENSIONS

We shall focus on inclusions of the form:

$$\begin{cases} \dot{x}(t) \in f(t, x(t)) - B \operatorname{Sgn}(Cx(t) + D), \text{ a.e. on } (0, T) \\ x(0) = x_0 \end{cases} \quad (3)$$

with

$$B \in \mathbf{R}^{n \times m}$$

$\operatorname{Sgn}(Cx(t) + D) \triangleq (\operatorname{sgn}(C_1x + D_1), \dots, \operatorname{sgn}(C_mx + D_m))^T \in \mathbf{R}^m$,
where $\operatorname{sgn}(\cdot)$ is multivalued at 0.

Well-posedness of the differential inclusions (3)

Proposition

Consider the differential inclusion in (3). Suppose that

- ▶ There exists $L \geq 0$ such that for all $t \in [0, T]$, for all $x_1, x_2 \in \mathbf{R}^n$, one has $\|f(t, x_1) - f(t, x_2)\| \leq L\|x_1 - x_2\|$.
- ▶ There exists a function $\Phi(\cdot)$ such that for all $R \geq 0$:

$$\Phi(R) = \sup \left\{ \left\| \frac{\partial f}{\partial t}(\cdot, v) \right\|_{\mathcal{L}^2((0, T); \mathbf{R}^n)} \mid \|v\|_{\mathcal{L}^2((0, T); \mathbf{R}^n)} \leq R \right\} < +\infty.$$

If there exists an $n \times n$ matrix $P = P^T > 0$ such that

$$PB_{\bullet i} = C_i^T \tag{4}$$

for all $1 \leq i \leq m$, then for any initial data the differential inclusion (3) has a unique solution $x : (0, T) \rightarrow \mathbf{R}^n$ that is Lipschitz continuous.

Proof of Proposition 1: The proof uses the change of state variables $z = Rx$ where $R = R^T > 0$ and $R^2 = P$. After some manipulations the system is rewritten as

$$\dot{z}(t) \in Rf(t, R^{-1}z(t)) - \sum_{i=1}^m \partial f_i(z(t)) \quad (5)$$

where $f_i(z) = |C_i \bullet R^{-1}z + D_i|$. The multivalued mapping $z \mapsto \sum_{i=1}^m \partial f_i(z(t))$ is maximal monotone. We then use a result in [Bastien-Schatzman ESAIM M2AN 2002] to conclude.

- ▶ The existence of a positive definite P such that $PB = C^T$ is satisfied in many instances of sliding-mode control: observer-based sliding-mode control, Lyapunov-based discontinuous robust control.
- ▶ This is an “input-output” constraint on the system, constraining the relative degree of the triple (A, B, C) .
- ▶ It is satisfied when (A, B, C) is positive real (dissipative).

Time-discretization of (3)

The differential inclusion in (3) is therefore discretized as follows:

$$\begin{cases} \frac{x_{k+1} - x_k}{h} \in f(t_k, x_k) - BSgn(Cx_{k+1} + D), \text{ a.e. on } (0, T) \\ x(0) = x_0 \end{cases} \quad (6)$$

From [Bastien-Schatzman ESAIM M2AN 2002] we have that:

Proposition

Under Proposition 1 conditions, there exists η such that for all $h > 0$ one has

$$\text{For all } t \in [0, T], \|x(t) - x^N(t)\| \leq \eta \sqrt{h} \quad (7)$$

Moreover

$$\lim_{h \rightarrow 0^+} \max_{t \in [0, T]} \|x(t) - x^N(t)\|^2 + \int_0^t \|x(s) - x^N(s)\|^2 ds = 0.$$

However we have more: the discrete state reaches the sliding surface (when it exists) in a finite number of steps, and stabilizes on it in a smooth way.

Let $y(t) \triangleq Cx(t) + D$.

Lemma

Let us assume that a sliding mode occurs for the index $\alpha \in \{1 \dots m\}$, that is $y_\alpha(t) = 0, t > t_$. Let C and B be such that (4) holds and $C_{\alpha\bullet}B_{\bullet\alpha} > 0$. Then there exists $h_c > 0$ such that $\forall h < h_c$, there exists $k_0 \in \mathbf{N}$ such that $y_{k_0+n} = Cx_{k_0+n+1} + D = 0$ for all integers $n \geq 1$.*

Such algorithms are similar to proximal algorithms which possess finite-time stabilization properties [Baji and Cabot, Set-Valued Analysis 2006].

Remarks

- ▶ Contrarily to other methods that reduce (not suppress...) chattering, the discrete-time sliding surface is equal to the continuous-time sliding surface.
- ▶ At each step one has to solve a generalized equation with unknown x_{k+1} that takes the form of a mixed linear complementarity system (MLCP).
- ▶ Specific MLCP solvers are needed to implement the method.

NUMERICAL EXPERIMENTS

Let us consider the following two examples:

$$\dot{x} = \begin{bmatrix} 0 & 1 \\ 0 & -c_1 \end{bmatrix} x - \begin{bmatrix} 0 \\ \alpha \end{bmatrix} \operatorname{sgn}([c_1 \ 1] x). \quad (8)$$

(codimension one sliding surface)

$$B = \begin{bmatrix} 1 & 2 \\ 2 & -1 \end{bmatrix}, \quad C = \begin{bmatrix} 1 & 2 \\ 2 & -1 \end{bmatrix}, \quad D = 0, \quad f(x(t), t) = 0 \quad (9)$$

(codimension two sliding surface)

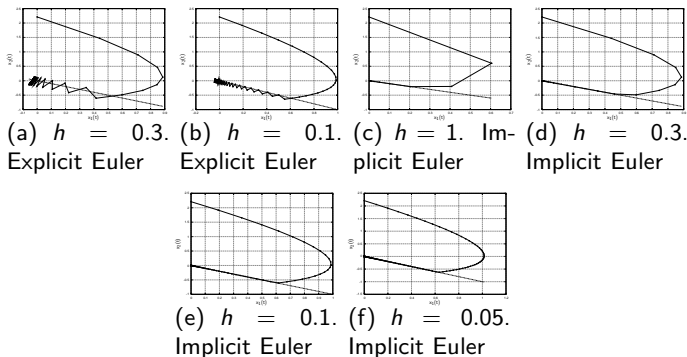
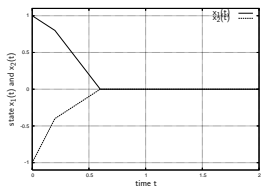
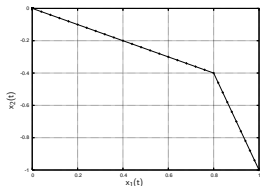

Figure: Equivalent control based SMC, $c_1 = 1, \alpha = 1$ and $x_0 = [0, 2.21]^T$. State $x_1(t)$ versus $x_2(t)$.



(a) state $x_1(t)$ and $x_2(t)$ versus time



(b) phase portrait $x_2(t)$ versus $x_1(t)$

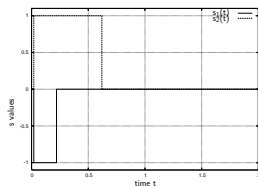

(c) sign function $s_1(t)$ and $s_2(t)$

Figure: Multiple Sliding surface. $h = 0.02$, $x(0) = [1.0, -1.0]^T$

The system reaches firstly the sliding surface $2x_2 + x_1 = 0$ without any chattering, The system then slides on the surface up to reaching the second sliding surface $2x_1 - x_2 = 0$ and comes to rest at the origin.

The Filippov's example with switches accumulation

$$B = \begin{bmatrix} 1 & -2 \\ 2 & 1 \end{bmatrix}, \quad C = \begin{bmatrix} 1 & 0 \\ 0 & 1 \end{bmatrix}, \quad D = 0, \quad f(x(t), t) = 0. \quad (10)$$

The trajectories may slide on the codimension 2 surface given by $Cx = 0$. The origin is attained after an infinite number of switches in finite time.

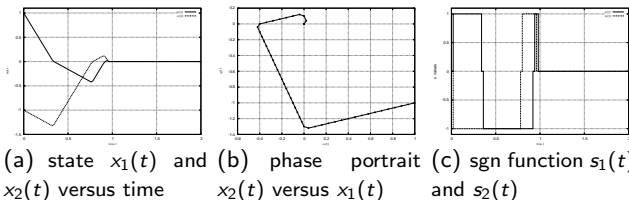

Figure: Multiple Sliding surface. Filippov Example. $h = 0.002$, $x(0) = [1.0, -1.0]^T$

The results show that the system reaches the origin without any chattering.

The case of Zero Holding discretization (ZOH) for control implementation

The ZOH discretization of linear time invariant systems $\dot{x}(t) = Fx(t) + Gu(t)$ with an ECB-SMC controller, $u(x) = -(CG)^{-1}(CFx + \alpha \text{Sgn}(Cx))$, $\alpha > 0$ results in a discrete-time system of the form:

$$x_{k+1} = \Phi x_k - \Gamma s_k \quad \text{for all } t \in [kh, (k+1)h) \quad (11)$$

where $h > 0$ is the sampling period, and

$$\Phi = \exp(Fh) - \int_0^h \exp(F\tau) d\tau G (CG)^{-1} CF \quad (12)$$

$$\Gamma = \int_0^h \exp(F\tau) G (CG)^{-1} d\tau \quad (13)$$

with $G \in \mathbf{R}^{n \times m}$, $C \in \mathbf{R}^{m \times n}$, when an explicit Euler implementation of the control is performed.

Similarly to the explicit Euler method, the explicit ZOH discretization may yield spurious oscillations as shown in [Galias-Yu, IEEE CAS 2008].

For an implicit Euler implementation, let us set

$$\begin{cases} u_k = -(CG)^{-1}(CFx_k + s_{k+1}) \\ s_{k+1} = \text{Sgn}(Cx_{k+1}), \end{cases} \quad (14)$$

which corresponds to the implicit discrete time version of the ECB-SMC controller. We therefore get on each sampling period:

$$x_{k+1} = \Phi x_k - \Gamma s_{k+1} \quad \text{for all } t \in [kh, (k+1)h) \quad (15)$$

At each time-step, one has to solve

$$\begin{cases} x_{k+1} = \Phi x_k - \Gamma s_{k+1} \\ y_{k+1} = C x_{k+1} + D \\ s_{k+1} \in \text{Sgn}(y_{k+1}) \end{cases} . \quad (16)$$

Inserting the first line of (16) into the second line we obtain the following one-step system (MLCP)

$$\begin{cases} y_{k+1} = C \Phi x_k + D - C \Gamma s_{k+1} \\ s_{k+1} \in \text{Sgn}(y_{k+1}) \end{cases} . \quad (17)$$

The control scheme looks like:

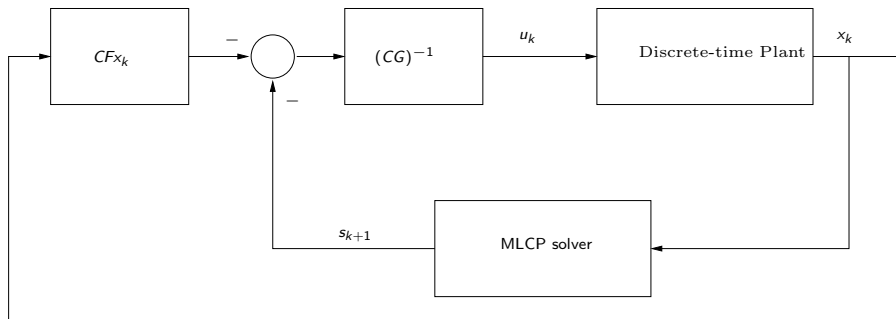

Figure: Control system scheme with implicit Euler implementation.

A numerical example

The LTI system with an ECB-SMC controller is defined by the following data,

$$F = \begin{bmatrix} 0 & 1 \\ -a_1 & -a_2 \end{bmatrix}, \quad G = \begin{bmatrix} 0 \\ 1 \end{bmatrix}, \quad C = [c_1 \quad 1]. \quad (18)$$

Starting from the initial data, $x_0 = [0.55, 0, 55]^T$, [Galias-Yu, IEEE CAS 2008] have shown that the Explicit ZOH discretization of the system with $a_1 = -2$, $a_2 = 2$, $c_1 = 1$ and $h = 0.3$ exhibits a period-2 orbit.

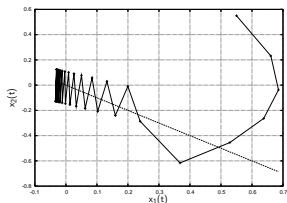

(a) $h = 0.3$. Explicit ZOH

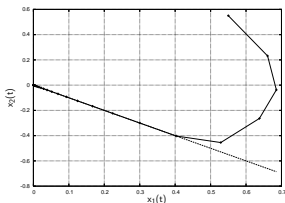

(b) $h = 0.3$. Implicit ZOH

Figure: Equivalent control based SMC, $a_1 = -2$, $a_2 = 2$, $c_1 = 1$ and $h = 0.3$. $x_0 = [0.55, 0, 55]^T$ State $x_1(t)$ versus $x_2(t)$.

\rightsquigarrow *the chattering on the switching surface is suppressed.*

CONCLUSIONS

The implicit Euler method allows one to nicely simulate the main features of sliding-mode systems:

- ▶ Finite-time stabilization on the switching surface (of codimension ≥ 1)
- ▶ Smooth stabilization on the switching surface

It extends to the discrete-time implementation with ZOH discretization: looks like a promising solution for discrete-time sliding modes.