



HAL
open science

Non Smooth Dynamical Systems: Analysis, control, simulation and applications

Vincent Acary

► **To cite this version:**

Vincent Acary. Non Smooth Dynamical Systems: Analysis, control, simulation and applications. Doctoral. France. 2006, pp.1-159. inria-00423540

HAL Id: inria-00423540

<https://inria.hal.science/inria-00423540>

Submitted on 24 Oct 2018

HAL is a multi-disciplinary open access archive for the deposit and dissemination of scientific research documents, whether they are published or not. The documents may come from teaching and research institutions in France or abroad, or from public or private research centers.

L'archive ouverte pluridisciplinaire **HAL**, est destinée au dépôt et à la diffusion de documents scientifiques de niveau recherche, publiés ou non, émanant des établissements d'enseignement et de recherche français ou étrangers, des laboratoires publics ou privés.

Lecture 1. Formulations of
Non Smooth Dynamical
Systems (NSDS).

Vincent Acary

Outline

Lagrangian dynamical
systems with unilateral
constraints

The Moreau's sweeping
process of first order

Dynamical Complementarity
Systems (DCS)

Other NSDS: A very short
zoology

Higher order relative degree
systems

References

Lecture 1. Formulations of Non Smooth Dynamical Systems (NSDS).

Vincent Acary

June 7, 2006

1 Outline

2 Lagrangian dynamical systems with unilateral constraints

- The smooth multibody dynamics
- The Non smooth Lagrangian Dynamics
- The Moreau's sweeping process

3 The Moreau's sweeping process of first order

4 Dynamical Complementarity Systems (DCS)

- Definitions
- The notion of relative degree. Well-posedness
- The LCS of relative degree $r \leq 1$. The passive LCS

5 Other Non Smooth Dynamical systems: A very short zoology

- Differential inclusions (DI)
- Evolution Variational inequalities (EVI)
- Differential Variational Inequalities (DVI)
- Projected Dynamical Systems (PDS)
- Piece-Wise affine (PWA) and piece-wise continuous (PWC) systems
- And other systems

6 Higher order relative degree systems

Definition (Lagrange's equations)

$$\frac{d}{dt} \left(\frac{\partial L(q, v)}{\partial v_i} \right) - \frac{\partial L(q, v)}{\partial q_i} = Q_i(q, t), \quad i \in \{1 \dots n\}, \quad (1)$$

where

- $q(t) \in \mathbb{R}^n$ generalized coordinates,
- $v(t) = \frac{dq(t)}{dt} \in \mathbb{R}^n$ generalized velocities,
- $Q(q, t) \in \mathbb{R}^n$ generalized forces
- $L(q, v) \in \mathbb{R}$ Lagrangian of the system,

$$L(q, v) = T(q, v) - V(q),$$

together with

- $T(q, v) = \frac{1}{2} v^T M(q) v$, kinetic energy, $M(q) \in \mathbb{R}^{n \times n}$ mass matrix,
- $V(q)$ potential energy of the system,

The smooth multibody dynamics

Lecture 1. Formulations of Non Smooth Dynamical Systems (NSDS).

Vincent Acary

Outline

Lagrangian dynamical systems with unilateral constraints

The smooth multibody dynamics

The Non smooth Lagrangian Dynamics

The Moreau's sweeping process

The Moreau's sweeping process of first order

Dynamical Complementarity Systems (DCS)

Other NSDS: A very short zoology

Higher order relative degree systems

References

Lagrange equations

$$M(q) \frac{dv}{dt} + N(q, v) = Q(q, t) - \nabla_q V(q) \quad (2)$$

where

$$\blacksquare N(q, v) = \left[\frac{1}{2} \sum_{k,l} \frac{\partial M_{ik}}{\partial q_l} + \frac{\partial M_{il}}{\partial q_k} - \frac{\partial M_{kl}}{\partial q_i}, i = 1 \dots n \right] \text{ the nonlinear inertial terms i.e., the gyroscopic accelerations}$$

Internal and external forces which do not derive from a potential

$$M(q) \frac{dv}{dt} + N(q, v) + F_{int}(t, q, v) = F_{ext}(t), \quad (3)$$

where

- $\blacksquare F_{int} : \mathbb{R}^n \times \mathbb{R}^n \times \mathbb{R} \rightarrow \mathbb{R}^n$ non linear interactions between bodies,
- $\blacksquare F_{ext} : \mathbb{R} \rightarrow \mathbb{R}^n$ external applied loads.

Linear time invariant (LTI) case

- $\blacksquare M(q) = M \in \mathbb{R}^{n \times n}$ mass matrix
- $\blacksquare F_{int}(t, q, v) = Cv + Kq, C \in \mathbb{R}^{n \times n}$ is the viscosity matrix, $K \in \mathbb{R}^{n \times n}$

Definition (Smooth multibody dynamics)

$$\begin{cases} M(q) \frac{dv}{dt} + F(t, q, v) = 0, \\ v = \dot{q} \end{cases} \quad (4)$$

where

- $F(t, q, v) = N(q, v) + F_{int}(t, q, v) - F_{ext}(t)$

Definition (Boundary conditions)

- Initial Value Problem (IVP):

$$t_0 \in \mathbb{R}, \quad q(t_0) = q_0 \in \mathbb{R}^n, \quad v(t_0) = v_0 \in \mathbb{R}^n, \quad (5)$$

- Boundary Value Problem (BVP):

$$(t_0, T) \in \mathbb{R} \times \mathbb{R}, \quad \Gamma(q(t_0), v(t_0), q(T), v(T)) = 0 \quad (6)$$

Perfect bilateral constraints, joints, liaisons and spatial boundary conditions

Lecture 1. Formulations of Non Smooth Dynamical Systems (NSDS).

Vincent Acary

Outline

Lagrangian dynamical systems with unilateral constraints

The smooth multibody dynamics

The Non smooth Lagrangian Dynamics

The Moreau's sweeping process

The Moreau's sweeping process of first order

Dynamical Complementarity Systems (DCS)

Other NSDS: A very short zoology

Higher order relative degree systems

References

Bilateral constraints

- Finite set of m bilateral constraints on the generalized coordinates :

$$h(q, t) = [h_j(q, t) = 0, \quad j \in \{1 \dots m\}]^T. \quad (7)$$

where h_j are sufficiently smooth with regular gradients, $\nabla_q(h_j)$.

- Configuration manifold, $\mathcal{M}(t)$

$$\mathcal{M}(t) = \{q(t) \in \mathbb{R}^n, h(q, t) = 0\}, \quad (8)$$

Tangent and normal space

- Tangent space to the manifold \mathcal{M} at q

$$T_{\mathcal{M}}(q) = \{\xi, \nabla h(q)^T \xi = 0\} \quad (9)$$

- Normal space as the orthogonal to the tangent space

$$N_{\mathcal{M}}(q) = \{\eta, \eta^T \xi = 0, \forall \xi \in T_{\mathcal{M}}\} \quad (10)$$

Definition (Perfect bilateral holonomic constraints on the smooth dynamics)

Introduction of the multipliers $\mu \in \mathbb{R}^m$

$$\begin{cases} M(q) \frac{dv}{dt} + F(t, q, v) = r = \nabla_q^T h(q, t) \mu \\ -r \in N_{\mathcal{M}}(q) \end{cases} \quad (11)$$

where $r = \nabla_q^T h(q, t) \mu$ generalized forces or generalized reactions due to the constraints.

Remark

- The formulation as an inclusion is very useful in practice
- The constraints are said to be perfect due to the normality condition.

Unilateral constraints

- Finite set of ν unilateral constraints on the generalized coordinates :

$$g(q, t) = [g_\alpha(q, t) \geq 0, \quad \alpha \in \{1 \dots \nu\}]^T. \quad (12)$$

- Admissible set $\mathcal{C}(t)$

$$\mathcal{C}(t) = \{q \in \mathcal{M}(t), g_\alpha(q, t) \geq 0, \alpha \in \{1 \dots \nu\}\}. \quad (13)$$

Normal cone to $\mathcal{C}(t)$

$$N_{\mathcal{C}(t)}(q(t)) = \left\{ y \in \mathbb{R}^n, y = - \sum_{\alpha} \lambda_{\alpha} \nabla g_{\alpha}(q, t), \lambda_{\alpha} \geq 0, \lambda_{\alpha} g_{\alpha}(q, t) = 0 \right\} \quad (14)$$

Unilateral constraints as an inclusion

Lecture 1. Formulations of Non Smooth Dynamical Systems (NSDS).

Vincent Acary

Outline

Lagrangian dynamical systems with unilateral constraints

The smooth multibody dynamics

The Non smooth Lagrangian Dynamics

The Moreau's sweeping process

The Moreau's sweeping process of first order

Dynamical Complementarity Systems (DCS)

Other NSDS: A very short zoology

Higher order relative degree systems

References

Definition (Perfect unilateral constraints on the smooth dynamics)

Introduction of the multipliers $\mu \in \mathbb{R}^m$

$$\begin{cases} M(q) \frac{dv}{dt} + F(t, q, v) = r = \nabla_q^T h(q, t) \lambda \\ -r \in N_{C(t)}(q(t)) \end{cases} \quad (15)$$

where $r = \nabla_q^T g(q, t) \lambda$ generalized forces or generalized reactions due to the constraints.

Remark

- The unilateral constraints are said to be perfect due to the normality condition.
- Notion of normal cones can be extended to more general sets. see (CLARKE, 1975, 1983 ; MORDUKHOVICH, 1994)
- The right hand side is neither bounded (and then nor compact).
- The inclusion and the constraints concern the second order time derivative of q .

→ Standard Analysis of DI does no longer apply.

Fundamental assumptions.

- The velocity $v = \dot{q}$ is of Bounded Variations (B.V)
→ The equation are written in terms of a right continuous B.V. (R.C.B.V.) function, v^+ such that

$$v^+ = \dot{q}^+ \quad (16)$$

- q is related to this velocity by

$$q(t) = q(t_0) + \int_{t_0}^t v^+(t) dt \quad (17)$$

- The acceleration, (\ddot{q} in the usual sense) is hence a differential measure dv associated with v such that

$$dv([a, b]) = \int_{]a, b[} dv = v^+(b) - v^+(a) \quad (18)$$

Definition (Non Smooth Lagrangian Dynamics)

$$\begin{cases} M(q)dv + F(t, q, v^+)dt = dr \\ v^+ = \dot{q}^+ \end{cases} \quad (19)$$

where dr is the reaction measure and dt is the Lebesgue measure.

Remarks

- The non smooth Dynamics contains the impact equations and the smooth evolution in a single equation.
- The formulation allows one to take into account very complex behaviors, especially, finite accumulation (Zeno-state).
- This formulation is sound from a mathematical Analysis point of view.

References

(SCHATZMAN, 1973, 1978 ; MOREAU, 1983, 1988)

Decomposition of measure

$$\begin{cases} dv = \gamma dt + (v^+ - v^-) d\nu + dv_S \\ dr = f dt + p d\nu + dr_S \end{cases} \quad (20)$$

where

- $\gamma = \ddot{q}$ is the acceleration defined in the usual sense.
- f is the Lebesgue measurable force,
- $v^+ - v^-$ is the difference between the right continuous and the left continuous functions associated with the B.V. function $v = \dot{q}$,
- $d\nu$ is a purely atomic measure concentrated at the time t_i of discontinuities of v , i.e. where $(v^+ - v^-) \neq 0$, i.e. $d\nu = \sum_i \delta_{t_i}$
- p is the purely atomic impact percussions such that $p d\nu = \sum_i p_i \delta_{t_i}$
- dv_S and dr_S are singular measures with the respect to $dt + d\eta$.

Substituting the decomposition of measures into the non smooth Lagrangian Dynamics, one obtains

Definition (Impact equations)

$$M(q)(v^+ - v^-)d\nu = pd\nu, \quad (21)$$

or

$$M(q(t_i))(v^+(t_i) - v^-(t_i)) = p_i, \quad (22)$$

Definition (Smooth Dynamics between impacts)

$$M(q)\gamma dt + F(t, q, v)dt = fdt \quad (23)$$

or

$$M(q)\gamma^+ + F(t, q, v^+) = f^+ \quad [dt - a.e.] \quad (24)$$

The Moreau's sweeping process of second order

Lecture 1. Formulations of Non Smooth Dynamical Systems (NSDS).

Vincent Acary

Outline

Lagrangian dynamical systems with unilateral constraints

The smooth multibody dynamics

The Non smooth Lagrangian Dynamics

The Moreau's sweeping process

The Moreau's sweeping process of first order

Dynamical Complementarity Systems (DCS)

Other NSDS: A very short zoology

Higher order relative degree systems

References

Definition (MOREAU (1983, 1988))

A key stone of this formulation is the inclusion in terms of velocity. Indeed, the inclusion (15) is “replaced” by the following inclusion

$$\begin{cases} M(q)dv + F(t, q, v^+)dt = dr \\ v^+ = \dot{q}^+ \\ -dr \in N_{T_C(q)}(v^+) \end{cases} \quad (25)$$

Comments

This formulation provides a common framework for the non smooth dynamics containing inelastic impacts without decomposition.
→ Foundation for the time-stepping approaches.

The Moreau's sweeping process of second order

Lecture 1. Formulations of Non Smooth Dynamical Systems (NSDS).

Vincent Acary

Outline

Lagrangian dynamical systems with unilateral constraints

The smooth multibody dynamics

The Non smooth Lagrangian Dynamics

The Moreau's sweeping process

The Moreau's sweeping process of first order

Dynamical Complementarity Systems (DCS)

Other NSDS: A very short zoology

Higher order relative degree systems

References

Comments

- *The inclusion concerns measures.* Therefore, it is necessary to define what is the inclusion of a measure into a cone.
- *The inclusion in terms of velocity v^+* rather than of the coordinates q .

Interpretation

- Inclusion of measure, $-dr \in K$

- Case $dr = r' dt = f dt.$

$$-f \in K \quad (26)$$

- Case $dr = p_i \delta_i.$

$$-p_i \in K \quad (27)$$

- Inclusion in terms of the velocity. Viability Lemma
If $q(t_0) \in C(t_0)$, then

$$v^+ \in T_C(q), t \geq t_0 \Rightarrow q(t) \in C(t), t \geq t_0$$

→ The unilateral constraints on q are satisfied. The equivalence needs at least an impact inelastic rule.

The Moreau's sweeping process of second order

Lecture 1. Formulations of Non Smooth Dynamical Systems (NSDS).

Vincent Acary

Outline

Lagrangian dynamical systems with unilateral constraints

The smooth multibody dynamics

The Non smooth Lagrangian Dynamics

The Moreau's sweeping process

The Moreau's sweeping process of first order

Dynamical Complementarity Systems (DCS)

Other NSDS: A very short zoology

Higher order relative degree systems

References

The Newton-Moreau impact rule

$$-dr \in N_{T_C(q(t))}(v^+(t) + ev^-(t)) \quad (28)$$

where e is a coefficient of restitution.

The Moreau's sweeping process of second order

Lecture 1. Formulations of Non Smooth Dynamical Systems (NSDS).

Vincent Acary

Outline

Lagrangian dynamical systems with unilateral constraints

The smooth multibody dynamics

The Non smooth Lagrangian Dynamics

The Moreau's sweeping process

The Moreau's sweeping process of first order

Dynamical Complementarity Systems (DCS)

Other NSDS: A very short zoology

Higher order relative degree systems

References

The case of C is finitely represented

$$C = \{q \in \mathcal{M}(t), g_\alpha(q) \geq 0, \alpha \in \{1 \dots \nu\}\}. \quad (29)$$

Decomposition of dr and v^+ onto the tangent and the normal cone.

$$dr = \sum_{\alpha} \nabla_q^T g_\alpha(q) d\lambda_\alpha \quad (30)$$

$$U_\alpha^+ = \nabla_q g_\alpha(q) v^+, \alpha \in \{1 \dots \nu\} \quad (31)$$

Complementarity formulation (under constraints qualification condition)

$$-d\lambda_\alpha \in N_{T_{\mathbb{R}_+}(g_\alpha)}(U_\alpha^+) \Leftrightarrow \text{if } g_\alpha(q) \leq 0, \text{ then } 0 \leq U_\alpha^+ \perp d\lambda_\alpha \geq 0 \quad (32)$$

The case of C is \mathbb{R}_+

$$-dr \in N_C(q) \Leftrightarrow 0 \leq q \perp dr \geq 0 \quad (33)$$

is replaced by

$$-dr \in N_{T_C(q)}(v^+) \Leftrightarrow \text{if } q \leq 0, \text{ then } 0 \leq v^+ \perp dr \geq 0 \quad (34)$$

The Moreau's sweeping process of second order

Lecture 1. Formulations of Non Smooth Dynamical Systems (NSDS).

Vincent Acary

Outline

Lagrangian dynamical systems with unilateral constraints

The smooth multibody dynamics

The Non smooth Lagrangian Dynamics

The Moreau's sweeping process

The Moreau's sweeping process of first order

Dynamical Complementarity Systems (DCS)

Other NSDS: A very short zoology

Higher order relative degree systems

References

Example (The Bouncing Ball)

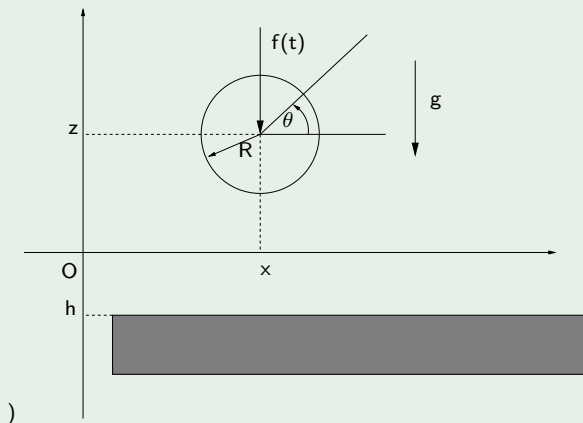

Figure: Two-dimensional bouncing ball on a rigid plane

The Moreau's sweeping process of second order

Lecture 1. Formulations of Non Smooth Dynamical Systems (NSDS).

Vincent Acary

Outline

Lagrangian dynamical systems with unilateral constraints

The smooth multibody dynamics

The Non smooth Lagrangian Dynamics

The Moreau's sweeping process

The Moreau's sweeping process of first order

Dynamical Complementarity Systems (DCS)

Other NSDS: A very short zoology

Higher order relative degree systems

References

Example (The Bouncing Ball)

In our special case, the model is completely linear:

$$q = \begin{bmatrix} z \\ x \\ \theta \end{bmatrix} \quad (35)$$

$$M(q) = \begin{bmatrix} m & 0 & 0 \\ 0 & m & 0 \\ 0 & 0 & I \end{bmatrix} \quad \text{where } I = \frac{3}{5}mR^2 \quad (36)$$

$$N(q, \dot{q}) = \begin{bmatrix} 0 \\ 0 \\ 0 \end{bmatrix} \quad (37)$$

$$F_{int}(q, \dot{q}, t) = \begin{bmatrix} 0 \\ 0 \\ 0 \end{bmatrix} \quad (38)$$

$$F_{ext}(t) = \begin{bmatrix} -mg \\ 0 \\ 0 \end{bmatrix} + \begin{bmatrix} f(t) \\ 0 \\ 0 \end{bmatrix} \quad (39)$$

The Moreau's sweeping process of second order

Lecture 1. Formulations of Non Smooth Dynamical Systems (NSDS).

Vincent Acary

Outline

Lagrangian dynamical systems with unilateral constraints

The smooth multibody dynamics

The Non smooth Lagrangian Dynamics

The Moreau's sweeping process

The Moreau's sweeping process of first order

Dynamical Complementarity Systems (DCS)

Other NSDS: A very short zoology

Higher order relative degree systems

References

Example (The Bouncing Ball)

Kinematics Relations The unilateral constraint requires that :

$$C = \{q, g(q) = z - R - h \geq 0\} \quad (35)$$

so we identify the terms of the equation the equation (30)

$$-dr = [1, 0, 0]^T d\lambda_1, \quad (36)$$

$$U_1^+ = [1, 0, 0] \begin{bmatrix} \dot{z} \\ \dot{x} \\ \dot{\theta} \end{bmatrix} = \dot{z} \quad (37)$$

Nonsmooth laws The following contact laws can be written,

$$\begin{cases} \text{if } g(q) \leq 0, \text{ then } 0 \leq U^+ + eU^- \perp d\lambda_1 \geq 0 \\ \text{if } g(q) \geq 0, d\lambda_1 = 0 \end{cases} \quad (38)$$

1 Outline

2 Lagrangian dynamical systems with unilateral constraints

- The smooth multibody dynamics
- The Non smooth Lagrangian Dynamics
- The Moreau's sweeping process

3 The Moreau's sweeping process of first order

4 Dynamical Complementarity Systems (DCS)

- Definitions
- The notion of relative degree. Well-posedness
- The LCS of relative degree $r \leq 1$. The passive LCS

5 Other Non Smooth Dynamical systems: A very short zoology

- Differential inclusions (DI)
- Evolution Variational inequalities (EVI)
- Differential Variational Inequalities (DVI)
- Projected Dynamical Systems (PDS)
- Piece-Wise affine (PWA) and piece-wise continuous (PWC) systems
- And other systems

6 Higher order relative degree systems

The Moreau's sweeping process of first order

Lecture 1. Formulations of
Non Smooth Dynamical
Systems (NSDS).

Vincent Acary

Outline

Lagrangian dynamical
systems with unilateral
constraints

The Moreau's sweeping
process of first order

Dynamical Complementarity
Systems (DCS)

Other NSDS: A very short
zoology

Higher order relative degree
systems

References

Definition (The Moreau's sweeping process (of first order))

The Moreau's sweeping process (of first order) is defined by the following Differential inclusion (DI)

$$\begin{cases} -\dot{x}(t) \in N_{K(t)}(x(t)) & t \in [0, T], \\ x(0) = x_0 \in K(0). \end{cases} \quad (39)$$

where

- $K(t)$ is a moving closed and nonempty convex set.
- $N_K(x)$ is the normal cone to K at x

$$N_K(x) := \{s \in \mathbb{R}^n : \langle s, y - x \rangle \leq 0, \text{ for all } y \in K\},$$

Comment

This terminology is explained by the fact that $x(t)$ can be viewed as a point which is swept by a moving convex set.

References

(MOREAU, 1971, 1972, 1977 ; MONTEIRO MARQUES, 1993 ; KUNZE & MONTEIRO MARQUES, 2000)

The Moreau's sweeping process of first order

Lecture 1. Formulations of
Non Smooth Dynamical
Systems (NSDS).

Vincent Acary

Outline

Lagrangian dynamical
systems with unilateral
constraints

The Moreau's sweeping
process of first order

Dynamical Complementarity
Systems (DCS)

Other NSDS: A very short
zoology

Higher order relative degree
systems

References

Basic mathematical properties (MONTEIRO MARQUES, 1993).

- A solution $x(\cdot)$ for such type of DI is assumed to be differentiable almost everywhere satisfying the inclusion $\dot{x}(t) \in K(t)$, $t \in [0, T]$.
- If the set-valued application $t \mapsto K(t)$ is supposed to be Lipschitz continuous, i.e.

$$\exists l \leq 0, \quad d_H(K(t), K(s)) \leq l|t - s| \quad (40)$$

where d_H is the Hausdorff distance between two closed sets, then

- existence of a solution which is l -Lipschitz continuous
- uniqueness in the class of absolutely continuous functions.

(MONTEIRO MARQUES, 1993).

Definition (State dependent sweeping process (KUNZE & MONTEIRO MARQUES, 1998))

The state dependent sweeping process is defined

$$\begin{cases} -\dot{x}(t) \in N_{K(t,x(t))}(x(t)) & t \in [0, T], \\ x(0) = x_0 \in K(0). \end{cases} \quad (41)$$

Variants of the Moreau's sweeping process

Lecture 1. Formulations of
Non Smooth Dynamical
Systems (NSDS).

Vincent Acary

Outline

Lagrangian dynamical
systems with unilateral
constraints

The Moreau's sweeping
process of first order

Dynamical Complementarity
Systems (DCS)

Other NSDS: A very short
zoology

Higher order relative degree
systems

References

Definition (RCBV sweeping process (KUNZE & MONTEIRO MARQUES, 1998))

The RCBV sweeping process of the type is defined

$$\begin{cases} -du \in N_{K(t)}(u(t)) \quad (t \geq 0), \\ u(0) = u_0. \end{cases} \quad (42)$$

where the convex set is RCBV i.e

$$d_H(K(t), K(s)) \leq r(t) - r(s) \quad (43)$$

for some right-continuous non-decreasing function $r : [0, T] \rightarrow \mathbb{R}$ is made.

Mathematical properties

- the solution $u(\cdot)$ is searched as a function of bounded variations (B.V.)
- the measure du associated with the B.V. function u is a differential measure or a Stieltjes measure.
- Inclusion of measure into cone

Definition (Unbounded Differential Inclusion (UDI))

The following UDI can be defined (together with the initial condition $x(0) = x_0 \in C$)

$$-(\dot{x}(t) + f(x(t)) + g(t)) \in \mathbb{N}_K(x(t)) \quad (44)$$

where K is the feasible set and $g : \mathbb{R}_+ \rightarrow \mathbb{R}^n$ and $f : \mathbb{R}^n \rightarrow \mathbb{R}^n$.

Basic properties

- A solution of such a UDI is understood as an absolutely continuous $t \mapsto x(t)$ lying in the convex set C .

Comment

The Terminology is explained by the fact that $\mathbb{N}_K(x(t))$ is neither compact nor bounded. Standard DI analysis no longer apply.

Link with Maximal monotone operator

- In (BREZIS, 1973), a existence and uniqueness theorem for

$$\dot{x}(t) + A(x(t)) + g(t) \ni 0 \quad (45)$$

where A is a maximal monotone operator, and g a absolutely continuous function of time.

- If f which is monotone and Lipschitz continuous, then

$$A(x(t)) = f(x(t)) + \mathbb{N}_K(x(t)) \quad (46)$$

is then a maximal monotone operator.

- Equivalence (BROGLIATO *et al.*, 2006)

$$- (\dot{x}(t) + f(x(t)) + g(t)) \in \mathbb{N}_{T_K(x(t))}(\dot{x}(t)), \quad (47)$$

providing that the UDI (44) has the so-called slow solution, that is $\dot{x}(t)$ is of minimal norm in $\mathbb{N}_{K(x(t))}(x(t)) + f(x, t) + g(t)$.

Special case when K is finitely represented.

Lecture 1. Formulations of Non Smooth Dynamical Systems (NSDS).

Vincent Acary

Outline

Lagrangian dynamical systems with unilateral constraints

The Moreau's sweeping process of first order

Dynamical Complementarity Systems (DCS)

Other NSDS: A very short zoology

Higher order relative degree systems

References

Assumptions

$$K = \{x \in \mathbb{R}^n, h(x) \leq 0\} \quad (48)$$

For $x \in K$, we denote by

$$I(x) = \{i \in \{1 \dots m\}, h_i(x) = 0\} \quad (49)$$

the set of active constraints at x . The tangent cone can be defined by

$$T^h(x) = \{s \in \mathbb{R}^n, \langle \nabla h_i(x), s \rangle \leq 0, i \in I(x)\} \quad (50)$$

and the normal cone by

$$N^h(x) := [T^h(x)]^\circ = \left\{ \sum_{i \in I(x)} \lambda_i \nabla h_i(x), \lambda_i \geq 0, i \in I(x) \right\} \quad (51)$$

- $N_K(x) \supset N^h(x)$ and $T_K(x) \subset T^h(x)$ always hold.
- $N_K = N^h$ and equivalently $T_K = T^h$ holds if a constraints qualification condition is satisfied

Special case when K is finitely represented.

Lecture 1. Formulations of Non Smooth Dynamical Systems (NSDS).

Vincent Acary

Outline

Lagrangian dynamical systems with unilateral constraints

The Moreau's sweeping process of first order

Dynamical Complementarity Systems (DCS)

Other NSDS: A very short zoology

Higher order relative degree systems

References

Link with Differential Complementarity Systems (DCS)

Equivalence with the following DCS of Gradient Type (GTCS)

$$\begin{cases} -\dot{x}(t) = f(x(t)) + g(t) + \nabla h(x(t))\lambda(t) \\ 0 \leq -h(x(t)) \perp \lambda(t) \geq 0 \end{cases} \quad (48)$$

Link with Evolution Variational Inequalities (EVI)

Equivalence with the following EVI

$$\langle \dot{x}(t) + f(x(t)) + g(t), y - x \rangle \geq 0 \quad (49)$$

- existence and uniqueness theorem for maximal monotone operators
- existence result is given for this last EVI under the assumption that f is continuous and hypo-monotone (BROGLIATO *et al.*, 2006).

Lecture 1. Formulations of Non Smooth Dynamical Systems (NSDS).

Vincent Acary

Outline

Lagrangian dynamical systems with unilateral constraints

The Moreau's sweeping process of first order

Dynamical Complementarity Systems (DCS)

Other NSDS: A very short zoology

Higher order relative degree systems

References

- Quasi-static analysis (first order) of viscoelastic mechanical systems
 - with perfect (associated) plasticity
 - with associated friction
- Quasi static analysis (first order) of quasi-brittle mechanical systems
 - cohesion, damage and fracture mechanics
 - geomaterials

1 Outline

2 Lagrangian dynamical systems with unilateral constraints

- The smooth multibody dynamics
- The Non smooth Lagrangian Dynamics
- The Moreau's sweeping process

3 The Moreau's sweeping process of first order

4 Dynamical Complementarity Systems (DCS)

- Definitions
- The notion of relative degree. Well-posedness
- The LCS of relative degree $r \leq 1$. The passive LCS

5 Other Non Smooth Dynamical systems: A very short zoology

- Differential inclusions (DI)
- Evolution Variational inequalities (EVI)
- Differential Variational Inequalities (DVI)
- Projected Dynamical Systems (PDS)
- Piece-Wise affine (PWA) and piece-wise continuous (PWC) systems
- And other systems

6 Higher order relative degree systems

Definition (Generalized Dynamical Complementarity Systems (GDCS) (semi-explicit form))

A generalized Dynamical Complementarity System (DCS) in a semi-explicit form is defined by

$$\begin{cases} \dot{x} = f(x, t, \lambda) \\ y = h(x, \lambda) \\ C^* \ni y \perp \lambda \in C \end{cases} \quad (50)$$

where C and C^* are a pair of dual closed convex cones ($C^* = -C^\circ$).

Definition (Dynamical Complementarity Systems (DCS))

A Dynamical Complementarity System (DCS) in an explicit form is defined by

$$\begin{cases} \dot{x} = f(x, t, \lambda) \\ y = h(x, \lambda) \\ 0 \leq y \perp \lambda \geq 0 \end{cases} \quad (51)$$

Lecture 1. Formulations of Non Smooth Dynamical Systems (NSDS).

Vincent Acary

Outline

Lagrangian dynamical systems with unilateral constraints

The Moreau's sweeping process of first order

Dynamical Complementarity Systems (DCS)

Definitions

The notion of relative degree. Well-posedness

The LCS of relative degree $r \leq 1$. The passive LCS

Other NSDS: A very short zoology

Higher order relative degree systems

References

Definition (Linear Complementarity Systems (LCS))

A Linear Complementarity System (LCS) is defined by

$$\begin{cases} \dot{x} = Ax + B\lambda \\ y = Cx + D\lambda \\ 0 \leq y \perp \lambda \geq 0 \end{cases} \quad (50)$$

Definition (Non Linear complementarity systems (NLCS))

A Non Linear Complementarity System usually (NLCS) is defined by the following system:

$$\begin{cases} \dot{x} = f(x, t) + g(x)^T \lambda \\ y = h(x, \lambda) \\ 0 \leq y \perp \lambda \geq 0 \end{cases} \quad (50)$$

Definition (Gradient Type Complementarity Problem (GTCS))

A Gradient Type Complementarity Problem (GTCS) is defined by the following system:

$$\begin{cases} \dot{x}(t) + f(x(t)) = \nabla_x^T g(x) \lambda \\ y = g(x(t)) \\ 0 \leq y \perp \lambda \geq 0 \end{cases} \quad (51)$$

Definition (Relative degree in the SISO case)

Let us consider a linear system in state representation given by the quadruplet $(A, B, C, D) \in \mathbb{R}^{n \times n} \times \mathbb{R}^{n \times m} \times \mathbb{R}^{m \times n} \times \mathbb{R}^{m \times m}$:

$$\begin{cases} \dot{x} = Ax + B\lambda \\ y = Cx + D\lambda \end{cases} \quad (52)$$

- In the Single Input/ Single Output (SISO) case ($m = 1$), the relative degree is defined by the first non zero Markov parameters :

$$D, CB, CAB, CA^2B, \dots, CA^{r-1}B, \dots \quad (53)$$

- In the multiple input/multiple output (MIMO) case ($m > 1$), an *uniform* relative degree is defined as follows. If D is non singular, the relative degree is equal to 0. Otherwise, it is assumed to be the first positive integer r such that

$$CA^i B = 0, \quad i = 0 \dots r-2 \quad (54)$$

while

$$CA^{r-1}B \text{ is non singular.} \quad (55)$$

Interpretation

The Markov parameters arise naturally when we derive with respect to time the output y ,

$$y = Cx + D\lambda$$

$$\dot{y} = CAx + CB\lambda, \text{ if } D = 0$$

$$\ddot{y} = CA^2x + CAB\lambda, \text{ if } D = 0, CB = 0$$

...

$$y^{(r)} = CA^r x + CA^{r-1} B \lambda, \text{ if } D = 0, CB = 0, CA^{r-2} B = 0, r = 1 \dots r-2$$

...

and the first non zero Markov parameter allows us to define the output y directly in terms of the input λ .

The notion of relative degree. Well-posedness

Lecture 1. Formulations of Non Smooth Dynamical Systems (NSDS).

Vincent Acary

Outline

Lagrangian dynamical systems with unilateral constraints

The Moreau's sweeping process of first order

Dynamical Complementarity Systems (DCS)

Definitions

The notion of relative degree. Well-posedness

The LCS of relative degree $r \leq 1$. The passive LCS

Other NSDS: A very short zoology

Higher order relative degree systems

References

Example

Third relative degree LCS Let us consider the following LCS:

$$\begin{cases} \ddot{x}(t) = \lambda, x(0) = x_0 \geq 0 \\ y(t) = x(t) \\ 0 \leq y \perp \lambda \geq 0 \end{cases} \quad (52)$$

The function $x : [0, T] \rightarrow \mathbb{R}$ is usually assumed to be an absolutely continuous function of time.

- If $y = x \geq 0$ becomes active, i.e., $x = 0$,
 - If $\dot{x} > 0$, the system will instantaneously leaves the constraints.
 - If $\dot{x} < 0, \ddot{x} > 0$, the velocity needs to jump to respect the constraint in t^+ . (B.V. function ?)
 - If $\dot{x} < 0, \ddot{x} < 0$, the velocity and the acceleration need to jump to respect the constraint in t^+ . (Dirac + B.V. function)
- $\ddot{x} < 0$ and therefore λ may be derivative of Dirac distribution.

Problem: From the mathematical point of view, a constraint of the type $\lambda \geq 0$ has no mathematical meaning !!

Restrictions

→ In this lecture, we will focus on LCS of relative degree $r \leq 1$.

The passive LCS.

Lecture 1. Formulations of Non Smooth Dynamical Systems (NSDS).

Vincent Acary

Outline

Lagrangian dynamical systems with unilateral constraints

The Moreau's sweeping process of first order

Dynamical Complementarity Systems (DCS)

Definitions

The notion of relative degree. Well-posedness

The LCS of relative degree $r \leq 1$. The passive LCS

Other NSDS: A very short zoology

Higher order relative degree systems

References

Relative degree 0

Let us consider a LCS of relative degree 0 i.e. with D which is non singular.

$$\begin{cases} \dot{x} = Ax + B\lambda, & x(0) = x_0 \\ y = Cx + D\lambda \\ 0 \leq y \perp \lambda \geq 0 \end{cases} \quad (53)$$

Mathematical properties

D is non singular \rightarrow poor interest

■ Existence and Uniqueness.

- "B.SOL(Cx, D) is a singleton":
 $B.SOL(Cx_0, D)$ is a singleton is equivalent to stating that the LCS (57) has a unique C^1 solution defined at all $t \geq 0$.
Denoting by $\Lambda(x) = B.SOL(Cx, D)$, the LCS can be viewed as a standard ODE with a Lipschitz r.h.s :

$$\dot{x} = Ax + \Lambda(x) = Ax + B.SOL(Cx, D) \quad (54)$$

- Special important case: D is a P-matrix, ($LCP(q, M)$ has a unique solution for all $q \in \mathbb{R}^n$ if M is a P-matrix.) The Lipschitz property of the LCP solution with the respect to x is shown in COTTLE *et al.* (1992).
- Stability theory (CAMLIBEL *et al.*, 2006) and for the numerical integration, the problem is a little more tricky because $\Lambda(x)$ is only B-differentiable.

Example

To complete this section, an example of non existence and non uniqueness of solutions is provided for a LCS of relative degree 0. This example is taken from HEEMELS & BROGLIATO (2003). Let us consider the following LCS

$$\begin{cases} \dot{x} = -x + \lambda \\ y = x - \lambda \\ 0 \leq y \perp \lambda \geq 0 \end{cases} \quad (55)$$

This system is strictly equivalent to

$$\dot{x} = \begin{cases} -x, & \text{if } x \geq 0 \\ 0, & \text{if } x < 0 \end{cases} \quad (56)$$

which leads to non existence of solutions for $x(0) < 0$ and to non uniqueness for $x(0) > 0$.

Relative degree 1

Let us consider a LCS of relative degree 1 i.e. with CB which is non singular.

$$\begin{cases} \dot{x} = Ax + B\lambda, & x(0) = x_0 \\ y = Cx \\ 0 \leq y \perp \lambda \geq 0 \end{cases} \quad (57)$$

Mathematical properties

- The Rational Complementarity problem HEEMELS (1999) ; CAMLIBEL (2001) ; CAMLIBEL *et al.* (2002). The P-matrix property plays henceforth a fundamental role and provides the existence of global solution of the LCS in the sense of Caratheodory.
- Special case $B = C^T$ uses some EVI results for the well-posedness and the stability of such a systems (GOELEVELN & BROGLIATO, 2004).

The passive LCS.

Lecture 1. Formulations of Non Smooth Dynamical Systems (NSDS).

Vincent Acary

Outline

Lagrangian dynamical systems with unilateral constraints

The Moreau's sweeping process of first order

Dynamical Complementarity Systems (DCS)

Definitions

The notion of relative degree. Well-posedness

The LCS of relative degree $r \leq 1$. The passive LCS

Other NSDS: A very short zoology

Higher order relative degree systems

References

Comments

The passive linear systems are a class for which a “stored energy” in the system is only decreasing (see for more details, (CAMLIBEL, 2001 ; HEEMELS & BROGLIATO, 2003)). The passive linear systems are of relative degree ≥ 1 .

The passive LCS.

Lecture 1. Formulations of Non Smooth Dynamical Systems (NSDS).

Vincent Acary

Outline

Lagrangian dynamical systems with unilateral constraints

The Moreau's sweeping process of first order

Dynamical Complementarity Systems (DCS)

Definitions

The notion of relative degree. Well-posedness

The LCS of relative degree $r \leq 1$. The passive LCS

Other NSDS: A very short zoology

Higher order relative degree systems

References

Example (The RLC circuit with a diode)

A LC oscillator supplying a load resistor through a half-wave rectifier (see figure 1).

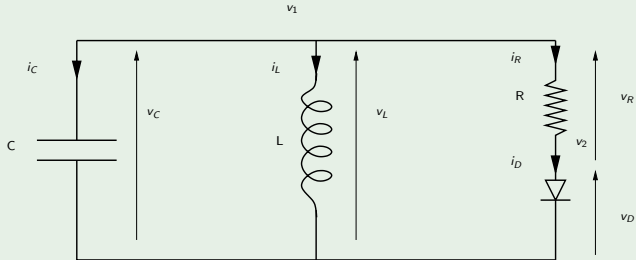

Figure: Electrical oscillator with half-wave rectifier

Example (The RLC circuit with a diode)

- Kirchhoff laws :

$$v_L = v_C$$

$$v_R + v_D = v_C$$

$$i_C + i_L + i_R = 0$$

$$i_R = i_D$$

- Branch constitutive equations for linear devices are :

$$i_C = C\dot{v}_C$$

$$v_L = L\dot{i}_L$$

$$v_R = Ri_R$$

- "branch constitutive equation" of the ideal diode

$$0 \leq i_D \perp -v_D \geq 0$$

The passive LCS.

Lecture 1. Formulations of Non Smooth Dynamical Systems (NSDS).

Vincent Acary

Outline

Lagrangian dynamical systems with unilateral constraints

The Moreau's sweeping process of first order

Dynamical Complementarity Systems (DCS)

Definitions

The notion of relative degree. Well-posedness

The LCS of relative degree $r \leq 1$. The passive LCS

Other NSDS: A very short zoology

Higher order relative degree systems

References

Example (The RLC circuit with a diode)

The following LCS is obtained :

$$\begin{pmatrix} \dot{v}_L \\ \dot{i}_L \end{pmatrix} = \begin{pmatrix} 0 & \frac{-1}{C} \\ \frac{1}{L} & 0 \end{pmatrix} \cdot \begin{pmatrix} v_L \\ i_L \end{pmatrix} + \begin{pmatrix} \frac{-1}{C} \\ 0 \end{pmatrix} \cdot i_D$$

together with a state variable x and one of the complementary variables λ :

$$x = \begin{pmatrix} v_L \\ i_L \end{pmatrix}$$

and

$$\lambda = i_D$$

1 Outline

2 Lagrangian dynamical systems with unilateral constraints

- The smooth multibody dynamics
- The Non smooth Lagrangian Dynamics
- The Moreau's sweeping process

3 The Moreau's sweeping process of first order

4 Dynamical Complementarity Systems (DCS)

- Definitions
- The notion of relative degree. Well-posedness
- The LCS of relative degree $r \leq 1$. The passive LCS

5 Other Non Smooth Dynamical systems: A very short zoology

- Differential inclusions (DI)
- Evolution Variational inequalities (EVI)
- Differential Variational Inequalities (DVI)
- Projected Dynamical Systems (PDS)
- Piece-Wise affine (PWA) and piece-wise continuous (PWC) systems
- And other systems

6 Higher order relative degree systems

Definition

A differential inclusion (DI) may be defined by

$$\dot{x}(t) \in F(x(t)), t \in [0, T] \quad (58)$$

where

- $x(t) : \mathbb{R} \rightarrow \mathbb{R}^n$ is a function of time t ,
- $\dot{x}(t) : \mathbb{R} \rightarrow \mathbb{R}^n$ is the time derivative,
- $F : \mathbb{R} \rightarrow \mathbb{R}^n$ is a set-valued map which associates to any point $x \in \mathbb{R}^n$ a set $F(x) \subset \mathbb{R}^n$.

Standard classes of DI

- Lipschitzian DI
- Upper semi-continuous DI

Standard references

(AUBIN & CELLINA, 1984 ; DEIMLING, 1992 ; SMIRNOV, 2002)

Differential inclusions (DI)

Lecture 1. Formulations of Non Smooth Dynamical Systems (NSDS).

Vincent Acary

Outline

Lagrangian dynamical systems with unilateral constraints

The Moreau's sweeping process of first order

Dynamical Complementarity Systems (DCS)

Other NSDS: A very short zoology

Differential inclusions (DI)

Evolution Variational inequalities (EVI)

Differential Variational Inequalities (DVI)

Projected Dynamical Systems (PDS)

Piece-Wise affine (PWA) and piece-wise continuous (PWC) systems

And other systems

Higher order relative degree systems

References

Example

Ordinary Differential Equation (ODE)

$$\dot{x} = f(x, t), \quad (59)$$

considering the singleton $F(x) = \{f(x, t)\}$

Example

Implicit Differential Equation (IDE),

$$f(\dot{x}, x) = 0 \quad (60)$$

defining the set-valued map as $F(x) = \{v, f(v, x) = 0\}$

Differential inclusions (DI)

Lecture 1. Formulations of Non Smooth Dynamical Systems (NSDS).

Vincent Acary

Outline

Lagrangian dynamical systems with unilateral constraints

The Moreau's sweeping process of first order

Dynamical Complementarity Systems (DCS)

Other NSDS: A very short zoology

Differential inclusions (DI)

Evolution Variational inequalities (EVI)

Differential Variational Inequalities (DVI)

Projected Dynamical Systems (PDS)

Piece-Wise affine (PWA) and piece-wise continuous (PWC) systems
And other systems

Higher order relative degree systems

References

Example

ODE with discontinuous right hand side (r.h.s.),

$$\dot{x}(t) = f(x(t)), t \in [0, T] \quad (61)$$

with

$$f(x, t) = \begin{cases} 1, & \text{if } x < 0 \\ -1, & \text{if } x \geq 0 \end{cases} \quad (62)$$

Filippov DI :

$$\dot{x}(t) \in F(x) = \bigcap_{\varepsilon > 0} \overline{\text{conv}} f(x + \varepsilon B_n) \quad (63)$$

where B_n is the unit ball of \mathbb{R}^n .

Why DIs are Non Smooth Dynamical systems ?

- Extensive use of Non Smooth and Set-valued Analysis.
- Non smoothness of solution due to constraints on \dot{x}
 - $x(t)$ is usually absolutely continuous
 - $\dot{x}(t)$ is usually non smooth (\mathcal{L}^1 , B.V. functions)

Definition (Lipschitzian DI)

A DI is said to be a Lipschitzian DI if the set-valued map $F : \mathbb{R} \rightarrow \mathbb{R}^n$ satisfies the following condition:

- 1 the sets $F(x)$ are closed and convex for all $x \in \mathbb{R}^n$;
- 2 the set-valued map F is Lipschitzian with a constant l , i.e.

$$\exists l \geq 0, \quad F(x_1) \subset F(x_2) + l \|x_1 - x_2\| B_n \quad (64)$$

where B_n is the unit ball of \mathbb{R}^n ,

Example (Control theory)

- ODE with control input

$$\dot{x} = f(x, u), t \in [0, T], x(0) = x_0 \quad u \in U \subset \mathbb{R}^m \quad (65)$$

where $f : \mathbb{R}^n \times U \rightarrow \mathbb{R}^n$ is assumed to be a continuous function satisfying a Lipschitz condition in x .

- Associated Lipschitzian DI

$$\dot{x} \in \cup_{u \in U} f(x, u) \quad (66)$$

Assume that the set $f(x, U)$ is closed and convex for all $x \in \mathbb{R}^n$, the solution of the Cauchy problem (65) is a solution of the DI (66) and due to a result of Filippov, the converse statement is also true in the sense that there exists a solution $v(t)$ of the inclusion (66) which is also a solution of (65).

Definition (Upper semi-continuous DI)

A DI is said to be an upper semi-continuous DI if the set-valued map $F : \mathbb{R} \rightarrow \mathbb{R}^n$ satisfies the following condition:

- 1 the sets $F(x)$ are closed and convex for all $x \in \mathbb{R}^n$;
- 2 the set-valued map F is upper semi-continuous for all $x \in \mathbb{R}$, i.e, if for every open set M containing $F(x)$, $x \in \mathbb{R}$ there exists a neighborhood Ω of x such that $F(\Omega) \subset M$.

An example of upper semi-continuous DI: the Filippov DI

$$\dot{x}(t) = f(x(t)), t \in [0, T], \quad x(0) = x_0 \quad (67)$$

where $f : \mathbb{R}^n \rightarrow \mathbb{R}^n$ is a bounded function.

If f is not continuous, then the Cauchy problem associated with this ODE may have no solution.

Filippov DI

$$\dot{x}(t) \in F(x) = \bigcap_{\varepsilon > 0} \overline{\text{conv}f(x + \varepsilon B_n)} \quad (68)$$

where B_n is the unit ball of \mathbb{R}^n .

Example (ODE with a discontinuous r.h.s)

A standard example is given by the following r.h.s:

$$f(x, t) = \begin{cases} 1, & \text{if } x < 0 \\ -1, & \text{if } x \geq 0 \end{cases} \quad (67)$$

Standard solution

$$\begin{cases} x(t) < 0, x(t) = t + x_0 \\ x(t) > 0, x(t) = -t + x_0 \end{cases} \quad (68)$$

Each solution reaches the point $x = 0$ and can not leave it. Unfortunately, the function $x(t) \equiv 0$ does not satisfy the equation, since $\dot{x} = 0 \neq f(0) = -1$.

Filippov DI

$$\dot{x}(t) \in F(x) = \begin{cases} 1, & \text{if } x < 0 \\ -1, & \text{if } x > 0 \\ [-1, 1], & \text{if } x = 0 \end{cases} \quad (69)$$

Variational inequalities (VI)

Lecture 1. Formulations of Non Smooth Dynamical Systems (NSDS).

Vincent Acary

Outline

Lagrangian dynamical systems with unilateral constraints

The Moreau's sweeping process of first order

Dynamical Complementarity Systems (DCS)

Other NSDS: A very short zoology

Differential inclusions (DI)

Evolution Variational inequalities (EVI)

Differential Variational Inequalities (DVI)

Projected Dynamical Systems (PDS)

Piece-Wise affine (PWA) and piece-wise continuous (PWC) systems

And other systems

Higher order relative degree systems

References

Definition (Variational Inequality (VI) problem)

Let X be a nonempty subset of \mathbb{R}^n and let F be a mapping from \mathbb{R}^n into itself. The Variational Inequality problem, denoted by $VI(X, F)$ is to find a vector $z \in \mathbb{R}^n$ such that

$$F(z)^T(y - z) \geq 0, \forall y \in X \quad (70)$$

Equivalences and others definitions

- Inclusion into a normal cone.

$$-F(x) \in N_X(x) \quad (71)$$

or equivalently

$$0 \in F(x) + N_X(x) \quad (72)$$

- If F is affine function, $F(x) = Mz + q$, the $VI(X, F)$ is called Affine VI denoted by, $AVI(X, F)$.
- If X is polyhedral, we say that the $VI(X, F)$ is linearly constrained.

Definition (Evolution Variational Inequalities (EVI))

An Evolution Variational Inequality (EVI) is defined by finding $x \in K$ such that

$$\langle \dot{x} + f(x), y - x \rangle \geq 0, \forall y \in K \quad (73)$$

which is equivalent to the following unbounded DI

$$- (\dot{x} + f(x)) \in \mathbb{N}_K(x) \quad (74)$$

References

- Infinite-dimensional spaces. (LIONS & STAMPACCHIA, 1967 ; KINDERLEHRER & STAMPACCHIA, 1980 ; GOELEN *et al.*, 2003)
- Finite-dimensional spaces. (HARKER & PANG, 1990 ; FACCHINEI & PANG, 2003)

Mathematical properties

- Through the reformulation (44), existence and uniqueness theorem for maximal monotone operators holds for

$$\langle \dot{x}(t) + f(x(t)) + g(t), y - x \rangle \geq 0 \quad (75)$$

In (BROGLIATO *et al.*, 2006), a existence result is given under the assumption that f is continuous and hypo-monotone.

Other definitions

- For $g \equiv 0$ and $f(x) = Ax$, the EVI is called a Linear Evolution Variational Inequality (LEVI).
- If the set K depends on x , i.e. $K(x)$, we speak of Evolution Quasi-Variational inequality (EQVI)

$$\langle \dot{x} + f(x), y - x \rangle \geq 0, \forall y \in K(x) \quad (76)$$

Differential Variational Inequalities (DVI)

Lecture 1. Formulations of Non Smooth Dynamical Systems (NSDS).

Vincent Acary

Outline

Lagrangian dynamical systems with unilateral constraints

The Moreau's sweeping process of first order

Dynamical Complementarity Systems (DCS)

Other NSDS: A very short zoology

Differential inclusions (DI)
Evolution Variational inequalities (EVI)

Differential Variational Inequalities (DVI)

Projected Dynamical Systems (PDS)

Piece-Wise affine (PWA) and piece-wise continuous (PWC) systems

And other systems

Higher order relative degree systems

References

Definition (Differential Variational inequalities (DVI) (PANG, 2006))

A Differential Variational inequality can be defined as follows:

$$\dot{x}(t) = f(t, x(t), u(t)) \quad (77)$$

$$u(t) = \text{SOL}(K, F(t, x(t), \cdot)) \quad (78)$$

$$0 = \Gamma(x(0), x(T)) \quad (79)$$

where :

- $x : [0, T] \rightarrow \mathbb{R}^n$ is the differential trajectory (state variable),
- $u : [0, T] \rightarrow \mathbb{R}^m$ is the algebraic trajectory
- $f : [0, T] \times \mathbb{R}^n \times \mathbb{R}^m \rightarrow \mathbb{R}^n$ is the ODE right-hand side
- $F : [0, T] \times \mathbb{R}^n \times \mathbb{R}^m \rightarrow \mathbb{R}^m$ is the VI function
- K is nonempty closed convex subset of \mathbb{R}^m
- $\Gamma : \mathbb{R}^n \times \mathbb{R}^n \rightarrow \mathbb{R}^n$ is the boundary conditions function.
 - Initial Value Problem (IVP), $\Gamma(x, y) = x - x_0$
 - linear Boundary Value Problem (BVP), $\Gamma(x, y) = Mx + Ny - b$

The notation $u(t) = \text{SOL}(K, \Phi)$ means that $u(t) \in K$ is the solution of the following VI

$$(v - u)^T \Phi(u) \geq 0, \quad \forall v \in K \quad (80)$$

The DVI is a slightly more general framework in the sense that it includes at the same time:

■ Differential Algebraic equations(DAE)

$$\dot{x}(t) = f(t, x(t), u(t)) \quad (81)$$

$$u(t) = F(t, x(t), u(t)) \quad (82)$$

■ Differential Complementarity systems (DCS)

$$\dot{x}(t) = f(t, x(t), u(t)) \quad (83)$$

$$C \ni u(t) \perp F(t, x(t), u(t)) \in C^* \quad (84)$$

where C and C^* are a pair of dual closed convex cones ($C^* = -C^\circ$).
The Linear Complementarity systems are also special case of DVI (see the section 4).

Differential Variational Inequalities (DVI)

Lecture 1. Formulations of Non Smooth Dynamical Systems (NSDS).

Vincent Acary

Outline

Lagrangian dynamical systems with unilateral constraints

The Moreau's sweeping process of first order

Dynamical Complementarity Systems (DCS)

Other NSDS: A very short zoology

Differential inclusions (DI)
Evolution Variational inequalities (EVI)

Differential Variational Inequalities (DVI)

Projected Dynamical Systems (PDS)

Piece-Wise affine (PWA) and piece-wise continuous (PWC) systems
And other systems

Higher order relative degree systems

References

The DVI is a slightly more general framework in the sense that it includes at the same time:

■ Evolution variational inequalities (EVI)

$$-\dot{x} + f(x) \in \mathbb{N}_K(x) \quad (81)$$

- When K is a cone, the preceding EVI is equivalent to a DCS of the type :

$$\dot{x}(t) + f(x(t)) = u(t) \quad (82)$$

$$K \ni x(t) \perp u(t) \in K^* \quad (83)$$

- When K is finitely represented i.e. $K = \{x \in \mathbb{R}^n, g(x) \leq 0\}$ then under some appropriate constraints qualifications, we obtain another DCS which is often called a Gradient type Complementarity Problem (GTCS) (see 4) :

$$\dot{x}(t) + f(x(t)) = -\nabla_x^T g(x)u(t) \quad (84)$$

$$0 \leq -g(x(t)) \perp u(t) \geq 0 \quad (85)$$

- Finally, if K is a closed convex and nonempty set then the EVI is equivalent to the following DVI :

$$\dot{x}(t) + f(x(t)) = w(t) \quad (86)$$

$$0 = x(t) - y(t) \quad (87)$$

$$y(t) \in K, (v - y(t))^T w(t) \geq 0, \forall v \in K \quad (88)$$

Projected Dynamical Systems (PDS)

Lecture 1. Formulations of Non Smooth Dynamical Systems (NSDS).

Vincent Acary

Outline

Lagrangian dynamical systems with unilateral constraints

The Moreau's sweeping process of first order

Dynamical Complementarity Systems (DCS)

Other NSDS: A very short zoology

Differential inclusions (DI)

Evolution Variational inequalities (EVI)

Differential Variational Inequalities (DVI)

Projected Dynamical Systems (PDS)

Piece-Wise affine (PWA) and piece-wise continuous (PWC) systems

And other systems

Higher order relative degree systems

References

Definition (Projected Dynamical Systems (PDS))

Let us consider a nonempty closed and convex subset K of \mathbb{R}^n . A Projected Dynamical System (PDS) is defined as the following system:

$$\dot{x}(t) = \Pi_K(x(t); -(f(x(t)) + g(t))) \quad (89)$$

where $\Pi_K : K \times \mathbb{R}^n \rightarrow \mathbb{R}^n$ is the operator

$$\Pi_K(x; v) = \lim_{\delta \downarrow 0} \frac{\text{proj}_K(x + \delta v) - x}{\delta} \quad (90)$$

Comments

- The definition of the operator Π_K corresponds to the one-sided Gâteaux derivative of the projection operator for $x \in K$, i.e. when $P_K(x) = x$. A classical result of Convex analysis, see for instance (HIRRIART-URRUTY & LEMARECHAL, 1993), states that

$$\Pi_K(x; v) = \text{proj}_{T_K(x)}(v) \quad (91)$$

Therefore, the PDS can be equivalently rewritten as :

$$\dot{x}(t) = \text{proj}_{T_K(x(t))}(-(f(x(t)) + g(t))) \quad (92)$$

Projected Dynamical Systems (PDS)

Lecture 1. Formulations of Non Smooth Dynamical Systems (NSDS).

Vincent Acary

Outline

Lagrangian dynamical systems with unilateral constraints

The Moreau's sweeping process of first order

Dynamical Complementarity Systems (DCS)

Other NSDS: A very short zoology

Differential inclusions (DI)

Evolution Variational inequalities (EVI)

Differential Variational Inequalities (DVI)

Projected Dynamical Systems (PDS)

Piece-Wise affine (PWA) and piece-wise continuous (PWC) systems

And other systems

Higher order relative degree systems

References

Definition (Projected Dynamical Systems (PDS))

Let us consider a nonempty closed and convex subset K of \mathbb{R}^n . A Projected Dynamical System (PDS) is defined as the following system:

$$\dot{x}(t) = \Pi_K(x(t); -(f(x(t)) + g(t))) \quad (89)$$

where $\Pi_K : K \times \mathbb{R}^n \rightarrow \mathbb{R}^n$ is the operator

$$\Pi_K(x; v) = \lim_{\delta \downarrow 0} \frac{\text{proj}_K(x + \delta v) - x}{\delta} \quad (90)$$

Comments

- In (BROGLIATO *et al.*, 2006), the PDS (92) is proved to be equivalent to the UDI(47) and therefore to be equivalent to the UDI (44) if the slow condition is selected.
- For results and definitions in infinite-dimensional spaces (Hilbert spaces), we refer to the work of (COJOCARU, 2002 ; COJOCARU & JONKER, 2003).

Piece-Wise affine (PWA) and piece-wise continuous (PWC) systems

Lecture 1. Formulations of Non Smooth Dynamical Systems (NSDS).

Vincent Acary

Outline

Lagrangian dynamical systems with unilateral constraints

The Moreau's sweeping process of first order

Dynamical Complementarity Systems (DCS)

Other NSDS: A very short zoology

Differential inclusions (DI)

Evolution Variational inequalities (EVI)

Differential Variational Inequalities (DVI)

Projected Dynamical Systems (PDS)

Piece-Wise affine (PWA) and piece-wise continuous (PWC) systems

And other systems

Higher order relative degree systems

References

Definition (Piece-Wise affine (PWA) systems)

A Piece-Wise affine (PWA) system can be defined by systems of the form

$$\dot{x}(t) = A_i x(t) + a_i, \quad x(t) \in X_i \quad (91)$$

where

- $\{X_i\}_{i \in I} \subset \mathbb{R}^n$, partition of the state space in closed (possibly unbounded) polyhedral cells with disjoint interior,
- the matrix $A_i \in \mathbb{R}^{n \times n}$ and the vector $a_i \in \mathbb{R}^n$ defines an affine system on each cell.

Piece-Wise affine (PWA) and piece-wise continuous (PWC) systems

Lecture 1. Formulations of Non Smooth Dynamical Systems (NSDS).

Vincent Acary

Outline

Lagrangian dynamical systems with unilateral constraints

The Moreau's sweeping process of first order

Dynamical Complementarity Systems (DCS)

Other NSDS: A very short zoology

Differential inclusions (DI)

Evolution Variational inequalities (EVI)

Differential Variational Inequalities (DVI)

Projected Dynamical Systems (PDS)

Piece-Wise affine (PWA) and piece-wise continuous (PWC) systems

And other systems

Higher order relative degree systems

References

Nature of solution (JOHANSSON & RANTZER, 1998)

Solution: a continuous piecewise \mathcal{C}^1 function $x(t) \in \cup_{i \in I} X_i$ on the time interval $[0, T]$ with for every $t \in [0, T]$ such the derivative $\dot{x}(t)$ is defined, the equation $\dot{x}(t) = A_i x(t) + a_i$, holds for all i with $x(t) \in X_i$.

Remarks

The definition is relatively rough, but can suffice to understand what type of solutions are sought. Indeed, If some discontinuity of the r.h.s is allowed, the canonical problem with the sign function can be cast into such a formalism. We know that the existence of solution is not guaranteed for such a r.h.s. . The authors JOHANSSON & RANTZER (1998) circumvent this problem excluding arbitrarily such cases. A proper definition of solution could be given by the FILIPPOV (1988) or UTKIN (1977) solutions of the system:

$$\dot{x}(t) = \text{conv}_{j \in J} \{A_j x(t) + a_j\} \text{ with } J = \{j, x(t) \in X_j\} \quad (91)$$

Piece-Wise Continuous (PWC) systems

Lecture 1. Formulations of Non Smooth Dynamical Systems (NSDS).

Vincent Acary

Outline

Lagrangian dynamical systems with unilateral constraints

The Moreau's sweeping process of first order

Dynamical Complementarity Systems (DCS)

Other NSDS: A very short zoology

Differential inclusions (DI)

Evolution Variational inequalities (EVI)

Differential Variational Inequalities (DVI)

Projected Dynamical Systems (PDS)

Piece-Wise affine (PWA) and piece-wise continuous (PWC) systems

And other systems

Higher order relative degree systems

References

Definition (Piece-Wise Continuous (PWC) systems)

A Piece-Wise Continuous (PWC) systems can be defined by

$$\dot{x}(t) = f_i(x, t), \quad x(t) \in X_i \quad (92)$$

where the continuous $f_i : \mathbb{R}^n \times [0, T] \rightarrow \mathbb{R}^n$ defines an continuous system on each cell.

Comments

In a general way, it is difficult to understand what is the interest in PWA and PWC systems without referring to one of the following formalisms

- ODE with Lipschitz r.h.s
- Filippov DI
- Higher order relative degree systems

Lecture 1. Formulations of Non Smooth Dynamical Systems (NSDS).

Vincent Acary

Outline

Lagrangian dynamical systems with unilateral constraints

The Moreau's sweeping process of first order

Dynamical Complementarity Systems (DCS)

Other NSDS: A very short zoology

Differential inclusions (DI)
Evolution Variational inequalities (EVI)

Differential Variational Inequalities (DVI)

Projected Dynamical Systems (PDS)

Piece-Wise affine (PWA) and piece-wise continuous (PWC) systems

And other systems

Higher order relative degree systems

References

- Time varying systems
- Switched systems
- Hybrid systems
- Impulsive Differential Equations
- ...

1 Outline

2 Lagrangian dynamical systems with unilateral constraints

- The smooth multibody dynamics
- The Non smooth Lagrangian Dynamics
- The Moreau's sweeping process

3 The Moreau's sweeping process of first order

4 Dynamical Complementarity Systems (DCS)

- Definitions
- The notion of relative degree. Well-posedness
- The LCS of relative degree $r \leq 1$. The passive LCS

5 Other Non Smooth Dynamical systems: A very short zoology

- Differential inclusions (DI)
- Evolution Variational inequalities (EVI)
- Differential Variational Inequalities (DVI)
- Projected Dynamical Systems (PDS)
- Piece-Wise affine (PWA) and piece-wise continuous (PWC) systems
- And other systems

6 Higher order relative degree systems

Higher order relative degree systems

Lecture 1. Formulations of Non Smooth Dynamical Systems (NSDS).

Vincent Acary

Outline

Lagrangian dynamical systems with unilateral constraints

The Moreau's sweeping process of first order

Dynamical Complementarity Systems (DCS)

Other NSDS: A very short zoology

Higher order relative degree systems

References

References

- (HEEMELS *et al.*, 2000)
- (ACARY *et al.*, 2005)

Lecture 1. Formulations of
Non Smooth Dynamical
Systems (NSDS).

Vincent Acary

Outline

Lagrangian dynamical
systems with unilateral
constraints

The Moreau's sweeping
process of first order

Dynamical Complementarity
Systems (DCS)

Other NSDS: A very short
zoology

**Higher order relative degree
systems**

References

Thank you for your attention.

- V. ACARY, B. BROGLIATO & D. GOELEVELN. Higher order moreau's sweeping process: Mathematical formulation and numerical simulation. *Mathematical Programming A*, 2005.
- J.P. AUBIN & A. CELLINA. *Differential inclusions: set-valued maps and viability theory*. Springer, Berlin, 1984.
- H. BREZIS. *Opérateurs maximaux monotones et semi-groupes de contraction dans les espaces de Hilbert*. North Holland, Amsterdam, 1973.
- B. BROGLIATO, A. DANILIDIS, C. LEMARÉCHAL & V. ACARY. On the equivalence between complementarity systems, projected systems and differential inclusions. *Systems and Control Letters*, 55(1), pp. 45–51, 2006.
- K. CAMLIBEL. *Complementarity Methods in the Analysis of Piecewise Linear Dynamical Systems*. PhD thesis, Katholieke Universiteit Brabant, 2001. ISBN: 90 5668 073X.
- K. CAMLIBEL, W.P.M.H. HEEMELS & J.M. SCHUMACHER. Consistency of a time-stepping method for a class of piecewise-linear networks. *IEEE Transactions on Circuits and Systems I*, 49, pp. 349–357, 2002.
- K. CAMLIBEL, J.S. PANG & J. SHEN. Lyaunov stability of complementarity and extended systems. *SIAM Journal on Optimization*, 2006. in revision.
- F.H. CLARKE. Generalized gradients and its applications. *Transactions of A.M.S.*, 205, pp. 247–262, 1975.

- F.H. CLARKE. *Optimization and Nonsmooth analysis*. Wiley, New York, 1983.
- M.G. COJOCARU. *Projected Dynamical Systems on Hilbert Spaces*. PhD thesis, Departement of Mathematics and Statistics, Quenn's university, Kingston, Ontario, Canada, 2002.
- M.G. COJOCARU & L.B. JONKER. Existence of solutions to projected differential equations on hilbert spaces. *Proceedings of the AMS*, 132 (1), pp. 183–193, 2003.
- R. W. COTTLE, J. PANG & R. E. STONE. *The linear complementarity problem*. Academic Press, Inc., Boston, MA, 1992.
- K. DEIMLING. *Multivalued Differential Equations*. Walter de Gruyter, 1992.
- FRANCISCO FACCHINEI & JONG-SHI PANG. *Finite-dimensional variational inequalities and complementarity problems*, volume I & II of *Springer Series in Operations Research*. Springer Verlag NY. Inc., 2003.
- A. F. FILIPPOV. *Differential equations with discontinuous right hand sides*. Kluwer, Dordrecht, the Netherlands, 1988.
- D. GOELEVELN & B. BROGLIATO. Stability and instability matrices for linear evolution variational inequalities. *IEEE Transactions on Automatic Control*, 49(4), pp. 521–534, 2004.
- D. GOELEVELN, D. MOTREANU, Y. DUMONT & M. ROCHDI. *Variational and Hemivariational Inequalities: Theory, Methods and Applications; Volume I: Unilateral Analysis and Unilateral Mechanics*. Nonconvex Optimization and its Applications. Kluwer Academic Publishers, 2003.

Lecture 1. Formulations of
Non Smooth Dynamical
Systems (NSDS).

Vincent Acary

Outline

Lagrangian dynamical
systems with unilateral
constraints

The Moreau's sweeping
process of first order

Dynamical Complementarity
Systems (DCS)

Other NSDS: A very short
zoology

Higher order relative degree
systems

References

- P.T. HARKER & J.-S. PANG. Finite-dimensional variational inequality and complementarity problems: a survey of theory, algorithms and applications. *Mathematical Programming*, 48, pp. 160–220, 1990.
- W.P.M.H. HEEMELS. *Linear Complementarity Systems. A Study in Hybrid Dynamics*. PhD thesis, Technical University of Eindhoven, 1999. ISBN 90-386-1690-2.
- W.P.M.H. HEEMELS & B. BROGLIATO. The complementarity class of hybrid dynamical systems. *European Journal of Control*, 9, pp. 311–349, 2003.
- W.P.M.H. HEEMELS, J.M. SCHUMACHER & S. WEILAND. Linear complementarity problems. *S.I.A.M. Journal of applied mathematics*, 60 (4), pp. 1234–1269, 2000.
- J.B. HIRRIART-URRUTY & C. LEMARECHAL. *Convex Analysis and Minimization Algorithms*, volume I et II. Springer Verlag, Berlin, 1993.
- M. JOHANSSON & A. RANTZER. Computation of piecewise quadratic lyapunov functions for hybrid systems. *IEEE Transactions on Automatic Control*, 43(4), pp. 555–559, 1998.
- D. KINDERLEHRER & G. STAMPACCHIA. *An Introduction of Variational Inequalities*. Academic Press, New York, 1980.
- M. KUNZE & M.D.P. MONTEIRO MARQUES. On parabolic quasi-variational inequalities and state-dependent sweeping processes. *Topol. Methods Non Linear Analysis*, 12, pp. 179–191, 1998. ▶ ☰ 🔍 ↻

- M. KUNZE & M.D.P. MONTEIRO MARQUES. An introduction to moreau's sweeping process. B. BROGLIATO, editor, *Impact in Mechanical systems: Analysis and Modelling*, volume 551 of *Lecture Notes in Physics*, pp. 1–60. Springer, 2000.
- J.L. LIONS & G. STAMPACCHIA. Variational inequalities. *Communications on Pure and Applied Mathematics*, XX, pp. 493–519, 1967.
- M. D. P. MONTEIRO MARQUES. *Differential Inclusions in NonSmooth Mechanical Problems : Shocks and Dry Friction*. Birkhauser, Verlag, 1993.
- B.S. MORDUKHOVICH. Generalized differential calculus for nonsmooth and set-valued analysis. *Journal of Mathematical analysis and applications*, 183, pp. 250–288, 1994.
- J.J. MOREAU. Raffle par un convexe variable (première partie), exposé no 15. *Séminaire d'analyse convexe, University of Montpellier*, page 43 pages, 1971.
- J.J. MOREAU. Raffle par un convexe variable (deuxième partie) exposé no 3. *Séminaire d'analyse convexe, University of Montpellier*, page 36 pages, 1972.
- J.J. MOREAU. Evolution problem associated with a moving convex set in a Hilbert space. *Journal of Differential Equations*, 26, pp. 347–374, 1977.
- J.J. MOREAU. Liaisons unilatérales sans frottement et chocs inélastiques. *Comptes Rendus de l'Académie des Sciences*, 296 serie II, pp. 1473–1476, 1983.

- J.J. MOREAU. Unilateral contact and dry friction in finite freedom dynamics. J.J. MOREAU & PANAGIOTOPOULOS P.D., editors, *Nonsmooth mechanics and applications*, number 302 in CISM, Courses and lectures, pp. 1–82. CISM 302, Springer Verlag, 1988. Formulation mathématiques tire du livre *Contacts mechanics*.
- D. PANG, J.-S. AN STEWART. Differential variational inequalities. *Mathematical Programming A.*, 2006. submitted, preprint available at <http://www.cis.upenn.edu/davinci/publications/pang-stewart03.pdf>.
- M. SCHATZMAN. Sur une classe de problèmes hyperboliques non linaires. *Comptes Rendus de l'Académie des Sciences Serie A*, 277, pp. 671–674, 1973.
- M. SCHATZMAN. A class of nonlinear differential equations of second order in time. *Nonlinear Analysis, Theory, Methods & Applications*, 2 (3), pp. 355–373, 1978.
- G. SMIRNOV. *Introduction to the theory of Differential inclusions*, volume 41 of *Graduate Studies in Mathematics*. American Mathematical Society, Providence, Rhode Island, 2002.
- V.I. UTKIN. Variable structure systems with sliding modes: A survey. *IEEE Transactions on Automatic Control*, 22, pp. 212–222, 1977.

Lecture 2. Time integration
of Non Smooth Dynamical
Systems (NSDS).

Vincent Acary

Outline

Event-driven schemes

Event-Driven scheme for
Lagrangian dynamical
systems

Time-stepping schemes

References

Lecture 2. Time integration of Non Smooth Dynamical Systems (NSDS).

Vincent Acary

May 31, 2006

1 Outline

2 Event-driven schemes

- Principle

3 Event-Driven scheme for Lagrangian dynamical systems

- The smooth dynamics and the impact equations
- Reformulations of the unilateral constraints on Different kinematics levels
- Reformulations of the smooth dynamics at acceleration level.
- The case of a single contact.
- The multi-contact case and the index-sets
- Comments and extensions

4 Time-stepping schemes

- Principle
- The Moreau's catching-up algorithm for the first order sweeping process
- Time stepping scheme for Linear Complementarity Systems (LCS)
- Time stepping scheme for Differential Variational Inequalities (DVI)

Time-decomposition of the dynamics in

- *modes*, time-intervals in which the dynamics is smooth,
- discrete events, times where the dynamics is nonsmooth.

The following assumptions guarantee the existence and the consistency of such a decomposition

- The definition and the localization of the discrete events. The set of events is negligible with the respect to Lebesgue measure.
- The definition of time-intervals of non-zero lengths. the events are of finite number and "well-separated" in time. Problems with finite accumulations of impacts, or Zeno-state

Comments

On the numerical point of view, we need

- detect events with for instance root-finding procedure.
 - Dichotomy and interval arithmetic
 - Newton procedure for C^2 function and polynomials
- solve the non smooth dynamics at events with a reinitialization rule of the state,
- integrate the smooth dynamics between two events with any ODE solvers.

The smooth dynamics and the impact equations

Lecture 2. Time integration of Non Smooth Dynamical Systems (NSDS).

Vincent Acary

Outline

Event-driven schemes

Event-Driven scheme for Lagrangian dynamical systems

The smooth dynamics and the impact equations

Reformulations of the unilateral constraints on Different kinematics levels

Reformulations of the smooth dynamics at acceleration level.

The case of a single contact.

The multi-contact case and the index-sets

Comments and extensions

Time-stepping schemes

References

The impact equations

The impact equations can be written at the time, t_i of discontinuities:

$$M(q(t_i))(v^+(t_i) - v^-(t_i)) = p_i, \quad (1)$$

This equation will be solved at the time of impact together with an impact law. That is for an Newton impact law

$$\begin{cases} M(q(t_i))(v^+(t_i) - v^-(t_i)) = p_i, \\ U_N^+(t_i) = \nabla_q h(q(t_i))v^+(t_i) \\ U_N^-(t_i) = \nabla_q h(q(t_i))v^-(t_i) \\ p_i = \nabla_q^T h(q(t_i))P_{N,i} \\ 0 \leq U_N^+(t_i) + eU_N^-(t_i) \perp P_{N,i} \geq 0 \end{cases} \quad (2)$$

This problem can be reduced on the local unknowns $U_N^+(t_i), P_{N,i}$ if the matrix $M(q(t_i))$ is assumed to be invertible. One obtains the following LCP at time t_i of discontinuities of v :

$$\begin{cases} U_N^+(t_i) = \nabla_q h(q(t_i))(M(q(t_i)))^{-1} \nabla_q^T h(q(t_i))P_{N,i} + U_N^-(t_i) \\ 0 \leq U_N^+(t_i) + eU_N^-(t_i) \perp P_{N,i} \geq 0 \end{cases} \quad (3)$$

The smooth dynamics and the impact equations

Lecture 2. Time integration
of Non Smooth Dynamical
Systems (NSDS).

Vincent Acary

Outline

Event-driven schemes

Event-Driven scheme for
Lagrangian dynamical
systems

**The smooth dynamics and
the impact equations**

Reformulations of the
unilateral constraints on
Different kinematics levels

Reformulations of the
smooth dynamics at
acceleration level.

The case of a single contact.

The multi-contact case and
the index-sets

Comments and extensions

Time-stepping schemes

References

The smooth dynamics

The following smooth system are then to be solved ($dt - a.e.$) :

$$\begin{cases} M(q(t))\gamma^+(t) + F(t, q, v^+) = f^+(t) \\ g = g(q(t)) \\ f^+ = \nabla_q g(q(t))^T F^+(t) \\ 0 \leq g \perp F^+(t) \geq 0 \end{cases} \quad (1)$$

Reformulations of the unilateral constraints on Different kinematics levels

Lecture 2. Time integration of Non Smooth Dynamical Systems (NSDS).

Vincent Acary

Outline

Event-driven schemes

Event-Driven scheme for Lagrangian dynamical systems

The smooth dynamics and the impact equations

Reformulations of the unilateral constraints on Different kinematics levels

Reformulations of the smooth dynamics at acceleration level.

The case of a single contact.

The multi-contact case and the index-sets

Comments and extensions

Time-stepping schemes

References

Differentiation of the constraints w.r.t time

The constraints $g = g(q(t))$ can be differentiated with respect to time as follows in the Lagrangian setting:

$$\begin{cases} \dot{g}^+ = U_N^+ = \nabla_q g(q) v^+ \\ \ddot{g}^+ = \dot{U}_N^+ = \Gamma_N = \nabla_q g(q) \dot{\gamma}^+ + \nabla_q \dot{g}(q) v^+ \end{cases} \quad (2)$$

Comments

Solving the smooth dynamics requires that the complementarity condition $0 \leq g \perp F^+(t) \geq 0$ must be written now at different kinematic level, i.e. in terms of right velocity U_N^+ and in terms of accelerations Γ_N^+ .

Reformulations of the unilateral constraints on Different kinematics levels

Lecture 2. Time integration of Non Smooth Dynamical Systems (NSDS).

Vincent Acary

Outline

Event-driven schemes

Event-Driven scheme for Lagrangian dynamical systems

The smooth dynamics and the impact equations

Reformulations of the unilateral constraints on Different kinematics levels

Reformulations of the smooth dynamics at acceleration level.

The case of a single contact.

The multi-contact case and the index-sets

Comments and extensions

Time-stepping schemes

References

At the velocity level

Assuming that U_N^+ is right-continuous by definition of the right limit of a B.V. function, the complementarity condition implies, in terms of velocity, the following relation,

$$-F^+ \in \begin{cases} 0 & \text{if } g > 0 \\ 0 & \text{if } g = 0, U_N^+ > 0 \\] -\infty, 0] & \text{if } g = 0, U_N^+ = 0 \end{cases} . \quad (3)$$

A rigorous proof of this assertion can be found in GLOCKER (2001).

Equivalent formulations

- Inclusion into $N_{\mathbb{R}^+}(U_N^+)$

$$-F^+ \in \begin{cases} 0 & \text{if } g > 0 \\ N_{\mathbb{R}^+}(U_N^+) & \text{if } g = 0 \end{cases} \quad (3)$$

- Inclusion into $N_{T_{\mathbb{R}^+(g)}}(U_N^+)$

$$-F^+ \in N_{T_{\mathbb{R}^+(g)}}(U_N^+) \quad (4)$$

- In a complementarity formalism

$$\begin{aligned} \text{if } g = 0 & \quad 0 \leq U_N^+ \perp F^+ \geq 0 \\ \text{if } g > 0 & \quad F^+ = 0 \end{aligned} \quad (5)$$

Reformulations of the unilateral constraints on Different kinematics levels

Lecture 2. Time integration of Non Smooth Dynamical Systems (NSDS).

Vincent Acary

Outline

Event-driven schemes

Event-Driven scheme for Lagrangian dynamical systems

The smooth dynamics and the impact equations

Reformulations of the unilateral constraints on Different kinematics levels

Reformulations of the smooth dynamics at acceleration level.

The case of a single contact.

The multi-contact case and the index-sets

Comments and extensions

Time-stepping schemes

References

At the acceleration level

In the same way, the complementarity condition can be written at the acceleration level as follows.

$$-F^+ \in \begin{cases} 0 & \text{if } g > 0 \\ 0 & \text{if } g = 0, U_N^+ > 0 \\ 0 & \text{if } g = 0, U_N^+ = 0, \Gamma_N > 0 \\] -\infty, 0] & \text{if } g = 0, U_N^+ = 0, \Gamma_N = 0 \end{cases} \quad (6)$$

A rigorous proof of this assertion can be found in GLOCKER (2001).

Reformulations of the unilateral constraints on Different kinematics levels

Lecture 2. Time integration of Non Smooth Dynamical Systems (NSDS).

Vincent Acary

Outline

Event-driven schemes

Event-Driven scheme for Lagrangian dynamical systems

The smooth dynamics and the impact equations

Reformulations of the unilateral constraints on Different kinematics levels

Reformulations of the smooth dynamics at acceleration level.

The case of a single contact.

The multi-contact case and the index-sets

Comments and extensions

Time-stepping schemes

References

Equivalent formulations

- Inclusion into a cone $N_{\mathbb{R}^+}(\Gamma_N)$

$$-F^+ \in \begin{cases} 0 & \text{if } g > 0 \\ 0 & \text{if } g = 0, U_N^+ > 0 \\ N_{\mathbb{R}^+}(\Gamma_N) & \end{cases} \quad (6)$$

- Inclusion into $N_{T_{T_{\mathbb{R}^+}(g)}(U_N^+)}(\Gamma_n)$

$$-F^+ \in N_{T_{T_{\mathbb{R}^+}(g)}(U_N^+)}(\Gamma_n) \quad (7)$$

- In the complementarity formalism,

$$\begin{array}{ll} \text{if } g = 0, U_N^+ = 0 & 0 \leq \Gamma_N^+ \perp F^+ \geq 0 \\ \text{otherwise} & F^+ = 0 \end{array} \quad (8)$$

Reformulations of the smooth dynamics at acceleration level.

Lecture 2. Time integration of Non Smooth Dynamical Systems (NSDS).

Vincent Acary

Outline

Event-driven schemes

Event-Driven scheme for Lagrangian dynamical systems

The smooth dynamics and the impact equations

Reformulations of the unilateral constraints on Different kinematics levels

Reformulations of the smooth dynamics at acceleration level.

The case of a single contact.

The multi-contact case and the index-sets

Comments and extensions

Time-stepping schemes

References

The smooth dynamics as an inclusion

$$\left\{ \begin{array}{l} M(q(t))\gamma^+(t) + F(t, q, v^+) = f^+(t) \\ \Gamma_N = \nabla_q g(q)\gamma^+ + \nabla_q \dot{g}(q)v^+ \\ f^+(t) = \nabla_q g(q(t))^T F^+(t) \\ -F^+ \in N_{T_{\mathbb{R}^+}(g)}(U_N^+)(\Gamma_n) \end{array} \right. \quad (9)$$

Reformulations of the smooth dynamics at acceleration level.

Lecture 2. Time integration of Non Smooth Dynamical Systems (NSDS).

Vincent Acary

Outline

Event-driven schemes

Event-Driven scheme for Lagrangian dynamical systems

The smooth dynamics and the impact equations

Reformulations of the unilateral constraints on Different kinematics levels

Reformulations of the smooth dynamics at acceleration level.

The case of a single contact.

The multi-contact case and the index-sets

Comments and extensions

Time-stepping schemes

References

The smooth dynamics as a LCP

When the condition, $g = 0$, $U_N^+ = 0$ is satisfied, we obtain the following LCP

$$\begin{cases} M(q(t))\gamma^+(t) + F(t, q, v^+) = \nabla_q g(q(t))^T F^+(t) \\ \Gamma_N^+ = \nabla_q g(q)\gamma^+ + \nabla_q \dot{g}(q)v^+ \\ 0 \leq \Gamma_N^+ \perp F^+ \geq 0 \end{cases} \quad (10)$$

which can be reduced on variable Γ_N^+ and F^+ , if $M(q(t))$ is invertible,

$$\begin{cases} \Gamma_N^+ = \nabla_q g(q)M^{-1}(q(t))(-F(t, q, v^+) + \nabla_q \dot{g}(q)v^+ + \nabla_q g(q)M^{-1}\nabla_q g(q(t))^T F^+(t) \\ 0 \leq \Gamma_N^+ \perp F^+ \geq 0 \end{cases} \quad (11)$$

The case of a single contact.

Lecture 2. Time integration of Non Smooth Dynamical Systems (NSDS).

Vincent Acary

Outline

Event-driven schemes

Event-Driven scheme for Lagrangian dynamical systems

The smooth dynamics and the impact equations

Reformulations of the unilateral constraints on Different kinematics levels

Reformulations of the smooth dynamics at acceleration level.

The case of a single contact.

The multi-contact case and the index-sets

Comments and extensions

Time-stepping schemes

References

Two modes for the non smooth dynamics

- 1 *The constraint is not active.* $F^+ = 0$

$$M(q)\gamma^+ + F(\cdot, q, v) = 0 \quad (12)$$

In this case, we associate to this step an integer, $status_k = 0$.

- 2 *The constraint is active.* Bilateral constraint $\Gamma_N^+ = 0$,

$$\begin{bmatrix} M(q) & -\nabla_q g(q)^T \\ \nabla_q g(q) & 0 \end{bmatrix} \begin{bmatrix} \gamma^+ \\ F^+ \end{bmatrix} = \begin{bmatrix} -F(\cdot, q, v) \\ \nabla_q g(q)v^+ \end{bmatrix} \quad (13)$$

In this case, we associate to this step an integer, $status_k = 1$.

The case of a single contact.

Lecture 2. Time integration
of Non Smooth Dynamical
Systems (NSDS).

Vincent Acary

Outline

Event-driven schemes

Event-Driven scheme for
Lagrangian dynamical
systems

The smooth dynamics and
the impact equations

Reformulations of the
unilateral constraints on
Different kinematics levels

Reformulations of the
smooth dynamics at
acceleration level.

The case of a single contact.

The multi-contact case and
the index-sets

Comments and extensions

Time-stepping schemes

References

[Case 1] $status_k = 0$.

Integrate the system (12) on the time interval $[t_k, t_{k+1}]$

Case 1.1 $g_{k+1} > 0$

The constraint is still not active. We set $status_{k+1} = 0$.

Case 1.2 $g_{k+1} = 0, U_{N,k+1} < 0$

In this case an impact occurs. The value $U_{N,k+1} < 0$ is considered as the pre-impact velocity U^- and the impact equation (3) is solved. After, we set $U_{N,k+1} = U^+$. Two cases are then possible:

Case 1.2.1 $U_+ > 0$

Just after the impact, the relative velocity is positive. The constraint ceases to be active and we set $status_{k+1} = 0$.

Case 1.2.2 $U_+ = 0$

The relative post-impact velocity vanishes. In the case, in order to determine the new status, we solve the LCP (10) to obtain. three cases are then possible:

Case 1.2.2.1 $\Gamma_{N,k+1} > 0, F_{k+1} = 0$

The constraint is still not active. We set $status_{k+1} = 0$.

Case 1.2.2.2 $\Gamma_{N,k+1} = 0, F_{k+1} > 0$

The constraint has to be activated. We set $status_{k+1} = 1$.

Case 1.2.2.3 $\Gamma_{N,k+1} = 0, F_{k+1} = 0$

This case is undetermined. We need to know the value of $\dot{\Gamma}_N^+$.

The case of a single contact.

Lecture 2. Time integration
of Non Smooth Dynamical
Systems (NSDS).

Vincent Acary

Outline

Event-driven schemes

Event-Driven scheme for
Lagrangian dynamical
systems

The smooth dynamics and
the impact equations

Reformulations of the
unilateral constraints on
Different kinematics levels

Reformulations of the
smooth dynamics at
acceleration level.

The case of a single contact.

The multi-contact case and
the index-sets

Comments and extensions

Time-stepping schemes

References

[Case 1] $status_k = 0$.

Integrate the system (12) on the time interval $[t_k, t_{k+1}]$

Case 1.3 $g_{k+1} = 0, U_{N,k+1} = 0$

In this case, we have a grazing constraint. To know what should be the status for the future time, we compute the value of $\Gamma_{N,k+1}, F_{k+1}$ thanks to the LCP (10) assuming that $U^+ = U^- = U_{N,k+1}$. Three cases are then possible:

Case 1.3.1 $\Gamma_{N,k+1} > 0, F_{k+1} = 0$

The constraint is still not active. We set $status_{k+1} = 0$.

Case 1.3.2 $\Gamma_{N,k+1} = 0, F_{k+1} > 0$

The constraint has to be activated. We set $status_{k+1} = 1$.

Case 1.3.3 $\Gamma_{N,k+1} = 0, F_{k+1} = 0$

This case is undetermined. We need to know the value of $\dot{\Gamma}_N^+$.

Case 1.4 $g_{k+1} = 0, U_{N,k+1} < 0$

The activation of the constraint has not been detected. We seek for the first time t_* such that $g = 0$. We set $t_{k+1} = t_*$. Then we perform all of these procedure keeping $status_k = 0$.

Case 1.5 $g_{k+1} < 0$

The activation of the constraint has not been detected. We seek for the first time t_* such that $g = 0$. We set $t_{k+1} = t_*$. Then we perform all of these procedure keeping $status_k = 0$.

The case of a single contact.

Lecture 2. Time integration of Non Smooth Dynamical Systems (NSDS).

Vincent Acary

Outline

Event-driven schemes

Event-Driven scheme for Lagrangian dynamical systems

The smooth dynamics and the impact equations

Reformulations of the unilateral constraints on Different kinematics levels

Reformulations of the smooth dynamics at acceleration level.

The case of a single contact.

The multi-contact case and the index-sets

Comments and extensions

Time-stepping schemes

References

[Case 2] $status_k = 1$

Integrate the system (13) on the time interval $[t_k, t_{k+1}]$

Case 2.1 $g_{k+1} \neq 0$ or $U_{N,k+1} = 0$

Something is wrong in the time integration or the drift from the constraints is too huge.

Case 2.2 $g_{k+1} = 0, U_{N,k+1} = 0$

In this case, we assume that $U^+ = U^- = U_{N,k+1}$ and we compute $\Gamma_{N,k+1}, F_{k+1}$ thanks to the LCP (10) assuming that $U^+ = U^- = U_{N,k+1}$. Three cases are then possible

Case 2.2.1 $\Gamma_{N,k+1} = 0, F_{k+1} > 0$

The constraint is still active. We set $status_{k+1} = 1$.

Case 2.2.2 $\Gamma_{N,k+1} > 0, F_{k+1} = 0$

The bilateral constraint is no longer valid. We seek for the time t_* such that $F^+ = 0$. We set $t_{k+1} = t_*$ and we perform the integration up to this instant. We perform all of these procedure at this new time t_{k+1}

Case 2.2.3 $\Gamma_{N,k+1} = 0, F_{k+1} = 0$

This case is undetermined. We need to know the value of $\dot{\Gamma}_N^+$.

The case of a single contact.

Lecture 2. Time integration of Non Smooth Dynamical Systems (NSDS).

Vincent Acary

Outline

Event-driven schemes

Event-Driven scheme for Lagrangian dynamical systems

The smooth dynamics and the impact equations

Reformulations of the unilateral constraints on Different kinematics levels

Reformulations of the smooth dynamics at acceleration level.

The case of a single contact.

The multi-contact case and the index-sets

Comments and extensions

Time-stepping schemes

References

Comments

- The Delassus example.
In the one-contact case, a naive approach consists in to suppressing the constraint $F_{k+1} = 0 < 0$ after a integration with a bilateral constraints.
→ Work only for the one contact case.
- The role of the “ ε ”
In practical situation, all of the test are made up to an accuracy threshold. All statements of the type $g = 0$ are replaced by $|g| < \varepsilon$. The role of these epsilons can be very important and they are quite difficult to size.

The case of a single contact.

Lecture 2. Time integration
of Non Smooth Dynamical
Systems (NSDS).

Vincent Acary

Outline

Event-driven schemes

Event-Driven scheme for
Lagrangian dynamical
systems

The smooth dynamics and
the impact equations

Reformulations of the
unilateral constraints on
Different kinematics levels

Reformulations of the
smooth dynamics at
acceleration level.

The case of a single contact.

The multi-contact case and
the index-sets

Comments and extensions

Time-stepping schemes

References

Comments

- If the ODE solvers is able to perform the root finding of the function $g = 0$ for $status_k = 0$ and $F^+ = 0$ for $status_k = 1$
→ the case 1.4, 1.5 and the case 2.2.2 can be suppressed in the decision tree.
 - If the drift from the constraints is also controlled into the ODE solver by a error computation,
→ the case 2.1 can also be suppressed
 - Most of the case can be resumed into the following step
 - Continue with the same status
 - Compute $U_{N,k+1}, P_{k+1}$ thanks to the LCP (3)(impact equations).
 - Compute $\Gamma_{N,k+1}, F_{k+1}$ thanks to the LCP (10) (Smooth dynamics)
- Rearranging the cases, we obtain the following algorithm.

The case of a single contact. An algorithm

Lecture 2. Time integration
of Non Smooth Dynamical
Systems (NSDS).

Vincent Acary

Outline

Event-driven schemes

Event-Driven scheme for
Lagrangian dynamical
systems

The smooth dynamics and
the impact equations

Reformulations of the
unilateral constraints on
Different kinematics levels

Reformulations of the
smooth dynamics at
acceleration level.

The case of a single contact.

The multi-contact case and
the index-sets

Comments and extensions

Time-stepping schemes

References

Require: $(g_k, U_{N,k}, status_k)$

Ensure: $(g_{k+1}, U_{N,k+1}, status_{k+1})$

Time-integration of the system on $[t_k, t_{k+1}]$ (12) if $status_k = 0$ or of the system (13) if $status_k = 1$ up to an event.

if $g_{k+1} > 0$ **then**

$status_{k+1} = 0$ //The constraint is still not active. (case 1.1)

end if

if $g_{k+1} = 0, U_{N,k+1} < 0$ **then**

//The constraint is active $g_{k+1} = 0$ and an impact occur $U_{N,k+1} < 0$ (case 1.2)

Solve the LCP (3) for $U_N^- = U_{N,k+1}$; $U_{N,k+1} = U_N^+$

if $U_{N,k+1} > 0$ **then** $status_{k+1} = 0$

end if

if $g_{k+1} = 0, U_{N,k+1} = 0$ **then**

//The constraint is active $g_{k+1} = 0$ without impact (case 1.2.2, case 1.3, case 2.2)

solve the LCP (11)

if $\Gamma_{N,k+1} = 0, F_{k+1} > 0$ **then**

$status_{k+1} = 1$

else if $\Gamma_{N,k+1} > 0, F_{k+1} = 0$ **then**

$status_{k+1} = 0$

else if $\Gamma_{N,k+1} = 0, F_{k+1} = 0$ **then**

//Undetermined case.

end if

end if

Go to the next time step

The multi-contact case and the index-sets

Lecture 2. Time integration
of Non Smooth Dynamical
Systems (NSDS).

Vincent Acary

Outline

Event-driven schemes

Event-Driven scheme for
Lagrangian dynamical
systems

The smooth dynamics and
the impact equations

Reformulations of the
unilateral constraints on
Different kinematics levels

Reformulations of the
smooth dynamics at
acceleration level.

The case of a single contact.

**The multi-contact case and
the index-sets**

Comments and extensions

Time-stepping schemes

References

Index sets

The index set I is the set of all unilateral constraints in the system

$$I = \{1 \dots \nu\} \subset \mathbb{N} \quad (14)$$

The index-set I_c is the set of all active constraints of the system,

$$I_c = \{\alpha \in I, g^\alpha = 0\} \subset I \quad (15)$$

and the index-set I_s is the set of all active constraints of the system with a relative velocity equal to zero,

$$I_s = \{\alpha \in I_c, U_N^\alpha = 0\} \subset I_c \quad (16)$$

Impact equations

$$\left\{ \begin{array}{l} M(q(t_i))(v^+(t_i) - v^-(t_i)) = p_i, \\ U_N^+(t_i) = \nabla_q g(q(t_i))v^+(t_i) \\ U_N^-(t_i) = \nabla_q g(q(t_i))v^-(t_i) \\ p_i = \nabla_q^T g(q(t_i))P_{N,i} \\ \\ P_{N,i}^\alpha = 0; U_N^{\alpha,+}(t_i) = U_N^{\alpha,-}(t_i), \quad \forall \alpha \in I \setminus I_c \\ \\ 0 \leq U_N^{+,\alpha}(t_i) + e U_N^{-,\alpha}(t_i) \perp P_{N,i}^\alpha \geq 0, \quad \forall \alpha \in I_c \end{array} \right. \quad (17)$$

Using the fact that $P_{N,i}^\alpha = 0$ for $\alpha \in I \setminus I_c$, this problem can be reduced on the local unknowns $U_N^+(t_i), P_{N,i} \quad \forall \alpha \in I_c$.

Modes for the smooth Dynamics

■ The smooth unilateral dynamics as a LCP

$$\begin{cases} M(q)\gamma^+ + F_{int}(\cdot, q, v) = F_{ext} + \nabla_q g(q)^T F^+ \\ \Gamma_N^+ = \nabla_q g(q)\gamma^+ + \nabla_q \dot{g}(q)v^+ \\ F^{+, \alpha} = 0, \quad \forall \alpha \in I \setminus I_s \\ 0 \leq \Gamma_N^{+, \alpha} \perp F^{+, \alpha} \geq 0 \quad \forall \alpha \in I_s \end{cases} \quad (18)$$

■ The smooth bilateral dynamics

$$\begin{cases} M(q)\gamma^+ + F_{int}(\cdot, q, v) = F_{ext} + \nabla_q g(q)^T F^+ \\ \Gamma_N^+ = \nabla_q g(q)\gamma^+ + \nabla_q \dot{g}(q)v^+ \\ F^{+, \alpha} = 0, \quad \forall \alpha \in I \setminus I_s \\ \Gamma_N^{+, \alpha} = 0 \quad \forall \alpha \in I_s \end{cases} \quad (19)$$

The multi-contact case and the index-sets. an algorithm

Lecture 2. Time integration
of Non Smooth Dynamical
Systems (NSDS).

Vincent Acary

Outline

Event-driven schemes

Event-Driven scheme for
Lagrangian dynamical
systems

The smooth dynamics and
the impact equations

Reformulations of the
unilateral constraints on
Different kinematics levels

Reformulations of the
smooth dynamics at
acceleration level.

The case of a single contact.

**The multi-contact case and
the index-sets**

Comments and extensions

Time-stepping schemes

References

Require: $(g_k, U_{N,k}, I_{c,k}, I_{s,k})$,

Ensure: $(g_{k+1}, U_{N,k+1}, I_{c,k+1}, I_{s,k+1})$

Time-integration on $[t_k, t_{k+1}]$ of the system (19) according to $I_{c,k}$ and $I_{s,k}$ up to an event.

Compute the temporary index-sets $I_{c,k+1}$ and $I_{s,k+1}$.

if $I_{c,k+1} \setminus I_{s,k+1} \neq \emptyset$ **then**

//Impacts occur.

Solve the LCP (17).

Update the index-set $I_{c,k+1}$ and temporary $I_{s,k+1}$

Check that $I_{c,k+1} \setminus I_{s,k+1} = \emptyset$

end if

if $I_{s,k+1} \neq \emptyset$ **then**

Solve the LCP (18)

for $\alpha \in I_{s,k+1}$ **do**

if $\Gamma_{N,\alpha,k+1} > 0, F_{\alpha,k+1} = 0$ **then**

remove α from $I_{s,k+1}$ and $I_{c,k+1}$

else if $\Gamma_{N,\alpha,k+1} = 0, F_{\alpha,k+1} = 0$ **then**

//Undetermined case.

end if

end for

end if

// Go to the next time step

The multi-contact case and the index-sets

Lecture 2. Time integration of Non Smooth Dynamical Systems (NSDS).

Vincent Acary

Outline

Event-driven schemes

Event-Driven scheme for Lagrangian dynamical systems

The smooth dynamics and the impact equations

Reformulations of the unilateral constraints on Different kinematics levels

Reformulations of the smooth dynamics at acceleration level.

The case of a single contact.

The multi-contact case and the index-sets

Comments and extensions

Time-stepping schemes

References

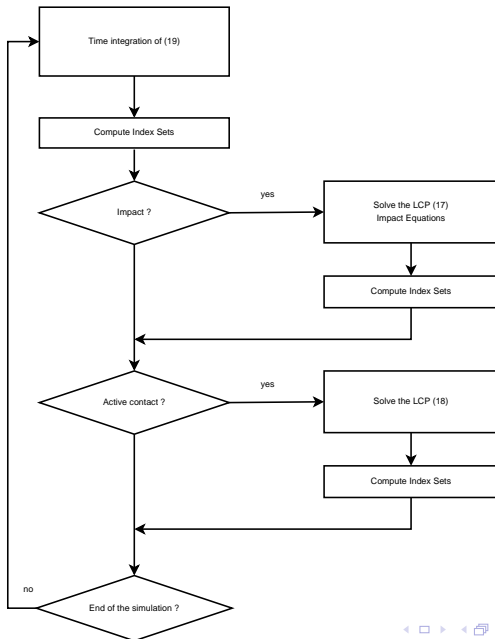

Extensions to Coulomb's friction

The set I_r is the set of sticking or rolling contact:

$$I_r = \{\alpha \in I_s, U_N^\alpha = 0, \|U_T\| = 0\} \subset I_s, \quad (20)$$

is the set of sticking or rolling contact, and

$$I_t = \{\alpha \in I_s, U_N^\alpha = 0, \|U_T\| > 0\} \subset I_s, \quad (21)$$

is the set of slipping or sliding contact.

Remarks

In the 3D case, checking the events and the transition sticking/sliding and sliding/sticking is not a easy task.

Advantages and Weaknesses and the Event Driven schemes

■ Advantages :

- Low cost implementation of time integration solvers (re-use of existing ODE solvers).
- Higher-order accuracy on free motion.
- Pseudo-localization of the time of events with finite time-step.

■ Weaknesses

- Numerous events in short time.
- Accumulation of impacts.
- No convergence proof
- Robustness with the respect to thresholds " ϵ ". Tuning codes is difficult.

Principle of Time-stepping schemes

Lecture 2. Time integration of Non Smooth Dynamical Systems (NSDS).

Vincent Acary

Outline

Event-driven schemes

Event-Driven scheme for Lagrangian dynamical systems

Time-stepping schemes

Principle

The Moreau's catching-up algorithm for the first order sweeping process

Time stepping scheme for Linear Complementarity Systems (LCS)

Time stepping scheme for Differential Variational Inequalities (DVI)

References

- 1 A unique formulation of the dynamics is considered. For instance, for the Lagrangian systems, a dynamics in terms of measures.

$$\begin{cases} M(q)dv + F(t, q, v^+)dt = dr \\ v^+ = \dot{q}^+ \end{cases} \quad (22)$$

- 2 The time-integration is based on a consistent approximation of the equations in terms of measures. For instance,

$$\int_{]t_k, t_{k+1}] } dv = \int_{]t_k, t_{k+1}] } dv = (v^+(t_{k+1}) - v^+(t_k)) \approx (v_{k+1} - v_k) \quad (23)$$

- 3 Consistent approximation of measure inclusion.

$$-dr \in N_{T_C(q(t))}(v^+(t)) \quad (24) \quad \rightarrow \quad \begin{cases} p_{k+1} \approx \int_{]t_k, t_{k+1}] } dr \\ p_{k+1} \in N_{T_C(q_k)}(v_{k+1}) \end{cases} \quad (25)$$

The Moreau's catching-up algorithm for the first order sweeping process

Lecture 2. Time integration of Non Smooth Dynamical Systems (NSDS).

Vincent Acary

Outline

Event-driven schemes

Event-Driven scheme for Lagrangian dynamical systems

Time-stepping schemes

Principle

The Moreau's catching-up algorithm for the first order sweeping process

Time stepping scheme for Linear Complementarity Systems (LCS)

Time stepping scheme for Differential Variational Inequalities (DVI)

References

Catching-up algorithm

Let us consider the first order sweeping process with a B.V. solution:

$$\begin{cases} -du \in N_{K(t)}(u(t)) \quad (t \geq 0), \\ u(0) = u_0. \end{cases} \quad (26)$$

The so-called "Catching-up algorithm" is defined in MOREAU (1977):

$$-(u_{k+1} - u_k) \in \partial\psi_{K(t_{k+1})}(u_{k+1}) \quad (27)$$

where u_k stands for the approximation of the right limit of u at t_k .

By elementary convex analysis, this is equivalent to:

$$u_{k+1} = \text{prox}(K(t_{k+1}), u_k). \quad (28)$$

The Moreau's catching-up algorithm for the first order sweeping process

Lecture 2. Time integration of Non Smooth Dynamical Systems (NSDS).

Vincent Acary

Outline

Event-driven schemes

Event-Driven scheme for Lagrangian dynamical systems

Time-stepping schemes

Principle

The Moreau's catching-up algorithm for the first order sweeping process

Time stepping scheme for Linear Complementarity Systems (LCS)

Time stepping scheme for Differential Variational Inequalities (DVI)

References

Difference with an backward Euler scheme

- the catching-up algorithm is based on the evaluation of the measure du on the interval $]t_k, t_{k+1}]$, i.e. $du(]t_k, t_{k+1}]) = u^+(t_{k+1}) - u^+(t_k)$.
- the backward Euler scheme is based on the approximation of $\dot{u}(t)$ which is not defined in a classical sense for our case.

When the time step vanishes, the approximation of the measure du tends to a finite value corresponding to the jump of u . Particularly, this fact ensures that we handle only finite values.

Higher order approximation

Higher order schemes are meant to approximate the n -th derivative of the discretized function. Non sense for a non smooth solution.

Mathematical results

For Lipschitz and RCBV sweeping processes, convergence and consistency results are based on the catching-up algorithm.

MONTEIRO MARQUES (1993) ; KUNZE & MONTEIRO MARQUES (2000)

The Moreau's catching-up algorithm for the first order sweeping process

Lecture 2. Time integration of Non Smooth Dynamical Systems (NSDS).

Vincent Acary

Outline

Event-driven schemes

Event-Driven scheme for Lagrangian dynamical systems

Time-stepping schemes

Principle

The Moreau's catching-up algorithm for the first order sweeping process

Time stepping scheme for Linear Complementarity Systems (LCS)

Time stepping scheme for Differential Variational Inequalities (DVI)

References

Time-independent convex set K

Let us recall now the UDI

$$-(\dot{x}(t) + f(x(t)) + g(t)) \in \mathbf{N}_K(x(t)), \quad x(0) = x_0 \quad (29)$$

In the same way, the inclusion can be discretized by

$$-(x_{k+1} - x_k) + h(f(x_{k+1}) + g(t_{k+1})) = \mu_{k+1} \in \mathbf{N}_K(x_{k+1}), \quad (30)$$

- In this discretization, an evaluation of the measure dx by the approximates value μ_{k+1} .
- If the initial condition does not satisfy the inclusion at the initial time, the jump in the state can be treated in a consistent way.

The Moreau's catching-up algorithm for the first order sweeping process

Lecture 2. Time integration of Non Smooth Dynamical Systems (NSDS).

Vincent Acary

Outline

Event-driven schemes

Event-Driven scheme for Lagrangian dynamical systems

Time-stepping schemes

Principle

The Moreau's catching-up algorithm for the first order sweeping process

Time stepping scheme for Linear Complementarity Systems (LCS)

Time stepping scheme for Differential Variational Inequalities (DVI)

References

Time-independent convex set $K = \mathbb{R}_+^n$

The previous problem can be written as a special non linear complementarity problem:

$$\begin{cases} (x_{k+1} - x_k) - h(f(x_{k+1}) + g(t_{k+1})) = \mu_{k+1} \\ 0 \leq x_{k+1} \perp \mu_{k+1} \geq 0 \end{cases} \quad (31)$$

If $f(x) = Ax$ we obtain the following LCP(q,M):

$$\begin{cases} (I - hA)x_{k+1} - (x_k + hg(t_{k+1})) = \mu_{k+1} \\ 0 \leq x_{k+1} \perp \mu_{k+1} \geq 0 \end{cases} \quad (32)$$

with $M = (I - hA)$ and $q = -(x_k + hg(t_{k+1}))$.

Remark

It is noteworthy that the value μ_{k+1} approximates the measure $d\lambda$ on the time interval rather than directly the value of λ .

The Moreau's catching-up algorithm for the first order sweeping process

Lecture 2. Time integration of Non Smooth Dynamical Systems (NSDS).

Vincent Acary

Outline

Event-driven schemes

Event-Driven scheme for Lagrangian dynamical systems

Time-stepping schemes

Principle

The Moreau's catching-up algorithm for the first order sweeping process

Time stepping scheme for Linear Complementarity Systems (LCS)

Time stepping scheme for Differential Variational Inequalities (DVI)

References

Remark

Particularly, if the set K is polyhedral by :

$$K = \{x, Cx \geq 0\} \quad (33)$$

If a constraint qualification holds, the DI (29) in the linear case $f(x) = -Ax$ is equivalent to the following LCS:

$$\begin{cases} \dot{x} = Ax + C^T \lambda \\ y = Cx \\ 0 \leq y \perp \lambda \geq 0 \end{cases} \quad (34)$$

In this case, the catching-up algorithm yields:

$$\begin{cases} x_{k+1} - x_k = hAx_{k+1} + C^T \mu^{k+1} \\ y_{k+1} = Cx_{k+1} \\ 0 \leq y_{k+1} \perp \mu_{k+1} \geq 0 \end{cases} \quad (35)$$

We will see later in Section 3 that this discretization is very similar to the discretization proposed by CAMLIBEL *et al.* (2002) for LCS.

Time stepping scheme for Linear Complementarity Systems (LCS)

Lecture 2. Time integration of Non Smooth Dynamical Systems (NSDS).

Vincent Acary

Outline

Event-driven schemes

Event-Driven scheme for Lagrangian dynamical systems

Time-stepping schemes

Principle

The Moreau's catching-up algorithm for the first order sweeping process

Time stepping scheme for Linear Complementarity Systems (LCS)

Time stepping scheme for Differential Variational Inequalities (DVI)

References

Backward Euler scheme

Starting from the LCS

$$\begin{cases} \dot{x} = Ax + B\lambda \\ y = Cx + D\lambda \\ 0 \leq y \perp \lambda \geq 0 \end{cases} \quad (36)$$

CAMLIBEL *et al.* (2002) apply a backward Euler scheme to evaluate the time derivative \dot{x} leading to the following scheme:

$$\begin{cases} \frac{x_{k+1} - x_k}{h} = Ax_{k+1} + B\lambda_{k+1} \\ y_{k+1} = Cx_{k+1} + D\lambda_{k+1} \\ 0 \leq \lambda_{k+1} \perp y_{k+1} \geq 0 \end{cases} \quad (37)$$

which can be reduced to a LCP by a straightforward substitution:

$$0 \leq \lambda_{k+1} \perp C(I - hA)^{-1}x_k + (hC(I - hA)^{-1}B + D)\lambda_{k+1} \geq 0 \quad (38)$$

Time stepping scheme for Linear Complementarity Systems (LCS)

Lecture 2. Time integration of Non Smooth Dynamical Systems (NSDS).

Vincent Acary

Outline

Event-driven schemes

Event-Driven scheme for Lagrangian dynamical systems

Time-stepping schemes

Principle

The Moreau's catching-up algorithm for the first order sweeping process

Time stepping scheme for Linear Complementarity Systems (LCS)

Time stepping scheme for Differential Variational Inequalities (DVI)

References

Convergence results

If D is nonnegative definite or that the triplet (A, B, C) is observable and controllable and (A, B, C, D) is positive real, they exhibit that some subsequences of $\{y_k\}$, $\{\lambda_k\}$, $\{x_k\}$ converge weakly to a solution y, λ, x of the LCS. CAMLIBEL *et al.* (2002)

Such assumptions imply that the relative degree r is less or equal to 1.

Remarks

- In the case of the relative degree 0, the LCS is equivalent to a standard system of ODE with a Lipschitz-continuous r.h.s field. The result of convergence is then similar to the standard result of convergence for the Euler backward scheme.
- In the case of a relative degree equal to 1, the initial condition must satisfy the unilateral constraints $y_0 = Cx_0 \geq 0$. Otherwise, the approximation $\frac{x_{k+1} - x_k}{h}$ has non chance to converge if the state possesses a jump. This situation is precluded in the result of convergence in (CAMLIBEL *et al.*, 2002).

Time stepping scheme for Linear Complementarity Systems (LCS)

Lecture 2. Time integration of Non Smooth Dynamical Systems (NSDS).

Vincent Acary

Outline

Event-driven schemes

Event-Driven scheme for Lagrangian dynamical systems

Time-stepping schemes

Principle

The Moreau's catching-up algorithm for the first order sweeping process

Time stepping scheme for Linear Complementarity Systems (LCS)

Time stepping scheme for Differential Variational Inequalities (DVI)

References

Remark

Following the remark 5, we can note some similarities with the catching-up algorithm. Two main differences have however to be noted:

- the first one is that the sweeping process can be equivalent to a LCS under the condition $C = B^T$. In this way, the previous time-stepping scheme extend the catching-up algorithm to more general systems.
- The second major discrepancy is as follows. The catching-up algorithm does not approximate directly the time-derivative \dot{x} as

$$\dot{x}(t) \approx \frac{x(t+h) - x(t)}{h} \quad (39)$$

but directly the measure of the time interval by

$$dx([t, t+h]) = x^+(t+h) - x^+(t) \quad (40)$$

This difference leads to a consistent time-stepping scheme if the state possesses an initial jump. A direct consequence is that the primary variable μ_{k+1} in the catching up algorithm is homogeneous to a measure of the time-interval.

Time stepping scheme for Linear Complementarity Systems (LCS)

Lecture 2. Time integration of Non Smooth Dynamical Systems (NSDS).

Vincent Acary

Outline

Event-driven schemes

Event-Driven scheme for Lagrangian dynamical systems

Time-stepping schemes

Principle

The Moreau's catching-up algorithm for the first order sweeping process

Time stepping scheme for Linear Complementarity Systems (LCS)

Time stepping scheme for Differential Variational Inequalities (DVI)

References

θ -method

In the case of a relative degree 0, the following scheme based on a θ -method ($\theta \in [0, 1]$) should work also

$$\left\{ \begin{array}{l} \frac{x_{k+1} - x_k}{h} = A(\theta x_{k+1} + (1 - \theta)x_k) + B(\theta \lambda_{k+1} + (1 - \theta)\lambda_k) \\ y_{k+1} = Cx_{k+1} + D\lambda_{k+1} \\ 0 \leq \lambda_{k+1} \perp w_{k+1} \geq 0 \end{array} \right. \quad (41)$$

because a C^1 trajectory is expected.

- We have successfully tested it on electrical circuit of degree 0 in the semi-implicit case $\theta \in [1/2, 1]$.
- An interesting feature of such θ -method is the energy conserving property that they exhibit for $\theta = 1/2$. We will see in the following section that the scheme can be viewed as a special case of the time-stepping scheme proposed by PANG (2006).

Time stepping scheme for Differential Variational Inequalities (DVI)

Lecture 2. Time integration of Non Smooth Dynamical Systems (NSDS).

Vincent Acary

Outline

Event-driven schemes

Event-Driven scheme for Lagrangian dynamical systems

Time-stepping schemes

Principle

The Moreau's catching-up algorithm for the first order sweeping process

Time stepping scheme for Linear Complementarity Systems (LCS)

Time stepping scheme for Differential Variational Inequalities (DVI)

References

In (PANG, 2006), several time-stepping schemes are designed for DVI which are separable in u ,

$$\dot{x}(t) = f(t, x(t)) + B(x(t), t)u(t) \quad (42)$$

$$u(t) = \text{SOL}(K, G(t, x(t)) + F(\cdot)) \quad (43)$$

We recall that the second equation means that $u(t) \in K$ is the solution of the following VI

$$(v - u)^T \cdot (G(t, x(t)) + F(u(t))) \geq 0, \forall v \in K \quad (44)$$

Two cases are treated with a time-stepping scheme: the Initial Value Problem (IVP) and the Boundary Value Problem (BVP).

Time stepping scheme for DVI. IVP case.

Lecture 2. Time integration of Non Smooth Dynamical Systems (NSDS).

Vincent Acary

Outline

Event-driven schemes

Event-Driven scheme for Lagrangian dynamical systems

Time-stepping schemes

Principle

The Moreau's catching-up algorithm for the first order sweeping process

Time stepping scheme for Linear Complementarity Systems (LCS)

Time stepping scheme for Differential Variational Inequalities (DVI)

References

IVP case.

$$\dot{x}(t) = f(t, x(t)) + B(x(t), t)u(t) \quad (45)$$

$$u(t) = \text{SOL}(K, G(t, x(t)) + F(\cdot)) \quad (46)$$

$$x(0) = x_0 \quad (47)$$

The proposed time-stepping method is given as follows

$$x_{k+1} - x_k = h[f(t_k, \theta x_{k+1} + (1 - \theta)x_k) + B(x_k, t_k)u_{k+1}] \quad (48)$$

$$u_{k+1} = \text{SOL}(K, G(t_{k+1}, x_{k+1}) + F(\cdot)) \quad (49)$$

Time stepping scheme for DVI. IVP case.

Lecture 2. Time integration of Non Smooth Dynamical Systems (NSDS).

Vincent Acary

Outline

Event-driven schemes

Event-Driven scheme for Lagrangian dynamical systems

Time-stepping schemes

Principle

The Moreau's catching-up algorithm for the first order sweeping process

Time stepping scheme for Linear Complementarity Systems (LCS)

Time stepping scheme for Differential Variational Inequalities (DVI)

References

Explicit scheme $\theta = 0$

An explicit discretization of \dot{x} is realized leading to the one-step non smooth problem

$$x_{k+1} = x_k + h[f(t_k, x_k) + B(x_k, t_k)u_{k+1}] \quad (50)$$

where u_{k+1} solves the VI(K, F_{k+1}) with

$$F_{k+1}(u) = G(t_{k+1}, h[f(t_k, x_k) + B(x_k, t_k)u]) + F(u) \quad (51)$$

Remark

- In the last VI, the value u_{k+1} can be evaluated in explicit way with respect to x_{k+1} .
- It is noteworthy that even in the explicit case, the VI is always solved in a implicit ways, i.e. for x_{k+1} and u_{k+1} .

Semi-implicit scheme

If $\theta \in]0, 1]$, the pair u_{k+1}, x_{k+1} solves the VI($\mathbb{R}^n \times K, F_{k+1}$) with

$$F_{k+1}(x, u) = \left[\begin{array}{c} x - x_k - h[f(t_k, \theta x + (1 - \theta)x_k) + B(x_k, t_k)u] \\ G(t_{k+1}, x) + F(u) \end{array} \right] \quad (52)$$

Time stepping scheme for DVI. IVP case.

Lecture 2. Time integration of Non Smooth Dynamical Systems (NSDS).

Vincent Acary

Outline

Event-driven schemes

Event-Driven scheme for Lagrangian dynamical systems

Time-stepping schemes

Principle

The Moreau's catching-up algorithm for the first order sweeping process

Time stepping scheme for Linear Complementarity Systems (LCS)

Time stepping scheme for Differential Variational Inequalities (DVI)

References

Convergence results

In (PANG, 2006), the convergence of the semi-implicit case is proved. For that, a continuous piecewise linear function, x^h is built by interpolation of the approximate values x_k ,

$$x^h(t) = x_k + \frac{t - t_k}{h}(x_{k+1} - x_k), \forall t \in [t_k, t_k + 1] \quad (53)$$

and a piecewise constant function u^h is build such that

$$u^h(t) = u_{k+1}, \forall t \in]t_k, t_k + 1] \quad (54)$$

It is noteworthy that the approximation x^h is constructed as a continuous function rather than u^h may be discontinuous.

Convergence results

The existence of a subsequence of u_h, x_h denoted by u^{h_ν}, x^{h_ν} such that

- x^{h_ν} converges uniformly to \hat{x} on $[0, T]$
- u^{h_ν} converges weakly to \hat{u} in $\mathcal{L}^2(0, T)$

under the following assumptions:

- 1 f and G are Lipschitz continuous on $\Omega = [0, T] \times \mathbb{R}^n$,
- 2 B is a continuous bounded matrix-valued function on Ω ,
- 3 K is closed and convex (not necessarily bounded)
- 4 F is continuous
- 5 $\text{SOL}(K, q + F) \neq \emptyset$ and convex such that $\forall q \in G(\Omega)$, the following growth condition holds

$$\exists \rho > 0, \sup\{\|u\|, u \in \text{SOL}(K, q + F)\} \leq \rho(1 + \|q\|) \quad (53)$$

This assumption is used to prove that a pair u_{k+1}, x_{k+1} exists for the VI (52). This assumption of the type “growth condition” is quite usual to prove existence of solution of VI through fixed-point theorem (see (FACCHINEI & PANG, 2003)).

Convergence results

Furthermore, under either one of the following two conditions:

- $F(u) = Du$ (i.e. linear VI) for some positive semidefinite matrix, D
- $F(u) = \Psi(Eu)$, where Ψ is Lipschitz continuous and $\exists c > 0$ such that

$$\|Eu_{k+1} - E_k\| \leq ch \quad (53)$$

all limits (\hat{x}, \hat{u}) are weak solutions of the initial-value DVI.

→ This proof convergence provide us with an existence result for such DVI with a separable in u .

The linear growth condition which is strong assumption in most of practical case can be dropped. In this case, some monotonicity assumption has to be made on F and strong monotonicity assumption on the map $u \mapsto G(t, x) \circ (r + B(t, x)u)$ for all $t \in [0, T], x \in \mathbb{R}^n, r \in \mathbb{R}^n$. We refer to (PANG, 2006) for more details. If $G(x, t) = Cx$, the last assumption means that CB is positive definite.

Time stepping scheme for DVI. BVP case

Lecture 2. Time integration of Non Smooth Dynamical Systems (NSDS).

Vincent Acary

Outline

Event-driven schemes

Event-Driven scheme for Lagrangian dynamical systems

Time-stepping schemes

Principle

The Moreau's catching-up algorithm for the first order sweeping process

Time stepping scheme for Linear Complementarity Systems (LCS)

Time stepping scheme for Differential Variational Inequalities (DVI)

References

BVP case

Let us consider now the Boundary value problem with linear boundary function

$$\dot{x}(t) = f(t, x(t)) + B(x(t), t)u(t) \quad (54)$$

$$u(t) = \text{SOL}(K, G(t, x(t)) + F(\cdot)) \quad (55)$$

$$b = Mx(0) + Nx(T) \quad (56)$$

The time-stepping proposed by PANG (2006) is as follows :

$$x_{k+1} - x_k = h[f(t_k, \theta x_{k+1} + (1 - \theta)x_k) + B(x_k, t_k)u_{k+1}], \quad k \in \{0, \dots, N\}$$

$$u_{k+1} = \text{SOL}(K, G(t_{k+1}, x_{k+1}) + F(\cdot)), \quad k \in \{0, \dots, N - 1\}$$

plus the boundary condition

$$b = Mx_0 + Nx_N \quad (60)$$

Comments

The system is henceforth a coupled and large VI for which the numerical solution is not trivial.

Convergence results

The existence of the discrete time-trajectory is ensured under the following assumption :

- 1 F monotone and VI solutions have linear growth
- 2 the map $u \mapsto G(t, x) \circ (r + B(t, x)u)$ is strongly monotone
- 3 $M + N$ is non singular and satisfies

$$\exp(T\psi_x) < 1 + \frac{1}{\|(M + N)^{-1}N\|}$$

where $\psi_x \geq 0$ is a constant derived from problem data.

The convergence of the discrete time trajectory is proved if F is linear.

Time stepping scheme for Differential Variational Inequalities (DVI)

Lecture 2. Time integration of Non Smooth Dynamical Systems (NSDS).

Vincent Acary

Outline

Event-driven schemes

Event-Driven scheme for Lagrangian dynamical systems

Time-stepping schemes

Principle

The Moreau's catching-up algorithm for the first order sweeping process

Time stepping scheme for Linear Complementarity Systems (LCS)

Time stepping scheme for Differential Variational Inequalities (DVI)

References

General remarks

- The time-stepping scheme can be viewed as extension of the DCS, the UDI and the Moreau's catching up algorithm.
- But, the scheme is more a mathematical discretization rather a numerical method. In practice, the numerical solution of a VI is difficult to obtain when the set K is unstructured.
- The case K is polyhedral is equivalent to a DCS.

Lecture 2. Time integration of Non Smooth Dynamical Systems (NSDS).

Vincent Acary

Outline

Event-driven schemes

Event-Driven scheme for Lagrangian dynamical systems

Time-stepping schemes

Principle

The Moreau's catching-up algorithm for the first order sweeping process

Time stepping scheme for Linear Complementarity Systems (LCS)

Time stepping scheme for Differential Variational Inequalities (DVI)

References

Thank you for your attention.

- K. CAMLIBEL, W.P.M.H. HEEMELS & J.M. SCHUMACHER. Consistency of a time-stepping method for a class of piecewise-linear networks. *IEEE Transactions on Circuits and Systems I*, 49, pp. 349–357, 2002.
- A.L. DONTCHEV & E.M. FARKHI. Error estimates for discretized differential inclusions. *Computing*, 41(4), pp. 349–358, 1989.
- A.L. DONTCHEV & F. LEMPIO. Difference methods for differential inclusions: a survey. *SIAM reviews*, 34(2), pp. 263–294, 1992.
- FRANCISCO FACCHINEI & JONG-SHI PANG. *Finite-dimensional variational inequalities and complementarity problems*, volume I & II of *Springer Series in Operations Research*. Springer Verlag NY. Inc., 2003.
- C. GLOCKER. *Set-Valued Force Laws: Dynamics of Non-Smooth systems*, volume 1 of *Lecture notes in applied mechanics*. Springer Verlag, 2001.
- M. KUNZE & M.D.P. MONTEIRO MARQUES. An introduction to moreau's sweeping process. B. BROGLIATO, editor, *Impact in Mechanical systems: Analysis and Modelling*, volume 551 of *Lecture Notes in Physics*, pp. 1–60. Springer, 2000.
- M. D. P. MONTEIRO MARQUES. *Differential Inclusions in NonSmooth Mechanical Problems : Shocks and Dry Friction*. Birkhauser, Verlag, 1993.
- J.J. MOREAU. Evolution problem associated with a moving convex set in a Hilbert space. *Journal of Differential Equations*, 26, pp. 347–374, 1977.
- D. PANG, J.-S. AN STEWART. Differential variational inequalities. *Mathematical Programming A.*, 2006. submitted, preprint available at <http://www.cis.upenn.edu/davinci/publications/pang-stewart03.pdf>. 

G. SMIRNOV. *Introduction to the theory of Differential inclusions*,
volume 41 of *Graduate Studies in Mathematics*. American
Mathematical Society, Providence, Rhode Island, 2002.

Lecture 3. Solvers for the time-discretized problems.

Vincent Acary

Outline

The Quadratic Programming (QP) problem

The Non Linear Programming (NLP) problem

The linear complementarity problem (LCP)

More general complementarity problems

The Variational Inequalities (VI) and the Quasi-Variational Inequalities (QVI)

Nonsmooth and Generalized equations.

The special case of the unilateral contact with Coulomb's friction

References

References

Lecture 3. Solvers for the time-discretized problems.

Vincent Acary

June 8, 2006

Outline

The Quadratic Programming (QP) problem

The Non Linear Programming (NLP) problem

The linear complementarity problem (LCP)

More general complementarity problems

The Variational Inequalities (VI) and the Quasi-Variational Inequalities (QVI)

Nonsmooth and Generalized equations.

The special case of the unilateral contact with Coulomb's friction

References

References

- 1 Outline
- 2 The Quadratic Programming (QP) problem
 - Definition and Basic properties
 - Algorithms for QP
- 3 The Non Linear Programming (NLP) problem
- 4 The linear complementarity problem (LCP)
 - Definition and Basic properties
 - Link with previous problems
- 5 More general complementarity problems
 - The non linear complementarity problem (NCP)
 - The Mixed Complementarity problem (MiCP)
 - Algorithms for CP
- 6 The Variational Inequalities (VI) and the Quasi-Variational Inequalities (QVI)
 - Definition and basic properties.
 - Algorithms for VI
- 7 Nonsmooth and Generalized equations.
- 8 The special case of the unilateral contact with Coulomb's friction
 - Summary of the time-discretized equations
 - Formulation as a LCP
 - Formulation as NCP
- 9 References

Quadratic Programming (QP) problem

Lecture 3. Solvers for the time-discretized problems.

Vincent Acary

Outline

The Quadratic Programming (QP) problem

Definition and Basic properties

Algorithms for QP

The Non Linear Programming (NLP) problem

The linear complementarity problem (LCP)

More general complementarity problems

The Variational Inequalities (VI) and the Quasi-Variational Inequalities (QVI)

Nonsmooth and Generalized equations.

The special case of the unilateral contact with Coulomb's friction

References

References

Definition (Quadratic Programming (QP) problem)

Let $Q \in \mathbb{R}^{n \times n}$ be a symmetric matrix. Given the matrices $A \in \mathbb{R}^{m_i \times n}$, $C \in \mathbb{R}^{m_e \times n}$ and the vectors $p \in \mathbb{R}^n$, $b \in \mathbb{R}^{m_i}$, $d \in \mathbb{R}^{m_e}$, the Quadratic Programming (QP) problem is to find a vector $z \in \mathbb{R}^n$ denoted by $\text{QP}(Q, p, A, b, C, d)$ such that

$$\begin{aligned} \text{minimize} \quad & q(z) = \frac{1}{2} z^T Q z + p^T z \\ \text{subject to} \quad & A z - b \geq 0 \\ & C z - d = 0 \end{aligned} \quad (1)$$

Associated Lagrangian function

With this constrained optimization problem, a Lagrangian function is usually associated

$$\mathcal{L}(z, \lambda, \mu) = \frac{1}{2} z^T Q z + p^T z - \lambda^T (A z - b) - \mu^T (C z - d) \quad (2)$$

where $(\lambda, \mu) \in \mathbb{R}^{m_i} \times \mathbb{R}^{m_e}$ are the Lagrange multipliers.

Quadratic Programming (QP) problem

Lecture 3. Solvers for the time-discretized problems.

Vincent Acary

Outline

The Quadratic Programming (QP) problem

Definition and Basic properties

Algorithms for QP

The Non Linear Programming (NLP) problem

The linear complementarity problem (LCP)

More general complementarity problems

The Variational Inequalities (VI) and the Quasi-Variational Inequalities (QVI)

Nonsmooth and Generalized equations.

The special case of the unilateral contact with Coulomb's friction

References

References

First order optimality conditions

The first order optimality conditions or Karush-Kuhn-Tucker (KKT) conditions of the QP problem(1) with a set of equality constraints lead to the following MLCP :

$$\begin{cases} \nabla_z \mathcal{L}(\bar{z}, \lambda, \mu) = Q\bar{z} + p - A^T \lambda - C^T \mu = 0 \\ C\bar{z} - d = 0 \\ 0 \leq \lambda \perp A\bar{z} - b \geq 0 \end{cases} . \quad (3)$$

Quadratic Programming (QP) problem

Lecture 3. Solvers for the time-discretized problems.

Vincent Acary

Outline

The Quadratic Programming (QP) problem

Definition and Basic properties

Algorithms for QP

The Non Linear Programming (NLP) problem

The linear complementarity problem (LCP)

More general complementarity problems

The Variational Inequalities (VI) and the Quasi-Variational Inequalities (QVI)

Nonsmooth and Generalized equations.

The special case of the unilateral contact with Coulomb's friction

References

References

Basic properties

- The matrix Q is usually assumed to be a symmetric positive definite (PD).
→ the QP is then convex and the existence and the uniqueness of the minimum is ensured providing that the feasible set $C = \{z, Az - b \geq 0, Cz - d = 0\}$ is none empty.
- Degenerate case.
 - Q is only Semi-Definite Positive (SDP) matrix. (Non existence problems).
 - A (or C) is not full-rank. The constraints are not linearly independent. (Non uniqueness of the Lagrange Multipliers)
 - The strict complementarity does not hold. (we can have $0 = \bar{z} = \lambda = 0$ at the optimal point.)

Quadratic Programming (QP) problem

Lecture 3. Solvers for the time-discretized problems.

Vincent Acary

Outline

The Quadratic Programming (QP) problem

Definition and Basic properties

Algorithms for QP

The Non Linear Programming (NLP) problem

The linear complementarity problem (LCP)

More general complementarity problems

The Variational Inequalities (VI) and the Quasi-Variational Inequalities (QVI)

Nonsmooth and Generalized equations.

The special case of the unilateral contact with Coulomb's friction

References

References

The dual problem and the Lagrangian relaxation

Due to the particular form of the Lagrangian function, the QP problem is equivalent to solving

$$\min_z \max_{\lambda \geq 0, \mu} \mathcal{L}(z, \lambda, \mu) \quad (4)$$

The idea of the Lagrangian relaxation is to invert the min and the max introducing the dual function

$$\theta(\lambda, \mu) = \min_z \mathcal{L}(z, \lambda, \mu) \quad (5)$$

and the dual problem

$$\max_{\lambda \geq 0, \mu} \theta(\lambda, \mu) \quad (6)$$

Quadratic Programming (QP) problem

Lecture 3. Solvers for the time-discretized problems.

Vincent Acary

Outline

The Quadratic Programming (QP) problem

Definition and Basic properties

Algorithms for QP

The Non Linear Programming (NLP) problem

The linear complementarity problem (LCP)

More general complementarity problems

The Variational Inequalities (VI) and the Quasi-Variational Inequalities (QVI)

Nonsmooth and Generalized equations.

The special case of the unilateral contact with Coulomb's friction

References

References

The dual problem and the Lagrangian relaxation

In the particular case of a QP where the matrix Q is non singular, the dual function is equal to :

$$\begin{aligned}\theta(\lambda, \mu) &= \min_z \mathcal{L}(z, \lambda, \mu) = \mathcal{L}(Q^{-1}(A^T \lambda + C^T \mu - p), \lambda, \mu) & (7) \\ &= -\frac{1}{2}(A^T \lambda + C^T \mu - p)^T Q^{-1}(A^T \lambda + C^T \mu - p) + b^T \lambda + d^T \mu & (8)\end{aligned}$$

and we obtain the following dual problem

$$\max_{\lambda \geq 0, \mu} -\frac{1}{2}(A^T \lambda + C^T \mu - p)^T Q^{-1}(A^T \lambda + C^T \mu - p) + b^T \lambda + d^T \mu \quad (9)$$

which is a QP with only inequality constraints of positivity.

Equivalences.

The strong duality theorem asserts that if the matrices Q and $AQ^{-1}A^T$ are symmetric semi-definite positive, then if the primal problem (1) has an optimal solution then the dual has also an optimal solution.

Quadratic Programming (QP) problem

Lecture 3. Solvers for the time-discretized problems.

Vincent Acary

Outline

The Quadratic Programming (QP) problem

Definition and Basic properties

Algorithms for QP

The Non Linear Programming (NLP) problem

The linear complementarity problem (LCP)

More general complementarity problems

The Variational Inequalities (VI) and the Quasi-Variational Inequalities (QVI)

Nonsmooth and Generalized equations.

The special case of the unilateral contact with Coulomb's friction

References

References

Algorithms for QP

For the standard case

- Active sets methods. see Fletcher book's FLETCHER (1987)
- Interior point methods. see BONNANS *et al.* (2003)
- Projection and splitting methods for large scale problems.

For the degenerate case,

- Lagrangian relaxation
- Active sets methods. see FLETCHER (1993).
- Proximal point algorithm

Interest of the QP problem

- Reliability with SDP matrix
- Minimization algorithms imply stability

Definition (Nonlinear Programming (NLP) Problem)

Given a differentiable function $\theta : \mathbb{R}^n \mapsto \mathbb{R}$, and two differentiable mappings $g : \mathbb{R}^n \mapsto \mathbb{R}^{m_i}$ $g : \mathbb{R}^n \mapsto \mathbb{R}^{m_e}$, the Nonlinear Programming (NLP) problem is to find a vector $z \in \mathbb{R}^n$ such that

$$\begin{aligned} & \text{minimize} && f(z) \\ & \text{subject to} && g(z) \geq 0 \\ & && h(z) = 0 \end{aligned} \tag{10}$$

Associated Lagrangian function

The Lagrangian of this NLP problem is introduced as follows

$$\mathcal{L}(z, \lambda, \mu) = f(z) - \lambda^T g(z) - \mu^T h(z) \tag{11}$$

where $(\lambda, \mu) \in \mathbb{R}^{m_i} \times \mathbb{R}^{m_e}$ are the Lagrange multipliers.

First order optimality conditions

The Karush-Kuhn-Tucker (KKT) necessary conditions for the NLP problem are given the following NCP:

$$\begin{cases} \nabla_z \mathcal{L}(z, \lambda, \mu) = \nabla_z f(z) - \nabla_z^T g(z) \lambda - \nabla_z^T h(z) \mu = 0 \\ h(z) = 0 \\ 0 \leq \lambda \perp g(z) \geq 0 \end{cases} \quad (12)$$

Linear Complementarity Problem (LCP)

Lecture 3. Solvers for the time-discretized problems.

Vincent Acary

Outline

The Quadratic Programming (QP) problem

The Non Linear Programming (NLP) problem

The linear complementarity problem (LCP)

Definition and Basic properties

Link with previous problems

More general complementarity problems

The Variational Inequalities (VI) and the Quasi-Variational Inequalities (QVI)

Nonsmooth and Generalized equations.

The special case of the unilateral contact with Coulomb's friction

References

References

Definition (Linear Complementarity Problem (LCP))

Given $M \in \mathbb{R}^{n \times n}$ and $q \in \mathbb{R}^n$, the Linear Complementarity Problem, is to find a vector $z \in \mathbb{R}^n$, denoted by $LCP(M, q)$ such that

$$0 \leq z \perp Mz + q \geq 0 \quad (13)$$

The inequalities have to be understood component-wise and the relation $x \perp y$ means $x^T y = 0$.

Linear Complementarity Problem (LCP)

Lecture 3. Solvers for the time-discretized problems.

Vincent Acary

Outline

The Quadratic Programming (QP) problem

The Non Linear Programming (NLP) problem

The linear complementarity problem (LCP)

Definition and Basic properties

[Link with previous problems](#)

[More general complementarity problems](#)

The Variational Inequalities (VI) and the Quasi-Variational Inequalities (QVI)

[Nonsmooth and Generalized equations.](#)

[The special case of the unilateral contact with Coulomb's friction](#)

[References](#)

[References](#)

Basic properties

- The $LCP(M, q)$ is that it admits a unique solution for all $q \in \mathbb{R}^n$ if and only if M is a P-matrix.
A P-Matrix is a matrix with all of its principal minors positive, see (COTTLE *et al.*, 1992 ; MURTY, 1988).
- In the worst case, the problem is N-P hard .i.e. there is no polynomial-time algorithm to solve it.
- In practice, this "P-matrix" assumption is difficult to ensure via numerical computation, but a definite positive matrix (not necessarily symmetric), which is a P-matrix is often encountered.

Linear Complementarity Problem (LCP)

Lecture 3. Solvers for the time-discretized problems.

Vincent Acary

Outline

The Quadratic Programming (QP) problem

The Non Linear Programming (NLP) problem

The linear complementarity problem (LCP)

Definition and Basic properties

Link with previous problems

More general complementarity problems

The Variational Inequalities (VI) and the Quasi-Variational Inequalities (QVI)

Nonsmooth and Generalized equations.

The special case of the unilateral contact with Coulomb's friction

References

References

Definition (Mixed Linear Complementarity Problem (MLCP))

Given the matrices $A \in \mathbb{R}^{n \times n}$, $B \in \mathbb{R}^{m \times m}$, $C \in \mathbb{R}^{n \times m}$, $D \in \mathbb{R}^{m \times n}$, and the vectors $a \in \mathbb{R}^n$, $b \in \mathbb{R}^m$, the Mixed Linear Complementarity Problem denoted by $\text{MLCP}(A, B, C, D, a, b)$ consists in finding two vectors $u \in \mathbb{R}^n$ and $v \in \mathbb{R}^m$ such that

$$\begin{cases} Au + Cv + a = 0 \\ 0 \leq v \perp Du + bv + b \geq 0 \end{cases} \quad (14)$$

Comments

The MLCP is a mixture between a LCP and a system of linear equations. Clearly, if the matrix A is non singular, we may solve the embedded linear system to obtain u and then reduced the MCLP to a LCP with $q = b - DA^{-1}a$, $M = b - DA^{-1}C$.

Linear Complementarity Problem (LCP)

Lecture 3. Solvers for the time-discretized problems.

Vincent Acary

Outline

The Quadratic Programming (QP) problem

The Non Linear Programming (NLP) problem

The linear complementarity problem (LCP)

Definition and Basic properties

Link with previous problems

More general complementarity problems

The Variational Inequalities (VI) and the Quasi-Variational Inequalities (QVI)

Nonsmooth and Generalized equations.

The special case of the unilateral contact with Coulomb's friction

References

References

Link with the QP

If the matrix M of $\text{LCP}(M, q)$ is symmetric PD, a QP formulation of (13) is direct into $\text{QP}(M, q, I_{n \times n}, 0_n, \emptyset, \emptyset)$, $m_i = n$, $m_e = 0$. For a non symmetric PD matrix M , the inner product may be chosen as an objective function:

$$\begin{aligned} & \text{minimize} && q(z) = z^T(q + Mz) \\ & \text{subject to} && q + Mz \geq 0 \\ & && z \geq 0 \end{aligned} \quad (15)$$

and to identify (15) with (1), we set

$Q = M + M^T$, $Az = (Mz, z)^T$, $b = (-q, 0)^T$, $m_i = 2n$, $m_e = 0$. Moreover, the first order optimality condition may be written as

$$\begin{cases} (M + M^T)\bar{z} + p - A^T\lambda - M^T\mu \geq 0 \\ z^T((M + M^T)\bar{z} + p - A^T\lambda - M^T\mu) = 0 \\ \mu \geq 0 \\ u^T(q + M\bar{z}) = 0 \end{cases} \quad (16)$$

Let us recall that a non symmetric matrix M is PD if and only if its symmetric part, $(M + M^T)$ is PD.

Linear Complementarity Problem (LCP)

Lecture 3. Solvers for the time-discretized problems.

Vincent Acary

Outline

The Quadratic Programming (QP) problem

The Non Linear Programming (NLP) problem

The linear complementarity problem (LCP)

Definition and Basic properties

Link with previous problems

More general complementarity problems

The Variational Inequalities (VI) and the Quasi-Variational Inequalities (QVI)

Nonsmooth and Generalized equations.

The special case of the unilateral contact with Coulomb's friction

References

References

Algorithms for LCP

- Splitting based methods
- Generalized Newton methods
- Interior point method
- Pivoting based method
- QP methods for a SDP matrix.

Definition (Complementarity Problem (CP))

Given a cone $K \subset \mathbb{R}^n$ and a mapping $F : \mathbb{R}^n \mapsto \mathbb{R}^n$, the Complementarity Problem is to find a vector $x \in \mathbb{R}^n$ denoted by $\text{CP}(K, F)$ such that

$$K \ni x \perp F(x) \in K^* \quad (17)$$

where K^* is the dual (negative polar) cone of K defined by

$$K^* = \{d \in \mathbb{R}^n, v^T d \geq 0, \forall v \in K\} \quad (18)$$

Definition (Nonlinear Complementarity Problem (NCP))

Given a mapping $F : \mathbb{R}^n \mapsto \mathbb{R}^n$, find a vector $z \in \mathbb{R}^n$ denoted by NCP(F) such that

$$0 \leq z \perp F(z) \geq 0 \quad (19)$$

Complementarity problems (CP)

Lecture 3. Solvers for the time-discretized problems.

Vincent Acary

Outline

The Quadratic Programming (QP) problem

The Non Linear Programming (NLP) problem

The linear complementarity problem (LCP)

More general complementarity problems

The non linear complementarity problem (NCP)

The Mixed Complementarity problem (MiCP)
Algorithms for CP

The Variational Inequalities (VI) and the Quasi-Variational Inequalities (QVI)

Nonsmooth and Generalized equations.

The special case of the unilateral contact with Coulomb's friction

References

References

Definition (Mixed Nonlinear Complementarity Problem (MiCP))

Given two mappings $F : \mathbb{R}^{n_1} \times \mathbb{R}_+^{n_2} \mapsto \mathbb{R}^{n_1}$ and $H : \mathbb{R}^{n_1} \times \mathbb{R}_+^{n_2} \mapsto \mathbb{R}^{n_2}$. The MiCP is to find a pair of a vectors $u, v \in \mathbb{R}^{n_1} \times \mathbb{R}^{n_2}$ such that

$$\begin{cases} G(u, v) = 0 \\ 0 \leq v \perp H(u, v) \geq 0 \end{cases} \quad (20)$$

The following definition is equivalent:

Definition (Mixed Complementarity Problem (MiCP))

Given two sets of indexes C (for constrained) and F (for free) forming a partition of the set $\{1, 2, \dots, n\}$ and two mappings $F_C : \mathbb{R}^n \mapsto \mathbb{R}^C$, $F_F : \mathbb{R}^n \mapsto \mathbb{R}^F$, such that $f + c = n$, find a vector $z \in \mathbb{R}^n$ such that

$$\begin{cases} F_F(z) = 0, z_F \text{ free} \\ 0 \leq z_C \perp F_C(z) \geq 0 \end{cases} \quad (21)$$

Algorithms for Complementarity problems (CP)

- General Complementarity problems. (unstructures K)
 - General algorithms for VI/CP. (see after)
 - Slow and inefficient algorithm.
- CP on polyhedral cone. (NLP, MiCP)
 - Josephy-Newton method. Linearizing procedure of F . Newton scheme. Successive LCP resolution.
 - Reformulation into a non equations. Use of generalized Newton method.

The Variational Inequalities (VI)

Lecture 3. Solvers for the time-discretized problems.

Vincent Acary

Outline

The Quadratic Programming (QP) problem

The Non Linear Programming (NLP) problem

The linear complementarity problem (LCP)

More general complementarity problems

The Variational Inequalities (VI) and the Quasi-Variational Inequalities (QVI)

Definition and basic properties.

Algorithms for VI

Nonsmooth and Generalized equations.

The special case of the unilateral contact with Coulomb's friction

References

References

Definition (Variational Inequality (VI) problem)

Let X be a nonempty subset of \mathbb{R}^n and let F be a mapping from \mathbb{R}^n into itself. The Variational Inequality problem, denoted by $VI(X, F)$ is to find a vector $z \in \mathbb{R}^n$ such that

$$F(z)^T(y - z) \geq 0, \forall y \in X \quad (22)$$

The Variational Inequalities (VI)

Lecture 3. Solvers for the time-discretized problems.

Vincent Acary

Outline

The Quadratic Programming (QP) problem

The Non Linear Programming (NLP) problem

The linear complementarity problem (LCP)

More general complementarity problems

The Variational Inequalities (VI) and the Quasi-Variational Inequalities (QVI)

Definition and basic properties.

Algorithms for VI

Nonsmooth and Generalized equations.

The special case of the unilateral contact with Coulomb's friction

References

References

Basic properties

- the set X is assumed to be closed and convex. In most of the applications, X is polyhedral. The function is also assumed to be continuous, nevertheless some VI are defined for set-valued mappings.
- If X is a closed set and F continuous, the solution set of $\text{VI}(X, F)$ denoted by $\text{SOL}(X, F)$ is always a closed set.
- A geometrical interpretation of the $\text{VI}(X, F)$ leads to the equivalent formulation in terms of inclusion into a normal cone of X , i.e.,

$$-F(x) \in N_{Xx} \quad (23)$$

or equivalently

$$0 \in F(x) + N_{Xx} \quad (24)$$

The Variational Inequalities (VI)

Lecture 3. Solvers for the time-discretized problems.

Vincent Acary

Outline

The Quadratic Programming (QP) problem

The Non Linear Programming (NLP) problem

The linear complementarity problem (LCP)

More general complementarity problems

The Variational Inequalities (VI) and the Quasi-Variational Inequalities (QVI)

Definition and basic properties.

Algorithms for VI

Nonsmooth and Generalized equations.

The special case of the unilateral contact with Coulomb's friction

References

References

Basic properties

- It is noteworthy that the $VI(X, F)$ extends the problem of solving non linear equations, $F(x) = 0$ taking $X = \mathbb{R}^n$.
- If F is affine function, $F(x) = Mx + q$, the $VI(X, F)$ is called Affine VI denoted by, $AVI(X, F)$.
- If X is polyhedral, we say that the $VI(X, F)$ is linearly constrained, or that is a linearly constrained VI. A important case is the box constrained VI where the set X is a closed rectangle (possibly unbounded) of \mathbb{R}^n , i.e

$$K = \{x \in \mathbb{R}^n, -\infty \leq a_i \leq x \leq b_i \leq +\infty\} \quad (25)$$

The Variational Inequalities (VI)

Lecture 3. Solvers for the time-discretized problems.

Vincent Acary

Outline

The Quadratic Programming (QP) problem

The Non Linear Programming (NLP) problem

The linear complementarity problem (LCP)

More general complementarity problems

The Variational Inequalities (VI) and the Quasi-Variational Inequalities (QVI)

Definition and basic properties.

Algorithms for VI

Nonsmooth and Generalized equations.

The special case of the unilateral contact with Coulomb's friction

References

References

Algorithms for VI

- General VI (unstructured closed convex set K).
Reformulation with the normal map associated the $VI(K, F)$

$$\mathbf{F}_K^{nor}(z) = F(\Pi_K(z)) + z - \Pi_K(z) \quad (26)$$

A solution x of the $VI(K, F)$ is given by $\mathbf{F}_K^{nor}(z) = 0$ with $x = \Pi_K(z)$

- General projection algorithm for VI/CP. (Fixed point). Need at least the definition of the projection onto the cone.
→ Slow and inefficient algorithm.
- Newton Methods for VI/CP. Need the definition of the projection and the Jacobian of $\mathbf{F}_K^{nor}(z)$
→ Difficult computation for a unstructured closed convex set K
- If the problem has a better structure, the problem is then reformulated into a specific complementarity problem through a nonsmooth equation.

Definition (Generalized Equation (GE) problem)

Let $\Omega \subset \mathbb{R}^n$ be an open set. Given a continuously Fréchet differentiable mapping $F : \Omega \subset \mathbb{R}^n \mapsto \mathbb{R}^n$ and a maximal monotone operator $T : \mathbb{R}^n \rightsquigarrow \mathbb{R}^n$, find a vector $z \in \mathbb{R}^n$ such that

$$0 \in F(z) + T(z) \tag{27}$$

Basic properties

The GE problem is closely related to CP problems and to the NLP. For instance, the NCP (19) can be represented into a GE by

$$0 \in F(z) + N_{\mathbb{R}_+^n}(z) \quad (28)$$

and the MCP (12), which provides the KKT necessary conditions for the NLP can be casted into a GE of the form

$$0 \in F(z) + N_K(z), z \in \mathbb{R}^{n+m_e+m_i} \quad (29)$$

with

$$\begin{cases} F(z) = \begin{bmatrix} \nabla \mathcal{L}(z, u, v) \\ -g(z) \\ -h(z) \end{bmatrix} \\ K = \mathbb{R}^n \times \mathbb{R}_+^{m_i} \times \mathbb{R}^{m_e} \end{cases} \quad (30)$$

Key idea

Reformulation of the Generalized equation into a non smooth equation with good properties (semi-smoothness)

$$0 \in F(z) + T(z) \Rightarrow \Phi(z) = 0 \quad (31)$$

Apply Generalized Newton Method to the equation $\Phi(z) = 0$.

Generalized Newton Method

Solve the equation

$$\Phi(z) = 0 \quad (32)$$

by the extended linearizing procedure.

$$z_{k+1} = z_k - H_k^{-1}(x_k)\Phi(x_k) \quad (33)$$

where $H_k(x_k)$ is an element of the subdifferential $\partial\Phi(x_k)$.

Definition

NCP functions. A function $\psi : \mathbb{R}^2 \rightarrow \mathbb{R}$ is called a NCP function if it satisfies the following relation

$$\psi(w, z) = 0 \Leftrightarrow 0 \leq w \perp z \geq 0 \quad (34)$$

Example

$$\psi_{\min}(w, z) = \min(w, z) \quad (35)$$

$$\psi_{FB}(w, z) = \sqrt{z^2 + w^2} - z - w \text{ (Fischer-Burmeister function)} \quad (36)$$

$$\psi_{FB1}(w, z) = \lambda(\psi_{FB}) - (1 - \lambda) \max(0, z) \max(0, w) \text{ with } \lambda \in]0, 1[\quad (37)$$

$$\psi_{\text{smooth}}(w, z) = wz + \frac{1}{2} \min^2(0, z + w) \quad (38)$$

Basic properties

- If the NCP function is everywhere differentiable, the Jacobian is singular at the solution point
- The NCP function needs to be semi-smooth to obtain convergence results.
- Line search methods based on a merit function. For instance,

$$\Psi = \frac{1}{2} \Phi^T(z) \Phi(z) \quad (39)$$

For Fischer-Burmeister function, this function is differentiable everywhere.

→ Stability (global convergence) and local quadratic convergence results.

Summary of the time-discretized equations

Lecture 3. Solvers for the time-discretized problems.

Vincent Acary

Outline

The Quadratic Programming (QP) problem

The Non Linear Programming (NLP) problem

The linear complementarity problem (LCP)

More general complementarity problems

The Variational Inequalities (VI) and the Quasi-Variational Inequalities (QVI)

Nonsmooth and Generalized equations.

The special case of the unilateral contact with Coulomb's friction

Summary of the time-discretized equations

Formulation as a LCP

Formulation as NCP

References

References

The discretization of the equation of motion and of the contact law can be summarized in the following system :

$$(\mathcal{P}_{LR}) \quad \begin{cases} U_{k+1} = WP_{k+1} + V_{free} \\ \text{NonSmoothLaw}[U_{k+1}, P_{k+1}] \end{cases} \quad (\text{Unilateral contact, friction and})$$

Summary of the time-discretized equations

Lecture 3. Solvers for the time-discretized problems.

Vincent Acary

Outline

The Quadratic Programming (QP) problem

The Non Linear Programming (NLP) problem

The linear complementarity problem (LCP)

More general complementarity problems

The Variational Inequalities (VI) and the Quasi-Variational Inequalities (QVI)

Nonsmooth and Generalized equations.

The special case of the unilateral contact with Coulomb's friction

Summary of the time-discretized equations

Formulation as a LCP

Formulation as NCP

References

References

$$(\mathcal{P}_{LM}) \quad \left\{ \begin{array}{ll} Mv_{k+1} + \hat{f} = p_{k+1} + G^T \mu_{k+1} & \\ \widehat{G} v_{k+1} = 0 & \text{(Bilateral Constraints)} \\ U_{k+1} = H^T v_{k+1}, p_{k+1} = HP_{k+1} & \text{(Kinematics Relations)} \\ \text{NonSmoothLaw}[U_{k+1}, P_{k+1}] & \text{(Unilateral contact, friction)} \end{array} \right.$$

where

$$\hat{f} = Mv_k + [-hCv_k - hKq_k - h^2\theta Kv_k + h[\theta(F_{\text{ext}})_{k+1}] + (1-\theta)(F_{\text{ext}})_k]$$

Summary of the time-discretized equations

Lecture 3. Solvers for the time-discretized problems.

Vincent Acary

Outline

The Quadratic Programming (QP) problem

The Non Linear Programming (NLP) problem

The linear complementarity problem (LCP)

More general complementarity problems

The Variational Inequalities (VI) and the Quasi-Variational Inequalities (QVI)

Nonsmooth and Generalized equations.

The special case of the unilateral contact with Coulomb's friction

Summary of the time-discretized equations

Formulation as a LCP

Formulation as NCP

References

References

$$(\mathcal{P}) \quad \left\{ \begin{array}{ll} F(v_{k+1}) = p_{k+1} & \text{(Non linear Discret)} \\ G(v_{k+1}) = 0 & \text{(Bilateral Constrai)} \\ U_{k+1} = H^*(q_{k+1})v_{k+1}, r_{k+1} = H(q_{k+1})P_{k+1} & \text{(Kinematics Relati)} \\ \text{NonSmoothLaw}[U_{k+1}, P_{k+1}] & \text{(Unilateral contact)} \end{array} \right.$$

Let us consider the problem (\mathcal{P}_{LM}) in which the NonSmoothLaw corresponds to the frictionless unilateral contact. In this case, the problem (\mathcal{P}_{LM}) can be written under the form:

$$\begin{cases} \widehat{M}v_{k+1} + \widehat{f} - HP_{k+1} - G^T\mu_{k+1} = 0 \\ \widehat{G}v_{k+1} = 0 \\ U_{k+1} = H^T v_{k+1} \\ 0 \leq U_{k+1} \perp P_{k+1} \geq 0 \end{cases} \quad (40)$$

Second order cone

Contrary to the 2D frictional contact problem, the 3D case can not be cast directly into a LCP, because of the non linear nature of the section of the friction cone, $C(\mu r_n)$

$$C(\mu r_n) = \{ \lambda_t, \sigma(\lambda_t) = \mu r_n - \|\lambda_t\| \geq 0 \} \quad (41)$$

→ Facetization of $C(\mu r_n)$.

Outer approximation

the friction disk $C(\mu r_n)$ can be approximated by an outer polygon :

$$C_{outer}(\mu r_n) = \bigcap_{i=1}^{\nu} C_i(\mu r_n) \quad \text{with } C_i(\mu r_n) = \{ \lambda_t, \sigma_i(\lambda_t) = \mu r_n - c_i^T \lambda_t \geq 0 \} \quad (42)$$

We now assume that the contact law (??) is of the form

$$-u_t \in N_{C_{outer}(\mu r_n)}(r_t) \quad (43)$$

Outer approximation

the normal cone to $C_{outer}(\mu r_n)$ is given by :

$$N_{C_{outer}(\mu r_n)}(r_t) = \sum_{i=1}^{\nu} N_{C_i}(\mu r_n)(r_t) \quad (44)$$

and the inclusion can be stated as:

$$-u_t \in \sum_{i=1}^{\nu} -\kappa_i \partial \sigma_i(\lambda_t), \quad 0 \leq \sigma_i(\lambda_t) \perp \kappa_i \geq 0 \quad (45)$$

Since $\sigma_i(\lambda_t)$ is linear with the respect to λ_t , we obtain the following LCP :

$$-u_t \in \sum_{i=1}^{\nu} -\kappa_i c_i, \quad 0 \leq \sigma_i(\lambda_t) \perp \kappa_i \geq 0 \quad (46)$$

Inner approximation

The idea is to approach the friction disk by an interior polygon with ν edges. (e.g. Fig.1b)):

$$C_{inner}(\mu r_n) = \{\lambda_t = D\beta, \beta \geq 0, \mu r_n \geq e_T \beta\} \quad (47)$$

where $e = [1, \dots, 1]^T \in \mathbb{R}^\nu$, the columns of the matrix D are the directions vectors d_j which represent the vertices of the polygon. For the sake of simplicity, we assumed that for every i there is j such that $d_i = -d_j$.

Following the same process as in the previous case and rearranging the equation, we obtain the following LCP :

$$\begin{cases} r_t = D\beta \\ 0 \leq \beta \perp \lambda e + D^T v_t \geq 0 \\ 0 \leq \lambda \perp \lambda \perp \mu r_n - e_T \beta \geq 0 \end{cases} \quad (48)$$

Lecture 3. Solvers for the time-discretized problems.

Vincent Acary

Outline

The Quadratic Programming (QP) problem

The Non Linear Programming (NLP) problem

The linear complementarity problem (LCP)

More general complementarity problems

The Variational Inequalities (VI) and the Quasi-Variational Inequalities (QVI)

Nonsmooth and Generalized equations.

The special case of the unilateral contact with Coulomb's friction

Summary of the time-discretized equations

Formulation as a LCP

Formulation as NCP

References

References

c

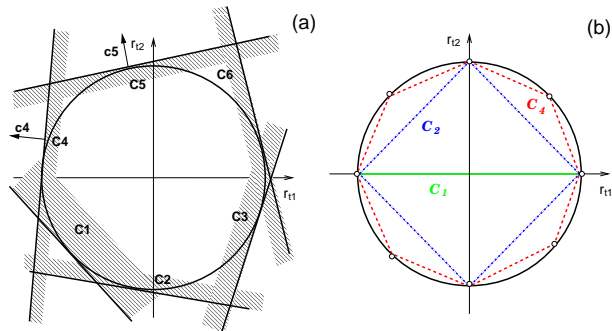

Figure: Approximation of the base of the Coulomb cone by an outer approximation (a) and by an interior 2ν -gon (b)

Lecture 3. Solvers for the time-discretized problems.

Vincent Acary

Outline

The Quadratic Programming (QP) problem

The Non Linear Programming (NLP) problem

The linear complementarity problem (LCP)

More general complementarity problems

The Variational Inequalities (VI) and the Quasi-Variational Inequalities (QVI)

Nonsmooth and Generalized equations.

The special case of the unilateral contact with Coulomb's friction

Summary of the time-discretized equations

Formulation as a LCP

Formulation as NCP

References

References

Comments

- Induced anisotropy in the Coulomb's friction
- The LCP is not necessarily well-posedness

A direct NCP for the 3D frictional contact.

Let us denote by $\xi(u_t) = \|u_t\|$ the norm of the tangential velocity, and by $\sigma(r_t) = \mu r_n - \|r_t\|$ the friction saturation. The problem of contact friction (??) can be easily reformulated into the following NCP:

$$\begin{cases} r_t \xi + \|r_t\| u_t = 0 \\ \xi(u_t) \geq 0, \sigma(r_t) \geq 0, \sigma(r_t) \cdot \xi(u_t) = 0 \end{cases} \quad (49)$$

Two drawbacks are inherent to the previous NCP formulation. Firstly, the NCP formulation is fully nonlinear and it may be difficult to find the well-posed mapping F of the formulation (19).

Lecture 3. Solvers for the time-discretized problems.

Vincent Acary

Outline

The Quadratic Programming (QP) problem

The Non Linear Programming (NLP) problem

The linear complementarity problem (LCP)

More general complementarity problems

The Variational Inequalities (VI) and the Quasi-Variational Inequalities (QVI)

Nonsmooth and Generalized equations.

The special case of the unilateral contact with Coulomb's friction

Summary of the time-discretized equations

Formulation as a LCP

Formulation as NCP

References

References

Thank you for your attention.

Lecture 3. Solvers for the time-discretized problems.

Vincent Acary

Outline

The Quadratic Programming (QP) problem

The Non Linear Programming (NLP) problem

The linear complementarity problem (LCP)

More general complementarity problems

The Variational Inequalities (VI) and the Quasi-Variational Inequalities (QVI)

Nonsmooth and Generalized equations.

The special case of the unilateral contact with Coulomb's friction

References

References

J.F. BONNANS, J.C. GILBERT, C. LEMARCHAL & C.A. SAGASTIZBAL. *Numerical Optimization: Theoretical and Practical Aspects*. Springer-Verlag, 2003.

R. W. COTTLE, J. PANG & R. E. STONE. *The linear complementarity problem*. Academic Press, Inc., Boston, MA, 1992.

R. FLETCHER. *Practical Methods of Optimization*. Chichester: John Wiley & Sons, Inc., 1987.

R. FLETCHER. Resolving degeneracy in quadratic programming. *Annals of Operations Research*, 46–47(1–4), pp. 307–334, 1993.

K.G. MURTY. *Linear and Nonlinear Programming*. Heldermann, 1988. available at <http://www-personal.engin.umich.edu/~murty/book/LCPbook/>.