



HAL
open science

UML/MARTE CCSL, Signal and Petri nets

Frédéric Mallet, Charles André

► **To cite this version:**

Frédéric Mallet, Charles André. UML/MARTE CCSL, Signal and Petri nets. [Research Report] RR-6545, 2008. inria-00283077v1

HAL Id: inria-00283077

<https://inria.hal.science/inria-00283077v1>

Submitted on 29 May 2008 (v1), last revised 12 Jun 2008 (v4)

HAL is a multi-disciplinary open access archive for the deposit and dissemination of scientific research documents, whether they are published or not. The documents may come from teaching and research institutions in France or abroad, or from public or private research centers.

L'archive ouverte pluridisciplinaire **HAL**, est destinée au dépôt et à la diffusion de documents scientifiques de niveau recherche, publiés ou non, émanant des établissements d'enseignement et de recherche français ou étrangers, des laboratoires publics ou privés.



INSTITUT NATIONAL DE RECHERCHE EN INFORMATIQUE ET EN AUTOMATIQUE

UML/MARTE CCSL, Signal and Petri nets

Frédéric Mallet — Charles André

N° ????

May 2008

Thème COM



*R*apport
de recherche



UML/MARTE CCSL, Signal and Petri nets

Frédéric Mallet*, Charles André*

Thème COM — Systèmes communicants
Projet Aoste

Rapport de recherche n° 7777 — May 2008 — 21 pages

Abstract: UML goal of being a general-purpose modeling language discards the possibility to adopt too precise and strict a semantics. Users are to refine or define the semantics in their domain specific profiles. In the UML Profile for Modeling and Analysis of Real-Time and Embedded systems, we have defined a broadly expressive Time Model to provide a generic timed interpretation for UML models. Our clock constraint specification language supports the specification of systems with multiple clock domains. Starting with a priori independent clocks, we progressively compose them to get a family of possible executions. Our language supports both synchronous and asynchronous compositions, just like the synchronous language Signal, but also allows explicit non determinism. In this paper, we give a formal semantics to a core subset of MARTE clock constraint languages and we give an equivalent interpretation of this kernel in two other very different formal languages, Signal and Time Petri Nets.

Key-words: UML, MARTE, CCSL, logical time, semantics, Signal, Time Petri Net

This work is part of the platform OpenEmbedd: <http://openembedd.org>

* Université de Nice-Sophia Antipolis

UML/MARTE CCSL, Signal et réseaux de Petri

Résumé : UML visant à être un langage général se doit d'adopter une sémantique large pour couvrir un ensemble important de domaines. Ainsi, les points de variation sémantique ouverts par la spécification doivent être exploités par des profils pour raffiner voire même définir une sémantique adaptée à un domaine donné. C'est que nous avons fait dans le profil MARTE (UML Profile for Modeling and Analysis of Real-Time and Embedded systems) et plus spécifiquement son modèle de temps. Ce profil de temps vise à donner une interprétation précise mais suffisamment large pour permettre une interprétation temporelle des modèles UML. Ce modèle de temps comprend un langage de spécification de contraintes qui permet de contraindre progressivement des comportements *a priori* indépendants pour isoler une famille de comportements acceptables. La suite des instants d'activation des comportement contraints est appelée *horloge logique*. Ce langage propose des mécanismes de compositions synchrones et asynchrones des horloges logiques et ressemble en cela beaucoup au langage Signal. Il permet aussi d'exprimer du non-déterminisme explicite et est également inspiré de modèles issus de la théorie de la concurrence, comme les réseaux de Petri.

Ce papier présente la sémantique formelle d'un sous-ensemble représentatif des contraintes de MARTE CCSL en se limitant au temps discret. Pour élargir la communauté et pour faire le lien avec les nombreux travaux existants nous donnons une interprétation de ce sous-ensemble de contraintes en Signal et en réseaux de Petri.

Mots-clés : UML, MARTE, CCSL, temps logique, sémantique, Signal, Réseaux de Petri

1 Introduction

The Unified Modeling Language (UML) [1] aims at being a unified and general-purpose modeling language. Its semantics is purposely loose to cover a large domain and introduces so-called *semantic variation points* that provide for extensions to refine (or even define) a semantics when required for a specific domain. These extensions are to be defined in the context of a UML Profile. In the domain of real-time and embedded (RTE) systems, the Object Management Group (OMG) has recently adopted the UML Profile for Modeling and Analysis of Real-Time and Embedded systems (MARTE) [2], which is currently in the finalization phase. In its foundations, MARTE defines a broadly expressive Time Model to provide for a generic timed interpretation of UML models. The idea is to precisely define a semantics within the Profile rather than allowing tools for giving their own, possibly incompatible with other tools of the same domain.

MARTE Time Structure is heavily inspired by the Tagged Signal Model [3], which intends to define a common framework for comparing several Models of Computation and Communication in the RTE domain, and from various works around synchronous languages [4] and more generally polychronous/multiclock languages well-suited to specify Globally Asynchronous and Locally Synchronous (GALS) systems. The concrete syntax of our language, called *Clock Constraint Specification Language* (CCSL), is part of MARTE Profile but is not normative and not based on any existing language to let tool vendors choose their own technology. Our goal has been to use explicit keywords that denote usual concepts of the domain (periodic, sporadic, sampling. . .).

A comprehensive *informal* description of CCSL has previously been presented in [5] and a partial *formal declarative* description is available in [6]. Using a declarative mathematical description allows for being language independent. However, when constraints are not incompatible they should enforce a causal relationship between UML model elements and thus provide a support to build a real-time UML simulator. To implement CCSL and produce acceptable executions, *i.e.*, compatible with all constraints, it may be interesting to transform it into equivalent formalisms that already benefit from analysis tools. This paper compares a representative selection of CCSL constraints with two very different languages: Petri nets [7] and Signal [8]. Additionally, these two languages being general enough, such a description should help a broad community of the concurrency theory understand MARTE clock constraints.

Section 2 starts with a general introduction to CCSL and describe general assumptions made on Petri nets and Signal to allow for a comparison. The following sections gives for each of the selected constraints, its rationale, a mathematical definition, its equivalent in Petri net and/or its equivalent in Signal, when there is an equivalent. Section 7 illustrates the use of the constraints on an unusual example that process Easter days. This section also introduces the graphical representation of CCSL clock constraints. The graphical representation is not part of MARTE yet and will be proposed to the OMG Revision Task Force for being integrated in next MARTE revision.

2 Formalisms under consideration

2.1 MARTE Time Structure

A *Clock* is a 5-tuple $\langle \mathcal{I}, \prec, \mathcal{D}, \lambda, u \rangle$ where \mathcal{I} is a set of instants (possibly infinite), \prec is a quasi-order relation on \mathcal{I} , named *strict precedence*, \mathcal{D} is a set of labels, $\lambda : \mathcal{I} \rightarrow \mathcal{D}$ is a labeling function, u is a symbol, standing for a *unit*. In this paper, we only consider the clock temporal structure (or *pure clock*), *i.e.*, the *ordered set* $\langle \mathcal{I}, \prec \rangle$ and the values are never mentioned. \prec is a total, irreflexive, and transitive binary relation on \mathcal{I} .

A *discrete-time clock* is a clock with a discrete set of instants \mathcal{I} . Since \mathcal{I} is discrete, it can be indexed by natural numbers in a way that respects the ordering on \mathcal{I} : let $\mathbb{N}^* = \mathbb{N} \setminus \{0\}$, $\text{idx} : \mathcal{I} \rightarrow \mathbb{N}^*$, $\forall i \in \mathcal{I}$, $\text{idx}(i) = k$ if and only if i is the k^{th} instant in \mathcal{I} . We restrict the discussion to discrete-time clocks and do not consider dense time at all. All operators presented are presented with a restricted semantics, assuming that clocks are discrete, whereas these operators may have a more general semantics.

For any discrete-time time structure $c = \langle \mathcal{I}_c, \prec_c \rangle$, $c[k]$ denotes the k^{th} instant in \mathcal{I}_c (*i.e.*, $k = \text{idx}_c(c[k])$). For any instant $i \in \mathcal{I}_c$, i° is the unique immediate predecessor of i in \mathcal{I}_c and i° is the unique immediate successor of i in \mathcal{I}_c , if any. To simplify computations, we assume a *virtual* instant $c[0]$, so that $c[0] \equiv {}^\circ c[1]$.

A *Time Structure* is a pair $\langle C, \preceq \rangle$ where C is a set of clocks, \preceq is a binary relation on $\bigcup_{c \in C} \mathcal{I}_c$, named *precedence*. \preceq is reflexive and transitive. From \preceq we derive four new instant relations: *Coincidence* ($\equiv \triangleleft \preceq \cap \succ$), *Strict precedence* ($\prec \triangleleft \preceq \setminus \equiv$), *Independence* ($\parallel \triangleleft \preceq \cup \succ$), and *Exclusion* ($\# \triangleleft \preceq \cup \succ$).

2.2 Signal

In Signal language, a signal is a sequence of values of the same type, which are present at some instants. The set of instants where a signal is present is the clock of the signal (not to be mistaken with CCSL clocks). As in MARTE, the physical amount of time between two values is not relevant. The Signal language has two kinds of operators. *Monochronous* operators act only on synchronous signals, *i.e.*, signals that are always present at the same instants, signals that have the same clock. *Polychronous* operators act on signals with any clock and their result may have another clock. In this paper, we only consider the time structure of MARTE and relations on instants, we do not use the labeling function. So CCSL clocks are very similar to signals and pure clocks compare to Signal clocks (or *pure signals*, type event). CCSL clock relations compare to Signal polychronous operators. In this paper, we never discuss equivalent for Signal monochronous operators that would work on labels associated with instants rather than the time structure itself.

2.3 Time Petri net

MARTE Time model conceptually differs from Petri's work on concurrency theory [7]. Petri's theory restricts coincidence to single points in space-time. In our model, the foundational

relationship *coincidence* gathers *a priori* independent points (instants) to reflect design choices.

Petri nets have well-established mathematical foundations and offer rich analysis capabilities. Petri nets support true concurrency and can be used to specify some of our clock relations. However it is not possible to force two separate transitions to fire “at the same time”, *i.e.*, to express coincidence. Thus, we use Merlin’s extension of Petri nets [9] that associates a time interval (two times a and b , with $0 \leq a \leq b$ and b possibly unbounded) with each transition: Time Petri nets. Times a and b , for transition t , are relative to the moment θ at which the transition was last enabled. t must not fire before time $\theta + a$ and must fire before or at time $\theta + b$ unless it is disabled before then by the firing of another transition. Even with this extension, the specification of CCSL constraints is far from straightforward, as this paper should show.

In our representation, each MARTE discrete-time pure clock $c = \langle \mathcal{I}_c, \prec_c \rangle$ is represented as a single transition c_t (called *clock transition*) of a Time Petri net. Instants of a clock are *firings* of the related transition. We also associate a place c_p (called *clock place*) with each clock, this place accumulates one token at each occurrence of the clock and thus represents the actual *local time* of the clock, its index. For a given initial marking and for a given firing sequence, there is an injective function $firingTime : CT \times \mathbb{N}^* \rightarrow \mathbb{N}$, where CT is the set of clock transitions. $firingTime(c_t, i)$ is the time at which, the clock transition c_t fires for the i^{th} time in the firing sequence. We consider a Time Petri net as equivalent to a CCSL clock constraint, iif for all possible firing sequences and all clock transitions (other transitions do not matter), $firingTime$ preserves the order :

$(\forall c1, c2 \in C)(\forall k1, k2 \in \mathbb{N}^*)$

$$((c1[k1] \preceq c2[k2]) \implies (firingTime(c1_t, k1) \leq firingTime(c2_t, k2)),$$

where $c1_t$ (resp. $c2_t$) is the clock transition associated with clock $c1$ (resp. $c2$). Note that, even though Time Petri nets can handle continuous time, we restrict our comparison to discrete-time clocks and therefore we consider the transition firing time as a natural number ($\in \mathbb{N}$).

3 Clock relation alternatesWith

The relation `alternatesWith` represents an asynchronous communication.

$A \sqsupseteq B$ means that each occurrence of A is followed by an occurrence of B before any other occurrence of A . The *weak form* of this relation allows the i^{th} occurrence of B to be simultaneous with the i^{th} occurrence of A (not strictly future), whereas the *strict form* requires A and B to be disjoint. Let A be the sender and B the receiver. The data is received after having been sent. No other communication can start before the previous one completes. The *weak form* allows the sender to receive the data synchronously with the emission, but do not force the synchronization. The *strict form* is used to forbid a synchronous communication.

Figure 1 illustrates the relation `strictly alternatesWith` and its only possible behavior when ignoring instants where neither A nor B are present (such instants are called *empty* instants).

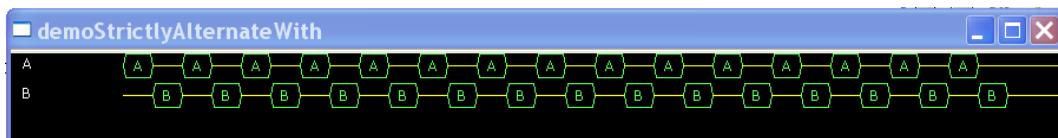

Figure 1: A strictly alternatesWith B

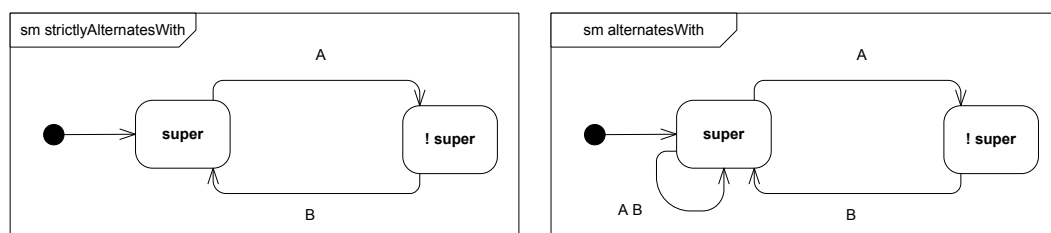

Figure 2: Behavior of clock relations (strictly) alternatesWith

In practice, there can be (infinitely) many empty instants between any occurrences of A and B and not necessarily as many between two successive occurrences of A or B .

Figure 2 shows the equivalent UML StateMachine. This is very similar to the covering step graph of the Time Petri net. Simultaneous events must appear on the same transition. Two different transitions denote independent events. The state machine only shows authorized events. There is no outgoing transition from state *super* with a label B . This does not mean that an event B occurring in this state would be lost but rather that the clock constraint makes it impossible for the event B to occur in this state. If, because of other clock constraints, this condition cannot be enforced, then the specification is rejected. In Signal, the program is rejected at compilation time. In Time Petri net, a violation of constraints results in clock transitions being dead.

3.1 Mathematical definition

Let A and B be two discrete-time clocks.

$$A \text{ strictly alternatesWith } B \iff (\forall k \in \mathbb{N}^*)(A[k] \prec B[k] \prec A[k+1])$$

$$A \text{ alternatesWith } B \iff (\forall k \in \mathbb{N}^*)(A[k] \preceq B[k] \prec A[k+1])$$

Note that the weak form of this clock relation can cause infinitely many different behaviors even if we ignore empty instants. $B[k]$ precedes $A[k+1]$ but can either be synchronous with $A[k]$ ($A[k] \equiv B[k]$) or strictly follow it ($A[k] \prec B[k]$). Those are the only two possible

situations that matters. When they are disjoint and when no other clocks are involved, the distance between two instants is not relevant.

3.2 Signal equivalent

When two clocks strictly alternate, there is a super clock, more frequent than both A and B (the relation is *endochronous*). To implement such a relation in **Signal**, one just need to build explicitly the common super clock. For instance, one can create a local *boolean* signal *super* that alternatively takes the value *true* and *false*, starting with *true*. A is synchronous with *super* when *super* is *true* and B is synchronous with *super* when *super* is *false*.

```
process strictlyAlternatesWith = ( ? event A,B )
  (| super := not (super$ init false)
   | A ^= when super
   | B ^= when not super
  |) where boolean super end;
```

The weak form is a bit different because either A and B occurs simultaneously, or A occurs alone and B should occur alone in the future. Not that B cannot occur alone when *super* is *true*. This is enforced in **Signal** by the relation $A \hat{=} \text{when } super$, when A must occur if (and only if) *super* is *true*, either alone or together with B .

```
process alternatesWith = ( ? event A,B )
  (| nextsuper ^= super ^= A^+ B
   | nextsuper := false when not B default true
   | super := nextsuper $ init true
   | A ^= when super
   | B ^> when not super
  |) where boolean super,nextsuper end;
```

3.3 Time Petri Net equivalent

Figure 3 gives Time Petri nets equivalent to both the strict (lefthand side) and the weak (righthand side) form of the clock relation *alternatesWith*. They only differ by the time interval on transition B . The weak form allows the transition B to fire either simultaneously or stricly after the firing of transition A .

4 Clock relation isPeriodicOn

The relation *isPeriodicOn* builds a periodic clock with respect to a *parent* clock for a given period. Note, that the clocks need not be chronometric. Optionnally, an offset may be specified when the periodic behavior only starts after a given number of occurrences of the parent clock.

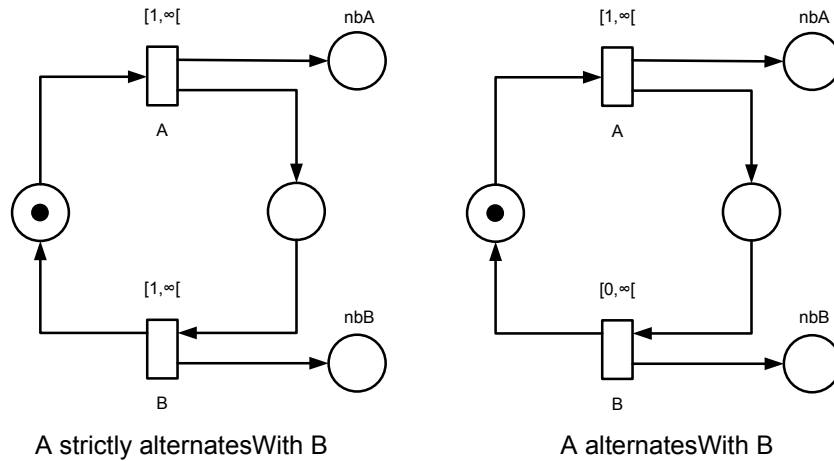

Figure 3: Relation alternatesWith (Time Petri net version)

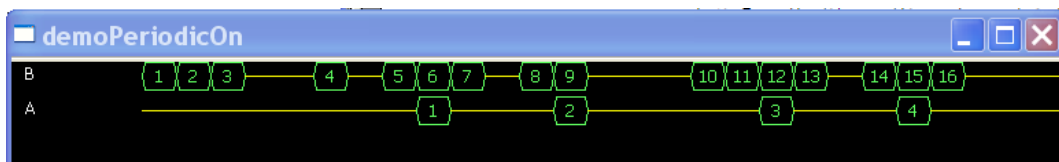

Figure 4: A isPeriodicOn B period=3 offset=5

A isPeriodicOn B period = P offset = δ is equivalent to a synchronous filtering starting from the δ^{th} occurrence of B where A occurs every P^{th} occurrence of B . A more general clock relation (`filteredBy`) has been defined in MARTE to filter a clock and build a less frequent clock by selecting some instants. Using the clock relation `filteredBy` (symbolically represented by \blacktriangledown) the relation `isPeriodicOn` can be written $A = B \blacktriangledown O^\delta \bullet (1 \bullet O^{P-1})$. When $\delta = 0$ and $P = 1$, A and B are synchronous.

Figure 4 gives one possible execution where A isPeriodicOn B period = 3 offset = 5. Signals A and B are counting their own occurrences. A always first occurs simultaneously with the 6th occurrence of B , whenever it is.

4.1 Mathematical definition

Let A and B be two discrete-time clocks.

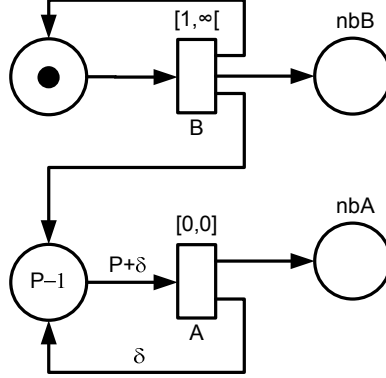
Figure 5: A isPeriodicOn B period= P offset= δ (Time Petri net version)

A isPeriodicOn B period = P offset = δ
 \iff
 $(\forall k \in \mathbb{N}^*)(A[k] \equiv B[(k-1) * P + \delta + 1])$

4.2 Signal equivalent

The implementation in Signal is straightforward since MARTE `filteredBy` relation is very close to the operator `when`. And the periodic case is one simple application.

```
process isPeriodicOn = { integer offset, period } ( ? event A, B )
  ( | nb ^= B
    | zi := nb$
    | nb := ((zi + 1) when zi/=(period-1)) default 0
    | ^A ^= when zi=0
    |) where integer zi init -offset, nb end;
```

4.3 Time Petri Net equivalent

Figure 5 gives Time Petri net equivalent to the clock relation `isPeriodicOn`. Transition B must fire $\delta + 1$ times before anything can happen to transition A . Then every P^{th} firing of transition B , A must fire synchronously because the time interval is $[0,0]$. Using a time interval $[0,0]$ is very handy to represent instantaneous reactions. However, when several such transitions are enabled at the same time, the use of priorities may become necessary.

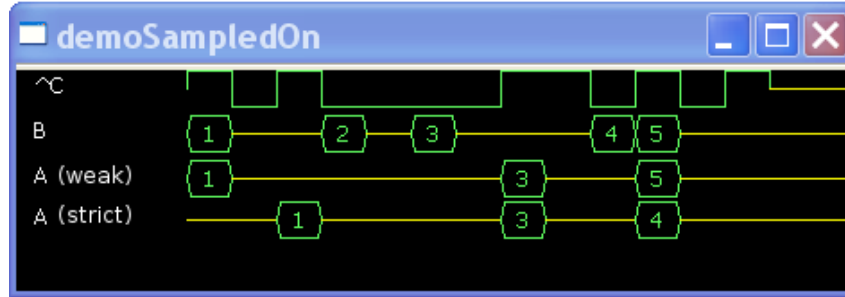
Figure 6: $A=B$ sampledOn C

5 Clock relation sampledOn

The relation `sampledOn` represents sampling, it can be used to model time-triggered communications or for synchronizing asynchronous inputs. $A = B \downarrow C$ defines a subclock of C (less frequent than C in Signal terminology) that occurs only after an occurrence of B . The *strict form* of `sampledOn` does not sample an occurrence of B when it is synchronous with an occurrence of C .

Figure 6 shows one possible scenario involving the clock relation `sampledOn` with both forms weak and strict. Signal B counts its occurrences and signal A contains the value actually sampled from B .

With both forms the first sample has the value 1. However, with the weak form the first sample occurs on the first occurrence of C whereas it occurs on the second occurrence of C with the strict form. The second sample has the value 3 and the input 2 has been lost in both cases. The third sample occurs at the same time, whatever the form, but does not carry the same value in both cases.

5.1 Mathematical definition

Let A, B and C be three discrete-time clocks.

$A = B$ strictly sampledOn C

$$\iff (\forall a \in \mathbb{N}^*)(\exists b, c \in \mathbb{N}^*)((A[a] \equiv C[c]) \wedge (C[c-1] \preceq B[b] \prec C[c]))$$

$A = B$ sampledOn C ($A = B \downarrow C$)

$$\iff (\forall a \in \mathbb{N}^*)(\exists b, c \in \mathbb{N}^*)((A[a] \equiv C[c]) \wedge (C[c-1] \prec B[b] \preceq C[c]))$$

5.2 Signal equivalent

As always, the *weak form* of clock relations is more difficult to implement since it implies instantaneous reactions. Synchronous languages are very well-suited to describe such behaviours. The following Signal implementations count the number of occurrences of *inp* between two successive occurrences of *clk*. A sampling occurs where there is at least one occurrence of *inp* ($zc/=0$).

```
process strictlySampled0n = (? event inp, clk ! event outp )
  (| c ^= zc ^= inp ^+ clk
   | zc := c$ init 0
   | c := 1 when clk when inp default 0 when clk default zc+1 when inp
   | outp := when zc/=0 when clk
   |) where integer c, zc end;
```

The weak form is similar but the input event (*inp*) can occur simultaneously with the sampling clock (*clk*).

```
process sampled0n = ( ? event inp, clk ! event outp )
  (| c ^= inp ^+ clk
   | zzc := 1 when ^inp default zc
   | zc := c$ init 0
   | c := 0 when clk default zc+1
   | outp := when zzc/=0 when clk
   |) where integer c,zc,zzc end;
```

5.3 Time Petri Net equivalent

Figure 7 shows the Time Petri net implementation of the strict form. This implementation requires priority transitions (dashed/blue arcs between transitions). The arc source has a higher priority than the target. When two transitions are enabled, the transition with highest priority must fire first possibly preventing another transition from firing. When the order does not matter, the transition are said to be independent.

Transition *pB* purges tokens produced by *B* when there are multiple occurrences of *B* between two successive occurrences of *C*. Transition *pC* purges tokens produced by *C* when they are not immediately consumed by transition *A*. Transition *pC* must have a higher priority than transition *A*, an old clock concurrence is always purged when possible and not used to sample any input.

The weak form is not easy to implement since it involves instantaneous reactions that leads to races so that the order of firing becomes important. Still, the implementation is possible if we assume that input clock transitions (*B* and *C* here) always have a higher priority than other transitions. Because of the lack of room and because it is not possible to formally take this consideration within the model we do not present the implementation here. In a general way, weak forms that involves instantaneous reactions are better represented by synchronous languages.

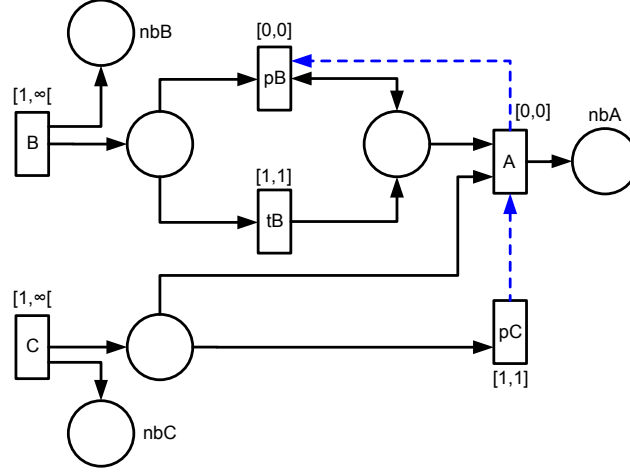
Figure 7: $A=B$ strictly sampledOn C (Time Petri net version)

6 Clock relation delayedFor

The relation `delayedFor` models a watchdog. A clock `start` triggers a timer that counts according to a reference clock. A timeout elapsed after `delay` occurrences of the reference clock. If the clock `start` occurs again before the time out, then the timer is reinitialized. This is a polychronous operator as the clocks `start` and `timeout` are not synchronous. Note that even though the clock `timeout` is a subclock of the reference clock, it is not required for the clock `start` to be a subclock as well.

6.1 Mathematical definition

Let A, B and C be three discrete-time clocks and $\delta \in \mathbb{N}^*$

$A = B \text{ delayedFor } \delta \text{ on } C$

\iff

$(\forall a \in \mathbb{N}^*)(\exists c, b \in \mathbb{N}^*, c > \delta)((A[a] \equiv C[c]) \wedge (C[c - \delta - 1] \prec B[b] \preceq C[c - \delta]))$

6.2 Signal equivalent

The clock relation `delayedFor` is very different from the `Signal` operator `delay` (\$) since in `Signal` the operator `delay` is monochronous. In the implementation below, signal c counts for the occurrences of clk and is reset when $start$ occurs. `timeout` occurs when $c = delay$.

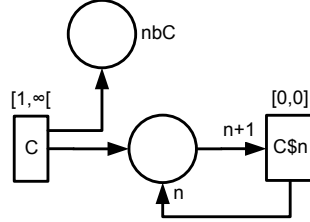
Figure 8: Signal delay: $c\$n$

```

process delayedFor = { integer delay } ( ? event start, clk ! event timeout )
  ( | c ^= start ^+ clk
    | zc := c$ init 0
    | c := 0 when start default zc+1 when clk
    | timeout := when c=delay
  |) where integer c, zc end;

```

6.3 Time Petri net equivalent

Signal operator delay (\$) has a very simple equivalent in Time Petri net (Figure 8). However, the MARTE operator `delayedFor` is much more complex and requires the use of inhibitors. In Petri nets, inhibitors are arcs from a place to a transition with a circle as an arrowhead. Contrary to the normal semantics of arcs, the inhibited transition becomes fireable only when no token are available in the place.

Figure 9 shows the MARTE clock relation `delayedFor` in Time Petri net. As for the relation `sampledOn`, the transitions `pS` and `tS` purge tokens produced by `start` when more than one token are available. Remember that `start` and `clk` are not necessarily synchronous, so `start` needs to be synchronized.

Transition `pC` purges the tokens produced by `clk` when `start` occurs. The counting should only start on `start`. The transition `inC` stops the purge when no tokens from `clk` are available.

7 Illustration: Easter days

7.1 Specification

To illustrate the integration of CCSL clock constraints with UML models we re-use an example that has initially been presented in [6]. This example models the canonical rule to process Easter days: “Easter Day is the first Sunday after the 14th day of the lunar month that falls on or after March 21st (nominally the day of the vernal equinox)”.

Some requirements refer to events (Sunday, vernal equinox); others involve “temporal” operators (after, on or after). Some events need additional explanations. The *nominal full*

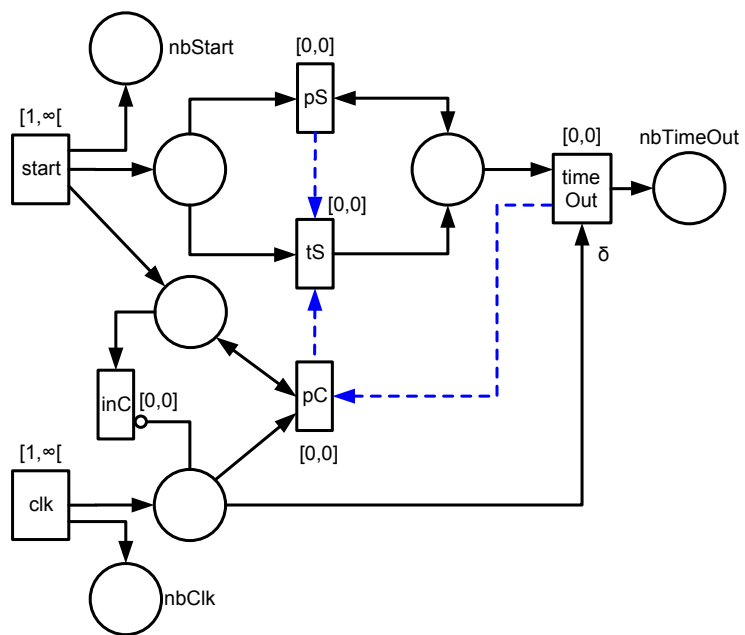
Figure 9: $\text{timeOut} = \text{start}$ delayedFor δ on clk

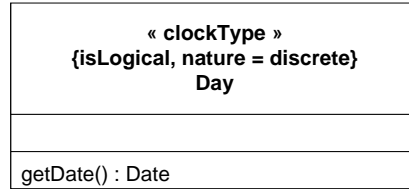

Figure 10: Clock type Day in MARTE

moon, refers to an “ecclesiastic” full moon distinct from the astronomic one. It occurs exactly 14 days after the new moon, *i.e.*, it is the 14th day of the lunar month.

Similarly, the “ecclesiastic” vernal equinox always occurs on March 21st, while the date of the actual spring equinox is the 21st or the 22nd.

7.2 MARTE implementation

Before modeling clock constraints, we need to model clocks. MARTE defines two stereotypes, `ClockType` and `Clock`. Clock types gather common informations between similar clocks. The stereotype `ClockType` extends the UML metaclass `Class` whereas the stereotype `Clock` extends the metaclass `InstanceSpecification`. The clock type we need here will represent days (see Figure 10), it is a discrete clock type. An operation `getDate()` gives the actual date of the day. A third stereotype, `ClockConstraint`, extending the metaclass `Constraint` stands for CCSL clock constraints. The specification language of such constraints has to be CCSL.

However, a graphical form of the language would be more appropriate to integrate with UML models. We have defined a non-normative representation of clock constraints. This representation is introduced here for the first time. Clock constraints are represented as stereotyped dependencies. The stereotype depends on the kind of clock constraints.

Figure 11 shows the specification of Easter applying constraints. Note, that the stereotypes that represent the clock constraints are not normative, as only the time structure itself is normative to let tool vendors make their own graphical choices.

In this specification, the time starts on Saturday, March 1st 2008. This explains the periodic pattern between *sundays* and *calendarDays*. There is one Sunday every *seventh* day and the first Sunday is on March, 2nd. Moreover, to resolve the relation *isFinerThan* from *newMoons* to *calendarDays* we must know the Ephemeris, starting of March 1st. The pattern of New Moon occurrences is not completely regular or periodic and cannot be predicted with a simple computation, it has to be given as an input.

7.3 Signal implementation

A full implementation of the Easter specification has been performed in Signal. This implementation has successfully predicted the date of Easter 2008 and 2009. This success comforts us in the equivalence of our representation. Even though the date of Easter is known, the

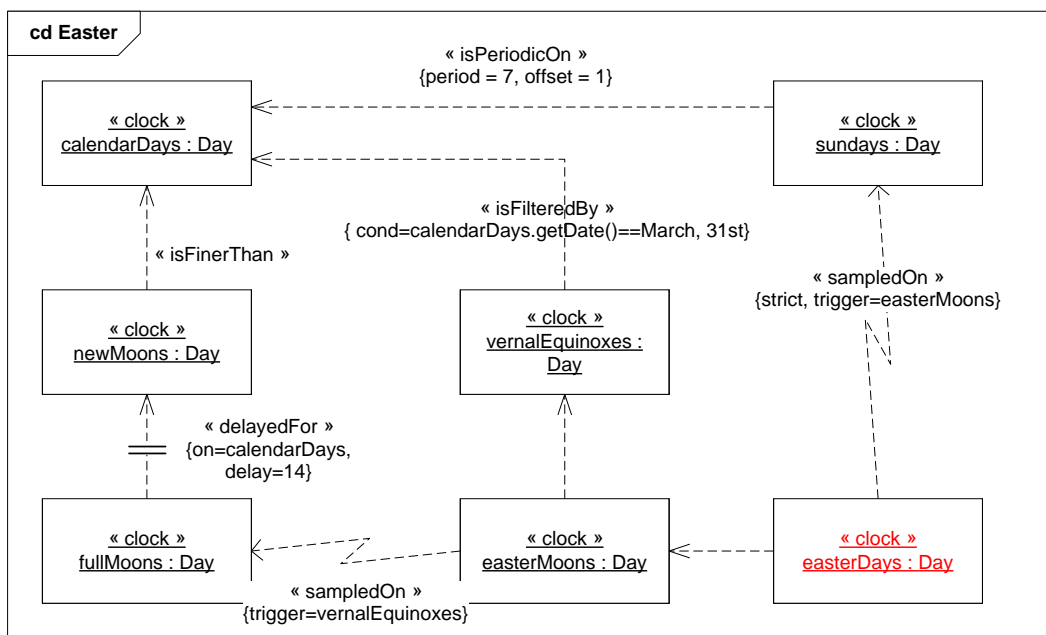

Figure 11: Easter specification with CCSL

specification itself contains several interesting constraints not easy to specify with usual languages.

The formal proof of the equivalence has not yet been performed as the methodology to establish the proof is not clear. Both Signal and Time Petri nets are amenable to formal verifications. We have been using Polychrony [10] for the implementation in Signal and TiNA [11] for the implementation in Time Petri nets. Both these environments come with facilities to perform model-checking of properties expressed in a temporal logic. Nevertheless, to establish the equivalence between the properties and our mathematical specification still requires some additional work. One hint would be to compare Mazurkiewicz's traces [12] for both our specification and the Time Petri net but this has not been done yet.

In Signal, the civilian and the lunar months are given as inputs since they cannot be deduced by a simple computation. However, clocks are neither inputs nor outputs but are internal constructs to help constraining a system behavior.

```

process easter =
  ( ? integer month, lunarMonth
    ! integer monthName, newMoon, vernalEquinox, sundays;
      event fullMoon, easterMoon; integer easter )
  (| month08 := month

% oversample month to get days %
  | days2008 := days(month08)

% oversample lunarMonth to get lunar days %
  | lunarDays := days(lunarMonth)
  | lunarDays ^= days2008

% process new moon from input newMoon %
  | newMoon := days2008 when lunarDays = 1

% process full moon = fourteen days later than new moon %
  | fullMoon := delayed{14}(~newMoon, ^days2008)

% process days of the week days in [0,6], first Day of March, 2008 is saturday=6%
  | weekDays2008 ^= days2008
  | weekDays2008 := cyclingCounter{6,1,6}()

% process month names, starting from March, 3=2+1 %
  | monthName ^= days2008
  | monthName := (pre_monthName+1 when pre_monthName<12 default 1) when ^month
                  default pre_monthName when ^days2008
  | pre_monthName := monthName$ init 2

```

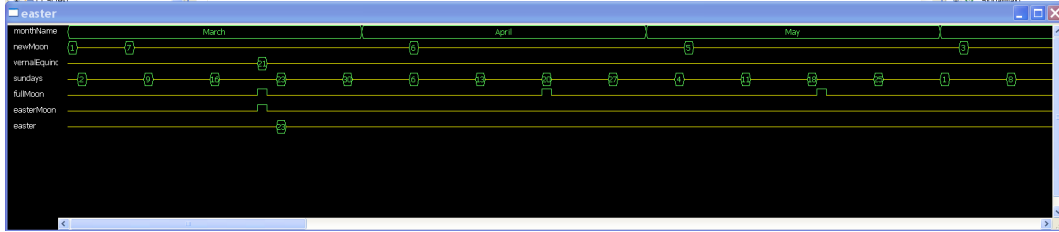

Figure 12: Easter 2008

```

% process vernal equinox: March, 21st%
  | vernalEquinox := days2008 when days2008=21 and monthName=3

% process sundays (=0) knowing than March, 1st 2008 is Saturday (6) %
  | sundays := days2008 when weekDays2008=0

% Easter moon is the first full moon following or equal to the vernal equinox %
  | easterMoon := sampledOn{ }(^vernalEquinox, ^fullMoon)

% Easter is the Sunday (stricly) following Easter moon %
  | C_easter := strictlySampledOn{ }(easterMoon, ^sundays)
  | easter := days2008 when C_easter

|) where
  integer month08;
  integer days2008, weekDays2008, pre_monthName;
  integer lunarDays;
  event C_sundays, C_easter;
  use ccs1;
  use counting;
  use calendar
  end
% easter %;

```

Figure 12 shows the result of this Signal process starting on March 2008. We see that Easter occurs on March, 23rd.

Figure 13 shows Easter will occur next year on April, 12th 2009.

8 Conclusion

This paper presents several possible equivalent specifications for MARTE clock constraints. Having only a pure mathematical definition as in [6] is not pragmatic since one objective

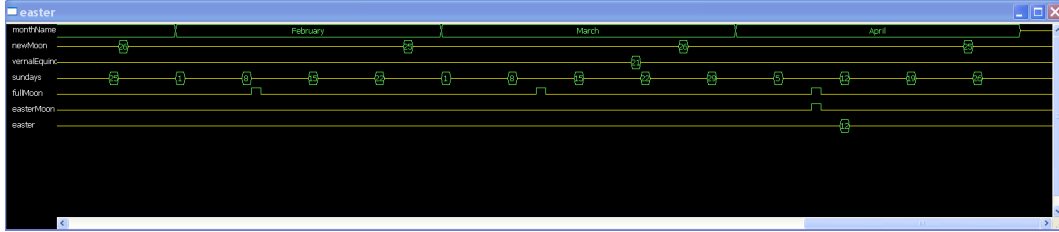

Figure 13: Easter 2009

of MARTE Time Model is to provide the support for building executable models for real-time and embedded systems. The transformation of a pure mathematical specification and a simulator is not easy to perform. However, there are several formal models available in the community that comes together with analysis and simulation tools. Signal and Time Petri nets are examples. An OMG Specification is not the right framework to select tools and textual languages. This paper intent is to show that the gap between MARTE-compliant UML models and some existing tools can be filled. To garanty, a full compliance, we still have to prove formally, the equivalence of the proposed Time Petri nets and Signal programs.

The second contribution of this paper is to show the non-normative graphical representation of clock constraints as an instance diagram. Even though, constraints are supposed to apply to a behaviour, it is not surprising that we used a structural diagram to represent the constraints. Indeed, MARTE specification introduces a Time Structure. This Time Structure induces a partial order on instants, this partial order is equivalent to the set of all possible execution traces.

References

- [1] Object Management Group: Unified Modeling Language, Superstructure (November 2007) Version 2.1.2 formal/2007-11-02.
- [2] Object Management Group: UML Profile for MARTE, beta 1. (August 2007) OMG document number: ptc/07-08-04.
- [3] Lee, E.A., Sangiovanni-Vincentelli, A.L.: A framework for comparing models of computation. *IEEE Transactions on Computer-Aided Design of Integrated Circuits and Systems* **17**(12) (December 1998) 1217–1229
- [4] Benveniste, Caspi, Edwards, Hallbwachs, Guernic, L., de Simone: The synchronous languages twelve years later. *Proceedings of the IEEE* **91**(1) (2003)
- [5] André, C., Mallet, F., de Simone, R.: Modeling time(s). In Engels, G., Opdyke, B., Schmidt, D.C., Weil, F., eds.: *MoDELS*. Volume 4735 of *Lecture Notes in Computer Science*, Springer (2007) 559–573

- [6] André, C., Mallet, F.: Clock constraints in UML/MARTE. Research Report RR-6540, INRIA (2008)
- [7] Petri, C.: Concurrency theory. In Brauer, W., Reisig, W., Rozenberg, G., eds.: Petri Nets: Central Models and their properties. Volume 254 of Lecture Notes in Computer Science. Springer-Verlag (1987) 4–24
- [8] Benveniste, A., Guernic, P.L., Jacquemot, C.: Synchronous programming with events and relations: the signal language and its semantics. *Sci. Comput. Program.* **16**(2) (1991) 103–149
- [9] Merlin, P.: A Study of the Recoverability of Computer Systems. PhD, University of California, Irvine (1974)
- [10] Guernic, P.L., Talpin, J.P., Lann, J.C.L.: Polychrony for system design. *Journal of Circuits, Systems, and Computers* **12**(3) (2003) 261–304
- [11] Berthomieu, B., Vernadat, F.: Time petri nets analysis with TINA. In: QEST, IEEE Computer Society (2006) 123–124
- [12] Mazurkiewicz, A.W.: Trace theory. In Brauer, W., Reisig, W., Rozenberg, G., eds.: Advances in Petri Nets. Volume 255 of Lecture Notes in Computer Science., Springer (1986) 279–324

Contents

1	Introduction	3
2	Formalisms under consideration	4
2.1	MARTE Time Structure	4
2.2	Signal	4
2.3	Time Petri net	4
3	Clock relation alternatesWith	5
3.1	Mathematical definition	6
3.2	Signal equivalent	7
3.3	Time Petri Net equivalent	7
4	Clock relation isPeriodicOn	7
4.1	Mathematical definition	8
4.2	Signal equivalent	9
4.3	Time Petri Net equivalent	9
5	Clock relation sampledOn	10
5.1	Mathematical definition	10
5.2	Signal equivalent	11
5.3	Time Petri Net equivalent	11
6	Clock relation delayedFor	12
6.1	Mathematical definition	12
6.2	Signal equivalent	12
6.3	Time Petri net equivalent	13
7	Illustration: Easter days	13
7.1	Specification	13
7.2	MARTE implementation	15
7.3	Signal implementation	15
8	Conclusion	18



Unité de recherche INRIA Sophia Antipolis
2004, route des Lucioles - BP 93 - 06902 Sophia Antipolis Cedex (France)

Unité de recherche INRIA Futurs : Parc Club Orsay Université - ZAC des Vignes
4, rue Jacques Monod - 91893 ORSAY Cedex (France)

Unité de recherche INRIA Lorraine : LORIA, Technopôle de Nancy-Brabois - Campus scientifique
615, rue du Jardin Botanique - BP 101 - 54602 Villers-lès-Nancy Cedex (France)

Unité de recherche INRIA Rennes : IRISA, Campus universitaire de Beaulieu - 35042 Rennes Cedex (France)

Unité de recherche INRIA Rhône-Alpes : 655, avenue de l'Europe - 38334 Montbonnot Saint-Ismier (France)

Unité de recherche INRIA Rocquencourt : Domaine de Voluceau - Rocquencourt - BP 105 - 78153 Le Chesnay Cedex (France)

Éditeur

INRIA - Domaine de Voluceau - Rocquencourt, BP 105 - 78153 Le Chesnay Cedex (France)

<http://www.inria.fr>

ISSN 0249-6399