



HAL
open science

A Technical Review of Real-time QoS Protocols in Wireless Sensor Networks

Yanjun Li, Chung Shue Chen, Ye-Qiong Song

► **To cite this version:**

Yanjun Li, Chung Shue Chen, Ye-Qiong Song. A Technical Review of Real-time QoS Protocols in Wireless Sensor Networks. [Research Report] RR-6369, INRIA. 2007, pp.27. inria-00192615

HAL Id: inria-00192615

<https://inria.hal.science/inria-00192615v1>

Submitted on 28 Nov 2007

HAL is a multi-disciplinary open access archive for the deposit and dissemination of scientific research documents, whether they are published or not. The documents may come from teaching and research institutions in France or abroad, or from public or private research centers.

L'archive ouverte pluridisciplinaire **HAL**, est destinée au dépôt et à la diffusion de documents scientifiques de niveau recherche, publiés ou non, émanant des établissements d'enseignement et de recherche français ou étrangers, des laboratoires publics ou privés.



INSTITUT NATIONAL DE RECHERCHE EN INFORMATIQUE ET EN AUTOMATIQUE

*A Technical Review of Real-Time QoS Protocols for
Wireless Sensor Networks*

Yanjun Li — Chung Shue Chen — Ye Qiong Song

N° 6369

November 2007

Thème COM

*R*apport
de recherche



A Technical Review of Real-Time QoS Protocols for Wireless Sensor Networks

Yanjun Li , Chung Shue Chen , Ye Qiong Song

Thème COM — Systèmes communicants
Projets TRIO

Rapport de recherche n° 6369 — November 2007 — 27 pages

Abstract: Real-time wireless sensor networks become more and more important in emerging new applications as message delivery timeliness is highly concerned. However, supporting real-time QoS in sensor networks has faced many challenges due to their wireless nature, limited resource, dynamic network topology, and the demand of distributed architecture. There are tradeoffs between different application requirements including energy efficiency and delay performance. This paper studies the state of the art of current real-time solutions including MAC protocols, routing protocols, data aggregation strategies, and cross-layer designs. Some research challenges and design favors are also identified. The discussion may offer a reference for future investigations.

Key-words: real-time, quality of service, wireless sensor networks, medium access control, routing protocol, data aggregation, cross-layer design.

Un état de l'art sur la qualité de service temps réel des réseaux de capteurs sans fil

Résumé : Le déploiement des applications temps réel émergentes sur des réseaux de capteurs sans fil exige la garantie en terme de la qualité de service. La fourniture de la qualité de service temps réel dans un réseau de capteurs sans fil pose des problèmes de recherche non triviaux à cause de la nature de la transmission sans fil, de la limitation de ressources, du changement dynamique de la topologie et le besoin d'une architecture distribuée. En particulier nous devons trouver un bon compromis entre des différentes exigences telles que la faible consommation de l'énergie et les performances temporelles. Ce papier fait une analyse technique sur l'état de l'art des solutions incluant les protocoles MAC et de routage, les stratégies de l'agrégation de données et les approches de conception inter-couches. Nous identifions les défis et les approches courantes. Cette analyse devrait fournir une référence de départ pour des investigations plus approfondies.

Mots-clés : temps réel, qualité de service, réseaux de capteurs sans fil, protocoles d'accès au médium, protocoles de routage, agrégation de données, conception inter-couches

1 Introduction

Wireless sensor networks (WSNs) are revolutionizing the way people interact with the physical world. A large volume of sensor nodes are deployed to collect data from the environment, perform local processing, and communicate their results either with a base station (BS) which people may access via Internet or directly with actuators which conduct actions in response. Although energy efficiency is usually the primary concern in WSNs, the requirement of low latency communication is getting more and more important in new applications. Out-of-date information will be irrelevant and may even lead to negative effects to the system monitoring and control.

Examples of real-time (RT) sensor applications can be found in many military or environmental surveillance systems [1]. The collected data must reach the control unit in a limited duration to ensure an effective RT tracking of the observed region. Otherwise, the object being tracked may no longer be in vicinity [2]. In medical applications [3], sensor devices are required to capture RT vital signs from patients; critical sensory data must be displayed at the doctor's control monitor in time so as to take prompt actions. Besides, RT sensor networks can also be used to improve the response time to disasters. A low-cost WSN is able to detect the initiation of wildfire and monitor its spread effectively based on temperature sensors [4]. Another example is the application in seismic monitoring [5], in which sensor nodes with accelerometers are installed in a building near the critical structural points to report the location and kinematics of damages during or after an earthquake for rapid, accurate structural health diagnosis.

In supporting delay constrained applications, a WSN can be modeled as a distributed RT system. However, it differs dramatically from the traditional RT systems due to its wireless nature, limited resources (processing ability, power supply and memory space), low node reliability and dynamic network topology [6]. Thus, a WSN is often less reliable and its performance is less predictable. Very little prior work can be applied directly. New designs are necessary for offering RT quality of service (QoS) in WSNs with guaranteed end-to-end delivery time, delay jitter and other QoS metrics. This refers to a new challenge for WSNs in the coming decade.

Without loss of generality, RT QoS guarantees can be categorized into two classes: hard real-time (HRT) and soft real-time (SRT). In HRT system, deterministic end-to-end delay bound should be supported. The arrival of a message after its deadline is considered as failure of the system. While in SRT system, a probabilistic guarantee is required and some lateness is tolerable. Hence, supporting RT QoS in WSNs means there should be either a deterministic or probabilistic end-to-end delay guarantee. Of course one should always bear in mind that providing HRT guarantee through a noisy radio channel is in general unfeasible because of the non-neglecting transmission error probability. In fact the transmission delay is often random due to the automatic retransmission mechanisms of the physical layer protocol. However, in the rest of this paper we still use the term HRT whenever the MAC and routing protocols provide deterministic behavior from pure mechanism point of view, this, although the resulting end-to-end delay can only be probabilistically bounded considering the random physical layer behavior. It should be noted that while considering RT support in WSNs,

energy efficiency should never be ignored. There is often a tradeoff between these two considerations.

From a layered view, the MAC should provide channel access delay (single-hop) guarantee, while in the network layer the routing protocol should bound the end-to-end (multi-hop) transmission time. One may also adopt a cross-layer design to have a joint optimization. Besides, a proper in-network data aggregation strategy could be a good complement to routing protocols in reducing data redundancy and alleviating network congestion. Note that middleware is embedded to bridge the gap between applications and lower layers so as to provide abstraction and mechanisms for efficient and adaptive coordination. Some informative discussions of the design issues for WSNs can be found in [7][8]. The detail will not be addressed here.

This paper aims to provide a survey on the state of the art of the real-time QoS protocols in WSNs. The remainder of the article is organized as follows. Section 2 provides a survey on related MAC, routing, data aggregation strategies and cross-layer designs. The challenges of Real-time QoS support for WSNs and some potential research directions are discussed in Section 3. Finally, in Section 4, we conclude the report.

2 Current Solutions for RT-WSNs

In the following, some related MAC, routing protocols, data aggregation strategies, and cross-layer designs are discussed respectively. The report focuses on their RT QoS supports.

2.1 RT MAC Solutions

In WSNs, MAC plays a key role in determining the channel access delay, utilization and energy consumption. Existing MAC designs in WSNs can be classified into three categories: contention-based, contention-free and hybrid schemes. In contention-based MAC, due to the distributed and random backoff nature, it is difficult to provide a deterministic channel access guarantee. Packet collision is generally inevitable but reducible [9]. Nevertheless, a well-defined statistical bound is always required in offering SRT guarantee. On the other hand, contention-free MAC can be deployed with dedicated channel allocation. In TDMA-based MAC, a bounded and predictable medium access delay can be determined via time slot scheduling. However, a centralized coordinator is often required and since the traffic has to wait to transmit each time until the next round of assigned time slots, the delay incurred could not be neglected. For the completeness, the discussion of MAC here is not limited to those which can provide deterministic or probabilistic guarantee but also some commonly used MAC protocols, for example, S-MAC [9], T-MAC [10] and B-MAC [11], which reduce delay in a best effort approach.

S-MAC (Sensor-MAC) is a CSMA/CA based protocol. It adopts virtual clusters and requires only loose synchronization between them. Figure 1 shows the timing relationship between one receiver and several senders. Schedule information is exchanged by periodic SYNC packets in neighborhood during synchronization period. Collision avoidance is achieved by

carrier sensing (CS), as indicated in Figure 1. Message transfer is conducted by using traditional RTS/CTS/DATA/ACK procedure so as to limit collisions caused by the hidden node problem. To save energy consumption, S-MAC uses periodic listening and sleeping. It also includes the concept of message passing, in which long messages are divided into frames and sent in bursts. In order to reduce latency due to the low-duty-cycle operation, adaptive listening is employed. A node overhearing its neighbor's transmission will wake up for a short time at the end of the transmission if it is a next-hop node to which the transmitter can pass data immediately. However, it should be noted that adaptive listening will incur overhearing or idle listening if the packet is not destined to the listening node.

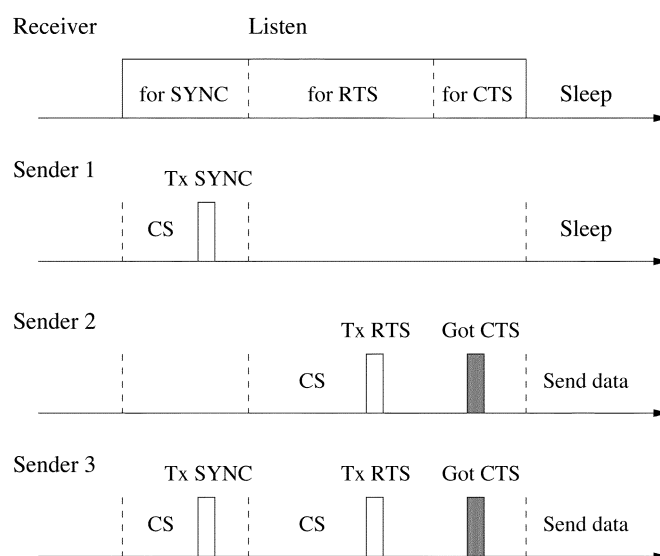

Figure 1: S-MAC messaging scenario [9]

T-MAC (Timeout-MAC) improves the energy efficiency of S-MAC in networks where message rates vary. Instead of using a fixed-length active period as S-MAC, T-MAC uses a time-out mechanism to dynamically determine the end of the active period as described in Figure 2. The time-out value, denoted by TA, is set to span a small contention period and an RTS/CTS exchange. If a node does not detect any activity (an incoming message or a collision) within interval TA, it can safely assume that no neighbor wants to communicate with and goes to sleep. On the other hand, if the node engages or overhears a communication, it starts a new time-out after that communication is finished. By adaptively ending the active period, T-MAC nodes may save energy by lowering the amount of time spent in idle listening and also adapt to traffic changes. To improve latency, T-MAC introduces a future request to send message (FRTS) such that sensor nodes will use it to inform the next hop whether there is a future message to be transmitted. Extensive simulation shows T-MAC

in combination with low-power listening saves more energy than S-MAC. However, it is not able to handle the same peak loads as CSMA/CA and S-MAC [12].

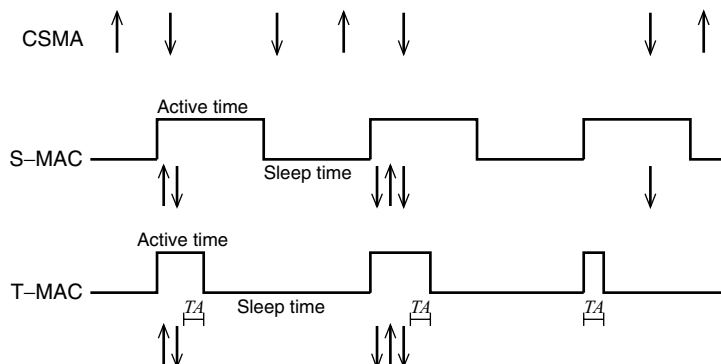

Figure 2: Comparison of S-MAC and T-MAC duty cycles : the arrows indicate transmitted and received messages [11]

B-MAC (Berkeley-MAC) has higher throughput and better energy efficiency than S-MAC and T-MAC. In B-MAC, sensor nodes operate on independent schedules and very long preambles are used for message transmission. Figure 3 shows a message transfer in B-MAC. The source node transmits a preamble long enough such that the destination, which periodically senses the channel, has enough time to wake up and sense activity. Sensor nodes that sense activity on the channel remain awake to receive the message following the preamble or return to sleep if they do not detect activity. Before transmitting, sensor nodes delay a random time to prevent synchronization, and sense the channel to prevent corrupting an ongoing transmission. Since B-MAC relies on accurately determining the channel status, it defines a filtering mechanism that increases the reliability of channel assessment. Additionally, B-MAC provides a great deal of flexibility through a protocol interface that allows the sensor node to change operating variables in the protocol, such as delay and backoff values. B-MAC provides no solution for traditional wireless problems, such as the hidden terminal problem. Upper protocols must provide the functionality or accept the performance overhead associated with the losses. Sensor nodes using B-MAC have instant access to the network once deployed or moved since the protocol requires no setup or prior communication. Furthermore, B-MAC does not have to defer messages waiting for a valid time to access the channel. As long as a sensor node does not corrupt an ongoing reception, a sensor node can begin transmitting a message immediately. The long preambles in B-MAC do introduce an additional latency, but end users can consider this in the sensor network design and sensor nodes may control it through the protocol interface. A shorter sleep time will yield a lower latency at an additional energy cost.

An implicit prioritized access protocol (I-EDF) [13] is designed especially for HRT-WSNs. A cellular backbone network is adopted and seven different frequency channels are used to

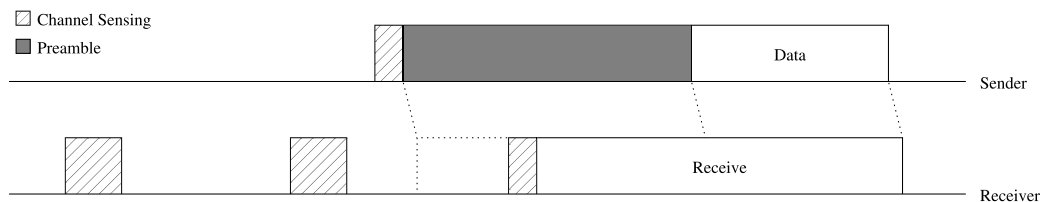

Figure 3: B-MAC data transfer [10]

avoid co-channel interference. A capable router node is required at the center of each cell and equipped with two transceivers for separate transmission and reception. Explicitly, it transmits inter-cell messages using one channel and receives inter-cell messages by another. In a cell, time is divided into frames and all nodes are frame synchronized and follow earliest deadline first (EDF) schedule for packet transmission to guarantee bounded delay. The key idea is to replicate the EDF schedule at each node thus they will know which one has the message with the shortest deadline and has the right to transmit next. Moreover, unused frames can be exploited using the FRAMe SHaring (FRASH) technique, the goal of which is to increase network utilization while preserving the hard message guarantee. Inter-cell communication is supported by a globally synchronized TDMA scheme and the messages are ordered by their earliest deadlines by the router node. During each inter-cell frame, each router transmits and receives inter-cell messages according to a predetermined direction as demonstrated in Figure 4. If the inter-cell communication mechanism is combined with a special routing protocol, end-to-end delay guarantee is given by summing the bounded delay at each router node in path along route. The mixed FDMA-TDMA scheme offers a collision-free solution. Simulations show that I-EDF can provide high throughput and low latency even in heavy loads. However, the system architecture and requirements appear impractical for conventional WSNs. Nodes are assumed synchronized. Routers need to be deployed specifically following the cellular structure, while topology knowledge is required.

Watteyne *et al.* [14] propose a dual-mode MAC protocol which supports HRT but with more relaxed assumption than I-EDF. The goal is to guarantee deterministic transmission time compatible to application deadline. A linear network is considered with identical nodes deployed roughly along a line. Two modes are provided: protected and unprotected modes. The key idea of the protocol is its back-off scheme. As all nodes are assumed to be separated by a distance at least $dist_{min}$, if all nodes willing to transmit after hearing a signaling message wait for a backoff time proportional to their distance to the sender, there will be no collision. The furthest node from the sender will transmit first. The dual-mode MAC starts in the unprotected mode, which tries to offer near optimal speed of message delivery toward the sink. This mode does not use the cell based organization. Collisions are possible, but they will trigger a switch of the network to the protected mode as soon as collision occurs. Protected mode guarantees collision-free functioning with bounded transmission times. It uses the cell based organization created during system initialization with a global

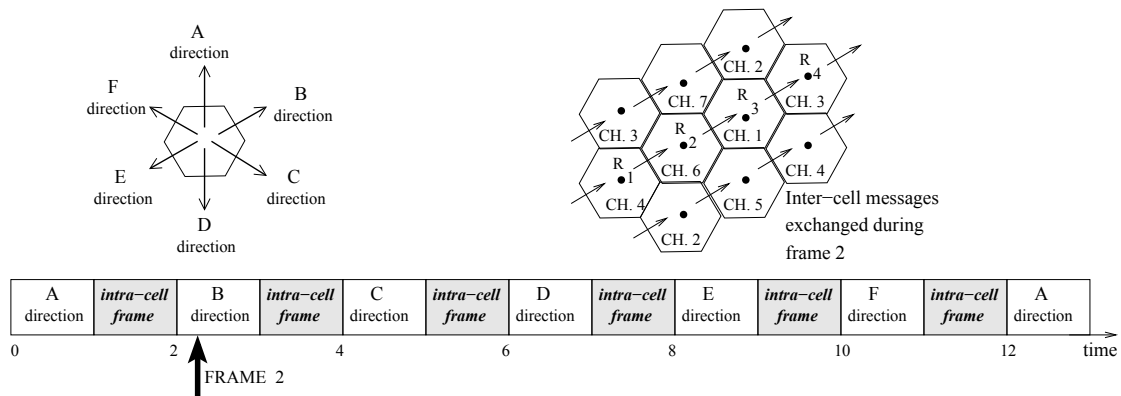

Figure 4: Example of inter-cell communication in I-EDF [13]

synchronization mechanism. Switching between these two modes, the protocol is able to provide worst case delay bound and also good mean performance especially when the load is low. Similar to I-EDF, the design has the following shortages: (i) energy efficiency is not considered, (ii) dedicated frequency channels are required for different cells, and (iii) a cellular network structure is needed in the protected mode. However, these mixed FDMA-TDMA schemes are promising in supporting HRT guarantees.

DMAC [15] is an energy efficient and low-latency MAC designed for unidirectional data gathering tree. Conventional MAC protocols that utilize active/sleep duty cycle often suffer from significant sleep delay since nodes involved in multi-hop data forwarding are not all notified of the ongoing data delivery. By properly offsetting the active/sleep schedule of nodes based on its depth in the data gathering tree, continuous packet forwarding is maintained while nodes on the multi-hop path are notified of the delivery. Figure 5 shows the data gathering tree and the staggered wake-up scheme. An interval is divided into receiving, sending, and sleep periods. The receiving and sending periods have the same length, μ , which is enough for one packet transmission and reception. Depending on the depth in the data gathering tree, d , the node skews its wake-up scheme a duration of $(d \times \mu)$ ahead from the schedule of the sink. Nodes with the same depth will have the same offset, and thus a synchronous schedule. To reduce collision, every node backs off for a backoff period plus a random time within a contention window at the beginning of the sending slot. When a node receives a packet, it waits for a short period then transmits the ACK packet to the sender. When a node has multiple packets to send at a sending slot, DMAC piggybacks a “*more data*” flag in the MAC header to indicate the request for additional active periods. Furthermore, a data prediction mechanism and the use of explicit control packet are proposed in order to alleviate the problem related to channel contention and collisions. Simulations show that DMAC can achieve both energy saving and latency reduction.

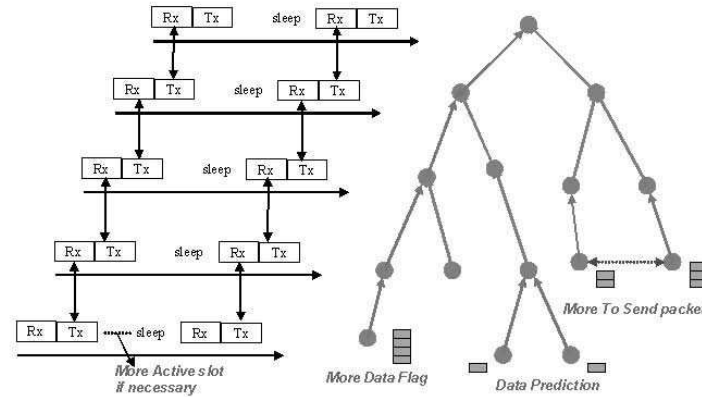

Figure 5: DMAC in data gathering tree [15]

DB-MAC [16] is contention-based MAC protocol designed for delay bounded applications upon hierarchical data gathering tree. With respect to the basic CSMA/CA scheme, DB-MAC introduces two novel mechanisms: (i) RTS/CTS messages are exploited to perform data aggregation, and (ii) backoff intervals (BI) are computed by taking into account the priority assigned to different transmissions. Specifically, each node can take advantage of transmissions from other nodes by overhearing CTSs to facilitate a data aggregation close to the source. When a source starts transmitting, the priority, P_r , is set to the maximum, $P_{r_{MAX}}$. P_r is then decreased by one at each hop. The receiving node decrements the priority by 1 from $P_{r_{MAX}}$ to $P_{r_{MAX}} - 1$, and forwards the packet to the next node, which will contend for medium access with priority $P_{r_{MAX}} - 1$. The BI value is set between 0 and 1023 tics, depending on the value of the priority. Therefore, a node will obtain medium access with a high probability if it is close to the source. Figure 6 depicts the access scheme timing. By combining these two mechanisms, a node gains access to the medium with a higher probability if it is close to the source and it performs the path aggregation as close as possible to the transmitting sources. Thus, the total number of transmissions as well as the latency can be reduced when compared to IEEE 802.11 scheme.

Note that both DMAC and DB-MAC are built on application-specific data gathering tree which will limit their usage in general topology. Latency is reduced or minimized but no explicit RT guarantee is offered. Usually, a MAC protocol only addresses channel access schedule in single hop manner. It is interesting to see that DMAC and DB-MAC have MAC with some routing considerations. The result will be favorable to tree-based routing protocols and helpful to delay sensitive data gathering.

Z-MAC (Zebra-MAC) [17] is a hybrid MAC protocol which dynamically switches between CSMA and TDMA depending on the level of contention. Z-MAC assign sensor nodes time slots, but also allows sensor nodes to utilize those slots they do not own through CSMA

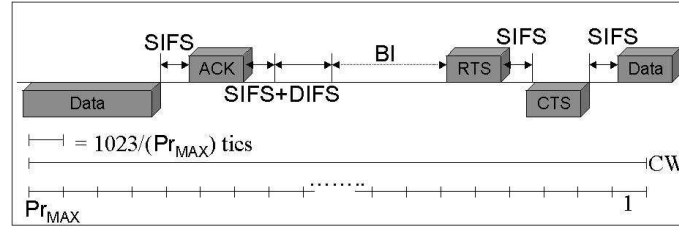

Figure 6: The contention mechanism in DB-MAC [16]

with prioritized backoff times. This provides Z-MAC the capability to perform similarly as CSMA when applications generate less traffic, but approximates a strict TDMA scheme when traffic requirements increase. Prior to sensor network operations, a distributed slot assignment protocol provides sensor nodes the time slots they may utilize for transmission. During each time slot, sensor nodes use CSMA to determine who may transmit. However, Z-MAC gives the slot owner a preference in channel access by increasing the initial backoff time for sensor nodes that do not own the slot. The owner of the current slot selects a random backoff time of up to T_o and performs CSMA. Using a random backoff, the slot owner limits the effect of incorrect synchronization among neighboring sensor nodes. Sensor nodes that do not own the current slot select a backoff time between T_o and T_{no} , where $T_{no} > T_o$, and perform CSMA. Sensor nodes receive messages according to the B-MAC protocol and maintain a receive schedule independent of the time slots. Generally, Z-MAC outperforms B-MAC under medium to high contention while it is a little worse under low contention. Z-MAC's greatest advantage comes from its easy and rapid adaptability to traffic conditions. Approximating a CSMA protocol under light traffic conditions and a TDMA protocol under heavy traffic conditions can save a large amount of energy. Further benefits come from Z-MAC's robustness against synchronization errors. Compared to other protocols, Z-MAC requires few processing and memory resource. These benefits come at the cost of protocol overhead, primarily caused by the TDMA structure. Although Z-MAC is not specifically designed for RT service, the idea of switching between TDMA and CSMA based protocols is inspiring.

PEDAMACS [18] is a TDMA-based MAC protocol that extends the common single-hop TDMA to a multi-hop sensor network. It aims to achieve both energy efficiency and delay guarantee. PEDAMACS considers a special class of sensor networks with high-powered access point (AP) which can reach all nodes in one hop and with nodes periodically generating packets. The protocol operates in four phases: topology learning, topology collection, scheduling, and adjustment. In the topology learning phase, each node identifies its local topology, i.e., its neighbors, interferers, and its parent node in the routing tree rooted at the AP obtained according to some routing metric. In the topology collection phase, each node sends its local topology information to the AP such that, at the end of this phase, the AP knows the full network topology. At the beginning of the scheduling phase, the AP

broadcasts a schedule. Each node then follows the schedule and sleeps during time slots when it is not scheduled to transmit a packet or to listen for. The adjustment phase is triggered as necessary so as to learn the local topology information, that was not discovered during the topology learning phase, or to discover changes. Topology information is gathered by AP and a scheduling algorithm is then adopted to determine when a node should transmit and receive data. Some extensions of PEDAMACS to handle non-periodic data generation, existence of more than one AP, and nodes located beyond the range of AP are possible as reported [18]. PEDAMACS guarantees bounded delay and eliminates network congestion. However, the requirement of powerful AP has restricted the protocol to only few applications and weakened its attractiveness.

IEEE 802.15.4 standard specifies the physical layer (PHY) and MAC sublayer for low-data-rate low-cost wireless personal area networks (WPANs) of fixed, portable, and moving devices with no battery or very limited energy consumption requirements [19]. It supports star as well as peer-to-peer topologies. These features make it promising for WSNs. Basically, the medium access employs CSMA-CA mechanism. Two operation modes are supported: (i) beacon-enabled (slotted) mode, and (ii) non beacon-enabled (un-slotted) mode. The un-slotted operation is generally more flexible and scalable, but it is unable to support deterministic time guarantee for RT service. On the other hand, in the beacon-enabled mode, by the defined superframe structure as shown in Figure 7, time slots in the contention-free period (CFP) can be reserved for devices with time critical data upon their allocation request message. In this operation, the PAN coordinator can allocate portions of the active superframe to form guaranteed time slots (GTSs) and provide dedicated service. Both CFP and slotted CSMA-CA based contention access period (CAP) are defined under the beacon-enabled mode to support different message delivery demands.

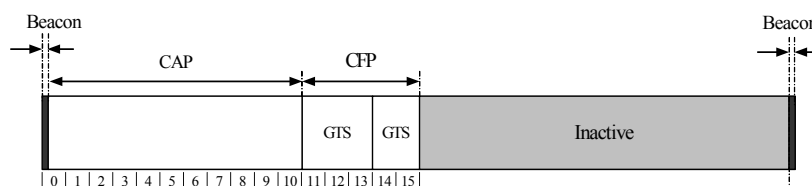

Figure 7: The superframe structure with GTSs [19]

For RT-WSNs, although IEEE 802.15.4 protocol has provided GTS mechanism for time critical data, details of how to use it to support explicit QoS guarantees are still developing. It is possible to let the PAN coordinator distribute GTSs corresponding to the deadline and bandwidth requirements of transmissions so as to support HRT guarantees [20]. It should be pointed out that the current IEEE 802.15.4/Zigbee specifications restrict the synchronization in beacon-enabled mode to star-based network. For meshed topology, there is another necessity to avoid beacon and GTS collisions. Koubâa *et al.* [21] analyze the problem of direct and indirect beacon collisions and propose the superframe duration scheduling

algorithm, which efficiently organizes the superframe duration of different coordinators in a non-overlapping manner, based on their superframe orders and beacon orders. Another proposal is based on beacon organization in a beacon-only-period at the beginning of the superframe, where the beacon-only-period is composed of CFTS (Contention Free Time Slot) reserved by the PAN coordinator. Francomme *et al.* [22] complete the above work with one rule which allows to check whether the PAN supervisor location provides an efficient synchronization for numerous clusters, i.e. to reach the farthest router within a minimum hops. They also propose an algorithm that allows organizing the GTS in CFP sections of nearby coordinators and avoiding simultaneous transmissions. Instead of providing strict deterministic guarantee, enhanced CSMA/CA MAC mechanisms may be designed to offer soft delay guarantees [23]. For example, priority toning strategy is used in [24]. A node will send a tone signal to the PAN coordinator to request it alerting other nodes to defer their contentions so as to support a fast delivery of high priority frames. In [23], traffics are categorized into high and low priority queues which employ different CSMA/CA settings. The result offers a heuristic solution to provide different QoS for messages of different priorities. Service differentiation of packets in MAC appears promising for QoS control in WSNs.

A comparison of the aforementioned MAC protocols is given in Table 1 to identify their QoS support and major differences.

Table 1: A comparison of the discussed MAC protocols

Name	MAC type	RT type	Topology dependent	Energy efficiency	Scalability
S-MAC, T-MAC	CSMA/CA	best effort	no	high	good
B-MAC	CSMA/CA	best effort	no	high	good
I-EDF	FDMA-TDMA	HRT	cell structure	N/A	moderate
Dual-mode MAC	FDMA-TDMA	HRT	cell structure	N/A	moderate
DMAC	slotted contention-based	best effort	tree structure	moderate	good
DB-MAC	contention-based	best effort	tree structure	high	good
Z-MAC	CSMA-TDMA	best effort	no	high	moderate
PEDAMACS	TDMA	HRT	no	high	low
IEEE 802.15.4	CSMA/CA, GTS	best effort/HRT	no	moderate	good

2.2 RT Routing Solutions

Even if RT guarantee can be provided in MAC layer, packet deadline still cannot be met if there is no transmission delay bound in network layer. As mentioned before, DMAC and DB-MAC are designed on a tree topology which is a multi-hop network with packet routing capability, therefore they can naturally support a bounded delay in both MAC and network layer. For RT-WSNs, routing protocols that can provide deterministic or probabilistic delay guarantee are favored. For example, if the routing protocol is location-aware or tree-based,

it is easier to estimate the delay by computing the distance between the source and sink or by checking the depth in the tree. However, if a routing protocol is based on random broadcasting, it will be difficult to guarantee a delay bound. Some protocols are designed to reduce transmission or queuing delay but without deterministic or probabilistic guarantee. Therefore, in nature they do not support RT QoS but just provide best effort service.

SPEED [25] is a RT routing protocol for soft end-to-end deadline guarantee by maintaining a packet delivery speed across the network which should be greater than or equal to the desired velocity v defined by the ratio of straight line distance from source s to target t over the required deadline, as shown in Figure 8. The core module is the stateless non-deterministic geographic forwarding (SNGF), which sends packets to the downstream node capable of maintaining the desired delivery speed. If there is no neighboring node which can support the desired speed, it probabilistically drops packets to regulate the workload. The MAC layer gives feedback on the miss information to the relay ratio controller (RRC). The RRC will determine the relay ratio, which is fed back to SNGF. Based on the ratio, SNGF can make decisions on whether to drop or forward a packet. At the same time, a backpressure packet re-routing around large-delay links is included to reduce or divert the traffic injected to a congested area. The protocol treats a void in the same way it handles congestion and guarantees that a greedy route will be found if there exists. The desired network-wide speed is maintained such that SRT end-to-end delivery is obtained with a theoretical delay bound. Besides, the mechanism works in a localized way which makes it quite scalable. One problem with SPEED is that it does not guarantee packet delivery. Their void avoidance algorithm may result in dropped packets. Furthermore, the value of required speed is fixed which does not support packets with different deadline requirements.

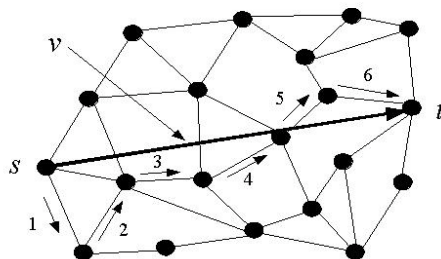

Figure 8: SPEED: desired velocity v is defined by the ratio of the distance from source s to target t over the required deadline [25]

MMSPEED [26] is an extension of SPEED which supports service differentiation and probabilistic QoS guarantee. For delivery timeliness, multiple network-wide packet delivery speed options are provided for different traffic types according to their end-to-end deadlines. MMSPEED can be conceptually considered as a virtual overlay of multiple SPEED layers. Virtual isolation is accomplished by classifying incoming packets according to their

speed requirements and placing into appropriate priority queues as shown in Figure 9. A priority queue follows FCFS discipline. After the service differentiation, each speed layer is mapped to one MAC priority class such that one with a higher speed requirement will have a higher priority. Therefore, prioritization in network layer is combined with prioritized MAC such that probabilistic delivery guarantee can be provided. In supporting service reliability, probabilistic multi-path forwarding is used to control the number of delivery paths based on the required end-to-end reaching probability. It combines the two strategies: (i) multi-path forwarding based on local estimation, and (ii) dynamic compensation. Specifically, each node locally determines multiple forwarding nodes to meet the required reaching probability based on local error estimations and the information of geographic hop distances to immediate neighbors. However, it should be noted that decisions on multiple forwarding node selection may be incorrect in the following nodes since local estimations are used to model the remaining part of the network about which the local node does not have any information. Therefore, they use hop-by-hop dynamic compensation for the reliability. With this probabilistic multi-path forwarding, packets with different reliability requirements are differentiated and the probability that a packet reaches the destination should be higher than its requirement. Like SPEED, since all mechanisms in MMSPEED work locally without global network state information and end-to-end path setup, it is scalable and adaptive to network dynamics. However, both SPEED and MMSPEED have a common deficiency: energy consumption metric has not been taken into account.

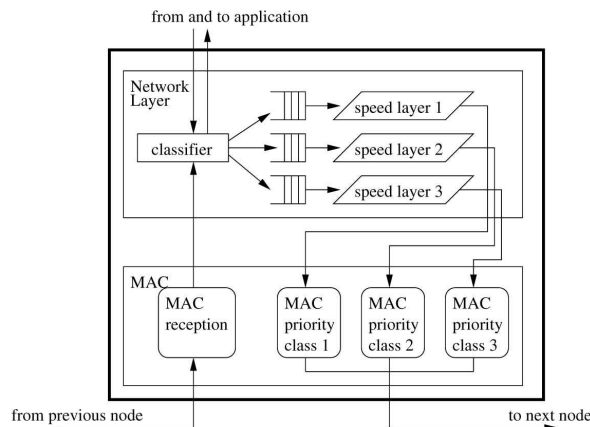

Figure 9: Protocol structure of MMSPEED [26]

A real-time power-aware routing (RPAR) protocol [27] is proposed to achieve application specified communication delay at low energy cost by dynamically adjusting transmission power and routing decisions. It allows the application to control the tradeoff between energy consumption and communication delay by specifying packet deadlines. Specifically, when

deadlines are tight, RPAR increases the transmission power to trade capacity and energy for required delay. Conversely, when deadlines are loose, RPAR lowers the transmission power to increase throughput and save energy. RPAR is comprised of four components: a dynamic velocity assignment policy, a delay estimator, a forwarding policy, and a neighborhood manager. Velocity assignment policy is used to map a packet's deadline to a required velocity, which is computed by the progress made toward the destination over the packet's slack (slack is the time remaining until the packet's deadline expires). The delay estimator evaluates the one-hop delay of each forwarding choice in the neighbor table. Based on the required velocity and the information provided by the delay estimator, RPAR forwards the packet in a most energy efficient way that meets the required velocity. When there is no candidate that can meet the required velocity, the neighborhood manager attempts to find a new one by power adaptation and neighbor discovery. Moreover, Important practical issues like lossy links, memory and bandwidth constraints and scalability are considered in the protocol.

Akkaya *et al.* [28] propose an energy-aware QoS routing protocol that will find energy-efficient path along which the end-to-end delay requirement can be met. It is assumed that each node has a classifier to check the type of incoming packets and divert RT and non-RT traffic to different priority queues. There is also a scheduler, which determines the order of packets to be transmitted from the queue according to the bandwidth ratio r of each type of traffic on the link. The queueing model is depicted in Figure 10. The queueing delay depends on the value of r . Therefore, the delay requirement is converted into bandwidth requirement. Their approach is based on associating a cost function for each link and uses an extended version of Dijkstra's algorithm to find an ascending set of least cost paths. These paths are checked against the end-to-end deadline constraints and the one that provides maximum throughput for non-RT traffic is picked. To support end-to-end guarantee, their approach however does not take into account the delay that occurs due to channel access at the MAC. Moreover, the use of class-based priority queuing mechanism is too complicated and costly for resource limited sensors.

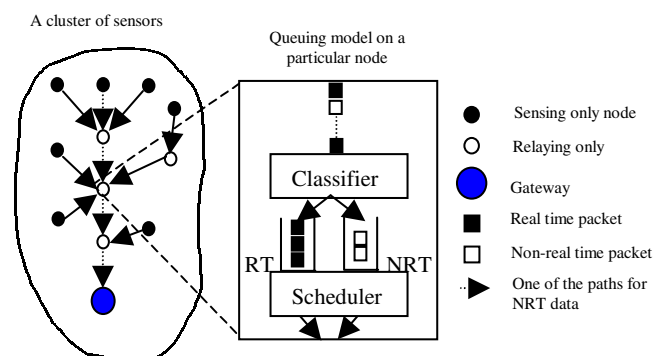

Figure 10: Queuing model in cluster-based sensor network [28]

Pothuri *et al.* [29] design a heuristic solution to find energy efficient path for delay constrained data in WSNs. They investigate the delay-constrained energy-efficient routing problem (DCEERP) in sensor networks. Given a delay bound of d' seconds, the task is to find a path from a source node to the sink with the lowest energy consumption such that the total transfer delay incurred along the path is less than d' seconds. Conventional DCEERP solutions are not adequate as MAC delay is not included. Therefore, they employ topology control and have a modeling of the contention delay caused by MAC layer. A set of paths between source and sink nodes are identified and indexed in the increasing order of their energy consumption. End-to-end delay is estimated along each of the ordered paths and the one with the lowest index that satisfies the delay constraint is selected. Their study shows that the proposed framework achieves a good balance between latency introduced by the transfer and energy consumption. However, their solution is based on the assumption that nodes are equipped with two radios: a low-power radio for short-range and a high-power radio for long-range communication such that each node can reach the sink directly using its long-range radio. Generally speaking, this requirement is energy inefficient and may not be practical.

Ergen *et al.* [30] presents an energy efficient routing method with delay guarantee for sensor networks. They first exclude the delay constraint and formulate the lifetime maximization as a linear programming (LP) problem, and propose a routing protocol in a centralized implementation. The protocol is based on decomposing the LP solution into multiple routing trees. It is a centralized algorithm. A distributed routing protocol is then proposed to implement this decomposition by a sequence of least cost path problems, where the cost of a path is the sum or the maximum of the cost of nodes on that path while the cost of a node is defined as a function of its initial and remaining battery energy. This distributed implementation provides a platform to simultaneously achieve energy-efficient routing and delay guarantee, since delay guarantee cannot be introduced into LP formulation before the decomposition. Afterwards, the paper extends the energy efficient routing to provide a guarantee on the maximum delay each packet experiences. They assume that the transmission rate is fixed and the number of hops each packet experiences in the network is limited in order to provide the worst case delay bound. The simulation shows that the maximum delay can be limited to a certain level. However, one may find that the result is not flexible to meet application specified delay bound in general.

Boughanmi and Song [31] propose a routing metric for evaluating path efficiency which includes the delay, the path reliability and the energy utility. The path efficiency is defined as the ratio of the energy efficiency to the end-to-end delay, where the energy efficiency is further specified considering link failure and retransmissions. End-to-end delay is supposed to be the hop count between the source and the sink and is collected by routing response message in the initialization phase. The new routing metric is applied in AODV routing protocol with IEEE 802.15.4 MAC sublayer and the simulation results show that the proposed method improves network lifetime and end-to-end delivery ratio compared to traditional AODV and the metric in [30]. Although this solution does not provide deterministic time guarantee,

the expected hop count is included in choosing the forwarding path, which in a simplified way may indicate the delay time.

Zigbee defines the network and application layers on the top of physical and MAC layer normalized by IEEE 802.15.4. The network layer uses a modified AODV by default and hierarchical tree routing (HTR) as last resort. Nefzi and Song [32] analyze both AODV and HTR and compare their performance in terms of end-to-end delay and energy consumption. It is found that the network with HTR has smaller average end-to-end delay and longer lifetime than that with AODV. However, AODV performs better in end-to-end delay in HTR's worst case. Besides, The energy consumption of AODV is more uniformly distributed. An improvement is made by using a neighbor table in routing decision to solve the worst-case delay problem in HTR and shorten the worst-case routing path. If we simply use hop count as an indication of end-to-end delay, HTR is suitable for guarantee the delay time by simply measuring the hop count from source to destination.

As a summary, Table 2 gives a comparison between the previously mentioned RT routing protocols. It indicates their major differences between one another.

Table 2: A comparison of the discussed routing protocols

Name	Routing Type	RT type	Link reliability	Energy efficiency	Scalability
SPEED	location aware	SRT	N/A	N/A	good
MMSPEED	location aware	SRT	high	N/A	good
RARP	location aware	SRT	high	high	good
EA-QoS	cluster-tree	SRT	moderate	high	low
Pothuri	tree	SRT	N/A	moderate	moderate
Ergen	tree	HRT	N/A	high	moderate
E-AODV	cluster-tree	best effort	high	high	good
HTR	cluster-tree	hop guarantee	N/A	moderate	good

2.3 RT Data Processing

Data processing strategies at sensor nodes can help to enhance the capability of QoS guarantee in WSNs. In-network data aggregation may improve energy efficiency. It is worth identifying their impacts on the provided service quality, resultant bandwidth utilization efficiency, and also required system overheads. In particular, we are interested in the data timeliness.

Hu *et al.* [33] have investigated the energy efficiency of data aggregation tree in WSNs. An analytic model based on IEEE 802.15.4 CSMA/CA is developed to compute a node's worst case delay in aggregating data from all child nodes. A heuristic algorithm is then proposed for constructing data aggregation tree to minimize total energy cost under specific latency bound. However, the proposed solution is in a centralized algorithm.'

Zhu *et al.* [34] study an QoS-based data aggregation and processing approach for sensor networks. End-to-end latency is taken into account to determine whether, when, and where to perform the aggregation in a distributed manner. A localized adaptive data collection algorithm performed at the source node is thus developed to balance the design tradeoffs between delay, measurement accuracy, and buffer overflow. Note that the design is only evaluated in a fixed network. Its operations and performance in dynamic systems need to be verified to show its effectiveness.

Yu *et al.* [35] study the energy-latency tradeoff in data gathering of mission critical RT applications. They consider packet scheduling in a tree structure and employ a precisely defined non-monotonic energy cost model. The core is to find a packet transmission schedule which can minimize the energy cost within the allowed latency. Energy saving is observed. The paper has also reported the importance of an explicit energy consumption model in WSN system design and optimization.

He *et al.* [36] defines a four-tier data aggregation architecture with: (i) raw data aggregation, (ii) in-node aggregation, (iii) group aggregation, and (iv) base aggregation for a RT tracking system called VigilNet. The architecture has been implemented in a real application. Besides, the scheme has considered cross-layer issues. It can flexibly achieve a balance between energy, timeliness, and data availability. We will discuss it in next section and show a complete picture with details.

2.4 Cross-layer Solutions

From a holistic point of view, it is reasonable to consider RT issues cross different layers in the communication stack. For example, information sharing among physical, MAC, and network layers can help to conduct a more efficient radio resource allocation and traffic scheduling in the packet delivery. The following designs have provided RT guarantee in a cooperative cross-layer fashion which is an increasingly important research area.

RAP [37] is a cross-layer RT communication architecture for large-scale sensor networks. The architecture of RAP is shown in Figure 11. Sensing and control applications interact with RAP through Query/Event service APIs. The communication is supported by a scalable and efficient protocol stack, which integrates the transport-layer location-addressed protocol (LAP), geographic routing protocol (GF), velocity monotonic scheduling (VMS) policy, and contention-based MAC with packet prioritization. LAP is a connectionless transport layer in the network stack. It is similar to UDP except that all messages are addressed by location instead of IP address. GF makes a greedy localized routing decision to forward a packet to a neighbor. The cornerstone of RAP is the VMS policy, which is based on packet requested velocity that reflects both distance and timing constraints. A packet with higher requested velocity is assigned a higher priority. VMS reduces end-to-end deadline miss ratio by giving higher priority to packets with higher requested velocities. Moreover, to enforce packet priorities, they modified two components of the standard IEEE 802.11 implementation. The initial waiting time after the channel becomes idle and the backoff window increase functions are modified to ensure that packets with high priority have high probability to get the channel in both contention avoidance phase and contention

phase. Simulations show that RAP has effectively reduced the deadline miss ratio. The result demonstrates that a multi-layer location-based communication stack with velocity based prioritization can improve the RT performance in WSNs.

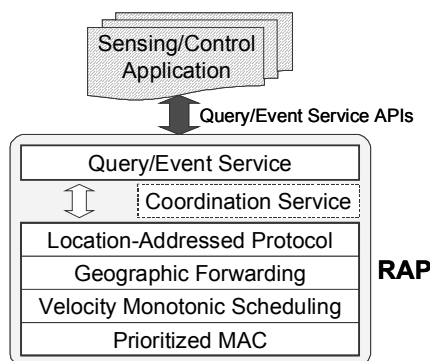

Figure 11: RAP architecture [37]

MERLIN [38] is a lightweight protocol that integrates routing and MAC protocols to support energy efficiency and low latency in WSNs. The core idea in the MERLIN protocol is the time-zone concept, in which a sensor network is sub-divided into time zones and nodes set their time-zone number by the number of hops to get to the closest gateway. Two types of data traffics are supported: downstream multi-cast and local broadcast. MERLIN MAC follows a hybrid TDMA/CSMA approach. Periodic node activity is regulated by the node's scheduling table, which allocates time slots to the node to assign activity and inactivity. It is intended that when a zone is scheduled for local broadcast, nodes within the same zone and adjacent ones are in listening mode. All time slots are provided with a contention period (CP) located at the beginning of the time slot as shown in Figure 12. MERLIN adopts clear channel assessment (CCA) and low power listening (LPL) used in B-MAC [11] at the receiver. A node that wishes to transmit initially will choose a random time within the contention period and wake up at that time to sense the channel for a CCA period. If nothing is detected, the node immediately starts transmitting the packet preamble, the duration of which is T_c equal to whole CP length. In this way, the preamble transmission is guaranteed to reach the end of the CP. The data packet is transmitted immediately after the preamble. MERLIN adopts an implicit routing policy. It does not specify a forwarding node, however, the division in time-zones together with the described scheduling and type of data traffic allow packets to be routed to or away from the closest gateway. Mechanisms of overhearing and on-demand time zone maintenance are taken to reduce duplication of packets. The result shows that MERLIN outperforms the integration of S-MAC and ESR (Eyes Source Routing) [39] in both energy efficiency and latency. However, it should be noted that generally speaking S-MAC and ESR are not designed for RT applications. The delay performance of MERLIN is worth of being investigated more specifically.

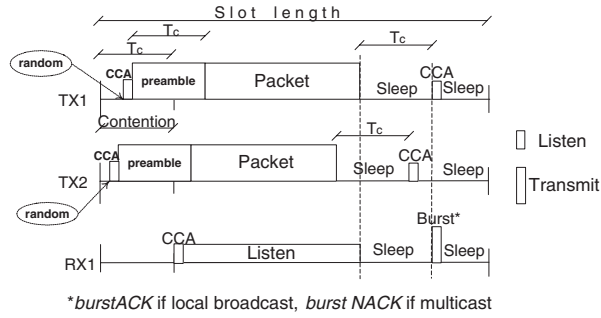

Figure 12: Transmission mechanism for collision avoidance of MERLIN [38]

VigilNet [2] is a large scale RT sensor system for target tracking, detection, and classification. It aims at both timeliness and energy efficiencies. Specifically, it will detect, analyze, and classify the incoming target within a certain end-to-end deadline. The network infrastructure in VigilNet is a multi-path diffusion tree, rooted at bases. B-MAC is the default MAC protocol, which has a certain uncertainty in the communication delay. Deadline partition method is used to guarantee an end-to-end tracking deadline by satisfying a set of sub-deadlines. Figure 13 shows the architecture of VigilNet. In [2], multi-dimensional tradeoffs between RT performance and other system properties are investigated. The real-time design and tradeoffs are studied by large-scale experiments and simulations, which reveal some practical design suggestions that can be applied to other real-time systems.

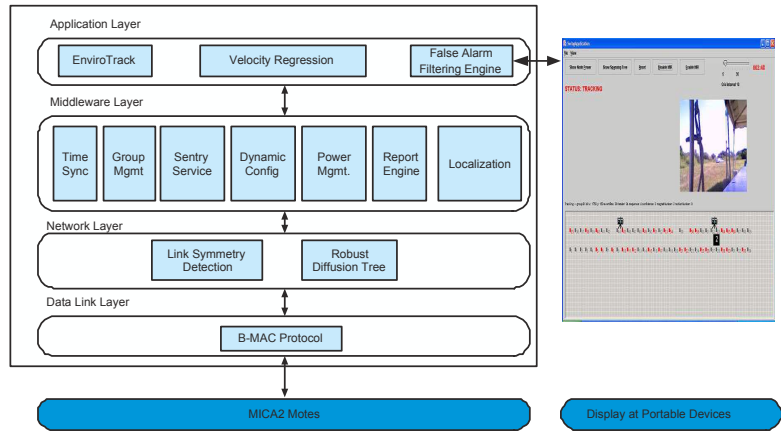

Figure 13: VigilNet architecture [2]

Figure 14 illustrates a simplified cross-layer framework for RT-WSNs. Following the typical communication stack, parameters in lower layer are reported to adjacent higher layer. As shown in Figure 14, the cross-layer design enables a higher layer to coordinate the behavior of lower layers. Parameters of distant layers can have interactions as well. For example, the application layer may have QoS requirement like end-to-end delay bound and service differentiation, which will place a delay constraint and have priority scheduling in routing layer and MAC layer. Physical layer determines the amount of energy spent in transmission and circuit. It also provides the link quality indication (LQI) to the MAC, routing and application layers. LQI can provide a reference for the scheduling at MAC layer, reflect the reliability and robustness of routing path, and also affect the source coding at the application layer. Besides, the active/idle/sleep action at MAC layer will help optimizing the performance of routing layer. There are impacts on one another.

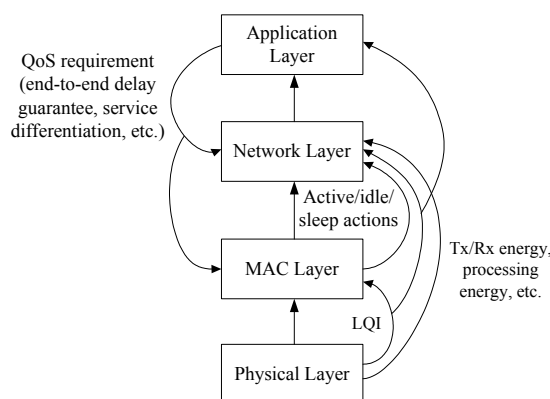

Figure 14: Cross-layer design for RT-WSNs

Generally speaking, cross-layer design can be conducted in two ways. The first aims at improving the performance of the communication protocol by taking into account parameters in other layers, while the second is to merge relevant protocols into one component. Although the latter can allow much closer interaction among protocols, it is difficult to make the relationship clear. Meanwhile, the functionality of the merged component can be very complex. Therefore, it is better to leave some transparency between layers.

3 Challenges and Open Issues

To ensure the acquisition of timely information from source to destination, delay control is always at the core of a RT-WSN. Based on the literature study and previous discussions, we have the following summary and suggestions.

3.1 Soft and Hard RT

As shown in Figure 15, for RT communication, any node participating in the WSN should be able to support guaranteed medium access delay in each single-hop and also bounded routing delay in multi-hop. Logically, only the combination of HRT MAC and HRT routing protocols can lead to a HRT end-to-end deadline guarantee. For example, in MAC, a contention-free protocol such as I-EDF is inherently suitable for HRT service. However, the protocol scalability, system requirements, and overheads incurred should be carefully considered. Alternatively, the other three combinations will commonly reach SRT support. Contention-based protocols have the capability of providing statistical performance bound. Meanwhile, packet prioritization can be embedded for enhancement. In general, people could integrate different protocols in respective layers to meet their RT requirements. It should be noted that due to the wireless link unreliability, a design with both HRT MAC and HRT routing could still fall into a probabilistic QoS guarantee.

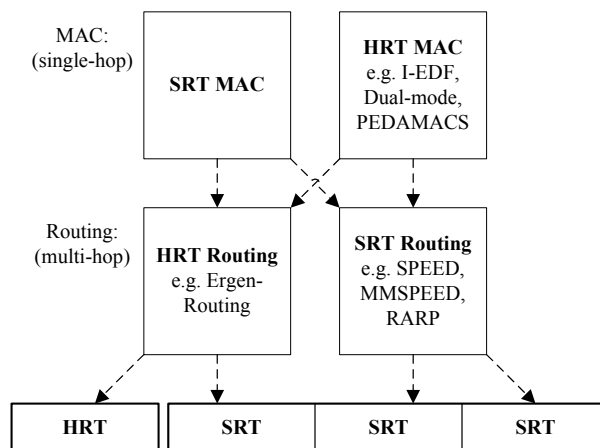

Figure 15: Combinations of MAC and routing protocols for RT QoS support in WSNs

Generally speaking, although providing deterministic delay guarantee is often more favorable for a RT system, it could easily result in an overly conservative end-to-end bound and low resource utilization efficiency especially for a large scale and dynamic WSN. Probabilistic guarantee is another option which has less system requirements and seems to be more promising. However, explicit probabilistic guarantees should be provided for SRT support. A best-effort service is insufficient.

3.2 RT and Energy Efficiency

Since sensors are usually energy constrained devices, providing RT service guarantee is challenging especially when energy efficiency needs to be put on a higher priority. This

reduces the flexibility in the protocol design and gives more constraints to an optimization for RT requirements. Without loss of generality, how to make a balance between energy efficiency and delay guarantee is an interesting problem. A joint optimization of tunable metrics with well-defined cost functions may offer an effective solution. It is reasonable that a RT-WSN design may sacrifice some energy efficiency in order to achieve message delivery timeliness. For example, by a larger transmission power, a message delivery to the destination can be conducted in a smaller number of hops.

3.3 Multi-source Multi-sink Model

Most of the existing WSN protocol designs aim at multiple source to single destination model. It should be noted that the result may not be applicable to a more sophisticated multi-source multi-sink system. Conflicts can occur among crossed tasks in the network. It is challenging to satisfy the deadline requirements of multiple tasks simultaneously. In wireless sensor-actuator networks (WSANs), sensors have multiple potential destinations (e.g. actuators) in event reporting. Besides, actuators could be mobile in conducting actions [40]. The resulting heterogenous system is quite different from a traditional data collecting WSN model with single static sink.

Note that, in WSANs, actuators are often assumed resource-rich and with high energy and communication capability. This implies a possibility of using them as fast relays to transmit data collected from sensors to a destination directly or in a few hops for time-critical service. Future investigations and interesting applications are expected.

3.4 Data Aggregation

Comparing data centric with application oriented WSNs, one can find that the former usually only aims to deliver packets to destination before deadlines. In an application oriented WSN, events instead are required to be reported in time. Simple end-to-end data delay bound is insufficient [6] for application oriented WSNs. It is interesting to consider in-network data aggregation so as to allow a faster information delivery after data redundancy elimination. This not only saves transmission energy but also helps to prevent network congestion. Application-level delay can thus be reduced. However, this may also lead to extra delivery delay due to the processing time for aggregation.

3.5 Multi-dimensional QoS Support

While offering RT QoS support, there should be a system flexibility to support different applications with respect to their different QoS requirements in the mixed traffics. Roughly speaking, they can be categorized as RT reliable service, best-effort service, bursty event reporting, and simple rate-matched service. A flexible integrated architecture with configurable performance metrics in well defined cost functions will be of great help to the future development of RT-WSNs.

3.6 QoS Support for Mobile WSNs

Most of the current communication protocols supporting RT QoS assume a WSN with low mobility. However, the targets, sensors and actuators may be highly mobile. A static or periodically updated neighborhood information will be insufficient. There is a need for new protocols specifically designed for supporting QoS in highly dynamic WSNs and provide effective control [?].

4 Conclusions

Supporting RT QoS in WSNs is a new area of research. A comprehensive study of current RT-WSN solutions has been presented in this report with respect to different MAC, routing protocols, data aggregation design, and cross-layer solutions. They have the common objective of trying to provide timeliness guarantee for delay constrained wireless sensor systems. Their advantages and disadvantages are discussed and compared. Besides, the design trade-off between energy and delay is also highlighted. Although several designs may have nice energy efficiency and delay performance, for explicit RT service support, there are still many challenges and issues that need to be addressed in detail. We have pointed out the open questions for future research and potential advancement. Supporting RT QoS in WSNs will be a challenging and interesting area in the coming years.

References

- [1] C.-Y. Chong, S. P. Kumar, "Sensor networks: evolution, opportunities, and challenges," *Proc. IEEE*, vol. 91, no. 8, pp. 923–933, November 2006.
- [2] T. He, A. Pascal, T. Yan, L. Luo, L. Gu, G. Zhou, R. Stoleru, Q. Cao, J. Stankovic, and T. Abdelzaher, "Achieving real-time target tracking using wireless sensor networks," in *Proc. IEEE RTAS*, pp. 37–48, September 2006.
- [3] D. Malan, T. Fulford-Jones, M. Welsh, and S. Moulton, "Codeblue: an ad hoc sensor network infrastructure for emergency medical care," in *Proc. Int. Workshop Wearable Implantable Body Sens. Networks*, April 2004.
- [4] Y. Li, Z. Wang, and Y. Q. Song, "Wireless sensor networks for wildfire monitoring," in *Proc. World Congr. Intell. Contr. Autom.*, pp. 109–113, June 2006.
- [5] S. Glaser, "Sensing structural integrity," Online available: <http://www.ce.berkeley.edu/~glaser/CUREe.pdf>.
- [6] J. Stankovic, T. Abdelzaher, C. Lu, L. Sha, and J. Hou, "Real-time communication and coordination in embedded sensor networks," *Proc. IEEE*, vol. 91, no. 7, pp. 1002–1022, July 2003.

- [7] Y. Yu, B. Krishnamachari and V. K. Prasanna, "Issues in Designing Middleware for Wireless Sensor Networks," in *IEEE Network Mag.*, vol. 18, no. 1, January 2004.
- [8] S. Hadim and N. Mohamed, "Middleware: middleware challenges and approaches for wireless sensor networks," in *IEEE Distrib. Syst.*, vol. 7, no. 3, March 2006.
- [9] W. Ye, J. Heidemann, and D. Estrin, "Medium access control with coordinated adaptive sleeping for wireless sensor networks," *IEEE/ACM Trans. Netw.*, vol. 12, no. 3, pp. 493–506, June 2004.
- [10] T. van Dam and K. Langendoen, "An adaptive energy-efficient MAC protocol for wireless sensor networks," in *Proc. ACM Sensys*, pp. 65–72, November 2003.
- [11] J. Polastre, J. Hill, and D. Culler, "Versatile low power media access for wireless sensor networks," in *Proc. ACM Sensys*, pp. 95–107, November 2004.
- [12] G. Halkes, T. V. Dam, and K. Langendoen, "Comparing energy-saving MAC protocols for wireless sensor networks," *Mobile Networks and Applications*, no. 10, pp. 783–791, 2005.
- [13] M. Caccamo, L. Zhang, L. Sha, and G. Buttazzo, "An implicit prioritized access protocol for wireless sensor networks," in *Proc. 23rd IEEE RTSS*, pp. 39–48, December 2002.
- [14] T. Watteyne, I. Augé-Blum, and S. Ubéda, "Dual-mode real-time MAC protocol for wireless sensor networks: a validation/simulation approach," in *Proc. InterSense*, May 2006.
- [15] G. Lu, B. Krishnamachari, and C. Raghavendra, "An adaptive energy-efficient and low-latency MAC for data gathering in wireless sensor networks," in *Proc. IPDPS*, pp. 224–231, April 2004.
- [16] G. Bacco, T. Melodia, and F. Cuomo, "A MAC protocol for delay-bounded applications in wireless sensor networks," in *Proc. Med-Hoc-Net*, pp. 208–220, June 2004.
- [17] I. Rhee, A. Warriar, M. Aia, and J. Min, "Z-MAC: a hybrid MAC for wireless sensor networks," in *Proc. ACM Sensys*, pp. 90–101, November 2005.
- [18] S. Ergen and P. Varaiya, "PEDAMACS: power efficient and delay aware medium access protocol for sensor networks," *IEEE Trans. Mobile Comput.*, vol. 5, no. 7, pp. 920–930, July 2006.
- [19] IEEE Std 802.15.4, "Part 15.4: Wireless medium access (MAC) and physical layer (PHY) specifications for low-rate wireless personal area networks (WPANs)," IEEE-SA Standards Board, September 2006.

- [20] J. Francomme, G. Mercier, and T. Val, "A simple method for guaranteed deadline of periodic messages in 802.15.4 cluster cells for control automation applications," in *Proc. IEEE ETFA*, pp. 270–277, September 2006.
- [21] A. Koubâa, M. Alves, M. Attia, and A. V. Nieuwenhuyse, "Collision-free beacon scheduling mechanisms for IEEE 802.15.4/Zigbee cluster-tree wireless sensor networks," in *Proc. Workshop Applications and Services in Wireless Networks*, 2007.
- [22] J. Francomme, G. Mercier, and T. Val, "Beacon synchronization for GTS collision avoidance in an IEEE 802.15.4 meshed network," in *Proc. IFAC FeT*, pp. 215–222, November, 2007.
- [23] A. Koubâa, M. Alves, B. Nefzi, and Y. Q. Song, "Improving the IEEE 802.15.4 slotted CSMA/CA MAC for time-critical events in wireless sensor networks," in *Proc. Workshop Real-Time Networks*, pp. 270–277, July 2006.
- [24] T. Kim and S. Choi, "Priority-based delay mitigation for event-monitoring IEEE 802.15.4 LR-WPANs," *IEEE Common. Letters*, vol. 10, no. 3, pp. 213–215, March 2006.
- [25] T. He, J. Stankovic, C. Lu, and T. Abdelzaher, "SPEED: a stateless protocol for real-time communication in sensor networks," in *Proc. ICDCS*, pp. 46–55, May 2003.
- [26] E. Felemban, C. Lee, and E. Ekici, "MMSPEED: Multipath multi-speed protocol for QoS guarantee of reliability and timeliness in wireless sensor network," *IEEE Trans. Mobile Comput.*, vol. 5, no. 6, pp. 738–754, June 2006.
- [27] O. Chipara, Z. He, G. Xing, Q. Chen, X. Wang, C. Lu, J. Stankovic, and T. Abdelzaher, "Real-time power-aware routing in sensor network," in *Proc. IWQoS*, pp. 83–92, June 2006.
- [28] K. Akkaya and M. Younis, "An energy-aware QoS routing protocol for wireless sensor networks," in *Proc. Int. Conf. Distrib. Comput. Syst. Workshops*, May 2003, pp. 710–715.
- [29] P. Pothuri, V. Sarangan, and J. Thomas, "Delay-constrained energy efficient routing in wireless sensor networks through topology control," in *Proc. IEEE Int. Conf. Netw. Sensing Control*, pp. 35–41, April 2006.
- [30] S. Ergen and P. Varaiya, "Energy efficient routing with latency guarantee for sensor networks," *ACM Wireless Networks*, to be published.
- [31] N. Boughanmi and Y. Q. Song, "A new routing metric for satisfying both energy and delay constraints in wireless sensor networks," *The Journal of VLSI Signal Processing*, 2007.
- [32] B. Nefzi and Y. Q. Song, "Performance analysis and improvement of Zigbee routing protocol," *IFAC FET*, pp. 199–206, November 2007.

- [33] Y. Hu, N. Yu, and X. Jia, "Energy efficient real-time data aggregation in wireless sensor networks," in *Proc. IWCMC*, pp. 803–808, July 2006.
- [34] J. Zhu, S. Papavassiliou, and J. Yang, "Adaptive localized QoS-constrained data aggregation and processing in distributed sensor networks," *IEEE Trans. Parallel Distrib. Syst.*, vol. 17, no. 9, pp. 923–933, November 2006.
- [35] Y. Yu, V. Prasanna, and B. Krishnamachari, "Energy minimization for real-time data gathering in wireless sensor networks," *IEEE Trans. Wireless Commun.*, vol. 5, no. 11, pp. 3087–3096, November 2006.
- [36] T. He, L. Gu, L. Luo, T. Yan, J. Stankovic, T. Abdelzaher, and S. Son, "An overview of data aggregation architecture for real-time tracking with sensor networks," in *Proc. IEEE RTAS*, pp. 55–66, April 2006.
- [37] C. Lu, B. Blum, T. Abdelzaher, J. Stankovic, and T. He, "RAP: a real-time communication architecture for large-scale wireless sensor networks," in *Proc. IEEE RTAS*, pp. 55–66, September 2002.
- [38] A. Ruzzelli, G. O'Hare, M. O'Grady, and R. Tynan, "MERLIN: a synergetic integration of MAC and routing protocol for distributed sensor networks," in *Proc. IEEE SECON*, pp. 266–275, 2006.
- [39] J. Wu, P. Havinga, S. Dulman, and T. Nieberg, "Eyes source routing protocol for wireless sensor networks," in *Proc. EWSN*, 2004.
- [40] E. Ngai, M. Lyu, and J. Liu, "A real-time communication framework for wireless sensor-actuator networks," in *Proc. IEEE Aerospace Conf.*, March 2006.
- [41] T. He, B. M. Blum, Q. Cao, J. A. Stankovic, S. H. Son and T. F. Abdelzaher, "Robust and timely communication over highly dynamic sensor networks," in *Real-Time Systems Journal*, 2007.



Unité de recherche INRIA Lorraine
LORIA, Technopôle de Nancy-Brabois - Campus scientifique
615, rue du Jardin Botanique - BP 101 - 54602 Villers-lès-Nancy Cedex (France)

Unité de recherche INRIA Futurs : Parc Club Orsay Université - ZAC des Vignes
4, rue Jacques Monod - 91893 ORSAY Cedex (France)

Unité de recherche INRIA Rennes : IRISA, Campus universitaire de Beaulieu - 35042 Rennes Cedex (France)

Unité de recherche INRIA Rhône-Alpes : 655, avenue de l'Europe - 38334 Montbonnot Saint-Ismier (France)

Unité de recherche INRIA Rocquencourt : Domaine de Voluceau - Rocquencourt - BP 105 - 78153 Le Chesnay Cedex (France)

Unité de recherche INRIA Sophia Antipolis : 2004, route des Lucioles - BP 93 - 06902 Sophia Antipolis Cedex (France)

Éditeur
INRIA - Domaine de Voluceau - Rocquencourt, BP 105 - 78153 Le Chesnay Cedex (France)
<http://www.inria.fr>
ISSN 0249-6399