



**HAL**  
open science

## Image segmentation using Spiking Pixel Architecture

Amine Bermak, M. Hopfinger, Dominique Martinez

► **To cite this version:**

Amine Bermak, M. Hopfinger, Dominique Martinez. Image segmentation using Spiking Pixel Architecture. Special session on Next Generation Image Sensors for Multimedia applications - SCI'2002, Jul 2002, Orlando, Florida, USA, 5 p. inria-00107570

**HAL Id: inria-00107570**

**<https://inria.hal.science/inria-00107570>**

Submitted on 19 Oct 2006

**HAL** is a multi-disciplinary open access archive for the deposit and dissemination of scientific research documents, whether they are published or not. The documents may come from teaching and research institutions in France or abroad, or from public or private research centers.

L'archive ouverte pluridisciplinaire **HAL**, est destinée au dépôt et à la diffusion de documents scientifiques de niveau recherche, publiés ou non, émanant des établissements d'enseignement et de recherche français ou étrangers, des laboratoires publics ou privés.

# Image Segmentation using a Spiking Pixel Architecture

A. Bermak, M. Hofinger (†) and D. Martinez (‡)

†School of Engineering and Mathematics

Edith Cowan University,

Perth, WA 6027, Australia.

‡LORIA-CNRS Campus Scientifique,

Vandoeuvre-Les-Nancy, 54506, France.

## Abstract

This paper describes a spiking pixel architecture that can be used in a locally interconnected network in order to perform image capture as well as image segmentation. In this network, interaction between pixels can be locally obtained and is mediated via the discharge speed of each spiking pixel. The paper studies three different architecture of locally coupled pixels and shows that synchronisation of two coupled pixels can be obtained using only local excitation schemes. A theoretical condition for synchronisation was also deduced and which confirms the obtained simulation results. The proposed schemes were also successfully tested for a set of noisy gray scale images.

**keywords:** Image Segmentation, Spiking Pixel, VLSI.

## 1 Introduction

Image processing such as object segmentation and extraction are very important processing steps of next generation vision systems. The hardware implementation of such systems implies implementing photodetectors together with complex image processing circuitry. In order to design such systems at low cost and low power consumption, CMOS based architecture appears to be the most appropriate alternative. It has been extensively reported in the literature that CMOS technology is very suitable when it comes to implementing image processing together with the image capture device [1]. The standard approach to realize segmentation, in digital technology, is to scan the image sequentially into a digital memory, and then process the data sequentially using a digital processor. The processing also takes into account a

mask of neighboring pixels. As a result, a very large amount of data needs to be stored and processed at a very high speed. Special and novel CMOS architecture are therefore required in order to cope with real-time requirement and increasing imager resolutions.

Integrate and fire neurons are biologically inspired networks that have been extensively studied in the literature and have been successfully used for a number of applications including image segmentation [2]. Despite their ability to cope with real-time requirement and increasing resolution, most of the work related to integrate and fire neurons is limited to software implementation and simulation and very little work was reported on hardware implementation [3, 4].

In this paper, we first describe a pixel architecture referred to as "spiking Pixel". This pixel architecture is then used in a locally interconnected network in order to perform image capture as well as image segmentation. In this network, interaction between pixels can be locally obtained and is mediated via the discharge speed of each spiking pixel. This model is very close to the behaviour of integrate-and-fire oscillators which can be used for image segmentation when arranged in a Locally Excitatory Globally Inhibitory Oscillator Network (LEGION) [2]. In this paper we study different types of interaction between locally interconnected pixels and investigate if local excitation can lead to synchronization of adjacent pixels. The behaviour of a single pixel as well as a locally coupled array of pixel is presented in this paper. Section 2 presents the spiking pixel architecture. Section 3 describes a locally interconnected spiking pixels network used for segmentation. Three different architecture are presented and their ability to perform segmentation is simulated and compared. Section 4 provides a conclusion and discusses the results.

## 2 Spiking Pixel

The principle behind the spiking pixel as proposed in [5] is shown in the block diagram of Figure 1. A single pixel consists of a photodiode  $P_d$  with its internal capacitor  $C_d$ , a reset transistor, a clocked comparator, a digital counter and a feedback circuit. The light falling onto the photodiode  $P_d$  is responsible for discharging the internal capacitor of the photodiode  $C_d$ . This results in a decreasing voltage  $V_d$  across the node of the photodiode as shown in Figure 2. This voltage is compared to a reference voltage  $V_{ref}$  using a clock triggered comparator. When the voltage  $V_d$  reaches the reference voltage  $V_{out}$  is switched high for half a clock cycle. This impulse is used to reset the photodiode and increment the value of the counter. Figure 2 shows the output voltage  $V_{out}$  of the comparator

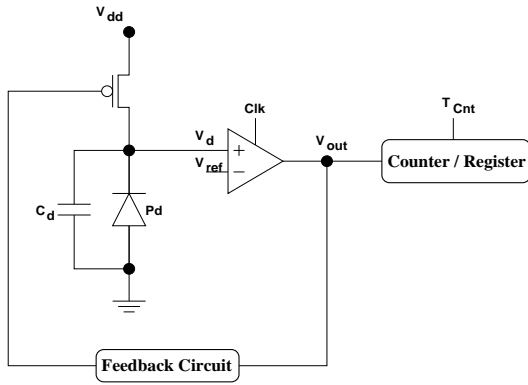

Figure 1: Block diagram of the spiking pixel.

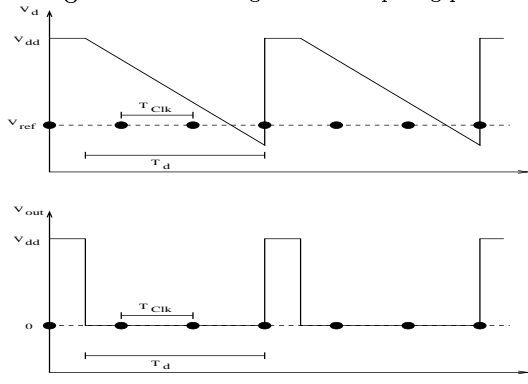

Figure 2: Voltages of the different nodes of the circuit.  $V_d$  is the voltage across the photodiode and  $V_{out}$  the output voltage of the comparator.

On Figure 2,  $T_d$  represents the discharge time of the capacitor which can be expressed by:

$$T_d = \frac{(V_{dd} - V_{ref}) \cdot C_d}{i_d} \quad (1)$$

Assuming that the clock frequency of the com-

parator is much higher compared to the inverse of the discharge time  $T_d$ , we can write that the frequency  $f$  of the voltage across the photodiode  $V_d$  is inversely proportional to  $T_d$  and therefore can be expressed as:

$$f \approx \frac{1}{T_d} = \frac{i_d}{(V_{dd} - V_{ref}) \cdot C_d}$$

The photocurrent  $i_d$  is directly proportional to the illumination level  $Il$  and can be expressed as:

$$i_d = \frac{Il \cdot A \cdot wpl}{E_{ph}} \cdot \eta \cdot q$$

$Il$  is expressed in lux,  $A$  is the area of the diode and  $wpl$  is the 'watts per lumen' constant which depends, together with the energy of one photon  $E_{ph}$ , on the wavelength. Finally,  $\eta$  is the quantum efficiency of the diode and  $q$  is the charge of an electron. The following assumptions are made for further calculations:

- The light falling onto the photodiode has an average wavelength of 555nm so  $wpl$  and  $E_{ph}$  become constants.
- The value of the capacitance  $C_d$  is independent of the momentary value of  $V_d$ . Simulations show that the discharge time  $T_d$  of the photodiode would vary by only 0.5% when taking  $V_d$  into consideration. For our case the value of  $C_d$  is approximated at 277 fF.

## 3 Segmentation using locally interconnected SPA

In order to achieve image segmentation a locally interconnected spiking pixel network is used. In this network interaction from one pixel to a mask of neighboring pixels is mediated via the discharge speed of each spiking pixel. Figure 3 shows a block diagram of a pair of coupled spiking pixels: If the potential of one pixel drops below the reference voltage it will generate a pulse at the comparator output and will reset the pixel. This is referred to as *firing state*. An instantaneous excitation impulse is sent to the adjacent pixel which is forced by a current impulse  $i_{pulse}$  to increase its slope for half a clock cycle. This corresponds to a certain voltage drop  $\Delta V$  which is independent of the actual potential of that pixel since the discharge function is linear.

$$\Delta V = \frac{i_{pulse}}{2 \cdot C_d \cdot f_{clk}} \quad (2)$$

If this voltage drop decreases the potential of the excited pixel below the reference voltage, the excited pixel will fire as well. The effect of coupling

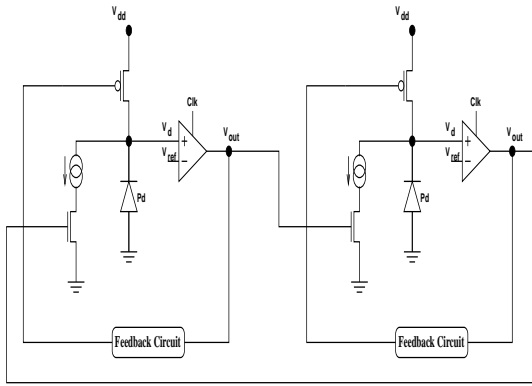

Figure 3: block diagram of a pair of spiking pixels

two pixels using a controlled current source as represented in Figure 3 has been simulated for different levels of illuminations and for different coupling strength. Figure 4 shows the synchronization ability of two pixels at different illuminations and excitation strengths. On the top of Fig. 4, the z-axis displays the number of unsynchronized cycles, thus the lower the value the faster the synchronization will occur. In these simulations 200 cycles were simulated for each pair of parameters. Pixel 1 received a constant illumination of 550 lx while the illumination of pixel 2 is varied between 450 lx and 650 lx. Area A corresponds to the case where the pixels synchronize, but only after a high number of cycles. Area B corresponds to the case where the pixels are synchronized within a couple of cycles. Finally, Area C corresponds to the case where the pixels do not synchronize at all because the excitation strength is too weak. This happens in the case where the voltage drop  $\Delta V$  due to excitation is less than the diode with the higher illumination is able to catch up in one discharging period of the slower diode. Using Eq.(2) we derive:

$$\frac{Il_1}{V_{dd} - V_{ref}} = \frac{Il_2}{V_{dd} - V_{ref} - \Delta V}$$

Thus, in order to achieve synchronization, the excitation pulse must cause a minimal voltage drop of:

$$\Delta V = (V_{dd} - V_{ref}) \cdot \left(1 - \frac{Il_2}{Il_1}\right) \quad (3)$$

This theoretical model is represented on Figure 5 which matches perfectly with the simulation results of Figure 4.

An interesting fact about this way of synchronization is that it takes longer the closer the illuminations of the pixels are because the slopes differ only slightly and hence it takes more time for the synchronization to occur.

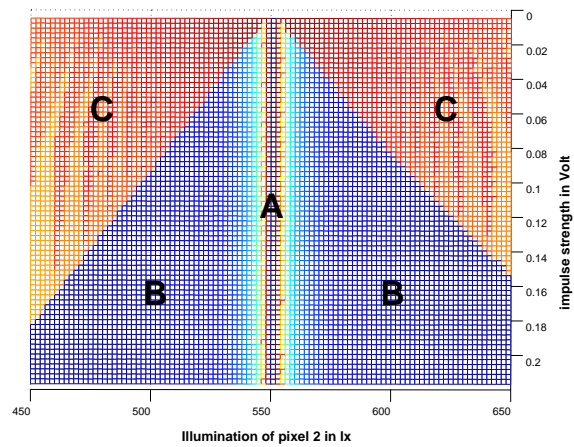
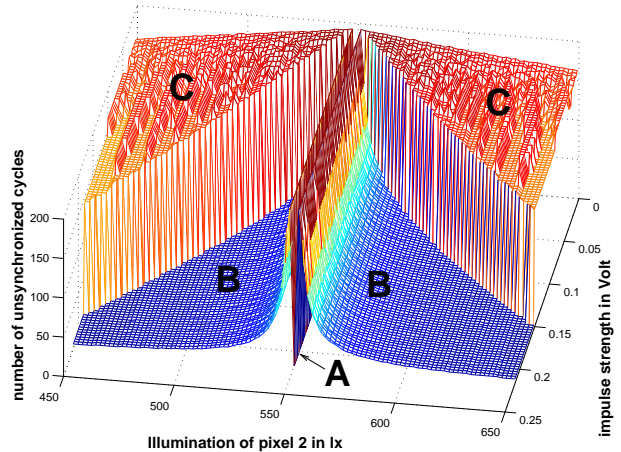

Figure 4: The top figure shows synchronization ability of two pixels at different illuminations and excitation strengths. The x-axis, y-axis and z-axis represent illumination of diode 2, excitation strength and the number of unsynchronized cycles respectively. Bottom figure shows a top view of the 3D-plot

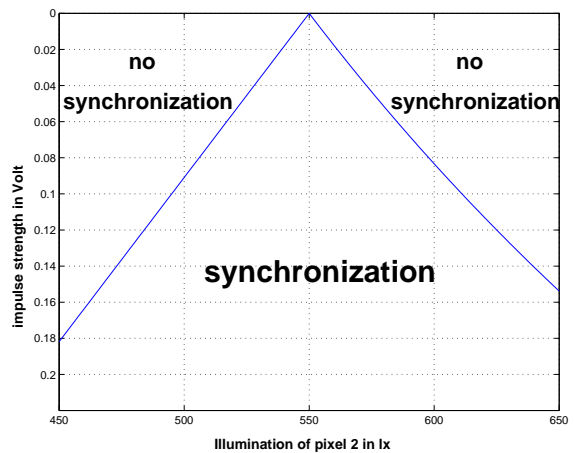

Figure 5: Theoretical results for the synchronization region derived from Eq. (3). As it can be seen from this figure the theoretical results match perfectly the simulation.

Although it is possible to synchronize a pair of pixels using the architecture shown in Figure 3, the procedure is not satisfying because (i) synchronization takes longer the closer the illuminations are and the synchronized state is very unstable against variations in the illumination and supply voltage. Our proposed strategy for coupling two adjacent pixels has fundamental differences with integrate-and-fire oscillators justifying the poor segmentation performance. The Wang’s model of integrate-and-fire oscillators presents an infinite propagation speed. Thus an oscillator that is induced to fire is reset at the very same moment so it is not able to re-affect the inducing oscillator. In this model one oscillator could start a chain reaction to synchronize an entire network in just one cycle if all oscillators are close enough to the threshold. Unfortunately in our real-time model an excited pixel can only fire at the next clock cycle and therefore excite the inducing pixel again. We could get rid of this problem by holding a pixel at  $V_{dd}$  for one more clock cycle after firing before releasing it to discharge again. An immediate re-excitation is no longer possible which leads to the simulation results shown in Figure 6. A pair of pixels synchronizes either immediately if the excitation is strong enough or it never does. Figure 6 shows the obtained results for such a system. In this new architecture, two coupled pixels either synchronize within one cycle (area B) or they never synchronize (area C). Area B corresponds now to the areas A and B of Figure 4.

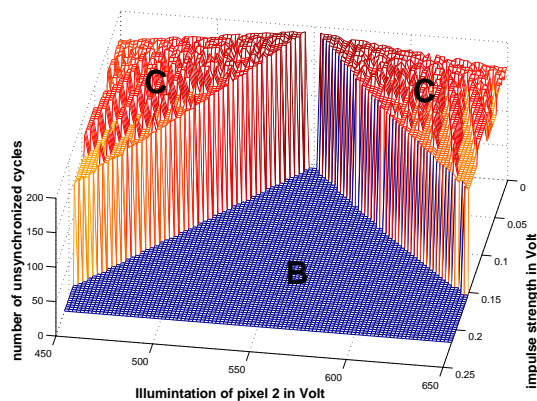

Figure 6: Synchronisation ability of two coupled pixels using the procedure of holding the pixel at  $V_{dd}$  after firing for one more clock cycle.

It must be noted that in Wang’s LEGION model the discharge curve follows an exponential trajectory instead of the linear discharge function of our spiking pixel. This exponential behavior has an additional synchronizing effect since the excitation impulse causes a stronger impact on a

pixel that is close to the threshold than on a pixel that is still far away from  $V_{ref}$ . We can take this important aspect into consideration in our spiking pixel by adapting the excitation strength according to the actual potential of the excited pixel as shown in Fig. 7. The adaptive excitation strength was also simulated for two coupled pixels and the results were very similar to these obtained in Fig. 6.

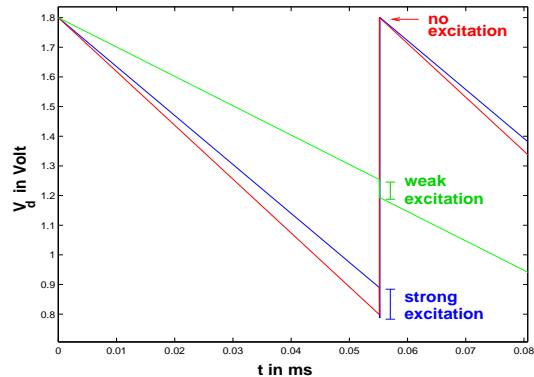

Figure 7: Adaptive excitation strength process. No re-excitation occur in this system since the potential of the pixel is set to  $V_{dd}$  after firing which has a null excitation effect on the neighboring pixel.

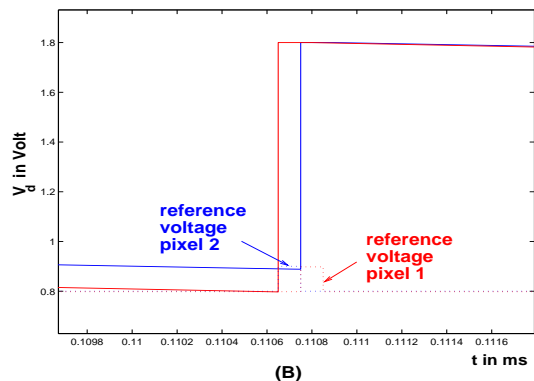

Figure 8: Synchronization of a pair of pixels by changing the reference voltage during excitation.

A fully different way of carrying out the excitation is to change the reference voltage of an excited pixel instead of sending a current pulse to the neighboring pixel. The reference voltage of an excited pixel is increased by a voltage corresponding to Eq.(3). A pixel that is close enough to the threshold will therefore fire at the following clock cycle but the excitation will not have any effect on a pixel that is far away from the threshold. Figure 8 shows the principle behind such a system. The synchronization by changing the reference voltage was also simulated for two coupled pixels and the results were very similar to these shown in Fig. 6.

## 4 Conclusions and discussions

In this paper a spiking pixel architecture used for image segmentation is presented. We first describe the pixel and we propose a scheme for locally interconnected network of pixels. In this network, interaction between pixels can be locally obtained and is mediated via the discharge speed of each spiking pixel. Simulation results for locally coupled pixels are presented. Three improvement of the current mode architecture were proposed and simulated. Results showed that it is possible to tune the segmentation ability by varying the excitation strength which corresponds to either a discharge current or to the reference voltage. We have also deduced a theoretical condition for obtaining the synchronization of two pixels and which confirms very strongly the obtained simulation results. We also simulated the synchronization ability of an array of pixels using all the proposed schemes. It was found that an entire array of pixels can be synchronized by choosing an excitation strength according to the theoretical model proposed in Eq. (3). The proposed schemes were also tested for a set of noisy gray scale images and it was found that the method of adapting the excitation strength and the method of changing the reference voltage both give very good results. The proposed schemes presents the advantage of simple VLSI implementation which make them very suitable for future smart vision systems application.

## Acknowledgments

The authors would like to thank the Australian Research Council for supporting this research project. Thanks are also due to A.Prof A. Bouzerdoum for helpful discussions.

## References

- [1] E. R. Fossum, "CMOS image sensors: electronic camera-on-a-chip", IEEE transactions on electron devices, Vol. 44 no.10, pp.1689–1696, 1997.
- [2] S. R. Campbell, D. L. Wang and C. Jayaprakash, "Synchrony and Desynchrony in Integrate-and-Fire Oscillators", Neural Computation, no.11, pp.1595–1619, 1999.
- [3] J. Cosp, J. Madrenas and J. Cabestany, "A VLSI Implementation of a Neuromorphic Network for Scene Segmentation", Proceedings of

IEEE International Conference on Microelectronics for Neural, Fuzzy and Bio-Inspired Systems, MicroNeuro'99, pp.403–408, Granada, Spain 1999.

- [4] G. Crebbin, M. Fajria, "Integrate-and-Fire Models for Image Segmentation", Proceedings of SPIE Conference on Visual Communications and Image Processing VCIP'00, Vol. 4067, pp.867–874, Perth, Australia 2000.
- [5] A. Bermak, "A CMOS imager with PFM/PWM Based Analog-to-Digital Converter", To appear in the Proceedings of the IEEE International Symposium on Circuits and Systems, ISCAS02, Phoenix, USA, May 2002.