



HAL
open science

Further numerical methods for the Faulkner Skan equations: Shooting and continuation techniques

C. Laine, L. Reinhart

► **To cite this version:**

C. Laine, L. Reinhart. Further numerical methods for the Faulkner Skan equations: Shooting and continuation techniques. RR-0177, INRIA. 1983. inria-00076381

HAL Id: inria-00076381

<https://inria.hal.science/inria-00076381>

Submitted on 24 May 2006

HAL is a multi-disciplinary open access archive for the deposit and dissemination of scientific research documents, whether they are published or not. The documents may come from teaching and research institutions in France or abroad, or from public or private research centers.

L'archive ouverte pluridisciplinaire **HAL**, est destinée au dépôt et à la diffusion de documents scientifiques de niveau recherche, publiés ou non, émanant des établissements d'enseignement et de recherche français ou étrangers, des laboratoires publics ou privés.

IRIA

CENTRE DE ROCQUENCOURT

Institut National
de Recherche
en Informatique
et en Automatique

Domaine de Voluceau
Rocquencourt
BP 105
78153 Le Chesnay Cedex
France
Tél 954 90 20

Rapports de Recherche

N° 177

**FURTHER
NUMERICAL METHODS
FOR THE FALKNER SKAN
EQUATIONS :
SHOOTING AND CONTINUATION
TECHNIQUES**

**Claudine LAINE
Laure REINHART**

Janvier 1983

FURTHER NUMERICAL METHODS FOR THE FALKNER SKAN EQUATIONS :
SHOOTING AND CONTINUATION TECHNIQUES.

Claudine LAINE, Laure REINHART

RÉSUMÉ

On considère dans cet article la résolution numérique de l'équation différentielle de Falkner Skan, modélisant, sous des hypothèses de similarité les équations de la couche limite. On cherchera ici les solutions extrémales de cette équation différentielle du 3ème ordre. Les méthodes utilisées sont essentiellement des méthodes de Newton et de tirs, qui, couplées avec des méthodes de continuation permettent le suivi systématique des arcs de solutions contenant des points réguliers ou de retournement.

ABSTRACT

We consider in this paper the numerical solution of the Falkner Skan differential equation, modelling under some similarity assumptions the boundary layer equation. We look for the extremal solution of this third order differential equation. The methods we use are basically the Newton method with a shooting process, which is coupled with a continuation method : they allow us to follow the solution arcs which contain regular and turning point solutions.



INTRODUCTION

The Falkner Skan equation is obtained from the dimensionless Prandtl's equations, in which is introduced a similarity assumption. It consists in a non linear third order differential equation :

$$\left\{ \begin{array}{l} f''' + f f'' + \beta(1 - f'^2) = 0, \\ f(0) = f'(0) = 0, \\ f'(\infty) = 1. \end{array} \right.$$

We study numerically the solutions of this equation, satisfying the initial condition :

$$f''(0) = \alpha.$$

The solutions can be then characterized by their positions in the plane (α, β) .

In section 2, a Newton method associated with a shooting process is used to find the regular solutions.

The introduction of the continuation equation, which consists of an arclength constraint, allows us to treat simple turning points as regular solutions of the new problem. It is then quite easy to follow the arcs of solution containing regular and turning point solutions.

Section 4 presents numerical experiments.

1.1. - The Falkner Skan equations - Theoretical results

In this section, we present the governing boundary layer equations, in the physical (x,y) plane. They correspond to a first order approximation of the incompressible Navier-Stokes equations in dimension 2. More precisely, the dimensionless Prandtl's boundary layer equations can be written as follows :

$$(1.1) \quad \begin{cases} u \frac{\partial u}{\partial x} + v \frac{\partial u}{\partial y} = -\frac{\partial p}{\partial x} + \frac{\partial^2 u}{\partial x^2}, & \text{in } \Omega, \\ \frac{\partial p}{\partial y} = 0, & \text{in } \Omega = \{(x,y) ; x > 0, y > 0\}. \end{cases}$$

Here p is the pressure, and (u,v) is the velocity field (referred to the external velocity $u_\infty(x)$) which satisfies the continuity equation :

$$(1.2) \quad \frac{\partial u}{\partial x} + \frac{\partial v}{\partial y} = 0.$$

The boundary conditions are given by natural conditions at the wall, i.e. for $y = 0$, and by matching with the external flow :

$$(1.3) \quad \begin{cases} u(x,0) = 0, \\ v(x,0) = v_{\text{wall}}(x), \\ u(x,\infty) = u_\infty(x). \end{cases}$$

An initial condition is given by :

$$(1.4) \quad u(0,y) = \psi(y),$$

we introduce next a similarity condition [26] having physical meaning in the special case of incompressible flow :

$$u(x,y) = u_\infty(x) \psi(\eta),$$

$$\eta = \frac{y}{g(x)},$$

where g is determined in the following. Then $\{x,\eta\}$ defines a new set of independent variables.

Let us express $v(x,y)$ by integrating the continuity equation (1.2), with $v_{\text{wall}} \equiv 0$:

$$v(x,y) = -g(x) u'_\infty(x) f(\eta) + u_\infty(x) g'(x) (\eta \psi(\eta) - f(\eta))$$

with :

$$f(\eta) = \int_0^\eta \psi(\theta) d\theta.$$

Taking into account in (1.1) the similarity assumption leads to the equation :

$$-ff'' + \frac{g u_\infty'}{g' u_\infty} (f'^2 - 1 - ff'') = \frac{\nu}{u_\infty g g'} F''' ,$$

where ν is the kinematic viscosity, and in which the function $f'(\eta)$ constitutes a dimensionless form of the longitudinal velocity component in the boundary layer, referred to the external velocity u_∞ . The function $f(\eta)$ is then proportional to the local boundary layer thickness.

Since f depends only on η , and since g and u_∞ depend only on x , we obtain :

$$(1.5) \quad \frac{g u_\infty'}{g' u_\infty} = a = \text{constant},$$

and :

$$(1.6) \quad u_\infty g g' = b = \text{constant}.$$

Equation (1.5) implies :

$$u_\infty = k_1 g^a,$$

so equation (1.6) becomes :

$$g^{a+2} = k_2 x + c_0.$$

Finally, with a translation of origin (i.e. $c_0 = 0$), we get :

$$\begin{cases} u_\infty(x) = k_1 g^a(x), \\ g(x) = k_2 x^{(1/a+2)}. \end{cases}$$

Let us define m by :

$$(1.7) \quad m = \frac{a}{a + 2},$$

we get then :

$$\begin{cases} u_{\infty}(x) = k_3 x^m, \\ g(x) = k_2 x^{\frac{1-m}{2}} = k_4 \sqrt{\frac{x}{u_{\infty}(x)}}. \end{cases}$$

The constant k_3 depends on the external velocity $u_{\infty}(x)$. It is convenient to make the following choice of k_4 :

$$(1.9) \quad k_4 = \frac{2v}{1+m}.$$

Finally, the boundary layer equations are transformed into the following differential equation, with respect to the variable η :

$$(1.10) \quad f''' + ff'' + \beta(1 - f'^2) = 0.$$

The parameter β is defined by :

$$(1.11) \quad \beta = \frac{2m}{m+1},$$

and plays a fundamental role. In a mathematical sense, it may take any real value, and can be considered as a "bifurcation" parameter. Note that the solution in the special case $\beta = 0$ is called the Blasius solution.

Finally, the boundary conditions associated with (1.10) are :

$$(1.12) \quad \begin{cases} f(0) = f'(0) = 1, \\ f'(+\infty) = 0. \end{cases}$$

1.2. - Basic results

Equations (1.10) and (1.12) were first introduced by Falkner and Skan in 1931 [7]. One of the earliest studies, due to Hartree in 1937 [12] gave the additional condition :

$$\forall t \geq 0, 0 \leq f'(t) \leq 1,$$

in order to preserve a physical meaning.

First, it is convenient to define precisely the different types of solutions of the Falkner-Skan equations which have appeared in the literature (see the discussion in [2]).

1.2.1. - Definitions

Definition 1.1. : A classical solution of (1.10), (1.12) is one for which $f'(t) > 0$ for $t > 0$.

Definition 1.2. : A reverse flow solution of (1.10), (1.12) is one for which there exists a $\tau > 0$ such that $f'(\tau) < 0$.

Definition 1.3. : An overshoot solution of (1.10), (1.12) is a reverse flow solution for which there exists a τ such that $|f'(\tau)| > 1$.

1.2.2. - Solutions without overshoot

There are two cases to consider according to the sign of β , i.e. if there is an adverse pressure gradient or not.

1.2.2.1. - The case $\beta \geq 0$

Weyl [28] established the existence of a classical solution for β fixed (see Hartman [10] for details). Global uniqueness holds only for $0 \leq \beta \leq 1$ in which case $f'(t) > 0$ whenever $t > 0$ [15], [6]. For $\beta = 0$, the Blasius solution (without pressure gradient) corresponds to the unique value of α such that $\alpha \approx 0,49$, where $\alpha = f''(0)$.

1.2.2.2. - The case $\beta < 0$

For $\beta^* < \beta < 0$, there exists an infinite number of solutions, bounded by two extremal solutions. $\beta^* = -0.198838 \pm 10^{-6}$ is a turning (bending) point where the extremal solutions coincide. The upper (i.e. $f''(0) \geq 0$) extremal solution is a classical one with $f'(t) \rightarrow 1$ exponentially [11]. The lower (i.e. $f''(0) \leq 0$) extremal solution was first obtained by Stewartson [25] and investigated by Hastings [13]; it is of

the reverse flow type, with $f'(t) \rightarrow 1$ exponentially. All solutions between the extremal ones are characterized by an algebraic convergence of $f'(t) \rightarrow 1$.

The minimal extremal branch ends at $\beta = 0$ which is a singular limit point (see Brown and Stewartson [4]).

1.2.2.3. - The turning point β^*

The value β^* has been computed numerically by Stewartson [24] and its existence has been discussed by Iglisch and Kemnitz [15]. In a physical sense, the point $(\beta^*, \alpha^* = 0)$ links reverse flow solution branches and solutions branches without separation in the (α, β) plane.

Heuristically, β^* is a turning point in the following sense : for $\beta > \beta^*$, locally there exists two extremal branches of solution, and for $\beta < \beta^*$ there is locally no extremal solution. Banks and Drazin [1] have initiated a local study near $\beta = \beta^*$. A continuation process has allowed us to follow the branch of classical solutions, especially through the turning point.

1.2.3. - Overshoot solutions

For $\beta < \beta^*$, Stewartson has shown that all possible solutions are of the overshoot type. Numerical studies have pointed out branches of overshoot solutions. The solutions of the branch labelled n , present n extrema as well as n overshoots ; the number of overshoots is defined precisely as the number of zeros of the equation $f'-1 = 0$.

Libby and Liu [14] calculated some of these branches. The last point they found for the first branch was $\beta = -1.0060$ and $f''(0) = -1.09$. For this solution, f' has exponential decay. So it does seem (numerically) that the first branch with overshoot ends at $\beta = -1$. The last point that Libby and Liu found for the second branch with overshoot was $\beta = -1.9458$, $f''(0) = -1.47$.

Following this idea, we calculated numerically some branches of extremal solutions. The numerical analysis that we did leads to a precise knowledge of seven branches, as well as their behavior as β goes to -1 .

Some theoretical insight has been given by Troy [27] who established the existence of an infinite sequence of negative β_j for which there exist solutions with j overshoots and exponential convergence of $f' \rightarrow 1$.

2. - NUMERICAL METHODS WITHOUT CONTINUATION PROCESS

2.1. - Statement of the problem

We are interested here in the numerical solution of the initial value problem :

$$(S_\alpha) \begin{cases} f''' + ff'' + \beta(1-f'^2) = 0, \\ f(0) = f'(0) = 0, \\ f''(0) = \alpha, \end{cases}$$

and we are seeking the solutions f of (S_α) satisfying the so called extremal condition (see section 1.2.2.2) :

$$(2.1) \quad \lim_{\eta \rightarrow +\infty} f'(\eta) = 1,$$

which amounts specifying an admissible domain for α .

2.1.1. - Solutions of System (S_α), satisfying (2.1)

System (S_α) is equivalent to a first order differential system namely :

$$\text{Find } \{y_1, y_2, y_3\} \text{ in } (C^0(\mathbb{R}^+))^3$$

such that :

$$(2.2) \quad \begin{cases} \dot{y}_1 = y_2, \\ \dot{y}_2 = y_3, \\ \dot{y}_3 = -y_1 y_3 - \beta(1-y_2^2), \end{cases}$$

with the initial condition :

$$(2.3)_\alpha \quad y_1(0) = 0, y_2(0) = 0, y_3(0) = \alpha.$$

Among the possible solutions of (2.2), (2.3)_α, we shall select the solutions $Y_\alpha = \{y_{1,\alpha}, y_{2,\alpha}, y_{3,\alpha}\}$, for which the extremal criterium is satisfied, namely those belonging to the kernel of the linear operator G, defined by :

$$G(Y) = y_2(\infty) - 1.$$

Remark : In practice, for the numerical study, we shall replace the operator G by :

$$(2.4) \quad G(Y) = y_2(A) - 1,$$

with $A \gg 1$.

Define next a non linear mapping $F : \mathbb{R} \rightarrow \mathbb{R}$ by :

$$(2.5) \quad \alpha \rightarrow F(\alpha) = y_{2,\alpha}(A) - 1$$

where $Y_\alpha = \{y_{1,\alpha}, y_{2,\alpha}, y_{3,\alpha}\}$ is a solution of system (2.2) corresponding to the initial condition (2.3) $_\alpha$.

Then solving S_α , taking into account the condition (2.1), is equivalent to finding the roots of F in \mathbb{R} , namely to solving in \mathbb{R} the equation :

$$(2.6) \quad F(\alpha) = 0.$$

This last equation can be solved by a Newton's method : if the derivative of F with respect to α does not vanish at a root α^* of F , the sequence α_k defined by :

$$(2.7) \quad \alpha_{k+1} = \alpha_k + (F'(\alpha_k))^{-1} F(\alpha_k),$$

converges to α^* , if α_0 belongs to a sufficiently small neighbourhood of α^* .

In our case, the sequence $\{\alpha_k\}_k$ may be constructed by the following :

$$(2.8) \quad \alpha_{k+1} = \alpha_k - (y_{2,\alpha_k}(A) - 1) / \frac{\partial}{\partial x_k} (y_{2,\alpha_k}(A)).$$

In addition, by the existence theorem of Peano, if Y is a solution of the differential system :

$$\dot{Y} = \mathcal{F}(Y) \quad \text{and} \quad Y(0) = (0, 0, \alpha)^T,$$

then $\frac{\partial Y}{\partial \alpha}$ is a solution of the first order differential system :

$$\dot{X} = \text{Jac}(\mathcal{F}) X, \quad \text{with the initial condition} \\ X(0) = (0, 0, 1)^T,$$

where $\text{Jac}(\mathcal{F})$ denotes the jacobian matrix of \mathcal{F} .

Using this property we can write $\frac{\partial}{\partial \alpha_k}(y_{2,\alpha}(A))$ as :

$$\frac{\partial}{\partial \alpha_k} (y_{2,\alpha_k}(A)) = \left(\frac{\partial}{\partial \alpha_k} y_{2,\alpha_k} \right) (A) = x_{2,\alpha_k}(A),$$

where :

$$\dot{x}_{\alpha_k} = \begin{pmatrix} \dot{x}_{1,\alpha_k} \\ \dot{x}_{2,\alpha_k} \\ \dot{x}_{3,\alpha_k} \end{pmatrix} = \begin{pmatrix} x_{2,\alpha_k} \\ x_{3,\alpha_k} \\ -x_{1,\alpha_k} \cdot y_{3,\alpha_k} - y_{1,\alpha_k} x_{3,\alpha_k} + 2\beta y_{2,\alpha_k} \cdot x_{2,\alpha_k} \end{pmatrix}$$

with the initial conditions :

$$\begin{cases} x_{1,\alpha_k}(0) = 0, \\ x_{2,\alpha_k}(0) = 0, \\ x_{3,\alpha_k}(0) = 1. \end{cases}$$

2.1.2. - Extremal solutions : numerical treatment

The notion of extremal solutions was introduced for the Falkner Skan equation by Hartree [12]. He proposed considering extremal solutions for $\beta^* < \beta < 0$ only ; they can be connected then to the unique solution for $\beta \geq 0$; this will also ensure the continuity of the set of the solutions in the plane $(\beta, f''(0))$, in a neighbourhood of zero. In practice this asymptotic behavior may be characterized by the property : $f' \rightarrow 1$ exponentially.

In 1953, Stewartson [24] proposed to refine Hartree criterium by considering the solutions defined by :

$$f = \lim_{A \rightarrow +\infty} f_A$$

where f_A is a solution of the Falkner Skan equation satisfying the initial conditions added to the final condition :

$$f_A(0) = 0, \quad f'_A(0) = 0, \quad f'_A(A) = 1 \quad \text{for } A < \infty.$$

With this approach, Stewartson rediscovered the reattached flows of Hartree for $\beta^* < \beta$, and showed the existence of a branch of separated solutions for β in the same domain.

We call any solution which converges to 1 exponentially at infinity an extremal solution. Their main interest is that they correspond to physically stable solutions. In practice, we characterize these extremal solutions by the exponential decay of $F(\alpha)$ with respect to A , where F is defined through (2.6).

An extremal solution will then minimize with respect to α the quantity :

$$\Delta_\alpha = (y_{2,\alpha}(A) - 1)^2 = F^2(\alpha) ;$$

the scale factor α corresponding to extremal solutions will maximize $\frac{\partial \Delta_\alpha}{\partial \alpha}$ and can be characterized by :

$$(2.9) \quad \begin{cases} F(\alpha) = 0, \\ \frac{\partial}{\partial \alpha} \left(\frac{\partial F}{\partial A} \right)_\alpha = 0. \end{cases}$$

The second condition is a maximization criterium without constraint (α belongs to the whole real line) ; this criterium can be applied only if the first condition is satisfied. Conversely, if only the first criterium is satisfied, there exists a root α of F , by the asymptotic behavior of the solution will be "almost algebraic" (see [12]).

System (2.9) can moreover be written as :

$$\begin{cases} F(\alpha) = 0, \\ \frac{\partial}{\partial \alpha} (y_{3,\alpha}(A)) = 0. \end{cases}$$

2.2. - Numerical method

We shall now discuss a general method for the numerical search for extremal solutions of the Falkner Skan equation.

The method is a shooting method, called the adjoint method. For a given value of $f''(0)$, we integrate the Falkner Skan system (S_α) ; this computation provides a value of f' at the final abscissa A ; a test is then made to compare this last value with 1; if the difference $f'(A)-1$ is too large, a correction is made on $f''(0)$.

2.2.1. - The adjoint method : review

Let us consider the general differential system :

$$(2.10) \quad \dot{y}_i = g_i(y_1, y_2, \dots, y_n, t), \text{ for } i = 1, \dots, n,$$

where :

y_i belongs to $\mathcal{C}^1(\mathbb{R})$,
 g_i belongs to $\mathcal{C}^1(\mathbb{R}^n)$, with the boundary conditions :

$$(2.11) \quad \begin{cases} y_i(t_0) = c_i, & i = 1, \dots, r, \\ y_{n+1-m}(t_f) = c_{n+1-m}, & m = 1, 2, \dots, n-r. \end{cases}$$

Using a Taylor expansion, we obtain from (2.10) the linear variational system :

$$\delta \dot{y}_i = \sum_{j=1}^n \frac{\partial g_i}{\partial y_j} \cdot \delta y_j, \quad i = 1, \dots, n,$$

which has as adjoint system :

$$(2.12) \quad \dot{x}_i = - \sum_{j=1}^n \frac{\partial g_j}{\partial y_i} x_j.$$

Then we obtain the condition :

$$(2.13) \quad \sum_{i=1}^n (x_i(t_f) \delta y_i(t_f) - x_i(t_0) \delta y_i(t_0)) = 0,$$

which connects the adjoint and variational systems.

The adjoint method is an iterative method on $y_i(t_0)$ for $i = r+1$ to n ; let $y_i^{(k)}(t_0)$ be the value of y_i at the k^{th} iteration, at the value t_0 , the solution $y_i^{(k)}$ satisfies :

$$\dot{y}_i^{(k)} = g_i(y_1^{(k)}, y_2^{(k)}, \dots, y_n^{(k)}, t),$$

where $y_i^{(k)}(t_0)$ is known for $i = 1$ to n .

With the help of a numerical integration method, we determine the final values $y_i^{(k)}(t_f)$; then we compute :

$$\delta y_{i_m}^{(k)}(t_f) = c_{i_m} - y_{i_m}^{(k)}(t_f), \text{ for } m = 1 \text{ to } n-r.$$

In order to compute $\delta y_i^{(k)}(t_0)$ for $i = r+1$ to $i = n$, we shall integrate $(n-r)$ times the adjoint system (2.12) with the condition (2.13); the values $\delta y_i^{(k)}(t_0)$ are the solutions of the linear system on the interval (t_f, t_0) (backwards integration) :

$$(2.14) \quad \begin{cases} \dot{x}_i = \sum_{j=1}^n \frac{\partial g_i}{\partial y_j} x_j, \text{ for } i = 1, \dots, n-r, \\ x_i^{(m)}(t_f) = \delta_{i, i_m}, \delta_{i, j} \text{ is the Kroneker symbol.} \end{cases}$$

The condition (2.13) enables us to write :

$$\sum_{i=r+1}^n x_i^{(m)}(t_0) \delta y_i^{(k)}(t_0) = \delta y_{i_m}^{(k)}(t_f), \quad m = 1, \dots, n-r.$$

We then obtain the following system :

$$(2.15) \quad \begin{bmatrix} \delta y_{r+1}(t_0) \\ \delta y_{r+2}(t_0) \\ \vdots \\ \delta y_n(t_0) \end{bmatrix}^{(k)} = \begin{bmatrix} x_{r+1}^{(1)}(t_0) & x_{r+2}^{(1)}(t_0) & \dots & x_n^{(1)}(t_0) \\ \vdots & \vdots & \dots & \vdots \\ \dots & \dots & x_i^{(j)}(t_0) & \dots \\ \vdots & \vdots & \vdots & \vdots \\ x_{r+1}^{(n-r)}(t_0) & x_{r+2}^{(n-r)}(t_0) & \dots & x_n^{(n-r)}(t_0) \end{bmatrix} \cdot \begin{bmatrix} \delta y_{i_1}(t_f) \\ \delta y_{i_2}(t_f) \\ \vdots \\ \delta y_{i_{n-r}}(t_f) \end{bmatrix}^{(k)}$$

and as an initialization for the next integration, we take the value :

$$(2.16) \quad y_i^{(k+1)}(t_0) = y_i^{(k)}(t_0) + \delta y_i^{(k)}(t_0), \text{ for } i = r+1 \text{ to } i = n.$$

(see Roberts and Shipman [23]).

2.2.2. - Application to the Falkner Skan equation

We shall consider the canonical form of the system

(S_α), namely :

$$(2.17) \quad \begin{cases} \dot{y}_1 = y_2, \\ \dot{y}_2 = y_3, \\ \dot{y}_3 = -y_1 y_3 - \beta(1-y_2^2), \end{cases}$$

with the initial condition :

$$(2.18) \quad \begin{cases} y_1(0) = 0, \\ y_2(0) = 0, \\ y_3(0) = \alpha. \end{cases}$$

The corresponding variational system is :

$$(2.19) \quad \left. \begin{aligned} \begin{bmatrix} \delta \dot{y}_1 \\ \delta \dot{y}_2 \\ \delta \dot{y}_3 \end{bmatrix} &= \begin{bmatrix} 0 & 1 & 0 \\ 0 & 0 & 1 \\ -y_3 & 2\beta y_2 & -y_1 \end{bmatrix} \cdot \begin{bmatrix} \delta y_1 \\ \delta y_2 \\ \delta y_3 \end{bmatrix}, \\ \text{with :} \\ \begin{bmatrix} \delta y_1 \\ \delta y_2 \\ \delta y_3 \end{bmatrix} (0) &= \begin{bmatrix} 0 \\ 0 \\ 1 \end{bmatrix}, \end{aligned} \right\}$$

and the backward adjoint system is :

$$(2.20) \quad \left\{ \begin{array}{l} \begin{bmatrix} \dot{x}_1 \\ \dot{x}_2 \\ \dot{x}_3 \end{bmatrix} = \begin{bmatrix} 0 & 0 & -y_3 \\ 1 & 0 & 2\beta y_2 \\ 0 & 1 & -y_1 \end{bmatrix} \cdot \begin{bmatrix} x_1 \\ x_2 \\ x_3 \end{bmatrix}, \\ \text{with :} \\ \begin{bmatrix} x_1 \\ x_2 \\ x_3 \end{bmatrix} (A) = \begin{bmatrix} 0 \\ 1 \\ 0 \end{bmatrix} . \end{array} \right.$$

With the help of (2.13), (2.16) we obtain the relation :

$$(2.21) \quad y_3^{(k+1)}(0) = y_3^{(k)}(0) + (1 - y_2^{(k)}(A)) / x_3(0),$$

which define the iterative process.

The algorithm is stopped when the extremality criterium reaches a given accuracy. The integrations of the differential systems are approximated by a fourth order Runge-Kutta method.

2.2.4. - Performances of the method

The adjoint method allowed us to determine numerically the first seven branches of super solutions. This method is therefore effective, but it cannot be adapted to an automatic computation of the branches. Indeed, the natural progression along a constant path $\Delta\beta$ cannot be effective when the slope of the branches is large. The study of a branch has to be done point by point to adjust the path $\Delta\beta$ at each step of the computation. Numerically, it seems that all the branches with overshoots have the same singular limit point as β increases to -1 .

3. - CONTINUATION METHODS AND THEIR APPLICATIONS TO THE FALKNER SKAN EQUATIONS

The previous section discussed a method for finding individual solution of the Falkner Skan equations for a fixed β . In this section, we discuss methods for finding nearby solutions for different β to form solution branches. We describe two continuation methods for solving non linear problems and we show how these methods can be adapted to the numerical computation of branches of extremal solutions of the Falkner Skan equations. We show that these methods are well suited to bifurcation problems, especially to the computation of turning points.

3.1. - Solution of non linear problems

The approximated problems are to find, in some finite dimensional space, the solutions of the following problem :

$$(3.1) \quad F(u) = 0,$$

where F is a non linear operator defined on \mathbb{R}^n .

A general method, used to solve this kind of problem, is the well known Newton method ; it can be written in the case of differentiable F , as follows :

$$(3.2) \quad \begin{cases} u^0 \text{ given,} \\ u^{n+1} \text{ is computed from } u^n, \text{ by :} \\ \left\{ \begin{array}{l} F'(u^n) \cdot \delta u^n = -F(u^n) \\ u^{n+1} = u^n + \delta u^n. \end{array} \right. \end{cases}$$

This method can be easily implemented only in the special case where F' is invertible, for each u^n ; moreover it requires the computation and the inversion of the matrix $F'(u^n)$ at each step of the algorithm. Nevertheless it remains efficient and easy to use, in many cases ; in particular, if u^* is a simple root of (3.1), and, if u^0 is chosen in a suitable neighbourhood of u^* , the convergence of the sequence $\{u^n\}_n$ defined by (3.2) is quadratic.

We can also use least squares methods, which consist of minimizing a functional defined in \mathbb{R}^n , by :

$$(3.3) \quad J(u) = \|F(u)\|^2,$$

where $\|\cdot\|$ is a convenient norm on \mathbb{R}^n .

The problem (3.1) is then transformed into an optimization problem ; we can then use one of the numerous algorithms solving this kind of problem (see Polak [20], Periaux [19]).

We shall restrict ourselves to the case where F is of the form :

$$(3.4) \quad F(u) = Au - f(u),$$

where A is a linear, positive definite operator on \mathbb{R}^n ,
 f contains the non linear part of F .

In the optimal framework, the problem can be considered as a final observation on the solution of a non linear equation. In the case of the Falkner Skan problem, we have to minimize the extremality criterium.

Then problem (3.3) appears on the form of an optimal control problem (see Lions [18]) :

Minimize on \mathbb{R}^n , the functional :

$$v \rightarrow J(v) = \frac{1}{2}(A\xi, \xi),$$

where ξ is a function of the control variable, through the state equation :

$$(3.6) \quad A\xi = F(v) = Av - f(v).$$

It is clear that any solution u of (3.1) is a solution of the problem (3.5), and, conversely, if u is a solution of the minimization problem (3.5) satisfying $J(u) = 0$, then u is also a solution of (3.1).

To minimize J , we shall use a conjugate gradient algorithm. Among the possible conjugate gradient algorithms, we have selected the Polak-Ribière version (cf. Polak [20]), since this algorithm performed the best in the preliminary numerical tests we did. Its performance is discussed in Powell [21].

Let us denote by $J'(\cdot)$ the Frechet derivative of $J(\cdot)$; then, in the case of the model problem (3.4), this algorithm may be written as follows :

Step 1 : initialization

(3.7) u^0 given,

then compute g^0 , by :

(3.8) $Ag^0 = J'(u^0),$

and set :

(3.9) $z^0 = g^0.$

Then for $n \geq 0$, assuming u^n, g^n, z^n known, compute $u^{n+1}, g^{n+1}, z^{n+1}$ by :

Step 2 : Descent

(3.10) Compute $\rho^n = \text{Arg min}_{\rho \in \mathbb{R}} J(u^n - \rho z^n),$

(3.11) $u^{n+1} = u^n - \rho^n z^n.$

Step 3 : Construction of the new descent direction.

Define g^{n+1} by :

(3.12) $Ag^{n+1} = J'(u^{n+1}),$

then :

$$(3.13) \quad \gamma^{n+1} = \frac{(A(g^{n+1} - g^n), g^{n+1})}{(Ag^n, g^n)},$$

and set :

$$(3.14) \quad z^{n+1} = g^{n+1} + \gamma^{n+1} z^n,$$

$n = n+1$, go to (3.10).

The algorithm is stopped if, in (3.11), $J(u^{n+1})$ reaches a value less than a given (small) parameter ϵ .

In order to apply this algorithm to the Falkner Skan problem, steps (3.8) and (3.12) have to be modified.

3.2. - Continuation methods

3.2.1. - Statement of the problem

We shall consider a class of non linear problems depending upon a real parameter λ :

$$(3.15) \quad G(u, \lambda) = 0,$$

where $G : B \times \mathbb{R} \rightarrow \mathbb{R}$, and B is a Banach space (in practice, for the solution of approximated problems, $B = \mathbb{R}^N$).

Definition 3.1.

A regular branch of solutions is a family of solutions of (3.15), depending twice continuously differentiably of a parameter s ; we set :

$$(3.16) \quad \Gamma_{a,b} = \{(u(s), \lambda(s)), s_a \leq s \leq s_b\}.$$

Our purpose is to compute the regular branches of solutions of problem (3.15).

3.2.2. - Parametrization

The standard approach is almost invariably to use λ , one of the naturally occurring parameters of the problem, as the parameter defining solution arcs, $u(\lambda)$. Indeed, if for $\lambda = \lambda_0$, we get an isolated solution, u_0 (i.e.) if the linear operator :

$$(3.17) \quad G_u^0 = G_u(u_0, \lambda_0),$$

is an isomorphism of B onto itself and if the operator G is continuously differentiable in a neighbourhood of the solution (λ_0, u_0) , the implicit function theorem shows the existence of a regular arc of solutions : $u = u(\lambda)$, for λ belonging to a suitable neighbourhood of λ_0 .

Moreover, if G is regular, $\frac{du}{d\lambda}(\lambda)$ exists and satisfies :

$$(3.18) \quad G_u(u(\lambda), \lambda) \cdot \frac{du}{d\lambda}(\lambda) = -G_\lambda(u(\lambda), \lambda).$$

A large number of methods are available to compute the solution branches in a neighbourhood of (u_0, λ_0) : particularly, we may compute $\frac{du}{d\lambda}(\lambda_0)$, by Equation (3.18), and predict a solution by continuation for $\lambda = \lambda_0 + \delta\lambda$. This predictor will then be an initialization for one of the algorithms proposed in section 3.1.

This prediction can be simply done by an Euler step :

$$(3.19) \quad u^0(\lambda_0 + \delta\lambda) = u(\lambda_0) + \frac{du}{d\lambda}(\lambda_0) \cdot \delta\lambda.$$

Then, we shall use either a Newton method, (see Sec. 3.2) and then compute $u^{P+1}(\lambda_0 + \delta\lambda)$ from $u^P(\lambda_0 + \delta\lambda)$ by :

$$(3.20) \quad \begin{cases} G_u(u^P(\lambda_0 + \delta\lambda), \lambda_0 + \delta\lambda) \cdot \delta u^P = -G(u^P(\lambda_0 + \delta\lambda), \lambda_0 + \delta\lambda); \\ u^{P+1}(\lambda_0 + \delta\lambda) = u^P(\lambda_0 + \delta\lambda) + \delta u^P, \end{cases}$$

or, use a conjugate gradient method to minimize the functional :

$$(3.21) \quad \left\{ \begin{array}{l} J_{\lambda_0 + \delta\lambda}(u) = \frac{1}{2} (A(\xi), \xi), \text{ where :} \\ A\xi = G(u(\lambda_0 + \delta\lambda), \lambda_0 + \delta\lambda). \end{array} \right.$$

It is obvious that these methods allow us to compute the arcs composed of isolated solutions, but fail when we approach a point where G_u^0 is singular ; indeed :

- in the case of the Newton method, the operator G_u is not invertible any more and we may not be able to construct the sequence $\{u^n\}$. Besides, the sequence $\{u^n\}$ may not be convergent.
- in the case of the conjugate gradient method, we get the same phenomenon.

The basic idea to circumvent this, is due to H.B. Keller [16] and consists in using a normal parametrization :

$$\begin{aligned} u &= u(s), \\ \lambda &= \lambda(s), \end{aligned}$$

which is defined using an auxiliary equation added to the system to get the problem :

$$(3.22) \quad \left\{ \begin{array}{l} G(u(s), \lambda(s)) = 0, \\ N(u(s), \lambda(s), s) = 0, \end{array} \right.$$

where $N : B \times \mathbb{R}^2 \rightarrow \mathbb{R}$ defines the normal parameter s , on the arc of solutions.

Introduce then the new unknown $x \in \mathbb{X} = B \times \mathbb{R}$ and the operator $P : \mathbb{X} \times \mathbb{R} \rightarrow \mathbb{X}$ by :

$$(3.23) \quad x(s) = (u(s), \lambda(s)),$$

and :

$$(3.24) \quad P(x(s), s) = \begin{pmatrix} G(u(s), \lambda(s)) \\ N(u(s), \lambda(s), s) \end{pmatrix}.$$

The new problem is to find the solution, $x(s)$, of :

$$(3.25) \quad P(x(s), s) = 0.$$

Then, if for $s = s_0$: a solution of (3.25) is isolated, (i.e.) if the linear operator :

$$(3.26) \quad P_x(x(s_0), s_0) = \begin{pmatrix} G_u(x(s_0)) & G_\lambda(x(s_0)) \\ N_u(x(s_0), s_0) & N_\lambda(x(s_0), s_0) \end{pmatrix},$$

is non singular, and if the operator P is continuously differentiable in a neighbourhood of $(x(s_0), s_0)$, then the implicit function theorem insures the existence of a regular arc of solutions for s belonging to a convenient interval around s_0 . Moreover, on this regular arc, $\dot{x}(s)$ (derivative of x with respect to s) satisfies :

$$(3.27) \quad P_x(x(s), s) \cdot \dot{x}(s) = - P_s(x(s), s) = \begin{pmatrix} 0 \\ - N_s(x(s), s) \end{pmatrix}.$$

Now continuation in s could proceed in exact analogy with (3.19)-(3.21).

The main advantage of this formulation is that P_x can be non singular, even though G_u is singular, and that therefore we can track branches going through a turning point.

We recall the fundamental algebra lemma :

Lemma 3.1.

Let B be a Banach space, and \mathcal{A} the operator :

$$\mathcal{A} : B \times \mathbb{R}^n \rightarrow B \times \mathbb{R}^n,$$

of the form :

$$\mathcal{A} : \begin{pmatrix} A & B \\ C^* & D \end{pmatrix},$$

where :

$$\begin{aligned} A &: \mathbb{B} \rightarrow \mathbb{B} \\ B &: \mathbb{R}^n \rightarrow \mathbb{B} \\ C^* &: \mathbb{B} \rightarrow \mathbb{R}^n \\ D &: \mathbb{R}^n \rightarrow \mathbb{R}^n. \end{aligned}$$

a) If A is non singular then \mathcal{K} is non singular iff :

$$(\alpha) D - C^* A^{-1} B \text{ is non singular.}$$

b) If A is singular and :

$$(\beta) \dim N(A) = \text{codim } R(A) = n,$$

then \mathcal{K} is non singular iff :

$$(\gamma_1) \dim R(B) = n,$$

$$(\gamma_2) R(B) \cap R(A) = 0,$$

$$(\gamma_3) \dim R(C^*) = n,$$

$$(\gamma_4) N(A) \cap N(C^*) = 0.$$

c) If A is singular, and $\dim N(A) > n$, then \mathcal{K} is singular.

For the proof, see H.B. Keller [16].

Henceforth, we shall choose a parametrization as follows :

$$(3.28) \quad N(u(s), \lambda(s), s) = \theta \|\dot{u}\|^2 + (1-\theta) |\lambda|^2 - 1,$$

θ belonging to $]0, 1[$, where $\|\cdot\|$ is an appropriate norm on \mathbb{B} .

In practice, we shall use approximations of (3.28) as follows :

- if we know a solution $\{u(s_0), \lambda(s_0)\}$, of (3.15), in a neighbourhood of s_0 we shall use :

$$(3.29) \quad N_1(u(s), \lambda(s), s) = \theta \left\| u(s) - u(s_0) \right\|^2 + (1-\theta) \left| \lambda(s) - \lambda(s_0) \right|^2 - (s-s_0)^2 = 0.$$

- if, moreover, the tangent vector $\{\dot{u}_0, \dot{\lambda}_0\} = \{\dot{u}(s_0), \dot{\lambda}(s_0)\}$ is known and satisfies (3.28), we shall use

$$(3.30) \quad N_2(u(s), \lambda(s), s) = \theta (\dot{u}_0, u(s) - u(s_0)) + (1-\theta) \dot{\lambda}_0 \cdot (\lambda(s) - \lambda(s_0)) - (s-s_0) = 0,$$

where (\cdot, \cdot) is the scalar product associated to the norm $\|\cdot\|$.

3.2.3. - Continuation through regular and limit points

Let $\{u_0, \lambda_0\}$ be a solution of (3.15) and $\{\dot{u}_0, \dot{\lambda}_0\}$ satisfying :

$$(3.31)a \quad G_u^0 \cdot \dot{u}_0 + G_\lambda^0 \cdot \dot{\lambda}_0 = 0,$$

$$(3.31)b \quad \|\dot{u}_0\|^2 + |\dot{\lambda}_0|^2 > 0.$$

Definition 3.2.

The solution $\{u_0, \lambda_0\}$ is a regular point if $\{\dot{u}_0, \dot{\lambda}_0\}$ satisfies (3.31) and :

$$(3.32) \quad G_u^0 = G_u(u_0, \lambda_0)$$

is a non singular operator.

Definition 3.3

The solution $\{u_0, \lambda_0\}$ is a turning bending point if $\{\dot{u}_0, \dot{\lambda}_0\}$ satisfies (3.31) and :

$$(3.33)a \quad \dim N(G_u^0) = \text{codim } R(G_u^0) = 1,$$

$$(3.33)b \quad *G_\lambda^0 \notin R(G_u^0).$$

Remark 3.1

Let $\{u^*, \lambda^*\}$ be a turning point, we shall get :

$$G_u(u^*, \lambda^*)\dot{u} = -G_\lambda(u^*, \lambda^*)\dot{\lambda}^*,$$

which implies with (3.33) that : $\dot{\lambda}^* = 0$.

Moreover, the hypothesis (3.31)b implies $\dot{u}^* \neq 0$, and we get one of the two behaviors shown on the following figure :

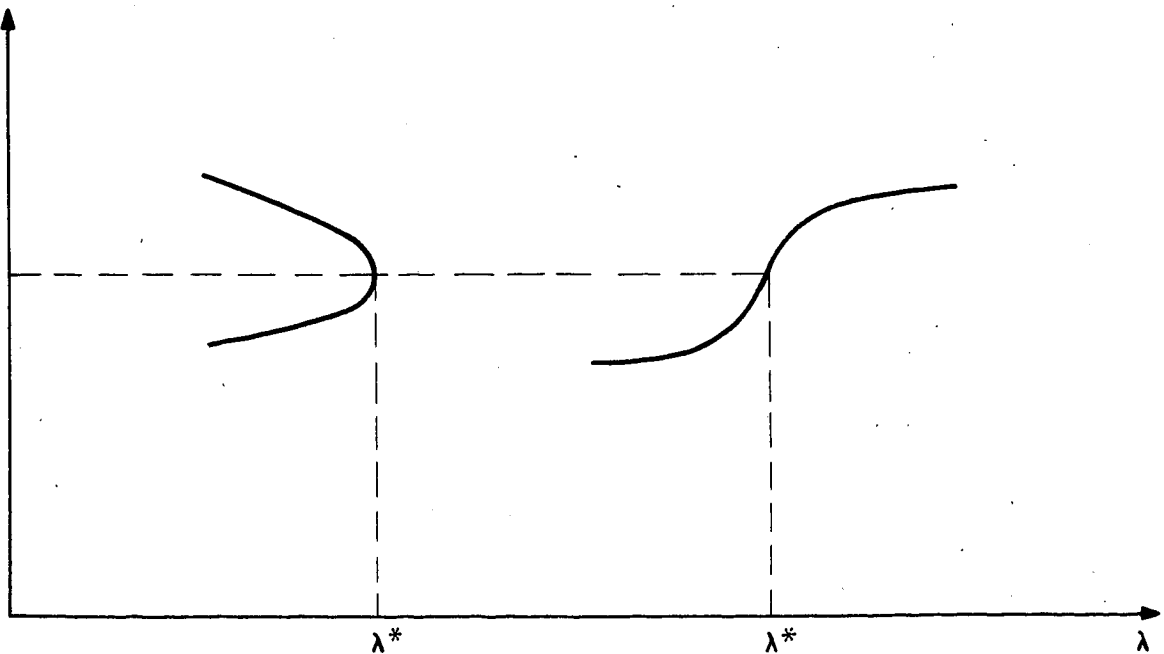

Theorem 3.1.

If $\{u_0, \lambda_0\}$ is a regular or a turning point, and if G is twice continuously differentiable in a neighborhood of $\{u_0, \lambda_0\}$, then, for s belonging to a suitable neighborhood of s_0 , there exists a unique regular arc of solutions $x = x(s) = \{u(s), \lambda(s)\}$ of (3.25).

On this arc, the linear operator $P_x(x(s), s)$ is non singular.

Proof

It is sufficient to prove that $P_x^0(x(s_0), s_0)$ is non singular, then we use the implicit function theorem.

From (3.26), (3.30), we have :

$$(3.34) \quad P_x^0 = \begin{pmatrix} G_u^0 & G_\lambda^0 \\ \theta \dot{u}_0^* & (1-\theta)\dot{\lambda}_0 \end{pmatrix}.$$

a) Let us first consider the case of a regular point

We have necessarily $\dot{\lambda}_0 \neq 0$; indeed, in the opposite case, the condition : $\dot{\lambda}_0 = 0$, with (3.31)a and (3.32) implies $\dot{u}_0 = 0$, in contradiction with the condition (3.31)b. We get then :

$$(i) \quad \frac{\dot{u}_0}{\dot{\lambda}_0} = -(G_u^0)^{-1} G_\lambda^0.$$

Use then lemma 3.1. : from part (a) of that lemma, we get : P_x^0 is regular iff :

$$(ii) \quad (1-\theta)\dot{\lambda}_0 + \theta(\dot{u}_0, (G_u^0)^{-1} G_\lambda^0) \neq 0,$$

which is equivalent, in this case to :

$$(iii) \quad (1-\theta)\dot{\lambda}_0 + \theta(\dot{u}_0, \frac{\dot{u}_0}{\dot{\lambda}_0}) \neq 0,$$

or :

$$(iv) (1-\theta)\dot{\lambda}_0^2 + \theta \|\dot{u}_0\|^2 \neq 0$$

which is satisfied since $\dot{\lambda}_0$ does not vanish.

b) Now consider the case of a turning point:

We shall apply part b of lemma 3.1 ; let us check assumptions γ_1 to γ_4 .

With the condition (3.33)a we have to check :

$$(\gamma_1) \dim R(G_\lambda^0) = 1,$$

$$(\gamma_2) R(G_u^0) \cap R(G_\lambda^0) = \{0\},$$

$$(\gamma_3) \dim R(\dot{u}_0^*) = 1,$$

$$(\gamma_4) N(G_u^0) \cap N(\dot{u}_0^*) = \{0\}.$$

Condition (3.33)b provides (γ_1) and (γ_2) ; since \dot{u}_0 does not vanish, (γ_3) is satisfied.

Now, if :

$$v \in N(G_u^0) \cap N(\dot{u}_0^*),$$

we get :

$$\begin{cases} G_u^0 \cdot v = 0, \\ (\dot{u}_0^*, v) = 0. \end{cases}$$

We have (remark 3.1) $\dot{\lambda}_0 = 0$ and $G_u^0 \cdot \dot{u}_0 = 0$, and since \dot{u}_0 does not vanish, necessarily \dot{u}_0 belongs to $N(G_u^0)$. Moreover, since $\dim N(G_u^0)$ is equal to 1 :

$$v \in N(G_u^0)$$

implies that v belongs to $\mathbb{R}\dot{u}_0$. Then :

$$(\dot{u}_0^*, v) = 0 \quad \text{implies} \quad \|\dot{u}_0\|^2 = 0 \quad \text{or} \quad v = 0$$

□

As a conclusion of this paragraph, we have shown that any solution arcs of problem (3.15), composed of regular or turning points, can be computed by a continuation method using the N_2 normalization. We can also justify the use of the N_1 normalization ; for regular arcs, we have :

$$\begin{aligned} u(s) - u(s_0) &= \dot{u}(s_0)(s-s_0) + \varepsilon(|s-s_0|^2), \\ \lambda(s) - \lambda(s_0) &= \dot{\lambda}(s_0)(s-s_0) + \varepsilon(|s-s_0|^2). \end{aligned}$$

For further details, see Reinhart [22], Guyot [9], Glowinski [8].

3.3. - Numerical solution of the Falkner Skan equation

We want to find the set of extremal solutions of the Falkner Skan equation, which amounts to find the branches of solutions $\{\alpha, \beta\}$, where $\{\alpha, \beta\}$ belongs to E , defined by :

$$E = \{ \{\alpha, \beta\}, \alpha, \beta \in \mathbb{R} \text{ such that there exists at least one solution of the initial value problem (3.35) with the extremality condition (3.36)} \},$$

where :

$$(3.35) \quad \begin{cases} y''' + yy'' + \beta(1-y'^2) = 0, \\ y(0) = y'(0) = 0, \\ y''(0) = \alpha, \end{cases}$$

and

$$(3.36) \quad \begin{cases} y \text{ minimizes the quantity } \Delta : \\ \Delta = |\dot{y}'(A) - 1|. \end{cases}$$

The methods proposed in paragraph 2, allowed us to find solutions of (3.35) and (3.36) for α or β , fixed ; the iterative method acts then on one of the two parameters α or β . We meet then some difficulties in the following two cases :

- a) the solution $\{\alpha, \beta\}$ corresponds to a turning point.
- b) for a fixed value of α (resp. β), there exist solutions for at least two narrow values of β (resp. α).

It appear then necessary to implement continuation methods to overcome these difficulties.

3.3.1. - A continuation - Newton method

Using a normal parametrization, we transform the previous problem onto the following :

Find $\{\alpha, \beta\}$ in \mathbb{R}^2 , satisfying :

$\alpha = \alpha(s)$, $\beta = \beta(s)$, for $s \in [s_0, s_1]$ and such that :

$$(3.37) \quad \begin{cases} y_2(A) - 1 = 0, \\ \dot{\alpha}(s)^2 + \dot{\beta}(s)^2 = 1, \end{cases}$$

where $\{y_1, y_2, y_3\}$ satisfies the canonical system :

$$(3.38) \quad Y' = \begin{pmatrix} y_1' \\ y_2' \\ y_3' \end{pmatrix} = \begin{pmatrix} y_2 \\ y_3 \\ -y_1 y_3 - \beta(1-y_2^2) \end{pmatrix} = F(Y), \text{ on }]0, \infty[,$$

$$Y(0) = \begin{pmatrix} y_1(0) \\ y_2(0) \\ y_3(0) \end{pmatrix} = \begin{pmatrix} 0 \\ 0 \\ \alpha \end{pmatrix}.$$

The numerical solution can be done by a Newton method. The ordinary differential system (3.38) will be integrated by a fourth order Runge Kutta method.

In order to compute the next point of a branch, we use two solutions on the curve : these two points will provide the path Δs , between two consecutive solutions on the branch, and an initialization point for the following solution.

Moreover, the knowledge of the two previous solutions gives as possible approximation of the arc length constraint :

$$f_2(\alpha(s), \beta(s)) = \frac{\alpha(s) - \alpha_2}{\Delta s_{MM_2}} \cdot \frac{\alpha_2 - \alpha_1}{\Delta s_{M_2M_1}} + \frac{\beta(s) - \beta_2}{\Delta s_{MM_2}} \cdot \frac{\beta_2 - \beta_1}{\Delta s_{M_2M_1}} - 1 = 0,$$

where $M_1 : \{\alpha_1, \beta_1\}$ and $M_2 : \{\alpha_2, \beta_2\}$ denotes the two previous solutions on the branch.

This approximation corresponds to the normalization (3.30) with $\theta = 1/2$, and a first order approximation of \dot{u}_0 and $\dot{\lambda}_0$. The Newton method applied to the solution of the problem :

$$F(\alpha, \beta) = \begin{pmatrix} f_1(\alpha, \beta) \\ f_2(\alpha, \beta) \end{pmatrix} = 0,$$

may be written as follows :

$$(3.40) \quad M^{(p+1)} = M^{(p)} - (F'(M^{(p)}))^{-1} \cdot F(M^{(p)}),$$

where $F'(M^{(p)})$ denotes the Jacobian matrix of F , at the point $M^{(p)} = (\alpha^{(p)}(s), \beta^{(p)}(s))$.

We have :

$$F' = \begin{pmatrix} \frac{\partial f_1}{\partial \alpha} & \frac{\partial f_1}{\partial \beta} \\ \frac{\partial f_2}{\partial \alpha} & \frac{\partial f_2}{\partial \beta} \end{pmatrix}.$$

The computation of $M^{(p+1)}$ entails the inversion of the jacobian matrix, F' ; in this case, this computation step is particularly simple : the 2×2 matrix is invertible by hand.

First, let us compute the matrix, $F'(M^{(p)})$; we have :

$$(3.41) \quad \frac{\partial f_1}{\partial \alpha} = \frac{\partial y_2(A)}{\partial \alpha},$$

$$(3.42) \quad \frac{\partial f_1}{\partial \beta} = \frac{\partial y_2(A)}{\partial \beta},$$

$$(3.43) \quad \frac{\partial f_2}{\partial \alpha} = \frac{1}{\Delta s_{MM_2}} \times \frac{\alpha_2 - \alpha_1}{\Delta s_{M_1M_2}},$$

$$(3.44) \quad \frac{\partial f_2}{\partial \beta} = \frac{1}{\Delta s_{MM_2}} \times \frac{\beta_2 - \beta_1}{\Delta s_{M_1M_2}}.$$

The evaluations of $\frac{\partial f_2}{\partial \alpha}$ and $\frac{\partial f_2}{\partial \beta}$ are obvious ; to compute the values of $\frac{\partial f_1}{\partial \alpha}$ and $\frac{\partial f_1}{\partial \beta}$, we differentiate system (3.38) with respect to α and β to get (see paragraph 2.2.2) :

$$\frac{\partial f_1}{\partial \alpha} = z_2(A)$$

where z_2 is the solution of the differential system :

$$(3.45) \quad z' = \begin{bmatrix} z_1 \\ z_2 \\ z_3 \end{bmatrix}' = \begin{bmatrix} 0 & 1 & 0 \\ 0 & 0 & 1 \\ -y_3 & 2\beta y_2 & -y_1 \end{bmatrix} \cdot \begin{bmatrix} z_1 \\ z_2 \\ z_3 \end{bmatrix},$$

with the initial data :

$$z(0) = \begin{pmatrix} 0 \\ 0 \\ 1 \end{pmatrix};$$

$\frac{\partial f_1}{\partial \beta} = w_2(A)$, where w_2 is the solution of the differential system :

$$(3.46) \quad w' = \begin{bmatrix} w_1 \\ w_2 \\ w_3 \end{bmatrix}' = \begin{bmatrix} 0 & 1 & 0 \\ 0 & 0 & 1 \\ -y_3 & 2\beta y_2 & -y_1 \end{bmatrix} \cdot \begin{bmatrix} w_1 \\ w_2 \\ w_3 \end{bmatrix} + y_2^2 - 1,$$

with the initial data :

$$w(0) = \begin{pmatrix} 0 \\ 0 \\ 0 \end{pmatrix}.$$

We then have to invert the 2×2 matrix, $F'(M^P)$ and set :

$$M^{(P+1)} = M^{(P)} - (F'(M^P))^{-1} F(M^P),$$

where the quantities $f_1, f_2, \frac{\partial f_i}{\partial \alpha}$ and $\frac{\partial f_i}{\partial \beta}$ are evaluated at the point $M^{(P)} = (\alpha^{(P)}, \beta^{(P)})$ for $i = 1, 2$.

The algorithm is stopped when both extremality criterion and the continuation constraint reach a value less than a given precision parameter. If the continuation constraint is difficult to satisfy, the arc length path Δs is automatically reduced.

3.3.2. - A least squares method

In the following, we present the least squares formulation of the previous problem (3.39). We have to minimize the quadratic functional :

$$J(\alpha(s), \beta(s)) = \frac{1}{2} (a_1 \tilde{\alpha}^2 + a_2 \tilde{\beta}^2),$$

where $\tilde{\alpha}, \tilde{\beta}$ are the state variables satisfying :

$$\begin{aligned} a_1 \tilde{\alpha} &= y_2(A) - 1, \\ a_2 \tilde{\beta} &= \dot{\alpha}(s)^2 + \dot{\beta}(s)^2 - 1, \end{aligned}$$

a_1, a_2 are scaling coefficients.

The gradient method for the minimization of J needs the computation of the derivative of J with respect to α and β .

$$\begin{cases} \frac{\partial J}{\partial \alpha} = a_1 \tilde{\alpha} \frac{\partial \tilde{\alpha}}{\partial \alpha} + a_2 \tilde{\beta} \frac{\partial \tilde{\beta}}{\partial \alpha}, \\ \frac{\partial J}{\partial \beta} = a_1 \tilde{\alpha} \frac{\partial \tilde{\alpha}}{\partial \beta} + a_2 \tilde{\beta} \frac{\partial \tilde{\beta}}{\partial \beta}. \end{cases}$$

Using the same approximation of the arclength constraint as in the previous method, the computation of the partial derivative of $\tilde{\alpha}$ and $\tilde{\beta}$ gives :

$$\left\{ \begin{array}{l} \frac{\partial \tilde{\alpha}}{\partial \alpha} = \frac{1}{a_1} z_2(A) \quad , \text{ see (3.43) ,} \\ \frac{\partial \tilde{\alpha}}{\partial \beta} = \frac{1}{a_1} w_2(A) \quad , \text{ see (3.44) ,} \\ \frac{\partial \tilde{\beta}}{\partial \alpha} = \frac{1}{a_2} \cdot \frac{1}{\Delta s_{MM_2}} \cdot \frac{\alpha_2 - \alpha_1}{\Delta s_{M_2M_1}} \quad , \\ \frac{\partial \tilde{\beta}}{\partial \beta} = \frac{1}{a_2} \cdot \frac{1}{\Delta s_{MM_2}} \cdot \frac{\beta_2 - \beta_1}{\Delta s_{M_2M_1}} \quad . \end{array} \right.$$

The gradient direction defined in (3.12), is then computed by :

$$(3.47) \quad \left\{ \begin{array}{l} g = (g_\alpha, g_\beta) , \\ a_1 g_\alpha = \frac{\partial J}{\partial \alpha} = \tilde{\alpha} z_2(A) + \tilde{\beta} \frac{\alpha_2 - \alpha_1}{\Delta s_{MM_2} \cdot \Delta s_{M_1M_2}} , \\ a_2 g_\beta = \frac{\partial J}{\partial \beta} = \tilde{\alpha} w_2(A) + \tilde{\beta} \frac{\beta_2 - \beta_1}{\Delta s_{MM_2} \cdot \Delta s_{M_1M_2}} . \end{array} \right.$$

We have now to apply the algorithm (3.7)-(3.10), with the new following notation :

$$u = \{\alpha, \beta\} ,$$

$$A = \begin{pmatrix} a_1 & 0 \\ 0 & a_2 \end{pmatrix}$$

$$g = \{g_\alpha, g_\beta\} \text{ and } z = \{z_\alpha, z_\beta\} .$$

The expensive steps of this computation will be :

- 1) the evaluation of the state variables $\tilde{\alpha}, \tilde{\beta}$, obtained by solving a system of the kind (3.38) to get $y_2(A)$
- 2) the computation of the gradient g ; we have to solve two differential systems of the kind (3.45) and (3.46) respectively to get $z_2(A)$ and $w_2(A)$.

This method is less efficient than the Newton method : in the case of a bidimensional problem, the inversion of the gradient matrix in the Newton method is done by hand ; conversely, for the conjugate gradient algorithm, the minimization step requires the evaluation of J at several values of the real parameter ρ , which requires in turn several solutions of the system via Runge Kutta.

4. - NUMERICAL EXPERIMENTS

4.1. - Solutions without overshoot

We have seen in Section 1.2.1 that the arc of solutions which does not present any overshoot points is composed of regular solutions in the plane (α, β) and of two singular points namely, the turning point (α^*, β^*) corresponding to the value $\alpha^* = 0$, and a singular limit point $\alpha = \beta = 0$. To compute the branch of solution going through the turning point, we have used the continuation-Newton method described in section 3.3.1.

As initializer points, we chose two solutions (α_1, β_1) and (α_2, β_2) given by H.B. Keller in [5] and corresponding to positive values of α and β . An approximate value of β^* has then been obtained :

$$\beta^* = - 0.19884;$$

and the computed branch going through this point reaches the value :

$$\alpha_c = - 0.062131,$$

$$\beta_c = - 0.018451.$$

Beyond this value, the computation was stopped by overflow ; this behavior is similar to the case where α and β are non positive and when there is no solutions.

The solution branch is shown on figure 4.1 ; on figure 4.2, we show the evolution of the speed profile f' when β goes to zero with negative values.

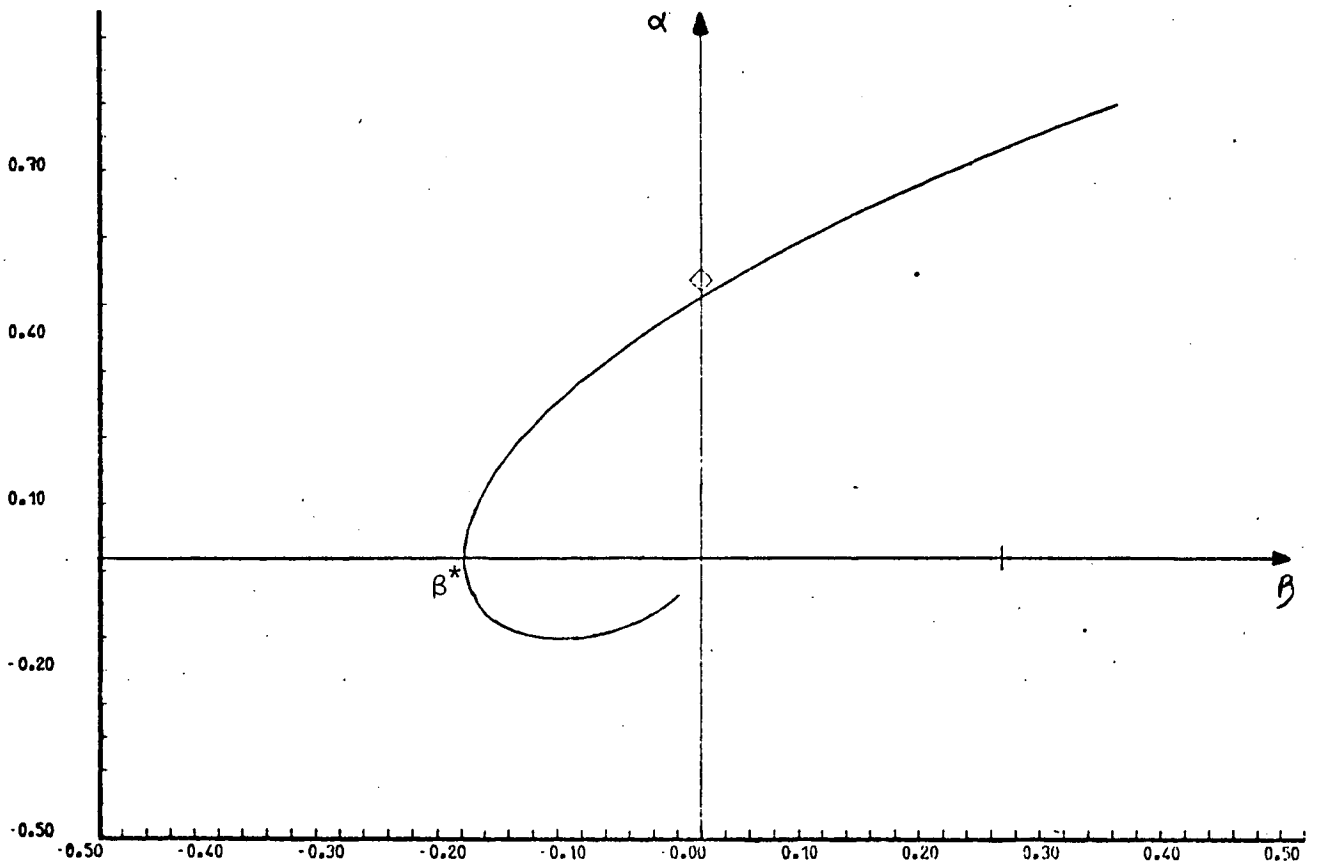

Figure 4.1. - Solutions without overshoot

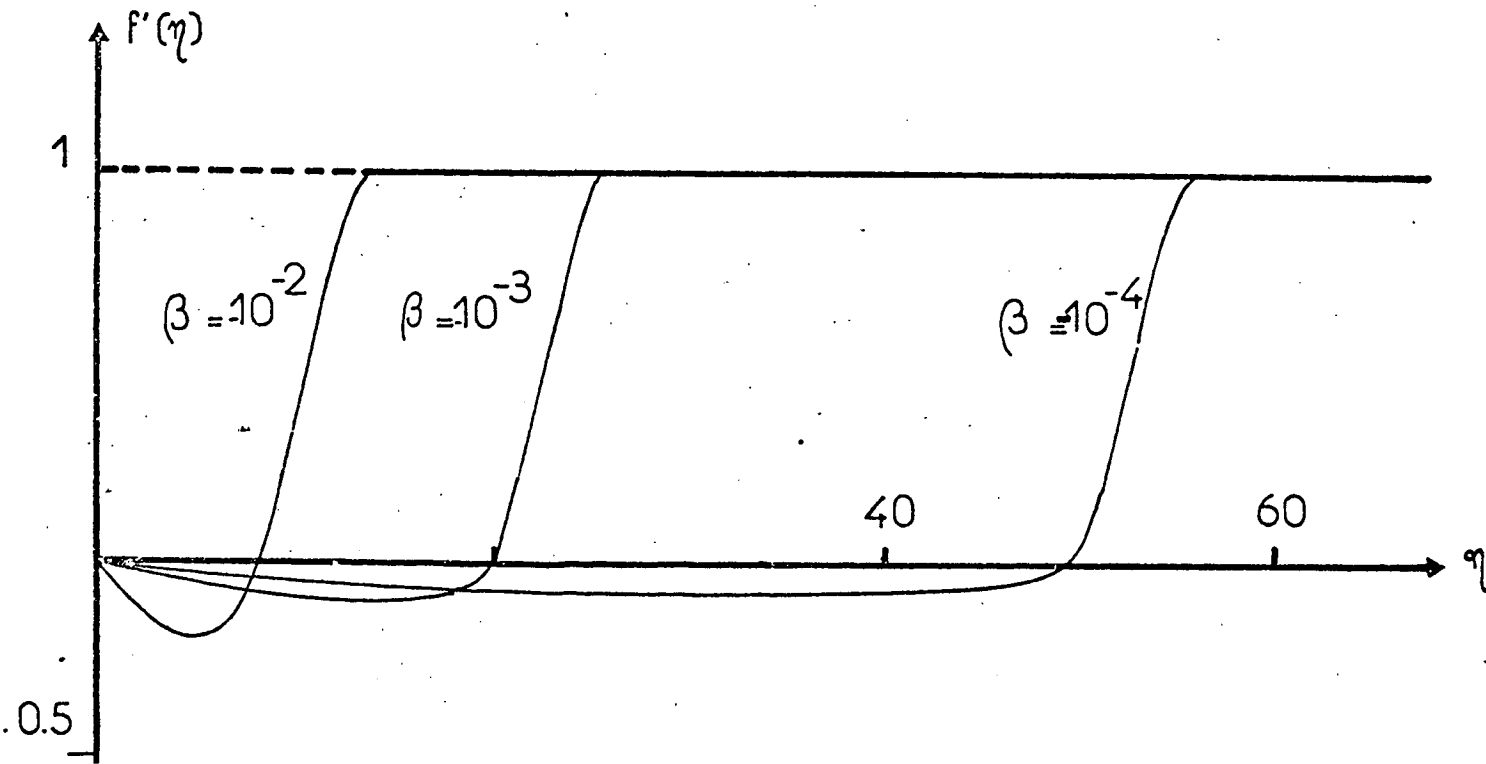

Figure 4.2. - Evolution of the speed profile when beta goes to zero

SEVEN BRANCHES OF EXTREMAL SOLUTIONS

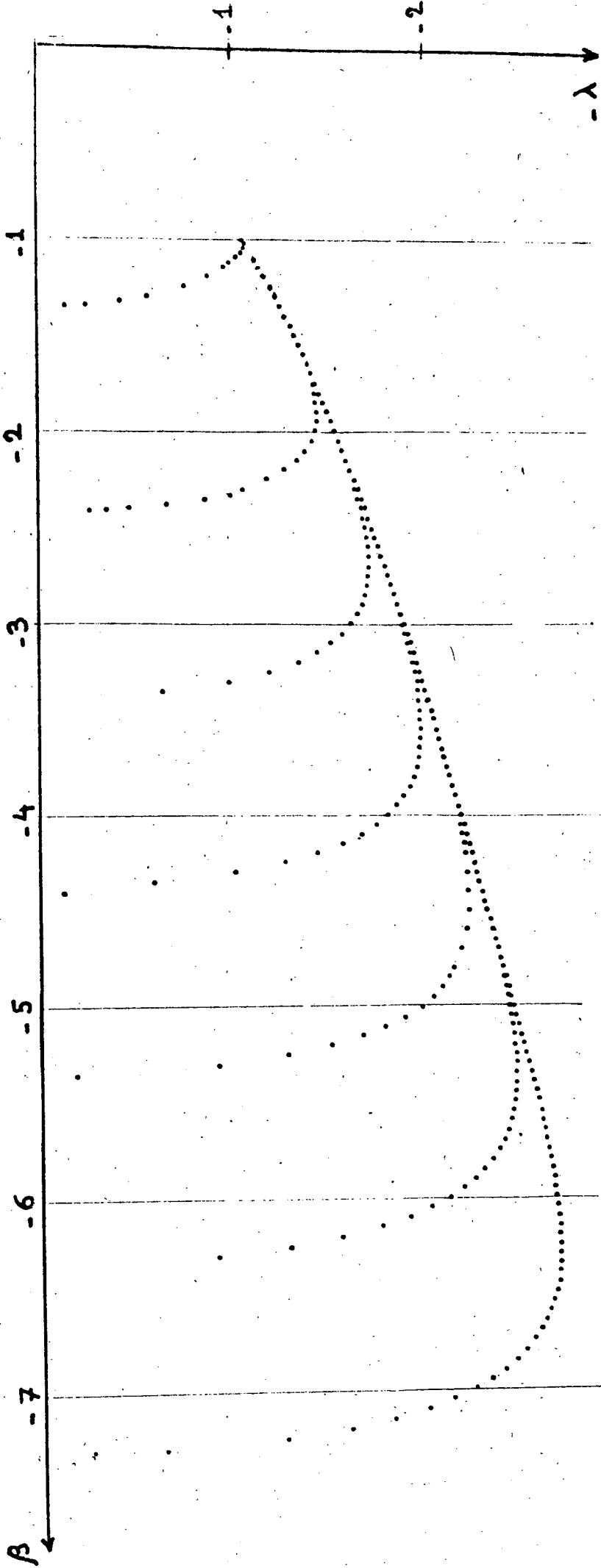

Figure 4.3

4.2. - Branches of extremal solutions with overshoot

Using both methods described in section 2 and 3, we have obtained some interesting results concerning the first seven branches of extremal solutions. The global results are shown in figure 4.3 in the (α, β) plane. Each branch can be characterized by the number of roots of the equation $f'-1 = 0$; this can be observed in figures 4.4 to 4.10, where the shape of the speed f' is represented for each branch. In addition, for a given branch of extremal solutions, we can study the behavior of f' when β goes to zero.

For example, in figure 4.11, we have represented the solution f' for seven values of (α, β) on the same branch. We can observe that the amplitude of the overshoot grows as β goes to zero, and the position of the overshoot progresses to the right. It follows that the convergence of f' to the value $f' = 1$, may appear for a larger value of the abscissa ; this implies numerical difficulties concerning the choice of the large scale A .

Concerning the asymptotic behavior of the branches, we can see in figure 4.3 that the different branches join along a "limit branch" when β goes to zero with negative values.

It is then of most interest to look, for a fixed value of β , at the different solutions on each branch.

We can see on figure 4.12 that even for two nearly values of α , we have obtained (see (2) and (3)) two solutions quite different. This results seems to confirm the asymptotic convergence of the branches when β goes to zero.

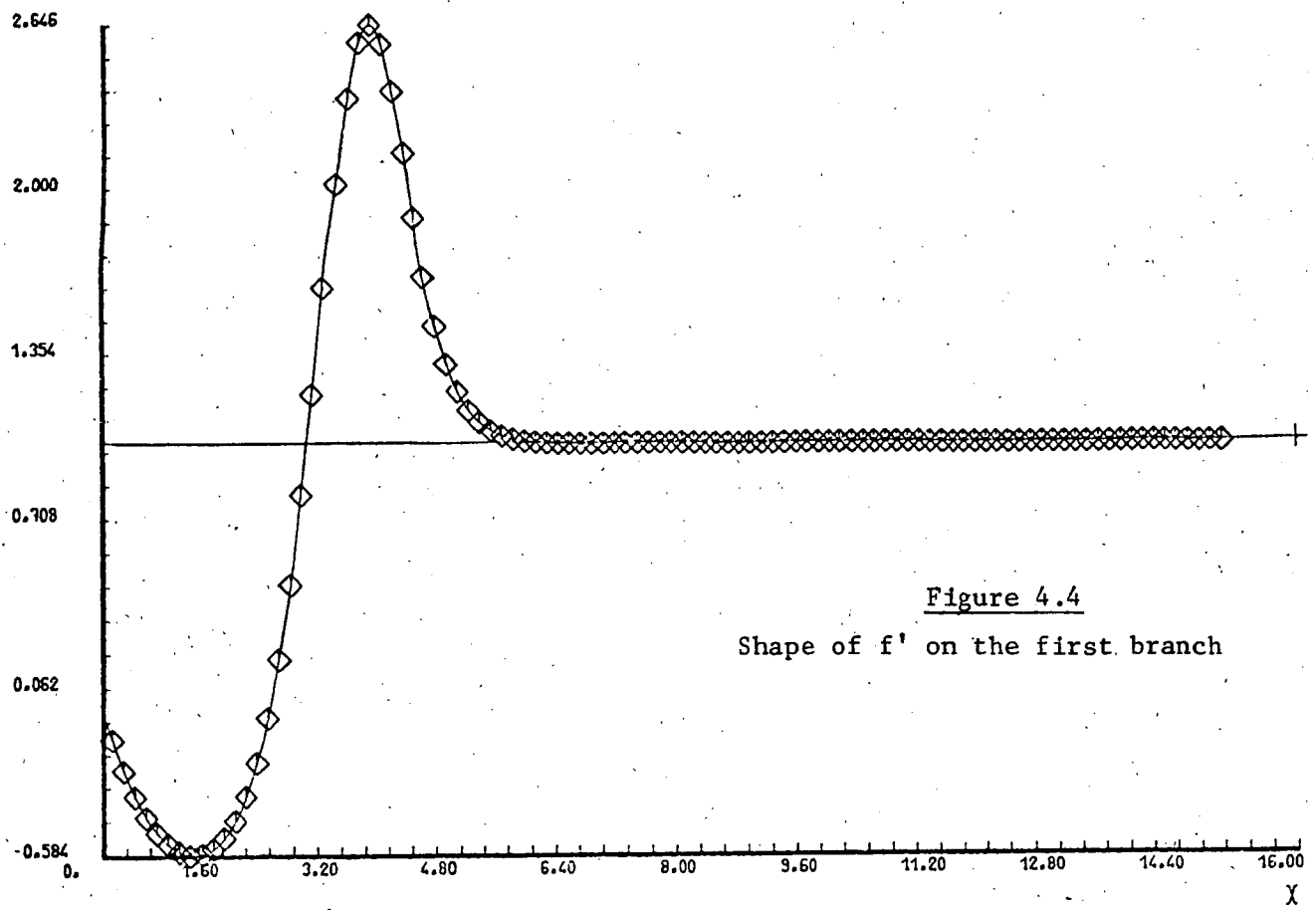

FALKNER-SKAN BETA = -0.1100000E 01 ALPHA = -0.1046670E 01

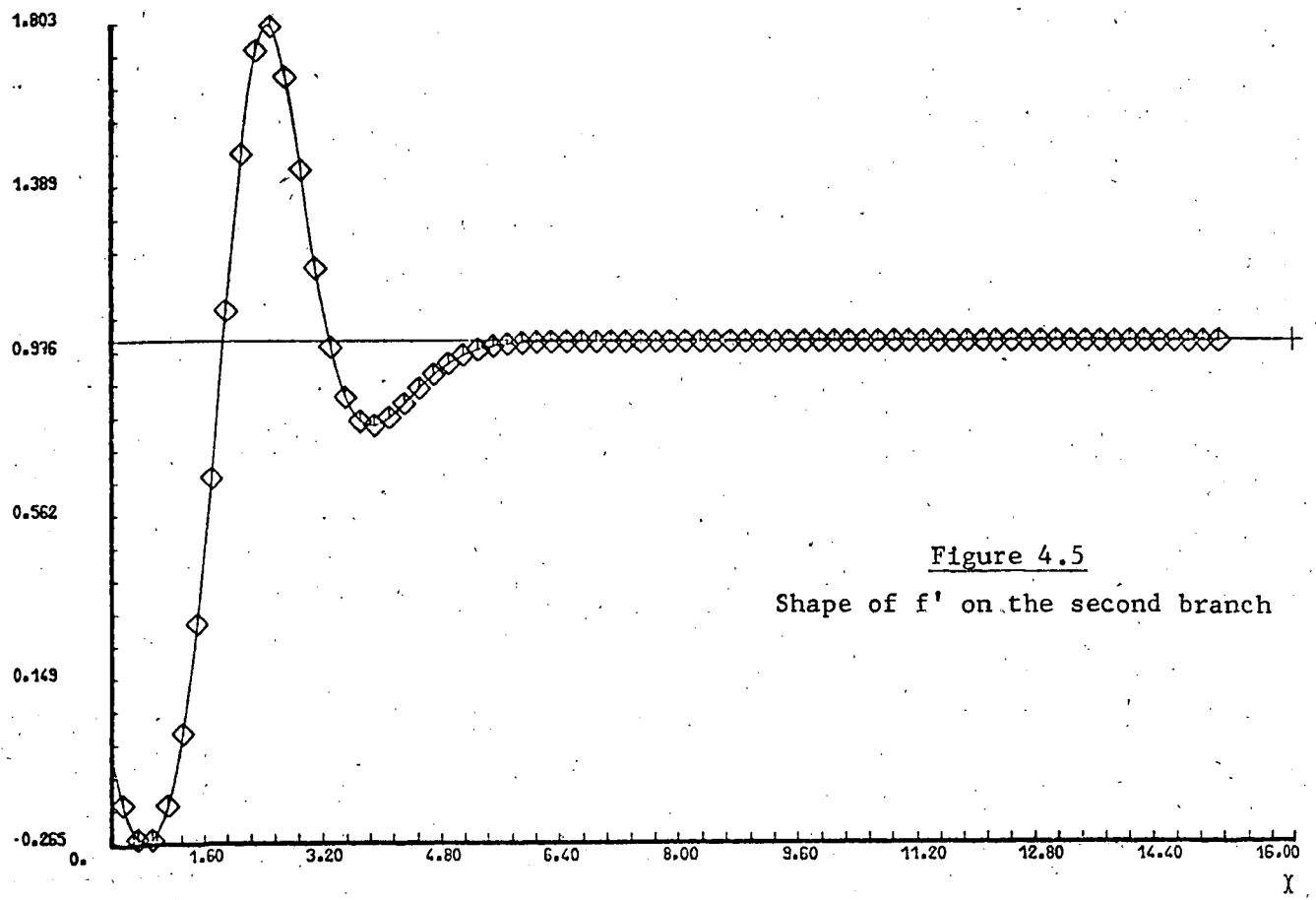

FALKNER-SKAN BETA = -0.2300000E 01 ALPHA = -0.1088959E 01

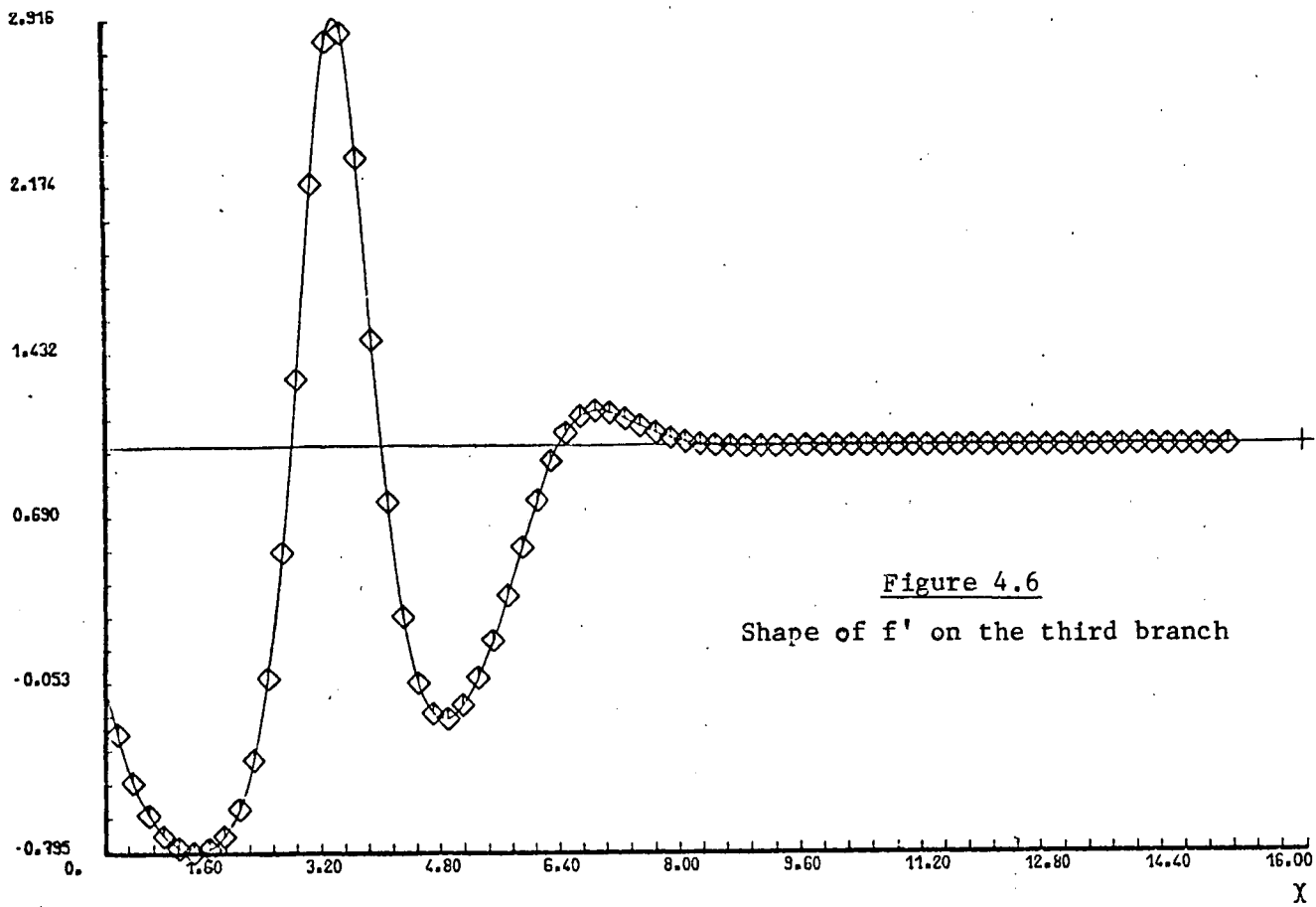

FALKNER-SKAN BETA -0.2300000E 01 ALPHA= -0.1668403E 0

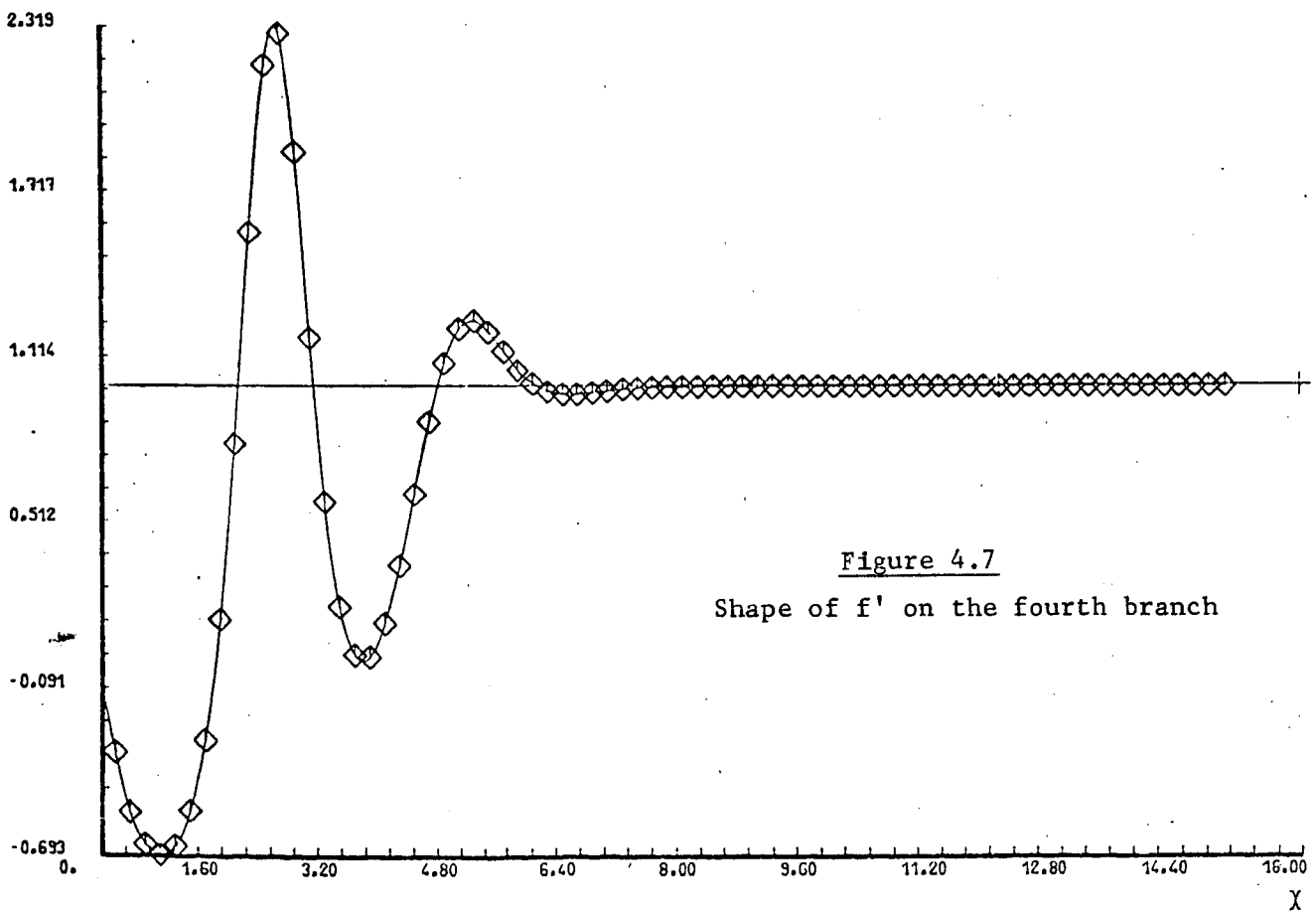

FALKNER-SKAN BETA -0.3550000E 01 ALPHA= -0.2015560E 0

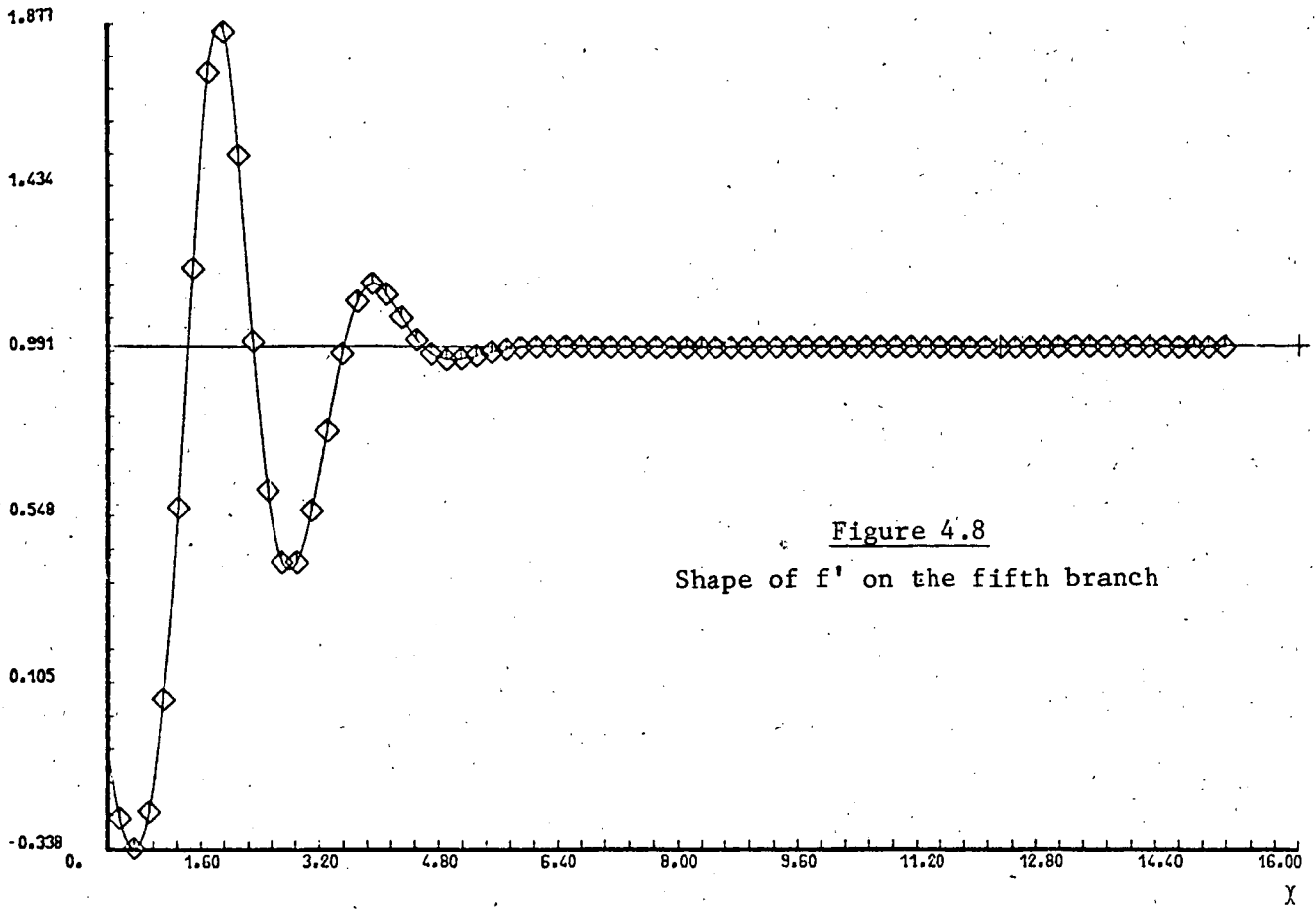

FALKNER-SKAN BETA -0.5099999E 01ALPHA= -0.1817520E 0

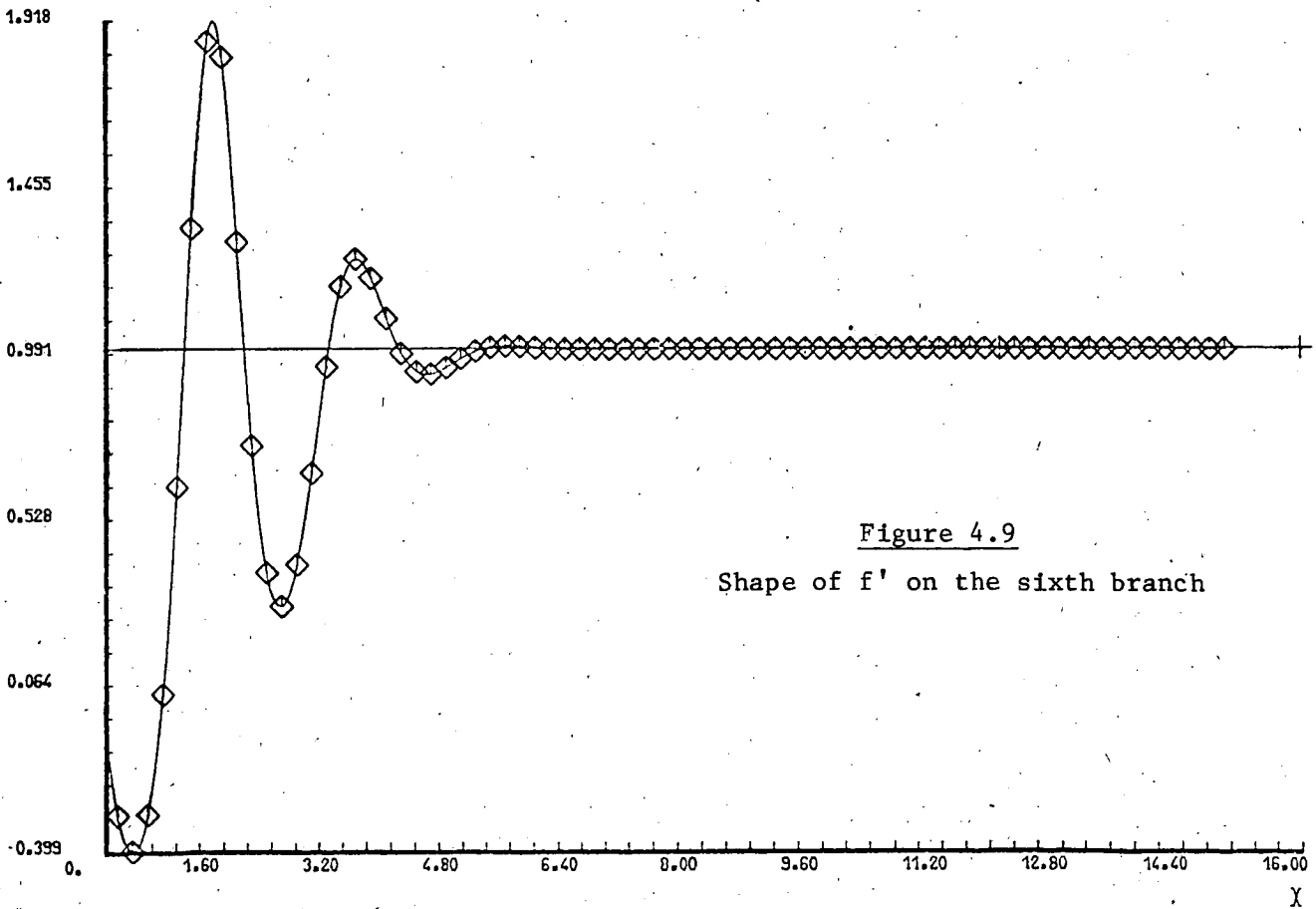

FALKNER-SKAN BETA -0.6000000E 01ALPHA= -0.2126810E 0

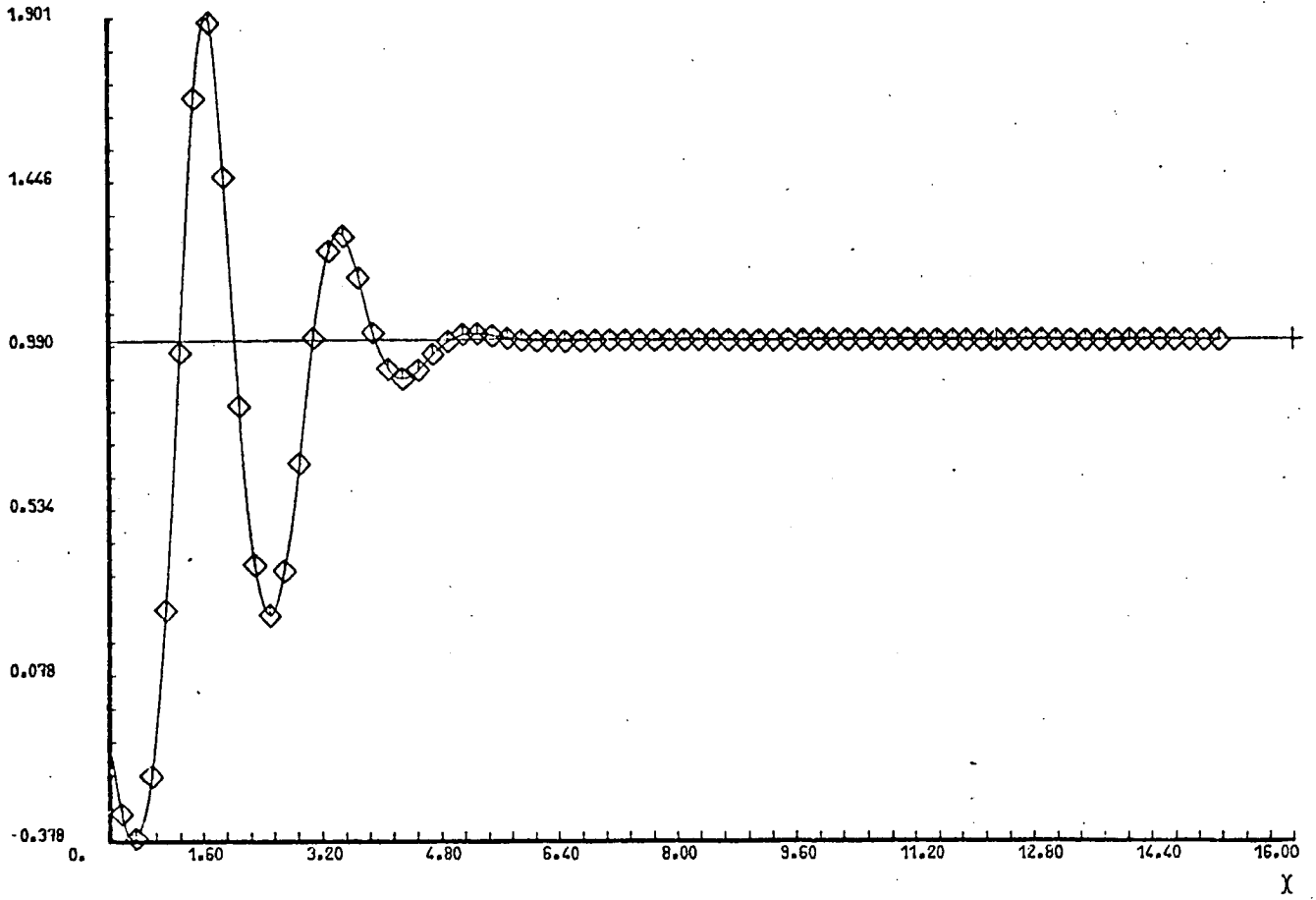

FALKNER-SKAN BETA -0.7000000E 01 ALPHA= -0.2241680E 0

Figure 4.10 : Shape of f' on the seventh branch

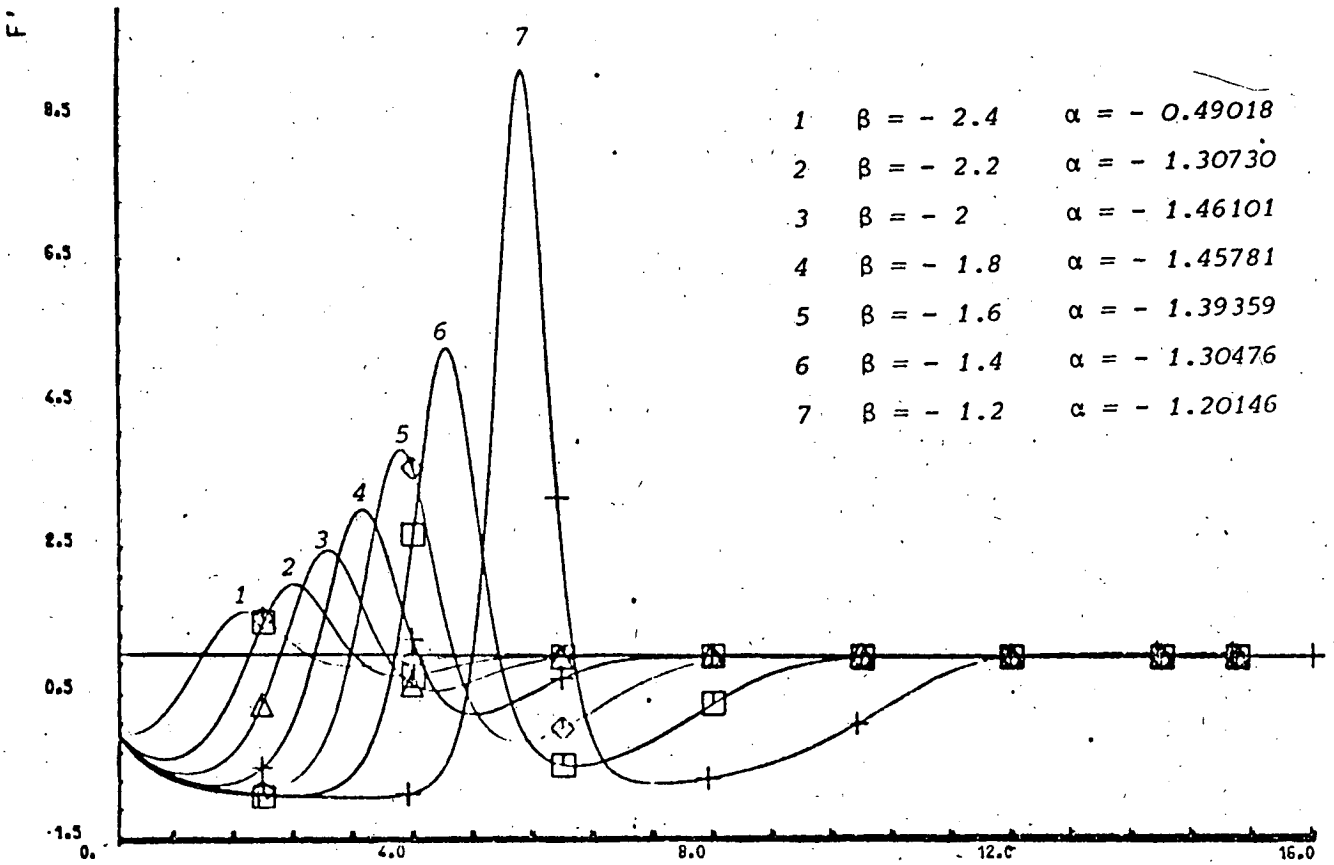

FALKNER- SKAN

Figure 4.11 : Evolution of overshoots on the second branch

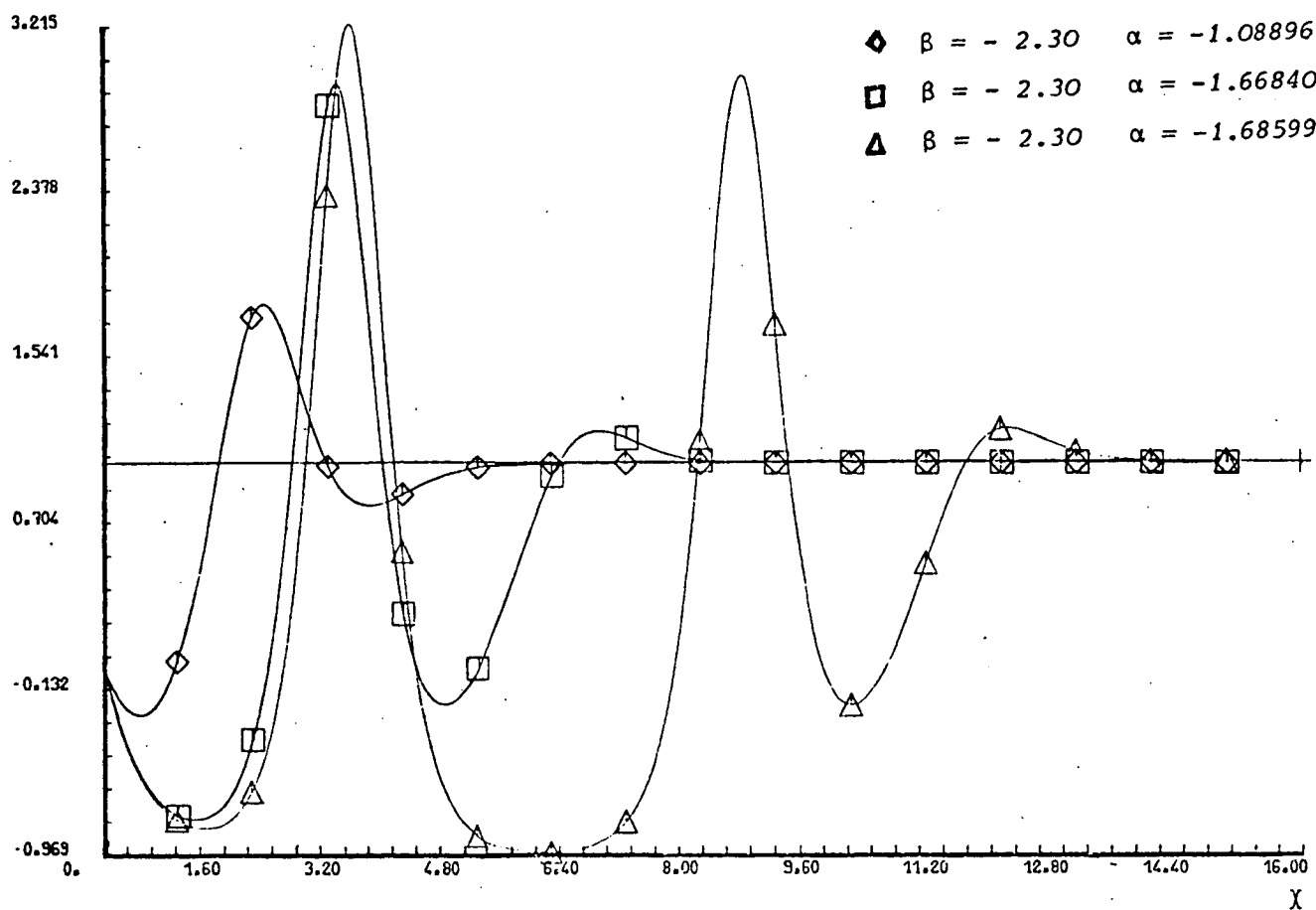

FALKNER-SKAN BETA -0.2300000E 01

Figure 4.12 : Three solutions for $\beta = -2.30$

ACKNOWLEDGMENTS

The authors would like to thank Professor Ridgway Scott for his careful reading of the paper and the various improvements he has suggested.

REFERENCES

- [1] BANKS W.H., DRAZIN P.G., Perturbation methods in boundary layer theory, J.F.M., vol. 58, n° 4, pp. 763-776, 1973.
- [2] BRAUNER C.M., LAINE C., NICOLAENKO B., Further solutions of the Falkner Skan equation for $\beta = -1$ and $\gamma = 0$. Mathematika, to appear.
- [3] BROWN S.N., A differential equation occuring in boundary layer theory, Mathematika, 13, pp. 140-146, 1966.
- [4] BROWN S.N., STEWARTSON K., On the reversed flow solutions of the Falkner Skan equation, Mathematika, 13, pp. , 1966.
- [5] CEBECCI T., KELLER H.B., Shooting and parallel shooting methods for solving the Falkner Skan boundary layer equation, J. Comp. Phys., 7, pp. 289-300, 1971.
- [6] CRAVEN A.H., PELETIER L.A., On the uniqueness of solutions of the Falkner Skan equation, Mathematika, 19, pp. 129-133, 1972.
- [7] FALKNER V.M., SKAN Miss S.W., Phil. Mag., 12, p. 865, Aero. Res. Comm. R. and M., 1314, 1931.
- [8] GLOWINSKI R., KELLER H.B., REINHART L., Continuation-conjugate gradient methods for the least square solution of non linear boundary value problems, SIAM, to appear.
- [9] GUYOT J., Etude mathématique et numérique d'un problème elliptique non linéaire avec points de retournement, Thèse, Lyon, 1981.
- [10] HARTMAN P., On the asymptotic behavior of solutions of a differential equation in boundary layer theory, Zeitschrift für angewandte mathematik and mechanik, 44, pp. 123-128, 1964.

- [11] HARTMAN P., Ordinary differential equations, John Wiley, New York, 1964.
- [12] HARTREE D.R., On an equation occurring in Falkner and Skan's approximate treatment of the equations of the boundary layer, Proc. Camb. Phil. Sec, 33, pp. 229-239, 1937.
- [13] HASTINGS S.P., Reversed flow solutions of the Falkner Skan equation, SIAM, vol. 22, n° 2, mars 1972.
- [14] HASTINGS S.P., An existence theorem for a class of non linear boundary value problems including that of Falkner Skan, Journal of differential equations, 9, pp. 580-590, 1971.
- [15] IGLISH R., KEMNITZ F., Über die in der Grenzschichttheorie auf tretende differential gleichung, $f''' + ff'' + \beta(1-f'^2) = 0$, für $\beta < 0$, bei gewissen absauge und ausblasegesetzen. 50 Jahre Grenzschicht forschung, H. GORTLER und W. TOLLMIE, Eds. Vieweg, Braunschweig, 1955.
- [16] KELLER H.B., Numerical solution of bifurcation and non linear eigenvalue problems. Application of bifurcation theory, Ed. Rabinowitz, Academic Press, 1977.
- [17] LIBBY P.A., LIU T.M., Further solutions of the Falkner Skan equation, AIAA J., 5, pp. 1040-1042, 1967.
- [18] LIONS J.L., Contrôle optimal des systèmes gouvernés par des équations aux dérivées partielles. Dunod, Paris, 1968.
- [19] PERIAUX J., Résolution de quelques problèmes non linéaires en aérodynamique par des méthodes d'éléments finis et moindres carrés fonctionnels, Thèse, Université Paris VI, 1979.
- [20] POLAK E., Computational methods in optimization, Academic Press, New York, 1971.

- [21] POWELL M.J., Restart procedure for the conjugate gradient method, Math. programming, 12, 1977.
- [22] REINHART L., Sur la résolution numérique des problèmes aux limites non linéaires par des méthodes de continuation, Thèse 3ème cycle, Paris VI, 1980.
- [23] ROBERTS S.M. and SHIPMAN J.S., Two point boundary value problems : shooting methods. American Elsevier, 1972.
- [24] STEWARTSON K., Further solutions of the Falkner Skan equations, Proc. Camb. Phil. Soc., 50, pp. 454-465, 1954.
- [25] STEWARTSON K., Falkner Skan equations for wakes, AIAA J., vol. 2, n° 7, pp. 1327-1328, 1964.
- [26] SCHLICHTING H., Boundary layer theory, 6th Ed. Mac Graw Hill, 1968.
- [27] TROY W.C., Non monotonic solutions of the Falkner Skan boundary layer equation, Quat. App. Math., pp. 157-167, 1979.
- [28] WEYL H., On the differential equations of the simplest boundary layer problems, Annals of Mathematics, Vol. 43, N° 2, April 42, p. 381-407.
- [29] BRAUNER C.M., LAINE Cl., Etude de phénomènes de bifurcation (points de retournement) en théorie de la couche limite bidimensionnelle laminaire, Contrat DRET 79/214.

