



HAL
open science

Two parallel queues created by arrivals with two demands:the M/G/2 symmetrical case

François Baccelli

► **To cite this version:**

François Baccelli. Two parallel queues created by arrivals with two demands:the M/G/2 symmetrical case. RR-0426, INRIA. 1985. inria-00076130

HAL Id: inria-00076130

<https://inria.hal.science/inria-00076130>

Submitted on 24 May 2006

HAL is a multi-disciplinary open access archive for the deposit and dissemination of scientific research documents, whether they are published or not. The documents may come from teaching and research institutions in France or abroad, or from public or private research centers.

L'archive ouverte pluridisciplinaire **HAL**, est destinée au dépôt et à la diffusion de documents scientifiques de niveau recherche, publiés ou non, émanant des établissements d'enseignement et de recherche français ou étrangers, des laboratoires publics ou privés.

IRIA

CENTRE DE ROCQUENCOURT

Rapports de Recherche

N° 426

**TWO PARALLEL QUEUES
CREATED BY ARRIVALS
WITH TWO DEMANDS :
THE M/G/2 SYMMETRICAL CASE**

François BACCELLI

Juillet 1985

Institut National
de Recherche
en Informatique
et en Automatique

Domaine de Voluceau
Rocquencourt
B.P. 105

78153 Le Chesnay Cedex
France

Tel: 3 954 90 20

RESUME

On considère un réseau de deux files d'attente en parallèle où les clients accroissent simultanément les charges des deux files. Dans le cas où les arrivées forment un processus de Poisson et où les charges ont une distribution générale symétrique, on réduit le calcul des distributions stationnaire et transitoire à la solution de problèmes aux limites.

TWO PARALLEL QUEUES CREATED

BY ARRIVALS WITH TWO DEMANDS:

THE M/G/2 SYMMETRICAL CASE.

Frangois E. BACCELLI*

ABSTRACT

Networks of two parallel queues where arriving customers bring work to both queues are considered. In the case where the arrival process is Poisson and the amount of work brought by arriving customers has a general symmetrical joint distribution, complex variables functions techniques are used to obtain both the transient and the stationary behavior as the solution of basic boundary value problems.

* INRIA, FRANCE. This work was done while the author was visiting the applied probability group, Bell Communications Research.

INTRODUCTION

We consider a queuing system composed of two single server queues. Customers arrive to this system in a single stream. Each arrival creates simultaneously two work demands to be processed by the two servers. Such queuing models arise in many application areas including flexible manufacturing and parallel processing (e.g. the cobegin and coend structures in concurrent languages). The analytical characterization of the distribution of the number of customers at steady state has been derived by L. Flatto and S. Hahn [1] in the M/M/2 case (Poisson arrivals and independent exponentially distributed service demands). The present paper is concerned by the M/G/2 case (Poisson arrivals and possibly dependent, generally distributed service demands). In the particular case of exchangeable service demands, it is shown that both the transient and the stationary workload Laplace transforms can be obtained as the solution of basic boundary value problems. The main steps of this reduction are suggested by the recent work of J. W. Cohen and O. J. Boxma [2] and are organized in four sections : the first one is dedicated to the derivation of the basic functional equations satisfied by the workload Laplace transform and to the analysis of the so called kernel of the functional equation ; the second section is concerned by the determination of a suitable conformal mapping from a domain obtained when analyzing the kernel, onto the unit circle ; in the third section, it is shown how this conformal mapping can be used to reduce the solution of the functional equation to the solution of a basic boundary value problem on the unit circle ; the last section is devoted to the analytic continuation of the Laplace transform from the original domain where it is first determined onto the whole right half plane.

I. KERNEL ANALYSIS

I.1 NOTATIONAL AND ASSUMPTIONS

We shall denote as λ the intensity of the arrival Poisson process and as $(X_1^k, X_2^k)_{k \geq 0}$, the work demands created by the k -th arrival in queue one and two respectively. The successive work demands (X_1^k, X_2^k) will be assumed to be i.i.d. and independent of the arrival process. We shall denote the Laplace Stieltjes transform of (X_1^k, X_2^k) as

$$\Phi(s_1, s_2) = E[\exp(-s_1 X_1^k - s_2 X_2^k)], \operatorname{Re}(s_1) \geq 0, \operatorname{Re}(s_2) \geq 0.$$

The present study will be limited to the case where the random variables X_1^k and X_2^k are exchangeable. Equivalently, it will be assumed that for any complex numbers, s_1 and s_2 with positive real parts,

$$(1.1) \quad \Phi(s_1, s_2) = \Phi(s_2, s_1).$$

The analysis will require the following technical assumption : It will be assumed that for any $g \in R^+$ and $t \in R$, the function $\Phi(g+it, g-it)$ converges to zero when $|t| \rightarrow \infty$:

$$(1.2) \quad \lim_{|t| \rightarrow \infty} \Phi(g+it, g-it) = 0.$$

This assumption will be discussed and slightly weakened later on (section I. 3).

I.2 THE FUNCTIONAL EQUATIONS

Let $V_1(t)$ and $V_2(t)$ denote the workloads at time $t \geq 0$ in queue one and two respectively.

For $s_1, s_2 / \operatorname{Re}(s_1) \geq 0, \operatorname{Re}(s_2) \geq 0$, let

$$(1.3) \quad \Psi(t, s_1, s_2) = E[\exp \{-s_1 V_1(t) - s_2 V_2(t)\}] .$$

The evolution equation for $\Psi(t, s_1, s_2)$, based on the Markov property of $(V_1(t), V_2(t))$, $t \geq 0$, reads:

$$(1.4) \quad \frac{d}{dt} \Psi(t, s_1, s_2) =$$

$$[s_1 + s_2 - \lambda(1 - \Phi(s_1, s_2))] E[\exp\{-s_1 V_1(t) - s_2 V_2(t)\} \mathbf{1}(V_1(t) > 0, V_2(t) > 0)]$$

$$+ [s_1 - \lambda(1 - \Phi(s_1, s_2))] E[\exp\{-s_1 V_1(t)\} \mathbf{1}(V_1(t) > 0, V_2(t) = 0)]$$

$$+ [s_2 - \lambda(1 - \Phi(s_1, s_2))] E[\exp\{-s_2 V_2(t)\} \mathbf{1}(V_1(t) = 0, V_2(t) > 0)]$$

$$- \lambda(1 - \Phi(s_1, s_2)) P[V_1(t) = 0, V_2(t) = 0],$$

or equivalently:

$$(1.5) \quad \frac{d}{dt} \Psi(t, s_1, s_2) = [s_1 + s_2 - \lambda(1 - \Phi(s_1, s_2))] \Psi(t, s_1, s_2)$$

$$- s_2 E[\exp\{-s_1 V_1(t)\} \mathbf{1}(V_1(t) > 0, V_2(t) = 0)]$$

$$- s_1 E[\exp\{-s_2 V_2(t)\} \mathbf{1}(V_1(t) = 0, V_2(t) > 0)]$$

$$- (s_1 + s_2) P[V_1(t) = 0, V_2(t) = 0].$$

Adopting the notations

$$(1.6) \quad \begin{cases} \Psi_1(t, s_1) = E[\exp\{-s_1 V_1(t)\} \mathbf{1}(V_2(t) = 0)] \\ \Psi_2(t, s_2) = E[\exp\{-s_2 V_2(t)\} \mathbf{1}(V_1(t) = 0)] \end{cases}$$

and for $s > 0$,

$$(1.7) \quad \begin{cases} \Psi_s(s_1, s_2) = \int_0^\infty e^{-st} \Psi(t, s_1, s_2) dt \\ \Psi_{i,s}(s_i) = \int_0^\infty e^{-st} \Psi_i(t, s_i) dt, \quad i = 1, 2. \end{cases}$$

one gets the following functional equations for the transient case :

$$(1.8) \quad [s_1 + s_2 - \lambda(1 - \Phi(s_1, s_2)) - s] \Psi_s(s_1, s_2) = s_2 \Psi_{1,s}(s_1) + s_1 \Psi_{2,s}(s_2) - \Psi(0, s_1, s_2).$$

In the steady state analysis , the functional equation simply reads:

$$(1.9) \quad [s_1 + s_2 - \lambda(1 - \Phi(s_1, s_2))] \Psi(s_1, s_2) = s_2 \Psi_1(s_1) + s_1 \Psi_2(s_2),$$

when denoting as $\Psi(s_1, s_2)$ (resp. $\Psi_i(s_i)$) the function $\Psi(t, s_1, s_2)$ (resp. $\Psi_i(t, s_i)$) which, by assumption, does not depend upon t .

1.3 ANALYSIS OF THE KERNEL

1.3.1 THE TRANSIENT CASE

The aim of the present section is to determine a convenient zero of the kernel of the functional equation:

$$(1.10) \quad \Theta_s(s_1, s_2) = s_1 + s_2 - \lambda(1 - \Phi(s_1, s_2)) - s.$$

Let us first show that one can find such a zero when s_1 and s_2 have the following form:

$$(1.11) \quad \begin{cases} s_1 = g + it & , \operatorname{Re}(g) \geq 0, \\ s_2 = g - it & , t \in \mathbb{R}. \end{cases}$$

The equation $\Theta_s(g + it, g - it) = 0$ reads

$$(1.12) \quad g - \frac{s}{2} = \frac{\lambda}{2}(1 - \Phi(g + it, g - it)).$$

Notice first that

$$\Phi(g + it, g - it) = E[e^{-\sigma(X_1^t + X_2^t)} e^{-it(X_1^t - X_2^t)}].$$

Accordingly, the exchangeability assumptions (1.2) entails :

$$(1.13) \quad \begin{aligned} \Phi(g + it, g - it) &= \frac{1}{2}[\Phi(g + it, g - it) + \Phi(g - it, g + it)] \\ &= E[e^{-\sigma(X_1^t + X_2^t)} \cos(t(X_1^t - X_2^t))]. \end{aligned}$$

Equation (1.13) shows that $\theta_s(g + it, g - it)$ is a real valued function if g is real. We shall rely on this properly to prove that equation (1.12) has exactly one solution in the domain $\text{Re}(g) \geq 0$ and that this solution is real.

Lemma 1

Let s be a fixed real and positive number and t be a fixed real number. The equation $\theta_s(g + it, g - it) = 0$ of unknown g has one zero in the region $\text{Re}(g) \geq 0$. The multiplicity of this zero is one. \square

Proof

For g located on the imaginary axis

$$(1.14) \quad \left| g - \frac{s}{2} - \frac{\lambda}{2} \right| > \frac{\lambda}{2} \geq \left| \frac{\lambda}{2} \Phi(g + it, g - it) \right|.$$

This bound holds also for $|g| = R$ and $\text{Re}(g) \geq 0$, provided is R sufficiently large. Let now D_R be the region $|g| \leq R, \text{Re}(g) \geq 0$. Owing to (1.14), which holds on the boundary of D_R , Rouché's theorem entails that the function $\theta_s(g + it, g - it)$ has the same number of zeros in the domain D_R as the function $g - \frac{s}{2} - \frac{\lambda}{2}$, and this for any large R . \square

Lemma 2

Let s be a fixed real positive number and t be a fixed real number. The equation of unknown g :

$\Theta_s(g + it, g - it) = 0$ has at least one real and strictly positive solution. \square

Proof

For g real, the function

$$g \rightarrow \frac{\lambda}{2} (1 - \Phi(g + it, g - it))$$

is real valued and continuous. It's range is the real interval $[0, \lambda]$. Hence the graphs of this

function and the linear function $g \rightarrow g - \frac{\delta}{2}$ meet at least once as indicated in figure 1. \square

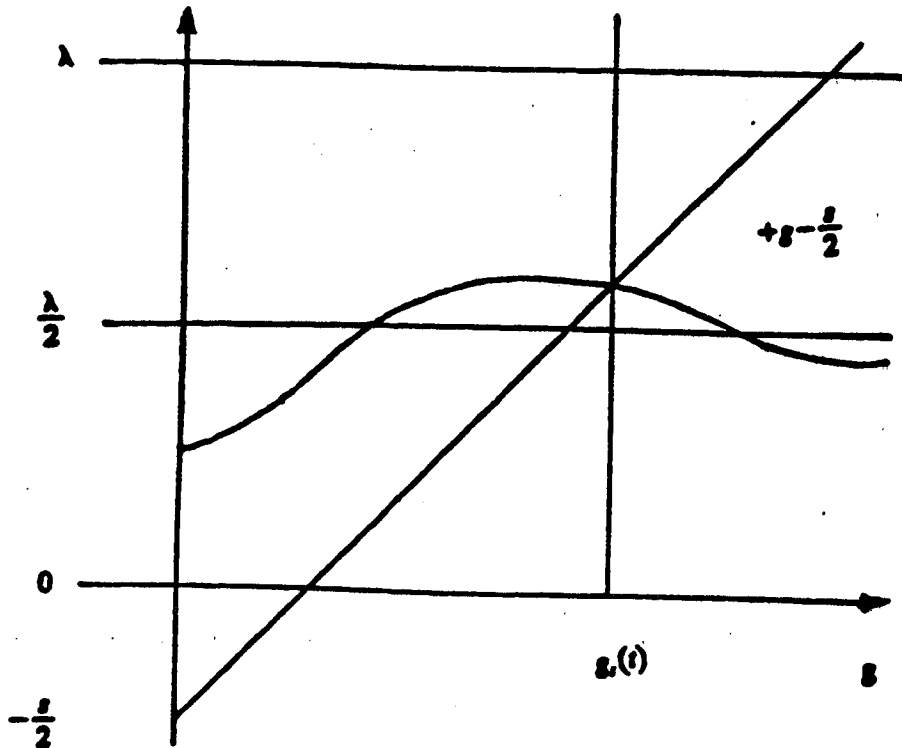

Figure 1

Owing to Lemma 1 and Lemma 2 , the kernel has exactly one root : which we shall denote as $g_s(t)$. This root is real and simple. The following properties of $g_s(t)$ will be of use later on (corollaries 1 to 3) :

Corollary 1

For $s > 0$, $g_s(t)$ satisfies the following properties:

$$(1.15) \quad g_s(t) = g_s(-t) \quad , t \in R;$$

$$(1.16) \quad 0 < g_s(t) \leq \lambda + \frac{s}{2} = \alpha_s, t \in R;$$

$$(1.17) \quad \lim_{s \rightarrow -\infty} g_s(t) = \frac{\lambda}{2} + \frac{s}{2}.$$

□

Proof

Equation (1.15) is a consequence of the symmetry property. The bounds (1.16) are obtained by construction (lemma 2) and the limit (1.17) is a consequence of condition (1.2).

Corollary 2

$$g_s(t) \geq g_s(0), t \in R.$$

□

Proof

Let us first prove that for any real t (the index k is omitted),

$$(1.18) \quad E [e^{-\sigma(X_1 + X_2)} \cos(t(X_1 - X_2))] \leq E [e^{-\sigma(X_1 + X_2)}].$$

If t is such that the L.H.S of (1.18) is negative, the inequality trivially satisfied. Otherwise,

$$\begin{aligned} E [e^{-\sigma(X_1 + X_2)} \cos(t(X_1 - X_2))] &= \\ |E [e^{-\sigma(X_1 + X_2)} \cos(t(X_1 - X_2))] | &\leq \\ E [| e^{-\sigma(X_1 + X_2)} \cos(t(X_1 - X_2)) |] &\leq \\ E [e^{-\sigma(X_1 - X_2)}] &. \end{aligned}$$

Hence

$$(1.19) \quad \begin{aligned} g_s(t) - \frac{s}{2} &= \frac{\lambda}{2} (1 - E [e^{-\sigma_s(t)(X_1 + X_2)} \cos t(X_1 - X_2)]) \\ &\geq \frac{\lambda}{2} (1 - E [e^{-\sigma_s(t)(X_1 + X_2)}]). \end{aligned}$$

Since the function

$$g \rightarrow \frac{\lambda}{2} (1 - E[e^{-g(x_1 + x_2)}])$$

is increasing, one can conclude from (1.19) that necessarily $g_s(t) \geq g_s(0)$ (see Figure 2).

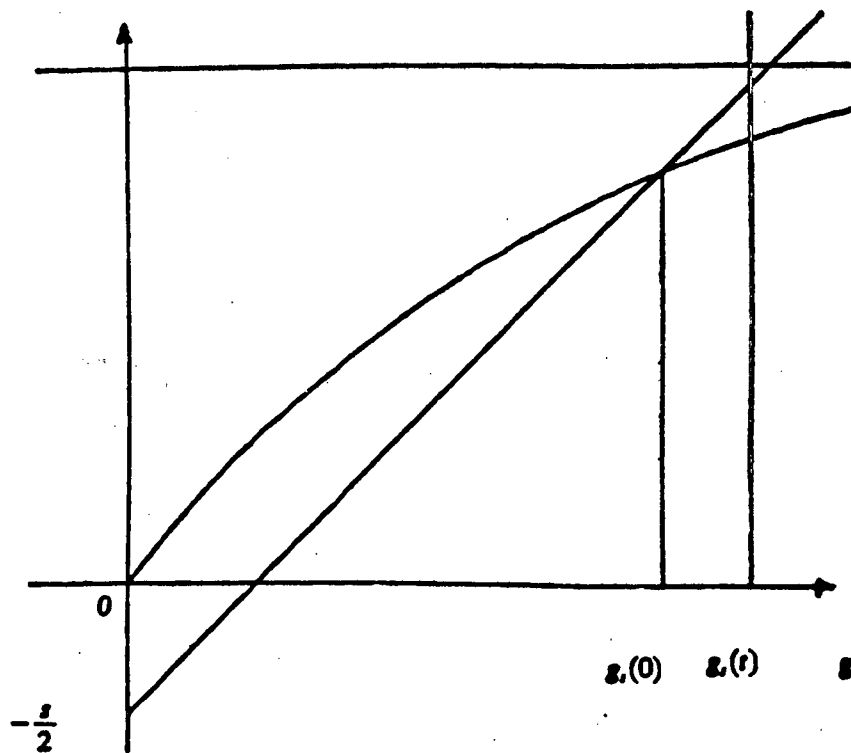

Figure 2

Corollary 3

$$(1.20) \quad \lim_{|k| \rightarrow \infty} \frac{d}{dt} g_s(t) \equiv \dot{g}_s(t) = 0. \quad \square$$

Proof

Differentiating with respect to t the identity $\Theta_s(g_s(t) + it, g_s(t) - it) = 0$, we get:

$$(1.21) \quad \dot{g}_s(t) = \frac{\frac{\lambda}{2} E[(X_1 - X_2) \sin(t(X_1 - X_2)) \exp(-g_s(t)(X_1 + X_2))]}{1 - \frac{\lambda}{2} E[(X_1 + X_2) \cos(t(X_1 - X_2)) \exp(-g_s(t)(X_1 + X_2))]}$$

Lemma 1 shows that $g_s(t)$ is an isolated and simple root of θ_s , so that

$\frac{\delta}{\delta g} \Theta_s(g + it, g - it) |_{g = g_s(t)}$ should be different from zero. This entails that the denominator of (1.21) does not vanish. (It is always positive).

Notice furthermore that due to our assumption (1.2) on Φ , the following limits exist:

$$\lim_{|k| \rightarrow \infty} \frac{\delta}{\delta g} \theta(g + it, g - it) = 0$$

$$\lim_{|k| \rightarrow \infty} \frac{\delta}{\delta t} \theta(g + it, g - it) = 0.$$

This together with the property (1.17) of corollary 1 can be used to prove that we have the following limits:

$$\lim_{|k| \rightarrow \infty} E[(X_1 - X_2) \sin(t(X_1 - X_2)) e^{-g_s(t)(X_1 + X_2)}] = 0$$

$$\lim_{|k| \rightarrow \infty} E[(X_1 + X_2) \cos(t(X_1 - X_2)) e^{-g_s(t)(X_1 + X_2)}] = 0.$$

Hence the following limit hold:

$$\lim_{|k| \rightarrow \infty} \dot{g}_s(t) = 0.$$

□

Remarks

— Equation (1.20) will be important in the next section. Notice that (1.2) is a sufficient condition for (1.10) to hold and that a weaker sufficient condition could be:

$$(1.23) \quad \lim_{|k| \rightarrow \infty} E [(X_1 - X_2) \sin(t(X_1 - X_2)) e^{-\sigma_s(t)(X_1 + X_2)}] = 0.$$

— Owing to equation (1.20), $|\dot{g}_s(t)|$ has a finite maximum when t traverses the real line. Using (1.21) together with the bound of corollary 2, we get the upper bound:

$$(1.24) \quad \sup_{t \in \mathbb{R}} |\dot{g}_s(t)| \leq \frac{\lambda E[(X_1 + X_2) e^{-\sigma_s(0)(X_1 + X_2)}]}{2 - \lambda E[(X_1 + X_2) e^{-\sigma_s(0)(X_1 + X_2)}]} \equiv \beta_s.$$

1.3.2 THE STATIONARY CASE

The Kernel in that case is the function

$$(1.25) \quad \theta(s_1, s_2) = s_1 + s_2 - \lambda(1 - \Phi(s_1, s_2)).$$

Looking for zeros having the form indicated in equation (1.11), we get:

Lemma 3

Assume that $\rho = \lambda E[X_1^t] = \lambda E[X_2^t] < 1$. If t is a fixed real number, the equation of unknown g : $\theta(g + it, g - it) = 0$ has a unique solution $g_o(t)$ in the domain $\text{Re}(g) \geq 0$. This solution is real and non negative. The part of the proof related to lemma 2 can be continued without changes, but for the case where $t = 0$. For this case, one sees that $g = 0$ is a real solution. The part of the proof related to lemma 1 can be continued for $t \neq 0$ without changes. For $t = 0$, notice first that for $\text{Re}(g) \geq 0$ and due to the stability condition,

$$(1.26) \quad \left| \frac{d}{dg} \frac{\lambda}{2} (1 - \Phi(g, g)) \right| < 1.$$

So that for any h such that $\text{Re}(h) \geq 0$, we have

$$\left| \frac{\lambda}{2} (1 - \phi(h, h)) \right| = \left| \int_0^h \frac{d}{dg} \frac{\lambda}{2} (1 - \phi(g, g)) dg \right| < \left| \int_0^h dg \right| < |h|.$$

This proves readily that the equation $\theta(g, g) = 0$ has no other solution than $g = 0$. □

We quote now some properties of $g_0(t)$ to be used later on. The proofs are very similar to the proofs for $s > 0$ and will therefore be omitted.

Corollary 1

The function $g_0(t)$ satisfies the following properties:

$$(1.27) \quad g_0(t) = g_0(-t), \quad t \in R;$$

$$(1.28) \quad 0 \leq g_0(t) < \lambda, \quad t \in R;$$

$$(1.29) \quad \lim_{|t| \rightarrow \infty} g_0(t) = \frac{\lambda}{2};$$

$$(1.30) \quad g_0(t) \geq g_0(0), \quad t \in R;$$

$$(1.31) \quad \lim_{|t| \rightarrow \infty} \dot{g}_0(t) = 0.$$

$$(1.32) \quad |\dot{g}_0(t)| \leq \beta_0 \equiv \frac{\rho}{1-\rho}.$$

□

II. THE CONFORMAL MAPPING

Let s be a fixed real number, $s \geq 0$. Consider the infinite arc of the right half plane defined by the parametric representation:

$$(2.1) \quad A_s = \{g_s(t) + it, t \in \mathbb{R}\}.$$

A_s is smooth (see equation (1.27) and (1.22)). The aim of the present section is to find a convenient conformal mapping from the domain A_s^+ , located on the right of the arc A_s , onto the unit circle. The use of this mapping will only become apparent in the next section.

We proceed in two steps. The first one consists of mapping conformally A_s^+ onto a bounded domain. The second one will consist of mapping conformally this second bounded domain onto the unit circle.

II.1 FIRST STEP

Let $\nu_s(u)$ be the conformal mapping of the right half plane onto the unit circle defined by :

$$(2.2) \quad \nu_s(u) = \frac{a_s u - 1}{a_s u + 1}, \quad u \in \mathbb{C},$$

where a_s is a real positive parameter (to be fixed later on) satisfying the constraint:

$$(2.3) \quad 0 < a_s < g_s(0)^{-1}.$$

Lemma 4

The mapping of the infinite arc A_s by the function ν_s is a bounded and smooth contour S_s , located inside the unit circle and such that $0 \in S_s^+$, the interior of S_s .

Proof

Owing to the fact that A_s is a smooth arc and ν_s a conformal mapping, the only problem which arises is for the point at infinity. In order to get a suitable representation, let us define $t(\theta) \in \mathbb{R}$ as follows:

$$t(\theta) = -i \frac{1 + \exp(i\theta)}{1 - \exp(i\theta)}, \theta \in (0, 2\pi),$$

and consider the curve S_s defined by :

$$(2.4) \quad S_s = \{ \nu_s(it(\theta) + g_s(t(\theta))), \theta \in [0, 2\pi] \}.$$

Let $x(\theta)$ and $y(\theta)$ denote the real and imaginary parts of the curve S_s :

$$(2.5) \quad \begin{cases} x(\theta) = a_s^2 \frac{g_s^2(t(\theta)) - 1 + a_s^2 t^2(\theta)}{(a_s g_s(t(\theta)) + 1)^2 + a_s^2 t^2(\theta)} \\ y(\theta) = \frac{2 a_s t(\theta)}{(a_s g_s(t(\theta)) + 1)^2 + a_s^2 t^2(\theta)} \end{cases}$$

Notice first that

$$(2.6) \quad \begin{cases} x(0^+) = x(2\pi^-) = 1 \\ y(0^+) = y(2\pi^-) = 0, \end{cases}$$

proving that S_s is actually a contour. (There are no other double point since ν_s is a conformal mapping and A_s has no double points). This curve is located inside the unit circle because A_s is on the right of $\text{Re}(u) \geq g_s(o)$ (Corollary 2 of lemma 2). We summarize our knowledge on S_s in Figure 3.

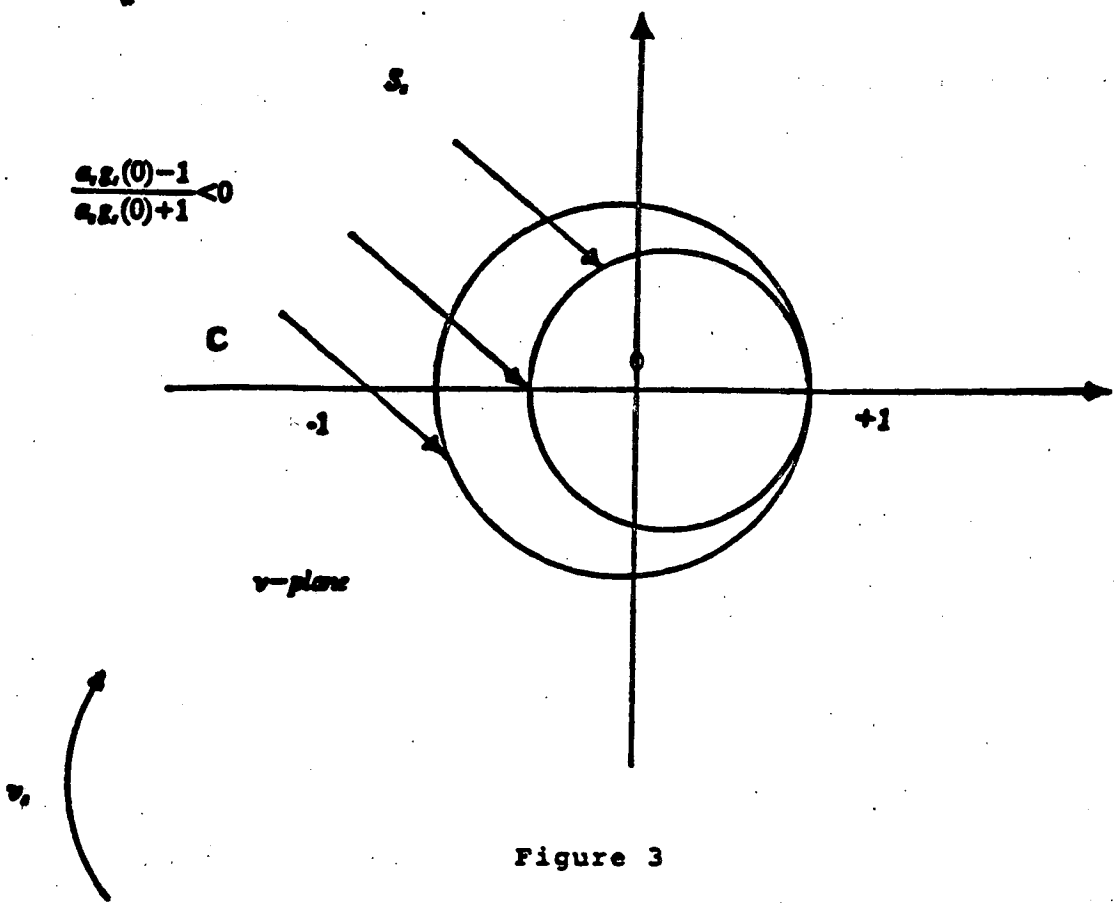
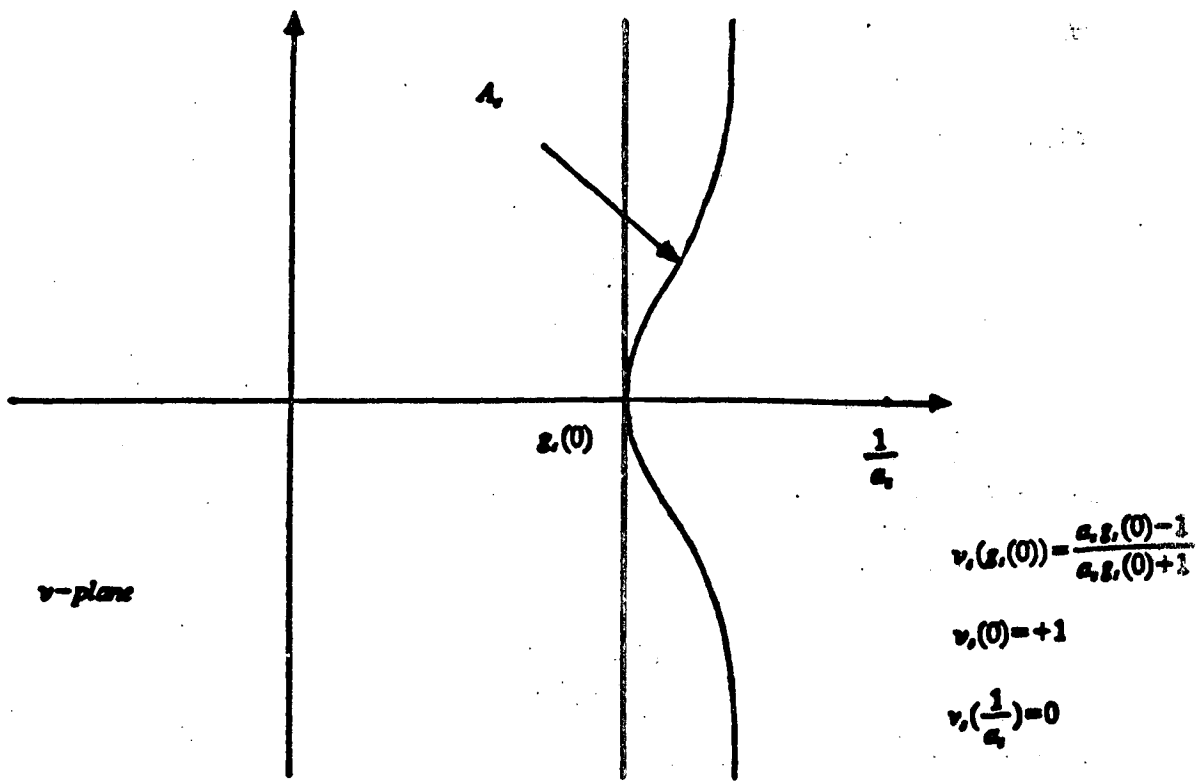

Figure 3



$$v_1(z_0) = \frac{a_1 z_0 - 1}{a_1 z_0 + 1}$$

$$v_1(0) = +1$$

$$v_1\left(\frac{1}{a_1}\right) = 0$$

In order to prove the smoothness of the contour S_θ for $\theta = 0$ it is necessary and sufficient to show that

$$(2.7) \quad \begin{cases} \dot{x}(0^+) = \dot{x}(2\pi^-) \\ \dot{y}(0^+) = \dot{y}(2\pi^-) \end{cases}$$

let

$$(2.8) \quad \begin{cases} \dot{x}(t) = \frac{a_\theta^2 g_\theta(t)^2 - 1 + a_\theta^2 t^2}{(a_\theta g_\theta(t) + 1)^2 + a_\theta^2 t^2} \\ \dot{y}(t) = \frac{2a_\theta t}{(a_\theta g_\theta(t) + 1)^2 + a_\theta^2 t^2} \end{cases}$$

Notice that $\dot{x}(t) = \dot{x}(-t)$ and $-\dot{y}(t) = \dot{y}(-t)$ so that $\dot{y}(t) = \dot{y}(-t)$ and $\dot{x}(t) = -\dot{x}(-t)$. Hence (2.7) holds for y and will hold for x if and only if :

$$(2.9) \quad \dot{x}(\infty)t(0) = 0.$$

To check this, notice that

$$t(\theta) = \frac{\sin\theta}{1-\cos\theta}$$

$$\dot{t}(\theta) = \frac{1}{\cos\theta - 1}$$

so that $t(\theta) \sim t(\theta)^2$ when $\theta \rightarrow 0$. Furthermore, when $t \rightarrow \infty$, we have :

$$\dot{x}(t) = \frac{4a_\theta^3 t^2 g_\theta(t) + 0(t^2)}{((a_\theta g_\theta(t) + 1)^2 + a_\theta^2 t^2)^2}$$

so that the contour is also smooth at $\theta = 0$ (Corollary 3 of lemma 2).

Lemma 5

If the constant a , satisfies the constraint

$$(2.10) \quad \alpha_s \leq \alpha_s^{-1}(\beta_s^2 + 1)^{-\frac{1}{2}},$$

then, $\phi_s(t) = \arg(x(t)) + i \dot{y}(t)$ is a strictly decreasing function. □

Proof

From equation (2.8) we get :

$$(2.11) \quad \operatorname{tg}(\phi_s(t)) = \frac{2a_s t}{a_s^2 g_s^2(t) + a_s^2 t^2 - 1},$$

so that

$$(2.12) \quad \begin{aligned} \phi_s(t) &= 2a_s \cos^2(\phi_s(t)) \frac{a_s^2(g_s^2(t) - t^2 - 2\operatorname{tg}_s(t)\dot{g}_s(t)) - 1}{(a_s^2(g_s^2(t) + t^2) - 1)^2} \\ &= [4a_s^2 t^2 + (a_s^2(g_s^2(t) + t^2) - 1)^2]^{-1} [a_s^2(g_s^2(t) - t^2 - 2\operatorname{tg}_s(t)\dot{g}_s(t)) - 1]. \end{aligned}$$

Notice first that owing to equation (2.3), the function

$$t \rightarrow [4a_s^2 t^2 + (a_s^2(g_s^2(t) + t^2) - 1)^2]$$

is strictly positive for $t \in \mathbb{R}$. Furthermore, the function $t \rightarrow f_s(t) = a_s^2(g_s^2(t) - t^2 - 2\operatorname{tg}_s(t)\dot{g}_s(t)) - 1$ is pair. Using the upper bounds of equations (1.16) and (1.24), we get thus:

$$f_s(t) < \sup_{t > 0} (\alpha_s^2 - t^2 + 2t\alpha_s\beta_s),$$

so that finally:

$$f_s(t) < \alpha_s^2(1 + \beta_s^2) \equiv \gamma_s^2 \quad \text{for } t \in R.$$

Accordingly, if one takes a_s such that $a_s \leq \gamma_s^{-1}$, equation (2.12) shows that $\phi_s(t)$ is strictly negative for any $t \in R$, which completes the proof of the lemma. \square

Notice that if $a_s > 0$ satisfies equation (2.10), it satisfies a fortiori equation (2.3). In the sequel, a_s will be chosen to be equal to γ_s^{-1} :

$$(2.13) \quad a_s = \gamma_s^{-1} = \gamma_s^{-1}(\beta_s^2 + 1)^{-\frac{1}{2}}.$$

II.2 SECOND STEP

Owing to lemma 5, the function

$$t \rightarrow \phi_s(t)$$

is strictly decreasing and therefore invertible. We shall denote its inverse by $\tau_s: [0, 2\pi] \rightarrow R$.

Accordingly, the curve S_s has the following parametric representation:

$$S_s = \{e^{i\theta} k(s, e^{i\theta}), \theta \in [0, 2\pi]\},$$

where

$$(2.14) \quad k(s, e^{i\theta}) = ((x(\tau_s(\theta)))^2 + (y(\tau_s(\theta)))^2)^{\frac{1}{2}} \leq 1.$$

Such a parametric representation is the right one for determining simply the conformal transformation $p_s(z)$ mapping the unit disc C^+ onto the interior of $S_s: S_s^+$, as well as the

function $q_s(z)$ mapping the exterior of the unit disc C^- onto S_s^+ :

Lemma 6

The conformal mappings $p_s(z)$ and $q_s(z)$ subject to the conditions $p_s(0) = 0, q_s(\infty) = 0$ and

$\frac{d}{dz} p_s(z)|_0 > 0, \frac{d}{dz} q_s(z)|_\infty > 0$, are given by:

$$(2.15) \quad p_s(z) = z \exp\left\{\frac{1}{2i\pi} \int_{|s|=1} \log(k(s, \exp(i\lambda_s(u)))) \frac{u+z}{u-z} \frac{du}{u}\right\}, |z| < 1,$$

$$(2.16) \quad q_s(z) = z^{-1} \exp\left\{\frac{-1}{2i\pi} \int_{|s|=1} \log(k(s, \exp(i\lambda_s(u)))) \frac{u+z}{u-z} \frac{du}{u}\right\}, |z| > 1,$$

where $\lambda_s(z), |z| = 1$ is the unique real and continuous solution of Theodorsen's singular integral equation:

$$(2.17) \quad \lambda_s(\exp(i\phi)) = \phi - \frac{1}{2\pi} \int_0^{2\pi} \log(k(s, \exp(i\lambda_s(\exp i\omega)))) \cotg\left(\omega - \frac{\phi}{2}\right) d\omega.$$

Proof

This is Theodorsen's theorem (see [23 p. 70]). □

Applying Plemelj - Sokhotski formulae to (2.15) and (2.16), we get the following limit properties:

Corollary 1

For z_0 such that $|z_0| = 1$, we have:

$$(2.18) \quad \lim_{z \rightarrow z_0 \text{ in } C^+} p_s(z) \equiv p_s^+(z_0) = e^{i\lambda_s(z_0)} k(s, e^{i\lambda_s(z_0)})$$

and

$$(2.19) \quad \lim_{z \rightarrow z_0 \text{ in } C^-} q_s(z) \equiv q_s^-(z_0) = e^{i\lambda_s(z_0)} k(s, e^{i\lambda_s(z_0)}). \quad \square$$

Corollary 2

$$(2.20) \quad |p_s(z)| \leq 1 \text{ for } |z| \leq 1.$$

and

$$(2.21) \quad |q_s(z)| \leq 1 \text{ for } |z| \geq 1. \quad \square$$

Proof

Use equations (2.14), (2.18) and (2.19) and the maximum principle. \square

We shall denote as σ_s the inverse function of ν_s , and as r_s (resp. t_s) the inverse function of p_s (resp. q_s). Notice that $p_s(t) = q_s(\frac{1}{t})$ for $|z| < 1$ so that

$$(2.22) \quad \begin{aligned} \sigma_s(p_s(C^+)) &= A^+, \\ \sigma_s(q_s(C^-)) &= A^+ . \end{aligned}$$

We summarize the diverse mappings introduced in this section in figure 4.

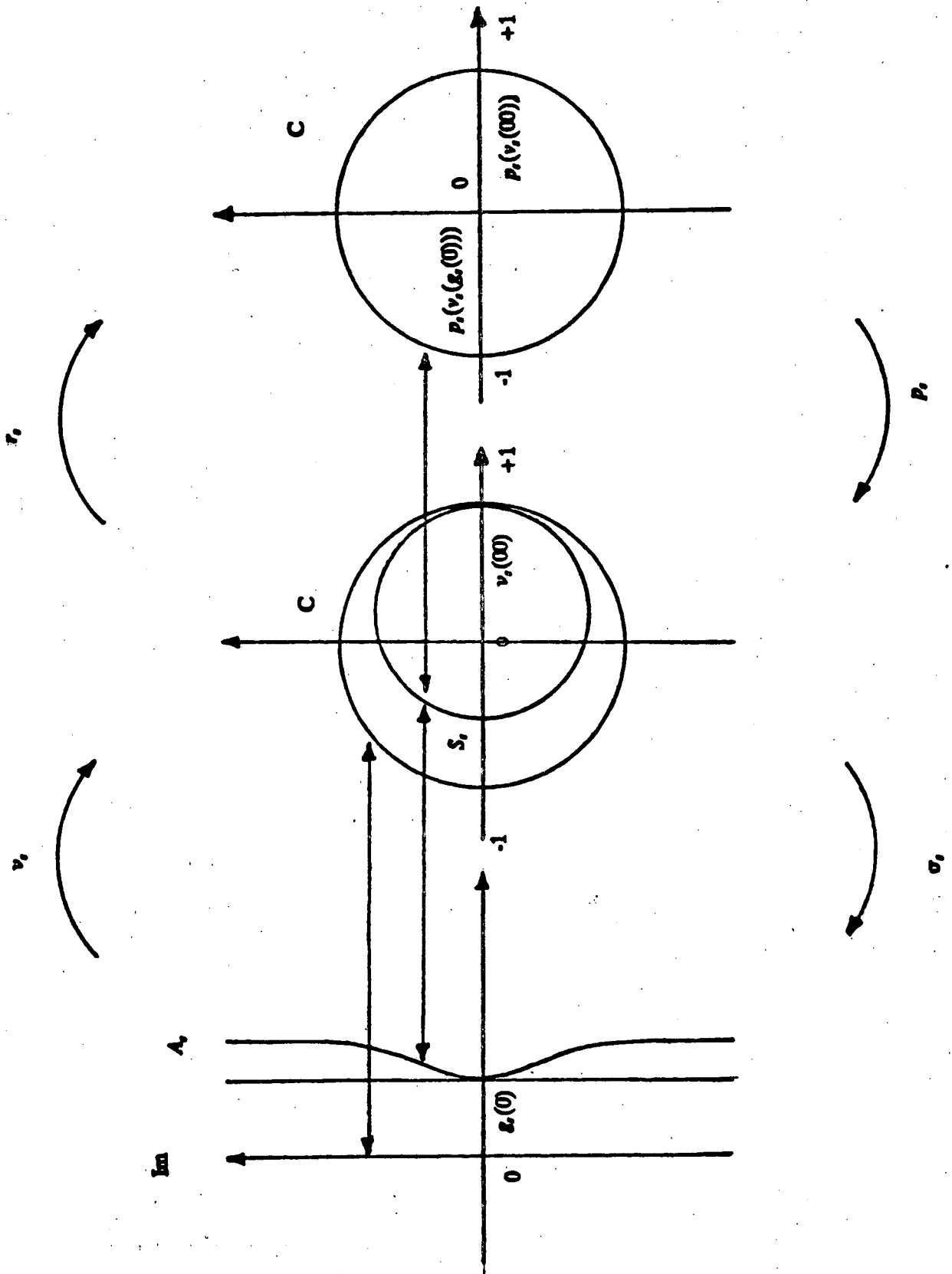

Figure 4

III. POSITION OF THE BOUNDARY VALUE PROBLEMS.

Equations (1.8) and (1.9) show that the problem can be considered as solved if one determines the functions $\Psi_{i,s}$ and $\Psi_i, i = 1,2$. This determination is the aim of the present section.

III.1 THE TRANSIENT CASE

We can rewrite the functional equation (1.8) for the transient case as follows:

$$(3.1) \quad \begin{aligned} & [\sigma_s(u_1) + \sigma_s(u_2) - \lambda(1 - \Phi(\sigma_s(u_1), \sigma_s(u_2))) - s]P_s(u_1, u_2) \\ & = \sigma_s(u_2) P_s^1(u_1) + \sigma_s(u_1) P_s^2(u_2) - R_s(u_1, u_2), \end{aligned}$$

where $|u_1| \leq 1, |u_2| \leq 1$ and

$$(3.2) \quad \begin{aligned} P_s(u_1, u_2) & \equiv \Psi_s(\sigma_s(u_1), \sigma_s(u_2)), \\ P_s^i(u_i) & \equiv \Psi_{i,s}(\sigma_s(u_i)), i=1,2 \text{ and} \\ R_s(u_1, u_2) & = \Psi(o, \sigma_s(u_1), \sigma_s(u_2)) . \end{aligned}$$

Taking $u_1 = p_s^+(z_0)$ and $u_2 = q_s^-(z_0)$, one sees from (2.18) and (2.19) that these two complex numbers are complex conjugate and located on the curve S_s . Therefore $\sigma_s(u_1)$ and $\sigma_s(u_2)$ are on the curve A_s and are of the form:

$$(3.3) \quad \begin{aligned} \sigma_s(u_1) & = g_s(t_0) + it_0, \\ \sigma_s(u_2) & = g_s(t_0) - it_0, \end{aligned}$$

for $t_0 = \tau_s(\lambda_s(z_0))$ (where τ_s denotes the inverse of ϕ_s , see lemma 5 and the following remarks).

Accordingly, the L. H. S of (3.2) vanishes providing the following key relationship (after division

Accordingly, the L. H. S of (3.2) vanishes providing the following key relationship (after division by $\sigma_s(q_s^-(z)) \cdot \sigma_s(p_s^+(z))$):

$$(3.4) \quad \frac{\Psi_{1,s}(\sigma_s(p_s^+(z)))}{\sigma_s(p_s^+(z))} + \frac{\Psi_{2,s}(\sigma_s(q_s^-(z)))}{\sigma_s(q_s^-(z))} = d_s(z) ,$$

for $|z| = 1$, when denoting as $d_s(z)$ the function

$$(3.5) \quad d_s(z) = \frac{R_s(p_s^+(z), q_s^-(z))}{\sigma_s(p_s^+(z)) \cdot \sigma_s(q_s^-(z))} , |z| = 1.$$

Lemma 7

The function $\psi_{1,s}(\sigma_s(p_s^+(z)))/\sigma_s(p_s^+(z))$ (resp. $\psi_{2,s}(\sigma_s(q_s^-(z)))/\sigma_s(q_s^-(z))$) is the limiting value from inside (resp. from outside) of a function analytic in C_+ (resp C^-) and continuous in $C^+ \cup C$ (resp $C^- \cup C$). □

Proof:

This function is the ration $\psi_{1,s}(\sigma_s(p_s(z)))/\sigma_s(p_s(z))$ (resp. $\psi_{2,s}(\sigma_s(q_s(z)))/\sigma_s(q_s(z))$). The analycity in C^+ (resp. C^-) is a consequence of the property : $0 \notin A_{s,+}$ for $s > 0$ (see (2.23) and (2.24)). Since $p_s(z) \rightarrow p_s^+(z)$ and $q_s(z) \rightarrow q_s^-(z)$, the assertion relative to continuity is straight forward for any point of continuity of $\psi_{1,s} \circ \sigma_s / \sigma_s$ and $\psi_{2,s} \circ \sigma_s / \sigma_s$. The only problem that could arise is for point 1 where σ_s is discontinuous, having a pole of order 1. But since $\Psi_{i,s}$ is bounded in the right half plane, the following limit holds:

$$(3.6) \quad \lim_{z \rightarrow 1} \frac{\psi_{i,s}(\sigma_s(z))}{\sigma_s(z)} = 0, \quad i = 1, 2,$$

so that point 1 is a point of continuity as well. □

Equation (3.3) can accordingly be rewritten as the following basic boundary value problem on the unit circle:

Let Λ_s be the function defined in $C^+ \cup C^-$ by

$$(3.7) \quad \begin{cases} \Lambda_s(z) = \frac{\psi_{1,s}(\sigma_s(p_s(z)))}{\sigma_s(p_s(z))} + a_s \psi_{2,s}\left(\frac{1}{a_s}\right), |z| < 1 \\ \Lambda_s(z) = \frac{-\psi_{2,s}(\sigma_s(q_s(z)))}{\sigma_s(q_s(z))} + a_s \psi_{2,s}\left(\frac{1}{a_s}\right), |z| > 1 \end{cases}$$

From Lemma 7, Λ_s is analytic in C^+ (resp. C^-) and continuous in $C^+ \cup C$ (resp. $C \cup C^-$). Equation (3.3) shows that it furthermore satisfies the boundary condition:

$$(3.8) \quad \Lambda_s^+(z) - \Lambda_s^-(z) = d_s(z), \quad |z| = 1.$$

This is a basic boundary value problem which provides the following analytic characterization:

Lemma 8

$$(3.9) \quad \psi_{1,s}(\sigma_s(p_s(z))) = \frac{\sigma_s(p_s(z))}{2i\pi} \int_{|t|=1} \frac{d_s(t)}{t-z} dt + a_s \sigma_s(p_s(z)) \Psi_{2,s}\left(\frac{1}{a_s}\right), |z| < 1,$$

and

$$(3.10) \quad \psi_{2,s}(\sigma_s(q_s(z))) = -\frac{\sigma_s(q_s(z))}{2i\pi} \int_{|t|=1} \frac{d_s(t)}{t-z} dt + a_s \sigma_s(q_s(z)) \Psi_{2,s}\left(\frac{1}{a_s}\right), |z| > 1.$$

□

Using the properties $p_s(z) = q_s(\frac{1}{z})$, one checks that if the initial condition is symmetrical ($d_s(t) = d_s(\bar{t})$), $\psi_{1,s} = \psi_{2,s}$, at least in A_s^+ , and therefore everywhere in the right half plane, which was expected due to the symmetry of the problem.

Theorem 1

Let r_s denote the inverse function of p_s . In the case of symmetrical initial conditions, the functions $\psi_{1,s}$ and $\psi_{2,s}$ are given by the cauchy integrals:

$$(3.11) \quad \Psi_{1,s}(s_1) = \frac{s_1}{2i\pi} \int_{|k|=1} d_s(t) \left[\frac{1}{t-r_s(\nu_s(s_1))} - \frac{1}{2t} \right] dt$$

$$(3.12) \quad \psi_{1,s}(s_1) = \psi_{2,s}(s_1) \quad \square$$

Proof

Equation (3.11) is obtained from (3.9) after determining the unknown constant $\psi_{1,s}(\frac{1}{a_s})$ (Write

(3.9) at $z = 0$.) Equation (3.12) is obtained from the above remark. \square

III.2 THE STATIONARY CASE

In this section, it will be assumed that $\theta(s_1, s_2)$ is analytic at point (0,0). The equivalent of equation (3.3), after multiplication by $(1+z)$, reads:

$$(3.13) \quad (1+z) \frac{\Psi_1(\sigma_o(p_o^+(z)))}{\sigma_o(p_o^+(z))} + (1+z) \frac{\Psi_2(\sigma_o(q_o^-(z)))}{\sigma_o(q_o^-(z))} = 0, \quad |z| = 1.$$

Here again, we can reduce the problem to the determination of a function Λ_o analytic in C^+ ,

Here again, we can reduce the problem to the determination of a function Λ_o analytic in C^+ , continuous in $C^+ \cup C$, analytic in C^- , continuous in $C^- \cup C$ and satisfying a simple boundary condition. Let

$$(3.14) \quad \Lambda_o(z) = \frac{(1+z)\psi_1(\sigma_o(p_o(z)))}{\sigma_o(p_o(z))}, |z| < 1,$$

$$(3.15) \quad \Lambda_o(z) = -\frac{(1+z)\psi_2(\sigma_o(q_o(z)))}{\sigma_o(q_o(z))}, |z| > 1.$$

The only zero of $\sigma(p_o(z))$ and $\sigma(q_o(z))$ is for $z = -1$ and it is compensated by the zero of $(1+z)$. To show this, notice first that our assumption of analyticity of θ at $(0,0)$ entails the regularity of the functions $p_o(z), q_o(z)$ and $\lambda_o(z)$ for $|z| = 1$ (see [2] pp 136 and following). Hence

$$(3.16) \quad \lim_{z \rightarrow -1} \frac{1+z}{\sigma_o(p_o(z))} = \lim_{|z|=1} \frac{1+z}{\sigma_o(p_o^+(z))} \\ = a_o / (2 \frac{d}{dz} P_o^+(z) |_{z=-1}) = a_o / (2i \frac{d}{dt} \lambda_o(z) |_{z=-1}).$$

The strict increasingness of $\lambda_o(z)$ ([2] p 73) shows that the following limit exists:

$$(3.17) \quad \lim_{z \rightarrow -1} \frac{1+z}{\sigma_o(p_o(z))} = \text{constant},$$

which entails that the function Λ_o has the announced regularity property. Equation (3.11) shows furthermore that the two functions $\Lambda_o(z), |z| < 1$ and $\Lambda_o(z), |z| > 1$ are each other's analytic continuation. Since $\Lambda_o(z)$ has a pole of order one at infinity, the solution of the problem is obtained from Liouville's theorem:

$$(3.18) \quad \begin{aligned} \psi_1(\sigma_o(p_o(z))) &= \frac{\gamma + \delta z}{1+z} \sigma_o(p_o(z)) \quad |z| < 1, \\ \psi_2(\sigma_o(q_o(z))) &= -\frac{\gamma + \delta z}{1+z} \sigma_o(q_o(z)), \quad |z| > 1, \end{aligned}$$

where γ and δ are two constant to be determined. A first relationship between these constants is obtained when noticing that $\psi_1 = \psi_2$ and that $p_o(z) = q_o(\frac{1}{z})$, for $|z| < 1$, so that necessarily :

$$(3.19) \quad \gamma = -\delta$$

Hence, the solution of the problem can be rewritten as follows:

$$(3.20) \quad \psi_1(s) = \gamma s_1 \frac{1 - r_o(\nu_o(s_1))}{1 + r_o(\nu_o(s_1))}, \quad s_1 \in A_o^+$$

We thus remain with the problem of determining the unknown constant γ . Since

$$(3.21) \quad \Psi(s_1, s_2) = \frac{s_1 \Psi_2(s_2) + s_2 \Psi_1(s_1)}{s_1 + s_2 - \lambda(1 - \Phi(s_1, s_2))},$$

we have:

$$(3.22) \quad \Psi(s_1, 0) = \frac{s_1 \Psi_2(0)}{s_1 - \lambda(1 - \Phi(s_1, 0))}$$

This is the Pollaczek - Khinchine formula and proves that $\Psi_2(o) = 1 - \rho = 1 - \lambda E[X_1]$. Owing to

(3.20), we get:

$$(3.23) \quad 1 - \rho = \Psi_1(o) = \frac{\gamma \cdot a_0}{\frac{d}{ds} r_o(s)|_{-1}} = a_0 \cdot \gamma \frac{d}{dz} p_o(z)|_{-1}$$

so that γ is given by the formula

$$(3.24) \quad \gamma = i(1-\rho) / (a_0 \frac{d}{dz} \lambda_0(z)|_{z=-1}).$$

This completes the analytical characterization of the solution, at least in the domain $s_1 \in A_0^+, s_2 \in A_0^+$.

Theorem 2

For s_1 in the domain A_0^+ , the functions Ψ_1 and Ψ_2 are given by

$$(3.24) \quad \begin{cases} \Psi_1(s_1) = \gamma s_1 \frac{1-r_0(\nu_0(s_1))}{1+r_0(\nu_0(s_1))} \\ \Psi_2(s_1) = \Psi_1(s_1) \end{cases}$$

where the constant γ is determined by equation (3.24). □

IV. ANALYTIC CONTINUATION.

The aim of this section is to continue the analytic characterization of $\Psi_{1,s}$ (resp. Ψ_1) obtained in theorem 1 (resp. theorem 2) from the domain A_s^+ (resp. A_0^+) onto the whole right half plane.

IV.1 THE TRANSIENT CASE.

The function $g_s(t)$ is analytic for any $t \in \mathbb{R}$, so that the contour S_s is an analytic contour (but possibly at point 1). This entails that the function r_s (the inverse of p_s), which is analytic in S_s^+ and continuous in $S_s^+ \cup S_s$, can be continued analytically across the boundary S_s (but possibly across point 1). More precisely, the following lemma holds:

Lemma 9

The function r_s can be continued as a function regular in the domain C^+ , and continuous in $C^+ \cup C$. □

Proof

Lemma (8.3) p. 113 in [2] together with the adaptation of lemma (8.1) p. 110 in [2] to the present situation (see lemma 1) . □

In the sequel, we shall denote by the same symbol the function r_s and its analytic continuation.

Theorem 3

The assumptions are those of theorem 1. Let $\epsilon_s(s_1)$ be the function $: \text{Re}(s_1) \geq 0 \rightarrow \mathbb{R}$ defined by :

$$(4.1) \quad \begin{cases} \epsilon_s(s_1) = 0, \text{ for } s_1 \in A_s^+, \\ \epsilon_s(s_1) = \frac{1}{2}, \text{ for } s_1 \in A_s, \text{ and} \\ \epsilon_s(s_1) = 1, \text{ for } s_1 \in A_s^- \cap \{\operatorname{Re}(s_1) \geq 0\}. \end{cases}$$

For any s_1 with a positive real part, $\Psi_{1,s}(s_1)$ is given by:

$$(4.2) \quad \Psi_{1,s}(s_1) = \frac{s_1}{2i\pi} \int_{|k|=1} d_s(t) \left[\frac{1}{t - r_s(r_s(\nu_s(s_1)))} - \frac{1}{t} \right] dt + \epsilon_s(s_1) \cdot \frac{\Psi(0, s_1, \sigma_s(q_s(r_s(\nu_s(s_1)))))}{\sigma_s(q_s(r_s(\nu_s(s_1))))}$$

(where the singular cauchy integral, when $s_1 \in A_s$, is understood in principal value.) Furthermore

$$\Psi_{1,s} = \Psi_{2,s}.$$

□

Proof

For $s_1 \in A_s^+$, equation (4.2) is nothing more than equation (3.11) of theorem 1. To establish (4.2) for $s_1 \in A_s$, apply Plemelj - Sokhotski formulae when letting s_1 go to $s_1 \in A_s$ in A_s^+ and notice that $\sigma_s(p_s^+(r_s(\nu_s(s_1)))) = s_1$.

Finally, the R. H. S of (4.2) is analytic in $A_s^- \cap \{\operatorname{Re}(s_1) \geq 0\}$ and continuous in $(A_s^- \cup A_s) \cap \{\operatorname{Re}(s_1) \geq 0\}$ and its limiting value when s_1 goes to $s_1 \in A_s$ in A_s^- is also $\Psi_{1,s}(s_1)$. (Owing to Plemelj - Sokhotski). This proves readily that the function $\Psi_{1,s}(s_1), s_1 \in (A_s^- \cup A_s) \cap \{\operatorname{Re}(s_1) \geq 0\}$ is actually the analytic continuation of the integral (3.11), which completes the proof of the theorem. □

IV.2 THE STATIONARY CASE

With the assumptions of section III.2, one proves as in the preceding case that the mapping r_s can be analytically continued from S_0^+ onto C^+ and we shall here again denote the original r_s

and its analytic continuations by the same symbol. With this notation, one sees readily that equation (3.24) of theorem 2 remains valid without change for any complex number s_1 with a positive real part.

ACKNOWLEDGMENT

I express my thanks to T. OTT for stating this problem and for his comments on the present paper.

BIBLIOGRAPHY

- {1} L. FLATTO and S. HAHN " Two parallel queues created by arrivals with two demands ". SIAM Journal APPL. Math. Vol. 44, No 5, October 1984.
- {2} J. W. COHEN and O. J. BOXMA " Boundary value problems in queuing system analysis " North Holland. Amsterdam, 1983.

Imprimé en France

par

l'Institut National de Recherche en Informatique et en Automatique

