



**HAL**  
open science

## Acyclic fork-join queueing networks

François Baccelli, W.A. Massey, D. Towsley

► **To cite this version:**

François Baccelli, W.A. Massey, D. Towsley. Acyclic fork-join queueing networks. RR-0688, INRIA. 1987. inria-00075865

**HAL Id: inria-00075865**

**<https://inria.hal.science/inria-00075865v1>**

Submitted on 24 May 2006

**HAL** is a multi-disciplinary open access archive for the deposit and dissemination of scientific research documents, whether they are published or not. The documents may come from teaching and research institutions in France or abroad, or from public or private research centers.

L'archive ouverte pluridisciplinaire **HAL**, est destinée au dépôt et à la diffusion de documents scientifiques de niveau recherche, publiés ou non, émanant des établissements d'enseignement et de recherche français ou étrangers, des laboratoires publics ou privés.

# INRIA

UNITE DE RECHERCHE  
INRIA-ROQUENCOURT

Institut National  
de Recherche  
en Informatique  
et en Automatique

Domaine de Voluceau  
Roquencourt  
BP 105  
78153 Le Chesnay Cedex  
France  
Tél. (1) 39 63 55 11

## Rapports de Recherche

N° 688

### ACYCLIC FORK-JOIN QUEUEING NETWORKS

François BACCELLI  
William A. MASSEY  
Don TOWSLEY

JUIN 1987

# ACYCLIC FORK-JOIN QUEUEING NETWORKS

March 1987

by

François BACCELLI <sup>1</sup>

William A. MASSEY <sup>2</sup>

Don TOWSLEY <sup>3</sup>

## ABSTRACT

In this paper we study the class of acyclic fork-join queueing networks that arise in various applications, including parallel processing and flexible manufacturing. In such queueing networks, a fork describes the simultaneous creation of several new customers which are sent to different queues. The corresponding join occurs when the services of all these new customers are completed. We derive the evolution equations that govern the behavior of such networks. From this, we obtain the stability conditions and develop upper and lower bounds on the network response times. These bounds are based on stochastic ordering principles and apply under general workload assumptions.

---

<sup>1</sup> INRIA B.P. 105 - 78153 Le Chesnay (France)

<sup>2</sup> ATT BELL LABORATORIES, Murray Hill - NJ - 07940 (U.S.A.)

<sup>3</sup> University of MASSACHUSETTS Amherst - MA - 01003 (U.S.A.)

**RESEAUX ACYCLIQUES DE FILES  
D'ATTENTE AVEC DES SYNCHRONISATIONS  
DE TYPE FORK-JOIN**

**François BACCELLI<sup>1</sup>, William A. MASSEY<sup>2</sup>, Don TOWSLEY<sup>3</sup>**

**Résumé**

Cet article étudie une classe de réseaux acycliques de files d'attente synchronisées qui apparaît dans de nombreuses applications dont l'algorithmique parallèle et la productique. Dans un tel réseau, un "Fork" décrit la création simultanée de plusieurs clients destinés à des files d'attente différentes. Le "Join" correspondant prend place lorsque les services de ces divers clients sont tous terminés. On établit les équations qui gouvernent l'évolution de ces réseaux. On en déduit les conditions de stabilité ainsi que des bornes supérieures et inférieures sur les temps de réponse. Ces bornes se fondent sur des méthodes d'ordonnancement stochastique et sont calculables lorsque les processus d'arrivée et de service sont de renouvellement.

---

<sup>1</sup> INRIA B.P. 105 - 78153 Le Chesnay (France)

<sup>2</sup> ATT BELL LABORATORIES, Murray Hill - NJ - 07940 (U.S.A.)

<sup>3</sup> University of MASSACHUSETTS Amherst - MA - 01003 (U.S.A.)

In this paper we study the class of *acyclic fork-join queueing networks*, in short "AFJQN's", that arise in the performance analysis of parallel processing applications and flexible manufacturing systems. We obtain the stability conditions and develop upper and lower bounds on the performance of this class of networks under very general workload assumptions.

AFJQN's arise very naturally in parallel processing applications. Many parallel programs are decomposed into tasks, each of which can execute on a separate processor. The division of the parallel program into tasks can be described by a directed graph where the nodes correspond to tasks and the directed edges represent the precedence relations between the tasks. In many cases, the underlying graph is acyclic and the program is implemented with the use of *fork* and *join* constructs. Briefly, a fork exists at each point in a parallel program that one or more tasks can be initiated simultaneously. A join occurs whenever a task is allowed to begin execution following the completion of one or more other tasks. Forks and joins reflect themselves in the underlying computation graph in the following manner. A task that has one or more outgoing edges corresponds to a fork. A task with one or more incoming edges corresponds to a join. These are exemplified by the *parbegin* and *parend* constructs that are available in parallel programming languages such as Concurrent Pascal [Br 75], Concurrent Sequential Processes (CSP)[Ho 78], and Ada [Py 81].

Consider a multiple processor system where each task in a specific program is mapped onto a separate processor. The execution of a single program request can be described as follows: (i) Upon completion of a marked task, tokens associated with the program are routed to each processor handling the tasks that follow the marked task in the underlying computation graph; (ii) Once a processor has received tokens from all tasks that precede a marked task in the computation graph, this processor is allowed to execute it. Let this system be required to service a stream of requests corresponding to different instances of that program and assume each processor executes its tasks in the order defined by the program arrival dates. We have described, in brief, an AFJQN. Figure 1a illustrates a hypothetical parallel program using forks and joins and Figure 1b illustrates the associated fork-join queueing network.

AFJQN's also arise naturally in the context of flexible manufacturing systems. In production lines, objects are built by assembling multiple parts together. The successive assembly steps are described by an acyclic graph where the nodes correspond to assembly operations and the edges to precedence constraints between these operations. Here, a join occurs whenever all the parts to be produced by the operations that precede a marked operation have to be available in order to begin assembling. A fork occurs at points where several assembly operations are initiated simultaneously ( for instance at points where the production of some part is followed in the underlying graph by several assembly operations to be done on this same part ). Assume each assembly operation is allocated to a specific machine. We have another instance of AFJQN when identifying assembly machines with the servers of the queueing network and the parts with its customers.

Apart from the subclass of Jackson series networks, the type of queueing networks we consider here remain basically unsolved. It can be shown that the "synchronisations" induced by the forks and the joins destroy all nice properties like insensitivity or product form, so that every problem becomes computationally hard. Initially, most attention focussed on fork-join networks consisting of  $B$  queues in parallel. In this case, exact solutions have been provided for  $B = 2$  in [FH 84] and [Ba 85]. Approximate solutions and bounds have been provided for arbitrary values of  $B$  in [BM 85], [NT 85], [TY 86] and [BMS 87]. Conditions for stability have been presented for arbitrary values of  $B$  in [BM 85] and [Si 87]. Last, models have been developed for programs exhibiting parallel fork-join structures that are executed on multiple processors serving a single queue in [KW 85] and [NTT 87]. Series-parallel Fork Join queueing networks have been introduced in [BM 85], where stability condition and bounds were derived.

Several classes of stochastic ordering principles have been considered in the queueing literature

( see [St 84] for a comprehensive treatment of the issue ). It was shown for instance, that an increased input ( resp. decreased output ) intensity leads to higher ( resp. reduced ) moments of the waiting or response times for wide classes of queueing systems ( see [Wh 81] ). Another type of ordering comes from the idea that an increased variability of either the input or the service statistics should also lead to higher waiting or response times. This has been discussed by several authors in the context of isolated queues ( see [St 84], [Ha 84], [Wh 84],[BM 85b] ). The latter ordering principle was used in [BM 85] ( resp. [BM 85b] ) to compare the moments of the delays experienced by customers traversing parallel ( resp. series-parallel ) fork-join queueing networks to the related moments of product form networks. Both upper and lower bounds were derived using this principle.

A third type of ordering arises when a set of random variables (RV's) are *associated*. In this case the statistics of the maximum over these RV's are bounded by the maximum of the marginals of these RV's . This approach was used in [NT 85] and [BMS 87] to develop upper bounds on the moments of the delays experienced by customers traversing a parallel fork-join network.

The aim of this paper is to extend the scope of these ordering and bounding techniques to the class of arbitrary AFJQN's which are rigorously defined in Section 2. The equations governing the behavior of these networks are provided in Section 3. This section also contains necessary and sufficient conditions for the stability of these networks under fairly general statistical assumptions. This stability result is based on an extension of Loynes' method [Lo 62] to this class of queueing networks. Bounds based on convex ordering are described in Section 4. Although these arguments yield upper and lower bounds on the moments of customer delays, tighter upper bounds are obtained in Section 5 using stochastic ordering properties of associated RV's. Sections 6 and 7 are devoted to the derivation of bounds of practical interest based on convex ordering and associated RV's respectively. All these bounds exhibit the same stability condition as the initial queueing system.

## 2 Notation and definitions

We are concerned with the delays that customers experience when they traverse an Acyclic Fork-Join Queueing Network  $\beta$ . Here  $\beta$  is represented by an acyclic graph  $G = (V, E)$  where  $V$  is a set of  $B$  FIFO queues labeled  $i = 1, \dots, B$  and  $E$  is a set of links such that  $(i, j) \in E$  implies  $j > i$  (such an ordering is always possible in an acyclic graph).

Define the set of immediate predecessors of queue  $i$ ,  $p(i)$ , to be the set of queues that have a direct link to queue  $i$

$$p(i) = \{ j \in (1, B) \mid (j, i) \in E \} \quad (2.1)$$

and the set of immediate successors of queue  $i$ ,  $s(i)$ , to be the set of queues to which  $i$  has a direct link .

$$s(i) = \{ j \in (1, B) \mid (i, j) \in E \}. \quad (2.2)$$

Define the set of predecessors of queue  $i$ ,  $\pi(i)$ , to be the set of queues that have a (possibly) indirect link to queue  $i$  :

$$\pi(i) = \{i\} \cup p(i) \cup p^2(i) \dots \cup p^{B-1}(i), \quad (2.3)$$

where  $p(X)$  denotes the set of immediate predecessors of the queue of  $X$ , a subset of  $(1, \dots, B)$  and  $p^n(X)$  denotes  $p(p(\dots p(X)\dots))$ .

We also denote as  $s(0)$  the set of queues with no incoming links and as  $p(B+1)$  the set of queues with no outgoing link. It will be assumed that the numbering of queues is such that

$$s(0) = (1, \dots, B_0), \quad B_0 \leq B \quad (2.4)$$

and

$$p(B+1) = (B_1, \dots, B), \quad B_1 \leq B. \quad (2.5)$$

Observe that  $p(i) = \emptyset$  if  $i \in s(0)$  and  $s(i) = \emptyset$  if  $i \in p(B+1)$ .

We associate with queue  $j$ ,  $1 \leq j \leq B$ , a sequence  $\{\sigma_n^j\}_0^\infty$ , where  $\sigma_n^j \in R^+$  represents the service requirement of the  $n$ -th customer to enter this queue. Queue  $j$  behaves as a single server FIFO queue so that an arrival pattern  $\{a_n^j\}_0^\infty$  to this queue together with the sequence  $\{\sigma_n^j\}_0^\infty$  fully determine the sequence of service completion dates ( using the Lindley-Loynes equations ).

### Definition 0

*An acyclic queuing network, as defined above, is an it Acyclic Fork-Join Queuing Network if it obeys the following rules:*

- (i) *There is a single exogeneous arrival stream with pattern  $a_0 = 0 < a_1 < \dots < a_n < \dots \in R^+$ . The  $n$ -th customer arrival to queue  $i$ ,  $1 \leq i \leq B_0$ , coincides with the  $n$ -th date of this exogeneous stream. As stated above, this fully determines the sequence of service completion in the queues  $1 \leq j \leq B_0$ .*
- (ii) *A service completion in queue  $i$  does not systematically trigger an arrival to a queue of  $s(i)$ . The arrivals to queue  $j$ ,  $j > B_0$ , are precisely generated as follows: assume the sequence of service completions is known for all queues  $1 \leq i \leq j$ , where  $B_0 < j \leq B$ . The  $n$ -th customer arrival to queue  $j$ ,  $a_n^j$ , coincides with the latest of the  $n$ -th service completions in the queues of  $p(j)$ . Due to the acyclic structure of  $V$ , this successively defines the arrival patterns in queue  $B_0 + 1, B_0 + 2, \dots, B$ .*
- (iii) *There is a single output stream out of this network. Its  $n$ -th event coincides with the latest of the  $n$ -th service completions in the queues  $B_1, B_1 + 1, \dots, B$ .*

As it will be seen in the next section, these three rules fully determine the evolution of the queuing network.

Some of the bounds discussed in the application sections 6 and 7 will only apply to certain subclasses of AFJQN's, namely parallel and series networks. An AFJQN  $\beta$  is said to be a parallel one with  $K \geq 2$  subnetworks with respective underlying graphs  $G_k = (V_k, E_k)$ ,  $1 \leq k \leq K$ , if its graph  $G$  is decomposable into the  $K$  disconnected subgraphs  $G_1, \dots, G_K$ . An AFJQN  $\beta$  is said to be a series one with  $K \geq 2$  subnetworks with respective underlying graphs  $G_k = (V_k, E_k)$ ,  $1 \leq k \leq K$ , if its graph  $G$  is connected and exhibits the following property: There are  $K - 1$  vertices  $1 < i_1 < i_2 < \dots < i_{K-1} < B$  such that there are no direct links between the vertices of  $(1, \dots, i_{k-1})$  and those of  $(i_k + 1, \dots, B)$  for all  $1 \leq k \leq K - 1$ . The graph  $G_k$  is defined as the restriction of  $G$  to the vertices  $(i_{k-1} + 1, \dots, i_k)$ , where  $i_0 = 0$  and  $i_K = B$ . Figure 2 illustrates a parallel AFJQN and a series AFJQN.

### 3 Evolution equations and steady state

For  $n \geq 0$  and  $1 \leq i \leq B$ , let  $\sigma_n^i \in R^+$  be the service requirement of the  $n$ -th customer to be served in queue  $i$  ( there is hence a zero-th customer ! ) and  $\tau_n$  be the  $n$ -th interarrival of the exogeneous stream :  $\tau_n = a_{n+1} - a_n$ ,  $n \geq 0$ . Similarly, let  $d_n^i \in R^+$  be the delay between the

$n$ -th exogeneous arrival date and the beginning of the  $n$ -th service in queue  $i$  and  $R_n$  be the  $n$ -th network response time defined as the delay between the  $n$ -th exogeneous arrival and the  $n$ -th date of the global departure process.

**Lemma 1**

Assume the network is empty at time 0. Then, for  $n \geq 0$ ,

$$d_{n+1}^j = \max(\max_{i \in p(j)} (d_{n+1}^i + \sigma_{n+1}^i), d_n^j + \sigma_n^j - \tau_n), \quad (3.1)$$

where the maximum over an empty set is zero by convention and

$$d_0^j = \max_{i \in p(j)} (d_0^i + \sigma_0^i). \quad (3.2)$$

The  $n$ -th network response time,  $R_n$ , is given by

$$R_n = \max_{i \in p(B+1)} (d_n^i + \sigma_n^i). \quad (3.3)$$

**Proof**

The boundary condition (3.2) follows from the assumption on the initial condition and from rules (i) and (ii) that define AFJQN's. For  $j$  such that  $1 \leq j \leq B_0$ , the inputs in queue  $j$  coincide with the exogeneous arrivals and  $d_n^j$  is thus the  $n$ -th waiting time in a FIFO queues with interarrival sequence  $\{\tau_n\}_0^\infty$  and service requirements  $\{\sigma_n^j\}_0^\infty$ . We have hence the classical Lindley-Loynes equations

$$d_{n+1}^j = \max(0, d_n^j + \sigma_n^j - \tau_n), \quad n \geq 0, \quad 1 \leq j \leq B_0, \quad (3.4)$$

which is exactly equation (3.1) since  $p(j) = \emptyset$ .

Let  $j$  be such that  $p(j) \neq \emptyset$ , and assume that  $\{d_n^i\}_0^\infty$  is known for all  $i \in p(j)$  so that the  $n$ -th service completion in queue  $i \in p(j)$  takes place at  $d_n^i + \sigma_n^i$ . According to rule (ii), the  $n+1$ -st arrival to queue  $j$  takes place at

$$a_{n+1} + \max_{i \in p(j)} (d_{n+1}^i + \sigma_{n+1}^i). \quad (3.5)$$

Since the server of queue  $j$  becomes available for serving the  $n+1$ -st customer at time

$$a_n + d_n^j + \sigma_n^j, \quad (3.6)$$

it follows that  $d_{n+1}^j$  is equal to the expression in the r.h.s of equation (3.1). Equations (3.1) and (3.2) are the basic evolution equations of the network, from which the transient bounds of section 4 and 5 will be derived.

The remainder of this section is devoted to the construction of the stationary regime of such networks. This construction will be essential in the continuation of the transient bounds to steady state bounds. Consider the following set of assumptions.

$H_0$  The sequence  $\{\tau_n, \sigma_n^j, 1 \leq j \leq B_0\}_0^\infty$ . on  $(R^+)^{B+1}$  forms a stationary and ergodic sequence of integrable RV's on the probability space  $(\Omega, F, P)$ .



## Theorem 2

Let  $j$  be fixed  $1 \leq j \leq B$ . Assume  $H_0$  holds and that for all  $i \in \pi(j)$ ,  $d_n^i$  converges weakly to a finite and integrable RV  $d_\infty^i$  when  $n$  goes to  $\infty$ . Assume in addition that

$$E[\sigma_n^i] < E[\tau_n] \quad \forall i \in \pi(j). \quad (3.7)$$

Then the distribution functions of the RV's  $d_n^j$  converge weakly to a finite RV  $d_\infty^j$  when  $n$  goes to  $\infty$ . More precisely, under these conditions, there exists a sequence of RV's  $\delta_n^j$ ,  $n \geq 0$  on  $(\Omega, F, P)$  such that  $\delta_n^j$  and  $d_n^j$  are equivalent in law for all  $n \geq 0$  ( $d_n^j =_{st} \delta_n^j$ ) and  $\delta_n^j$  increases pathwise to a finite limit  $\delta_\infty^j$  when  $n$  goes to  $\infty$ .

The proof is presented in Appendix 1.

## 4 Bounds based on convex ordering

We are now in position to prove the stochastic ordering result. Consider a network  $\beta$  in  $C$  and assume that all the RV's  $\{a_n\}_0^\infty$  and  $\{\sigma_n^j\}_0^\infty$ ,  $1 \leq j \leq B$  are defined on the probability space  $(\Omega, F, P)$  and are all integrable.

Let now  $\{\tilde{a}_n\}_0^\infty$  and  $\{\tilde{\sigma}_n^j\}_0^\infty$ ,  $1 \leq j \leq B$ , be a set of "smoother" arrival and service processes on  $(\Omega, F, P)$  in the sense that there exists a sub  $\sigma$ -algebra say  $G$  of  $F$  such that for all  $n \geq 0$ ,

$$\tilde{\tau}_n = \tilde{a}_{n+1} - \tilde{a}_n = E[\tau_n | G] \quad a.s. \quad (4.1)$$

and for all  $j$  in  $B$ ,

$$\tilde{\sigma}_n^j = E[\sigma_n^j | G] \quad a.s. \quad (4.2)$$

These new variables are smoother than the original ones in the following sense : let  $\tilde{b}$  and  $b$  be two non-negative and integrable RV's on  $(\Omega, F, P)$  such that

$$\tilde{b} = E[b | G] \quad a.s. \quad (4.3)$$

Owing to Jensen's theorem for conditional expectations, (4.3) entails

$$f(\tilde{b}) = f(E[b | G]) \leq E[f(b | G)], \quad a.s. \quad (4.4)$$

for all convex nondecreasing function  $f: R^+ \rightarrow R^+$  such that the expectations exist. This in turn entails that for all such  $f$

$$E[f(\tilde{b})] \leq E[f(b)] \quad (4.5)$$

which can be rephrased in terms of the convex increasing stochastic ordering of Stoyan [St 84] as follows :

$$\tilde{b} \leq_{ci} b. \quad (4.6)$$

Observe that  $b$  and  $\tilde{b}$  have hence the same first moment and higher moments are always larger for  $b$  than for  $\tilde{b}$ .

Let  $\tilde{d}_n^j$  be the delay variable obtained with the new arrival and service pattern  $\{\tilde{\tau}_n\}_0^\infty, \{\tilde{\sigma}_n^j\}_0^\infty$ ,  $j = 1, B$ . The main result of this section is the following theorem :

**Theorem 3**

For all  $n \geq 0$  and  $1 \leq j \leq B$ ,

$$d_n^j \text{ is integrable and } \tilde{d}_n^j \leq E[d_n^j|G] \text{ a.s.} \quad (4.7)$$

**Proof**

**Basis step**

Consider the case  $n = 0$  we shall show that (4.7) holds for all  $j = 1, B$  by induction on  $j$ .

**Basis step**

Consider all  $j$  such that  $p(j) = \emptyset$ , equation (3.2) shows that

$$d_0^j = \tilde{d}_0^j = 0, \quad (4.8)$$

so that (4.7) holds.

**Inductive step**

Assume that the hypothesis is true for all  $i, 1 \leq i < j$  where  $B_0 \leq j \leq B$ . It is plain from (3.2) that  $d_0^j$  is then integrable. Applying Jensen's inequality for conditional expectations to (3.2) yields

$$E[d_0^j|G] \geq \max_{i \in p(j)} (E[d_0^i|G] + \tilde{\sigma}_0^i), \quad (4.9)$$

so that if the predecessors of  $j$  satisfy property (4.7), so does queue  $j$  since (4.9) implies then :

$$E[d_0^j|G] \geq \max_{i \in p(j)} (\tilde{d}_0^i + \tilde{\sigma}_0^i). \quad (4.10)$$

This completes the proof of the basis step.

**Inductive step** Assume now that the property (4.7) was established for all queues up to rank  $n$ . We now show that the property holds also for  $n + 1$ . This is done by induction on  $1 \leq j \leq B$ .

**Basis step**

Consider all  $j$  such that  $p(j) = \emptyset$ . (3.1)

$$d_{n+1}^j = \max(d_n^j + \sigma_n^j - \tau_n, 0), \quad (4.11)$$

so that  $d_{n+1}^j$  is also integrable. Jensen's inequality together with (4.1) and (4.2) imply that

$$E[d_{n+1}^j|G] \geq \max(E[d_n^j|G] + \tilde{\sigma}_n^j - \tilde{\tau}_n, 0) \quad (4.12).$$

Hence, since (4.7) is satisfied for rank  $n$ , we get from (4.12) that

$$E[d_{n+1}^j|G] \geq \max(\tilde{d}_n^j + \tilde{\sigma}_n^j - \tilde{\tau}_n, 0) = \tilde{d}_{n+1}^j \text{ a.s., } 1 \leq j \leq B_0, \quad (4.13)$$

so that the property is also true for rank  $n + 1$ .

**Inductive step**

Assume (4.7) holds for all  $i, 1 \leq i < j$ , where  $B_0 < j \leq B$  we now show that the property holds for  $j$ . It follows from (3.1) that  $d_{n+1}^j$  is also integrable. Applying Jensen's inequality to (3.1) and using (4.1) and (4.2), we get

$$E[d_{n+1}^j | G] \geq \max(\max_{i \in p(j)} (E[d_{n+1}^i | G] + \tilde{\sigma}_{n+1}^i), E[d_n^j | G] + \tilde{\sigma}_n^j - \tilde{r}_n). \quad (4.14)$$

Using now the ordering property for rank  $n$ , we get

$$E[d_{n+1}^j | G] \geq \max(\max_{i \in p(j)} (E[d_{n+1}^i | G] + \tilde{\sigma}_{n+1}^i), \tilde{d}_n^j + \tilde{\sigma}_n^j - \tilde{r}_n) \text{ a.s.} \quad (4.15)$$

Since the property is satisfied for the predecessors of  $j$ , we get that it is then satisfied by queue  $j$  too since (4.15) entails that

$$E[d_{n+1}^j | G] \geq \max(\max_{i \in p(j)} (\tilde{d}_{n+1}^i + \tilde{\sigma}_{n+1}^i), \tilde{d}_n^j + \tilde{\sigma}_n^j - \tilde{r}_n) = \tilde{d}_{n+1}^j \text{ a.s.} \quad (4.16)$$

This complete the induction step on  $j$ .

This completes the induction step on  $n$  and proves the lemma.

**Remark**

Observe that theorem 3 also holds under the weaker assumptions.

$$\tilde{r}_n \geq E[r_n | G], \quad n \geq 0 \quad (4.17)$$

and

$$\tilde{\sigma}_n^j \leq E[\sigma_n^j | G], \quad n \geq 0, \quad j = 1, B. \quad (4.18)$$

**Corollary 4**

For all  $n \geq 0$  and  $i = 1, B$ .

$$d_n^i \geq_{ci} \tilde{d}_n^i. \quad (4.19)$$

**Proof**

Due to Jensen's inequality

$$E[f(d_n^j) | G] \geq f(E[d_n^j | G]), \quad (4.20)$$

so that using equation (4.7) and the increasingness of  $f$ ,

$$E[f(d_n^j) | G] \geq f(\tilde{d}_n^j). \quad (4.21)$$

Equation (4.19) follows now directly from (4.21).

The next corollary shows that if the network achieves steady state in the sense of Theorem 2, the transient bounds of corollary 4 extend to steady state.

### Corollary 5

Assume that both  $\{\tau_n, \sigma_n^j, j = 1, B\}_0^\infty$  and  $\{\tilde{\tau}_n, \tilde{\sigma}_n^j, j = 1, B\}_0^\infty$  satisfy the condition  $H_0$  and that  $d_n^j$  and  $\tilde{d}_n^j$  converge weakly to finite RV's  $d_\infty^j$  and  $\tilde{d}_\infty^j$  respectively. Then

$$\tilde{d}_\infty^j \leq_{ci} d_\infty^j. \quad (4.22)$$

### Proof

Assume  $f(\delta_\infty^j)$  is integrable. Since  $\delta_n^j \leq \delta_\infty^j$ , and  $d_n^j =_{st} \delta_n^j$ ,  $\tilde{d}_n^j =_{st} \tilde{\sigma}_n^j$ , it is then easy to prove that  $f(d_n^j)$  and  $f(\tilde{d}_n^j)$  are both integrable for all  $n \geq 0$  so that corollary 4 entails

$$E[f(\delta_n^j)] = E[f(d_n^j)] \leq E[f(\tilde{d}_n^j)] = E[f(\tilde{\sigma}_n^j)]. \quad (4.23)$$

Letting  $n$  go to infinity in the inequality

$$E[f(\delta_n^j)] \leq E[f(\tilde{\sigma}_n^j)] \quad (4.24)$$

yields the desired result using the bounded convergence theorem.

### Remark 1

Consider a two queue series network and denote as  $W_n^j$ ,  $n \geq 0$ ,  $j = 1, 2$  the waiting time of the  $n$ -th customer to enter queue  $j$ . We have the following inductions for the RV's  $W_n^i$  initialized by the condition  $W_0^i = 0$  :

$$W_{n+1}^1 = \max(W_n^1 + \sigma_n^1 + a_n - a_{n+1}, 0), \quad n \geq 0 \quad (4.25)$$

and

$$W_{n+1}^2 = \max(W_n^2 + \sigma_n^2 + d_n - d_{n+1}, 0), \quad n \geq 0, \quad (4.26)$$

where the RV's  $\{d_n\}_0^\infty$  are the departure epochs from queue 1 :

$$d_{n+1} - d_n = \sigma_{n+1}^1 + \max(a_{n+1} - a_n - \sigma_n^1 - W_n^1, 0). \quad (4.27)$$

Observe that due to the decreasingness of the r.h.s of (4.27), considered as a function of  $W_n^1$ , we cannot derive from this any simple comparison result between  $(d_{n+1} - d_n)$  and  $(\tilde{d}_{n+1} - \tilde{d}_n)$  when using Jensen's inequality as before.

We prove in Appendix 2 that there is actually no such general ordering result by considering two simple stationary queueing systems where an increased variability of the sequence  $(\tau_n, \sigma_n^1)$  has the following respective effects :

- It increases the variability of the interdeparture distribution for the first one,
- It decreases it for the second one.

This strongly suggests that the stochastic ordering result of this section, which apply to the total delays  $d_n^j$ , does not extend to the individual waiting times  $W_n^j$ .

## 5 Bounds based on association

## 5.1 Association of the delays

Before entering the core of this section, we introduce some terminology that will be useful in the forthcoming analysis and review the properties of stochastic ordering and associated RV's that will be useful to us.

### Definition 6 ([BP 75])

Real valued RV's  $a_1, \dots, a_n$  are said to be associated if

$$\text{cov}[h(a_1, \dots, a_n), g(a_1, \dots, a_n)] \geq 0 \quad (5.1.1)$$

for all pairs of increasing functions  $h, g : R^n \rightarrow R$ . Association of RV's entails the following properties :

1. Any subset of associated RV's are associated,
2. Increasing functions of associated RV's are associated,
3. Independent RV's are associated,
4. If two sets of associated RV's are independent of one another, then their union forms a set of associated RV's ,
5. If  $a_1, \dots, a_n$  are associated RV's, then

$$P[\max_{1 \leq i \leq n} a_i \leq t] \geq \prod_{i=1}^n P[a_i \leq t]. \quad (5.1.2)$$

We are now in position to derive the main results. Network  $\beta$ ,  $\{\tau_n\}_0^\infty$  and  $\{\sigma_n^j\}_0^\infty$ ,  $j = 1, B$  are defined as in section 2. The following assumptions will be made throughout the section

$$\begin{aligned} H_1 \quad & \{\tau_n\}_0^\infty \text{ is independent of } \{\{\sigma_n^j\}_0^\infty\}, 1 \leq j \leq B, \\ & \{\tau_n\}_0^\infty \text{ is a set of independent RV's and} \\ & \{\{\sigma_n^j, 1 \leq j \leq B\}_0^\infty\}, \text{ is a set of independent RV's.} \end{aligned}$$

### Lemma 7

Assume  $H_1$  holds. For all  $m \geq 0$ ,  $\{d_n^j, 1 \leq j \leq B, 0 \leq n \leq m\}$  is a set of associated RV's .

### Proof

We shall actually prove the more general result that  $\{d_n^j, 1 \leq j \leq B, 0 \leq n \leq m-1\} \cup \{-\tau_n, n \leq 0\} \cup \{\sigma_n^j, n \geq 0, 1 \leq j \leq B\}$  is a set of associated RV's for  $1 \leq k \leq B$ ,  $m > 0$ . This is done by induction on  $m$ .

### Basis step

Consider the case  $m = 1$ . We shall show that  $\{d_0^j, 1 \leq j \leq k\} \cup \{-\tau_n, n \geq 0\} \cup \{\sigma_n^j, n \geq 0, 1 \leq j \leq B\}$  is a set of associated RV's for all  $1 \leq k \leq B$  by induction on  $k$ .

### Basis step

Consider all  $j$  such that  $p(j) = \emptyset$ .  $d_0^j$  can be expressed as

$$d_0^j = 0. \quad (5.1.3)$$

Consequently,  $\{d_0^j\}, 1 \leq j \leq B_0$  is a set of independent RV's which along with  $\{-\tau_n, n \geq 0\} \cup \{\sigma_n^j, n \geq 0, 1 \leq j \leq B\}$  form a set of associated RV's according to property 4.

### Inductive step

Assume that the hypothesis is true for all  $i$ ,  $1 \leq i < k$  where  $B_0 \leq k \leq B$ . We now show that it is also true for  $k$ . Note that  $p(k) \neq \emptyset$ . By definition,

$$d_0^k = \max_{i \in p(k)} (d_0^i + \sigma_0^i) \quad (5.1.4)$$

which is an increasing function of associated RV's (note that  $i < k$  if  $i \in p(k)$ ). Therefore it follows that  $\{d_0^j, 1 \leq j \leq k\} \cup \{-\tau_n, n \geq 0\} \cup \{\sigma_n^j, n \geq 0, 1 \leq j \leq B\}$  is a set of associated RV's .

This completes the proof of the basis step.

### Inductive step

Assume that the hypothesis is true up to  $m$ . We now show that the hypothesis holds also for  $m+1$ . This is done by showing that the RV's  $\{d_n^j, 1 \leq j \leq k, 0 \leq n \leq m\} \cup \{-\tau_n, n \geq 0\} \cup \{\sigma_n^j, n \geq 0, 1 \leq j \leq B\}$  are associated for all  $1 \leq k \leq B$  by induction on  $k$ .

#### Basis step

We first show that  $\{d_n^j, 0 \leq n \leq m, 1 \leq j \leq B\} \cup \{-\tau_n, n \geq 0\} \cup \{\sigma_n^j, n \geq 0, 1 \leq j \leq B\} \cup \{d_{m+1}^j, 1 \leq j \leq B_0\}$  is a set of associated RV's . By hypothesis we already know that  $\{d_n^j, 1 \leq n \leq m, 1 \leq j \leq B\} \cup \{-\tau_n, n \geq 0\} \cup \{\sigma_n^j, n \geq 0, 1 \leq j \leq B\}$  is a set of associated RV's . Now, for  $1 \leq j \leq B_0$ ,

$$d_{m+1}^j = \max(d_m^j + \sigma_m^j - \tau_m, 0) \quad (5.1.5)$$

is an increasing function of associated RV's which proves the result.

#### Inductive step

Assume  $\{d_n^j, 1 \leq n \leq m, 1 \leq j \leq B\} \cup \{-\tau_n, n \geq 0\} \cup \{\sigma_n^j, n \geq 0, 1 \leq j \leq B\} \cup \{d_{m+1}^j, 1 \leq j \leq k\}$  is a set of associated RV's for  $B_0 \leq i < k$  where  $B_0 \leq k \leq B$ . We now show that the hypothesis holds for  $k$ . The expression for  $d_{m+1}^k$  is

$$d_{m+1}^k = \max(\max_{i \in p(k)} (d_{m+1}^i + \sigma_{m+1}^i), d_m^k + \sigma_m^k - \tau_m) \quad (5.1.6)$$

which is an increasing function of associated RV's , hence the result.

This complete the induction step on  $k$  and the hypothesis is true for  $k = B$ .

This completes the induction step on  $m$  and proves the lemma.

### Remark

Lemma 7 holds under the weaker assumptions

$$\begin{aligned} H'_1 \quad & \{\tau_n\}_0^\infty \text{ is independent of } \{\{\sigma_n^j\}_0^\infty\}, 1 \leq j \leq B, \\ & \{\tau_n\}_0^\infty \text{ is a set of associated RV's and} \\ & \{\{\sigma_n^j, 1 \leq j \leq B\}_0^\infty\}, \text{ is a set of associated RV's.} \end{aligned}$$

## 5.2 Bounds based on stochastic ordering

This section will mainly deal with distribution functions rather than with RV's .

### Definition 8

Let  $F$  and  $G$  be two distributions functions on  $R$ .  $F$  is said to stochastically dominate  $G$ ,  $F \geq_{st} G$ , iff

$$F(x) \leq G(x), \forall x \in R. \quad (5.2.1)$$

If  $a$  and  $b$  are two real valued RV's, we shall say that  $a \geq_{st} b$  whenever

$$P[a \leq x] \leq P[b \leq x], \forall x \in R. \quad (5.2.2)$$

A consequence of the above definition and property 5 of associated RV's is

**Lemma 9**

Let  $(a_1, \dots, a_n)$  be a set of associated real valued RV's with respective distribution function  $F_1, \dots, F_n$ . Let  $F$  be the distribution function of  $\max(a_1, \dots, a_n)$ . Then

$$F \leq_{st} \prod_{i=1}^n F_i. \quad (5.2.3)$$

Last, we state the following obvious lemma.

**Lemma 10**

Let  $(F_1, \dots, F_n)$  and  $(G_1, \dots, G_n)$  be two families of distribution functions on  $R$ . If  $F_i \geq_{st} G_i = 1, n$ , then

$$F_1 \cdot F_2 \dots F_n = \prod_{i=1}^n F_i \geq_{st} \prod_{i=1}^n G_i = G_1 \cdot G_2 \dots G_n \quad (5.2.4)$$

and

$$F_1 * F_2 * \dots * F_n \geq_{st} G_1 * G_2 * \dots * G_n, \quad (5.2.5)$$

where  $\cdot$  and  $*$  respectively denote the product and the convolution of distribution functions.

In the sequel, network  $\beta$  is given as in the preceding sections. We denote as  $\Sigma_n^j$  ( resp.  $T_n^-$  ) the distribution functions on  $R$  of the RV  $\sigma_n^j$  ( resp.  $\tau_n$  ). Notice that  $\Sigma_n^j$  has its support on  $R^+$  and  $T_n^-$  on  $R^-$ .

We define a sequence  $D_n^j$ ,  $n \geq 0$ ,  $1 \leq j \leq B$  of distribution function on  $R$  by the following recursion

$$\hat{D}_0^j = \prod_{i \in p(j)} (\hat{D}_0^i * \Sigma_0^i), \quad j = 1, B \quad (5.2.6)$$

and

$$\hat{D}_{n+1}^j = \left( \prod_{i \in p(j)} \hat{D}_{n+1}^i * \Sigma_{n+1}^i \right) \cdot (\hat{D}_n^j * \Sigma_n^j * T_n^-). \quad (5.2.7)$$

In these definitions, the product over an empty set is always understood as the step distribution function  $U$  defined by

$$U(t) = 0, \quad t < 0, \quad U(t) = 1, \quad t \geq 0 \quad (5.2.8).$$

It can be checked by induction that the RV's  $\hat{D}_n^j$  have their support on  $R^+$ .

**Theorem 11**

Assume  $H_1$  is satisfied. Let  $D_n^j$  be the distribution function of the RV's  $d_n^j$ ,  $n \geq 0$ ,  $1 \leq j \leq B$ . We have then

$$D_n^j \leq_{st} \hat{D}_n^j, \quad n \geq 0, \quad j = 1, B. \quad (5.2.9)$$

**Proof**

The proof is by induction on  $n$ . Here  $df(a)$  denotes the distribution function of the RV  $a$ .

**Basis step  $n = 0$ .** This step is shown by induction on  $j$ .

**Basis step**

Consider queue  $j$  where  $p(j) = \emptyset$ .  $\hat{D}_0^j = D_0^j = U$ , so that the result holds true.

**Inductive step**

Assume the theorem is true for  $B_0 \leq j \leq B$ . We now show that it is true for  $j + 1$ . Note that  $p(j) \neq \emptyset$ . We have

$$\hat{D}_0^{j+1} = \prod_{i \in p(j+1)} (\hat{D}_0^i * \Sigma_0^i) \geq_{st} \prod_{i \in p(j+1)} (D_0^i * \Sigma_0^i) \quad (5.2.10)$$

(by induction hypothesis and lemma 10)

$$\geq_{st} df\left(\max_{i \in p(j+1)} d_0^i + \sigma_0^i\right)$$

(by lemma 7 and lemma 9 plus assumption  $H_1$  which entails that  $d_0^i$  and  $\sigma_0^i$  are independent RV's).

$$= D_0^{j+1}$$

(by definition).

This proves the basis step for  $n$ .

**Inductive step**

Assume that the theorem is true for  $n$ . We now show that it is true for  $n + 1$  by induction on  $j$ .

**Basis step**

We first do it for  $j \in V$  such that  $p(j) = \emptyset$ :

$$\hat{D}_{n+1}^j = U.(\hat{D}_n^j * \Sigma_n^j * T_n^-) \geq_{st} U.(D_n^j * \Sigma_n^j * T_n^-) \quad (5.2.11)$$

(induction assumption)

$$= df(\max(d_n^j + \sigma_n^j - \tau_n, 0))$$

(by assumption  $H_1$  which entails that  $d_n^j$  is independent of  $\sigma_n^j - \tau_n$ )

$$= D_{n+1}^j.$$



This completes the basis step.

### Induction step

We now assume the theorem is true for  $B_0 \leq j \leq B$  and prove it for  $j + 1$ . We have

$$\begin{aligned} \hat{D}_{n+1}^{j+1} &= \left( \prod_{i \in p(j+1)} (\hat{D}_{n+1}^i * \Sigma_{n+1}^i) \right) \cdot (\hat{D}_n^{j+1} * \Sigma_n^{j+1} * T_n^-) \\ &\geq_{st} \left( \prod_{i \in p(j+1)} (D_{n+1}^i * \Sigma_{n+1}^i) \right) \cdot (D_n^{j+1} * \Sigma_n^{j+1} * T_n^-). \end{aligned} \quad (5.2.12)$$

(inductive hypothesis and lemma 10).

$$\geq_{st} df(\max(\max_{i \in p(j+1)} (d_{n+1}^i + \sigma_{n+1}^i), d_n^{j+1} + \sigma_n^{j+1} - \tau_n))$$

(where we used that  $d_{n+1}^i$  is independent of  $\sigma_{n+1}^i$  and  $d_n^{j+1}$  of  $\sigma_n^{j+1} - \tau_n$  due to  $H_1$ , then that  $(d_{n+1}^i + \sigma_{n+1}^i)$  and  $(d_n^{j+1} + \sigma_n^{j+1} - \tau_n)$  form a set of associated RV's due to lemma 7 and finally lemma 9)

$$= D_{n+1}^{j+1}$$

(by definition).

This concludes the proof of the inductive step, and the proof of the theorem.

The next result concerns the extension of the transient bounds of theorem 12 to steady state.  $H_2$  will denote the following set of assumptions :

$H_2$  Assumption  $H_1$ ,

The sequence  $\{\tau_n\}_0^\infty$  is i.i.d. with  $\tau_n$  integrable,

The sequence  $\{\sigma_n^j\}_0^\infty$  is i.i.d. with  $\sigma_n^j$  integrable for all  $j = 1, B$ .

### Theorem 12

Let  $j$  be fixed  $1 \leq j \leq B$ . Assume  $H_2$  holds and that for all  $i \in p(j)$ ,  $\hat{D}_n^i$  converges weakly to a finite and integrable distribution function  $\hat{D}_\infty^i$  when  $n$  goes to  $\infty$ . Assume in addition that

$$E[\sigma_n^j] < E[\tau]. \quad (5.2.13)$$

Then the distribution functions  $\hat{D}_n^j$  converge weakly to a finite distribution function  $\hat{D}_\infty^j$  when  $n$  goes to  $\infty$ . Denote as  $D_n^j$  the distribution function of  $d_n^j$ . Under the foregoing assumptions, the distribution functions  $D_n^j$  converge weakly to a finite distribution function  $D_\infty^j$  when  $n$  goes to  $\infty$  and  $\hat{D}_\infty^j$  stochastically dominates  $D_\infty^j$ , namely

$$D_\infty^j \leq_{st} \hat{D}_\infty^j. \quad (5.2.13)$$

The proof is found in Appendix 3.

## 6 Applications of bounds based on convex ordering

The following set of assumptions will be assumed to hold throughout the section:

$H_3$ . The  $j + 1$  sequences  $\{\tau_n\}_0^\infty, \{\sigma_n^j\}_0^\infty, j = 1, \dots, B$  are mutually independent.

### 6.1 Determinism minimizes response times

The property that under certain independence assumptions, deterministic interarrival times ( resp. service times ) minimize response times in G/G/1 queues, as shown in [St 84] and [Wh 84], can be extended to AFJQN's using Theorem 3.

Let  $\{\tilde{d}_n^j\}_0^\infty$  ( resp.  $\{\bar{d}_n^j\}_0^\infty$  ),  $j = 1, \dots, B$  be the response times obtained for the constituting sequences  $\{\tilde{\tau}_n\}_0^\infty$  and  $\{\tilde{\sigma}_n^j\}_0^\infty, j = 1, \dots, B$  ( resp.  $\{\bar{\tau}_n\}_0^\infty$  and  $\{\bar{\sigma}_n^j\}_0^\infty, j = 1, \dots, B$  ) respectively defined by the equations:

$$\tilde{\tau}_n = E[\tau_n], \quad n \geq 0 \quad (6.1.1)$$

$$\tilde{\sigma}_n^j = \sigma_n^j, \quad j = 1, \dots, B, \quad n \geq 0 \quad (6.1.2)$$

and

$$\bar{\tau}_n = \tau_n, \quad n \geq 0 \quad (6.1.3)$$

$$\bar{\sigma}_n^j = \sigma_n^j, \quad j = 1, \dots, B, \quad j \neq j_0, \quad n \geq 0 \quad (6.1.4)$$

$$\bar{\sigma}_n^{j_0} = E[\sigma_n^{j_0}], \quad n \geq 0 \quad (6.1.5)$$

where  $j_0$  is any fixed integer  $1 \leq j_0 \leq B$ .

#### Corollary 13

For all  $n \geq 0$  and  $j = 1, \dots, B$ , the following inequalities hold

$$\tilde{d}_n^j \leq_{ci} d_n^j, \quad n \geq 0 \quad (6.1.6)$$

and

$$\bar{d}_n^j \leq_{ci} d_n^j, \quad n \geq 0 \quad (6.1.7)$$

#### Proof

Let  $\tilde{G}$  ( resp.  $\bar{G}$  ) be the sub  $\sigma$ -fields of  $F$  generated by the RV's  $\{\sigma_n^j\}_0^\infty, j = 1, \dots, B$  ( resp.  $\{\tau_n\}_0^\infty$  and  $\{\sigma_n^j\}_0^\infty, j = 1, \dots, B, j \neq j_0$  ). We first get from the independence assumption that

$$\tilde{\tau}_n = E[\tau_n | \tilde{G}], \quad n \geq 0 \quad (6.1.8)$$

$$\bar{\tau}_n = E[\tau_n | \bar{G}], \quad n \geq 0 \quad (6.1.9)$$

and

$$\tilde{\sigma}_n = E[\sigma_n | \tilde{G}], \quad n \geq 0 \quad j = 1, \dots, B, \quad (6.1.10)$$

$$\bar{\sigma}_n = E[\sigma_n | \bar{G}], \quad n \geq 0 \quad j = 1, \dots, B, \quad (6.1.11)$$

so that Theorem 3 entails

$$\tilde{d}_n^j \leq E[d_n^j | \tilde{G}], \quad n \geq 0 \quad j = 1, \dots, B \quad (6.1.12)$$

and

$$\bar{d}_n^j \leq E[d_n^j | \bar{G}], \quad n \geq 0 \quad j = 1, \dots, B. \quad (6.1.13)$$

Equations (6.1.6) and (6.1.7) are mere rephrasing of (6.1.12) and (6.1.13) respectively.

The lower bounds (6.1.12) and (6.1.13) on  $d_n^j$  extend to steady state when the constituting sequences  $\{\tau_n\}_0^\infty$  and  $\{\sigma_n^j\}_0^\infty$ ,  $j = 1, \dots, B$  satisfy the assumptions of Theorem 2. Indeed, these conditions entail that both the constituting sequences  $\{\tilde{\tau}_n\}_0^\infty$ ,  $\{\tilde{\sigma}_n^j\}_0^\infty$ ,  $j = 1, \dots, B$  and  $\{\bar{\tau}_n\}_0^\infty$  and  $\{\bar{\sigma}_n^j\}_0^\infty$ ,  $j = 1, \dots, B$  satisfy the assumptions of Theorem 2. Hence Corollary 5 applies to show that the bounds of Corollary 13 extend to steady state, namely

$$\tilde{d}_\infty^j \leq c_i d_\infty^j, \quad j = 1, \dots, B, \quad (6.1.14)$$

$$\bar{d}_\infty^j \leq c_i d_\infty^j, \quad j = 1, \dots, B. \quad (6.1.15)$$

## 6.2 Networks in random environment

The problem of determining the statistics of isolated queues with time varying interarrival times was considered in the markovian case in [Ma 85]. For the general G/G/1 FIFO queue, bounds are also available when the variations depend upon an independent stationary and ergodic "environment" process. It was shown in [BM 86] that the waiting time statistics in such a queueing system are bounded from below by those of the same queue with the environment process kept to its mean value (see also [Ro 83]). Theorem 3 allows to extend this result to any AFJQN  $\beta$ . As in [BM 86], the environment process is assumed to be a non-negative real-valued stochastic process  $V(t)$ ,  $t \in R$  on  $(\Omega, F, P)$  being ergodic and stationary. Two stationary and ergodic sequences of nonnegative RV's are assumed to be given:  $\{\tau_n\}_0^\infty$  and  $\{\sigma_n^j\}_0^\infty$ ,  $j = 1, \dots, B$ . All these RV's are assumed to be integrable with  $E[V(t)] = 1$  holding in particular. The modulation of the arrival process is obtained by accelerating time proportionally to  $V$ , so that the effective interarrival times in the random environment network are given by the sequence  $\{\hat{\tau}_n\}_0^\infty$  defined by

$$\hat{\tau}_n = \int_{a_n}^{a_{n+1}} V(s) ds, \quad n \geq 0. \quad (6.2.1)$$

Let  $\{\hat{d}_n^j\}_0^\infty$  ( resp.  $\{d_n^j\}_0^\infty$  ) be the response times obtained for the constituting sequences  $\{\hat{\tau}_n\}_0^\infty$  ( resp.  $\{\tau_n\}_0^\infty$  ) and  $\{\sigma_n^j\}_0^\infty$ ,  $j = 1, \dots, B$ .

### Corollary 14

If the stochastic process  $V(t)$ ,  $t \in R$  is independent of  $\{\tau_n\}_0^\infty$  and  $\{\sigma_n^j\}_0^\infty$ ,  $j = 1, \dots, B$ , then the following inequality holds for all  $n \geq 0$  and  $j = 1, \dots, B$

$$\hat{d}_n^j \geq c_i d_n^j. \quad (6.2.2)$$

### Proof

Let  $\hat{G}$  be the sub  $\sigma$ -fields of  $F$  generated by the RV's  $\{\sigma_n^j\}_0^\infty$ ,  $j = 1, \dots, B$  and  $\{\tau_n\}_0^\infty$ . It was shown in [BM 86] that under the enforced assumptions, for all  $n \geq 0$

$$E[\hat{\tau}_n | \hat{G}] = \tau_n. \quad (6.2.3)$$

Equation (6.2.2) is now obtained as a direct consequence of Theorem 3.

Consider a fixed queue  $j$ . Observe that under the foregoing assumptions, if  $\{\tau_n\}_0^\infty$  and  $\{\sigma_n^j\}_0^\infty, j = 1, \dots, B$  satisfy the conditions of Theorem 2 for  $j$ , then,  $\{\tau_n\}_0^\infty$  and  $\{\sigma_n^j\}_0^\infty, j = 1, \dots, B$  also satisfy the conditions of Theorem 2 for  $j$ , so that the bounds of Corollary 14 then extend to steady state, namely

$$d_\infty^j \geq c_i d_\infty^j. \quad (6.2.4)$$

### 6.3 Bounds on parallel networks

Theorem 3 also provides lower and upper bounds for the following problem, a particular case of which was considered in [BM 85]. Let  $\beta$  be any AFJQN made of  $K$  AFJQ subnetworks  $\alpha_1, \dots, \alpha_K$  in parallel with respective underlying graphs  $G_l = (V_l, E_l), 1 \leq l \leq K$ . Denote as  $R_n$  the  $n$ -th network response time:

$$R_n = \max_{i \in p(B+1)} (d_n^i + \sigma_n^j) \quad (6.3.1)$$

for the constituting sequences  $\{\tau_n\}_0^\infty$  and  $\{\sigma_n^j\}_0^\infty, j = 1, \dots, B$ . Let  $R_n^l$  denote the  $n$ -th response time in the subnetwork  $\alpha_l, 1 \leq l \leq K$  for the constituting sequences  $\{\tau_n\}_0^\infty$  and  $\{\sigma_n^j\}_0^\infty, j \in V_l$ .

$$R_n^l = \max_{i \in p_l(B+1)} (d_n^i + \sigma_n^j), \quad (6.3.2)$$

where  $p_l(B+1)$  denotes the queues of  $p(B+1)$  which belong to  $V_l$ . Owing to the parallel structure of  $\beta$ , we have

$$R_n = \max_{1 \leq l \leq K} R_n^l. \quad (6.3.3)$$

Let finally  $\tilde{R}_n^l$  denote the  $n$ -th response time in  $\alpha_l$  for the constituting sequence  $\{\tilde{\tau}_n\}_0^\infty$  and  $\{\tilde{\sigma}_n^j\}_0^\infty, j = 1, \dots, B$ , defined by equations (6.1.1) and (6.1.2).

#### Corollary 15

For all  $n \geq 0$

$$R_n \geq c_i \max_{1 \leq l \leq K} \tilde{R}_n^l. \quad (6.3.4)$$

#### Proof

It was established in the proof of Corollary 13 that

$$\tilde{d}_n^j \leq E[d_n^j | \tilde{G}], \quad n \geq 0 \quad j = 1, \dots, B \quad (6.3.5)$$

This and Jensen's Theorem can be used in (6.3.3) to yield

$$\tilde{R}_n^l \leq E[R_n^l | \tilde{G}], \quad n \geq 0 \quad l = 1, \dots, K. \quad (6.3.6)$$

Using now this last inequality and Jensen's Theorem in (6.3.4), we get

$$E[R_n | \tilde{G}] \geq \max_{1 \leq l \leq K} E[R_n^l | \tilde{G}], \quad n \geq 0. \quad (6.3.7)$$

Combining equations (6.3.6) and (6.3.7), we finally obtain

$$E[R_n|\tilde{G}] \geq \max_{1 \leq l \leq K} \tilde{R}_n^l, \quad n \geq 0, \quad (6.3.8)$$

which implies (6.3.4).

**Remark**

Notice that due to our mutual independence assumption on the sequences  $\{\sigma_n^j\}_0^\infty$ ,  $j = 1, \dots, B$ , the sequences  $\{\tilde{R}_n^l\}_0^\infty$ ,  $l = 1, \dots, K$  are mutually independent as well. In other words, Corollary 14 allows us to derive lower bounds for the network response times that reduce to computing the maximum of  $K$  independent RV's being the response times of subnetworks of smaller size than the initial one.

Upper bounds can also be obtained using convex ordering in the following particular case: assume the arrival process is divisible in the sense that there exist  $K$  mutually independent sequences of RV's  $\{\tau_n^l\}_0^\infty$  which satisfy the mean condition:

$$\tau_n = \frac{\sum_{l=1}^K \tau_n^l}{K}, \quad n \geq 0. \quad (6.3.9)$$

Let  $d_n^j$  (resp.  $\check{R}_n^l$ ) denote the delay between the  $n$ -th arrival and the beginning of the  $n$ -th service in queue  $j$  (resp. the  $n$ -th response time) in  $V_l$  for the constituting sequence  $\{\tau_n^l\}_0^\infty$  and  $\{\sigma_n^j\}_0^\infty$ ,  $j = 1, \dots, B$ ,  $l \in \alpha_l$ .

**Corollary 16**

For all  $n \geq 0$

$$R_n \leq_{ci} \max_{1 \leq l \leq K} \check{R}_n^l. \quad (6.3.10)$$

**Proof**

Let  $\tilde{G}$  be the sub  $\sigma$ -algebra of  $F$  generated by the RV's  $\{\tau_n\}_0^\infty$  and  $\{\sigma_n^j\}_0^\infty$ ,  $j = 1, \dots, B$ . For all  $n \geq 0$ , We get from the exchangeability of the RV's  $\{\tau_n^l\}_0^\infty$  and the independence assumptions that for all  $n \geq 0$ ,

$$E[\tau_n^l] = \tau_n. \quad (6.3.11)$$

Using Jensen's inequality in

$$\check{R}_n = \max_{1 \leq l \leq K} \check{R}_n^l, \quad (6.3.12)$$

we get

$$E[\max_{1 \leq l \leq K} \check{T}_n^l | \tilde{G}] \geq \max_{1 \leq l \leq K} \max_{j \in V_l} (E[d_n^j | \tilde{G}] + \sigma_n^j). \quad (6.3.13)$$

This together with Theorem 3 entail

$$E[\max_{1 \leq l \leq K} \check{T}_n^l | \tilde{G}] \geq \max_{1 \leq l \leq K} \max_{j \in V_l} (d_n^j + \sigma_n^j) = T_n, \quad (6.3.14)$$

which completes the proof of (6.3.10).

Notice that for this upper bound too, the RV's  $\check{T}_n^l$  are mutually independent and can be obtained by considering subnetworks of smaller dimensions than the initial one. Observe that if  $\{\tau_n\}_0^\infty$  and  $\{\sigma_n^j\}_0^\infty$ ,  $j = 1, \dots, B$  ( resp.  $\{\tau_n^l\}_0^\infty$  and  $\{\sigma_n^j\}_0^\infty$ ,  $j = 1, \dots, B$  ) satisfy the conditions of

Theorem 2 for all  $j = 1, \dots, B$ , the bounds of Corollary 15 ( resp. 16 ) then extend to steady state namely,

$$R_\infty \geq_{ci} \max_{1 \leq l \leq K} \tilde{R}_\infty^l. \quad (6.3.15)$$

and

$$R_\infty \leq_{ci} \max_{1 \leq l \leq K} \tilde{R}_\infty^l. \quad (6.3.16)$$

#### 6.4 Bounds on series networks

Let  $\beta$  be any AFJQN made of  $K$  AFJQ subnetworks  $\alpha_1, \dots, \alpha_K$  in series with respective underlying graphs  $G_l = (V_l, E_l)$ ,  $1 \leq l \leq K$ . Owing to the series structure of the network, the subnetworks  $\beta_l^*$ ,  $1 \leq l \leq K$  of  $\beta$  obtained by considering only the queues of  $V_1 \cup \dots \cup V_l$  are also in the AFJQN class. Let  $R_n^l$  denote the  $n$ -th response time in  $\beta_l^*$  for the constituting sequences  $\{\tau_n\}_0^\infty$  and  $\{\sigma_n^j\}_0^\infty$ ,  $j = 1, \dots, B$ ,  $j \in V_1 \cup \dots \cup V_l$ . Let also  $t_n^l$  denote the  $n$ -th interdeparture time of the output stream of  $\beta_l^*$ :

$$t_n^l = R_{n+1}^l - R_n^l, \quad n \geq 0. \quad (6.4.1)$$

Owing to the series structure of  $\beta$ ,  $R_n$  can be decomposed into the sum:

$$R_n = \sum_{l=1}^K \rho_n^l, \quad n \geq 0 \quad (6.4.2)$$

where  $\rho_n^l$  denotes the  $n$ -th response time in the AFJQN  $\alpha_l$ , for the interarrival times sequence  $\{t_{n-1}^l\}_0^\infty$  and the service times sequence  $\{\sigma_n^j\}_0^\infty$ ,  $j$  in  $V_l$  and where  $t_n^0$  stands for  $\tau_n$ ,  $n \geq 0$ .

Similarly, let  $\tilde{\rho}_n^l$  denote the  $n$ -th response time in the AFJQN  $\alpha_l$ , for the constituting sequences  $\{\tilde{t}_{n-1}^l\}_0^\infty$  and  $\{\tilde{\sigma}_n^j\}_0^\infty$ ,  $j$  in  $V_l$ , where

$$\tilde{t}_n^l = E[t_n^l], \quad n \geq 0 \quad (6.4.3)$$

$$\tilde{\sigma}_n^j = \sigma_n^j, \quad j \in V_l, \quad n \geq 0. \quad (6.4.4)$$

#### Corollary 17

For all  $n \geq 0$ , the following inequality holds

$$E[R_n] \geq \sum_{l=1}^K E[\tilde{\rho}_n^l]. \quad (6.4.5)$$

#### Proof

Let  $\tilde{G}_l$  be the sub  $\sigma$ -algebra of  $F$  generated by the RV's  $\{\tau_n\}_0^\infty$  and  $\{\sigma_n^j\}_0^\infty$ ,  $j = 1, \dots, B$ ,  $j$  in  $V_l \cup \dots \cup V_K$ . Owing to the independence assumptions, we have, for all  $n \geq 0$ ,  $1 \leq l \leq K$

$$E[t_n^l | \tilde{G}_l] = E[t_n^l] \quad (6.4.6)$$

and, for all  $j \in V_l$

$$E[\sigma_n^j | \tilde{G}_l] = \sigma_n^j, \quad j \in V_l. \quad (6.4.7)$$

Hence, Theorem 3 applied to the network  $\alpha_l$ , entails that, for all  $n \geq 0$ ,  $1 \leq l \leq K$

$$E[\rho_n^l | \tilde{G}_l] \geq \tilde{\rho}_n^l. \quad (6.4.8)$$

This together with equation (6.4.2) readily entail (6.4.3).

Observe that (6.4.5) obviously holds at steady state provided the first moments involved in this equation converge.

## 7 Applications of bounds based on association

The condition  $H_1$  will be assumed to hold throughout the section so that the assumptions of Lemma 7 and Theorem 12 are satisfied.

### 7.1 Bounds on parallel networks

The notations are those of section 6.3:  $R_n$  ( resp.  $R_n^l$  ) denotes the  $n$ -th response time in  $\beta$  ( resp.  $\alpha_l$ ,  $1 \leq l \leq K$  ) for the constituting sequences  $\{\tau_n\}_0^\infty$  and  $\{\sigma_n^j\}_0^\infty$   $j = 1, \dots, B$ . Under the foregoing assumptions, we have the following strengthening of corollary 16

#### Corollary 18

For all  $n \geq 0$

$$df(R_n) \leq_{st} \prod_{1 \leq l \leq K} df(R_n^l). \quad (7.1.1)$$

#### Proof

It was established in Lemma 7 that the RV's  $\{d_n^j\}_0^\infty$ ,  $j = 1, \dots, B$  are associated. Hence, the RV's  $R_n^l$ ,  $n \geq 0$ ,  $1 \leq l \leq K$ , which are given by (6.3.2) in terms of increasing functions of associated RV's, are also associated, owing to property 2 of associated RV's. Equation (7.1.1) is hence a direct consequence of property 5 (equation (5.1.2)) of association.

Assume the stability condition of Theorem 2 is satisfied. ( Observe that condition  $H_1$  is stronger than condition  $H_0$ . ) Then, the random vectors  $\{d_n^j\}$ ,  $j = 1, \dots, B$  converge weakly to a finite random vector  $\{d_\infty^j\}$ ,  $j = 1, \dots, B$  when  $n$  goes to  $\infty$ . This in turn implies that the random vectors  $\{R_n^l\}$ ,  $l = 1, \dots, K$  ( resp. the RV's  $R_n$  ) converge weakly to a finite random vector ( resp. RV )  $\{R_\infty^l\}$ ,  $l = 1, \dots, K$  ( resp.  $R_\infty$  ) when  $n$  goes to  $\infty$ .

Applying now proposition (1.2.3) of [St 84] to the weakly converging sequences  $df(R_n)$  and  $\prod_{1 \leq l \leq K} df(R_n^l)$  it is plain that equation (7.1.1) extends to steady state, namely

$$df(R_\infty) \leq_{st} \prod_{1 \leq l \leq K} df(R_\infty^l). \quad (7.1.2)$$

The upper bounds of equation (7.1.2) and the lower bounds of equation (6.3.4) are exemplified in Figure 3.

### 7.2 More general bounds. Relation to resequencing

We consider now the case of more general AFJQN's. For these networks, we show that Theorems 11 and 12 can be used to provide computable upper bounds which relate to resequencing models analyzed earlier in [BGP 84]. The discussion of these bounds will be limited to steady

state. It is assumed that each queue satisfies the assumptions of Theorem 12, so that the distribution functions  $D_n^j$  ( resp.  $\hat{D}_n^j$ ),  $j = 1, \dots, B$  converge weakly to a proper distribution function  $D_\infty^j$  ( resp.  $\hat{D}_\infty^j$ ) when  $n$  goes to  $\infty$  and  $D_\infty^j \leq_{st} \hat{D}_\infty^j$  for all  $1 \leq j \leq B$ . Denoting as  $\Sigma^j$  ( resp.  $T^-$ ) the common distribution function of the RV's  $\{\sigma_n^j\}$ ,  $j = 1, \dots, B$ . ( resp.  $-\{\tau_n\}$ ), it follows from equation (5.2.7) that the distribution functions  $\hat{D}_\infty^j$ ,  $j = 1, \dots, B$  satisfy the set of equations (7.2.1)-(7.2.3) below :

$$\hat{D}_\infty^j = U.(\hat{D}_\infty^j * \Sigma^j * T^-), \quad (7.2.1)$$

for  $j$  such that  $p(j) = \emptyset$  and

$$\hat{D}_\infty^j = A^j.(\hat{D}_\infty^j * \Sigma^j * T^-), \quad (7.2.2)$$

for  $j$  such that  $p(j) \neq \emptyset$ , where

$$A^j = \prod_{i \in p(j)} \hat{D}_\infty^i * \Sigma^i. \quad (7.2.3)$$

This set of functional equations can be solved recursively as follows:

First compute the solution  $\hat{D}_\infty^j$  of equation (7.2.1) for all  $1 \leq j \leq B_0$ . This equation is the functional equation satisfied by the distribution function of the stationary waiting times in a GI/GI/1 queue with service times distributed according to  $\Sigma^j$  and (negative) interarrival times according to  $T^-$ .

Next, compute by induction  $\hat{D}_\infty^{B_0+1}, \dots, \hat{D}_\infty^B$  as follows. Assume that the distribution functions  $\hat{D}_\infty^1, \dots, \hat{D}_\infty^{j-1}$  are known for some  $j > B_0$ . Notice first that this and equation (7.2.3) fully determine the distribution function  $A^j$  on  $R^+$ . Hence, the only unknown in equation (7.2.2) is  $\hat{D}_\infty^j$ . This equation is the functional equation satisfied by the distribution function of the stationary end-to-end delays in a GI/GI/GI/1 resequencing queue as considered in [BGP 84] with desordering times distributed according to  $A^j$ , service times distributed according to  $\Sigma^j$  and (negative) interarrival times according to  $T^-$ .

The end of this section is devoted to computational problems related to the solution of these functional equations. General techniques for solving (7.2.1) are well known ( see for instance [Co 85] for a detailed discussion )

We consider now equation (7.2.2), the general form of which is

$$D = A.(D * \Sigma * T^-), \quad (7.2.4)$$

where  $A$ ,  $\Sigma$  and  $T^-$  are known distribution functions on  $R$  with their support on  $R^+$ ,  $R^+$  and  $R^-$  respectively,  $C = \Sigma * T^-$  has a negative mean and  $D$  is the unknown distribution function on  $R_+$ . Closed form solutions have been derived for the solution of (7.2.4) in [BGP 84] for certain classes of distribution functions  $A$  and  $T^-$  namely  $A$  hyperexponential and  $T^-$  exponential. For more general classes of distribution functions, it is established in Appendix 3 that the following numerical schema converges towards the solution of (7.2.1):

$$F_{n+1}^j(t) = A^j(t) \cdot \int_{-\infty}^t F_n^j(t-u) dC^j(u), \quad n \geq 0, \quad t \in R, \quad (7.2.5)$$

where  $C^j = \Sigma^j * T_-$  and



$$F_0^j = A^j. \quad (7.2.6)$$

Here, the functions  $F_n(t)$ ,  $t \in R$  are distribution functions on  $R$  with support on  $R^+$  and the convergence of  $F_n$  towards the solution of (7.2.1) has to be understood in the sense of the weak convergence.

In conclusion, Theorems 11 and 12 provide a general method to compute upper bounds on the stationary delays through AFJQN's with i.i.d. constituting sequences. The computation of these bounds reduces to determining  $B_0$  stationary waiting time distribution functions of GI/GI/1 queues and  $B - B_0$  stationary state end-to-end delays in GI/GI/GI/1 resequencing queues.

## Appendix 1

The basic idea for proving theorem 2 consists in generalizing the schema of Loynes for the response time of a  $G/G/1$  queue ([Lo 62]), to the response times  $d_n^j$  of our network. Let us first consider the sequence  $\{r_n\}_0^\infty$  and  $\{\sigma_n^j\}_0^\infty$  for all  $j \in 1, B$  as the right half of certain bi-infinite sequences  $\{r_n\}_{-\infty}^{+\infty}$  and  $\{\sigma_n^j\}_{-\infty}^{+\infty}$  on  $(\Omega, F, P)$ . We shall assume that  $(\Omega, F, P)$  is the canonical space. Hence  $P$  will be assumed to be  $\theta$ -invariant (stationary) and  $\theta$ -ergodic. Let us denote by  $\tau$  the difference  $a_1 - a_0$ , and by  $\sigma^j$  the variable  $\sigma_0^j$ . Consider now the schema  $\{\delta_n^j\}_0^\infty$  defined by  $\delta_0^j = d_0^j$ , and for  $n \geq 0$  :

$$\delta_{n+1}^j \circ \theta = \max(\max_{i \in p(j)} ((\delta_{n+1}^i + \sigma^i) \circ \theta), \delta_n^j + \sigma^j - \tau). \quad (A.1.1)$$

### Lemma 1

For any  $j \in B$ , the sequence  $\{\delta_n^j\}_{n \geq 0}$  is increasing.

#### Proof

Let us first prove this for  $1 \leq j \leq B_0$ . It is clear that  $\delta_1^j \geq 0 = \delta_0^j$ . Assume now that  $\delta_n^j \geq \delta_{n-1}^j$  for some  $n \geq 1$ . From (A.1.1), we get :

$$\delta_{n+1}^j \circ \theta = \max(0, \delta_n^j + \sigma^j - \tau) \geq \max(0, \delta_{n-1}^j + \sigma^j - \tau) = \delta_n^j \circ \theta, \quad 1 \leq j \leq B_0. \quad (A.1.2)$$

By induction, the  $\delta_n^j, s$  are thus increasing.

Now consider  $j$  such that  $p(j) \neq \emptyset$ . By the induction hypothesis, we can assume that the RV's  $\delta_n^j$  are increasing in  $n$  for  $i \in p(j)$ . We prove first that  $\delta_1^j \geq \delta_0^j$ . We have

$$\delta_1^j \circ \theta = \max(\max_{i \in p(j)} (\delta_1^i + \sigma^i) \circ \theta, \delta_0^j + \sigma^j - \tau) \geq \max_{i \in p(j)} ((\delta_1^i + \sigma^i) \circ \theta) \geq \max_{i \in p(j)} ((\delta_0^i + \sigma^i) \circ \theta), \quad (A.1.3)$$

where we have used our assumption  $\delta_1^i \geq \delta_0^i$ . Notice that the last expression is  $\delta_0^j \circ \theta$  so that the property is proved. Assuming now that  $\delta_n^j \geq \delta_{n-1}^j$ , by (A.1.1) we get

$$\delta_{n+1}^j \circ \theta \geq \max(\max_{i \in p(j)} ((\delta_{n+1}^i + \sigma^i) \circ \theta), \delta_{n-1}^j + \sigma^j - \tau). \quad (A.1.4)$$

Since the  $\delta_n^j$  are increasing for  $i \in p(j)$  we get from the last expression that

$$\delta_{n+1}^j \circ \theta \geq \max(\max_{i \in \pi(j)} ((\delta_{n+1}^i + \sigma^i) \circ \theta), \delta_{n-1}^j + \sigma^j - \tau) = \delta_n^j \circ \theta \quad (\text{A.1.5})$$

and so  $\delta_n^j$  increases in  $n$ .

**Lemma 2**

Let  $\delta_\infty^j$  be the limiting value of the increasing sequence  $\delta_n^j$  when  $n$  goes to infinity. Under the assumptions of theorem 2,  $\delta_\infty^j < \infty$ . If there exists an  $i \in \pi(j)$  such that  $E[\sigma_n^i] > E[\tau_n]$  then  $\delta_\infty^j = \infty$  a.s.

**Proof** The limiting variables  $\delta_\infty^j$  satisfy the pathwise equation :

$$\delta_\infty^j \circ \theta = \max(\max_{i \in \pi(j)} ((\delta_\infty^i + \sigma^i) \circ \theta), \delta_\infty^j + \sigma^j - \tau) \quad (\text{A.1.6})$$

For  $1 \leq j \leq B_0$ , (A.1.6) reduces to

$$\delta_\infty^j \circ \theta = \max(0, \delta_\infty^j + \sigma^j - \tau). \quad (\text{A.1.7})$$

Equation (A.1.7) shows that the event  $\{\delta_\infty^j = \infty\}$  is  $\theta$ -invariant. Therefore, this event is either of probability 0 or 1. Assume that it is of probability 1. By the increasingness property we have

$$E[\max(0, \delta_n^j + \sigma^j - \tau) - \delta_n^j] = E[\delta_{n+1}^j \circ \theta - \delta_n^j] = E[\delta_{n+1}^j - \delta_n^j] \geq 0. \quad (\text{A.1.8})$$

From this we get

$$\lim_{n \rightarrow \infty} E[\max(0, \delta_n^j + \sigma^j - \tau) - \delta_n^j] \geq 0. \quad (\text{A.1.9})$$

Using now Lebesgue's theorem, this inequality is preserved with limit taken inside the expectation. If we assume that  $\delta_n^j \uparrow \infty$ , then we get

$$E[\sigma^j] \geq E[\tau]. \quad (\text{A.1.10})$$

Now taking the contrapositive of this argument, we see that

$$E[\sigma^j] < E[\tau] \quad (\text{A.1.11})$$

is sufficient to have  $\delta_\infty^j$  finite a.e. This completes the proof of the first part of the lemma for  $1 \leq j \leq B_0$ .

Let  $j$  be such that  $B_0 < j \leq B_0$ . Assume now that for all  $i \in \pi(j)$ ,  $\delta_\infty^i$  is a.e. finite and integrable. The proof that condition (A.1.11) entails  $\delta_\infty^j$  finite a.e. proceeds as follows. The event  $\{\delta_\infty^j = \infty\}$  is shown to be  $\theta$ -invariant from (A.1.6). The inequality

$$\limsup_{n \rightarrow \infty} E[(\max(\max_{i \in \pi(j)} ((\delta_{n+1}^i + \sigma^i) \circ \theta), \delta_n^j + \sigma^j - \tau) - \delta_n^j)] \geq 0 \quad (\text{A.1.12})$$

is then established using the increasingness of  $\delta_n^j$  and its integrability as in (A.1.8). One also gets from elementary manipulations that

$$X_n = (\max(\max_{i \in p(j)} ((\delta_{n+1}^i + \sigma^i) \circ \theta), \delta_n^j + \sigma^j - \tau) - \delta_n^j) \leq (\max_{i \in p(j)} ((\delta_{n+1}^i + \sigma^i) \circ \theta) + \sigma^j - \tau). \quad (\text{A.1.13})$$

From the increasingness of  $\delta_n^i$ ,  $i \in p(j)$ , we get hence

$$X_n \leq (\max_{i \in p(j)} ((\delta_\infty^i + \sigma^i) \circ \theta) + \sigma^j - \tau). \quad (\text{A.1.14})$$

Owing to the integrability assumptions, it follows from (A.1.14) that the RV's  $X_n$  are uniformly bounded from above by an integrable RV. The Fatou-Lebesgue lemma and (A.1.12) entail then

$$E[\limsup_n X_n] \geq \limsup_n E[X_n] \geq 0. \quad (\text{A.1.15})$$

Under the assumption  $\delta_\infty^i < \infty$  a.e. for all  $i \in \pi(j)$ , the hypothesis  $\delta_n^j \uparrow \infty$  implies that

$$\limsup_n X_n = \sigma^j - \tau, \quad (\text{A.1.16})$$

so that queue  $j$  satisfies condition (A.1.10). The rest of the proof follows exactly as before.

## Proof of Theorem 2

We get by induction that  $d_n^j = \delta_n^j \circ \theta^n$  (use the fact  $r_n = \tau \circ \theta^n$ ,  $\sigma_n^j = \sigma \circ \theta^n$ ,  $n \geq 0$ ). Hence  $d_n^j$  and  $\delta_n^j$  have the same distribution due to the  $\theta$ -invariance of  $P$ . The weak convergence of the law of  $d_n^j$  to a proper distribution is now a direct consequence of the increasing a.e. of  $\delta_n^j$  to the finite random variable  $\delta_\infty^j$ .

## Appendix 2

*1 - A stationary queueing system where an increased variability of interarrivals decreases the variability of interdeparture times.*

Consider a  $GI/M/1$  queue. The steady state distribution for the number of customers just after a departure is geometrically distributed with parameter  $\sigma$  which is the smallest positive real root of the equation

$$\sigma = A^*(\mu(1 - \sigma)), \quad (\text{A.2.1})$$

where  $A^*$  denotes the Laplace transform of the interarrival times and  $\mu^{-1}$  the mean service time. The interdeparture distribution function has hence the following Laplace transform

$$D^*(s) = (1 - \sigma) \sum_{k \geq 1} \sigma^k \frac{\mu}{\mu + s} + (1 - \sigma) A^*(s) \frac{\mu}{\mu + s} \quad (\text{A.2.2})$$

$$= (1 - \sigma) A^*(s) \frac{\mu}{\mu + s} + \sigma \frac{\mu}{\mu + s}. \quad (\text{A.2.3})$$

The mean interdeparture time is hence

$$d = \frac{1}{\mu} + (1 - \sigma) \frac{1}{\lambda}, \quad (\text{A.2.4})$$

where denotes the mean interarrival time. Consider the two cases where  $A^*$  is exponential and deterministic with the same mean  $\lambda^{-1}$

$$A_1^*(s) = \frac{\lambda}{\lambda + s}, \quad (\text{A.2.5})$$

$$A_2^*(s) = \exp\left(-\frac{s}{\lambda}\right). \quad (\text{A.2.6})$$

The distribution function corresponding to  $A_1^*$  is larger for convex ordering than the one corresponding to  $A_2^*$ . However,  $\sigma_1 > \sigma_2$  so that  $d_1 < d_2$ .

*2 - A stationary queueing system where an increased variability of interarrivals increases the variability of interdeparture times.*

Consider a stable D/D/1 queue. Let  $\lambda$  denote the intensity of the arrival process. The stationary interdeparture times have deterministic distribution with mean  $\lambda^{-1}$ . Here, an increased variability of interarrivals increases the variability of interdeparture times.

### Appendix 3

In this section, weak convergence of distribution functions on  $R$  will be denoted as  $\Rightarrow$ . We establish first that under the assumptions of Theorem 12

$$D_n^j \Rightarrow D_\infty^j \quad (\text{A.3.1})$$

and

$$\hat{D}_n^j \Rightarrow \hat{D}_\infty^j \quad (\text{A.3.2})$$

when  $n$  goes to  $\infty$ , where  $D_\infty^j$  and  $\hat{D}_\infty^j$  are proper distribution functions on  $R^+$ . We establish the convergence (A.3.2) first. The property is first proved for  $j$  such that  $p(j) = \emptyset$ . For such a  $j$ ,  $\hat{D}_n^j$  represents the distribution function of the  $n$ -th waiting time in a GI/GI/1 FIFO queue and classical results in queueing theory [Co 85] can be used to establish (A.3.1) provided  $E[\sigma_n^j] < E[\tau_n]$ .

The convergence (A.3.2) is now established by induction for all  $B_0 \leq j \leq B$ . Assume queues  $1, \dots, j-1$  to be in steady state for some  $j$  such  $B_0 < j < B$ . Then equations (5.2.6) and (5.2.7) read respectively

$$\hat{D}_0^j = A^j \quad (\text{A.3.3})$$

and

$$\hat{D}_{n+1}^j = A^j \cdot (\hat{D}_n^j * \Sigma^j * T^-), \quad n \geq 0, \quad (\text{A.3.4})$$

where

$$A^j = \prod_{i \in p(j)} \hat{D}_\infty^i * \Sigma^i. \quad (\text{A.3.5})$$

Let  $\{\alpha_n^j\}_{-\infty}^{\infty}$ ,  $\{\sigma_n^j\}_{-\infty}^{\infty}$  and  $\{\tau_n\}_{-\infty}^{\infty}$  be independent sequences of i.i.d. RV's with respective distribution functions  $A^j$ ,  $\Sigma^j$  and  $T^-$ . Consider the  $R^+$ -valued Markov chain  $\{y_n^j\}_0^{\infty}$  defined by the recursion

$$y_{n+1}^j = \max(\alpha_{n+1}^j, y_n^j + \sigma_n^j - \tau_n), \quad n \geq 0, \quad (\text{A.3.6})$$

where

$$y_0^j = \alpha_0^j. \quad (\text{A.3.7})$$

Using the independence assumptions, it is plain from (A.3.3)-(A.3.5) that  $df(y_n^j) = \hat{D}_n^j$  for all  $n \geq 0$ .

Denote  $\alpha_0^j$ ,  $\sigma_0^j$  and  $\tau_0$  as  $\alpha^j$ ,  $\sigma^j$  and  $\tau$  respectively. Using the same formalism as in Appendix 1, define the Loynes' schema  $\{z_n^j\}_0^{\infty}$  by the recursion

$$z_{n+1}^j \circ \theta = \max(\alpha^j \circ \theta, z_n^j + \sigma^j - \tau), \quad n \geq 0, \quad (\text{A.3.8})$$

where

$$z_0^j = \alpha^j. \quad (\text{A.3.9})$$

One proves as in Appendix 1 that  $z_n^j$  increases pathwise with  $n$ ,  $z_n^j =_{st} y_n^j$  for all  $n \geq 0$  and

$$z_{n+1}^j \circ \theta - z_n^j \leq \alpha^j \circ \theta + \sigma^j - \tau. \quad (\text{A.3.10})$$

The integrability assumptions are then used in (A.1.10) to prove that the RV's  $\{z_n^j\}_0^{\infty}$  are bounded from above by an integrable RV. The remainder of the proof is as in Appendix 1.

The numerical schema (7.2.5)-(7.2.6) is a mere rephrasing of equations (A.3.3)-(A.3.5), so that its convergence towards the solution of (7.2.1) is a direct consequence of (A.3.2).

We prove now the convergence (A.3.1). It was established in Theorem 11 that under the assumption  $H_2$

$$D_n^j \leq_{st} \hat{D}_n^j, \quad n \geq 0, \quad j = 1, B. \quad (\text{A.3.11})$$

It follows from the discussion of Appendix 1 that

$$D_n^j = df(\delta_n^j), \quad n \geq 0, \quad j = 1, B. \quad (\text{A.3.12})$$

Hence, the convergence (A.3.2) of  $\hat{D}_n^j$  towards a finite distribution function used in (A.3.11) entails that the increasing sequence  $\delta_n^j$  cannot converge to  $\infty$  almost surely, which establishes (A.3.1).

FIGURE 1

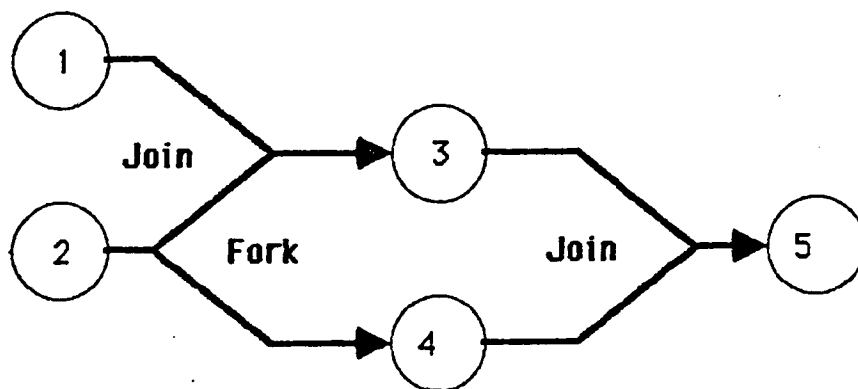

(a)

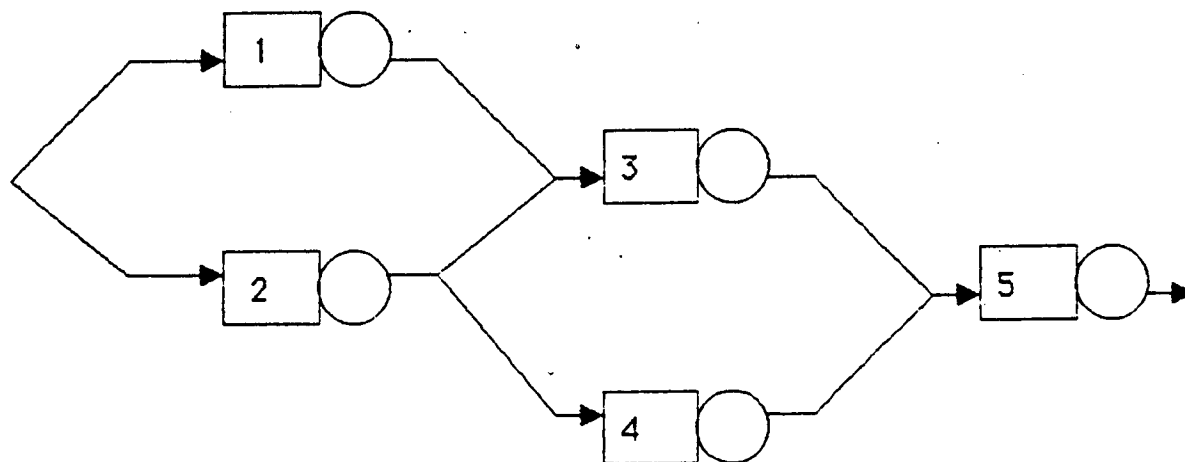

(b)

(a) A program

(b) The associated  
Fork join  
Queueing network

FIGURE 2

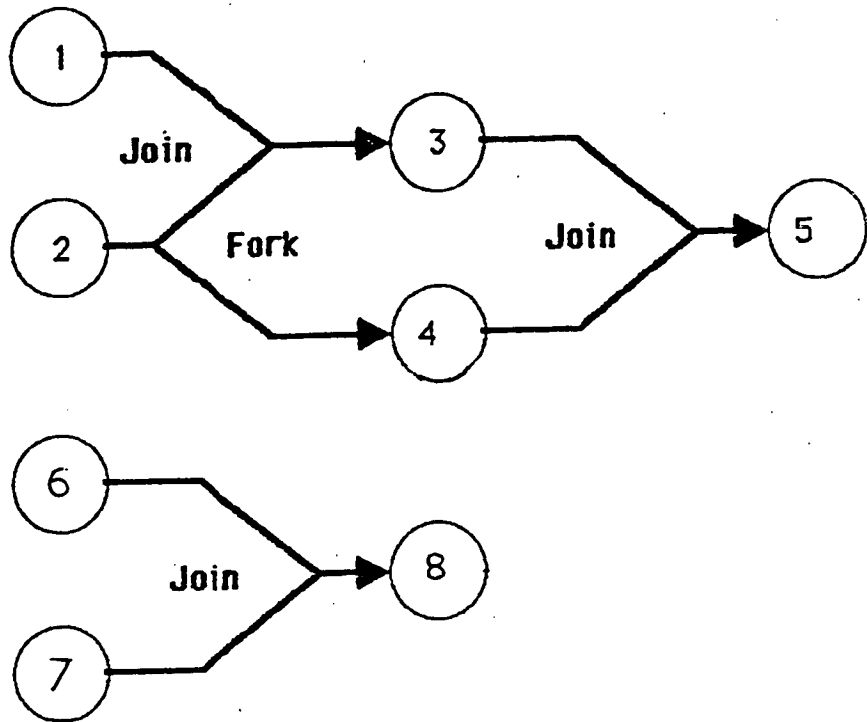

(a)

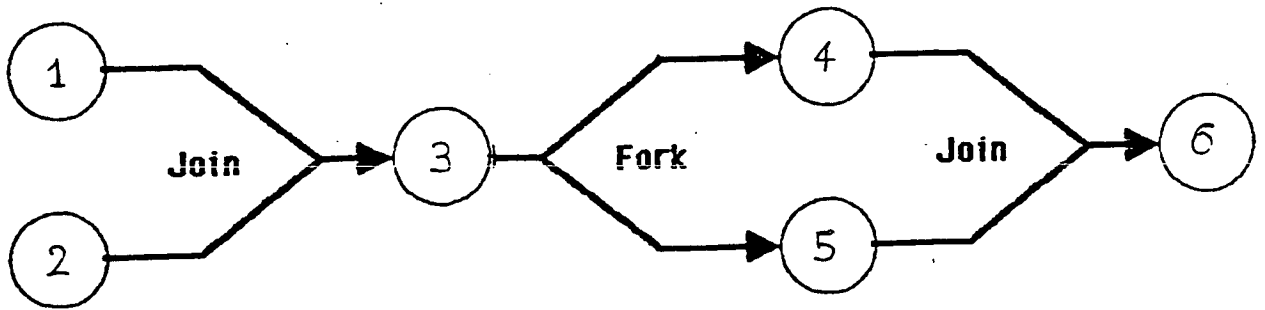

(b)

(a) A parallel network

(b) A series network

FIGURE 3

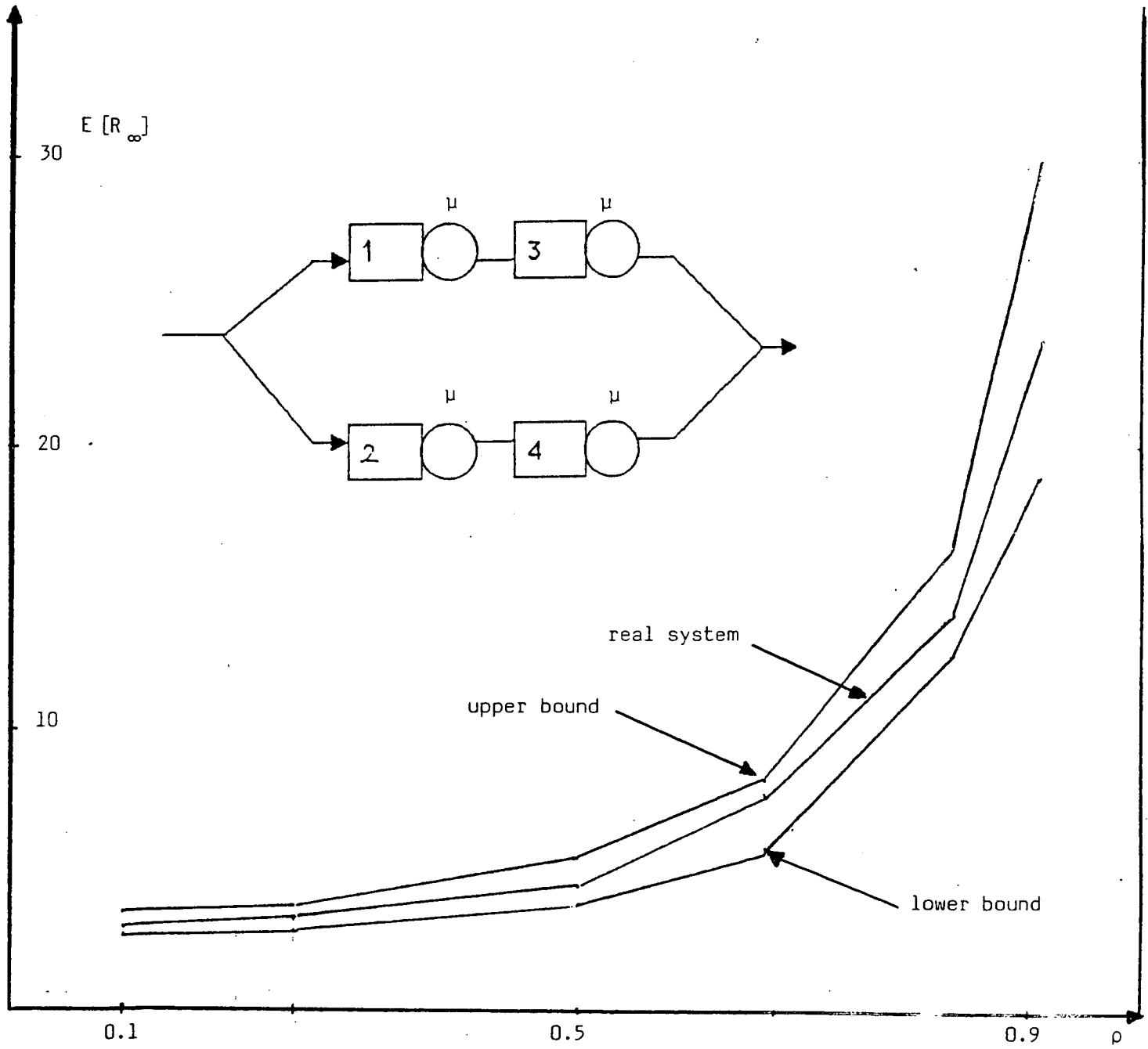

Arrival process : Poisson of parameter  $\lambda$

Service times : exponentially distributed of parameter  $\mu$



## BIBLIOGRAPHY

- [Ba 85] F. Baccelli. "Two Parallel Queues Created by Arrivals with Two Demands: The M/G/2 Symmetrical case," Report INRIA No. 426, July 1985.
- [BGP 84] F. Baccelli, E. Gelenbe and B. Plateau. "An End to End Approach to the Resequencing Problem," *JACM*, VI. 31 No. 3, July 1984, pp.474-485.
- [BM 85] F. Baccelli, A. Makowski, "Simple Computable Bounds for the Fork-Join Queue," *Proc. Conf. Inform. Sci. Systems*, John Hopkins Univ. pp 436-441. March 1985.
- [BM 85b] F. Baccelli, W.A. Massey, "Series-Parallel, Fork-Join Queueing Networks and Their Stochastic Ordering," AT&T Bell Laboratories Memorandum, May 1985.
- [BM 86] F. Baccelli, A. Makowski. "Stability and Bounds for Single Server Queues in Random Environment," *Stochastic Models*, Vol.2, n. 2, Marcel Dekker. 1986.
- [BMS 87] F. Baccelli, A. Makowski and A. Shwartz, " Fork-Join Queue and related systems with synchronization constraints: Stochastic ordering, approximations and computable bounds ," Electrical Engineering Technical Report, University of Maryland, College Park, Jan. 87.
- [BMT 87] F. Baccelli, W. A. Massey and D. Towsley, "Acyclic Fork-Join Queueing Networks", Internal Report, Computer Sc. Dept., University of Massachusetts, April 1987.
- [BP 75] R. Barlow, F. Proschan, "Statistical Theory of reliability and life testing," Holt, Rinehart and Winston, 1975.
- [Br 75] P. Brinch Hansen, " The Programming Language Concurrent Pascal," *IEEE Trans. Soft. Engng.*, SE-1, pp. 199-207, June 1975.
- [FH 84] L. Flatto, S. Hahn, "Two Parallel Queues Created by Arrivals with Two Demands,I," *SIAM J. Appl. Math.* Vol. 44, pp. 1041-1053, 1984.
- [Co 82] J.W. Cohen . " The Single Server Queue," North Holland, 1982.
- [Ha 84] B. Hajek. " The Proof of a Folk Theorem on Queueing Delay with Applications to Routing in Networks," *JACM* Vpl. 30, pp. 834-851, 1983.
- [HHK 79] U. Herzog, W. Hoffmann, W. Kleinöder, "Performance Modeling and Evaluation for Hierarchically Organized Multiprocessor Computer Systems," proceedings of the international conference on parallel processing, 1979, pp. 103-114.
- [Ho 78] C.A.R. Hoare, *Communicating Sequential Processes*, Prentice-Hall International, London, 1985.
- [Ho 79] W. Hoffmann, "Queueing Models for Parallel Processing and their Application to a Hierarchically Organized Multiprocessing System," *Proc. 1st European Conf. Parallel Distr. Proc.*, Toulouse France, pp. 221-227, Feb. 1979.
- [KW 85] C.P. Kruskal, A. Weiss. "Allocating Independent Subtasks on Parallel Processors," *Trans. Soft. Engng.* SE-11, pp. 1001-1016, Oct. 1985.
- [Ma 85] W.A. Massey, "Asymptotic Analysis of the Time Dependent M/M/1 Queue," *Mathematics of Operations Research*, Vol. 10, No. 2, May 1985, pp 305-327.
- [Nels85] R. Nelson, A.N. Tantawi, "Approximate Analysis of Fork/Join Synchronization in Parallel Queues," IBM Report RC11481, Oct. 1985.

- [NTT 87] R. Nelson, D. Towsley, A.N. Tantawi, "Performance Analysis of Parallel Processing Systems," to be presented at SIGMETRICS'87, 1987.
- [Py 81] I.C. Pyle, *The Ada Programming Language*, Prentice-Hall International, London, 1981.
- [Ro 83] T Rolski, "Comparison Theorems for Queues with dependent inter-arrival times ", Modelling and Performance Evaluation Methodology, *Lecture Notes in Control and Information Sciences*, 60, Springer Verlag, 1984.
- [Si 87] K. Sigman, "Regeneration in Queues with Regenerative Input," submitted to *Queueing Systems*.
- [St 84] D. Stoyan. *Comparison Methods for Queues and Other Stochastic Models*, English translation (D.J. Daley editor), J. Wiley and Sons, New York, 1984.
- [TY 87] D. Towsley and S.P. Yu. "Bounds for Two Server Fork-Join Queueing Systems," submitted to *Operations Research*.
- [Wh 81] W. Whitt. "Comparing and Counting Processes and Queues," *Adv. Appl. Prob.* Vol. 13, pp. 207-220, 1981.
- [Wh 84] W. Whitt. "Minimizing Delays in the GI/G/1 Queue," *Opns. Res.* Vol. 32, pp. 41-51, 1984.

