



**HAL**  
open science

## Equivalence, reversibility and symmetry properties in fork/join queueing networks with blocking

Yves Dallery, Zhen Liu, Don Towsley

► **To cite this version:**

Yves Dallery, Zhen Liu, Don Towsley. Equivalence, reversibility and symmetry properties in fork/join queueing networks with blocking. [Research Report] RR-1267, INRIA. 1990. inria-00075292

**HAL Id: inria-00075292**

**<https://inria.hal.science/inria-00075292v1>**

Submitted on 24 May 2006

**HAL** is a multi-disciplinary open access archive for the deposit and dissemination of scientific research documents, whether they are published or not. The documents may come from teaching and research institutions in France or abroad, or from public or private research centers.

L'archive ouverte pluridisciplinaire **HAL**, est destinée au dépôt et à la diffusion de documents scientifiques de niveau recherche, publiés ou non, émanant des établissements d'enseignement et de recherche français ou étrangers, des laboratoires publics ou privés.

# INRIA

UNITÉ DE RECHERCHE  
INRIA-SOPHIA ANTIPOLIS

Institut National  
de Recherche  
en Informatique  
et en Automatique

Domaine de Voluceau  
Rocquencourt  
B.P.105  
78153 Le Chesnay Cedex  
France  
Tél.: (1) 39 63 55 11

## Rapports de Recherche

N° 1267

*Programme 3*  
*Réseaux et Systèmes Répartis*

### **EQUIVALENCE, REVERSIBILITY AND SYMMETRY PROPERTIES IN FORK/JOIN QUEUEING NETWORKS WITH BLOCKING**

**Yves DALLERY**  
**Zhen LIU**  
**Don TOWSLEY**

**Juillet 1990**



★ R R - 1 2 6 7 ★

# Equivalence, Reversibility and Symmetry Properties in Fork/Join Queueing Networks with Blocking

Yves Dallery  
Laboratoire MASI  
Université Pierre et Marie Curie  
4, place Jussieu, 75252 Paris Cedex 05  
FRANCE

Zhen Liu  
INRIA Centre Sophia Antipolis  
2004 route des Lucioles  
06565 Valbonne  
FRANCE

Don Towsley\*  
Department of Computer & Information Science  
University of Massachusetts  
Amherst, MA 01003  
U.S.A.

June 19, 1990

## Abstract

In this paper we study quantitative as well as qualitative properties of Fork/Join Queueing Networks with Blocking (FJQN/B's). Specifically, we prove theorems regarding the equivalence of the behavior of a FJQN/B and that of its *duals*, of a circuit-free FJQN/B, and a *strongly connected marked graph*. In addition, we obtain general conditions that must be satisfied by the service times to guarantee the existence of a long term throughput and its independence on the initial configuration. We also establish conditions under which the reverse of a FJQN/B has the same throughput as the original network. Last, by combining the equivalence results for duals and the reversibility results, we establish a symmetry property for the throughput of a FJQN/B.

**Keywords:** Queueing theory, Fork/Join queueing networks, blocking before service, equivalence, duality, reversibility, symmetry, throughput, marked graphs.

---

\*The work by this author was supported in part by the National Science Foundation under grant ASC 88-8802764 and by the Office of Naval Research under grant ONR N00014-87-K-0796. It was performed while the author was visiting Laboratoire MASI, UPMC, Paris.

# Propriétés d'Equivalence, de Réversibilité et de Symétrie dans les Réseaux Fork/Join avec Blocage

Yves Dallery  
Laboratoire MASI  
Université Pierre et Marie Curie  
4, place Jussieu, 75252 Paris Cedex 05  
FRANCE

Zhen Liu  
INRIA Centre Sophia Antipolis  
2004 route des Lucioles  
06565 Valbonne  
FRANCE

Don Towsley  
Department of Computer & Information Science  
University of Massachusetts  
Amherst, MA 01003  
U.S.A.

June 19, 1990

## Abstract

Dans cet article, nous analysons les propriétés qualitatives et quantitatives de réseaux de files d'attente de type fork/join avec blocage (FJQN/B). Nous montrons des théorèmes relatifs à l'équivalence du comportement d'un FJQN/B avec le comportement de l'un quelconque de ses duals, d'un réseau sans circuit, et d'un graphe d'événements fortement connexe. Nous obtenons des conditions générales pour l'existence du débit et son indépendance par rapport aux conditions initiales. Enfin, nous établissons des propriétés de réversibilité et de symétrie.

**Mots-Clès:** Théorie des files d'attente, réseaux de files d'attente Fork/Join, blocage avant service, équivalence, dualité, réversibilité, symétrie, débit, graphes d'événements.

# 1 Introduction

A Fork/Join Queueing Network with Blocking (FJQN/B) is a queueing network consisting of a set of servers and a set of buffers such that each buffer has exactly one upstream server and one downstream server. On the other hand, each server may have several input buffers and/or several output buffers. Some servers may have no input buffers or no output buffers. Such servers are referred to as sources and sinks, respectively. All the buffers have finite capacity. A server is allowed to start service whenever there is at least one job in each of its input buffers and one empty space (hole) in each of its output buffers, i.e., the server is neither starved nor blocked. Sources are never starved and sinks are never blocked. Upon completion of the service, one job is removed from each of the input buffers and one job is added to each of its output buffers. The FJQN/B, as described above, was first introduced by Ammar and Gershwin [1]. Note that the blocking mechanism in a FJQN/B corresponds to the so-called blocking-before-service mechanism [27].

A FJQN/B is structurally characterized by a graph representing the links between the set of servers and the set of buffers, and the set of buffer capacities. Moreover, the behavior of a FJQN/B in general depends on an initial marking, which is defined as the number of jobs present in each buffer at the initial instant. Finally, since we are mainly interested in the quantitative behavior, a FJQN/B is further characterized by the durations of service times which are Random Variables (RV's).

In this paper we focus on four aspects of FJQN/B's, 1) their equivalence properties including duality, 2) the existence and uniqueness properties of their throughput, 3) their reversibility properties, and 4) their symmetry properties.

**Equivalence Properties.** The first equivalence property that we study is that of *duality*. The duality property of FJQN/B's is related to the concept of job/hole duality introduced by Gordon and Newell [17] within the context of closed tandem queueing networks, and earlier observed by Sevast'yonov [29]. The idea is that the movement of jobs moving in one direction is equivalent to the movement of holes in the opposite direction. This duality concept was generalized to FJQN/B's by Ammar and Gershwin [1]. A dual FJQN/B is obtained by reversing the direction of the flow in any number of buffers and changing the corresponding initial marking to the number of holes initially present. The full dual is a dual FJQN/B for which all the flows have been reversed. We show that any dual FJQN/B, and in particular the full dual, has exactly the same behavior as the original FJQN/B. As a consequence, they have the same throughput and the same stationary marking (with markings replaced by holes when the flow of the corresponding edges is changed) distribution, provided that these quantities exist. These results were already obtained by Ammar and Gershwin [1] in the special case of exponentially distributed service times. We also introduce a canonical form for FJQN/B's where there exists

at most one edge between two servers. We show that for any FJQN/B, there exists a FJQN/B in canonical form that exhibits an equivalent behavior. Using the duality property, we show that it is possible to construct, from any FJQN/B, a circuit-free FJQN/B in canonical form that has the same behavior. Last, we show the equivalence between the class of FJQN/B's and the class of *strongly connected marked graphs* (SCMG's) [10].

**Existence and Uniqueness Properties.** We prove the existence of the throughput of a FJQN/B under very general conditions on the service times. Specifically, we require that the service times of the servers be jointly stationary and ergodic, and be integrable (i.e., have finite means). This existence property was first proved by Baccelli [3] within the context of SCMG's. Our primary new result concerning this part of the problem is that the throughputs of a FJQN/B under two different initial markings are equal, provided that these two markings are reachable from each other and the service times of different servers are independent of each other. Because of the equivalence of FJQN/B's and SCMG's, this result also holds for SCMG's thus proving a basic assumption made in [4] for deriving stability conditions of marked graphs. In the process of proving this result, we also show the following property that may be of independent interest: a FJQN/B (resp. SCMG) within which a server (resp. transition) is frozen, not allowed to serve jobs (resp. not allowed to fire), will reach a marking that is independent of different initial markings that are reachable from each other.

**Reversibility Properties.** For any FJQN/B with an initial marking, we define the reverse FJQN/B to be the network obtained by reversing the flows of jobs while keeping the same initial marking. We show that the reverse FJQN/B has the same throughput as the original FJQN/B provided that the service times form jointly stationary reversible ergodic sequences of integrable random variables. Transient results are also derived. This generalizes the results established in [11] for closed tandem queueing networks. As an application of these results, one can also obtain the reversibility property for tandem queueing systems with finite buffers and blocking-after-service mechanism, and relax the statistical assumption of independent identically distributed (i.i.d.) service times made in [20,21,31]. Such applications are dealt with in a separate paper [12].

**Symmetry Properties.** Finally, we establish some symmetry properties of the throughput of a FJQN/B. We consider a FJQN/B with a given initial marking and the same FJQN/B with the symmetrical initial marking, that is the initial marking corresponding to the hole entities. We show that these two FJQN/B's have the same throughput by combining the results on reversibility and duality. Such a symmetry property was first conjectured by Onvural and Perros [25] for closed tandem queueing networks with blocking before service mechanism and exponential distributions of service times, and first proved by Dallery and Towsley [11] under phase type distributions of service times.

Note that the assumptions required for obtaining the throughput, reversibility, and symmetry properties include independent and identically distributed (i.i.d.) sequences of service times as a special case.

FJQN/B's are of interest because they are particularly suited to model problems in manufacturing, parallel processing, and communication networks. In the case of manufacturing, forking corresponds to the process of splitting the assembly of a component into the subassembly of two or more subcomponents. Joining corresponds to the assembly of two or more subcomponents into a single component. Examples of the study of fork/join queueing networks (also called assembly/disassembly networks) in manufacturing can be found in [13,16]. The FJQN/B also captures the behavior of parallel programming constructs such as the *fork-join* primitive available in many parallel programming languages, [2,18,28]. Some of the many papers that have been devoted to the study of such behavior include [7,6,22]. Most of these studies assume infinite buffering. Last, FJQN/B's have been used to model problems in error control [8,9] and flow control [14] in communication networks.

The paper is organized as follows. The formal definition of FJQN/B's is given in Section 2. The equivalence properties of FJQN/B's are described in Section 3. Sections 4 and 5 contain the results pertaining to the qualitative and throughput behaviors of FJQN/B's, respectively. Reversibility and symmetry properties are presented in Sections 6 and 7, respectively. Some extensions and applications are discussed in Section 8, and finally some concluding remarks are made in Section 9.

## 2 Fork/Join Queueing Networks with Blocking

A Fork/Join Queueing Network with Blocking (FJQN/B) is generally represented as a bipartite graph satisfying certain constraints. Let

$$\mathcal{N} = (V_s, V_b, E, B)$$

be a FJQN/B where  $V_s$  is a set of  $n_s$  servers,  $V_b$  is a set of  $n_b$  buffers,  $E \subset V_s \times V_b + V_b \times V_s$  is a set of directed edges indicating the flow of jobs from servers to buffers and from buffers to servers<sup>1</sup>. Here  $E$  is required to satisfy the constraint that  $|\{(i, k) \in E : i \in V_s\}| = 1$  and  $|\{(k, i) \in E : i \in V_s\}| = 1, \forall k \in V_b$ , i.e., each buffer has one incoming and one outgoing edge. The buffers are of finite capacity with sizes given by  $B = (B_1, \dots, B_{n_b})$  where  $B_k \in \mathbb{IN}^+$  is the capacity of buffer  $k \in V_b$ . It is convenient to refer to the underlying graph,  $G = (V = V_s + V_b, E)$  which is assumed to be connected. We will abuse notation for the sake of readability by labeling the servers  $i = 1, \dots, n_s$  and the buffers as  $k = 1, \dots, n_b$ .

---

<sup>1</sup>When  $A$  and  $B$  are sets,  $A + B = A \cup B$  and  $A - B = \{a : a \in A, a \notin B\}$

Define a set of immediate server predecessors of server  $i \in V_s$ ,  $p_s(i)$ , to be the set of servers that can reach  $i$  without passing through any other server,

$$p_s(i) = \{j \in V_s \mid \exists k \in V_b : (j, k), (k, i) \in E\}$$

and the set of immediate server successors of server  $i \in V_s$ ,  $s_s(i)$ , to be the set of servers to which  $i$  can reach without passing through any other servers,

$$s_s(i) = \{j \in V_s \mid \exists k \in V_b : (i, k), (k, j) \in E\}.$$

Define a set of immediate buffer predecessors of server  $i \in V_s$ ,  $p_b(i)$ , to be the set of buffers that have a direct link to  $i$ ,

$$p_b(i) = \{k \in V_b \mid (k, i) \in E\}$$

and the set of immediate buffer successors of server  $i \in V_s$ ,  $s_b(i)$ , to be the set of buffers to which  $i$  has direct links,

$$s_b(i) = \{k \in V_b \mid (i, k) \in E\}.$$

The FJQN/B behaves in the following manner. Server  $i$  initiates a *service period* whenever there resides at least one job in each of the buffers in  $p_b(i)$  and there is space for at least one job in each of the buffers in  $s_b(i)$ . Server  $i$  is said to be *starved* if at least one of the immediate upstream buffers is empty and *blocked* if at least one of the immediate downstream buffers is full. Note that the server can simultaneously be starved and blocked. Jobs remain in the buffers in  $p_b(i)$  throughout the service period, i.e., there is no space associated with the servers for storing jobs. At the completion of the service period, a job is removed from each of the buffers in  $p_b(i)$  and a job is immediately placed in each of the buffers in  $s_b(i)$ . Observe that the blocking corresponds to what is referred to as *blocking before service* in the literature [27]. Note that a FJQN/B thus defined allows no routing choices.

There may be some servers for which there are no incoming edges. Each such server is referred to as a *source*, and it is assumed that there are an infinite number of jobs available to the source so that it is never starved. There may be other servers for which there are no outgoing edges. Each such server is referred to as a *sink*, and is assumed to never be blocked. Each job that completes at a sink leaves the system immediately.

An example of a FJQN/B is given in Figure 1 (servers are represented by circles and buffers are represented by rectangles). This FJQN/B has 10 servers and 12 buffers. Servers 1 and 6 are sources and server 5 is a sink. Two special cases of FJQN/B's that have received much attention are tandem queueing networks (see Figure 2) and closed tandem queueing networks (see Figure 3). Another special class of FJQN/B's which is of interest corresponds to closed series-parallel fork-join networks. An example of such a network is given in Figure 4.



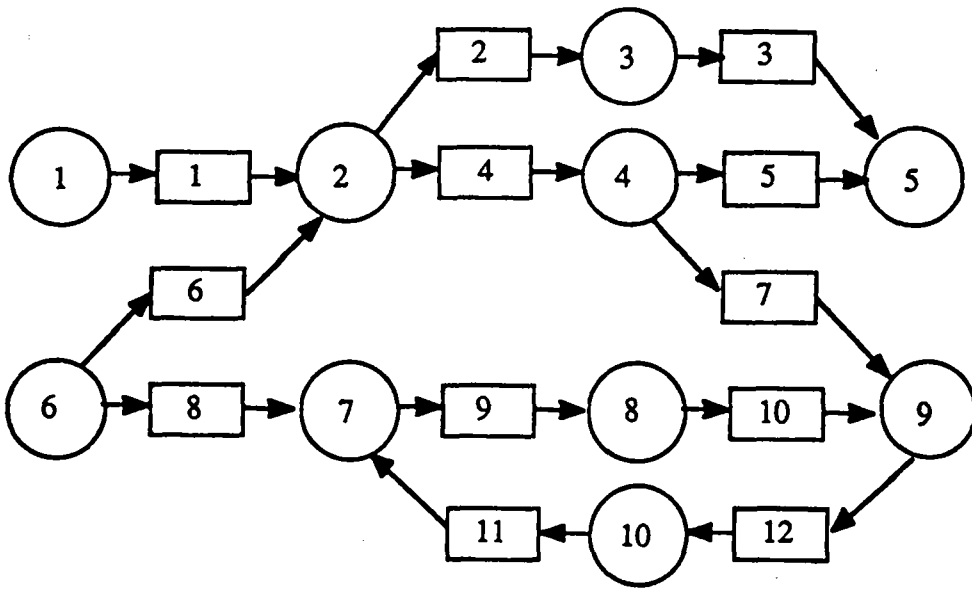

Figure 1: Example of a FJQN/B.

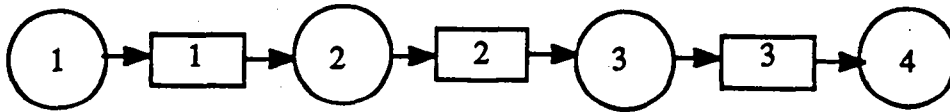

Figure 2: A tandem queueing network.

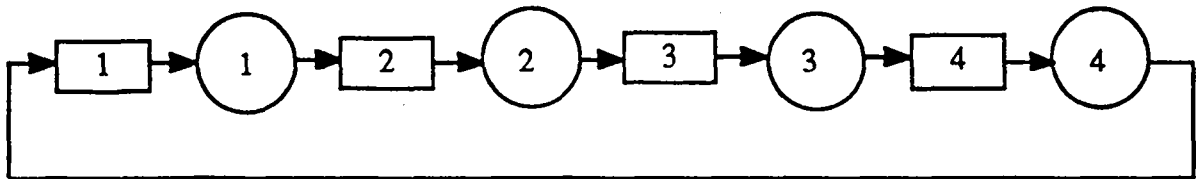

Figure 3: A closed tandem queueing network.

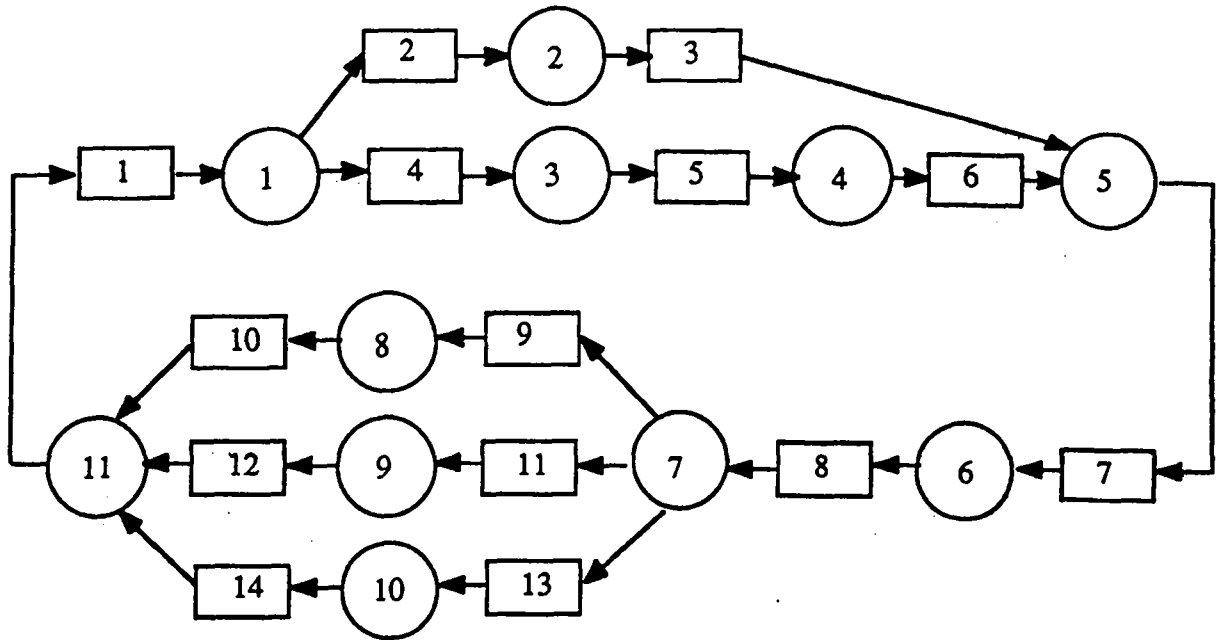

Figure 4: A closed series-parallel fork-join network

**Definition 2.1** A FJQN/B is said to be in canonical form if there is at most one buffer between every pair of servers:

$$|\{k \in V_b \mid (i, k), (k, j) \in E \text{ or } (j, k), (k, i) \in E\}| \leq 1 \quad \forall i, j \in V_s.$$

An alternate, simpler representation of a FJQN/B in canonical form is possible. As much of the paper deals with such FJQN/B's, it is worthwhile describing this representation. In this case  $\mathcal{N} = (V_s, E, \mathbf{B})$  where  $V_s$  is a set of servers and  $E \subset V_s \times V_s$  is a set of directed edges indicating the flow of jobs from servers to servers. In this formulation, the buffers are associated with the edges, i.e., there is a mapping  $\pi$  from edges to buffers,  $\pi : E \rightarrow V_b$ . The vector  $\mathbf{B}$  retains its original meaning although it is sometimes convenient to refer to the edge, i.e.,  $B_{i,j} = B_{\pi(i,j)}$ . It remains convenient to refer to the underlying graph,  $G = (V = V_s, E)$ . Similar definitions for the sets of immediate server predecessors and immediate server successors to server  $i \in V_s$  can be given. We will show in Section 3.2 that for every FJQN/B, there exists a FJQN/B in canonical form exhibiting the same behavior. Throughout the paper, we will use this simpler representation whenever we restrict our attention to FJQN/B's in canonical form. Note that the FJQN/B given in Figure 1 is in canonical form. Its simplified representation is given in Figure 5.

We introduce some terminology from graph theory related to the underlying graph,  $G$ . A *path* from node  $i_1$  to node  $i_j$  both in  $V$  is a sequence of contiguous edges,  $(i_1, i_2), (i_2, i_3), \dots, (i_{j-1}, i_j)$  that are in  $E$ . A *circuit*,  $C$ , is a path with  $i_1 = i_j$ . A *chain* is a sequence of undirected contiguous edges,  $(i_1, i_2), (i_2, i_3), \dots, (i_{j-1}, i_j)$  such that either  $(i_l, i_{l+1}) \in E$  or  $(i_{l+1}, i_l) \in E$ . A *cycle*,  $C$ ,

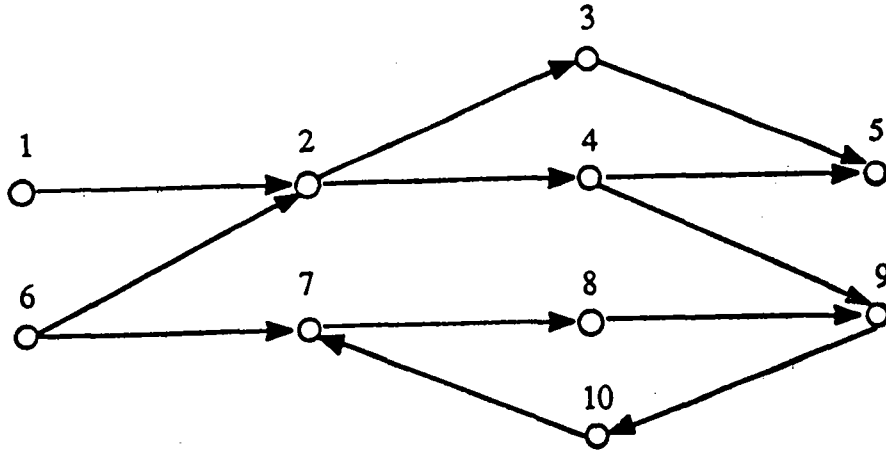

Figure 5: Canonical Representation of the FJQN/B in Figure 1

is a chain with  $i_1 = i_j$ . We refer to the set of edges associated with either a circuit or cycle  $C$  as  $E(C) \subseteq E$ . Throughout the paper we will only consider *elementary* circuits and cycles, i.e., those containing no subcircuits or subcycles. For simplicity we will use the terms *circuit* and *cycles* to mean elementary circuits and elementary cycles. Note that all circuits are cycles but not viceversa. The reader should be careful to remember the definitions of these terms as they are not always consistent with their definitions sometimes introduced in the theory of queueing networks.

In the FJQN/B of Figure 1, there is a single circuit and several cycles. The circuit consists of the set of edges  $\{(7, 8), (8, 9), (9, 10), (10, 7)\}$  and a cycle is, for instance, defined by the set of edges  $\{(2, 3), (3, 5), (5, 4), (4, 2)\}$ . A tandem queueing network has no cycles while a closed tandem queueing network is a FJQN/B which consists just of a single circuit.

Two classes of FJQN/B's are of particular interest:

- *Circuit-free FJQN/B's*: A circuit-free FJQN/B is one that contains no circuits.
- *Cycle-free FJQN/B's*: A cycle-free FJQN/B is one that contains no cycles.

A circuit-free FJQN/B and a cycle-free FJQN/B are illustrated in Figures 6 and 7, respectively. It is easy to check that the number of buffers in a cycle-free FJQN/B is equal to the number of servers minus one, i.e.,  $n_b = n_s - 1$ . Note that a tandem queueing network (see Figure 2) is a special case of cycle-free FJQN/B's. Hence, any comment that will be made regarding cycle-free FJQN/B's is especially true for tandem queueing networks.

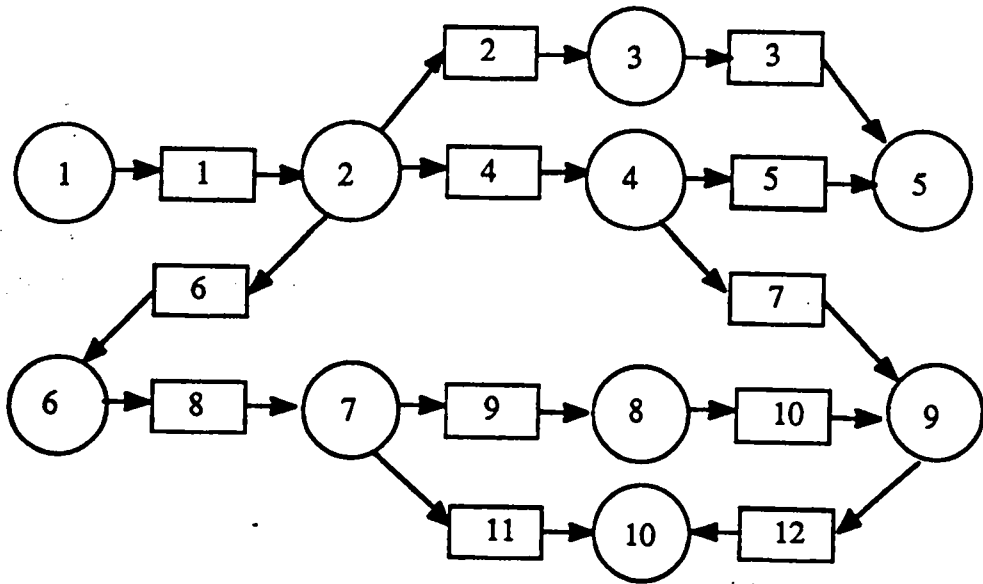

Figure 6: Example of a circuit-free FJQN/B.

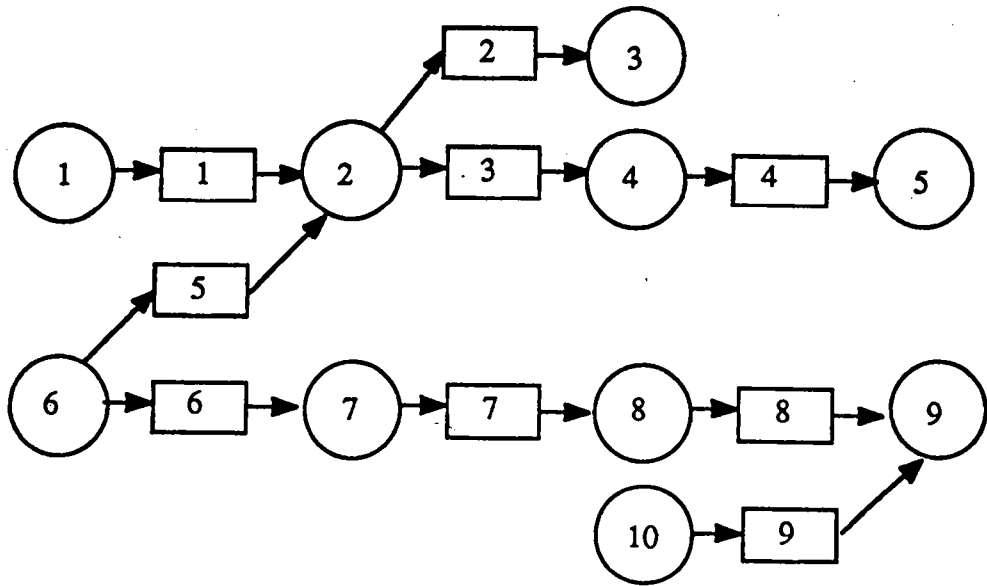

Figure 7: Example of a cycle-free FJQN/B.

Let  $\mathbf{m}(t) = (m_1(t), \dots, m_{n_b}(t))$  be the *marking* of the system at time  $t \geq 0$  where  $m_k(t)$  denotes the number of jobs in buffer  $k \in V_b$  at time  $t$ . The initial marking at time  $t = 0$  is assumed to be  $\mathbf{m}(0) = \mathbf{M} = (M_1, \dots, M_{n_b})$ ,  $M_k \in \{0, 1, \dots, B_k\}$ ;  $k \in V_b$ . In general, the qualitative as well as quantitative behavior of a FJQN/B are related to its initial marking. Hence we introduce the notation

$$\mathcal{S} = (\mathcal{N}, \mathbf{M})$$

to denote the FJQN/B  $\mathcal{N}$  associated with the initial marking  $\mathbf{M}$ .

When the FJQN/B is in canonical form, we will often refer to the initial marking of the buffer associated with edge  $(i, j) \in E$  as  $M_{i,j} = M_{\pi(i,j)}$ . Note that  $B_k - m_k(t)$  is the number of holes (empty spaces) in buffer  $k$  at time  $t$ .

The durations of the service periods at server  $i$  are given by a sequence of non-negative service times,  $\{\sigma_{i,n}\}_{n \geq 1}$ ,  $i \in V_s$ . In addition, there is an initial timing condition  $\mathbf{Y} = (Y_1, \dots, Y_{n_s})$ ,  $Y_i \geq 0$ , after which the  $i$ -th server can begin its first service period,  $i \in V_s$ . We note that service times may take value zero. The introduction of servers whose service periods are of zero length is useful for modeling synchronization mechanisms. Denote by

$$\mathcal{T} = (\mathcal{S}, \mathbf{Y})$$

the FJQN/B  $\mathcal{S}$  coupled with the initial timing condition  $\mathbf{Y}$ . Note that this timing condition can be correlated with the service times.

The performance measure of greatest interest to us is the system throughput. Let  $D_{i,n}(\mathcal{T})$  denote the time of the  $n$ -th service completion at server  $i$  in  $\mathcal{S}$  under initial timing condition  $\mathbf{Y}$ . Let

$$D_n(\mathcal{T}) = \max_{i \in V_s} D_{i,n}(\mathcal{T}).$$

Denote by  $\theta_i(\mathcal{T})$  the (asymptotic) throughput of server  $i \in V$  and  $\theta(\mathcal{T})$  the throughput of  $\mathcal{S}$  with initial timing condition  $\mathbf{Y}$ . More precisely,

$$\theta_i(\mathcal{T}) = \lim_{n \rightarrow \infty} \frac{E[D_{i,n}(\mathcal{T})]}{n}, \quad i \in V, \quad (1)$$

$$\theta(\mathcal{T}) = \lim_{n \rightarrow \infty} \frac{E[D_n(\mathcal{T})]}{n} \quad (2)$$

provided the limits exist. We give conditions for the existence of these limits in Section 5. Typically we are interested in  $\theta(\mathcal{S}, \mathbf{0})$ , which will simply be referred to as  $\theta(\mathcal{S})$ .

### 3 Equivalence Properties

In this section we define the dual of a FJQN/B and prove the equivalence of a FJQN/B and its duals. We also establish the equivalence between the general class of FJQN/B's and the class of FJQN/B's in canonical form and the class of circuit-free FJQN/B's in canonical form. Last, we establish the equivalence between the class of FJQN/B's and the class of SCMG's.

#### 3.1 Duality Properties of FJQN/B's

First, we define the operator  $\delta(S, k)$ ,  $k \in V_b$  which produces a new FJQN/B

$$S^d = ((V_s, V_b, E^d, B), M^d)$$

where

$$E^d = E - \{(i, k) \in E\} + \{(k, i) | (i, k) \in E\} - \{(k, j) \in E\} + \{(j, k) | (k, j) \in E\},$$

$$M_l^d = \begin{cases} B_l - M_l, & l = k, \\ M_l, & \text{otherwise.} \end{cases}$$

In other words,  $\delta$  switches the directions of the incoming and outgoing edges to a buffer  $k$  and replaces the holes in that buffer with jobs and jobs with holes.

**Definition 3.1** *The FJQN/B  $S^d = (\mathcal{N}^d, M^d)$  is a dual of  $S = (\mathcal{N}, M)$  if it can be obtained from  $S$  through the application of the dual operator  $\delta$  a finite number of times.*

Note that any dual of a cycle-free FJQN/B is also cycle-free. Of special interest is the following dual of  $S$ .

**Definition 3.2** *The FJQN/B  $S^f = (\mathcal{N}^f = (V_s, V_b, E^f, B), M^f)$  is the full dual of  $S = (\mathcal{N}, M)$  if it is a dual of  $S$  and the direction of all of the edges in  $\mathcal{N}$  have been reversed, in other words,  $E^f = \{(i, j) | (j, i) \in E\}$  and  $M^f = B - M$ . The marking  $M^f$  will be referred to as the symmetrical marking of  $M$ .*

The full dual of the FJQN/B illustrated in Figure 1 is illustrated in Figure 8.

The main result of this section is the equivalence between the FJQN/B  $S$  and a dual  $S^d$ . Let  $S^d = ((V_s, V_b, E^d, B), M^d)$  be a dual of  $S = ((V_s, V_b, E, B), M)$ . Let  $V_b = V_1 + V_2$  where  $V_2$  is the subset of buffers for which the direction has been switched. Thus,

$$M_k^d = \begin{cases} M_k, & k \in V_1, \\ B_k - M_k, & k \in V_2. \end{cases}$$

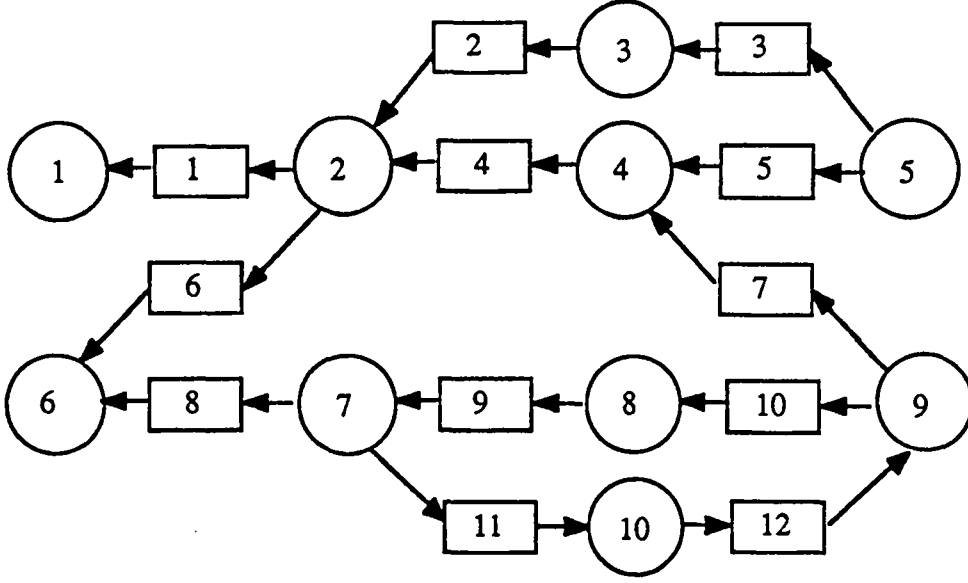

Figure 8: Full Dual of the FJQN/B in Figure 1.

The set of edges  $E$  can be expressed as  $E = E_1 + E_2$  where  $E_1$  (resp.  $E_2$ ) is the subset of incoming and outgoing edges for buffers in  $V_1$  (resp.  $V_2$ ) and  $E^d = E_1 + E_3$  where  $E_3$  is the reverse of the edges in  $E_2$ . Let  $\mathbf{m}(t) = (m_1(t), \dots, m_{n_b}(t))$  and  $\mathbf{m}^d(t) = (m_1^d(t), \dots, m_{n_b}^d(t))$  be the markings of  $S$  and  $S^d$  at time  $t > 0$ .

**Theorem 3.3** Let  $S$  and  $S^d$  be duals as defined above. Define  $\mathbf{d}(t) = (d_1(t), \dots, d_{n_b}(t))$  where

$$d_k(t) = \begin{cases} m_k^d(t), & k \in V_1, \\ B_k - m_k^d(t), & k \in V_2. \end{cases}$$

Then for the same arbitrary sequences of service times and the same arbitrary initial timing conditions,

$$\mathbf{m}(t) =_D \mathbf{d}(t), \quad t > 0, \quad (3)$$

where the symbol " $=_D$ " denotes the equality in distribution.

**Proof.** The proof consists of conditioning the system behavior on the service times and showing by induction on the times of the different events that the departure times are the same in both systems. ■

**Corollary 3.4** *Whenever the throughput exists for  $S$ , the throughput exists for  $S^d$  and is identical to that of  $S$ , i.e. :*

$$\theta(S, Y) = \theta(S^d, Y)$$

*for all initial timing conditions  $Y$ .*

**Corollary 3.5** *Whenever the stationary distribution for the system marking exists for  $S$ , then the stationary distribution for the system marking exists for  $S^d$  and is related to that of  $S$  by (3).*

**Remarks.** General conditions for the existence of the stationary marking distribution of  $S$  are found in Baccelli and Liu [3,5]. In particular, a stationary marking distribution exists when the service times at each server form mutually independent i.i.d. sequences of RV's having infinite support. Hence, the above corollary extends the results of Ammar and Gershwin [1] developed under the assumption of exponential service times at each server. Their method of proof was to construct Markov chain representations of  $S$  and  $S^d$  and show that they are identical. One observes that this approach can be used to extend the results to the case that the service times are described by an arbitrary Markov process, e.g., i.i.d. sequences of service times with a phase type distribution (PH) [23,30]. However, our approach, based on sample path analysis, applies to arbitrary service times and moreover provides results on the transient behavior.

**Remarks.** The duality property provides some insight on the behavior of FJQN/B's. First, it shows that there is no fundamental difference between starvation and blocking mechanisms (recall that we assume blocking before service). Indeed, duality switches around starvation and blocking events. For instance, the starvation of a server due to the empty state of a buffer in the original FJQN/B corresponds to the blocking of the same server due to the full state of the same buffer in the dual FJQN/B. Second, duality shows that there is no fundamental difference between circuits and cycles. Indeed, it is always possible to transform a circuit into a cycle or vice-versa using duality. At first glance, one could think that a circuit-free FJQN/B is with some respect simpler than a general FJQN/B. This is however not true and we will show below that any FJQN/B can actually be transformed into a circuit-free FJQN/B. Finally, duality shows that sources and sinks do not play a special role. Indeed, using duality, a source (or a sink) can be transformed into a regular server and vice-versa, any server can be transformed into a source (or a sink).

### 3.2 FJQN/B's in Canonical Form

We prove the equivalence between the classes of arbitrary FJQN/B's and FJQN/B's in canonical form. First we describe a procedure for transforming an arbitrary FJQN/B  $S = ((V_s, V_b, E, B), M)$



into an FJQN/B  $S^c = ((V_s, V_b^c, E^c, B^c), M^c)$  in canonical form.

#### Algorithm

1. Construct a FJQN/B  $S^d = ((V_s, V_b, E^d, B), M^d)$  that is a dual of  $S$  such that if  $(i, k), (k, j) \in E^d$  for some  $k \in V_b$ , then there is no buffer  $k' \in V_b$  such that  $(j, k'), (k', i) \in E^d$ .

2.  $V_b^c = V_b; E^c = E^d; B^c = B; M^c = M^d;$

For every pair of servers  $i, j \in V_s$  do

$S_{i,j} = \{k \in V_b : (i, k), (k, j) \in E^d\};$

if  $|S_{i,j}| > 1$  then

choose  $k_0 \notin V_b;$

$V_b^c = V_b^c - S_{i,j} + \{k_0\};$

$E^c = E^c - \{(i, k), (k, j) : k \in S_{i,j}\} + \{(i, k_0), (k_0, j)\};$

$M_{k_0}^c = \min_{l \in S_{i,j}} M_l^d;$

$B_{k_0}^c = \min_{l \in S_{i,j}} \{B_l - M_l^d + M_{k_0}^c\};$

end

Observe that the first step of the algorithm ensures that all buffers between any pair of servers are oriented in the same direction. The second step reduces the number of buffers between any pair of servers to one. We state without proof that this new FJQN/B  $S^c$  has the same behavior as  $S$  in the sense that all service periods coincide at all servers. In the remainder of the paper following this section, we only consider FJQN/B's in canonical form.

### 3.3 Circuit-Free FJQN/B's

In this subsection, we show that for an arbitrary FJQN/B  $S$  there exists a circuit-free FJQN/B which exhibits the same behavior. We begin by describing a procedure for converting  $S = (\mathcal{N}, M)$  into a circuit-free FJQN/B  $S^a = (\mathcal{N}^a, M^a)$  in canonical form.

#### Algorithm

begin

$E^a = \emptyset; U = V_s$

for  $i \in V_s$  do

$U = U - \{i\};$

$E^a = E^a + \{(i, k), (k, j) : (i, k), (k, j) \in E, j \in U\}$   
 $+ \{(j, k), (k, i) : (i, k), (k, j) \in E, j \in U\};$

for every  $k \in V_b$  whose incoming and outgoing edge are the same in  $E$  and in  $E^a:$

$M_k^a = M_k;$

for all other  $k \in V_b$ ,  $M_k^a = B_k - M_k$ ;

$S^a = ((V_s, V_b, E^a, B), M^a)$

end

The basic idea of the algorithm is to order all the servers, say  $i_1, \dots, i_n$ , and ensure that the buffers between any pair of neighbor servers  $i_{l_1}$  and  $i_{l_2}$ , where  $l_1 < l_2$ , are oriented towards server  $i_{l_2}$ . Last, note that if  $S^a$  is not in canonical form, it can easily be placed in canonical form without introducing any circuits.

The following result follows directly from the above construction and Theorem 3.3.

**Corollary 3.6** *Given an arbitrary FJQN/B,  $S = ((V_s, E, B), M)$ , there exists a circuit-free FJQN/B  $S^a = ((V_s, V_b^a, E^a, B^a), M^a)$  in canonical form that exhibits the same behavior as  $S$ .*

We note that the FJQN/B of Figure 6 is the circuit-free network obtained from the FJQN/B of Figure 1 by applying the above algorithm.

**Remark.** An analogous algorithm can be devised that transforms a cycle-free FJQN/B into a dual FJQN/B with tree structure.

### 3.4 Equivalence of FJQN/B's and SCMG's

We conclude this section with the observation that the class of FJQN/B's is related to a special class of Marked Graphs (MG), namely Strongly Connected Marked Graphs (SCMG). A MG [10] is a special case of a Petri Net [26] in which each place has only one input and one output transition. Stochastic MG's have recently been analyzed by Baccelli et al. [3,4]. Now, it is easy to show that any SCMG can be modeled as a FJQN/B in canonical form having the same graph. The servers are identified with the transitions of the MG, and the buffers with the places of the MG. Since each place of the MG has only one input and one output transition, this implies that each buffer of the FJQN/B has only one upstream and one downstream server. The initial marking of the FJQN/B is the same as that of the MG. Now, since the MG is strongly connected, the number of tokens in each place is bounded (see e.g. [3]). Thus, the capacity of each buffer of the FJQN/B can be set to the bound of the corresponding place of the MG. Note that these bounds do depend on the initial marking of the MG. It is easy to check that the resulting FJQN/B has exactly the same behavior as the SCMG.

Conversely, any connected FJQN/B can be modeled as a SCMG. Without loss of generality, assume that the FJQN/B is in canonical form. With each server of the FJQN/B is associated a transition of the MG and with each buffer connecting two servers are associated two places connecting the two corresponding transitions in both directions. The initial markings of these

two places are equal to the number of jobs and the number of holes of the corresponding buffer, respectively. Now, since the FJQN/B is connected, this obviously implies that the MG is strongly connected. Again, it is easy to check that the resulting MG has the same behavior as the FJQN/B.

This equivalence between FJQN/B's and SCMG's is of interest for several reasons. On the one hand, it means that all the results presented in this paper can readily be applied to SCMG's. On the other hand, some results can be borrowed from the theory of MG's and adapted to FJQN/B's. This is especially true for qualitative properties presented in the next section.

## 4 Qualitative Behavior of FJQN/B's

In this section we establish some qualitative properties of FJQN/B's. Such properties are similar to those that have been obtained for Marked graphs [10]. Consider a FJQN/B  $\mathcal{S} = (\mathcal{N}, \mathcal{M})$  that is in canonical form. Let  $C$  be a cycle in  $\mathcal{N}$ . Let us define an arbitrary orientation of this cycle. The set of edges  $E(C)$  can be partitioned into two subsets with respect to this reference orientation. Let  $E^+(C)$  be the subset of edges oriented according to the reference orientation and  $E^-(C)$  be the subset of edges oriented in the reverse direction. We have :  $E^+(C) + E^-(C) = E(C)$ . Note that if the reverse orientation is chosen as the reference, then the two subsets are switched around. Also, if  $C$  is a circuit, the natural orientation leads to  $E^+(C) = E(C)$  and  $E^-(C) = \emptyset$ . According to the mapping  $\pi$ , this partition gives rise to a partition of the set of buffers of cycle  $C$  :  $V_b(C) = V_b^+(C) + V_b^-(C)$ .

We define the quantities  $I_C^+(M)$  and  $I_C^-(M)$  to be,

$$\begin{aligned} I_C^+(M) &= \sum_{k \in V_b^+(C)} M_k + \sum_{k \in V_b^-(C)} (B_k - M_k) \\ I_C^-(M) &= \sum_{k \in V_b^-(C)} M_k + \sum_{k \in V_b^+(C)} (B_k - M_k). \end{aligned}$$

Here  $I_C^+(M)$  (respectively  $I_C^-(M)$ ) is the total number of jobs (respectively holes) in all buffers corresponding to the reference direction plus the total number of holes (respectively jobs) in all buffers corresponding to the reverse direction. Note that

$$I_C^+(M) + I_C^-(M) = B_C \equiv \sum_{k \in V_b(C)} B_k$$

and

$$I_C^+(M) = I_C^-(B - M).$$

We have the following invariance property that is satisfied by every cycle in a FJQN/B independent of the service times and initial timing conditions.

**Lemma 4.1** *Let  $C$  be an arbitrary cycle in  $\mathcal{N}$ . The markings in this cycle satisfy the following relation,*

$$\sum_{k \in V_b^+(C)} m_k(t) + \sum_{k \in V_b^-(C)} (B_k - m_k(t)) = I_C^+(M), \quad (4)$$

or equivalently

$$\sum_{k \in V_b^+(C)} (B_k - m_k(t)) + \sum_{k \in V_b^-(C)} m_k(t) = I_C^-(M), \quad (5)$$

independent of the service times and initial timing conditions.

**Proof.** It is easy to check that a service completion at any server belonging to this cycle does not change the above quantities and thus they are invariant and equal to those corresponding to the initial marking. ■

Henceforth we will refer to  $I_C^+(M)$  and  $I_C^-(M)$  as the *invariants* of cycle  $C$ . Note that in the special case where  $C$  is a circuit, the above lemma states that the total number of jobs along this circuit is an invariant. So is the total number of holes. For a closed tandem queueing network this simply means that the total number of jobs in the network is a constant number usually referred to as the population of the network.

We define the following relation between markings.

**Definition 4.2** *Let  $\mathcal{N}$  contain  $n_c$  distinct cycles  $C_1, \dots, C_{n_c}$ . Let*

$$I(M) = (I_1^+(M), I_2^+(M), \dots, I_{n_c}^+(M)).$$

*Then markings  $M$  and  $M'$  are equivalent (written  $M \sim M'$ ) iff  $I(M) = I(M')$ .*

Let  $M$  be a marking, then  $\mathcal{R}(\mathcal{N}, M)$  denotes the set of markings equivalent to  $M$ , i.e.,  $\mathcal{R}(\mathcal{N}, M) = \{M' : M \sim M'\}$ . Marking  $M'$  is said to be reachable from marking  $M$  with respect to  $\mathcal{N}$  if there exists some sequence of service completions (where timing constraints are ignored) such that  $\mathcal{N}$  can transit from  $M$  to  $M'$ . It has been established for untimed marked graphs that marking reachability and marking equivalence, as defined above are the same (see [10]). Hence,  $M$  and  $M'$  are reachable from each other, in the absence of timing constraints, iff  $M \sim M'$ . It follows from Lemma 4.1 that, in the presence of timing constraints, a necessary

condition for a marking  $M'$  to be reachable from a marking  $M$  is that it belong to  $\mathcal{R}(\mathcal{N}, M)$ . Note however that because of timing constraints, it is not, in general, a sufficient condition. In the special case of a cycle-free FJQN/B, since there is no cycle, all markings belong to the same class. For a closed tandem queueing network, all markings corresponding to the same population of the network belong to the same class.

A FJQN/B  $\mathcal{S} = (\mathcal{N}, M)$  is said to be *deadlocked* if it is impossible for any server to commence a service period, i.e., every server is either starved, blocked, or both. The FJQN/B  $\mathcal{S}$  is said to be *deadlock-free* if  $\mathcal{R}(\mathcal{N}, M)$  does not contain any deadlocked marking. We have the following result.

**Theorem 4.3** *A FJQN/B with initial marking  $M$  is deadlock-free iff the following relation is satisfied,*

$$I_C^+(M) > 0 \text{ and } I_C^-(M) > 0, \quad \forall C,$$

or equivalently

$$0 < I_C^+(M) < B_C.$$

**Proof.** This property can easily be obtained from a similar result pertaining to SCMG's [10] using the equivalence between FJQN/B's and SCMG's. ■

Note that if  $C$  is a circuit, the above condition states that there is at least one job and at least one hole along the circuit.

The following result was obtained in the context of MG's (Theorem 6 in [10]) and thus also holds for FJQN/B's.

**Lemma 4.4** *For any sequence of service completions such that the final marking is the same as the initial marking, the number of service completions is the same for all servers.*

Finally, we establish the following result that will be useful in the next section for proving the independence of the throughput with respect to the initial marking. The proof of this result can be found in the Appendix.

**Theorem 4.5** *Let  $S^1 = (\mathcal{N}, M^1)$  and  $S^2 = (\mathcal{N}, M^2)$  be two deadlock-free FJQN/B's that differ only in their initial markings, i.e.,  $M^1 \neq M^2$ . If  $M^1 \sim M^2$ , then by freezing an arbitrary server,  $i$ , in  $\mathcal{N}$ ,  $S^1$  and  $S^2$  reach the same marking  $M$  where every server other than  $i$  is either blocked, starved, or both.*

## 5 Throughput

In this section, we focus on the existence of the asymptotic throughput of an arbitrary FJQN/B and the equivalences, in term of throughput, between the FJQN/B's with different initial timing conditions and markings. Throughout this section, we assume, without loss of generality, that all of the FJQN/B's are in canonical form.

Before establishing the results of this section, we associate a *precedence graph* with the canonical FJQN/B. Let  $\mathcal{S} = ((V_s, E, B), M)$  be an arbitrary deadlock-free FJQN/B. Consider a relation  $\prec_{\mathcal{S}}$  between the pairs  $(i, n)$ , where  $i \in V_s, n \geq 1$ .

**Definition 5.1** *The pairs  $(i, n)$  and  $(j, m)$  have the relation  $(i, n) \prec_{\mathcal{S}} (j, m)$  iff one of the following relations is satisfied,*

$$n = m - M_{i,j}, \quad i \in p_s(j), \quad (6)$$

$$n = m - 1, \quad i = j, \quad (7)$$

$$n = m - (B_{j,i} - M_{j,i}), \quad i \in s_s(j). \quad (8)$$

**Definition 5.2** *The graph  $\mathcal{G}_{\mathcal{S}} = (\mathcal{V}, \mathcal{E})$  is the precedence graph associated with  $\mathcal{S}$  if*

$$\mathcal{V} = \{(i, n) \mid n \geq 1, i \in V_s\}$$

$$\mathcal{E} = \{(i, n) \rightarrow (j, m) \mid (i, n), (j, m) \in \mathcal{V}, (i, n) \prec_{\mathcal{S}} (j, m)\}$$

**Remark.** As we shall see later on, the edges in this graph indicate the ordering in which service periods may commence in  $\mathcal{S}$ . For example, an edge corresponding to relation (6) carries the meaning that the commencement of the  $m$ -th service period at server  $j$  cannot occur before the completion of the  $(n - M_{i,j})$ -th service period at server  $j$ , i.e., buffer  $(i, j)$  must be nonempty. Similar interpretations can be given to the other edges.

**Lemma 5.3** *If  $\mathcal{S}$  is deadlock-free, then the precedence graph  $\mathcal{G}_{\mathcal{S}}$  is circuit-free.*

**Proof.** Suppose there is a circuit

$$C = (i_1, n_1) \rightarrow (i_2, n_2) \rightarrow \cdots (i_k, n_k) \rightarrow (i_1, n_1)$$

in  $\mathcal{G}_{\mathcal{S}}$ ,  $k \geq 1$ . According to relations (6)-(8),

$$n_1 \leq n_2 \leq \cdots \leq n_k \leq n_1$$

which implies that

$$n_1 = n_2 = \dots = n_k,$$

which further implies that  $i_1, i_2, \dots, i_k$  are distinct and form a circuit in  $\mathcal{N}$ . Let  $i_{k+1} = i_1$ . Using now the definition of  $\mathcal{G}_S$ , we obtain that for  $j = 1, \dots, k$ , either

$$i_j \in p_s(i_{j+1}), \quad \text{and} \quad M_{i_j, i_{j+1}} = 0,$$

or

$$i_j \in s_s(i_{j+1}), \quad \text{and} \quad M_{i_{j+1}, i_j} = B_{i_{j+1}, i_j}.$$

Theorem 4.3 can now be applied to show that  $S$  is not deadlock-free. Therefore,  $\mathcal{G}_S$  is circuit-free. ■

We now study the behavior of the throughput of  $S$ . The existence of the limit in equation (2) will be shown in Theorem 5.6 below. We establish first the evolution equations of  $S$  that capture the synchronization mechanisms (e.g., starvation and blocking) of  $S$ .

**Lemma 5.4** *If  $S$  is deadlock-free, then the evolution equations are:*

$$D_{i,1}(S, Y) = \sigma_{i,1} + \max \left( Y_i, \max_{j \in p_s(i)} D_{j,1-M_{j,i}}(S, Y), \max_{k \in s_s(i)} D_{k,1-(B_{i,k}-M_{i,k})}(S, Y) \right), \quad (9)$$

$$D_{i,n}(S, Y) = \sigma_{i,n} + \max \left( D_{i,n-1}(S, Y), \max_{j \in p_s(i)} D_{j,n-M_{j,i}}(S, Y), \max_{k \in s_s(i)} D_{k,n-(B_{i,k}-M_{i,k})}(S, Y) \right),$$

$$\forall i \in V, n \geq 2, \quad (10)$$

where, by convention,  $D_{i,n}(S, Y) = 0$ ,  $n \leq 0$ .

**Proof.** One can show these relations by induction on the vertices of  $\mathcal{G}_S$  using the following facts.

- server  $i$  can begin service only after time  $Y_i$ ;
- a server can begin service of the  $n$ -th job if and only if the previous  $n - 1$  jobs have completed, all the preceding buffers are non-empty, and all the succeeding buffers are non-full;
- a server without predecessors in  $G$  is never starved;
- a server without successors in  $G$  is never blocked.

The detailed proof is left to the interested reader. ■

Based on these evolution equations, we can express the departure times in  $\mathcal{S}$  by the lengths of paths in  $\mathcal{G}_{\mathcal{S}}$ . Let  $\mathcal{P}(i, n)$  be the set of all paths that end at node  $(i, n) \in \mathcal{V}$ .

**Lemma 5.5**

$$D_{i,n}(\mathcal{S}, Y) = \max_{P=((i_1, n_1) \rightarrow \dots \rightarrow (i_k, n_k) = (i, n)) \in \mathcal{P}(i, n)} Y_{i_1} + \sum_{h=1}^k \sigma_{i_h, n_h}, \quad \forall i \in V_{\mathcal{S}}, n \geq 1 \quad (11)$$

**Proof.** The proof can be carried out by simple induction on the vertices of  $\mathcal{G}_{\mathcal{S}}$  in using Lemma 5.4. ■

We are now in a position to show the existence of the throughput.

**Theorem 5.6** *Let  $\mathcal{S}$  be an arbitrary deadlock free FJQN/B. Assume that the service times are jointly stationary and ergodic sequences of integrable RV's. Then there exists a constant  $\mu$  such that for all  $Y \in \mathbb{R}^{+n_s}$ ,*

$$\mu = \lim_{n \rightarrow \infty} \frac{D_n(\mathcal{S}, Y)}{n} \quad a.s. \quad (12)$$

**Proof.** Let  $\mathcal{P}$  denote the set of all paths in  $\mathcal{G}_{\mathcal{S}}$ . For all  $1 \leq m \leq n$ , define

$$X_{m,n} = \max_{P=((i_1, n_1) \rightarrow \dots \rightarrow (i_k, n_k)) \in \mathcal{P}, n_1=m, n_k=n} \sum_{h=1}^k \sigma_{i_h, n_h}$$

It is easy to check that for all  $1 \leq m \leq l < n$ ,

$$X_{m,n} \leq X_{m,l} + X_{l+1,n}$$

Therefore  $X_{m,n}$  is a subadditive process. Since the service times are jointly stationary, the process  $X_{m,n}$  is stationary. Due to the fact that

$$X_{m,n} \leq \sum_{h=m}^n \sum_{i \in V_s} \sigma_{i,h}$$

the integrability of the service times entails that  $X_{m,n}$  is integrable. Using Kingman's theorem on stationary ergodic subadditive processes (c.f. [19]), we obtain

$$\mu = \lim_{n \rightarrow \infty} \frac{X_{1,n}}{n} \quad a.s.. \quad (13)$$



Observe that

$$X_{1,n} \leq D_n(\mathcal{S}, \mathbf{Y}) \leq Z + X_{1,n},$$

where  $Z = \max_{i \in V_s} Y_i$ , we get

$$\mu = \lim_{n \rightarrow \infty} \frac{D_n(\mathcal{S}, \mathbf{Y})}{n} \quad a.s..$$

The proof of the theorem can thus be concluded. ■

**Remarks:**

1. The above theorem shows that, under the stationary and ergodic assumptions, the throughput is independent of the initial timing constraints. The throughput of  $\mathcal{S}$  corresponds to the constant  $\mu$  introduced in the theorem and will be denoted hereafter as  $\theta(\mathcal{S})$ . A similar result was obtained in [3] within the context of SCMG's.

2. The existence of the throughput requires only that the service times form jointly stationary and ergodic sequences of RVs with finite means. No independence of the service times is needed. These assumptions trivially hold for i.i.d. r.v.'s.

**Corollary 5.7** *Let  $\mathcal{S}$  be a FJQN/B. The throughputs associated with each server are identical,  $\theta_i(\mathcal{S}, \mathbf{Y}) = \theta(\mathcal{S}, \mathbf{Y}) = \theta(\mathcal{S})$ ,  $i = 1, \dots, n_s$ .*

**Proof.** This is a consequence of Lemma 4.4 and the last theorem. ■

We now establish that the throughput of a FJQN/B is independent of the initial markings provided these initial markings are equivalent (cf. Definition 4.2).

**Theorem 5.8** *Let  $\mathcal{N} = (V_s, E, B)$  and let  $\mathcal{S}^1 = (\mathcal{N}, M^1)$  and  $\mathcal{S}^2 = (\mathcal{N}, M^2)$  be two FJQN/B's. If  $M^1 \sim M^2$ , then under the assumptions of theorem 5.6 and the further assumption that the sequences of service times at different servers are mutually independent, the throughput of these two networks are identical:*

$$\theta(\mathcal{S}^1) = \theta(\mathcal{S}^2).$$

**Proof.** Owing to Theorem 4.5, in freezing any server  $i$  in  $\mathcal{N}$ ,  $\mathcal{S}^1$  and  $\mathcal{S}^2$  reach the same state  $M$ . Let  $\mathcal{S} = (\mathcal{N}, M)$  be another FJQN/B which differs from  $\mathcal{S}^1$  and  $\mathcal{S}^2$  only in initial markings. We are going to prove that

$$\theta(\mathcal{S}^1) = \theta(\mathcal{S}) = \theta(\mathcal{S}^2).$$

For this, denote by  $k_j$ ,  $j \in V_s$ , the number of times the server  $j$  has served in  $S^1$  to reach the final state  $M$  when the server  $i$  is frozen ( $k_i = 0$ ). Define the vector  $Y$  as follows:

$$Y_i = \sum_{j \in V_s} \sum_{l=1}^{k_j} \sigma_{j,l},$$

and  $Y_j = 0$  for all  $j \neq i$ .

Let  $\mathcal{T}^1 = (S^1, Y)$  and  $\mathcal{T} = (S, 0)$ . The sequences of the service times associated to  $\mathcal{T}^1$  and  $\mathcal{T}$  are referred to as  $\{\sigma_{j,n}^1\}_{n=1}^\infty$ , and  $\{\sigma_{j,n}\}_{n=1}^\infty$ ,  $j \in V_s$ , respectively. Denote by  $m^1(t)$  and  $m(t)$  the markings of  $\mathcal{T}^1$  and  $\mathcal{T}$  at time  $t \geq 0$ , respectively. Using Theorem 4.5 yields that  $m^1(Y_i^-) = m(0)$ .

Since the sequences of the service times are independent and stationary, we can couple the service times in  $S^1$  and  $S$  in the following way:

$$\sigma_{j,n} = \sigma_{j,k_j+n}^1, \quad n \geq 1, \quad j \in V_s.$$

Clearly, the sequences  $\{\sigma_{j,n}\}_{n=1}^\infty$ ,  $j \in V_s$ , defined as above are also independent and stationary. Under such a coupling, one sees that for all  $t > 0$ ,

$$m(t) = m^1(Y_i + t).$$

Therefore, using Theorem 5.6 yields that

$$\theta(S^1) = \theta(S).$$

Analogously, one can prove that

$$\theta(S^2) = \theta(S),$$

which entails that

$$\theta(S^1) = \theta(S^2).$$

■

### Remarks.

1. The above theorem shows that one of the basic assumptions made in [4] for deriving stability conditions for marked graphs holds when the sequences of the service times are mutually independent. However, the service times at each server need not be independent of each other.
2. One can construct simple counterexamples which show that if the sequences of the service times are dependent, the result of Theorem 5.8 does not hold.

## 6 Reversibility in FJQN/B's

In this section we formally define the reverse FJQN/B,  $S^r$ , of a FJQN/B  $S$  and show that when given the same initial marking, they exhibit identical throughput. Throughout this section we will assume that  $S$  is in canonical form. We begin with the definition of the reverse of a FJQN/B.

**Definition 6.1** *The FJQN/B  $S^r$  is the reverse of  $S = (\mathcal{N} = (V_s, E, B), M)$  if it contains the same servers, buffers, buffer sizes, and initial marking as  $S$  but the reverse of all of the edges in  $S$ , i.e.,  $S^r = (\mathcal{N}^r = (V_s, E^r, B^r), M^r)$  where  $E^r = \{(i, j) | (j, i) \in E\}$  and  $M_{i,j}^r = M_{j,i}$  and  $B_{i,j}^r = B_{j,i}$ ,  $(j, i) \in E$ .*

To be more precise, it is necessary to define a new mapping  $\pi^r(i, j) = \pi(j, i)$ ,  $(j, i) \in E$  such that  $M_k^r = M_k$ ,  $k \in V_b$ . Note that  $M^r$  and  $M$  are really the same as are  $B^r$  and  $B$ . However, we introduce different symbols to account for the difference in the direction of the edges in  $S$  and  $S^r$ . Note that the reverse,  $S^r$ , of  $S$  has the same structure as its full dual,  $S^f$ , i.e.,  $\mathcal{N}^r = \mathcal{N}^f$ . They only differ by their initial marking:  $M^r = M$  while  $M^f = B - M$ . Note also that there is a one to one correspondence between cycles/circuits in  $S$  and  $S^r$ . This allows us to establish the following result regarding the deadlock-free properties of  $S$  and  $S^r$ .

**Lemma 6.2** *The FJQN/B  $S$  is deadlock-free iff the reverse FJQN/B  $S^r$  is deadlock-free.*

**Proof.** Let  $C$  be a cycle in  $S$  and let  $C^r$  be the corresponding cycle in  $S^r$ . Let the arbitrary orientation of  $C^r$  be the reverse of that of  $C$ . Then, it is relatively easy to show that  $I_{C^r}^+(M^r) = I_C^+(M)$  and  $I_{C^r}^-(M^r) = I_C^-(M)$ . Since there is a one to one correspondence between cycles in  $S$  and  $S^r$ , each satisfying this relationship, it follows from Theorem 4.3 that  $S$  is deadlock-free iff  $S^r$  is deadlock-free. ■

The main result of this section is

**Theorem 6.3** *Let  $S = (\mathcal{N}, M)$  be an arbitrary deadlock-free FJQN/B, and  $S^r = (\mathcal{N}^r, M)$  be the reverse FJQN/B of  $S$ . If the service times are jointly stationary reversible ergodic sequences of integrable RV's, then*

$$\theta(S) = \theta(S^r) \tag{14}$$

Before proceeding with the proof, we show some preliminary results.

Let  $\mathcal{S}^r = (\mathcal{N}^r = (V_s, E^r, \mathbf{B}^r), M^r)$  be the reverse FJQN/B of  $\mathcal{S} = ((V_s, E, \mathbf{B}), M)$ . Let  $p_s^r(i) = s_s(i)$  and  $s_s^r(i) = p_s(i)$  denote the sets of predecessor and successor servers of server  $i$  in  $\mathcal{N}^r$ , respectively. Denote by  $\sigma_{i,n}^r$  the  $n$ -th service time of server  $i$  in  $\mathcal{S}^r$ . Let  $D_n(\mathcal{S}^r, \mathbf{0}) = \max_{i \in V_s} D_{i,n}(\mathcal{S}^r, \mathbf{0})$ .

It follows from Lemma 5.4 that for all  $i \in V_s$ ,  $n \geq 1$ ,

$$D_{i,n}(\mathcal{S}^r, \mathbf{0}) = \sigma_{i,n}^r + \max \left( D_{i,n-1}(\mathcal{S}^r, \mathbf{0}), \max_{j \in p_s^r(i)} D_{j,n-M_{j,i}^r}(\mathcal{S}^r, \mathbf{0}), \max_{k \in s_s^r(i)} D_{k,n-(B_{i,k}^r - M_{i,k}^r)}(\mathcal{S}^r, \mathbf{0}) \right) \quad (15)$$

where, by convention,  $D_{i,n}(\mathcal{S}^r, \mathbf{0}) = 0$ ,  $n \leq 0$ .

Denote by  $\prec_{\mathcal{S}^r}$  and  $\mathcal{G}_{\mathcal{S}^r} = (\mathcal{V}^r, \mathcal{E}^r)$  the precedence relation and the precedence graph associated with  $\mathcal{S}^r$ , respectively, viz.  $(i, n) \prec_{\mathcal{S}^r} (j, m)$  iff

$$n = m - M_{i,j}^r, \quad i \in p_s^r(j), \quad (16)$$

$$n = m - 1, \quad i = j, \quad (17)$$

$$n = m - (B_{j,i}^r - M_{j,i}^r), \quad i \in s_s^r(j), \quad (18)$$

and

$$\mathcal{V}^r = \{(i, n) \mid n \geq 1, i \in V_s\}$$

$$\mathcal{E}^r = \{(i, n) \rightarrow (m, j) \mid (i, n), (j, m) \in \mathcal{V}^r, (i, n) \prec_{\mathcal{S}^r} (j, m)\}$$

It follows from the fact that  $\mathcal{S}$  is deadlock-free and Lemmas 5.3 and 6.2 that  $\mathcal{G}_{\mathcal{S}^r}$  is acyclic. Let  $\mathcal{P}^r$  be the set of paths of  $\mathcal{G}_{\mathcal{S}^r}$ . Similar to Lemma 5.5, we have

$$D_n(\mathcal{S}^r, \mathbf{0}) = \max_{P^r = ((i_1, n_1) \rightarrow \dots \rightarrow (i_k, n_k)) \in \mathcal{P}^r, n_k = n} \sum_{h=1}^k \sigma_{i_h, n_h}^r, \quad \forall n \geq 1 \quad (19)$$

**Lemma 6.4** For all  $i, j \in V_s$ , and all  $n, m, l \geq 1$ , with  $n > m$ ,  $n > l$ ,

$$(j, l) \prec_{\mathcal{S}} (i, m) \quad \Leftrightarrow \quad (i, n - m) \prec_{\mathcal{S}^r} (j, n - l).$$

**Proof.** Suppose first  $(j, l) \prec_{\mathcal{S}} (i, m)$ . If  $j \in s_s(i)$ , then

$$m - l = B_{i,j} - M_{i,j} = B_{j,i}^r - M_{j,i}^r \quad (20)$$

and  $j \in p_s^r(i)$  so that  $i \in s_s^r(j)$ . Using now (18) together with (20) we obtain that

$$(i, n - m) \prec_{\mathcal{S}^r} (j, n - l).$$

The remainder of the proof can be carried out in an analogous manner. ■

**Lemma 6.5** *Assume that the sequences of the service times are jointly reversible. Then for all  $n \geq 1$ , the service completion times  $D_n(\mathcal{S}, \mathbf{0})$  and  $D_n(\mathcal{S}^r, \mathbf{0})$  have the same distribution.*

**Proof.** For any  $n \geq 1$ , set  $\sigma_{i,m}^r = \sigma_{i,n+1-m}$ ,  $m = 1, 2, \dots, n$ . We rewrite relation (19) as follows

$$\begin{aligned} D_n(\mathcal{S}^r, \mathbf{0}) &= \max_{P^r = ((i_1, n_1) \rightarrow \dots \rightarrow (i_k, n_k)) \in \mathcal{P}^r, n_k = n} \sum_{h=1}^k \sigma_{i_h, n+1-n_h} \\ &= \max_{P^r = ((i_1, n_1) \rightarrow \dots \rightarrow (i_k, n_k)) \in \mathcal{P}^r, n_1 = 1, n_k = n} \sum_{h=1}^k \sigma_{i_h, n+1-n_h}. \end{aligned}$$

An application of Lemma 6.4 yields

$$\begin{aligned} D_n(\mathcal{S}^r, \mathbf{0}) &= \max_{P = ((i_k, n+1-n_k) \rightarrow \dots \rightarrow (i_1, n+1-n_1)) \in \mathcal{P}, n+1-n_k = 1, n+1-n_1 = n} \sum_{h=1}^k \sigma_{i_h, n+1-n_h} \\ &= D_n(\mathcal{S}, \mathbf{0}). \end{aligned} \tag{21}$$

According to the reversibility of the service times, the sequences  $\{\sigma_{i,m}^r\}_{m=1}^n$ ,  $i \in V_s$  have the same joint distribution as  $\{\sigma_{i,m}\}_{m=1}^n$ ,  $i \in V_s$ . Thus

$$D_n(\mathcal{S}^r, \mathbf{0}) =_D D_n(\mathcal{S}, \mathbf{0}), \quad n \geq 1. \tag{22}$$

■

The proof of Theorem 6.3 follows immediately from (21) together with Theorem 5.6.

**Remark.** As the focus of this section was to prove the equality of the throughputs of a FJQN/B and its reverse, it was not necessary to consider initial timing conditions other than  $\mathbf{Y} = \mathbf{0}$ . However, the transient result found in Lemma 6.5 can be shown to hold for an arbitrary initial timing condition.

**Remark.** One can define a *partial reverse* of a FJQN/B  $\mathcal{S}$  where only some of the edges are reversed. However, we have not discovered any interesting properties for this class of FJQN/B's as we have for the full reverse.

## 7 Symmetry Properties

In this section we show that the throughput of a FJQN/B with a given initial marking is identical to the throughput of the same FJQN/B with symmetrical initial marking. This result is obtained by combining the reversibility and duality properties of FJQN/B's.

Consider a FJQN/B  $\mathcal{S} = (\mathcal{N}, \mathbf{M})$  and let  $\mathcal{S}^s = (\mathcal{N}^s, \mathbf{M}^s)$  be the same FJQN/B except that its initial marking is symmetrical to the initial marking of  $\mathcal{S}$ , that is  $\mathcal{N}^s = \mathcal{N}$  and  $\mathbf{M}^s = (\mathbf{B} - \mathbf{M})$ . Note that the initial marking of jobs in  $\mathcal{S}^s$  corresponds to the initial marking of holes in  $\mathcal{S}$  and vice-versa. Now, it is easy to check that  $\mathcal{S}^s$  can be obtained from  $\mathcal{S}$  by applying the reversibility and the duality transformations in any order. That is,  $\mathcal{S}^s$  is the full dual of the reverse of  $\mathcal{S}$  or equivalently  $\mathcal{S}^s$  is the reverse of the full dual of  $\mathcal{S}$ . Then, we have the following results which are readily obtained from the above observation. Actually, Corollary 7.1 follows from Theorem 3.3 and Lemma 6.5, whereas Theorem 7.2 follows from Theorem 3.3, Corollary 3.4, and Theorem 6.3.

**Corollary 7.1** *Assume that the sequences of the service times are jointly reversible. Then for all  $n \geq 1$ , the service completion times  $D_n(\mathcal{S}^s, \mathbf{0})$  and  $D_n(\mathcal{S}, \mathbf{0})$  have the same distribution.*

**Theorem 7.2** *If the service times are jointly stationary reversible ergodic sequences of integrable RV's, then the throughput of a FJQN/B with initial marking  $\mathbf{B} - \mathbf{M}$  is the same as with initial marking  $\mathbf{M}$ , i.e. :*

$$\theta(\mathcal{S}^s) = \theta(\mathcal{S}) \quad (23)$$

**Remark.** It should be noticed that the equivalence between  $\mathcal{S}$  and  $\mathcal{S}^s$  is only in terms of the throughput since the reverse transformation only preserves the throughput.

When Theorem 7.2 is applied to some particular classes of FJQN/B, various results of practical interest can be obtained. In order to illustrate this, let us first consider the case of a closed tandem queueing network  $\mathcal{N}$  (see Figure 3). Such a network consists of exactly one circuit, say  $C$ . Let  $N = I_C^+(\mathbf{M})$  be the invariant of this circuit. We have  $N = \sum M_k$  which is often referred to as the population of the network. Let  $B$  be the total buffer capacity of  $\mathcal{N}$ , that is the sum of the capacities of all the buffers. We have  $B = \sum B_k$ . Then, from Theorems 5.8 and 7.2 we get :

$$\theta(\mathcal{N}, B - N) = \theta(\mathcal{N}, N) \quad (24)$$

That is, the throughput of the network with population  $B - N$  is the same as with population  $N$ , for any  $0 < N < B$ . This result was conjectured by Onvural and Perros [25] for exponentially distributed service times, and first proved by Dallery and Towsley [11] under the assumption that service times are characterized by phase type distributions.

This last result can be generalized considerably, especially to closed networks with series parallel fork-join mechanisms. However, some restrictions must be made so that the symmetry property of Theorem 7.2 can be interpreted in terms of a symmetry with respect to the population of the network. So, let us consider a closed series-parallel fork-join network. Let  $N$  be the population of the network and let  $\mathbf{M}$  be any initial marking consistent with this population of customers.

Then, it is easy to check that this marking is such that the invariants of all the circuits are equal to the population of the network, i.e.,  $I_C^+(M) = N$  for all  $C$ . Now, let us consider the symmetrical initial marking  $B - M$ . The corresponding invariant of circuit  $C$  is  $I_C^+(B - M)$ . Now, we have :

$$I_C^+(B - M) = I_C^-(M) = B_C - I_C^+(M) = B_C - N$$

For this symmetrical marking to be consistent with a population of the network, all the quantities  $I_C^+(B - M)$  must be identical. This is true if and only if all the quantities  $B_C$  are identical, i.e.,  $B_C = B$ , for all  $C$ . In this case, the corresponding population is  $B - N$ . So from Theorem 7.2, we have :

**Corollary 7.3** *If the service times are jointly stationary reversible ergodic sequences of integrable RV's, then the throughput of a closed series-parallel fork-join network with population  $N$  is the same as with population  $B - N$  provided that  $B_C = B$  for all circuits  $C$ .*

For the network of Figure 4, it is easy to check that the condition in Corollary 7.3 is satisfied iff  $B_2 + B_3 = B_4 + B_5 + B_6$  and  $B_9 + B_{10} = B_{11} + B_{12} = B_{13} + B_{14}$ .

Closed series-parallel fork-join networks are just an example of the applicability of the symmetry property. There are other FJQN/B's for which Theorem 7.2 can be interpreted as a symmetry property with respect to populations of customers.

## 8 Extensions and Applications

In this section, we briefly discuss several extensions and applications of the results presented in this paper.

### 8.1 Infinite buffers

Throughout the paper, we assumed that all buffers have finite capacity. It is however possible to handle certain FJQN/B's with infinite buffers provided that they can be transformed into FJQN/B's with all buffers having finite capacity. Let us first establish the following result.

**Lemma 8.1** *Consider a FJQN/B having some infinite buffers. Consider any infinite buffer  $k$  that is part of a cycle  $C$ . Define an orientation of the cycle according to the direction of the flow of jobs through this buffer. Then, if all of the buffers oriented in the reverse direction have finite capacity, this infinite buffer can equivalently be replaced by a finite buffer with capacity set equal to the invariant of the cycle, i.e. :  $B_k = I_C^+(M)$ .*

**Proof.** Since all buffers in the reverse direction have finite buffers, it is easy to check that equation (4) still holds and that the quantity  $I_C^+(M)$  is finite. Now, equation (4) implies that the number of jobs in buffer  $k$  at any time,  $m_k(t)$ , is bounded by  $I_C^+(M)$ . Thus, the buffer  $k$  can be replaced by a buffer of finite capacity  $I_C^+(M)$  without modifying the behavior of the network. ■

Consider a FJQN/B with a subset of buffers having infinite capacity. The transformation described in lemma 8.1 can be applied repeatedly to any infinite buffer that is part of a cycle such that all buffers in the reverse direction have finite buffers. We note that an infinite buffer that did not originally satisfy the condition in lemma 8.1 may satisfy it after a certain number of transformations on other infinite buffers have been performed. So, this procedure must be applied as long as the resulting FJQN/B has at least one infinite buffer that can be transformed into a finite buffer.

We note that any infinite buffer that is part of a circuit can always be replaced by a finite buffer since in this case the condition in lemma 8.1 is obviously satisfied (there is no buffer in the reverse direction). On the other hand, any infinite buffer that is not part of a cycle can never be replaced by a finite buffer.

A typical example for which this transformation can be performed is a closed tandem queueing network with infinite buffer capacity. Let  $N$  be the population of this network, that is the total number of jobs in the network. The graph of this FJQN/B consists of a single circuit. As a result, all the buffers can be replaced by buffers having a finite capacity  $N$ . More generally, any closed series-parallel fork-join network with infinite buffers can be transformed into a FJQN/B with all finite buffers.

Now, if the final FJQN/B is such that all buffers have finite capacity, all of the results presented in the paper can be applied to it. Some of these results can then be reinterpreted on the original network. It is the case for all the results pertaining to the throughput and reversibility properties that presented in Sections 5 and 6. On the other hand, the symmetry property has no interpretation for the original network since the buffer capacity vector  $B$  of the final FJQN/B is a function of the initial marking  $M$ .

Finally, we note that the behavior of a FJQN/B having infinite buffers that cannot be transformed into finite buffers is more complex. In fact, such FJQN/B's are equivalent to (non-strongly connected) Marked Graphs, so that we are faced with the problem of stability. Results obtained by Baccelli et al. [3,4] can be applied to these FJQN/B's.



## 8.2 Population constraints

Consider a FJQN/B with an initial marking,  $S$ . Now, suppose one would like to add a restriction on the total number of jobs that can be present between a pair of servers, say  $i$  and  $j$ . For sake of simplicity, we assume that there is a single path between these two servers. Let  $B_0$  be the total buffer capacity among all of the buffers on the path between servers  $i$  and  $j$ . Server  $i$  is prevented from working if the total number of jobs between  $i$  and  $j$  is equal to a given value, say  $P$ , with  $P < B_0$ . This population constraint can easily be modeled by adding a buffer between server  $i$  and server  $j$  having a capacity  $B_{i,j} = P$ . The initial marking of this buffer is equal to the sum of the initial markings of the buffers between server  $i$  and server  $j$ . Let  $S'$  denote the resulting FJQN/B.

Consider the reversibility property. Let  $S^r$  be the reverse of  $S$ . Let  $S^{r'}$  be the network obtained from  $S^r$  by adding a population constraint of size  $P$  between server  $j$  and server  $i$  in the same way as for  $S$ . Now, it is easy to check that  $S^{r'}$  is the reverse of  $S'$  and as a result they have the same throughput. So,  $S^r$  with a population constraint in between servers  $j$  and  $i$  has the same throughput as  $S$  with the same population constraint between servers  $i$  and  $j$ . Thus, reversibility holds for FJQN/B's with population constraints.

Consider now the symmetry property. Let  $S^s$  be the symmetrical network of  $S$ . Let  $S^{s'}$  be the network obtained from  $S^s$  by adding the population constraint of size  $P$  between server  $i$  and server  $j$  in the same way as for  $S$ . Now, one can check that  $S^{s'}$  is not the symmetrical network of  $S'$  and as a result they do not have the same throughput. So,  $S$  with a population constraint of size  $P$  between servers  $i$  and  $j$  does not have the same throughput as  $S^s$  with the same population constraint. Thus, symmetry does not hold for FJQN/B's with population constraints.

## 8.3 Multiple servers

All of the results presented in the paper hold for single servers. Let us now briefly discuss the case of multiple servers. First, it is easy to check that the results pertaining to equivalence and qualitative properties (Sections 3 and 4) hold in the case of multiple servers. Especially, a FJQN/B with multiple servers has the same behavior as any of its dual. This again follows from the job/hole duality. It should however be emphasized that duality holds under the convention that there is no space on the servers, that is the capacity of the buffers includes the server spaces.

On the other hand, the results pertaining to the throughput cannot easily be extended to multiple servers. The reason is that the results presented in Section 5 were based on the fact that the behavior of the network can be described by  $(\max,+)$  equations (see Lemma 5.4). This

is no longer true in the case of multiple servers. More important, the reversibility property does not hold for multiple servers, in general. The problem we are faced with is that overtaking may occur. This fact was already pointed out in the case of tandem queueing networks with blocking after service in [31].

There is, however, an important case for which overtaking cannot occur. It is when all multiple servers have deterministic service times. So, in that case, all of the results presented in this paper, especially reversibility and symmetry, still hold.

## 8.4 Unreliable servers

Let us finally consider the case of unreliable servers. For the sake of simplicity, we restrict our attention to the case where for each server, the service times, the times to failures (up time) and the times to repair (down time) are i.i.d. random variables. Also, we assume that failures are operation dependent, that is a failure can occur only when the server is working. Whenever the server is idle (starved or blocked), the failure process is stopped. In this case, the service period of a server corresponds to the so-called *completion time* [15,24], that is the total time between the beginning and the completion of the operation. This time is the sum of the service time and the repair times corresponding to the failures that occur during the processing, if any. Suppose now that the time to failure is exponentially distributed. In this case, it can be shown (see e.g. [24]) that the resulting service period are i.i.d. random variables. Thus, all the results presented in the paper can still be applied.

## 9 Conclusions

In this paper, we have shown various quantitative as well as qualitative properties of the Fork/Join Queueing Networks with Blocking (FJQN/B's). The blocking mechanism analyzed throughout the paper was the so-called blocking before service. This class of queueing networks is in fact equivalent to the class of strongly connected marked graph in the sense that they can be simulated each other.

We have established the one to one correspondence between the marking distributions of a FJQN/B and of its duals, both in transient state and in steady state. We have also proved the existence of asymptotic throughput and its independence on the initial marking configuration. We have further shown that the reverse of a FJQN/B has the same throughput as the original network. Last, by combining the equivalence results for duals and the reversibility results, we have derived the symmetry property for FJQN/B's. The results obtained in the paper hold under fairly general statistical assumptions, and hold, in particular, when the service times are i.i.d. random variables.

Future research topics include investigating the applications of the reversibility of FJQN/B to queueing networks with blocking after service [12], as well as extending the the FJQN/B model by allowing random routing.

## Appendix: A Proof of Theorem 4.5

Without any loss of generality, we assume that the FJQN/B under consideration is in its canonical form. It is clear that when a server  $i$  is frozen, all other servers will be blocked, starved, or both, after a bounded number of service periods. Let  $m^1$  and  $m^2$  denote the markings of  $\mathcal{S}_1$  and  $\mathcal{S}_2$ , respectively, when such a situation occurs. We will prove  $m^1 = m^2$  by contradiction.

We shall refer to the components of  $m^j$  as  $m_{l_1, l_2}^j$ ,  $j = 1, 2$  and  $(l_1, l_2) \in E$ . Assume that  $m^1 \neq m^2$ . Then there exists at least one buffer  $(j, k) \in E$  such that  $m_{j, k}^1 \neq m_{j, k}^2$  and there is either a chain  $i_1 = i, i_2, \dots, i_{l_0-1} = j, i_{l_0} = k$  or  $i_1 = i, i_2, \dots, i_{l_0-1} = k, i_{l_0} = j$  where all of the buffers on the chain, except  $(j, k)$  have the same markings in both  $m^1$  and  $m^2$ . We will assume that the chain is  $i_1 = i, i_2, \dots, i_{l_0-1} = j, i_{l_0} = k$ . The other chain can be treated in a similar way. There are two cases depending on whether  $(j, k)$  is part of a cycle or not.

*i)  $(j, k)$  is not part of a cycle.* In this case, it is not difficult to show that  $m_{j, k}^1 = m_{j, k}^2 = 0$  which contradicts the assumption that  $m_{j, k}^1$  differs from  $m_{j, k}^2$ .

*ii)  $(j, k)$  is part of a cycle.* Without loss of generality, we assume that  $m_{j, k}^1 > m_{j, k}^2 \geq 0$ . Beginning with the chain  $i_1, \dots, i_{l_0}$ , the following algorithm constructs a chain  $P$  that contains a cycle  $C$  in  $\mathcal{N}$  which will either be deadlocked or have a different invariant measure in  $\mathcal{S}_1$  than  $\mathcal{S}_2$ . Both of these contradict the assumptions made in the theorem.

### Algorithm:

1. initialize  
 $direction := downstream; P := \{i_1, \dots, i_{l_0}, \}; r = l_0;$
2. main body of algorithm.  
 if  $direction = downstream$  then  
     if there exists  $n \in s_s(i_r)$  such that  $m_{i_r, n}^1 = B_{i_r, n}$   
         then choose  $n$  to be part of the chain  $P$ ;  
         else  $direction := upstream; go to 2;$   
 else

if there exists  $n \in p_s(i_r)$  such that  $m_{n,i_r}^1 = 0$   
 then choose  $n$  to be part of the chain  $P$ ;  
 else *direction* := *downstream*; go to 2;  
 if  $n = i_l \in P$  then return  $C = (i_l, i_{l+1}, \dots, i_r)$  and stop;  
 else  $r := r + 1$ ;  $i_r := n$ ;  $P := P + \{i_r\}$ ;  
 go to 2.

First, we show that this algorithm will terminate. Consider any server  $a \in V_s$ ,  $a \neq i$ , that is contained within one or more cycles. According to the assumption of the theorem it is either starved, blocked, or both. Hence, either  $p_b(a)$  contains a buffer that is empty or  $s_b(a)$  contains at least one full buffer, or both. Hence, whenever we examine the last server on chain  $P$ ,  $i_r$ , we will always find either a server  $n \in s_s(i_r)$  such that buffer  $(i_r, n)$  is full or a server  $n \in p_s(i_r)$  such that buffer  $(n, i_r)$  is empty. Consequently, the algorithm always identifies a new server during each execution of 2. Clearly the algorithm will terminate as  $V_s$  contains a finite number of servers.

It should be clear from the behavior of the algorithm that it never returns  $C = (i_{r-1}, i_r)$ . This is because whenever  $(i_{r-1}, i_r) \in E$ , then  $m_{i_{r-1}, i_r}^1 > 0$  and whenever  $(i_r, i_{r-1}) \in E$ , then  $m_{i_r, i_{r-1}}^1 = 0$ . Consequently,  $i_{r-1}$  can never be a candidate for the next server on the chain after  $i_r$ .

This algorithm produces a cycle that is in one of two forms depending on the position of  $i_l$  with respect to  $i_0$ . If  $l \geq l_0$ , then we claim that the algorithm produces a cycle in which all of the buffers oriented in one direction are empty and all of the buffers oriented in the opposite direction are full. Consequently  $\mathcal{N}_1$  in conjunction with marking  $m^1$  is deadlocked. This contradicts the assumption that  $\mathcal{S}_1$  was deadlock free.

Consider the case that  $l < l_0$ . Orient the cycle so that  $(i_{l_0-1}, i_{l_0})$  is pointed upstream within the cycle. The buffers in the cycle divide into five groups,  $V_0$  contains  $(i_{l_0-1}, i_{l_0})$ ,  $V_1$  contains all of the buffers in the cycle between server  $i_l$  and server  $i_{l_0-1}$  with the same orientation as  $(i_{l_0-1}, i_{l_0})$  within the cycle,  $V_2$  contains all of the buffers in the cycle between server  $i_l$  and server  $i_{l_0-1}$  with orientations opposite to  $(i_{l_0-1}, i_{l_0})$  within the cycle,  $V_3$  contains all of the remaining buffers with the same orientation as  $(i_{l_0-1}, i_{l_0})$  not in  $V_0 + V_1$ , and  $V_4$  contains all of the buffers not in  $V_2$  that have an orientation opposite to that of  $(i_{l_0-1}, i_{l_0})$ . Now the invariant for this cycle is

$$\begin{aligned}
 I_C^+(m_1) &= m_{j,k}^1 + \sum_{b \in V_1} m_b^1 + \sum_{b \in V_2} (B_b - m_b^1) + \sum_{b \in V_3} B_b + \sum_{b \in V_4} B_b, \\
 &\geq m_{j,k}^1 + \sum_{b \in V_1} m_b^1 + \sum_{b \in V_2} (B_b - m_b^1) + \sum_{b \in V_3} m_b^2 + \sum_{b \in V_4} (B_b - m_b^2),
 \end{aligned}$$

$$\begin{aligned}
&> m_{j,k}^2 + \sum_{b \in V_1} m_b^1 + \sum_{b \in V_2} (B_b - m_b^1) + \sum_{b \in V_3} m_b^2 + \sum_{b \in V_4} (B_b - m_b^2), \\
&= I_C^+(m_2).
\end{aligned}$$

Consequently  $m_1 \not\sim m_2$  which can only occur if  $M_1 \not\sim M_2$  which contradicts the statement of the theorem. ■

**Acknowledgment.** The authors are grateful to F. Bonheure for useful discussions at the beginning of this work.

## References

- [1] M. H. Ammar, S. B. Gershwin. "Equivalence Relations in Queuing Models of Fork/Join Queueing Networks with Blocking", *Performance Evaluation* 10, pp. 233-245, 1989.
- [2] G. R. Andrews, F. B. Schneider. "Concepts and Notations for Concurrent Programming", *ACM Computing Surveys*, 15, 3-43, March 1983.
- [3] F. Baccelli. "Ergodic Theory of Stochastic Petri Networks", INRIA Rapport de Recherche 1037, May 1989. To appear in *The Annals of Probability*.
- [4] F. Baccelli, N. Bambos, J. Walrand. "Flow Analysis of Stochastic Marked Graphs", *Proc. IEEE Conference on Decision and Control*, 1989.
- [5] F. Baccelli, Z. Liu. "On a Class of Stochastic Recursive Sequences Arising In Queueing Theory", To appear in *The Annals of Probability*.
- [6] F. Baccelli and A. Makowski. "Queueing models for systems with synchronization constraints", *Proc. IEEE*, 77, 138-161, Jan. 1989.
- [7] F. Baccelli, W. Massey and D. Towsley. "Acyclic Fork-Join queuing networks", *J. ACM* 36, 3, 615-642, 1989.
- [8] A. Bhargava, J. F. Kurose, D. Towsley, G. VanLeemput. "Performance comparison of error control schemes in high speed computer communication networks", *IEEE Journal on Selected Areas in Communications*, 6, 9, 1565-1575, December 1988.
- [9] P. Caseau, G. Pujolle. "Throughput Capacity of a Sequence of Queues with Blocking due to Finite Waiting Room", *IEEE Trans. on Software Engineering*, 5, 631-642, 1979.
- [10] F. Commoner, A. W. Holt, S. Even, A. Pnuelly. "Marked Directed Graphs", *J. Computer and System Science*, 5, 511-523, 1971.

- [11] Y. Dallery, D. Towsley. "Symmetry Property of the Throughput in Closed Tandem Queueing Networks with Finite Buffers", Tech. Report MASI, No. 90-23, May 1990.
- [12] Y. Dallery, Z. Liu, D. Towsley. "Reversibility in Fork/Join Queueing Networks with Blocking After Service", in preparation.
- [13] M. Di Mascolo, R. David, Y. Dallery. "Modeling and Analysis of Assembly Systems with Unreliable Machines and Finite Buffers", to appear in *IIE Transactions*, March 1991.
- [14] S. Fdida, H. G. Perros, A. Wilk. "Semaphore Queues: Modelling Multilayered Window Flow Control Mechanisms", *IEEE Trans. Communications*, **38**, 3, 309-317, 1990.
- [15] D. P. Gaver. "A Waiting Line with Interrupted Service, Including Priorities", *J.R. Stat. Soc., Ser. B*, **24**, 73-90, 1962.
- [16] S. B. Gershwin. "Assembly/Disassembly Systems: an Efficient Decomposition Algorithm for Tree-Structured Network", MIT Lab. for Manufacturing and Productivity Report, LMP-88-007, June 1988, revised Sept. 1989.
- [17] W. J. Gordon, G. F. Newell. "Cyclic Queueing Systems with Restricted Length Queues", *Operations Research*, **15**, 266-278, 1967.
- [18] C. A. R. Hoare. "Communicating Sequential Processes", *Comm. ACM*, **21**, 666-677, Aug. 1978.
- [19] J. F. C. Kingman. "The Ergodic Theory of Subadditive Processes", *J. Royal Statist. Soc. Ser. B*, **30**, 499-510, 1968.
- [20] B. Melamed. "A Note on the Reversibility and Duality of some Tandem Blocking Queueing Systems", *Management Science*, **32**, 12, 1648-1650, 1986.
- [21] E. G. Muth. "The Reversibility Property of Production Lines", *Management Science*, **25**, 2, 152-158, 1979.
- [22] R. Nelson, A. N. Tantawi. "Approximate Analysis of Fork/Join Synchronization in Parallel Queues", *IEEE Trans. on Computers*, **C-37**, 739-743, 1988.
- [23] M. Neuts. *Matrix-Geometric Solutions in Stochastic Models*. Johns Hopkins, Baltimore, Md. 1981.
- [24] V. F. Nicola. "A Single Server Queue with Mixed Types of Interruptions", *Acta Informatica*, **23**, 465-486, 1986.
- [25] R. O. Onvural, H. G. Perros. "Throughput Analysis of Cyclic Queueing Networks with Finite Buffers", Tech. Report, CS Dept. 87-03, NCSU, Raleigh NC, 1987.

- [26] J. L. Peterson. *Petri Net Theory and the Modeling of Systems*, Prentice Hall, 1981.
- [27] H. G. Perros, "Approximation Algorithms for Open Queueing Networks with Blocking", *Stochastic Analysis of Computer and Communication Systems*, (ed. H. Takagi), North-Holland, Amsterdam, Netherlands, 1989.
- [28] I. C. Pyle. *The Ada Programming Language*. Prentice-Hall International, London, 1981.
- [29] B. A. Sevast'yanov. "Influence of Storage Bin Capacity on the Average Standstill Time of a Production Line", *Theory of Probability and its Applications*, 7, 4, 429-438, 1962.
- [30] J. Walrand. *An Introduction to Queueing Networks*, Prentice Hall, 1988.
- [31] G. Yamazaki, T. Kawashiha, H. Sakasegawa. "Reversibility of Tandem Blocking Queueing Systems", *Management Science*, 31, 1, 78-83, 1985.

**ISSN 0249-6399**