



HAL
open science

Taylor Expansions for Poisson Driven $(\max, +)$ -Linear Systems

François Baccelli, Volker Schmidt

► **To cite this version:**

François Baccelli, Volker Schmidt. Taylor Expansions for Poisson Driven $(\max, +)$ -Linear Systems. RR-2494, INRIA. 1995. inria-00074181

HAL Id: inria-00074181

<https://inria.hal.science/inria-00074181>

Submitted on 24 May 2006

HAL is a multi-disciplinary open access archive for the deposit and dissemination of scientific research documents, whether they are published or not. The documents may come from teaching and research institutions in France or abroad, or from public or private research centers.

L'archive ouverte pluridisciplinaire **HAL**, est destinée au dépôt et à la diffusion de documents scientifiques de niveau recherche, publiés ou non, émanant des établissements d'enseignement et de recherche français ou étrangers, des laboratoires publics ou privés.

Taylor Expansions for Poisson Driven $(\max, +)$ -Linear Systems

François Baccelli Volker Schmidt

N° 2494

Février 1995

PROGRAMME 1

*Rapport
de recherche*

Taylor Expansions for Poisson Driven (max, +)-Linear Systems

François Baccelli * Volker Schmidt **

Programme 1 — Architectures parallèles, bases de données, réseaux et systèmes distribués

Projet Mistral

Rapport de recherche n° 2494 — Février 1995 — 50 pages

Abstract: We give a Taylor expansion for the mean value of the canonical stationary state variables $\{W_n\} = \{X_n - T_n\}$ of open (max, +)-linear stochastic systems with Poisson input process, that is systems with (transient) state variables $\{X_n\}$ satisfying the vectorial recursion $X_{n+1} = A_n X_n \oplus B_{n+1} T_{n+1}$ in this algebra, where $\{T_n\}$ is a Poisson point process, and $\{A_n\}$ and $\{B_n\}$ are sequences of random matrices satisfying certain independence properties.

Probabilistic expressions are derived for coefficients of all orders, under certain integrability conditions: the k -th coefficient in the Taylor expansion of the i -th component $\mathbb{E}W_n^i$ of $\mathbb{E}W_n$ is the expectation of a polynomial $p_{k+1}(D_0^i, \dots, D_k^i)$, known in explicit form, of the random variables D_0^i, \dots, D_k^i , where $D_n^i = (A_{-1} \dots A_{-n} B_{-n})^i$. The polynomials $\{p_k\}$ are of independent combinatorial interest: their monomials belong to a subset of those obtained in the multinomial expansion; they are also invariant by cyclic permutation and by translations along the main diagonal.

The method for proving these results is based on two ingredients: a) the (max, +)-linear representation of the stationary state variables as functionals of the input point process; b) the Taylor expansion representation of functionals of marked point processes, and in particular of Poisson point processes.

Several applications of these results are proposed within the framework of stochastic Petri nets. It is well known that (max, +)-linear systems allow one to represent stochastic Petri nets belonging to the class of event graphs. This class contains various instances of queueing networks like acyclic or cyclic fork-join queueing networks, finite or infinite capacity tandem queueing networks with various types of blocking (manufacturing and communication), synchronized queueing networks etc. It also contains some basic manufacturing models such as Kanban networks, Job-Shop systems etc. The applicability of this expansion method is discussed for several systems of this type. In the M/D case (i.e. all service times are deterministic), the approach is quite practical, as all coefficients of the expansion are obtained in closed form. In the M/GI case, the computation of the coefficient of order k can be seen as that of joint distributions in a stochastic PERT graph of an order which is linear in k , a problem for which no polynomial algorithms are apparently known. We nevertheless show that expansions of limited order can be obtained in explicit form along these lines.

Key-words: Stochastic Petri net, point process, stationary regime, Pollaczek-Khinchine formula, M/GI-type queues, response time.

(Résumé : *tsvp*)

*INRIA-Sophia Antipolis (France), {Francois.Baccelli}@sophia.inria.fr; the work of this author was supported by the PROCOPE project the ESPRIT 3 BRA Qmips project.

**University of Ulm (Germany), {Volker.Schmidt}@mathematik.uni-ulm.de; the work of this author was supported by the PROCOPE project.

Développements de Taylor pour les systèmes $(\max, +)$ -linéaires avec des entrées de Poisson

Résumé : Nous donnons un développement de Taylor des valeurs moyennes des variables d'état canoniques $\{W_n\} = \{X_n - T_n\}$ d'un système stochastique $(\max, +)$ -linéaire ouvert avec des entrées formant un processus ponctuel de Poisson, c'est à dire d'un système de variables d'état $\{X_n\}$ satisfaisant les équations de récurrence vectorielles $X_{n+1} = A_n X_n \oplus B_{n+1} T_{n+1}$ dans cette algèbre, où $\{T_n\}$ est un processus de Poisson, et $\{A_n\}$ et $\{B_n\}$ sont des suites de matrices aléatoires vérifiant certaines propriétés d'indépendance.

Nous obtenons des expressions probabilistes pour les coefficients de tous ordres sous certaines conditions d'intégrabilité: le coefficient d'ordre k du développement de Taylor de la i ème coordonnée $\mathbb{E}W_n^i$ de $\mathbb{E}W_n$ est donné comme l'espérance d'un polynôme $p_{k+1}(D_0^i, \dots, D_k^i)$, dont on a une forme explicite, où $D_n^i = (A_{-1} \dots A_{-n} B_{-n})^i$. Les polynômes $\{p_k\}$ ont d'intéressantes propriétés combinatoires: leurs monômes appartiennent à un sous-ensemble des monômes du développement multinomial. Ils sont aussi invariants par permutation circulaire et par translation le long de la diagonale principale.

Les outils mathématiques qui sous-tendent ce résultat sont de deux ordres: a) la représentation $(\max, +)$ -linéaire des variables d'état stationnaires sous forme de fonctionnelles d'un processus ponctuel; b) le développement de Taylor de fonctionnelles de processus ponctuels, et en particulier de processus de Poisson.

Nous proposons plusieurs applications de ces résultats à l'analyse quantitative de réseaux de Petri stochastiques. Il est bien connu que les systèmes $(\max, +)$ -linéaires correspondent à la classe des graphes d'événements. Cette classe contient plusieurs exemples de réseaux de files d'attente comme les réseaux avec fission-fusion, cycliques ou acycliques, les réseaux de files d'attente en série avec capacité finie ou non, et divers types de mécanismes de blocage, les réseaux synchronisés etc. Elle contient aussi certains modèles de base de productique comme les réseaux de type Kanban. Nous montrons en détail comment appliquer cette méthode sur plusieurs exemples de ce type.

Dans le cas M/D (tous les services sont déterministes), l'approche proposée donne des coefficients de tous ordres sous forme explicite. Dans le cas M/GI , le calcul du coefficient d'ordre k peut être vu comme le calcul des caractéristiques d'un graphe PERT dont la taille est linéaire en k , un problème pour lequel on ne connaît apparemment pas d'algorithme polynomial. Nous montrons néanmoins que des développements d'ordres limités peuvent être calculés de manière explicite.

Mots-clé : Réseau de Petri stochastique, processus ponctuel, régime stationnaire, formule de Pollaczek-Khinchine, file d'attente de type M/GI , temps de réponse.

1 Introduction

Under the notion of an open $(\max, +)$ -linear stochastic system one understands a sequence $\{X_n\}$ of random vectors satisfying the recursion $X_{n+1} = A_n \otimes X_n \oplus B_{n+1} \otimes T_{n+1}$ where the addition \oplus means taking the maximum and multiplication \otimes means $+$. $\{T_n\}$ is an increasing sequence of real-valued random variables, and $\{A_n\}$ and $\{B_n\}$ are stationary sequences of random matrices. Such systems allow one to represent the dynamics of stochastic Petri nets belonging to the class of event graphs (see [2, 6]). In particular, this class contains various instances of queueing networks like acyclic or cyclic fork-join queueing networks, finite or infinite capacity tandem queueing networks with various types of blocking (manufacturing and communication), synchronized queueing networks etc. It also contains some basic manufacturing models such as Kanban networks, Job-Shop systems etc. In all these models, T_n is the arrival epoch of the n -th customer in the network and the coordinates X_n^i of the state vector $X_n = (X_n^1, \dots, X_n^\alpha)$ represent absolute times (like the beginning of the n -th service in the i -th queue) which grow to infinity when n increases unboundedly. For this reason, one is actually more interested in the differences $W_n^i = X_n^i - T_n$ (like the waiting time of the n -th customer until the beginning of his service in queue i), which are expected to admit a stationary state $W^i = \lim_{n \rightarrow \infty} W_n^i$ under certain rate conditions. Unfortunately, in many cases it is impossible to determine characteristics of the random vector $W = (W^1, \dots, W^\alpha)$ in closed form. Even for the expectation vector $\mathbb{E}W = (\mathbb{E}W^1, \dots, \mathbb{E}W^\alpha)$, analytical formulas are known only for a small number of rather specific models, see e.g. [15]. This unsatisfactory situation motivated our research to derive a method which makes it possible to determine an expansion for $\mathbb{E}W$.

Assuming that $\{T_n\}$ is a homogeneous Poisson process with intensity λ and that the sequences $\{A_n\}$ and $\{B_n\}$ have certain independence properties, we derive a Taylor expansion for $\mathbb{E}W$ with respect to the arrival intensity λ , where we use a general method which consists in expanding the expectation of a vector-valued functional of a marked point process. For univariate (non-marked) point processes, this concept has been developed in [9] starting from a corresponding first-order expansion obtained in [3]. Related higher-order expansions for functionals of independently marked Poisson processes have been considered in [20, 26, 29], and for more general marked point processes in [10, 12], see also the survey given in [13].

Under certain monotonicity and integrability conditions on $\{A_n, B_n\}$, we derive a probabilistic expression for the coefficients c_k^i of all orders k of the expansion

$$\mathbb{E}W^i = \sum_{k=0}^m c_k^i \lambda^k + \mathcal{O}(\lambda^{m+1}).$$

Namely, we show that $c_k^i = \mathbb{E}p_{k+1}(D_0^i, D_1^i, \dots, D_k^i)$ where D_n^i is the i -th component of the random vector $D_n = A_{-1} \otimes \dots \otimes A_{-n} \otimes B_{-n}$. The mappings $p_k : \mathbb{R}^k \rightarrow \mathbb{R}$ are polynomials which are determined explicitly. They are of independent combinatorial interest. Their monomials belong to a subset of those obtained in the multinomial expansion; they are also invariant by cyclic permutation and by translation along the main diagonal.

The idea of deriving Taylor expansions for characteristics of continuous time Markov chains is not new. We have extended this approach to non-Markov systems by using techniques originating in the theory of perturbation of point processes. The expansion method considered in the present paper and in [3, 9, 10, 12, 13, 20, 26, 29] is based on the integration of certain kernels over factorial moment measures of the underlying point process. An important feature of this new approach is that its application is not limited to systems with only one or two unbounded coordinates (like for instance complex-variable techniques, which are essentially limited to two unbounded coordinates). Future research will bear on the extension of this computational point-process approach to the derivation of expansions for Laplace transforms and higher moments, and eventually to the case of networks with non-Poisson input processes.

One can find several other earlier attempts to approximate characteristics of queueing systems by expanding them into a series, see e.g. [7, 8, 22, 23, 24, 30, 32]. The main features of our new approach based on factorial-moment expansions are the following:

- it applies to multidimensional M/GI type models, whereas earlier approaches apply essentially to the M/M case;
- it applies to a class of systems ((max, +)-linear systems) which is defined via its structural properties, and not via properties of its Markovian generator.

Besides some cases of small dimension, which were shown to be analyzable via Markovian techniques ([28]), the only case in which the stationary (or more precisely the periodic) regime of such multidimensional (max, +)-linear systems is known in explicit form, seems to be the purely deterministic case ([6, 17, 18]).

The applicability of the derived algorithm to determine an approximation of $\mathbb{E}W$ is discussed for several examples of queueing networks. In the M/D case (i.e. all service times are deterministic), our approach is quite practical as all coefficients of the expansion are obtained in closed form. In the M/GI case, the computation of the coefficient of order k can be seen as that of joint distributions in a stochastic PERT graph of an order which is linear in k , a problem for which no polynomial algorithms are apparently known.

The paper is organized as follows. In Section 2 some preliminaries are given including the basic recurrence equations and the (max, +)-representation of stationary state variables. Section 3 contains the main expansion formula and the conditions under which this algorithm works. General properties of the polynomials p_k appearing in the coefficients of the expansion are stated and the polynomials p_1, p_2, \dots, p_5 up to order 5 are calculated explicitly. In Section 4 we discuss several examples of discrete event systems the state variables of which satisfy the basic recurrence equations, in particular stochastic event graphs such that all places and transitions are FIFO. For practical examples of queueing, communication and manufacturing systems that fall in the class of stochastic event graphs it is demonstrated how expansions of $\mathbb{E}W$ can be found. The general method of factorial-moment expansion is stated in Section 5, together with the proof that it is allowed to use this method for expanding $\mathbb{E}W$. Section 6 is devoted to the calculation of the mappings p_k which appear in the expansion coefficients. First we show that the p_k 's satisfy a recursive integral equation and next we derive an explicit polynomial solution of this equation.

2 Preliminaries

2.1 Basic Equations

The basic reference algebra throughout this paper is the so-called (max, +)-algebra on the real line \mathbb{R} , namely the semi-field with the two operations (\oplus, \otimes) , where \oplus is max and \otimes is +. As in the conventional algebra, \otimes has priority over \oplus in all arithmetic expressions.

Let $\alpha \in \mathbb{N} = \{1, 2, \dots\}$ be any given natural number. The main topic of this paper is the set of α -dimensional vectorial recurrence equations

$$X_{n+1} = A_n \otimes X_n \oplus B_{n+1} \otimes T_{n+1}, \quad (1)$$

with initial condition X_0 , where

- $\{T_n\}$ is a non-decreasing sequence of real-valued random variables (the epochs of the *arrival point process* – a Poisson point process in most examples below);
- $\{A_n\}$ is a sequence of $\alpha \times \alpha$ random matrices with real-valued random entries;
- $\{B_n\}$ is a sequence of $\alpha \times 1$ random matrices with real-valued random entries;
- $\{X_n\}$ is the sequence of α -dimensional state vectors;

For convenience, we denote the entries of a matrix A by $A_{i,j}$, and the components of an (α -dimensional) column vector X by X^i , i.e. considering X as an $\alpha \times 1$ matrix we have $X_{i,1} = X^i$. As in the conventional algebra, we use the same symbols \oplus, \otimes to represent the sum and the product of two reals and two matrices, respectively. The \otimes -product of two matrices, say A of size $p \times q$ and B of size $q \times r$ is the $p \times r$ matrix $A \otimes B$ with entries

$$(A \otimes B)_{i,j} = \bigoplus_{k=1}^q A_{i,k} \otimes B_{k,j} \quad (2)$$

and the \oplus -sum of two matrices, say A and B both of size $p \times q$ is the $p \times q$ matrix $A \oplus B$ with entries

$$(A \oplus B)_{i,j} = A_{i,j} \oplus B_{i,j}. \quad (3)$$

Various examples of discrete event systems with state variables satisfying an equation of type (1) are provided in Section 4.

In all the applications presented below, the coordinates of the state vector X_n represent absolute times (like the beginning of the n -th service in a queue) which grow to infinity when n increases unboundedly, and one is actually more interested in the differences

$$W_n^i = X_n^i - T_n, \quad (4)$$

(like the waiting time of the n -th customer until the beginning of his service in queue i , see Section 4.2), which are expected to admit a stationary regime under certain rate conditions. Let $\tau_n = T_{n+1} - T_n$, $n \geq 0$. By subtracting T_{n+1} on both sides of (1), it is easily checked that the (new) state vector W_n , given by (4) and being of dimension α as well, satisfies the linear evolution equation

$$W_{n+1} = A_n \otimes C(\tau_n) \otimes W_n \oplus B_{n+1}, \quad (5)$$

where, for all $x \in \mathbb{R}$, $C(x)$ is the $\alpha \times \alpha$ matrix with all diagonal entries equal to $-x$ and all non-diagonal entries equal to $\varepsilon = -\infty$.

Although, in this paper, we will focus on the case when $\sum_n \delta_{T_n}$ is a stationary Poisson process, for the moment let us consider the more general model where $\sum_n \delta_{(T_n, A_n, B_n)}$ is an arbitrary stationary and ergodic marked point process N on the real line, defined on a probability space (Ω, \mathcal{F}, P) , and such that (A_n, B_n) is a *mark* of point T_n . We further assume that (Ω, \mathcal{F}, P) is equipped with a group $\{\theta_t\}_{t \in \mathbb{R}}$ of measurable shift operators $\theta_t : \Omega \rightarrow \Omega$ such that P is invariant with respect to $\{\theta_t\}$ and that N is consistent with $\{\theta_t\}$, i.e. $P \circ \theta_t = P$ and $N \circ \theta_t = N(\cdot + t)$. Moreover, we assume that N is simple, i.e. with probability 1 there are no multiple points, and that N has a positive and finite intensity λ . Point processes on the real line and, in particular, queueing systems with arrival epochs forming a stationary ergodic marked point process were studied in [4, 19, 25]. An important special case of that is the case of a renewal arrival process and an independent (i.i.d. or Markovian) sequence $\{A_n, B_n\}$, which is sometimes referred to as the renewal-Markov case.

Let P^0 denote the Palm probability of N , and θ the discrete (pointwise) shift associated with the continuous-time shifts θ_t . By T_0 we denote the smallest non-negative point of N , i.e. $P^0(T_0 = 0) = 1$ and T_n , $n < 0$ is the n -th point of N on the negative half-line $\mathbb{R}^- = (-\infty, 0)$. Let $A = A_0$ and $B = B_0$; so for all integers n

$$A_n = A \circ \theta^n, \quad B_n = B \circ \theta^n, \quad P^0 \text{ a.s.} \quad (6)$$

Similarly, let $C = C(\tau_0)$, i.e. $C(\tau_n) = C \circ \theta^n$ under P^0 . Note that the sequence $\{A_n, B_n\}$ is stationary both under P and P^0 provided that $\{T_n\}$ and $\{A_n, B_n\}$ are independent.

The following result is proved in Chapter 7 of [6]:

Theorem 1 *Assume that the matrices A_n, B_n are P^0 -integrable. If $\rho < 1$, where $\rho = \lambda a$ and a is the maximal $(\max, +)$ -Lyapunov exponent of the sequence $\{A_n\}$, then the sequence W_n couples P^0 -a.s. with a unique stationary sequence $\{W \circ \theta^n\}$ on $(\Omega, \mathcal{F}, P^0)$, where W is the unique finite random-variable solution of the functional equation*

$$W \circ \theta = A \otimes C \otimes W \oplus B \circ \theta, \quad (7)$$

which is given by the following matrix-series:

$$W = B \oplus \bigoplus_{n \geq 1} A \circ \theta^{-1} \otimes C \circ \theta^{-1} \otimes \dots \otimes A \circ \theta^{-n} \otimes C \circ \theta^{-n} \otimes B \circ \theta^{-n}. \quad (8)$$

Remark Since $C(x)$ commutes with any matrix, W admits the following equivalent representation:

$$W = B_0 \oplus \bigoplus_{n \geq 1} C(-T_{-n}) \otimes D_n \quad (9)$$

where

$$D_n = A_{-1} \otimes \dots \otimes A_{-n} \otimes B_{-n}. \quad (10)$$

The main object of this paper are characteristics of the law F^0 of W under P^0 . In a single-server queue, F^0 boils down to the distribution of the stationary actual waiting time. In some cases, one is also interested in the law F of W as defined in (9) under P . This is the law of the X_0 vector that a tagged customer arriving at time 0 would experience, superimposed to the time-stationary arrival pattern. In a single-server queue, F boils down to the distribution of the stationary virtual waiting time. If N is Poisson, then F and F^0 coincide provided the marks are independent of the epochs of N .

3 Main Results

We show that under some assumptions stated below, the expectation $\mathbb{E}W$ of the stationary state variable W given in (9) is finite and that the components of $\mathbb{E}W$ can be expanded into a power series with respect to the arrival intensity λ . Moreover, we derive an explicit polynomial expression for the coefficients of this expansion.

As we will see in the next section (see particularly Lemmas 1 to 3), the assumptions stated below are satisfied whenever the recurrence equations (1) originate from a so-called *open stochastic event graph*.

3.1 Support and Monotonicity Assumptions

We assume that each entry of A_n is either a.s. non-negative or a.s. equal to ε , i.e.

$$(A_n)_{i,j} \geq 0 \quad \text{or} \quad (A_n)_{i,j} = \varepsilon, \quad \text{a.s.} \quad (11)$$

and that all entries on the diagonal of A_n are non-negative, i.e. $(A_n)_{ii} \geq 0$.

We also assume that there exists an integer $0 < \alpha' \leq \alpha$ such that the first α' coordinates of B_n are non-negative, i.e. $B_n^i \geq 0$ for all $i \leq \alpha'$. Moreover, the α -dimensional vectors D_0, D_1, \dots with $D_0 = B_0$ and

$$D_k = \left(\bigotimes_{n=1}^k A_{-n} \right) \otimes B_{-k} \quad \text{for} \quad k \geq 1, \quad (12)$$

are assumed to be such that

$$0 \leq D_0^i \leq D_1^i \leq \dots \quad (13)$$

for all $i = 1, \dots, \alpha'$.

3.2 Stochastic Assumptions

Throughout the rest of this paper we assume that $\{T_n\}$ is a stationary Poisson process with intensity λ , and $\{A_n, B_n\}$ is a stationary sequence of random matrices which is independent of $\{T_n\}$. Besides this we will assume that for $r \in \mathbb{N}$ large enough,

$$\lambda < r \left[\mathbf{E} \max_i \left\{ (A_{-1} \otimes A_{-2} \otimes \dots \otimes A_{-r} \otimes (B_{-r} \oplus O))^i \right\} \right]^{-1}, \quad (14)$$

where O is the α -dimensional column vector with all its components equal to zero. We also assume that for the same r as above, $\{H_n\}$ with

$$H_n = \max_i \left\{ (A_{-(nr+1)} \otimes A_{-(nr+2)} \otimes \dots \otimes A_{-(n+1)r} \otimes (B_{-(n+1)r} \oplus O))^i \right\} \quad (15)$$

is a sequence of 1-dependent random variables. Finally, we assume that

$$\mathbf{E} [(H_n)^{m+3}] < \infty \quad (16)$$

for some $m \in \mathbb{N}$.

3.3 Main Theorem

Theorem 2 *Under the above assumptions on $\{A_n, B_n\}$, for all $1 \leq i \leq \alpha'$,*

$$\mathbf{E} W^i = \sum_{k=0}^m \lambda^k \mathbf{E} p_{k+1}(D_0^i, D_1^i, \dots, D_k^i) + \mathcal{O}(\lambda^{m+1}). \quad (17)$$

The functions p_k are the following polynomials:

$$p_k(x_0, x_1, \dots, x_{k-1}) = \sum_{(i_0, i_1, \dots, i_{k-1}) \in \mathcal{S}_k} (-1)^{q_k(i_0, i_1, \dots, i_{k-1})} \frac{x_0^{i_0}}{i_0!} \frac{x_1^{i_1}}{i_1!} \dots \frac{x_{k-1}^{i_{k-1}}}{i_{k-1}!}, \quad (18)$$

where

$$S_k = \{(i_0, i_1, \dots, i_{k-1}) \in \{0, 1, \dots\}^k : i_0 + i_1 + \dots + i_{k-1} = k \text{ and if } i_s = l > 1, \\ \text{then } i_{s-1} = i_{s-2} = \dots = i_{s-l+1} = 0\},$$

(the $s - j$ are modulo k) and

$$q_k(i_0, i_1, \dots, i_{k-1}) = 1 + \sum_{s=0}^{k-1} \mathbf{1}(i_s > 0).$$

In particular, we get

$$p_1(x_0) = x_0, \quad p_2(x_0, x_1) = \frac{1}{2} [x_0^2 + x_1^2 - 2x_0x_1], \quad (19)$$

$$p_3(x_0, x_1, x_2) = \frac{1}{6} [x_0^3 + x_1^3 + x_2^3 - 3(x_0^2x_1 + x_1^2x_2 + x_2^2x_0) + 6x_0x_1x_2], \quad (20)$$

$$p_4(x_0, x_1, x_2, x_3) = \frac{1}{24} [x_0^4 + x_1^4 + x_2^4 + x_3^4 \\ - 4(x_0^3x_1 + x_1^3x_2 + x_2^3x_3 + x_3^3x_0) - 6(x_0^2x_2^2 + x_1^2x_3^2) \\ + 12(x_0^2x_1x_2 + x_1^2x_2x_3 + x_2^2x_3x_0 + x_3^2x_0x_1) - 24x_0x_1x_2x_3] \quad (21)$$

$$p_5(x_0, x_1, x_2, x_3, x_4) = \frac{1}{120} [x_0^5 + x_1^5 + x_2^5 + x_3^5 + x_4^5 \\ - 5(x_0^4x_1 + x_1^4x_2 + x_2^4x_3 + x_3^4x_4 + x_4^4x_0) \\ - 10(x_0^3x_2^2 + x_1^3x_3^2 + x_2^3x_4^2 + x_3^3x_0^2 + x_4^3x_1^2) \\ + 20(x_0^3x_1x_2 + x_1^3x_2x_3 + x_2^3x_3x_4 + x_3^3x_4x_5 + x_4^3x_0x_1) \\ + 30(x_0^2x_2^2x_3 + x_1^2x_3^2x_4 + x_2^2x_4^2x_5 + x_3^2x_0^2x_1 + x_4^2x_1^2x_2) \\ - 60(x_0^2x_1x_2x_3 + x_1^2x_2x_3x_4 + x_2^2x_3x_4x_5 + x_3^2x_4x_0x_1 + x_4^2x_0x_1x_2) \\ - 120x_0x_1x_2x_3x_4]. \quad (22)$$

The proof of Theorem 2 is given in Sections 5 and 6. First, in Section 5, a general expansion technique for functionals of marked point processes is used in order to show that an expansion of $\mathbb{E}W^i$ of the form (17) exists. The polynomial representation (18) of the coefficients $\mathbb{E}p_{k+1}(D_0^i, D_1^i, \dots, D_k^i)$ is derived in Section 6. In particular, it is shown that (17) is equivalent to

$$\mathbb{E}W^i = \mathbb{E}p_1(D_0^i) + \sum_{k=1}^m \lambda^k \mathbb{E}p_{k+1}(0, D_1^i - D_0^i, \dots, D_k^i - D_0^i) + \mathcal{O}(\lambda^{m+1}). \quad (23)$$

However, before stating the proof of Theorem 2 in detail, we give some examples of application in Section 4.

Remark We found no earlier use of this class of polynomials in the literature. Below we summarize some of their key properties (see also Section 6):

1. The polynomials p_k , $k \geq 1$, are invariant with respect to circular permutation, i.e.

$$p_k(x_0, x_1, \dots, x_{k-1}) = p_k(x_1, x_2, \dots, x_{k-1}, x_0)$$

for all $x_0, \dots, x_{k-1} \in \mathbb{R}$.

2. The polynomials p_k , $k \geq 2$, are 1-invariant, i.e. for all $t \in \mathbb{R}$,

$$p_k(x_0, x_1, \dots, x_{k-1}) = p_k(x_0 + t, x_1 + t, \dots, x_{k-1} + t).$$

3. The polynomials p_k , $k \geq 1$, satisfy the integral recurrence relation:

$$p_{k+1}(x_0, x_1, \dots, x_k) = \sum_{n=0}^{k-1} \int_{x_n - x_0}^{x_{n+1} - x_0} \left[p_k(\underbrace{x_0, \dots, x_0}_n, x_{n+1} - u, \dots, x_k - u) - p_k(\underbrace{x_0, \dots, x_0}_{n+1}, x_{n+1} - u, \dots, x_{k-1} - u) \right] du.$$

4. For all $k \geq 2$,

$$\begin{aligned} p_k(0, \dots, 0) &= 0 \\ p_k(1, \dots, k) &= \frac{1}{2}. \end{aligned}$$

5. For all $t \in \mathbb{R}$,

$$p_k(tx_0, tx_1, \dots, tx_{k-1}) = t^k p_k(x_0, x_1, \dots, x_{k-1}).$$

4 Examples

In this section we provide several examples of discrete event systems with the state variables satisfying a vectorial recurrence equation of type (1).

4.1 Stochastic Event Graphs

A *Petri net* is defined as a tuple $PN = (\mathcal{P}, \mathcal{T}, \mathcal{F}, \mathcal{M}_0)$, where

$$\begin{aligned} \mathcal{P} &= \{p_1, p_2, \dots, p_P\} \text{ is the set of places} \\ \mathcal{T} &= \{u_1, u_2, \dots, u_\beta\} \text{ is the set of transitions} \\ \mathcal{F} &\subseteq (\mathcal{P} \times \mathcal{T}) \cup (\mathcal{T} \times \mathcal{P}) \text{ is the set of arcs} \\ \mathcal{M}_0 &: \mathcal{P} \rightarrow \{0, 1, 2, 3, \dots, M\} \text{ is the initial marking.} \end{aligned}$$

A Petri net is an *event graph* if each place has not more than one input and one output arc. A *Timed Petri Net* is a net with firing times associated with the transitions. The firing time of a transition is the time that elapses between the starting and the completion of the firing of the transition. If firing times are random variables, we speak of a *Stochastic Petri Net*. A typical situation is that when the sequence $\{\sigma_n^1, \dots, \sigma_n^\beta\}_n$, where σ_n^i is the n -th firing time of transition i , is i.i.d. In what follows, these independence conditions are assumed to be satisfied and will be referred to as a *GI-stochastic event graph* later on. This admits as a particular case the situation when the successive firing times of transition i are i.i.d. for all i , and in addition, the firing times of the various transitions are all mutually independent.

Besides this we always assume that the expected firing times are finite. We remark however that all our arguments used below (in particular, those used in Section 5.3) remain true in the case when the n -th random firing times of several transitions are realized at once and, therefore, are not independent. In

this way, the tandem queues with identical successive service times considered e.g. in [14, 27] can also be investigated by our expansion results. Moreover, our arguments easily extend to the case that within the sequence of n -th, $(n+1)$ -th, ... firing-time vectors there is a correlation structure of finite range.

To any stochastic event graph, we associate a set of random matrices $A_0(n), A_1(n), \dots, A_M(n)$, all of dimension $\beta \times \beta$, defined as follows: $M < \infty$ is the maximal initial marking. The entry i, j of matrix $A_k(n)$ is the firing time σ_{n-k}^j of the $(n-k)$ -th firing of transition u_j , whenever there is a place p with k tokens in the initial marking, and a path $u_j \rightarrow p \rightarrow u_i$ (namely an arc from u_j to p and one from p to u_i). If there is no such place, this entry is given the value ε ($= -\infty$).

To the above event graph, we may add an input structure, namely an input transition u with no input arcs, input places that connect u to the internal transitions of the net, and a real-valued increasing sequence input function T_n (with the interpretation that T_n is the epoch of the n -th external arrival to the input transition u). For the sake of simplicity, we will assume that all input places have a 0 initial marking, so that M will again denote the maximal initial marking in all places (including input places). Associated with such a structure goes the sequence of matrices $B_0(n)$, of dimension $\beta \times 1$, defined as follows: the entry $i, 1$ of matrix $B_0(n)$ is 0 whenever there is an input place p and a path $u \rightarrow p \rightarrow u_i$, and ε otherwise.

The following results are taken from [2]. Theorem 3 concerns FIFO event graphs, i.e. event graphs such that all its places and transitions are FIFO. A sufficient condition for the event graph to be FIFO is that the matrices $A_1(n)$ have no ε on their principal diagonal. We will also assume that this condition holds. A deterministic event graph (i.e. all internal transitions have a constant (deterministic) firing time sequence, the value of which may depend on the transition) is always FIFO, even whenever the last condition is not satisfied.

Theorem 3 *For any FIFO event graph, let x_n^i denote the epoch when transition u_i starts firing for the n -th time, and let x_n be the column vector given by $x'_n = (x_n^1, x_n^2, \dots, x_n^\beta)$, where x'_n denotes transposition of x_n . Then the x_n satisfy the following (max, +)-recurrence equation, for all $n \geq M$:*

$$x_n = \bigoplus_{k=0}^M A_k(n) \otimes x_{n-k} \oplus B_0(n) \otimes T_n \quad (24)$$

with the initial conditions x_0, x_1, \dots, x_{M-1} .

Theorem 4 concerns FIFO *deadlock-free* event graphs, i.e. event graphs such that for each marking $\nu : \mathcal{P} \rightarrow \{0, 1, \dots\}$ reachable from the initial marking \mathcal{M}_0 and for each transition $\tau \in \mathcal{T}$, there exists a marking $\mu : \mathcal{P} \rightarrow \{0, 1, \dots\}$ which is reachable from ν such that τ is enabled from μ . A necessary and sufficient condition for the event graph to be deadlock-free is that the matrices $A_0(n)$ are strictly lower triangular for an appropriate numbering of the transitions, i.e. all entries i, j of the matrices $A_0(n)$ with $i \leq j$ are equal to ε . In that case, we define the following matrices:

- $A_0^*(n)$ is the $\beta \times \beta$ matrix

$$A_0^*(n) = \bigoplus_{k \geq 0} A_0^k(n), \quad (25)$$

where, for all A , $A^0 = E$ is the (max, +)-identity matrix (i.e. all diagonal elements are 0, and all non-diagonal ones are ε), and $A^{k+1} = A^k \otimes A$. The series defined in (25) converges whenever $A_0(n)$ is strictly lower triangular;

- $\bar{A}_k(n)$ is the $\beta \times \beta$ matrix

$$\bar{A}_k(n) = A_0^*(n) \otimes A_k(n); \quad (26)$$

- $\bar{B}_0(n)$ is the $\beta \times 1$ matrix

$$\bar{B}_0(n) = A_0^*(n) \otimes B_0(n); \quad (27)$$

- A_n is the $M\beta \times M\beta$ matrix

$$A_n = \begin{pmatrix} \bar{A}_1(n+1) & \bar{A}_2(n+1) & \dots & \dots & \bar{A}_M(n+1) \\ E & \mathcal{E} & \dots & \mathcal{E} & \mathcal{E} \\ \mathcal{E} & E & \ddots & \vdots & \mathcal{E} \\ \vdots & \ddots & E & \mathcal{E} & \mathcal{E} \\ \mathcal{E} & \dots & \mathcal{E} & E & \mathcal{E} \end{pmatrix}, \quad (28)$$

where E is the $\beta \times \beta$ - $(\max, +)$ -identity matrix and \mathcal{E} denotes the $(\max, +)$ -zero matrix (i.e. the $\beta \times \beta$ matrix with all entries equal to ε).

- B_n is the $M\beta \times 1$ matrix

$$B_n = \begin{pmatrix} \bar{B}_0(n) \\ \varepsilon \\ \vdots \\ \varepsilon \end{pmatrix}; \quad (29)$$

- X_n is the $M\beta$ -dimensional vector

$$X_n = \begin{pmatrix} x_n \\ x_{n-1} \\ \vdots \\ x_{n-M+1} \end{pmatrix}. \quad (30)$$

Theorem 4 For any FIFO deadlock-free event graph and for $n \geq M - 1$, the X_n satisfy (1), with $\alpha = M\beta$, and with A_n and B_n defined in (28) and (29), respectively.

Remark There is a converse theorem, proved in [6], which states that for all $(\max, +)$ -linear equations of type (1), one can construct a FIFO stochastic event graph with these evolution equations.

Moreover note that, since the event graph is FIFO, we always have $x_n^i \geq x_{n-1}^i$. So, in the definition (28) of A_n , we can replace each \mathcal{E} matrix of the main diagonal by E , without altering the solution of the recurrence equations. Thus, there is an equivalent representation of the system where the A_n matrix is

$$A_n = \begin{pmatrix} \bar{A}_1(n+1) & \bar{A}_2(n+1) & \dots & \dots & \bar{A}_M(n+1) \\ E & E & \dots & \mathcal{E} & \mathcal{E} \\ \mathcal{E} & E & \ddots & \vdots & \mathcal{E} \\ \vdots & \ddots & E & E & \mathcal{E} \\ \mathcal{E} & \dots & \mathcal{E} & E & E \end{pmatrix}, \quad (31)$$

and has all its diagonal entries non-negative.

In what follows, we will assume that the network is “input connected”, namely that $\overline{B}_0(n) \geq 0$ for all n . We conclude this section by a few lemmas showing that, under the stability condition $\rho < 1$ of Theorem 1, stochastic Petri nets of this class satisfy the assumptions stated in Sections 3.1 and 3.2 (with $\alpha = M\beta$ and $\alpha' = \beta$).

Lemma 1 *Let a denote the maximal $(\max, +)$ -Lyapunov exponent of $\{A_n\}$. If $\lambda a < 1$, then for r large enough,*

$$\lambda < r \left[\mathbb{E} \max_i \{ (A_{-1} \otimes A_{-2} \otimes \dots \otimes A_{-r} \otimes (B_{-r} \oplus O))^i \} \right]^{-1}, \quad (32)$$

where O denotes the $M\beta$ -dimensional vector with all its coordinates equal to zero.

Proof One of the characterizations of the Lyapunov exponent a is

$$a = \lim_{r \rightarrow \infty} \frac{\mathbb{E} \max_{i,j} \{ (A_{-1} \otimes \dots \otimes A_{-r})_{i,j} \}}{r} \quad (33)$$

(see [6]). So under the condition $\lambda a < 1$, there exists an integer R such that for all $r \geq R$,

$$\lambda \frac{\mathbb{E} \max_{i,j} \{ (A_{-1} \otimes \dots \otimes A_{-r})_{i,j} \}}{r} < 1. \quad (34)$$

But

$$\begin{aligned} & \mathbb{E} \max_i \{ (A_{-1} \otimes \dots \otimes A_{-r} \otimes (B_{-r} \oplus O))^i \} \\ & \leq \mathbb{E} \left[\max_{i,j} \{ (A_{-1} \otimes \dots \otimes A_{-r})_{i,j} \} \right] + \mathbb{E} \left[\max_i \{ (B_{-r})^i \} \right]. \end{aligned} \quad (35)$$

Since the B_n 's are identically distributed and all non ε entries of B_0 are supposed to be integrable, we have

$$\lim_{r \rightarrow \infty} \frac{\mathbb{E} \max_i \{ B_{-r}^i \}}{r} = 0. \quad (36)$$

This, (34) and (35) imply that there exists an integer R' such that (32) holds for all $r \geq R'$. \square

Lemma 2 *Consider an input-connected stochastic event graph such that the sequence $\{B_0(n)\}$ is constant (we assumed this to be the case above). Then for all integers s , the sequence*

$$A_{-s} \otimes A_{-s-1} \otimes \dots \otimes A_{-s-n} \otimes B_{-s-n}$$

is non-decreasing in n ; in particular, for all $i = 1, \dots, \beta$,

$$0 \leq D_0^i \dots \leq D_n^i \leq D_{n+1}^i \dots$$

Proof Since $A_0^*(n) \geq E$, we obtain from (27) that

$$\overline{B}_0(n) \geq J \quad (37)$$

where J denotes the constant vector equal to $B_0(n)$ for all n . In view of the definition of B_n in (29), we obtain that

$$B_n \geq \begin{pmatrix} J \\ \varepsilon \\ \vdots \\ \varepsilon \end{pmatrix}.$$

Similarly, since all transitions are recycled, the matrices $A_1(n)$ are such that $A_1(n) \geq E$. So $\overline{A}_1(n)$ defined in (26) is such that

$$\overline{A}_1(n) \geq A_0^*(n). \quad (38)$$

From (37) and (38), we obtain that

$$\overline{A}_1(-n+1) \otimes \overline{B}_0(-n) \geq A_0^*(-n+1) \otimes J = \overline{B}_0(-n+1). \quad (39)$$

When making use of this inequality in the definitions of A_n and D_n , we obtain that

$$A_{-n} \otimes B_{-n} \geq B_{-n+1}, \quad (40)$$

which completes the proof of the first monotonicity property.

So in particular, $D_n \geq D_{n-1}$. The only additional property to prove is that for the first β coordinates of D_0 , $D_0^i = B_0^i \geq 0$. But this follows from the assumption that the network is input-connected. \square

Lemma 3 *For all GI-stochastic event graphs (i.e. the firing-time sequences $\{\sigma_n^1, \dots, \sigma_n^\beta\}_n$ are i.i.d. in n) with maximal initial marking equal to M , the sequence $\{A_n, B_n\}$ is M -dependent.*

Proof In view of (28) and (29), the random matrices A_n and B_n are functions of the random variables

$$\{\sigma_{n+1}^j, \sigma_n^j, \dots, \sigma_{n+1-M}^j, j \in \mathcal{T}\}$$

only. This means that under the above independence assumptions, for all n , the random matrices $\{(A_{n-l}, B_{n-l}), l \geq 0\}$ are independent of the random matrices $\{(A_{n+M+k}, B_{n+M+k}), k \geq 1\}$. \square

4.2 Queueing Networks

The aim of this section is to give a few practical examples of queueing, communication and manufacturing systems that fall in the class of stochastic event graphs and to apply our main theorem to these systems. For all examples given in this section, the maximal initial marking is $M = 1$, with the exception of the Kanban system where we take $M = 2$.

4.2.1 Single-Server Queue

Consider a single-server FIFO queue with infinite capacity which is initially empty. This is the system of Fig. 1.

Here, $\beta = 1$, $A_n = \sigma_n$ represents the service time of the n -th customer, and $B_n = 0$, so that (5) reads

$$W_{n+1} = (\sigma_n \otimes (-\tau_n) \otimes W_n) \oplus 0 \quad \text{with} \quad W_0 = 0, \quad (41)$$

that is Lindley's equation for the actual waiting time W_{n+1} of the $(n+1)$ -th customer.

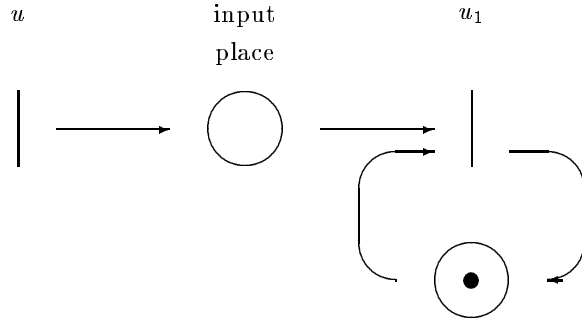

Figure 1: Single-Server Queue

In this simple case, $D_0 = 0$ and $D_k = \sum_{n=1}^k \sigma_{-n}$, and direct computations give

$$\begin{aligned}
 p_2(D_0, D_1) &= \frac{1}{2}\sigma_{-1}^2 \\
 p_3(D_0, D_1, D_2) &= \frac{1}{6}(\sigma_{-2}^3 - \sigma_{-1}^3 + 3\sigma_{-1}\sigma_{-2}^2) \\
 p_4(D_0, D_1, D_2, D_3) &= \frac{1}{24}(\sigma_{-1}^4 - 2\sigma_{-2}^4 + \sigma_{-3}^4 \\
 &\quad + 4(\sigma_{-1}\sigma_{-3}^3 - 2\sigma_{-1}\sigma_{-2}^3 + \sigma_{-2}\sigma_{-3}^3)) \\
 &\quad - 6(\sigma_{-1}^2\sigma_{-2}^2 - \sigma_{-2}^2\sigma_{-3}^2) \\
 &\quad + 12(\sigma_{-1}\sigma_{-2}\sigma_{-3}^2).
 \end{aligned}$$

Assume that the stability condition $\lambda\mathbb{E}[\sigma_n] < 1$ is satisfied and that $E[\sigma_n^6] < \infty$, so that we can apply Theorem 2 for the expansion of order $m = 3$, whenever the sequence $\{\sigma_n\}$ is i.i.d. From the previous expressions for $p_k(D_0, D_1, \dots, D_{k-1})$, we obtain

$$\mathbb{E}p_2(D_0, D_1) = \frac{\mathbb{E}[\sigma_n^2]}{2}, \quad \mathbb{E}p_3(D_0, D_1, D_2) = \frac{\mathbb{E}[\sigma_n^2]\mathbb{E}[\sigma_n]}{2}$$

and

$$\mathbb{E}p_4(D_0, D_1, D_2, D_3) = \frac{\mathbb{E}[\sigma_n^2]\mathbb{E}[\sigma_n]^2}{2},$$

so that

$$\mathbb{E}W = \lambda \frac{\mathbb{E}[\sigma_n^2]}{2} + \lambda^2 \frac{\mathbb{E}[\sigma_n^2]\mathbb{E}[\sigma_n]}{2} + \lambda^3 \frac{\mathbb{E}[\sigma_n^2]\mathbb{E}[\sigma_n]^2}{2} + \mathcal{O}(\lambda^4). \quad (42)$$

Of course, in this case, there are far more efficient ways of obtaining such an expansion, like for instance a direct use of the Pollaczek-Khinchine mean value formula which gives:

$$\mathbb{E}W = \frac{\lambda\mathbb{E}[\sigma_n^2]}{2(1 - \lambda\mathbb{E}[\sigma_n])} = \frac{\mathbb{E}[\sigma_n^2]}{2} \sum_{k=1}^{\infty} \lambda^k \mathbb{E}[\sigma_n]^{k-1}, \quad (43)$$

under the sole assumption that $\mathbb{E}[\sigma_n^2] < \infty$. However our expansion technique extends to the case when the sequence of service times possesses a correlation structure of finite range (cf. the remarks at the beginning of Section 4.1). Moreover, we can expand not only the expectation $\mathbb{E}W$, but also higher-order moments of W for which a closed formula of type (43) cannot be concluded from the Pollaczek-Khinchine theorem when service times are not independent. This and related topics for further characteristics of W will be the subject of future research.

4.2.2 Tandem Queues

Consider a network of β single-server FIFO queues with infinite capacity in tandem (see Fig. 2), with all queues initially empty. For this system, the matrices $A_0(n)$, $A_1(n)$ and $B_0(n)$ have the following form:

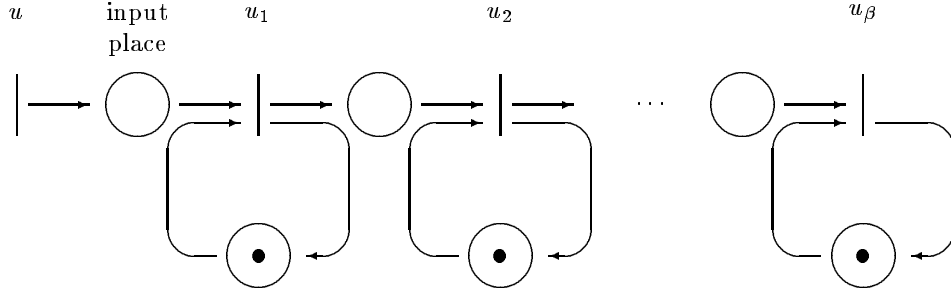

Figure 2: Tandem Queues with Infinite Capacity

$$A_0(n) = \begin{pmatrix} \varepsilon & \varepsilon & \cdots & \varepsilon & \varepsilon & \varepsilon \\ \sigma_n^1 & \varepsilon & \cdots & \varepsilon & \varepsilon & \varepsilon \\ \varepsilon & \sigma_n^2 & \cdots & \varepsilon & \varepsilon & \varepsilon \\ \vdots & & & & & \\ \varepsilon & \varepsilon & \cdots & \sigma_n^{\beta-2} & \varepsilon & \varepsilon \\ \varepsilon & \varepsilon & \cdots & \varepsilon & \sigma_n^{\beta-1} & \varepsilon \end{pmatrix}, \quad B_0(n) = \begin{pmatrix} 0 \\ \varepsilon \\ \varepsilon \\ \vdots \\ \varepsilon \\ \varepsilon \\ \varepsilon \end{pmatrix}, \quad (44)$$

and

$$A_1(n) = \begin{pmatrix} \sigma_{n-1}^1 & \varepsilon & \varepsilon & \cdots & \varepsilon & \varepsilon \\ \varepsilon & \sigma_{n-1}^2 & \varepsilon & \cdots & \varepsilon & \varepsilon \\ \varepsilon & \varepsilon & \sigma_{n-1}^3 & \cdots & \varepsilon & \varepsilon \\ \vdots & & & & & \\ \varepsilon & \varepsilon & \varepsilon & \cdots & \sigma_{n-1}^{\beta-1} & \varepsilon \\ \varepsilon & \varepsilon & \varepsilon & \cdots & \varepsilon & \sigma_{n-1}^\beta \end{pmatrix}. \quad (45)$$

So that the entries $(A_n)_{ij}$ of the matrix A_n are given by

$$(A_n)_{ij} = \begin{cases} \varepsilon & \text{if } i < j \\ \sum_{k=j}^{i-1} \sigma_{n+1}^k + \sigma_n^j & \text{if } i \geq j \end{cases} \quad (46)$$

and

$$B_n = \begin{pmatrix} 0 \\ \sigma_n^1 \\ \sigma_n^1 + \sigma_n^2 \\ \sigma_n^1 + \sigma_n^2 + \sigma_n^3 \\ \vdots \\ \sum_{k=1}^{\beta-1} \sigma_n^k \end{pmatrix}. \quad (47)$$

Then, the i -th component W^i of the random vector W given by (9) describes the stationary waiting time of a randomly chosen customer until the beginning of service on server i , where the matrices D_n in (10) have the following form. From (46) we get that

$$(A_{-1} \otimes A_{-2})_{ij} = \begin{cases} \varepsilon & \text{if } i < j \\ \max_{j \leq l \leq i} \left\{ \sum_{k=l}^{i-1} \sigma_0^k + \sum_{k=j}^l \sigma_{-1}^k + \sigma_{-2}^j \right\} & \text{if } i \geq j \end{cases}$$

and, for general $n \geq 1$, the entries $(A_{-1} \otimes A_{-2} \otimes \dots \otimes A_{-n})_{ij}$ are equal to:

$$\begin{cases} \varepsilon & \text{if } i < j, \\ \max_{j \leq l_{n-1} \leq \dots \leq l_1 \leq i} \left\{ \sum_{k=l_1}^{i-1} \sigma_0^k + \sum_{k=l_2}^{l_1} \sigma_{-1}^k + \dots + \sum_{k=l_{n-1}}^{l_{n-2}} \sigma_{-n+2}^k + \sum_{k=j}^{l_{n-1}} \sigma_{-n+1}^k + \sigma_{-n}^j \right\} & \text{if } i \geq j. \end{cases}$$

Thus, using (47), we have

$$\begin{aligned} D_n^i &= (A_{-1} \otimes A_{-2} \otimes \dots \otimes A_{-n} \otimes B_{-n})^i \\ &= \max_{1 \leq l_n \leq \dots \leq l_1 \leq i} \left\{ \sum_{k=l_1}^{i-1} \sigma_0^k + \sum_{k=l_2}^{l_1} \sigma_{-1}^k + \dots + \sum_{k=l_n}^{l_{n-1}} \sigma_{-n+1}^k + \sum_{k=1}^{l_n} \sigma_{-n}^k \right\} \end{aligned} \quad (48)$$

(see [5] for more details on this formula). Consider now the particular case when the service times are deterministic. By σ^i we denote the service time in queue $i \in \{1, \dots, \beta\}$. Without loss of generality we can and will assume that $\sigma^1 \leq \sigma^2 \leq \dots \leq \sigma^\beta$. In the other case, say $\sigma^i > \sigma^{i+1}$ for some $i < \beta$, we can consider the i -th queue and the $(i+1)$ -th queue as *one* single-server queue with service time $\sigma^i + \sigma^{i+1}$ because in front of the $(i+1)$ -th server the waiting room is always empty. By this assumption on service times we get from (48)

$$D_n = \begin{pmatrix} n\sigma^1 \\ \sigma^1 + n\sigma^2 \\ \sigma^1 + \sigma^2 + n\sigma^3 \\ \sigma^1 + \sigma^2 + \sigma^3 + n\sigma^4 \\ \vdots \\ \sum_{k=1}^{\beta-1} \sigma^k + n\sigma^\beta \end{pmatrix}. \quad (49)$$

For systems with deterministic service times, we will use the following abbreviating notation, which is consistent with the $(\max, +)$ -setting. Namely, we write i^k instead of $k\sigma^i$, and $i^k j^l$ instead of $k\sigma^i + l\sigma^j$. With this notation

$$D_n = \begin{pmatrix} 1^n \\ 12^n \\ 123^n \\ 1234^n \\ \vdots \\ 123 \dots \beta^n \end{pmatrix}. \quad (50)$$

Expansions–Deterministic Service Times Case From (17) and (18) and from (49), we get the following Taylor expansion for the expected stationary waiting time $\mathbb{E}W^i$ which an arbitrarily chosen custo-

mer has to spend in the network until the beginning of his service in queue i , where $c_1 = \sum_{l=1}^{i-1} \sigma^l$, $c_2 = \sigma^i$:

$$\mathbb{E}W^i = c_1 + \lambda \frac{c_2^2}{2} + \lambda^2 \frac{c_2^3}{2} + \lambda^3 \frac{c_2^4}{2} + \dots \quad (51)$$

Note that the coefficient $\frac{c_2^2}{2}$ of the linear term of this expansion is equal to the expected stationary residual service time in queue i whereas the coefficients of the second-order and third-order terms seem to be less intuitive. At first glance, it looks surprising that the coefficients of *all* orders depend on $c_2 = \sigma^i$ only, but *not* on the service times $\sigma^1, \sigma^2, \dots, \sigma^{i-1}$ in the earlier stations. However, the fact that

$$\mathbb{E}W^i = c_1 + \lambda \frac{c_2^2}{2} \left(\frac{1}{1 - \lambda c_2} \right)$$

is well-known in queueing theory. For example, it can easily be concluded from an invariance property derived in [21] for tandem queues with infinite buffers and constant service times.

Expansions–Random Service Times Case Assume that

$$\mathbb{E}(\sigma_n^i)^{k+3} < \infty \quad \text{for every } i \in \{1, \dots, \beta\}. \quad (52)$$

It is easy to see that the integrability condition (16) is then satisfied. Moreover, from (19) and (48) we get the following expression for the absolute term $\mathbb{E}p_1(D_0^i)$ in the expansion (17) of $\mathbb{E}W^i$:

$$\mathbb{E}p_1(D_0^i) = \mathbb{E}D_0^i = \sum_{k=1}^{i-1} \mathbb{E}\sigma_0^k.$$

In the same way we get the following expression for the coefficient $\mathbb{E}p_2(D_0^i, D_1^i)$ of the linear term:

$$\mathbb{E}p_2(D_0^i, D_1^i) = \frac{1}{2} \mathbb{E}(D_1^i - D_0^i)^2$$

and for the coefficient $\mathbb{E}p_3(D_0^i, D_1^i, D_2^i)$ of the quadratic term

$$\mathbb{E}p_3(D_0^i, D_1^i, D_2^i) = \frac{1}{6} \{ \mathbb{E}(D_1^i - D_0^i)^3 + \mathbb{E}(D_2^i - D_0^i)^3 - 3\mathbb{E}(D_1^i - D_0^i)^2(D_2^i - D_0^i) \},$$

where

$$D_1^i - D_0^i = \max_{1 \leq l \leq i} \left\{ \sigma_{l-1}^i + \sum_{k=1}^{l-1} (\sigma_{k-1}^i - \sigma_0^k) \right\}$$

and

$$D_2^i - D_0^i = \max_{1 \leq l_2 \leq l_1 \leq i} \left\{ \sigma_{l_2-2}^i + \sum_{k=1}^{l_2-1} (\sigma_{k-2}^i - \sigma_0^k) + \sigma_{l_1-1}^i + \sum_{k=l_2}^{l_1-1} (\sigma_{k-1}^i - \sigma_0^k) \right\}.$$

Let us now consider a few special cases:

- Assume that $\beta = i = 2$ and $\sigma_n^1 = c$ deterministic. Then, we have

$$D_1^2 - D_0^2 = \max\{c, \sigma_{-1}^2\} \quad \text{and} \quad D_2^2 - D_0^2 = \max\{2c, c + \sigma_{-1}^2, \sigma_{-2}^2 + \sigma_{-1}^2\}.$$

With the notation $G(x) = P(\sigma_n^2 \leq x)$, this gives

$$\mathbb{E}p_2(D_0^2, D_1^2) = \frac{1}{2} \left\{ c^2 G(c) + \int_c^\infty x^2 dG(x) \right\}$$

and

$$\begin{aligned}
& \mathbb{E}p_3(D_0^2, D_1^2, D_2^2) \\
&= \frac{1}{6} \left\{ c^3 G(c) + \int_c^\infty x^3 dG(x) + 8c^3 [G(c)]^2 + G(c) \int_c^\infty (c+x)^3 dG(x) \right. \\
&+ \int_c^\infty \int_c^\infty (x+y)^3 dG(y) dG(x) - 6c^3 [G(c)]^2 - 3G(c) \int_c^\infty x^2 (c+x) dG(x) \left. \right\} \\
&- 3 \int_c^\infty \int_c^\infty x^2 (x+y) dG(y) dG(x) \\
&= \frac{1}{6} \left\{ c^2 G(c) \left[c+1 + G(c)(2c-1) + 3\tilde{G}_1(c) \right] + 3\tilde{G}_1(c)\tilde{G}_2(c) - 2G(c)\tilde{G}_3(c) \right\},
\end{aligned}$$

where $\tilde{G}_j(c) = \int_c^\infty x^j dG(x)$.

- Assume now that $\beta = 3$ and $\sigma_n^i = \sigma(n)$ for all i , a model which was for instance considered in [14]. In this case, we obtain the following expressions:

$$\begin{aligned}
D_0^3 &= 2\sigma(0) \\
D_1^3 &= \sigma(1) + 2 \max\{\sigma(0), \sigma(1)\} \\
D_2^3 &= \sigma(1) + \sigma(2) + 2 \max\{\sigma(0), \sigma(1), \sigma(2)\},
\end{aligned}$$

so that

$$\begin{aligned}
\mathbb{E}[W^3] &= 2\mathbb{E}[\sigma(0)] + \lambda \frac{1}{2} (\mathbb{E}[\sigma(0)] + 2\mathbb{E}[(\sigma(1) - \sigma(0))^+]) \\
&+ \lambda^2 \frac{1}{6} (2\mathbb{E}[\sigma(0)] + 2\mathbb{E}[\max\{(\sigma(1) - \sigma(0))^+, \sigma(2)\sigma(0)\}]) + \mathcal{O}(\lambda^3),
\end{aligned}$$

where $x^+ = \max\{x, 0\}$.

4.2.3 Blocking Queues in Tandem

Consider a system of four single-server FIFO queues in tandem depicted by the Petri net of Figure 3. The first station, which is fed by the arrival point process, has an infinite capacity buffer, whereas all other stations have no buffering capacity. Here, the mechanism is that of “blocking after service”, i.e. in each station, a customer can always start its service but once its service is completed, the customer can only proceed to the downstream station whenever this one is empty (this is also called *manufacturing blocking*). In Figure 3, the places of type p_1 represent the recycling of the servers, the places of type p_2 represent the servers and the places of type p_3 are used to enforce the blocking. The transition that precedes place p_2 in station 1 has a constant firing time equal to σ^1 , whereas the transition which follows this place has a firing time equal to 0. A similar structure is repeated in all stations, the only difference being in the value of the service times which are equal to σ^i in station i . In the initial state, all stations are empty. Let us take as state variables the variables x_n^i where x_n^i gives the time when customer n leaves station i (or equivalently the time when the transition which follows the place of type p_2 in station i starts its n -th firing).

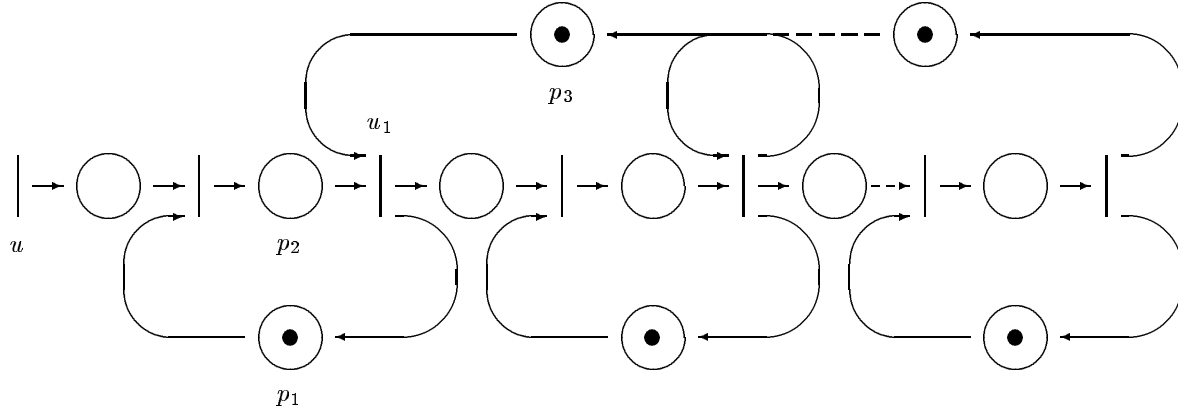

Figure 3: Blocking After Service

When eliminating the state variables corresponding to the transitions that precede the places of type p_2 , we obtain that the resulting state vectors x_n satisfy a recurrence equation of type (24) with:

$$A_0(n) = \begin{pmatrix} \varepsilon & \varepsilon & \varepsilon & \varepsilon \\ 2 & \varepsilon & \varepsilon & \varepsilon \\ \varepsilon & 3 & \varepsilon & \varepsilon \\ \varepsilon & \varepsilon & 4 & \varepsilon \end{pmatrix}, \quad A_1(n) = \begin{pmatrix} 1 & 0 & \varepsilon & \varepsilon \\ \varepsilon & 2 & 0 & \varepsilon \\ \varepsilon & \varepsilon & 3 & 0 \\ \varepsilon & \varepsilon & \varepsilon & 4 \end{pmatrix}, \quad B_0(n) = \begin{pmatrix} 1 \\ \varepsilon \\ \varepsilon \\ \varepsilon \end{pmatrix}.$$

Let us assume that $\sigma_1 \leq \sigma_2 \leq \sigma_3 \leq \sigma_4$. Then

$$A = A_0^*(0) \otimes A_1(0) = \begin{pmatrix} 1 & 0 & \varepsilon & \varepsilon \\ 12 & 2 & 0 & \varepsilon \\ 123 & 23 & 3 & 0 \\ 1234 & 234 & 34 & 4 \end{pmatrix}, \quad B = A_0^*(0) \otimes B_0(0) = \begin{pmatrix} 1 \\ 12 \\ 123 \\ 1234 \end{pmatrix}.$$

Finally, the matrices D_n defined in (10) are given by

$$D_0 = \begin{pmatrix} 1 \\ 12 \\ 123 \\ 1234 \end{pmatrix}, \quad D_1 = \begin{pmatrix} 12 \\ 123 \\ 1234 \\ 1234^2 \end{pmatrix}, \quad D_2 = \begin{pmatrix} 123 \\ 1234 \\ 1234^2 \\ 1234^3 \end{pmatrix}, \quad (53)$$

and for $n \geq 3$,

$$D_n = \begin{pmatrix} 1234^{n-2} \\ 1234^{n-1} \\ 1234^n \\ 1234^{n+1} \end{pmatrix}. \quad (54)$$

The results are easily generalized to a general dimension β , and the vectors $W_n = (W_n^1, \dots, W_n^\beta)$ satisfy the recurrence equation

$$W_{n+1} = A \otimes C(\tau_n) \otimes W_n \oplus B,$$

with

$$A = \begin{pmatrix} 1 & 0 & \varepsilon & \varepsilon & \varepsilon & \dots \\ 12 & 2 & 0 & \varepsilon & \varepsilon & \dots \\ 123 & 23 & 3 & 0 & \varepsilon & \dots \\ \vdots & & & & & \\ 123\dots\beta & 23\dots\beta & \dots & & & \beta \end{pmatrix}$$

and

$$B = \begin{pmatrix} 1 \\ 12 \\ 123 \\ \vdots \\ 123\dots\beta \end{pmatrix}.$$

Using the fact that $\sigma^1 < \sigma^2 < \dots < \sigma^\beta$, we get that for $n \leq \beta$,

$$A^n = \begin{pmatrix} 123\dots n & 23\dots n & \dots & n & 0 & \varepsilon & \varepsilon & \dots \\ 123\dots n+1 & 23\dots n+1 & \dots & \dots & n+1 & 0 & \varepsilon & \dots \\ \vdots & & & & & & & \\ 123\dots\beta & 23\dots\beta & \dots & & & & & \beta \\ 123\dots\beta^2 & 23\dots\beta^2 & \dots & & & & & \beta^2 \\ 123\dots\beta^n & 23\dots\beta^n & \dots & & & & & \beta^n \end{pmatrix}$$

whereas for $n \geq \beta$,

$$A^n = \begin{pmatrix} 12\dots\beta^{n-\beta} & 2\dots\beta^{n-\beta} & \dots & \beta^{n-\beta} \\ 12\dots\beta^{n+1-\beta} & 2\dots\beta^{n+1-\beta} & \dots & \beta^{n+1-\beta} \\ \vdots & & & \\ 12\dots\beta^n & 2\dots\beta^n & \dots & \beta^n \end{pmatrix}.$$

This gives

$$D_n = A^n \otimes B = \begin{pmatrix} \sum_{k=1}^{(n+1)\wedge\beta} \sigma^k + (n+1-\beta)^+\sigma^\beta \\ \sum_{k=1}^{(n+2)\wedge\beta} \sigma^k + (n+2-\beta)^+\sigma^\beta \\ \vdots \\ \sum_{k=1}^{\beta} \sigma^k + n\sigma^\beta \end{pmatrix}.$$

Expansions Using the same approach as before, we obtain

$$\begin{aligned} \mathbb{E}W^i &= d_0 + \lambda \frac{(d_1 - d_0)^2}{2} + \lambda^2 \frac{1}{6} [(d_1 - d_0)^3 + (d_2 - d_0)^3 - 3(d_1 - d_0)^2(d_2 - d_0)] \\ &\quad + \lambda^3 \frac{1}{24} [(d_1 - d_0)^4 + (d_2 - d_0)^4 + (d_3 - d_0)^4 - 4((d_1 - d_0)^3(d_2 - d_0) \\ &\quad + (d_2 - d_0)^3(d_3 - d_0)) - 6(d_1 - d_0)^2(d_3 - d_0)^2 + 12(d_1 - d_0)^2 \\ &\quad + 12(d_1 - d_0)^2(d_2 - d_0)(d_3 - d_0)] + \mathcal{O}(\lambda^4) \end{aligned}$$

where

$$d_n (= D_n^i) = \sum_{j=1}^{(n+i)\wedge\beta} \sigma^j + (n+i-\beta)^+\sigma^\beta.$$

Take $i = 1$ and assume that $\beta \geq 4$. Then, from the above expansion we get

$$\mathbb{E}W^1 = \sigma^1 + \lambda \frac{(\sigma^2)^2}{2} + \lambda^2 \frac{(\sigma^3)^3 - (\sigma^2)^3 + 3\sigma^2(\sigma^3)^2}{6} + \mathcal{O}(\lambda^3)$$

Observe that, in the above expansion of $\mathbb{E}W^i$, the coefficient of the k -th order term depends only on the service times $\sigma^2, \sigma^3, \dots, \sigma^{k+i}$ of the first $k+i$ servers. In particular, this coefficient does not depend on β provided that the total number of queues is sufficiently large.

What about Blocking Before Service? Consider a system of $\beta = 5$ single-server FIFO queues in tandem with “blocking before service”, i.e. in each station, a customer can only start its service whenever the downstream station is empty (this is also called *communication blocking*). The Petri net description is given in Figure 4. The places of type p_1 represent the recycling of the servers. With server i a sequence of random variables σ_n^i is associated indicating the successive service times there. The places of type p_2 represent the servers and the places of type p_3 are used to enforce the blocking. Notice that the number of tokens in circuits containing places of types p_2 and p_3 represents the maximal capacity for each station (in service and in the queue), which is 1 in this example. Let σ^i be the (deterministic) service time in

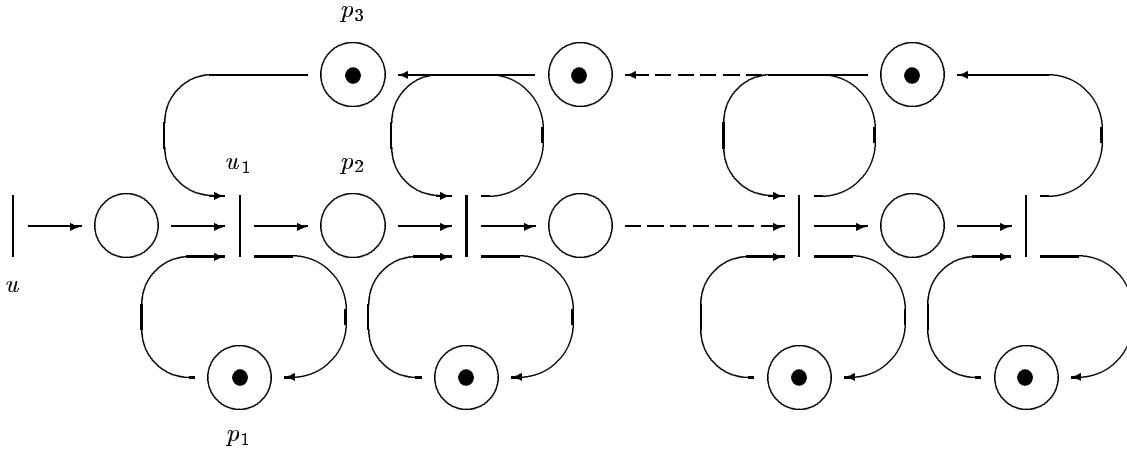

Figure 4: Blocking Before Service

station $i \in \{1, \dots, 5\}$. We assume that $\sigma_1 \leq \sigma_2 \leq \dots \leq \sigma_5$. Then, for x_n^i defined as the time when the service of customer n is started in station i , the framework of Section 4.1 applies with

$$A_0(n) = \begin{pmatrix} \varepsilon & \varepsilon & \varepsilon & \varepsilon & \varepsilon \\ 1 & \varepsilon & \varepsilon & \varepsilon & \varepsilon \\ \varepsilon & 2 & \varepsilon & \varepsilon & \varepsilon \\ \varepsilon & \varepsilon & 3 & \varepsilon & \varepsilon \\ \varepsilon & \varepsilon & \varepsilon & 4 & \varepsilon \end{pmatrix}, \quad A_1(n) = \begin{pmatrix} 1 & 2 & \varepsilon & \varepsilon & \varepsilon \\ \varepsilon & 2 & 3 & \varepsilon & \varepsilon \\ \varepsilon & \varepsilon & 3 & 4 & \varepsilon \\ \varepsilon & \varepsilon & \varepsilon & 4 & 5 \\ \varepsilon & \varepsilon & \varepsilon & \varepsilon & 5 \end{pmatrix}, \quad B_0(n) = \begin{pmatrix} 0 \\ \varepsilon \\ \varepsilon \\ \varepsilon \\ \varepsilon \end{pmatrix}.$$

and so

$$A = A_0^*(0) \otimes A_1(0) = \begin{pmatrix} 1 & 2 & \varepsilon & \varepsilon & \varepsilon \\ 1^2 & 12 & 3 & \varepsilon & \varepsilon \\ 1^2 2 & 12^2 & 23 & 4 & \varepsilon \\ 1^2 2 3 & 12^2 3 & 23^2 & 34 & 5 \\ 1^2 2 3 4 & 12^2 3 4 & 23^2 4 & 34^2 & 45 \end{pmatrix}, \quad B = A_0^*(0) \otimes B_0(0) = \begin{pmatrix} 0 \\ 1 \\ 12 \\ 123 \\ 1234 \end{pmatrix}.$$

Finally, for the matrices D_n defined in (10), we have with the notation $\gamma = \sigma^4 + \sigma^5 = 45$:

$$D_0 = \begin{pmatrix} 0 \\ 1 \\ 12 \\ 123 \\ 1234 \end{pmatrix}, \quad D_1 = \begin{pmatrix} 12 \\ 123 \\ 1234 \\ 123\gamma \\ 1234\gamma \end{pmatrix}, \quad D_2 = \begin{pmatrix} 12^23 \\ 123^24 \\ 1234\gamma \\ 123\gamma^2 \\ 1234\gamma^2 \end{pmatrix}, \quad D_3 = \begin{pmatrix} 12^23^24 \\ 123^24\gamma \\ 1234\gamma^2 \\ 123\gamma^3 \\ 1234\gamma^3 \end{pmatrix}, \quad (55)$$

and for $n \geq 4$:

$$D_n = \begin{pmatrix} 12^23^24\gamma^{n-3} \\ 123^24\gamma^{n-2} \\ 1234\gamma^{n-1} \\ 123\gamma^n \\ 1234\gamma^n \end{pmatrix}. \quad (56)$$

Using the same type of techniques as in the previous example, we obtain the following expansion for the waiting time W^1 in the first buffer:

$$\begin{aligned} \mathbb{E}W^1 &= \frac{\lambda}{2}(\sigma^1 + \sigma^2)^2 \\ &+ \frac{\lambda^2}{6} [(\sigma^1 + \sigma^2)^3 + (\sigma^1 + 2\sigma^2 + \sigma^3)^3 - 3(\sigma^1 + \sigma^2)^2(\sigma^1 + 2\sigma^2 + \sigma^3)] \\ &+ \mathcal{O}(\lambda^3). \end{aligned}$$

4.2.4 Kanban System

Let us consider the Kanban system with two stages given in Figure 5. For more details on this type of manufacturing systems, see [16]. Let us just mention that kanban lines describe ways to operate multistage production lines, and that each stage describes the environment of one machine. In this picture, stage 1 corresponds to the set of places p_1 to p_5 : place p_1 is the input buffer of the machine of stage 1, place p_2 is the machine itself (the cycle containing places p_2 and p_4 being present to translate the fact that only one object can be manufactured by machine 1 at a given time) and place p_3 represents the output buffer of machine 1. The cycle which contains place p_5 translates the maximum total buffer capacity within stage one. For this example, this total capacity is 2 (i.e. the total number of objects in the environment of machine 1, be it in the input buffer, being processed by the machine or in the output buffer, is at most 2), which translates into the fact that there are two tokens in place p_5 . As in our previous examples, whenever the total capacity of the downstream stage (corresponding to the environment of machine 2) is reached, no object can move from the output buffer of machine 1 (p_3) to the input buffer of machine 2.

In this example, the only non-zero firing times in stage 1 are those associated with the transition which precedes place p_2 , and we will denote σ_n^1 the duration of its n -th firing (with a similar notation for the corresponding transition of stage 2). Of course, this firing time is just the manufacturing time of the n -th object manufactured by machine i . We have added loops on all transitions in order to fulfil our assumption on diagonal terms of the A matrices. Adding them is of no importance since all other transitions have deterministic firing times all equal to 0. So we have a stochastic event graph with $\beta = 7$ internal transitions and $M = 2$. By numbering the transitions from 1 to 7 from left to right (excluding

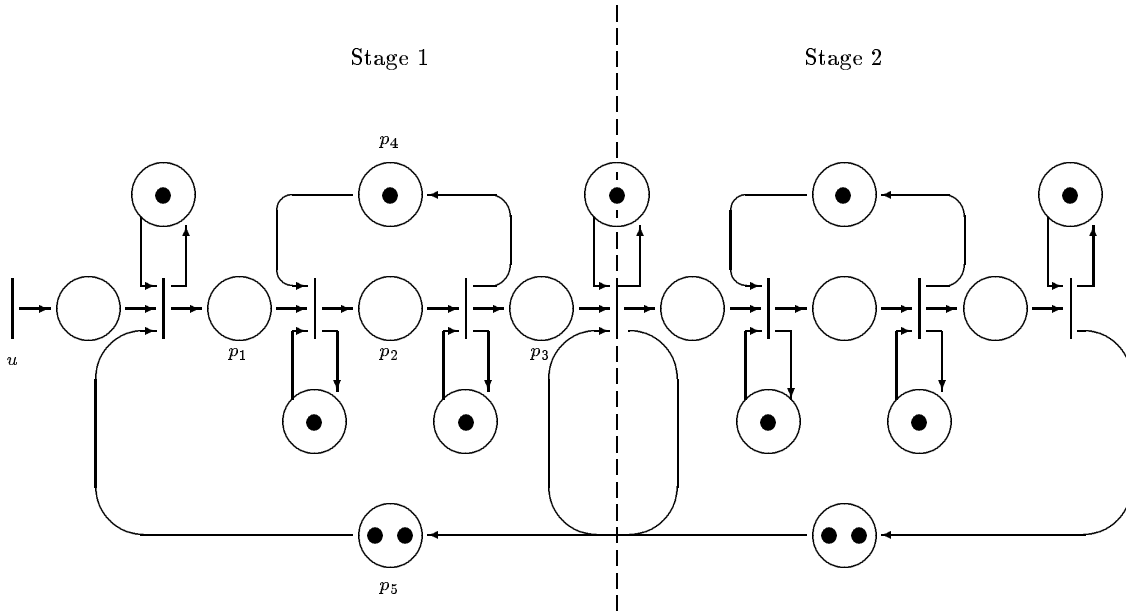

Figure 5: A Two Stage Kanban

u), we obtain the following characteristics for $x_n = (x_n^1, \dots, x_n^7)$:

$$A_0(n) = \begin{pmatrix} \varepsilon & \varepsilon & \varepsilon & \varepsilon & \varepsilon & \varepsilon & \varepsilon \\ 0 & \varepsilon & \varepsilon & \varepsilon & \varepsilon & \varepsilon & \varepsilon \\ \varepsilon & \sigma_n^1 & \varepsilon & \varepsilon & \varepsilon & \varepsilon & \varepsilon \\ \varepsilon & \varepsilon & 0 & \varepsilon & \varepsilon & \varepsilon & \varepsilon \\ \varepsilon & \varepsilon & \varepsilon & 0 & \varepsilon & \varepsilon & \varepsilon \\ \varepsilon & \varepsilon & \varepsilon & \varepsilon & \sigma_n^2 & \varepsilon & \varepsilon \\ \varepsilon & \varepsilon & \varepsilon & \varepsilon & \varepsilon & 0 & \varepsilon \end{pmatrix}, \quad A_1(n) = \begin{pmatrix} 0 & \varepsilon & \varepsilon & \varepsilon & \varepsilon & \varepsilon & \varepsilon \\ \varepsilon & \sigma_{n-1}^1 & 0 & \varepsilon & \varepsilon & \varepsilon & \varepsilon \\ \varepsilon & \varepsilon & 0 & \varepsilon & \varepsilon & \varepsilon & \varepsilon \\ \varepsilon & \varepsilon & \varepsilon & 0 & \varepsilon & \varepsilon & \varepsilon \\ \varepsilon & \varepsilon & \varepsilon & \varepsilon & \sigma_{n-1}^2 & 0 & \varepsilon \\ \varepsilon & \varepsilon & \varepsilon & \varepsilon & \varepsilon & 0 & \varepsilon \\ \varepsilon & \varepsilon & \varepsilon & \varepsilon & \varepsilon & \varepsilon & 0 \end{pmatrix},$$

and

$$A_2(n) = \begin{pmatrix} \varepsilon & \varepsilon & \varepsilon & 0 & \varepsilon & \varepsilon & \varepsilon \\ \varepsilon & \varepsilon & \varepsilon & \varepsilon & \varepsilon & \varepsilon & \varepsilon \\ \varepsilon & \varepsilon & \varepsilon & \varepsilon & \varepsilon & \varepsilon & \varepsilon \\ \varepsilon & \varepsilon & \varepsilon & \varepsilon & \varepsilon & \varepsilon & 0 \\ \varepsilon & \varepsilon & \varepsilon & \varepsilon & \varepsilon & \varepsilon & \varepsilon \\ \varepsilon & \varepsilon & \varepsilon & \varepsilon & \varepsilon & \varepsilon & \varepsilon \\ \varepsilon & \varepsilon & \varepsilon & \varepsilon & \varepsilon & \varepsilon & \varepsilon \end{pmatrix}, \quad B_0(n) = \begin{pmatrix} 0 \\ \varepsilon \\ \varepsilon \\ \varepsilon \\ \varepsilon \\ \varepsilon \\ \varepsilon \end{pmatrix}.$$

We can easily reduce the dimension by eliminating the variables x^2 and x^5 , considering only the vector $x'_n = (x_n^1, x_n^3, x_n^4, x_n^6, x_n^7)$. The elimination of x^2 goes as follows, departing from the initial 7-dimensional

system:

$$\begin{aligned}
x_n^1 &= x_{n-1}^1 \oplus x_{n-2}^4 \oplus u_n \\
x_n^2 &= x_n^1 \oplus (x_{n-1}^2 \otimes \sigma_{n-1}^1) \oplus x_{n-1}^3 \\
x_n^3 &= (x_n^2 \otimes \sigma_n^1) \oplus x_{n-1}^3 \\
x_n^4 &= x_n^3 \oplus x_{n-1}^4 \oplus x_{n-2}^7 \\
x_n^5 &= x_n^4 \oplus (x_{n-1}^5 \otimes \sigma_{n-1}^2) \oplus x_{n-1}^6 \\
x_n^6 &= (x_n^5 \otimes \sigma_n^2) \oplus x_{n-1}^6 \\
x_n^7 &= x_n^6 \oplus x_{n-1}^7
\end{aligned} \tag{57}$$

Using the second line of (57), we get

$$\begin{aligned}
x_n^3 &= (x_n^1 \otimes \sigma_n^1) \oplus (x_{n-1}^2 \otimes \sigma_{n-1}^1 \otimes \sigma_n^1) \oplus (x_{n-1}^3 \otimes \sigma_n^1) \oplus x_{n-1}^3 \\
&= (x_n^1 \otimes \sigma_n^1) \oplus (x_{n-1}^2 \otimes \sigma_{n-1}^1 \otimes \sigma_n^1) \oplus (x_{n-1}^3 \otimes \sigma_n^1) \\
&= (x_n^1 \otimes \sigma_n^1) \oplus (x_{n-1}^3 \otimes \sigma_n^1),
\end{aligned}$$

where the reason for the last equality is that due the third line of (57), i.e.

$$x_{n-1}^3 \geq x_{n-1}^2 \otimes \sigma_{n-1}^1$$

and therefore

$$x_{n-1}^3 \otimes \sigma_n^1 \geq x_{n-1}^2 \otimes \sigma_{n-1}^1 \otimes \sigma_n^1.$$

The elimination of x^5 is similar.

The reduced vector $x'_n = (x_n^1, x_n^3, x_n^4, x_n^6, x_n^7)$ satisfies the same recursion of order 2, but with the 5-dimensional matrices:

$$\tilde{A}_0(n) = \begin{pmatrix} \varepsilon & \varepsilon & \varepsilon & \varepsilon & \varepsilon \\ \sigma_n^1 & \varepsilon & \varepsilon & \varepsilon & \varepsilon \\ \varepsilon & 0 & \varepsilon & \varepsilon & \varepsilon \\ \varepsilon & \varepsilon & \sigma_n^2 & \varepsilon & \varepsilon \\ \varepsilon & \varepsilon & \varepsilon & 0 & \varepsilon \end{pmatrix}, \quad \tilde{A}_1(n) = \begin{pmatrix} 0 & \varepsilon & \varepsilon & \varepsilon & \varepsilon \\ \varepsilon & \sigma_n^1 & \varepsilon & \varepsilon & \varepsilon \\ \varepsilon & \varepsilon & 0 & \varepsilon & \varepsilon \\ \varepsilon & \varepsilon & \varepsilon & \sigma_n^2 & \varepsilon \\ \varepsilon & \varepsilon & \varepsilon & \varepsilon & 0 \end{pmatrix},$$

and

$$\tilde{A}_2(n) = \begin{pmatrix} \varepsilon & \varepsilon & 0 & \varepsilon & \varepsilon \\ \varepsilon & \varepsilon & \varepsilon & \varepsilon & \varepsilon \\ \varepsilon & \varepsilon & \varepsilon & \varepsilon & 0 \\ \varepsilon & \varepsilon & \varepsilon & \varepsilon & \varepsilon \\ \varepsilon & \varepsilon & \varepsilon & \varepsilon & \varepsilon \end{pmatrix}, \quad \tilde{B}_0(n) = \begin{pmatrix} 0 \\ \varepsilon \\ \varepsilon \\ \varepsilon \\ \varepsilon \end{pmatrix}.$$

In this reduced dimension, the $A_0^*(n)$ matrix (we drop the \sim from now on, as we will only work with the 5-dimensional system) is given by:

$$A_0^*(n) = \begin{pmatrix} 0 & \varepsilon & \varepsilon & \varepsilon & \varepsilon \\ \sigma_n^1 & 0 & \varepsilon & \varepsilon & \varepsilon \\ \sigma_n^1 & 0 & 0 & \varepsilon & \varepsilon \\ \sigma_n^1 + \sigma_n^2 & \sigma_n^2 & \sigma_n^2 & 0 & \varepsilon \\ \sigma_n^1 + \sigma_n^2 & \sigma_n^2 & \sigma_n^2 & 0 & 0 \end{pmatrix}.$$

From this, we can compute the matrices $\overline{A}_1(n)$ and $\overline{A}_2(n)$ and the vector $\overline{B}_0(n)$:

$$\overline{A}_1(n) = \begin{pmatrix} 0 & \varepsilon & \varepsilon & \varepsilon & \varepsilon \\ \sigma_n^1 & \sigma_n^1 & \varepsilon & \varepsilon & \varepsilon \\ \sigma_n^1 & \sigma_n^1 & 0 & \varepsilon & \varepsilon \\ \sigma_n^1 + \sigma_n^2 & \sigma_n^1 + \sigma_n^2 & \sigma_n^2 & \sigma_n^2 & \varepsilon \\ \sigma_n^1 + \sigma_n^2 & \sigma_n^1 + \sigma_n^2 & \sigma_n^2 & \sigma_n^2 & 0 \end{pmatrix},$$

$$\overline{A}_2(n) = \begin{pmatrix} \varepsilon & \varepsilon & 0 & \varepsilon & \varepsilon \\ \varepsilon & \varepsilon & \sigma_n^1 & \varepsilon & \varepsilon \\ \varepsilon & \varepsilon & \sigma_n^1 & \varepsilon & 0 \\ \varepsilon & \varepsilon & \sigma_n^1 + \sigma_n^2 & \varepsilon & \sigma_n^2 \\ \varepsilon & \varepsilon & \sigma_n^1 + \sigma_n^2 & \varepsilon & \sigma_n^2 \end{pmatrix}, \quad \overline{B}_0(n) = \begin{pmatrix} 0 \\ \sigma_n^1 \\ \sigma_n^1 \\ \sigma_n^1 + \sigma_n^2 \\ \sigma_n^1 + \sigma_n^2 \end{pmatrix}.$$

So, the matrix A_n is given by:

$$A_n = \begin{pmatrix} 0 & \varepsilon & \varepsilon & \varepsilon & \varepsilon & \varepsilon & \varepsilon & 0 & \varepsilon & \varepsilon \\ \sigma_{n+1}^1 & \sigma_{n+1}^1 & \varepsilon & \varepsilon & \varepsilon & \varepsilon & \varepsilon & \sigma_{n+1}^1 & \varepsilon & \varepsilon \\ \sigma_{n+1}^1 & \sigma_{n+1}^1 & 0 & \varepsilon & \varepsilon & \varepsilon & \varepsilon & \sigma_{n+1}^1 & \varepsilon & 0 \\ \sigma_{n+1}^1 + \sigma_{n+1}^2 & \sigma_{n+1}^1 + \sigma_{n+1}^2 & \sigma_{n+1}^2 & \sigma_{n+1}^2 & \varepsilon & \varepsilon & \varepsilon & \sigma_{n+1}^1 + \sigma_{n+1}^2 & \varepsilon & \sigma_{n+1}^2 \\ \sigma_{n+1}^1 + \sigma_{n+1}^2 & \sigma_{n+1}^1 + \sigma_{n+1}^2 & \sigma_{n+1}^2 & \sigma_{n+1}^2 & 0 & \varepsilon & \varepsilon & \sigma_{n+1}^1 + \sigma_{n+1}^2 & \varepsilon & \sigma_{n+1}^2 \\ 0 & \varepsilon & \varepsilon & \varepsilon & \varepsilon & 0 & \varepsilon & \varepsilon & \varepsilon & \varepsilon \\ \varepsilon & 0 & \varepsilon & \varepsilon & \varepsilon & 0 & \varepsilon & \varepsilon & \varepsilon & \varepsilon \\ \varepsilon & \varepsilon & 0 & \varepsilon & \varepsilon & \varepsilon & \varepsilon & 0 & \varepsilon & \varepsilon \\ \varepsilon & \varepsilon & \varepsilon & 0 & \varepsilon & \varepsilon & \varepsilon & \varepsilon & 0 & \varepsilon \\ \varepsilon & \varepsilon & \varepsilon & \varepsilon & 0 & \varepsilon & \varepsilon & \varepsilon & \varepsilon & 0 \end{pmatrix}.$$

From this, we obtain the following expressions:

$$\begin{aligned} D_0^1 &= 0 \\ D_0^2 &= D_0^3 = \sigma_0^1 \\ D_0^4 &= D_0^5 = \sigma_0^1 + \sigma_0^2 \\ \\ D_1^1 &= 0 \\ D_1^2 &= D_1^3 = \sigma_{-1}^1 + \sigma_0^1 \\ D_1^4 &= D_1^5 = \max\{\sigma_{-1}^1 + \sigma_0^1 + \sigma_0^2, \sigma_{-1}^1 + \sigma_{-1}^2 + \sigma_0^2\} \\ \\ D_2^1 &= \sigma_{-2}^1 \\ D_2^2 &= \sigma_{-2}^1 + \sigma_{-1}^1 + \sigma_0^1 \\ D_2^3 &= \max\{\sigma_{-2}^1 + \sigma_{-1}^1 + \sigma_0^1, \sigma_{-2}^1 + \sigma_{-2}^2\} \\ D_2^4 &= D_2^5 = \max\{\sigma_{-2}^1 + \sigma_{-1}^1 + \sigma_0^1 + \sigma_0^2, \sigma_{-2}^1 + \sigma_{-1}^1 + \sigma_{-1}^2 + \sigma_0^2, \\ &\quad \sigma_{-2}^1 + \sigma_{-2}^2 + \sigma_{-1}^2 + \sigma_0^2\} \end{aligned}$$

Expansions – Deterministic Case Consider the deterministic case. From what precedes, $D_0^5 = \sigma^1 + \sigma^2$, $D_1^5 = D_0^5 + \max\{\sigma^1, \sigma^2\}$ and $D_2^5 = D_1^5 + \max\{\sigma^1, \sigma^2\}$. So, we obtain the following expansion for the stationary total system time S , which coincides with coordinate W^7 of the 7-dimensional system, or equivalently to W^5 of the 5-dimensional one:

$$\mathbb{E}S = \sigma^1 + \sigma^2 + \lambda \frac{[\max\{\sigma^1, \sigma^2\}]^2}{2} + \lambda^2 \frac{[\max\{\sigma^1, \sigma^2\}]^3}{2} + \mathcal{O}(\lambda^3), \quad (58)$$

under the stability condition $\rho < 1$ of Theorem 1 which is here $\lambda \max\{\sigma^1, \sigma^2\} < 1$.

Expansions – Stochastic Case Consider the time which elapses between the arrival of an object and the time it leaves machine 1, that is variable W^3 of the 5-dimensional system. From what precedes, whenever the system is stable and under the assumption that the random variables σ_n^1 and σ_n^2 , with distribution functions G_1 and G_2 respectively, are independent and have moments of order 5, we obtain:

$$\mathbb{E}W^3 = \mathbb{E}[\sigma^1] + \lambda \frac{c_1}{2} + \lambda^2 \frac{c_2}{6} + \mathcal{O}(\lambda^3). \quad (59)$$

The coefficients are given by the following integrals:

$$c_1 = \int_{\mathbf{R}_+} x^2 G_1(dx) \quad (60)$$

an expression which does not depend on G_2 , whereas

$$c_2 = \int_{\mathbf{R}_+^4} h(x_0, x_1, x_2, y) G_1(dx_0) G_1(dx_1) G_1(dx_2) G_2(dy) \quad (61)$$

with

$$h(x_0, x_1, x_2, y) = x_1^3 + (\max\{x_1 + x_2, x_2 + y - x_0\})^3 - 3x_1^3 \max\{x_1 + x_2, x_2 + y - x_0\}.$$

A similar expansion can be derived for S , involving a 6-dimensional integral for the computation of the coefficient of λ^2 etc.

4.3 Remarks on the computation of the coefficients

As we have seen, the computation of the coefficients reduce to the computation of certain d -dimensional integrals such as (61), for instance.

In case of exponentially distributed firing times (or more generally of firing times with rational Laplace transforms, such integrals can always be reduced to the integration of polynomial-exponential functions (functions involving products of two types of functions:

- exponentials of linear functions of x_0, x_1, \dots
- polynomials in x_0, x_1, \dots)

over polyhedrons, which leads to closed form expressions.

5 Factorial Moment Expansion

In order to prove the Taylor-series expansion stated in Section 3.1, we will use a general idea which consists in expanding the expectation of vector-valued functionals of marked point processes. More precisely, we use a formula which expresses this expectation by a sum of integrals of much simpler functionals w.r.t. higher-order factorial moment measures of the underlying point process, with a remainder term which is the integral of a functional with respect to a higher-order Palm measure. For univariate (non-marked) point processes, this concept has been developed in [9] starting from a corresponding first-order expansion obtained in [3]. Related higher-order expansions for functionals of independently marked Poisson processes have been considered in [20, 26, 29], and for more general marked point processes in [10, 12], see also the survey given in [13]. In the present paper we will concentrate on higher-order expansions for the expectation of vector-valued functionals of weakly independently marked Poisson processes.

5.1 Expansion Kernels

For any given natural number α , let ψ be an \mathbb{R}^α -valued functional of a marked point process, i.e. a measurable mapping $\psi : \mathcal{M} \times \mathcal{K}^\infty \rightarrow \mathbb{R}^\alpha$, where \mathcal{M} is the space of all realizations of the point process $\{T_n\}$ and \mathcal{K}^∞ is the space of all sequences $Z = \{Z_n\}$ of potential marks. We assume that the *mark space* \mathcal{K} is a complete separable metric space. Note that the sequence $\{T_n\}$ of points may be infinite, finite or empty, whereas the sequence $Z = \{Z_n\}$ of potential marks is always two-sided infinite. Let Z_n denote the mark of point T_n .

Like in Section 2.1, we represent a realization $\{t_n\}$ of the point process $\{T_n\}$ by the counting measure $\mu = \sum_n \delta_{t_n}$. Then, \mathcal{M} is the set of all counting measures μ which are locally finite and such that $\mu(\{s\})$ is either 0 or 1 for all $s \in \mathbb{R}$. By o we denote the null measure, representing an input with no arrivals (i.e. $o(\mathbb{R}) = 0$).

For every $s \in \mathbb{R}$, let the restriction $\mu|_s$ of $\mu \in \mathcal{F}$ be defined by

$$\mu|_s(D) = \mu(D \cap (s, \infty)).$$

Furthermore, for any $s \in \mathbb{R}$ and $z \in \mathcal{K}^\infty$, let

$$\psi_s(\mu, z) = \psi(\mu|_s + \delta_s, z) - \psi(\mu|_s, z). \quad (62)$$

Let $k \geq 1$ be an arbitrary, but fixed integer. For any $s_1, \dots, s_k \in \mathbb{R}$, let ψ_{s_1, \dots, s_k} be defined by iteration of the mapping $\psi \rightarrow \psi_s$, i.e.

$$\psi_{s_1, \dots, s_k}(\mu, z) = (\dots (\psi_{s_1})_{s_2} \dots)_{s_k}(\mu, z).$$

Note that the functional ψ_{s_1, \dots, s_k} can be written in the form

$$\psi_{s_1, \dots, s_k}(\mu, z) = \begin{cases} \sum_{j=0}^k (-1)^{k-j} \sum_{\pi \in K_{k,j}} \psi(\mu|_{s_k} + \sum_{i \in \pi} \delta_{s_i}, z) & \text{for } s_k < \dots < s_1 \\ 0 & \text{otherwise,} \end{cases} \quad (63)$$

where $K_{k,j}$ denotes the collection of all the subsets of $\{1, \dots, k\}$ containing j elements. Following [9], we call the functional ψ *continuous at infinities* if

$$\lim_{s \rightarrow \infty} \psi(\mu|_s + \nu, z) = \psi(\nu, z), \quad \lim_{s \rightarrow -\infty} \psi(\mu|_s, z) = \psi(\mu, z) \quad (64)$$

for all $\mu, \nu \in \mathcal{M}$, $z \in \mathcal{K}^\infty$ with $\nu(\mathbb{R}) < \infty$.

5.2 General Representation Formula

For the stationary Poisson process $\{T_n\}$ with intensity λ , and for the stationary sequence $Z = \{Z_n\}$ of \mathcal{K} -valued random variables which is independent of $\{T_n\}$, let P_λ denote the distribution of $\{T_n\}$, and Q the distribution of Z .

A slight variant of the following result is given in [26].

Theorem 5 *Let $m \geq 1$ be a fixed integer. If the functional ψ is continuous at infinities, if*

$$\int_{\mathbf{R}^m} \int_{\mathcal{K}^\infty} \int_{\mathcal{M}} |\psi_{s_1, \dots, s_k}^i(\mu, z)| P_\lambda(d\mu) Q(dz) ds_1 \dots ds_k < \infty, \quad (65)$$

for all $k = 1, \dots, m$, and if

$$\limsup_{\lambda \rightarrow 0} \int_{\mathbf{R}^{m+1}} \int_{\mathcal{K}^\infty} \int_{\mathcal{M}} |\psi_{s_1, \dots, s_{m+1}}^i(\mu, z)| P_\lambda(d\mu) Q(dz) ds_1 \dots ds_{m+1} < \infty, \quad (66)$$

for the i -th component ψ^i of ψ , then

$$\mathbb{E}\psi^i(\{T_n, Z_n\}) = \mathbb{E}\psi^i(o, \{Z_n\}) + \sum_{k=1}^m \lambda^k \int_{\mathbf{R}^k} \mathbb{E}\psi_{s_1, \dots, s_k}^i(o, \{Z_n\}) ds_1 \dots ds_k + \mathcal{O}(\lambda^{m+1}). \quad (67)$$

5.3 Expansion of $\mathbb{E}W^i$

In this section we return to the stationary state variable W given in (9) assuming again that the stationary sequence $\{Z_n\} = \{A_n, B_n\}$ of random matrices possesses the monotonicity, boundedness and independence properties formulated in Sections 3.1 and 3.2. This means in particular that $\{T_n, A_n, B_n\}$ is a so-called *weakly independently marked* Poisson process where the mark space \mathcal{K} is the product of two matrix spaces (of $\alpha \times \alpha$ and $\alpha \times 1$ dimensional matrices, respectively). Our goal is to use Theorem 5 in order to show that an expansion of $\mathbb{E}W^i$ of the form (17) exists. For doing this we consider the following functional ψ given by

$$\psi(\mu, z) = b_0 \oplus \bigoplus_{n=1}^{\mu((-\infty, 0))} a_{-1} \otimes \dots \otimes a_{-n} \otimes C(-t_{-n}) \otimes b_{-n} \quad (68)$$

where $\mu = \sum_n \delta_{t_n}$ and $z = \{a_n, b_n\}$, where a_n and b_n denote the realizations of the random matrices A_n and B_n , respectively.

Integrability First we show that the expectation $\mathbb{E}W^i$ exists for each $i \in \{1, \dots, \alpha'\}$. This follows from a corresponding result for the expectation of the maximum of a random walk with negative drift.

Choose r large enough for the conditions of Lemma 1 to hold, and such that the H_n defined in (15) form a sequence of 1-dependent random variables. By

$$h_n = \max_i \left\{ \left(a_{-(rn+1)} \otimes a_{-(rn+2)} \otimes \dots \otimes a_{-r(n+1)} \otimes (b_{-r(n+1)} \oplus O) \right)^i \right\} \quad (69)$$

we denote the realizations of H_n . Using (68) and the monotonicity assumption on the sequence D_n^i , we obtain the bound:

$$\begin{aligned} \psi^i(\mu, z) &\leq \max_i \{b_0^i\} + \sup_{n \geq 0} \{(h_0 + \dots + h_n) + t_{-(rn+1)}\}^+ \\ &\leq \max_i \{b_0^i\} + h_0 + \sup_{n \geq 1} \left\{ \sum_{k=1}^n (h_k + (t_{-(rk+1)} - t_{-(r(k-1)+1)})) \right\}^+ \\ &\leq \max_i \{b_0^i\} + \varphi(\mu, z), \end{aligned} \quad (70)$$

where

$$\begin{aligned} \varphi(\mu, z) &= h_0 + \sup_{n \geq 1} \left\{ \sum_{k=1}^n (h_{2k} + (t_{-(r2k+1)} - t_{-(r(2k-1)+1)})) \right\}^+ \\ &\quad + \sup_{n \geq 1} \left\{ \sum_{k=1}^n (h_{2k-1} + (t_{-(r(2k-1)+1)} - t_{-(r(2k-2)+1)})) \right\}^+. \end{aligned} \quad (71)$$

Because $\{H_n\}$ is a sequence of 1-dependent random variables, the random variables H_2, H_4, \dots are i.i.d. and independent of the i.i.d. random variables $-(T_{-(2r+1)} - T_{-(r+1)}), -(T_{-(4r+1)} - T_{-(3r+1)}), \dots$ which are Erlang distributed with expectation $r \cdot \lambda^{-1}$. Since the sequences H_1, H_3, \dots and $-(T_{-(r+1)} - T_{-1}), -(T_{-(3r+1)} - T_{-(2r+1)}), \dots$ have the same properties, the finiteness of $\mathbb{E}W^i$ now follows from the well-known fact that, under (14), the random walks the realizations of which are considered in (71) have negative drifts and, under (16), the expectations of their maxima are finite (see e.g. Theorem VIII.2.1 in [1]).

Conditions for the Expansion It is easily checked that the functional ψ given by (68) is a.s. continuous at infinities whenever $\rho < 1$. We now show that the conditions (65) and (66) are fulfilled. Let us first prove that (65) holds for $k = 1$. For all $l \in \{0, 1, \dots\}$ and $s \in [t_{-(l+1)}, t_{-l}]$ we have

$$\psi(\mu^s, z) = b_0 \oplus \bigoplus_{n=1}^l a_{-1} \otimes \dots \otimes a_{-n} \otimes C(-t_{-n}) \otimes b_{-n}$$

and

$$\psi(\mu^s + \delta_s, z) = b_0 \oplus \bigoplus_{n=1}^l a_{-1} \otimes \dots \otimes a_{-n} \otimes C(-t_{-n}) \otimes b_{-n} \oplus a_{-1} \otimes \dots \otimes a_{-(l+1)} \otimes C(-s) \otimes b_{-(l+1)}.$$

Thus,

$$\begin{aligned} |\psi_s^i(\mu, z)| &\leq \left(b_0 \oplus a_{-1} \otimes b_{-1} \oplus \bigoplus_{n=2}^{\infty} a_{-1} \otimes \dots \otimes a_{-n} \otimes C(-t_{-(n-1)}) \otimes b_{-n} \right)^i \\ &\quad \times \mathbf{1} \left((a_{-1} \otimes \dots \otimes a_{-(l+1)} \otimes C(-t_{-l}) \otimes b_{-(l+1)})^i > 0 \right) \\ &\leq \left[\max_i \{b_0^i + (a_{-1} \otimes b_{-1})^i\} + \max_{i,j} \{(a_{-1})_{i,j}\} + \varphi(\mu, z \circ \theta) \right] \\ &\quad \times \mathbf{1} \left((a_{-1} \otimes \dots \otimes a_{-(l+1)} \otimes C(-t_{-l}) \otimes b_{-(l+1)})^i > 0 \right). \end{aligned} \quad (72)$$

where $\varphi(\mu, z)$ was defined in (71). Let

$$\begin{aligned} \eta(\mu, z) &= \sup_{n \geq 1} \left\{ -t_{-(r2n+1)} : \sum_{k=1}^n h_{2k} + (t_{-(r2k+1)} - t_{-(r(2k-1)+1)}) > 0 \right\} \\ &\quad + \sup_{n \geq 1} \left\{ -t_{-(r(2n-1)+1)} : \sum_{k=1}^n h_{2k-1} + (t_{-(r(2k-1)+1)} - t_{-(r(2k-2)+1)}) > 0 \right\}. \end{aligned}$$

We assumed that l is such that $s \in [t_{-(l+1)}, t_{-l}]$; let n be such that $nr \leq l \leq (n+1)r$. We can derive an upper bound on the last factor of (72) by using the following inclusions:

$$\begin{aligned} &\{(\mu, z) : (a_{-1} \otimes \dots \otimes a_{-(l+1)} \otimes b_{-(l+1)})^i + t_{-l} > 0\} \\ &\subseteq \{(\mu, z) : (a_{-1} \otimes \dots \otimes a_{-(n+1)r+1} \otimes b_{-(n+1)r+1})^i + t_{-(rn+1)} > 0\} \\ &\subseteq \left\{ (\mu, z) : \max_{i,j} \{(a_{-1})_{i,j}\} + \{(h_0 \circ \theta + \dots + h_n \circ \theta) + t_{-(rn+1)}\} > 0 \right\} \\ &\subseteq \left\{ (\mu, z) : s < \sup_{s \geq 0} \{ -t_{-((k+1)r+1)} : \max_{i,j} \{(a_{-1})_{i,j}\} \right. \\ &\quad \left. + \{(h_0 \circ \theta + \dots + h_k \circ \theta) + t_{-(rk+1)}\} > 0 \} \right\} \\ &\subseteq \left\{ (\mu, z) : \max_{i,j} \{(a_{-1})_{i,j}\} + h_0(z \circ \theta) + \eta(\mu, z \circ \theta) > -s \right\}. \end{aligned}$$

So, we have

$$\begin{aligned} |\psi_s^i(\mu, z)| &\leq \left[\max_i \{b_0^i + (a_{-1} \otimes b_{-1})^i\} + \max_{i,j} \{(a_{-1})_{i,j}\} + \varphi(\mu, z \circ \theta) \right] \\ &\quad \times \mathbf{1} \left(\max_{i,j} \{(a_{-1})_{i,j}\} + h_0(z \circ \theta) + \eta(\mu, z \circ \theta) > -s \right). \end{aligned}$$

Note that the first term in the definition of $\eta(\mu, z)$ has the same form which is that of the realizations of last exit times of certain random walks or, in other words, that of the realizations of the customer-Palm age variable V of the busy period of an $E_r/GI/1$ queue.

Lemma 4 *The q -th moment of V is finite provided that $\mathbb{E}[(H_n)^{q+1}] < \infty$.*

Proof We first prove that V can be bounded in the following way. Let $G(x) = P(T_{-(r+1)} - T_{-(2r+1)} \leq x)$ and let $\tilde{\tau}$ be a random variable with distribution function $\tilde{G}(x)$ given by

$$\tilde{G}(x) = \frac{\int_0^x (1 - G(u)) du}{\int_0^\infty (1 - G(u)) du}.$$

Because $T_{-(r+1)} - T_{-(2r+1)}$ is Erlang distributed, we have $G(x) \leq \tilde{G}(x)$ for all x . This means that we can assume that $T_{-(r+1)} - T_{-(2r+1)} \geq \tilde{\tau}$ with probability one. Thus

$$\begin{aligned} V &= \sup \left\{ -T_{-(r2n+1)} : \sum_{k=1}^n H_{2k} + (T_{-(r2k+1)} - T_{-(r(2k-1)+1)}) > 0 \right\} \\ &\leq \sup \left\{ -T_{-(r2n+1)} : H_2 - \tilde{\tau} + \sum_{k=2}^n H_{2k} + (T_{-(r2k+1)} - T_{-(r(2k-1)+1)}) > 0 \right\} \\ &= \tilde{V} + T_{-(2r+1)} + \tilde{\tau}, \end{aligned}$$

where \tilde{V} has the same distribution as the (continuous-time) stationary age variable of the busy period of an $E_r/GI/1$ queue. For $\mathbb{E}\tilde{V}^q < \infty$ to hold, it is enough that the $(q+1)$ -st moment of the Palm distribution (w.r.t. the point process of first points in the busy periods) of the full busy period be finite. But from Corollary 1a of [31], it follows that this is true if $\mathbb{E}[(H_n)^{q+1}] < \infty$. \square

Because the second term of $\eta(\mu, z)$ can be bounded in the same way, we get

$$\mathbb{E}[\eta^q(\{T_n\}, \{Z_n\})] < \infty \quad \text{if} \quad \mathbb{E}[(H_n)^{q+1}] < \infty. \quad (73)$$

Moreover, from Theorem VIII.2.1 in [1] we have

$$\mathbb{E}[\varphi^q(\{T_n\}, \{Z_n\})] < \infty \quad \text{if} \quad \mathbb{E}[(H_n)^{q+1}] < \infty \quad (74)$$

where the mapping φ is given in (71). From the above considerations we get that

$$\begin{aligned} & \mathbb{E} \int_{\mathcal{R}} |\psi_s^i(\{T_n\}, \{Z_n\})| ds \\ & \leq \mathbb{E} \left\{ \left[\max_i \{B_0^i + (A_{-1} \otimes B_{-1})^i\} + \max_{i,j} \{(A_{-1})_{i,j}\} + \varphi(\{T_n\}, \{Z_{n+1}\}) \right] \right. \\ & \quad \left. \times \left[\max_{i,j} \{(A_{-1})_{i,j}\} + H_0(\{Z_{n+1}\}) + \eta(\{T_n\}, \{Z_{n+1}\}) \right] \right\} \\ & \leq 3\mathbb{E} \left\{ \left[\max_i \{B_0^i + (A_{-1} \otimes B_{-1})^i\} \right]^2 + 2 \left[\max_{i,j} \{(A_{-1})_{i,j}\} \right]^2 \right. \\ & \quad \left. + [\varphi(\{T_n\}, \{Z_{n+1}\})]^2 + [H_0(\{Z_{n+1}\})]^2 + [\eta(\{T_n\}, \{Z_{n+1}\})]^2 \right\}, \end{aligned}$$

where the obvious inequality $xy \leq x^2 + y^2$ was used. Thus, (73) and (74) give that

$$\int_{\mathcal{R}} \int_{\mathcal{K}^\infty} \int_{\mathcal{M}} |\psi_s^i(\mu, z)| P_\lambda(d\mu) Q(dz) ds < \infty$$

provided that $\mathbb{E}[(H_n)^3] < \infty$. By similar arguments, we get that (65) for all $k = 1, \dots, m$ and (66) are fulfilled if $\mathbb{E}[(H_n)^{m+3}] < \infty$, because of the inequality

$$\begin{aligned} |\psi_{s_1, \dots, s_k}^i(\mu, z)| & \leq 2^k \left[\max_i \left\{ b_0^i + \sum_{n=1}^k (a_{-1} \otimes \dots \otimes a_n \otimes b_n)^i \right\} \right. \\ & \quad \left. + \max_{i,j} \{(a_{-1} \otimes \dots \otimes a_{-k})_{i,j}\} + \varphi(\mu, z \circ \theta^k) \right] \\ & \quad \times \left[\prod_{n=1}^k \mathbf{1} \left(\max_{i,j} \{(a_{-1} \otimes \dots \otimes a_{-k})_{i,j}\} + h_0(z \circ \theta^k) + \eta(\mu, z \circ \theta^k) > s_n \right) \right]. \end{aligned}$$

6 Calculation of Coefficients

6.1 Recursion Formula

It turns out that, for the functional ψ given by (68) and under the monotonicity assumption (13), the coefficients of λ^k in the series expansion (67) can be determined recursively. Because of (12), (68) can

be rewritten in the form

$$\psi(\mu, z) = d_0 \oplus \bigoplus_{n=1}^{\mu((-\infty, 0))} C(-t_{-n}) \otimes d_n. \quad (75)$$

where d_0, d_1, \dots denotes the realizations of the sequence of α -dimensional random vectors D_0, D_1, \dots defined in (12), i.e. $d_k = \left(\bigoplus_{n=1}^k a_{-n} \right) \otimes b_{-k}$ whose i -th components d_k^i satisfy

$$d_0^i \leq d_1^i \leq \dots \quad (76)$$

for every $i \in \{1, \dots, \alpha'\}$. This gives

$$\psi^i(\mu, z) = d_0^i \oplus \bigoplus_{n=1}^{\mu((-\infty, 0))} (d_n^i + t_{-n}). \quad (77)$$

Using the notation

$$p_{k+1}(d_0^i, d_1^i, \dots, d_k^i) = \int_{\mathbf{R}^k} \psi_{s_1, \dots, s_k}^i(o, z) ds_1 \dots ds_k, \quad (78)$$

for the coefficients of λ^k in (67) we obtain the following result.

Theorem 6 For each $k \geq 1$ and $i \in \{1, \dots, \alpha'\}$ it holds

$$p_{k+1}(d_0^i, d_1^i, \dots, d_k^i) = \sum_{n=0}^{k-1} \int_{d_n^i - d_0^i}^{d_{n+1}^i - d_0^i} \left[p_k(\underbrace{d_0^i, \dots, d_n^i}_n, d_{n+1}^i - u, \dots, d_k^i - u) \right. \\ \left. - p_k(\underbrace{d_0^i, \dots, d_n^i}_{n+1}, d_{n+1}^i - u, \dots, d_{k-1}^i - u) \right] du. \quad (79)$$

Proof From (63) and (77) we get

$$p_{k+1}(d_0^i, d_1^i, \dots, d_k^i) = \int_0^\infty \int_{s_1}^\infty \dots \int_{s_{k-1}}^\infty \psi_{-s_1, \dots, -s_k}^i(o) ds_k \dots ds_1 \\ = \int_0^\infty \int_{s_1}^\infty \dots \int_{s_{k-1}}^\infty \sum_{l=0}^k (-1)^{k-l} \sum_{\pi \in K_{k,l}} d_0^i \oplus \bigoplus_{j=1}^l (d_j^i - s_{\pi(j)}) ds_k \dots ds_1$$

where $(s_{\pi(1)}, \dots, s_{\pi(l)})$ with $s_{\pi(1)} < \dots < s_{\pi(l)}$ is the subset of those l components selected from (s_1, \dots, s_k) by $\pi \in K_{k,l}$. We decompose the outer integral in the following way:

$$\int_0^\infty \dots = \sum_{n=0}^{k-1} \int_{d_n^i - d_0^i}^{d_{n+1}^i - d_0^i} \dots$$

Next, for each of these summands, we decompose the inner sum:

$$\sum_{\pi \in K_{k,l}} \dots = \sum_{\pi \in K_{k,l}, \pi \ni 1} \dots + \sum_{\pi \in K_{k,l}, \pi \not\ni 1} \dots$$

Furthermore,

$$\begin{aligned} & \int_{d_n^i - d_0^i}^{d_{n+1}^i - d_0^i} \int_{s_1}^\infty \dots \int_{s_{k-1}}^\infty \sum_{l=1}^k (-1)^{k-l} \sum_{\pi \in K_{k,l}, \pi \ni 1} d_0^i \oplus \bigoplus_{j=1}^l (d_j^i - s_{\pi(j)}) ds_k \dots ds_1 \\ &= \int_{d_n^i - d_0^i}^{d_{n+1}^i - d_0^i} \int_{s_1}^\infty \dots \int_{s_{k-1}}^\infty \sum_{l=1}^k (-1)^{k-l} \sum_{\pi \in K_{k,l}, \pi \ni 1} d_0^i \oplus \bigoplus_{j=1}^{\min(n,l)} (d_j^i - s_{\pi(j)}) \\ & \qquad \oplus \bigoplus_{j=\min(n,l)+1}^l (d_j^i - s_{\pi(j)}) ds_k \dots ds_1 \end{aligned}$$

because from $d_n^i - d_0^i \leq s_1$ it follows that

$$d_j^i - s_{\pi(j)} \leq d_j^i - s_1 \leq d_n^i - s_1 \leq d_0^i$$

for all $j \leq \min(n, l)$. By the substitution $s_{\pi(j)} \rightarrow s_{\pi(j)} - s_1$, this gives the plus term in (79). The minus term in (79) follows analogously. \square

6.2 Polynomial Solution

Now we derive the more explicit expression for the coefficients $\mathbb{E}p_{k+1}(D_0^i, D_1^i, \dots, D_k^i)$ of λ^k in the series expansion of $\mathbb{E}W^i$ as stated in Theorem 2. For each non-decreasing sequence x_0, x_1, \dots of non-negative numbers (i.e. $0 \leq x_0 \leq x_1 \leq \dots$) we consider a sequence of numbers

$$p_1(x_0), p_2(x_0, x_1), \dots, p_k(x_0, x_1, \dots, x_{k-1}), \dots$$

which satisfy the following *recursion formula*: Assume that, for each $k = 1, 2, \dots$,

$$\begin{aligned} p_{k+1}(x_0, x_1, \dots, x_k) &= \sum_{n=0}^{k-1} \int_{x_n - x_0}^{x_{n+1} - x_0} [p_k(\underbrace{x_0, \dots, x_0}_n, x_{n+1} - u, \dots, x_k - u) \\ & - p_k(\underbrace{x_0, \dots, x_0}_{n+1}, x_{n+1} - u, \dots, x_{k-1} - u)] du \end{aligned} \tag{80}$$

and that

$$p_1(x_0) = x_0, \quad p_2(x_0, x_1) = \frac{1}{2} [x_0^2 + x_1^2 - 2x_0x_1] \tag{81}$$

It is easy to see that the functions p_1, p_2 given in (81) satisfy (80) for $k = 1$, because

$$\int_0^{x_1 - x_0} [(x_1 - u) - x_0] du = \frac{1}{2} (x_1^2 - x_0^2) - x_0(x_1 - x_0) = \frac{1}{2} [x_0^2 + x_1^2 - 2x_0x_1] = p_2(x_0, x_1).$$

Moreover, for an arbitrary $k \geq 1$, the function p_k given by (80) and (81) can be written in the following polynomial form.

Theorem 7 For $k \geq 1$ and $0 \leq x_0 \leq x_1 \leq \dots$, it holds

$$p_k(x_0, x_1, \dots, x_{k-1}) = \sum_{(i_0, i_1, \dots, i_{k-1}) \in S_k} (-1)^{q_k(i_0, i_1, \dots, i_{k-1})} \frac{x_0^{i_0} x_1^{i_1}}{i_0! i_1!} \dots \frac{x_{k-1}^{i_{k-1}}}{i_{k-1}!} \tag{82}$$

where

$$S_k = \{(i_0, i_1, \dots, i_{k-1}) \in \{0, 1, \dots\}^k : i_0 + i_1 + \dots + i_{k-1} = k \text{ and if } i_s = l > 1, \\ \text{then } i_{s-1} = i_{s-2} = \dots = i_{s-l+1} = 0\},$$

(the $s - j$ are modulo k) and $q_k(i_0, i_1, \dots, i_{k-1}) = 1 + \sum_{s=0}^{k-1} \mathbf{1}(i_s > 0)$.

Proof By induction with respect to $k \geq 2$, from (80) we easily get that p_k is translation invariant in the sense that

$$p_k(x_0 + u, x_1 + u, \dots, x_{k-1} + u) = p_k(x_0, x_1, \dots, x_{k-1}) \quad (83)$$

for each $u \geq 0$ and $k = 2, 3, \dots$. Using (83), we can rewrite the recursion formula (80) as follows:

$$p_{k+1}(x_0, x_1, \dots, x_k) = \sum_{n=0}^{k-1} \int_{x_n - x_0}^{x_{n+1} - x_0} [p_k(\underbrace{x_0 + u, \dots, x_0 + u}_n, x_{n+1}, \dots, x_k) \\ - p_k(\underbrace{x_0 + u, \dots, x_0 + u}_{n+1}, x_{n+1}, \dots, x_{k-1})] du.$$

Thus, we have

$$p_{k+1}(x_0, x_1, \dots, x_k) = \sum_{n=0}^{k-1} \int_{x_n}^{x_{n+1}} [p_k(\underbrace{v, \dots, v}_n, x_{n+1}, \dots, x_k) \\ - p_k(\underbrace{v, \dots, v}_{n+1}, x_{n+1}, \dots, x_{k-1})] dv. \quad (84)$$

Clearly, for $k = 1, 2$, the formulas (81) and (82) coincide. Assuming now that (82) is true for some natural k , we show that it also holds for $k + 1$. By inserting (82) into the right-hand side of (84) we get

$$p_{k+1}(x_0, x_1, \dots, x_k) = \sum_{n=0}^{k-1} \sum_{(i_0, i_1, \dots, i_{k-1}) \in S_k} (-1)^{q_k(i_0, i_1, \dots, i_{k-1})} \\ \int_{x_n}^{x_{n+1}} \left[\frac{v^{i_0 + \dots + i_{n-1}} x_{n+1}^{i_n}}{i_0! \dots i_{n-1}! i_n!} \dots \frac{x_k^{i_{k-1}} v^{i_0 + \dots + i_n} x_{n+1}^{i_{n+1}}}{i_{k-1}! i_0! \dots i_n! i_{n+1}!} \dots \frac{x_{k-1}^{i_{k-1}}}{i_{k-1}!} \right] dv \\ = \sum_{n=0}^{k-1} \sum_{(i_0, i_1, \dots, i_{k-1}) \in S_k} (-1)^{q_k(i_0, i_1, \dots, i_{k-1})} \left[\frac{x_{n+1}^{i_0 + \dots + i_{n+1}}}{(i_0 + \dots + i_{n-1} + 1) i_0! \dots i_n! i_{n+1}!} \frac{x_{n+2}^{i_{n+1}}}{i_{n+1}!} \dots \frac{x_{k-1}^{i_{k-1}}}{i_{k-1}!} \right. \\ - \frac{x_n^{i_0 + \dots + i_{n-1} + 1}}{(i_0 + \dots + i_{n-1} + 1) i_0! \dots i_{n-1}! i_n!} \frac{x_{n+1}^{i_n}}{i_n!} \dots \frac{x_{k-1}^{i_{k-1}}}{i_{k-1}!} \\ \left. - \frac{x_{n+1}^{i_0 + \dots + i_{n+1} + 1}}{(i_0 + \dots + i_n + 1) i_0! \dots i_{n+1}! i_{n+2}!} \frac{x_{n+2}^{i_{n+2}}}{i_{n+2}!} \dots \frac{x_{k-1}^{i_{k-1}}}{i_{k-1}!} \right. \\ \left. + \frac{x_n^{i_0 + \dots + i_n + 1}}{(i_0 + \dots + i_n + 1) i_0! \dots i_n! i_{n+1}!} \frac{x_{n+1}^{i_{n+1}}}{i_{n+1}!} \dots \frac{x_{k-1}^{i_{k-1}}}{i_{k-1}!} \right].$$

Next we re-order the summands of the last expression. This gives

$$p_{k+1}(x_0, x_1, \dots, x_k) = I_0 + \sum_{n=1}^{k-1} I_n + I_k$$

where

$$I_0 = \sum_{(i_0, i_1, \dots, i_{k-1}) \in S_k} (-1)^{q_k(i_0, i_1, \dots, i_{k-1})} \left[\frac{x_0^{i_0+1} x_1^{i_1}}{(i_0+1)i_0! i_1!} \cdots \frac{x_{k-1}^{i_{k-1}} x_0^1 x_1^{i_0}}{i_{k-1}! 1! i_0!} \cdots \frac{x_k^{i_{k-1}}}{i_{k-1}!} \right],$$

$$I_k = \sum_{(i_0, i_1, \dots, i_{k-1}) \in S_k} (-1)^{q_k(i_0, i_1, \dots, i_{k-1})} \left[\frac{1}{i_0 + \dots + i_{k-2} + 1} - \frac{1}{i_0 + \dots + i_{k-1} + 1} \right]$$

$$\times \frac{x_k^{i_0 + \dots + i_{k-1} + 1}}{i_0! \dots i_{k-1}!}$$

and, for $1 \leq n \leq k-1$,

$$I_n = \sum_{(i_0, i_1, \dots, i_{k-1}) \in S_k} (-1)^{q_k(i_0, i_1, \dots, i_{k-1})}$$

$$\left[\left(\frac{1}{i_0 + \dots + i_{n-2} + 1} - \frac{1}{i_0 + \dots + i_{n-1} + 1} \right) \frac{x_n^{i_0 + \dots + i_{n-1} + 1} x_{n+1}^{i_n} \cdots x_k^{i_{k-1}}}{i_0! \dots i_{n-1}! i_n! \cdots i_{k-1}!} \right.$$

$$\left. - \left(\frac{1}{i_0 + \dots + i_{n-1} + 1} - \frac{1}{i_0 + \dots + i_n + 1} \right) \frac{x_n^{i_0 + \dots + i_n + 1} x_{n+1}^{i_{n+1}} \cdots x_k^{i_{k-1}}}{i_0! \dots i_n! i_{n+1}! \cdots i_{k-1}!} \right].$$

Thus the proof of (82) will be finished if we show that, for each $n = 0, 1, \dots, k$,

$$I_n = \sum_{\{(i_0, i_1, \dots, i_k) \in S_{k+1} : i_0 = \dots = i_{n-1} = 0, i_n \geq n+1\}} (-1)^{q_{k+1}(i_0, i_1, \dots, i_k)} \frac{x_0^{i_0} x_1^{i_1} \cdots x_k^{i_k}}{i_0! i_1! \cdots i_k!}. \quad (85)$$

It can easily be seen that (85) holds for $n = 0$. Namely, in the sum which defines I_0 , each non-negative term in the brackets with $i_0 = 0$ appears once more as a minus term (with $i_{k-1} = 0$). Consequently, these terms cancel each other out. Furthermore,

$$q_k(i_0, i_1, \dots, i_{k-1}) = q_{k+1}(i_0 + 1, i_1, \dots, i_{k-1}, 0)$$

and

$$q_k(i_0, i_1, \dots, i_{k-1}) + 1 = q_{k+1}(1, i_0, i_1, \dots, i_{k-1}).$$

This gives (85) for $n = 0$. In order to prove (85) for $n = 1, 2, \dots, k-1$ we proceed in the following way. Observe that, in the brackets of the definition of I_n for $1 \leq n \leq k-1$, the non-negative terms with $i_{n-1} = 0$ and the minus terms with $i_n = 0$ vanish. Furthermore we have $i_0 + \dots + i_{n-1} \geq n$ if $i_{n-1} > 0$ and, analogously, $i_0 + \dots + i_n \geq n+1$ if $i_n > 0$. Thus it suffices to use the following fact: For each $j \in \{2, 3, \dots\}$ and $n \in \{0, 1, \dots, j-2\}$ the sum

$$I_j^{(n)} = \sum_{(i_0, i_1, \dots, i_n) \in S_{j-1}^{(n)}} (-1)^{q_n(i_0, i_1, \dots, i_n)} \left(\frac{1}{i_0 + \dots + i_{n-1} + 1} - \frac{1}{i_0 + \dots + i_n + 1} \right) \frac{1}{i_0! \dots i_n!},$$

where

$$S_{j-1}^{(n)} = \{(i_0, i_1, \dots, i_n) \in \{0, 1, \dots\}^{n+1} : i_0 + i_1 + \dots + i_n = j-1, i_n > 0 \text{ and if } i_s = l > 1, \text{ then } i_{s-1} = i_{s-2} = \dots = i_{(s-l+1)_+} = 0\},$$

simplifies to

$$I_j^{(n)} = \frac{j - (n + 1)}{j!}. \quad (86)$$

This gives (85) for $n = 1, 2, \dots, k - 1$. Moreover, from (86) putting $j = k + 1$ and $n = k - 1$, we get (85) for $n = k$. Finally we show how (86) follows from standard combinatorial formulas. From the definition of $S_{j-1}^{(n)}$ we get that, in the sum defining $I_j^{(n)}$, the variable i_n either equals $j - 1$ or belongs to $\{1, \dots, n\}$. With the notation $i = i_n$, this gives

$$I_j^{(n)} = \frac{j-1}{j!} - \sum_{i=1}^n \frac{i}{i!(j-i)j} \sum_{(i_0, i_1, \dots, i_{n-i}) \in S_{j-i-1}^{(n-i)}} (-1)^{q_{n-i}(i_0, i_1, \dots, i_{n-i})} \frac{1}{i_0! \dots i_{n-i}!}.$$

With the notation $s = \min\{l : i_l > 0\}$, the inner sum of the last expression can be written in the following form:

$$\begin{aligned} & \sum_{(i_0, i_1, \dots, i_{n-i}) \in S_{j-i-1}^{(n-i)}} (-1)^{q_{n-i}(i_0, i_1, \dots, i_{n-i})} \frac{1}{i_0! \dots i_{n-i}!} \\ &= \sum_{s=0}^{n-i} \frac{1}{(j-1-n+s)!} \sum_{r=1}^{n-i-s} (-1)^r \sum_{\{i_1 + \dots + i_r = n-i-s : i_l > 0\}} \frac{1}{i_1! \dots i_r!} \\ &= \sum_{s=0}^{n-i} \frac{(-1)^{n-i-s}}{(j-1-n+s)!(n-i-s)!}. \end{aligned}$$

Thus we have

$$\begin{aligned} I_j^{(n)} &= \frac{j-1}{j!} - \sum_{i=1}^n \frac{1}{(i-1)!(j-i)j} \sum_{s=0}^{n-i} \frac{(-1)^{n-i-s}}{(j-1-n+s)!(n-i-s)!} \\ &= \frac{j-1}{j!} - \sum_{s=0}^{n-1} (-1)^s \frac{1}{j s!} \sum_{i=1}^{n-s} \frac{1}{(i-1)!(j-i)(j-1-i-s)!}. \end{aligned}$$

Now it remains to show that

$$\sum_{s=0}^{n-1} (-1)^s \frac{1}{j s!} \sum_{i=1}^{n-s} \frac{1}{(i-1)!(j-i)(j-1-i-s)!} = \frac{n}{j!}. \quad (87)$$

It is easy to see that (87) holds for $n = 1, 2$. Assuming that (87) is true for some $n \leq j - 3$, we show that it also holds for $n + 1$. Namely,

$$\begin{aligned} & \sum_{s=0}^n (-1)^s \frac{1}{j s!} \sum_{i=1}^{n+1-s} \frac{1}{(i-1)!(j-i)(j-1-i-s)!} \\ &= \frac{n}{j!} + \sum_{s=0}^n (-1)^s \frac{1}{j s!} \frac{1}{(n-s)!(j+s-n-1)(j-n-2)!} \\ &= \frac{n}{j!} + \frac{1}{j(j-n-2)!} \sum_{s=0}^n (-1)^s \frac{1}{s!(n-s)!(j+s-n-1)} \\ &= \frac{n}{j!} + \frac{1}{j(j-n-2)!} \frac{1}{(j-n-1)(j-n) \dots (j-1)} \\ &= \frac{n}{j!} + \frac{1}{j!} = \frac{n+1}{j!}. \end{aligned}$$

Thus, (87) is proved. This completes the proof of Theorem 7. \square

References

- [1] Asmussen, S. (1987) *Applied Probability and Queues*. J. Wiley & Sons, Chichester.
- [2] Baccelli, F. (1992) Ergodic theory of stochastic Petri networks. *Ann. Probab.* **20**, 375-396.
- [3] Baccelli, F. and Brémaud, P. (1993) Virtual customers in sensitivity and light traffic analysis via Campbell's formula for point processes. *Adv. Appl. Probab.* **25**, 221-224.
- [4] Baccelli, F. and Brémaud, P. (1994) *Elements of Queueing Theory*. Springer-Verlag, Berlin.
- [5] Baccelli, F., Borovkov, A.A. and Mairesse, J. (1995) On large tandem queueing networks, INRIA report.
- [6] Baccelli, F., Cohen, G., Olsder, G.J. and Quadrat, J.P. (1992) *Synchronization and Linearity*. J. Wiley & Sons, Chichester.
- [7] Bavnick, H., Hooghiemstra, G. and de Waard, E. (1993) An application of Gegenbauer polynomials in queueing theory. *J. Comput. Appl. Math.* **49**, 1-10.
- [8] Blanc, J.P.C. (1992) The power-series algorithm applied to the shortest-queue model. *Operations Res.* **40**, 157-167.
- [9] Błaszczyszyn, B. (1995) Factorial moment expansion for stochastic systems. *Stoch. Proc. Appl.* **45** (to appear)
- [10] Błaszczyszyn, B., Frey, A. and Schmidt, V. (1995) Light-traffic approximations for Markov-modulated multi-server queues. *Stochastic Models* **11** (to appear)
- [11] Błaszczyszyn, B. and Rolski, T. (1993) Queues in series in light traffic. *Ann. Appl. Probab.* **3**, 881-896.
- [12] Błaszczyszyn, B. and Rolski, T. (1995) Expansions for Markov-modulated systems and approximations of ruin probability. *J. Appl. Probab.* **32** (to appear)
- [13] Błaszczyszyn, B., Rolski, T. and Schmidt, V. (1995) Light-traffic approximation in queues and related stochastic models. In: Dshalalow, J.H. (ed.) *Frontiers in Queueing: Models, Methods and Problems*. CRC Press, Boca Raton, Florida.
- [14] Boxma, O.J. (1979) On a tandem queueing model with identical service times at both counters. *Adv. Appl. Probab.* **11**, 616-659.
- [15] Boxma, O.J. and Daduna, H. (1990) Sojourn times in queueing networks. In: Takagi, H. (ed.) *Stochastic Analysis of Computer and Communication Systems*. North Holland, Amsterdam, 401-450.
- [16] Cheng, D. and Yao, D. (1993) Tandem queues with general blocking: a unified model and comparison results. *DEDS: Theory and Applications*, vol. 2 (1993) pp. 207-234.
- [17] G. Cohen, D. Dubois, J.P. Quadrat, and M. Viot. A linear system-theoretic view of discrete event processes. In: *Proceedings of the 22-nd Conference on Decision and Control*. IEEE, 1983.
- [18] G. Cohen, D. Dubois, J.P. Quadrat, and M. Viot. A linear system-theoretic view of discrete event processes and its use for performance evaluation in manufacturing. *IEEE Transactions on Automatic Control*, AC-30:210-220, 1985.
- [19] Franken, P., König, D., Arndt, U. and Schmidt, V. (1982) *Queues and Point Processes*. J. Wiley & Sons, Chichester.

-
- [20] Frey, A. and Schmidt, V. (1995) Taylor-series expansion for multivariate characteristics of risk processes. *Insurance: Mathematics and Economics* (to appear)
- [21] Friedman, H.D. (1965) Reduction methods for tandem queueing systems. *Operations Res.* **13**, 121-131.
- [22] Gong, W.B. and Hu, J.Q. (1992) The MacLaurin series for the GI/G/1 queue. *J. Appl. Probab.* **29**, 176-184.
- [23] Hooghiemstra, G., Keane, M. and van de Ree, S. (1988) Power series for stationary distributions of coupled processor models. *SIAM J. Appl. Math.* **48**, 1159-1166.
- [24] Hu, J.Q. (1994) Analyticity of single-server queues in light traffic. *Queueing Systems* (to appear).
- [25] König, D. and Schmidt, V. (1992) *Random Point Processes*. B.G. Teubner-Verlag, Stuttgart (in Germ.).
- [26] Kroese, D. P. and Schmidt, V. (1995). Light-traffic analysis for queues with spatially distributed arrivals. *Math. Oper. Res.* (to appear).
- [27] Le Gall, P. (1994) The overall sojourn time in tandem queues with identical successive service times and renewal input. *Stoch. Proc. Appl.* **52**, 165-178.
- [28] G.J. Olsder, J.A.C. Resing, R.E. de Vries, M.S. Keane, and G. Hooghiemstra. Discrete event systems with stochastic processing times. *IEEE Transactions on Automatic Control*, AC-35:299-302, 1990.
- [29] Reiman, M.I. and Simon, B. (1989) Open queueing systems in light traffic. *Math. Oper. Res.* **14**, 26-59.
- [30] Simon, B. (1993) Calculating light traffic limits for sojourn times in open Markovian queueing systems. *Stochastic Models* **9**, 213-231.
- [31] Thorisson, H. (1985) The queue GI/G/1: Finite moments of the cycle variables and uniform rates of convergence. *Stoch. Proc. Appl.* **19**, 85-99.
- [32] Zazanis, M.A. (1992) Analyticity of Poisson-driven stochastic systems. *Adv. Appl. Probab.* **24**, 532-541.



Unité de recherche INRIA Lorraine, Technopôle de Nancy-Brabois, Campus scientifique,
615 rue du Jardin Botanique, BP 101, 54600 VILLERS LÈS NANCY
Unité de recherche INRIA Rennes, Irisa, Campus universitaire de Beaulieu, 35042 RENNES Cedex
Unité de recherche INRIA Rhône-Alpes, 46 avenue Félix Viallet, 38031 GRENOBLE Cedex 1
Unité de recherche INRIA Rocquencourt, Domaine de Voluceau, Rocquencourt, BP 105, 78153 LE CHESNAY Cedex
Unité de recherche INRIA Sophia-Antipolis, 2004 route des Lucioles, BP 93, 06902 SOPHIA-ANTIPOLIS Cedex

Éditeur
INRIA, Domaine de Voluceau, Rocquencourt, BP 105, 78153 LE CHESNAY Cedex (France)
ISSN 0249-6399