



**HAL**  
open science

## Transient and Stationary Waiting Times in $(\max, +)$ -Linear Systems with Poisson Input

François Baccelli, Sven Hasenfuss, Volker Schmidt

► **To cite this version:**

François Baccelli, Sven Hasenfuss, Volker Schmidt. Transient and Stationary Waiting Times in  $(\max, +)$ -Linear Systems with Poisson Input. RR-3022, INRIA. 1996. inria-00073671

**HAL Id: inria-00073671**

**<https://inria.hal.science/inria-00073671v1>**

Submitted on 24 May 2006

**HAL** is a multi-disciplinary open access archive for the deposit and dissemination of scientific research documents, whether they are published or not. The documents may come from teaching and research institutions in France or abroad, or from public or private research centers.

L'archive ouverte pluridisciplinaire **HAL**, est destinée au dépôt et à la diffusion de documents scientifiques de niveau recherche, publiés ou non, émanant des établissements d'enseignement et de recherche français ou étrangers, des laboratoires publics ou privés.

***Transient and Stationary Waiting Times in  
(max, +)-Linear Systems with Poisson Input***

François Baccelli – Sven Hasenfuss – Volker Schmidt

**N° 3022**

Octobre 1996

THÈME 1



***rapport  
de recherche***





# Transient and Stationary Waiting Times in $(\max, +)$ -Linear Systems with Poisson Input

François Baccelli – Sven Hasenfuss – Volker Schmidt

Thème 1 — Réseaux et systèmes  
Projet Mistral

Rapport de recherche n° 3022 — Octobre 1996 — 42 pages

**Abstract:** We consider a certain class of vectorial evolution equations, which are linear in the  $(\max, +)$  semi-field. They can be used to model several types of discrete event systems, in particular stochastic service systems where we assume that the arrival process of customers (tokens, jobs, etc.) is Poisson.

Under natural Cramer type conditions on certain variables, we show that the expected waiting time which the  $n$ -th customer has to spend in a given subarea of such a system can be expanded analytically in an infinite power series with respect to the arrival intensity  $\lambda$ .

Furthermore, we state an algorithm for computing all coefficients of this series expansion and derive an explicit finite representation formula for the remainder term.

We also give an explicit finite expansion for expected stationary waiting times in  $(\max, +)$ -linear systems with deterministic service.

**Key-words:** Queueing network, stochastic Petri net, Poisson process, stochastic recurrence equation, stationary state variable, vectorial evolution equation, waiting times, analyticity, Taylor series expansion.

*AMS classification:* 60K25, 60G55, 90B22.

(Résumé : *tsvp*)

INRIA-Sophia Antipolis (France), {Francois.Baccelli}@sophia.inria.fr  
University of Ulm (Germany), {Sven.Hasenfuss}@mathematik.uni-ulm.de  
University of Ulm (Germany), {Volker.Schmidt}@mathematik.uni-ulm.de

Unité de recherche INRIA Sophia-Antipolis  
2004 route des Lucioles, BP 93, 06902 SOPHIA-ANTIPOLIS Cedex (France)  
Téléphone : (33) 93 65 77 77 – Télécopie : (33) 93 65 77 65

# Temps d'attente transitoires et stationnaires des systèmes ( $\max, +$ )-linéaires avec des entrées formant un processus de Poisson

**Résumé :** Nous considérons une classe d'équations d'évolution vectorielles qui sont linéaires dans le semi-anneau  $(\max, +)$ , avec des entrées formant un processus ponctuel de Poisson. Cette classe contient plusieurs exemples de systèmes à événements discrets dont la classe des graphes d'événements stochastiques.

Sous des hypothèses de type Cramer sur les variables aléatoires décrivant les temporisations internes, nous montrons que le vecteur des temps d'attente dans un tel système admet un développement analytique en l'intensité  $\lambda$  du processus de Poisson.

Nous donnons aussi un algorithme pour le calcul des coefficients de ce développement, et une représentation explicite de l'erreur commise en remplaçant la série par une somme finie.

À titre d'illustration, nous donnons une représentation explicite du temps d'attente moyen dans le cas particulier où les temporisations internes sont déterministes.

**Mots-clé :** Réseau de files d'attente, réseau de Petri stochastique, processus de Poisson, équation de récurrence stochastique, temps d'attente stationnaire, développement de Taylor, développement analytique.

*Classification AMS:* 60K25, 60G55, 90B22.

## 1 Introduction

Several types of discrete event systems, in particular stochastic service systems, can be described in terms of linear vectorial evolution equations in the  $(\max, +)$  semi-field, see [1]. In this paper we consider the class of such vectorial evolution equations governing open systems, where we assume that the arrival process of customers (tokens, jobs, etc.) is Poisson. For many queueing networks, it is difficult to obtain exact analytical results for characteristics such as expectations of transient or steady-state waiting times.

We show that under natural Cramer type conditions on certain variables, the expected waiting time which the  $n$ -th customer has to spend in a given subarea of such a system can be expanded analytically in an infinite power series with respect to the arrival intensity  $\lambda$ .

Furthermore, we give an algorithm for computing all coefficients of this series expansion and derive an explicit finite representation formula for the remainder term. Finite expansions, which lead to approximation formulas for the expectation and for further characteristics (like higher-order moments, Laplace transform, tail function) of stationary waiting times in  $(\max, +)$ -linear systems have already been derived in [2] and [3]. Note, however, that in [2] and [3], the remainder term has not been analyzed.

The approach presented in this paper allows one to obtain exact analytical results for expected transient waiting times, as well as for expected stationary waiting times for all arrival intensities that admit a stationary regime. In particular, we give an explicit finite expansion for expected stationary waiting times of a randomly chosen customer in a certain class of  $(\max, +)$ -linear systems with deterministic service. This class contains many important queueing systems, such as tandem queues with various types of blocking (e.g. communication- or manufacturing-blocking), as well as basic manufacturing systems, such as Kanban networks or Job-Shop systems.

Similar questions were discussed by various other authors in the past years. Reiman and Simon ([8], [9]) considered Poisson-driven queueing networks and first showed the existence of expansions of performance measures and calculated derivatives with respect to the arrival rate, similar to those in [2] and [3], but mostly for isolated queues. Gong and Hu [4] derived the MacLaurin series for the moments of the system time and the delay in the GI/G/1 queue. Based on the recursive procedure developed in [4], Hu [5] answers the question of analyticity of single-server queues in light traffic. The method of [4] has also been applied to obtain series expansions for inventory systems, see [6].

Using a different approach,  $(\max, +)$ -linear systems with Poisson input and known services have recently been studied by Jean-Marie [7], where all service times are assumed deterministic. Starting from the task graph representation of such systems, in [7] a recursive algorithm is derived for computing distributions and Laplace transforms of response times in the transient as well as in the stationary regime.

The basic tool for our approach is the class of polynomials introduced for the steady-state case in [3]. In this sense, the present paper is a direct continuation of [3] and [2]. The derivation of the basic

theorems leads us to several new properties of this class of polynomials, including new recurrence formulas, which are of independent interest.

The evolution of open  $(\max, +)$ -linear systems is described by the  $\alpha$ -dimensional vectorial  $(\max, +)$ -linear evolution equation

$$V_{n+1} = A_n \otimes C(\tau_n) \otimes V_n \oplus B_{n+1}, \quad (1)$$

with some initial condition  $V_0$ , where  $\alpha \geq 1$ ,  $\tau_n = T_{n+1} - T_n$ ,  $n \geq 0$ . In this equation,  $X \oplus Y$  denotes the coordinate-wise maximum of the two vectors  $X$  and  $Y$ , and  $A \otimes B$  the  $(\max, +)$  multiplication of the two matrices  $A$  and  $B$  (see [1] for more details on this formalism). The involved variables are the following

- $\{T_n\}$  is a non-decreasing sequence of real-valued random variables (the epochs of the *Poisson arrival point process*);
- $\{A_n\}$  is stationary and ergodic sequence of  $\alpha \times \alpha$  matrix with real-valued random entries;
- $\{B_n\}$  is a stationary and ergodic sequence of  $\alpha \times 1$  matrix with real-valued random entries;
- $\{V_n\}$  is a sequence of  $\alpha$ -dimensional state vectors;
- $C(x)$  is the  $\alpha \times \alpha$  matrix with diagonal entries equal to  $-x$  and all non-diagonal entries equal to  $\varepsilon = -\infty$ .

Throughout the paper, it is assumed that the sequences  $\{A_n\}$  and  $\{B_n\}$  are independent of the Poisson process  $\{T_n\}$ .

Several examples of such evolution equations have been discussed in [3], within the framework of queueing theory and stochastic Petri nets. The interpretation of the components  $V_n^i$  of the state variables  $V_n$  in stochastic event graphs is the waiting time of the  $n$ -th token entering the system until this token triggers the firing of transition  $i$ , where  $i = 1, \dots, \alpha$ . The reader should refer to [3] for detailed examples on the matter.

We have

$$V_n = B_n \oplus \bigoplus_{k=0}^{n-1} C(T_n - T_k) \otimes D_{n,k}, \quad (2)$$

for  $n \geq 1$ , where

$$D_{n,k} = A_n \otimes A_{n-1} \dots \otimes A_k \otimes B_k. \quad (3)$$

Equation (2) is sometimes called the *forward construction* of waiting times. However, for our purposes, it is more convenient to consider the following *backward construction* of the waiting times. In

connection with this, we consider the two-sided infinite extensions of  $\{A_n\}$  and  $\{B_n\}$  and the Poisson process on the whole real line. Then, this backward construction is given by

$$W_n = B_0 \oplus \bigoplus_{k=1}^n C(-T_{-k}) \otimes D_k, \quad (4)$$

where we define

$$D_k = A_0 \otimes A_{-1} \dots \otimes A_{-k} \otimes B_{-k}, \quad (5)$$

for  $n \geq 1$ ;  $D_0 = B_0$ . Since under our assumptions  $W_n \stackrel{d}{=} V_n$ , we will use the simpler backward representation (4) of  $W_n$  from now on. In the following we still need a certain monotonicity property of the  $D_k$ . Namely, we assume that  $\{A_n\}$  and  $\{B_n\}$  are such that

$$0 \leq D_0^i \leq D_1^i \leq \dots \quad (6)$$

holds for all  $i = 1, \dots, \alpha$ , where  $D_k^i$  denotes the  $i$ -th component of the vector  $D_k$ . Sufficient conditions for this are given in [3].

## 2 Main Results

### 2.1 Analyticity and Computation of Coefficients

The following lemma follows from §2.84 in [10], and will be instrumental in the proof of the forthcoming theorem:

**Lemma 1** *Let  $f(\lambda, x_1, \dots, x_n)$  be a continuous function of  $\lambda, x_1, \dots, x_n$ , which is analytic in  $\lambda$  in a domain  $\mathcal{D}$ , for all  $x_1 \in C_1, \dots, x_n \in C_n$ , where  $C_1, \dots, C_n$  are infinite contours.*

*If there exists a function  $g(x_1, \dots, x_n)$  such that*

$$|f(\lambda, x_1, \dots, x_n)| \leq g(x_1, \dots, x_n), \quad \forall \lambda \in \mathcal{D},$$

and

$$\int_{C_1} \dots \int_{C_n} g(x_1, \dots, x_n) dx_1 \dots dx_n < \infty,$$

then the function

$$\int_{C_1} \dots \int_{C_n} f(\lambda, x_1, \dots, x_n) dx_1 \dots dx_n$$

is analytic in  $\lambda \in \mathcal{D}$ . In addition, for all  $\lambda \in \mathcal{D}$ , and  $k \geq 0$ ,

$$\frac{\partial^k}{\partial \lambda^k} \int_{C_1} \dots \int_{C_n} f(\lambda, x_1, \dots, x_n) dx_1 \dots dx_n = \int_{C_1} \dots \int_{C_n} \frac{\partial^k}{\partial \lambda^k} f(\lambda, x_1, \dots, x_n) dx_1 \dots dx_n.$$



We first consider the expected transient waiting time  $\mathbb{E}W_n^i$  for each  $i \in \{1, \dots, \alpha\}$  and  $n \geq 0$ , under some Cramer-type condition on  $D_n^i$ . We show that  $\mathbb{E}W_n^i$  is an analytical function of the arrival intensity  $\lambda$ . For another viewpoint on the problem of analyticity of functionals of Poisson processes, see also [11].

**Theorem 1** *Assume that  $D_n^i$  is such that*

$$\mathbb{E} \left[ e^{aD_n^i} \right] < \infty, \quad (7)$$

for some positive  $a$ . Then  $\mathbb{E}W_n^i$  is an analytical function of the arrival intensity  $\lambda$  in  $(0, \infty)$ , and this function can be continued analytically to the complex domain  $\Re(\lambda) > -a$ , and in particular, it is analytic at point  $\lambda = 0$ .

**Proof** Let  $x_1, \dots, x_n$  all be positive. The density of the random vector  $(-T_{-1}, \dots, -T_{-n})$  at  $(x_1, \dots, x_n)$  is equal to

$$\mathbf{1}(x_1 < x_2 < \dots < x_n) e^{-\lambda x_n} \lambda^n dx_1 \dots dx_n,$$

where  $\mathbf{1}(E)$  denotes the indicator function of the set  $E$ . So, (4) yields

$$\mathbb{E} \left[ W_n^i \right] = \int_0^\infty \dots \int_0^\infty \mathbb{E} [\max\{D_0^i, D_1^i - x_1, \dots, D_n^i - x_n\}] \mathbf{1}(x_1 < x_2 < \dots < x_n) e^{-\lambda x_n} \lambda^n dx_1 \dots dx_n$$

and consequently

$$\mathbb{E} \left[ W_n^i - W_{n-1}^i \right] = \int_0^\infty \dots \int_0^\infty \mathbb{E} [\max\{0, D_n^i - x_n - \max\{D_0^i, D_1^i - x_1, \dots, D_{n-1}^i - x_{n-1}\}\}] \mathbf{1}(x_1 < x_2 < \dots < x_n) e^{-\lambda x_n} \lambda^n dx_1 \dots dx_n.$$

The function

$$f(\lambda, x_1, \dots, x_n) = \mathbb{E} [\max\{0, D_n^i - x_n - \max\{D_0^i, D_1^i - x_1, \dots, D_{n-1}^i - x_{n-1}\}\}] \mathbf{1}(x_1 < x_2 < \dots < x_n) e^{-\lambda x_n}$$

is continuous and such that

$$|f(\lambda, x_1, \dots, x_n)| \leq g(x_1, \dots, x_n)$$

with

$$g(x_1, \dots, x_n) = \mathbb{E} [\max\{0, D_n^i - x_n - \max\{D_0^i, D_1^i - x_1, \dots, D_{n-1}^i - x_{n-1}\}\}] \mathbf{1}(x_1 < x_2 < \dots < x_n) e^{ax_n}.$$

Thus

$$\begin{aligned}
& \int_0^\infty \dots \int_0^\infty g(x_1, \dots, x_n) dx_1 \dots dx_n \\
&= \mathbb{E} \left[ \int_0^\infty \dots \int_0^\infty \max\{0, D_n^i - x_n - \max\{D_0^i, D_1^i - x_1, \dots, D_{n-1}^i - x_{n-1}\}\} \right. \\
&\quad \left. \mathbf{1}(x_1 < x_2 < \dots < x_n) e^{ax_n} dx_1 \dots dx_n \right] \\
&= \mathbb{E} \left[ \int_0^{D_n^i} \dots \int_0^{D_n^i} \max\{0, D_n^i - x_n - \max\{D_0^i, D_1^i - x_1, \dots, D_{n-1}^i - x_{n-1}\}\} \right. \\
&\quad \left. \mathbf{1}(x_1 < x_2 < \dots < x_n) e^{ax_n} dx_1 \dots dx_n \right] \\
&\leq \mathbb{E} \left[ \int_0^{D_n^i} \dots \int_0^{D_n^i} D_n^i e^{ax_n} dx_1 \dots dx_n \right] \\
&\leq \mathbb{E} \left[ (D_n^i)^n \frac{e^{aD_n^i} - 1}{a} \right] < \infty,
\end{aligned}$$

where we made use of (7) to prove that the last expression is finite. In view of Lemma 1,  $\mathbb{E}[W_n^i - W_{n-1}^i]$  is analytic for  $\lambda \in \mathcal{D}$ , where  $\mathcal{D}$  is the half plane  $\mathcal{R}(\lambda) > -a$ . Using (6), we get by the same argument that  $\mathbb{E}[W_m^i - W_{m-1}^i]$  is analytic in the same region for all  $0 < m \leq n$ . Since  $\mathbb{E}W_0^i$  is constant in  $\lambda$  and therefore analytic, an immediate finite induction shows that  $\mathbb{E}W_n^i$  is also analytic for  $\lambda \in \mathcal{D}$ .  $\square$

Moreover, we can apply the same construction which was already used in [3] to obtain the following expression for the coefficients of the infinite power-series expansion of  $\mathbb{E}W_{n+1}^i$  with respect to the arrival intensity  $\lambda$ .

**Theorem 2** For each  $\lambda \geq 0$ ,

$$\mathbb{E}[W_{n+1}^i] = \sum_{k=0}^n \lambda^k \mathbb{E}[p_{k+1}(D_0^i, \dots, D_k^i)] + \sum_{k=n+1}^{\infty} \lambda^k \mathbb{E}[p_{k+1}(D_0^i, \dots, D_{n-1}^i, \underbrace{D_n^i, \dots, D_n^i}_{k+1-n})], \quad (8)$$

where

$$p_k(x_0, x_1, \dots, x_{k-1}) = \sum_{(i_0, i_1, \dots, i_{k-1}) \in S_k} (-1)^{q_k(i_0, i_1, \dots, i_{k-1})} \frac{x_0^{i_0}}{i_0!} \frac{x_1^{i_1}}{i_1!} \dots \frac{x_{k-1}^{i_{k-1}}}{i_{k-1}!}, \quad (9)$$

with

$$S_k = \left\{ (i_0, i_1, \dots, i_{k-1}) \in \{0, 1, \dots\}^k : i_0 + i_1 + \dots + i_{k-1} = k \text{ and if } i_s = l > 1, \right. \\
\left. \text{then } i_{s-1} = i_{s-2} = \dots = i_{s-l+1} = 0 \right\}, \quad (10)$$

(the  $s - j$  are modulo  $k$ ) and

$$q_k(i_0, i_1, \dots, i_{k-1}) = 1 + \sum_{s=0}^{k-1} \mathbf{1}(i_s > 0). \quad (11)$$

**Proof** Note that the (transient) waiting time  $W_{n+1}$  defined above can be brought to the form of the stationary waiting time  $W$  defined in equation (9) of [3] if we set  $D_k = D_n$ , for  $k \geq n$ , since  $T_{-k}$  is non-increasing in  $k$ . Thus, proceeding in the same way as in §7 of [3] we obtain that the functional  $W_{n+1}$  is admissible in the Reiman–Simon sense (see [9]), under the Cramer condition (7). Using the results of §6 in [3], we therefore have the following result: For each  $m \geq 0$ ,

$$\begin{aligned} \mathbb{E}[W_{n+1}^i] &= \sum_{k=0}^{\min\{m,n\}} \lambda^k \mathbb{E}[p_{k+1}(D_0^i, \dots, D_k^i)] \\ &+ \sum_{k=\min\{m,n\}+1}^m \lambda^k \mathbb{E}\left[p_{k+1}(D_0^i, \dots, D_{n-1}^i, \underbrace{D_n^i, \dots, D_n^i}_{k+1-n})\right] + O(\lambda^{m+1}). \end{aligned}$$

Now, in view of Theorem 1, we obtain (8) by letting  $m$  go to  $\infty$ .  $\square$

**Remark** Formula (8) can also be obtained by the representation of  $\mathbb{E}W_1^i - W_0^i$  in Theorem 1. Let us exemplify this on the expansion of  $\mathbb{E}W_1^i - W_0^i$ . Using the last assertion of Lemma 1, we obtain

$$\begin{aligned} \left. \frac{d^k}{d\lambda^k} \right|_{\lambda=0} \mathbb{E}[W_1^i - W_0^i] &= \int_0^\infty \mathbb{E}[\max\{D_0^i, D_1^i - x_1\} - D_0^i] \left. \frac{\partial^k}{\partial \lambda^k} \right|_{\lambda=0} e^{-\lambda x_1} \lambda dx_1 \\ &= \int_0^\infty \mathbb{E}[\max\{D_0^i, D_1^i - x_1\} - D_0^i] k(-x_1)^{k-1} dx_1. \end{aligned}$$

Finally, using the results of §6 in [3], it is easy to check that indeed

$$\mathbb{E}\left[p_{k+1}(D_0^i, \underbrace{D_1^i, \dots, D_1^i}_k)\right] = \int_0^\infty \mathbb{E}[\max\{D_0^i, D_1^i - x_1\} - D_0^i] \frac{(-x_1)^{k-1}}{(k-1)!} dx_1.$$

For the rest of the paper we will omit the superscript  $i$  in order not to overload notation but always mean an arbitrarily chosen but fixed component of the vector  $(W_n^i)_{i=1, \dots, \alpha}$  or  $(D_n^i)_{i=1, \dots, \alpha}$ , respectively.

## 2.2 Explicit Representation of the Remainder Term

We want to investigate the series expansion (8) of  $\mathbb{E}[W_{n+1}]$  more closely.

Note that, for  $\{D_n\}$  deterministic, (8) implies

$$\begin{aligned} \mathbb{E}[W_{n+1}] &= \sum_{k=0}^n \lambda^k \mathbb{E}[p_{k+1}(D_0, \dots, D_k)] \\ &\quad + \frac{1}{\lambda} \sum_{k=n+1}^{\infty} \mathbb{E}\left[p_{k+1}(\lambda(D_0 - D_n), \dots, \lambda(D_{n-1} - D_n), \underbrace{0, \dots, 0}_{k+1-n})\right], \end{aligned} \quad (12)$$

where we used the translation-invariance property of the polynomials  $p_k$ . Namely,

$$p_{k+1}(x_0, x_1, \dots, x_k) = p_{k+1}(x_0 + t, x_1 + t, \dots, x_k + t) \quad (13)$$

holds for all  $k \geq 1$  and  $t \in \mathbb{R}$ . A proof of (13) is given in Section 4. Consider the remainder term  $\frac{1}{\lambda} R_{n+1}$  involved in the righthand side of (12), where we define

$$R_{n+1} = \sum_{k=n+1}^{\infty} p_{k+1}(\lambda(D_0 - D_n), \dots, \lambda(D_{n-1} - D_n), \underbrace{0, \dots, 0}_{k+1-n}). \quad (14)$$

Then we can state a series expansion of  $\mathbb{E}W_{n+1}$  with the explicit representation of its remainder term defined in (14).

**Theorem 3** *For each arrival intensity  $\lambda > 0$  and for all  $n \geq 0$ ,*

$$\mathbb{E}[W_{n+1}] = \sum_{k=0}^n \lambda^k \mathbb{E}[p_{k+1}(D_0, \dots, D_k)] + \frac{1}{\lambda} \mathbb{E}[R_{n+1}], \quad (15)$$

where

$$\begin{aligned} R_{n+1} &= \sum_{m=0}^{n-1} \mathcal{T}_{n+1}(e^{\lambda(D_m - D_n)}) - \sum_{m=0}^{n-2} \sum_{j=1}^{n-1-m} \lambda^j \mathcal{T}_{n+1-j}(e^{\lambda(D_m - D_n)}) \\ &\quad \left\{ p_j(D_{m+1} - D_n, \dots, D_{m+j} - D_n) - p_j(0, D_{m+1} - D_n, \dots, D_{m+j-1} - D_n) \right\} \end{aligned} \quad (16)$$

$$\text{and } \mathcal{T}_j(e^x) = \sum_{k=j+1}^{\infty} \frac{x^k}{k!} = e^x - \sum_{k=0}^j \frac{x^k}{k!}.$$

We can also rewrite the remainder  $R_{n+1}$  and collect all coefficients of those expressions involving the same powers of  $\lambda$  to obtain another interesting representation of the expectation of the transient waiting time  $W_{n+1}$ .

**Theorem 4** *For each arrival intensity  $\lambda > 0$  and for all  $n \geq 0$ ,*

$$\begin{aligned} \mathbb{E}[W_{n+1}] &= \frac{1}{\lambda} \sum_{m=0}^{n-1} \mathbb{E}\left[e^{-\lambda(D_n - D_m)} - 1\right] + \mathbb{E}[D_n] + \sum_{j=0}^{n-2} \lambda^j \sum_{m=0}^{n-j-2} \mathbb{E}\left[e^{-\lambda(D_n - D_m)} \right. \\ &\quad \left. \left\{ p_{j+1}(D_n, D_{m+1}, \dots, D_{m+j}) - p_{j+1}(D_{m+1}, \dots, D_{m+1+j}) \right\}\right] \end{aligned} \quad (17)$$

Before stating the combinatorial properties of the polynomials which will allow one to prove Theorems 3 and 4 in Section 5, we first want to give explicit formulæ for the expectation of some of the transient waiting times considered in this paper.

**Examples** We want to look at the expectation of the waiting times of the first four customers:

$$\begin{aligned}
\mathbb{E}[W_1] &= \mathbb{E}[D_0], \\
\mathbb{E}[W_2] &= \frac{1}{\lambda} \mathbb{E}[e^{-\lambda(D_1-D_0)} - 1] + \mathbb{E}[D_1], \\
\mathbb{E}[W_3] &= \frac{1}{\lambda} \left\{ \mathbb{E}[e^{-\lambda(D_2-D_0)} - 1] + \mathbb{E}[e^{-\lambda(D_2-D_1)} - 1] \right\} + \mathbb{E}[D_2] \\
&\quad + \mathbb{E}[(D_2 - D_1) e^{-\lambda(D_2-D_0)}], \\
\mathbb{E}[W_4] &= \frac{1}{\lambda} \left\{ \mathbb{E}[e^{-\lambda(D_3-D_0)} - 1] + \mathbb{E}[e^{-\lambda(D_3-D_1)} - 1] + \mathbb{E}[e^{-\lambda(D_3-D_2)} - 1] \right\} \\
&\quad + \mathbb{E}[D_3] + \mathbb{E}[(D_3 - D_1) e^{-\lambda(D_3-D_0)}] + \mathbb{E}[(D_3 - D_2) e^{-\lambda(D_3-D_1)}] \\
&\quad + \lambda \frac{1}{2} \mathbb{E}[(D_3^2 - D_2^2 + 2D_1(D_2 - D_3)) e^{-\lambda(D_3-D_0)}].
\end{aligned}$$

### 2.3 Expansion of Stationary Characteristics

Let  $a$  denote the maximal Lyapunov exponent of the evolution equation (1), i.e.

$$a = \lim_{r \rightarrow \infty} \frac{1}{r} \max_{i,j} \left\{ \left( \bigotimes_{k=0}^r A_{-k} \right)_{i,j} \right\}. \quad (18)$$

It was shown in Chapter 7 of [1] that, for all  $\lambda < a^{-1}$ , the waiting times  $W_n$  have an almost surely finite limit  $W$  as  $n \rightarrow \infty$  which is given by

$$W = B_0 \oplus \bigoplus_{k=1}^{\infty} C(-T_{-k}) \otimes D_k. \quad (19)$$

Now we additionally assume that the net-topology is such that the sequence of the  $D_k$ 's is given by

$$D_k = \begin{cases} \eta_k, & \text{for } k = 0, \dots, \xi - 1, \\ \eta_\xi + (k - \xi)a, & \text{for } k \geq \xi, \end{cases}. \quad (20)$$

where  $0 \leq \eta_0^i \leq \eta_1^i \leq \dots \leq \eta_\xi^i$  and  $\xi \in \mathbb{N}_0$ . This case covers many important queueing system with deterministic service, such as tandem queues with various types of blocking (e.g. communication-

or manufacturing-blocking), as well as basic manufacturing systems, such as Kanban networks or Job-Shop systems. However, we want to mention that this assumption does not comprise all scenarios of possible stationary behavior in (max,+)-linear system with deterministic service. More precisely, this covers the case with deterministic matrices  $A_k = A$ ,  $B_k = B$ , for all  $k$ , such that the cyclicity of  $A$  is equal to 1 (see [1]).

Using the explicit representation formula given in Theorem 4 for the remainder term in the expansion of  $\mathbb{E}[W_n]$ , we obtain the following finite expansion of the expected stationary waiting times  $\mathbb{E}[W^{\{\xi+1\}}]$ , where the superscript indicates the special structure of the underlying sequence  $\{D_k\}$  as defined in (20).

**Theorem 5** *Let the sequence  $D_0, D_1, \dots$  be defined according to (20) for some  $\xi \in \mathbb{N}_0$  and  $\eta_0, \dots, \eta_\xi \in \mathbb{R}$ . Then the expectation of the stationary waiting time  $W^{\{\xi+1\}}$  has the following explicit representation for all arrival intensities  $\lambda \in [0, \frac{1}{a}]$ :*

$$\begin{aligned} \mathbb{E}[W^{\{\xi+1\}}] &= \frac{a\rho}{2(1-\rho)} + \eta_\xi - \frac{\xi}{\lambda} + \frac{(1-\rho)}{\lambda} \left\{ \sum_{m=0}^{\xi-1} e^{-\lambda(\eta_\xi + (m-\xi)a - \eta_m)} + \sum_{m=0}^{\xi-2} e^{-\lambda(\eta_\xi + (m-\xi)a - \eta_m)} \right. \\ &\quad \left. \sum_{l=1}^{\xi-1-m} e^{-\rho l} \left\{ p_l(\lambda(\eta_\xi + (l+m-\xi)a), \lambda\eta_{m+1}, \dots, \lambda\eta_{m+l-1}) - p_l(\lambda\eta_{m+1}, \dots, \lambda\eta_{m+l}) \right\} \right\}. \end{aligned}$$

Before we start proving this theorem, we want to look at the explicit formula for  $\mathbb{E}[W^{\{\xi+1\}}]$  for some particular values of  $\xi$ . For small values of  $\xi$  the expectation of the stationary waiting time is given by the following formulas:

$$\begin{aligned} \mathbb{E}[W^{\{1\}}] &= \frac{a\rho}{2(1-\rho)} + \eta_0 \\ \mathbb{E}[W^{\{2\}}] &= \frac{a\rho}{2(1-\rho)} + \eta_1 - \frac{1}{\lambda} \left\{ 1 - (1-\rho)e^{-\lambda(\eta_1 - a - \eta_0)} \right\} \\ \mathbb{E}[W^{\{3\}}] &= \frac{a\rho}{2(1-\rho)} + \eta_2 - \frac{2}{\lambda} + \frac{(1-\rho)}{\lambda} \left\{ e^{-\lambda(\eta_2 - 2a - \eta_0)} + e^{-\lambda(\eta_2 - a - \eta_1)} \right. \\ &\quad \left. + \lambda(\eta_2 - a - \eta_1)e^{-\lambda(\eta_2 - a - \eta_0)} \right\} \\ \mathbb{E}[W^{\{4\}}] &= \frac{a\rho}{2(1-\rho)} + \eta_3 - \frac{3}{\lambda} + \frac{(1-\rho)}{\lambda} \left\{ e^{-\lambda(\eta_3 - 3a - \eta_0)} + e^{-\lambda(\eta_3 - 2a - \eta_1)} + e^{-\lambda(\eta_3 - a - \eta_2)} \right. \\ &\quad \left. + \lambda(\eta_3 - 2a - \eta_1)e^{-\lambda(\eta_3 - 2a - \eta_0)} + \lambda(\eta_3 - a - \eta_2)e^{-\lambda(\eta_3 - a - \eta_1)} \right\} \end{aligned}$$

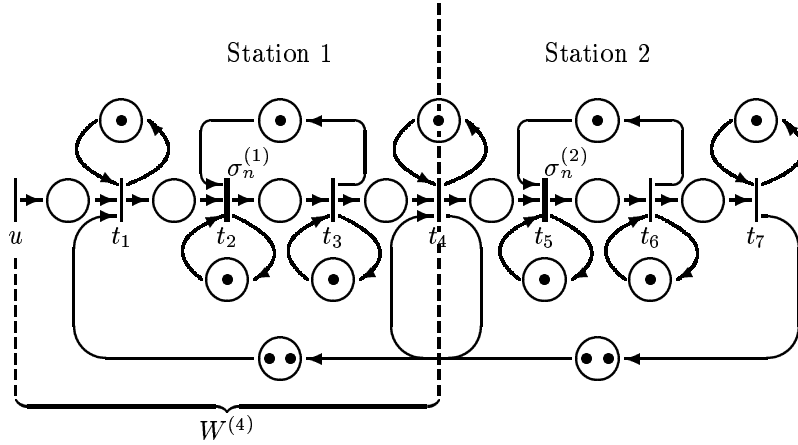

Figure 1: Petri-net representation of a two-stage Kanban system

$$+ \left\{ p_2(\lambda(\eta_3 - a), \lambda\eta_1) - p_2(\lambda\eta_1, \lambda\eta_2) \right\} e^{-\lambda(\eta_3 - a - \eta_0)}.$$

Examples of  $(\max, +)$ -linear systems with  $\xi$  small are given by tandem queues and the Kanban system considered in Section 4.2 of [3]. Before we continue we want to give a further discussion of these examples that show the applicability of the theorems stated in Section 2.

### 3 Examples

#### 3.1 A Two-Stage Kanban System

In this section we apply the obtained results to analyze a two-stage Kanban system. A Petri-net representation of this system is given in Figure 1. This example has already been studied in Section 4.2.4 of [3], where polynomial approximations for mean stationary waiting times were calculated. Note, however, that the remainder term has not been considered in [3].

**Alternative 1** We want to apply Theorem 5 to the stationary mean waiting time  $\mathbb{E}[W^4]$  starting from the arrival of a customer to the system (or, equivalently, the firing of transition  $u$ ), until this customer leaves Station 1 (firing of transition  $t_4$ ). To give a numerical example we assume that the service time  $\sigma_n^{(1)}$  of the machine at Station 1 is constant and equal to 3 units of time. Also, the service time  $\sigma_n^{(2)}$  of machine 2 at the second station is assumed to be constant and equal to 5 units of time.

Thus, we can use the formulas obtained in Section 4.2.4 of [3] to learn that  $D_0^4 = 3$ ,  $D_1^4 = 6$ ,  $D_2^4 = 9$  and  $D_n^4 = 13 + 5(n - 3)$ , for  $n \geq 3$ , and get, for  $\lambda \in [0, 0.2)$ ,

$$\begin{aligned} \mathbb{E}[W^4] &= \frac{25\lambda}{2 - 10\lambda} + 13 - \frac{3}{\lambda} \\ &\quad + \frac{(1 - 5\lambda)(e^{5\lambda} + e^{3\lambda} + e^\lambda - 3\lambda - \lambda e^{-2\lambda} - \frac{5}{2}\lambda^2 e^{-5\lambda})}{\lambda}. \end{aligned} \quad (21)$$

On the other hand, if we want to investigate  $W^7$ , i.e. the delay between the arrival of a customer into the system and his departure from the system, or, equivalently, from Station 2, we find  $D_n^7 = 8 + 5n$ , for all  $n \geq 0$ . Thus, in a sense, this system characteristic is much simpler, and we obtain

$$\mathbb{E}[W^7] = \frac{25\lambda}{2 - 10\lambda} + 8 = \frac{16 - 55\lambda}{2 - 10\lambda}, \quad (22)$$

for  $\lambda \in [0, 0.2)$ .

**Alternative 2** As a next example we consider the same system as above, only that this time the service times are given by  $\sigma_n^{(1)} = \sigma_n^{(2)} = 4$ . So we still have the same total service time per customer, with the only difference that the work is now balanced symmetrically on both servers. This gives  $D_n^4 = 4 + 4n$  and  $D_n^7 = 8 + 4n$ , for  $n \geq 0$ , respectively. Thus, Theorem 5 yields

$$\mathbb{E}[W^4] = \frac{4 - 8\lambda}{1 - 4\lambda} \quad \text{and} \quad \mathbb{E}[W^7] = \frac{8 - 24\lambda}{1 - 4\lambda}, \quad (23)$$

for  $0 \leq \lambda < 0.25$ . Next, we want to use the mean stationary waiting times computed in (21), (22) and (23) to compare the performance of these two system configurations. Direct computation or looking at Figure 2 yields

$$\mathbb{E}^{(3-5)}[W^7] = \frac{16 - 55\lambda}{2 - 10\lambda} > \frac{8 - 24\lambda}{1 - 4\lambda} = \mathbb{E}^{(4-4)}[W^7],$$

for all  $0 < \lambda < 0.2$ . The additional superscripts were introduced to help keeping waiting times from different examples apart. If we look at the mean stationary waiting time until leaving Station 1, and plot the different examples in Figure 3, the situation is as follows:

$$\mathbb{E}^{(3-5)}[W^4] \begin{cases} \leq \\ > \end{cases} \mathbb{E}^{(4-4)}[W^4] \quad \text{for} \quad \begin{cases} 0 \leq \lambda \leq 0.1438 \\ 0.1438 < \lambda < 0.2. \end{cases}$$

**Alternative 3** Interchanging the service times in the first system alternative yields  $D_n^4 = 5 + 5n$  and  $D_n^7 = 8 + 5n$ , for  $n \geq 0$ , and thus

$$\mathbb{E}^{(5-3)}[W^4] = \frac{10 - 25\lambda}{2 - 10\lambda} > \frac{8 - 24\lambda}{1 - 4\lambda} = \mathbb{E}^{(4-4)}[W^4],$$

for all  $0 < \lambda < 0.2$ . Since we have  $\mathbb{E}^{(5-3)}[W^7] = \mathbb{E}^{(3-5)}[W^7]$ , it is immediate that  $\mathbb{E}^{(5-3)}[W^7] > \mathbb{E}^{(4-4)}[W^7]$  holds for all  $0 < \lambda < 0.2$ .



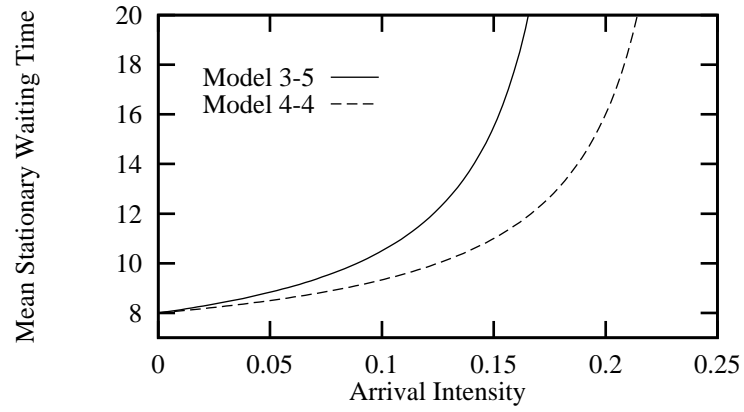

Figure 2: Mean stationary waiting times until leaving Station 2

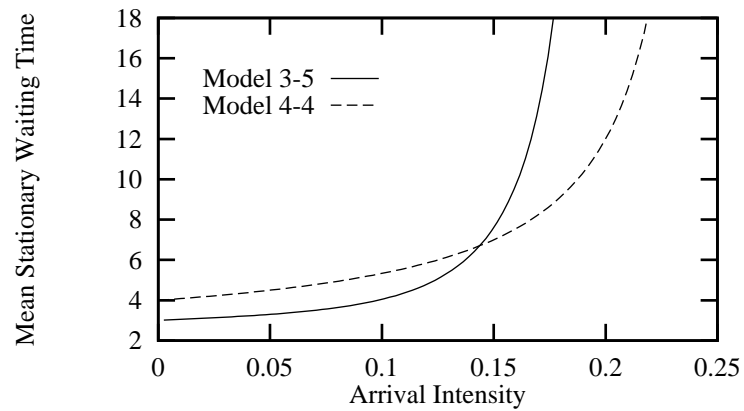

Figure 3: Mean stationary waiting times until leaving Station 1

**Conclusion** We conclude that, compared to a balanced design, shifting service time from Station 1 to Station 2 leads to an increased overall waiting time in the system and yields a better performance at Station 1 only if the arrival intensity is kept under a certain bound. On the other hand, shifting service time from Station 2 to Station 1 even worsens the situation without providing any compensatory benefit whatsoever. Thus, if we take mean stationary waiting times as the critical performance measure for this Kanban system and if short expected delays at Station 1 are not a restriction imposed by the system, a balanced design, where service times are chosen equal, or as close as possible, should be preferred.

### 3.2 A Three-Station Tandem Queueing Network

Since in the previous example the service times were chosen to be deterministic, we want to give another example where the service times are random. We investigate some transient characteristics of a three-single-server FIFO tandem queue with infinite capacity and all queues initially empty. A Petri-net representation of this system is given in Section 4.2.2 of [3]. For this example we assume that an arriving customer experiences identical service times at all servers, i.e.  $\sigma_n^i = \sigma(n)$  for all  $i = 1, 2, 3$ . We investigate the mean delay between an arrival and the time that this customer starts his service at Station 3. The first random variables  $D_n^3$  necessary to answer this question can also be found in [3]:

$$\begin{aligned} D_0^3 &= 2\sigma(0) \\ D_1^3 &= \sigma(1) + 2\max\{\sigma(0), \sigma(1)\} \\ D_2^3 &= \sigma(1) + \sigma(1) + 2\max\{\sigma(0), \sigma(1), \sigma(2)\}. \end{aligned}$$

If we are interested in the mean delay of the second arriving customer, Theorems 3 and 4 imply that we have to calculate

$$\mathbb{E}[W_2] = \frac{1}{\lambda} \mathbb{E} \left[ e^{-\lambda(D_1^3 - D_0^3)} - 1 \right] + \mathbb{E}[D_1^3],$$

or, when using the structure of the  $D_n^3$ 's given above,

$$\begin{aligned} \mathbb{E}[W_2] &= \int_0^\infty \int_0^{x_0} \left\{ \frac{1}{\lambda} e^{-\lambda x_1} + (x_1 + 2x_0) \right\} dF_{\sigma(1)}(x_1) dF_{\sigma(0)}(x_0) \\ &\quad + \int_0^\infty \int_{x_0}^\infty \left\{ \frac{1}{\lambda} e^{-\lambda(3x_1 - 2x_0)} + 3x_1 \right\} dF_{\sigma(1)}(x_1) dF_{\sigma(0)}(x_0) - \frac{1}{\lambda}. \end{aligned}$$

Now let us assume that  $\sigma(n)$  is given by a sequence of i.i.d. random variables and that the distribution function  $F_{\sigma(n)}$  is given by  $F_{\sigma(n)}(x) = 1 - e^{-\frac{1}{\beta}x}$ , for all  $x \in [0, \infty)$  and  $n \geq 0$ , where  $\beta > 0$ . Then we

can calculate  $\mathbb{E}[W_2]$  as a function of  $\lambda \geq 0$  and obtain

$$\mathbb{E}[W_2] = \frac{12\beta^3\lambda^2 + 25\beta^2\lambda + 4\beta}{3\beta^2\lambda^2 + 7\beta\lambda + 2}. \quad (24)$$

The same calculation can be done for the mean delay of the third arriving customer. According to Theorem 4 we know that

$$\begin{aligned} \mathbb{E}[W_3] &= \frac{1}{\lambda} \left\{ \mathbb{E}\left[e^{-\lambda(D_2^3 - D_0^3)} - 1\right] + \mathbb{E}\left[e^{-\lambda(D_2^3 - D_1^3)} - 1\right] \right\} \\ &\quad + \mathbb{E}[D_2^3] + \mathbb{E}\left[(D_2^3 - D_1^3)e^{-\lambda(D_2^3 - D_0^3)}\right], \end{aligned}$$

and therefore, in the given context,

$$\begin{aligned} \mathbb{E}[W_3] &+ \frac{2}{\lambda} \\ &= \int_0^\infty \int_0^{x_0} \int_0^{x_0} \left\{ \frac{1}{\lambda} e^{-\lambda(x_1+x_2)} + \frac{1}{\lambda} e^{-\lambda x_2} + (2x_0 + x_1 + x_2) + x_2 e^{-\lambda(x_1+x_2)} \right\} \\ &\quad dF_{\sigma(2)}(x_2) dF_{\sigma(1)}(x_1) dF_{\sigma(0)}(x_0) \\ &+ \int_0^\infty \int_{x_0}^\infty \int_0^{x_1} \left\{ \frac{1}{\lambda} e^{-\lambda(3x_1+x_2-2x_0)} + \frac{1}{\lambda} e^{-\lambda x_2} + (3x_1 + x_2) + x_2 e^{-\lambda(3x_1+x_2-2x_0)} \right\} \\ &\quad dF_{\sigma(2)}(x_2) dF_{\sigma(1)}(x_1) dF_{\sigma(0)}(x_0) \\ &+ \int_0^\infty \int_0^{x_0} \int_{x_0}^\infty \left\{ \frac{1}{\lambda} e^{-\lambda(x_1+3x_2-2x_0)} + \frac{1}{\lambda} e^{-\lambda(3x_2-2x_0)} + (x_1 + 3x_2) \right. \\ &\quad \left. + (3x_2 - 2x_0) e^{-\lambda(x_1+3x_2-2x_0)} \right\} dF_{\sigma(2)}(x_2) dF_{\sigma(1)}(x_1) dF_{\sigma(0)}(x_0) \\ &+ \int_0^\infty \int_{x_0}^\infty \int_{x_1}^\infty \left\{ \frac{1}{\lambda} e^{-\lambda(x_1+3x_2-2x_0)} + \frac{1}{\lambda} e^{-\lambda(3x_2-2x_1)} + (x_1 + 3x_2) \right. \\ &\quad \left. + (3x_2 - 2x_1) e^{-\lambda(x_1+3x_2-2x_0)} \right\} dF_{\sigma(2)}(x_2) dF_{\sigma(1)}(x_1) dF_{\sigma(0)}(x_0). \end{aligned}$$

If we make the same assumption on the service time distribution as we did before, we can evaluate the integrals above. We can use a computer algebra system like MAPLE V or Mathematica to do the symbolic integration and obtain

$$\begin{aligned} \mathbb{E}[W_3] &= \left( 4896\beta^{10}\lambda^9 + 55392\beta^9\lambda^8 + 259504\beta^8\lambda^7 + 655376\beta^7\lambda^6 + 972012\beta^6\lambda^5 \right. \\ &\quad \left. + 864155\beta^5\lambda^4 + 451939\beta^4\lambda^3 + 132462\beta^3\lambda^2 + 19980\beta^2\lambda + 1296\beta \right) / \\ &\quad \left( \left( 144\beta^4\lambda^4 + 552\beta^3\lambda^3 + 708\beta^2\lambda^2 + 342\beta\lambda + 54 \right) \left( 1 + 5\beta\lambda + 6\beta^2\lambda^2 \right) \right) \end{aligned}$$

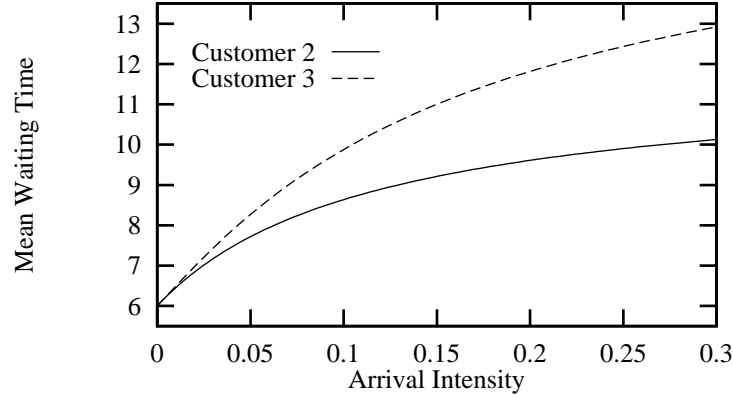

Figure 4: Mean waiting times of the second and third customer.

$$\left(4 + 4\beta\lambda + \beta^2\lambda^2\right)\left(\beta\lambda + 3\right).$$

Both  $\mathbb{E}[W_2]$  and  $\mathbb{E}[W_3]$  are plotted in Figure 4 for  $\beta = 3$ .

## 4 Combinatorial Properties of the Polynomials

The polynomials  $p_k$  appearing in the coefficients of the power series expansions stated in Section 2 are of independent combinatorial interest.

In addition to (13), they have a number of further remarkable properties, which will be instrumental to prove the theorems stated in Section 2 (see Section 5 and 6), and which are collected in the present section. Most of these properties are new, although we also give purely combinatorial proofs of some properties that were already mentioned in [3].

### 4.1 Recursion Formula

In addition to the explicit representation of the polynomials  $p_k$  stated in Theorem 2, another simple recursive construction of these polynomials can be given:

**Theorem 6** *For all  $k \geq 1$  and  $x_0, \dots, x_{k-1} \in \mathbb{R}$ , the polynomials  $p_k(x_0, x_1, \dots, x_{k-1})$  defined in (9) can be expressed recursively by  $p_1(x_0) = x_0$  and*

$$p_{k+1}(x_0, x_1, \dots, x_k)$$

$$= \frac{1}{k+1} \sum_{m=0}^k \{x_m - x_{(m-1 \bmod k+1)}\} p_k(x_{(m \bmod k+1)}, \dots, x_{(m+k-1 \bmod k+1)}). \quad (25)$$

**Proof** We first introduce another notation. Let  $I$  be an additional condition on the indices  $i_j$  considered in the set  $S_k$  in the definition of the polynomials  $p_k$ . Then we denote with  $S_{k+1}^I$  that subset of  $S_{k+1}$  whose elements also satisfy condition  $I$ , i.e.  $S_{k+1}^I = \{(i_0, i_1, \dots, i_k) \in S_{k+1} \cap I\}$ . Next we rewrite statement (25) to

$$p_{k+1}(x_0, x_1, \dots, x_k) = \frac{1}{k+1} \sum_{m=0}^k x_m \left\{ p_k(x_{(m \bmod k+1)}, \dots, x_{(m+k-1 \bmod k+1)}) - p_k(x_{(m+1 \bmod k+1)}, \dots, x_{(m+k \bmod k+1)}) \right\}, \quad (26)$$

a representation, which we will use from now on. Looking at the righthand side of equation (26) we first examine the case that  $m = 0$ , i.e. expression  $x_0 \{p_k(x_0, x_1, \dots, x_{k-1}) - p_k(x_1, x_2, \dots, x_k)\}$ . Using (9) together with the notation introduced in (10), (11) and above, we get

$$\begin{aligned} x_0 p_k(x_0, x_1, \dots, x_{k-1}) &= x_0 \sum_{(i_0, i_1, \dots, i_{k-1}) \in S_k} (-1)^{q_k(i_0, i_1, \dots, i_{k-1})} \prod_{j=0}^{k-1} \frac{x_j^{i_j}}{i_j!} \\ &= \sum_{(i_0, i_1, \dots, i_{k-1}) \in S_k} (-1)^{q_k(i_0, i_1, \dots, i_{k-1})} \frac{x_0^{i_0+1}}{i_0!} \prod_{j=1}^{k-1} \frac{x_j^{i_j}}{i_j!} \\ &= \sum_{(i_0, i_1, \dots, i_{k-1}) \in S_k^{i_0=0}} \dots + \sum_{(i_0, i_1, \dots, i_{k-1}) \in S_k^{i_0>0}} \dots \\ &= \left[ \begin{array}{l} - \sum_{(\tau_0, \tau_1, \dots, \tau_k)} (-1)^{q_{k+1}(\tau_0, \tau_1, \dots, \tau_k)} \prod_{j=0}^k \frac{x_j^{\tau_j}}{\tau_j!} \\ \text{where } \tau_0=1, \tau_k=0 \\ \tau_j=i_j, j=1, \dots, k-1 \\ \text{and } (i_0, i_1, \dots, i_{k-1}) \in S_k^{i_0=0} \end{array} \right] + \left[ \begin{array}{l} \sum_{(\tau_0, \tau_1, \dots, \tau_k)} (-1)^{q_{k+1}(\tau_0, \tau_1, \dots, \tau_k)} \tau_0 \prod_{j=0}^k \frac{x_j^{\tau_j}}{\tau_j!} \\ \text{where } \tau_0=i_0+1>1, \tau_k=0 \\ \tau_j=i_j, j=1, \dots, k-1 \\ \text{and } (i_0, i_1, \dots, i_{k-1}) \in S_k^{i_0>0} \end{array} \right] \end{aligned}$$

on the other hand we see that

$$-x_0 p_k(x_1, x_2, \dots, x_k) = -x_0 \sum_{(i_1, i_2, \dots, i_k) \in S_k} (-1)^{q_k(i_1, i_2, \dots, i_k)} \prod_{j=1}^k \frac{x_j^{i_j}}{i_j!}$$

$$\begin{aligned}
 &= \sum_{(i_1, i_2, \dots, i_k) \in S_k} (-1)^{q_k(i_1, i_2, \dots, i_k) + 1} x_0 \prod_{j=1}^k \frac{x_j^{i_j}}{i_j!} \\
 &= \sum_{(i_1, i_2, \dots, i_k) \in S_k^{i_k=0}} \dots + \sum_{(i_1, i_2, \dots, i_k) \in S_k^{i_k > 0}} \dots \\
 &= \sum_{\left[ \begin{array}{l} (\tau_0, \tau_1, \dots, \tau_k) \\ \text{where } \tau_0=1, \tau_k=0 \\ \tau_j=i_j, j=1, \dots, k-1 \\ \text{and } (i_1, i_2, \dots, i_k) \in S_k^{i_k=0} \end{array} \right]} (-1)^{q_{k+1}(\tau_0, \tau_1, \dots, \tau_k)} \prod_{j=0}^k \frac{x_j^{\tau_j}}{\tau_j!} \\
 &\quad + \sum_{\left[ \begin{array}{l} (\tau_0, \tau_1, \dots, \tau_k) \\ \text{where } \tau_0=1, \tau_k > 0 \\ \tau_j=i_j, j=1, \dots, k-1 \\ \text{and } (i_1, i_2, \dots, i_k) \in S_k^{i_k > 0} \end{array} \right]} (-1)^{q_{k+1}(\tau_0, \tau_1, \dots, \tau_k)} \prod_{j=0}^k \frac{x_j^{\tau_j}}{\tau_j!}
 \end{aligned}$$

Putting both results together then yields

$$\begin{aligned}
 &x_0 \left\{ p_k(x_0, x_1, \dots, x_{k-1}) - p_k(x_1, x_2, \dots, x_k) \right\} \\
 &= \sum_{(\tau_0, \tau_1, \dots, \tau_k) \in S_{k+1}^{\tau_0 > 1}} (-1)^{q_{k+1}(\tau_0, \tau_1, \dots, \tau_k)} \tau_0 \prod_{j=0}^k \frac{x_j^{\tau_j}}{\tau_j!} + \sum_{(\tau_0, \tau_1, \dots, \tau_k) \in S_{k+1}^{\tau_0=1}} (-1)^{q_{k+1}(\tau_0, \tau_1, \dots, \tau_k)} \prod_{j=0}^k \frac{x_j^{\tau_j}}{\tau_j!} \\
 &= \sum_{(\tau_0, \tau_1, \dots, \tau_k) \in S_{k+1}^{\tau_0 > 0}} (-1)^{q_{k+1}(\tau_0, \tau_1, \dots, \tau_k)} \tau_0 \prod_{j=0}^k \frac{x_j^{\tau_j}}{\tau_j!}.
 \end{aligned}$$

Analogous reasoning for  $1 \leq m \leq k$  gives

$$\begin{aligned}
 &x_m \left\{ p_k(x_{(m \bmod k+1)}, \dots, x_{(m+k-1 \bmod k+1)}) - p_k(x_{(m+1 \bmod k+1)}, \dots, x_{(m+k \bmod k+1)}) \right\} \\
 &= \sum_{(\tau_0, \tau_1, \dots, \tau_k) \in S_{k+1}^{\tau_m > 0}} (-1)^{q_{k+1}(\tau_0, \tau_1, \dots, \tau_k)} \tau_m \prod_{j=0}^k \frac{x_j^{\tau_j}}{\tau_j!},
 \end{aligned}$$

and therefore, since  $\tau_0 + \tau_1 + \dots + \tau_k = k + 1$  for  $(\tau_0, \tau_1, \dots, \tau_k) \in S_{k+1}$ ,

$$\begin{aligned}
 &\frac{1}{k+1} \sum_{m=0}^k x_m \left\{ p_k(x_{(m \bmod k+1)}, \dots, x_{(m+k-1 \bmod k+1)}) \right. \\
 &\quad \left. - p_k(x_{(m+1 \bmod k+1)}, \dots, x_{(m+k \bmod k+1)}) \right\}
 \end{aligned}$$

$$\begin{aligned}
&= \frac{1}{k+1} \sum_{m=0}^k \sum_{(\tau_0, \tau_1, \dots, \tau_k) \in S_{k+1}^{\tau_m > 0}} (-1)^{q_{k+1}(\tau_0, \tau_1, \dots, \tau_k)} \tau_m \prod_{j=0}^k \frac{x_j^{\tau_j}}{\tau_j!} \\
&= \frac{1}{k+1} \sum_{(\tau_0, \tau_1, \dots, \tau_k) \in S_{k+1}} (-1)^{q_{k+1}(\tau_0, \tau_1, \dots, \tau_k)} (\tau_0 + \tau_1 + \dots + \tau_k) \prod_{j=0}^k \frac{x_j^{\tau_j}}{\tau_j!} \\
&= \sum_{(\tau_0, \tau_1, \dots, \tau_k) \in S_{k+1}} (-1)^{q_{k+1}(\tau_0, \tau_1, \dots, \tau_k)} \prod_{j=0}^k \frac{x_j^{\tau_j}}{\tau_j!} = p_{k+1}(x_0, x_1, \dots, x_k).
\end{aligned}$$

□

The following properties of the polynomials  $p_k$  can now be stated as simple consequences of the preceding theorem.

**Corollary 1** *The polynomials  $p_k$ ,  $k \geq 1$ , are invariant with respect to circular permutation, i.e.*

$$p_k(x_0, x_1, \dots, x_{k-1}) = p_k(x_1, \dots, x_{k-1}, x_0), \quad (27)$$

for all  $x_0, x_1, \dots, x_{k-1} \in \mathbb{R}$ .

**Proof** Making direct use of (25) yields

$$\begin{aligned}
&p_{k+1}(x_1, \dots, x_k, x_0) \\
&= \frac{1}{k+1} \left\{ x_1(p_k(x_1, \dots, x_k) - p_k(x_2, \dots, x_k, x_0)) \right. \\
&\quad + x_2(p_k(x_2, \dots, x_k, x_0) - p_k(x_3, \dots, x_k, x_0, x_1)) \\
&\quad + \dots \\
&\quad \left. + x_0(p_k(x_0, x_1, \dots, x_{k-1}) - p_k(x_1, \dots, x_k)) \right\} \\
&= \frac{1}{k+1} \sum_{m=0}^k x_m \left\{ p_k(x_{(m \bmod k+1)}, \dots, x_{(m+k-1 \bmod k+1)}) \right. \\
&\quad \left. - p_k(x_{(m+1 \bmod k+1)}, \dots, x_{(m+k \bmod k+1)}) \right\} \\
&= p_{k+1}(x_0, x_1, \dots, x_k),
\end{aligned}$$

where only the order of summation has been rearranged to get the second equality. □

**Corollary 2** For all  $k \geq 1$  and  $x_0, x_1, \dots, x_k \in \mathbb{R}$ , the polynomials  $p_{k+1}(x_0, x_1, \dots, x_k)$  are translation-invariant, i.e. the equality

$$p_{k+1}(x_0, x_1, \dots, x_k) = p_{k+1}(x_0 + t, x_1 + t, \dots, x_k + t) \quad (28)$$

holds for all  $t \in \mathbb{R}$ .

**Proof** by induction with respect to  $k$ . Let  $k = 1$ . Then

$$\begin{aligned} p_2(x_0 + t, x_1 + t) &= \frac{1}{2}(x_0 + t)^2 + \frac{1}{2}(x_1 + t)^2 - (x_0 + t)(x_1 + t) \\ &= \frac{1}{2}x_0^2 + \frac{1}{2}x_1^2 - x_0x_1 = p_2(x_0, x_1). \end{aligned}$$

Now we assume the validity of statement (28) for some natural  $k \geq 1$ . Using representation (25) of Theorem 6 we get that

$$\begin{aligned} &p_{k+1}(x_0 + t, x_1 + t, \dots, x_k + t) \\ &= \frac{1}{k+1} \sum_{m=0}^k (x_m + t - x_{(m-1) \bmod k+1}) p_k(x_{(m \bmod k+1)} + t, \dots, x_{(m+k-1) \bmod k+1} + t) \\ &= \frac{1}{k+1} \sum_{m=0}^k (x_m - x_{(m-1) \bmod k+1}) p_k(x_{(m \bmod k+1)}, \dots, x_{(m+k-1) \bmod k+1}) \\ &= p_{k+1}(x_0, x_1, \dots, x_k), \end{aligned}$$

where the last but one equality follows from the induction hypothesis.  $\square$

The next property can immediately be seen from the definition of the polynomials but will be stated here for completeness reasons: For all  $k \geq 1$  and  $x_0, x_1, \dots, x_{k-1} \in \mathbb{R}$ ,

$$p_k(tx_0, tx_1, \dots, tx_{k-1}) = t^k p_k(x_0, x_1, \dots, x_{k-1}), \quad (29)$$

for all  $t \in \mathbb{R}$ .

## 4.2 Differences

As one can already suspect from looking at representation (26), polynomial differences play a very important role when investigating the polynomials  $p_k$ . Especially, when their explicit formula becomes too complex to overlook.

In order to get an idea what impact on the overall value of the polynomial the variation of a single argument has, the following result will be helpful.



**Theorem 7** For all  $k \geq 1$  and  $x_0, x_1, \dots, x_{k-1} \in \mathbb{R}$  the following equality holds:

$$\begin{aligned} & p_k(x_0, x_1, \dots, x_{k-1}) - p_k(0, x_1, \dots, x_{k-1}) \\ &= \frac{x_0^k}{k!} - \sum_{j=1}^{k-1} \frac{x_0^{k-j}}{(k-j)!} \left\{ p_j(x_1, x_2, \dots, x_j) - p_j(0, x_1, \dots, x_{j-1}) \right\}. \end{aligned} \quad (30)$$

**Proof** The summation in equation (9) of the definition of the polynomials  $p_k$  can be split into the following summands:

$$\begin{aligned} & p_k(x_0, x_1, \dots, x_{k-1}) \\ &= \sum_{(i_0, i_1, \dots, i_{k-1}) \in S_k^{i_0=0}} \dots + \sum_{(i_0, i_1, \dots, i_{k-1}) \in S_k^{i_0=1}} \dots + \dots + \sum_{(i_0, i_1, \dots, i_{k-1}) \in S_k^{i_0=k}} \dots \end{aligned}$$

Looking at the first sum yields the following reasoning. In order to get those terms belonging to the first sum, we have to take all the monomials of  $p_k(x_0, x_1, \dots, x_{k-1})$  and discard exactly those, which have  $i_0 > 0$ . But since the terms are products of powers of the  $x_i$ 's, this can precisely be achieved by setting  $x_0 = 0$ . Then all the monomials with  $i_0 > 0$  vanish and only those with  $i_0 = 0$  remain. Therefore

$$\sum_{(i_0, i_1, \dots, i_{k-1}) \in S_k^{i_0=0}} (-1)^{q_k(i_0, i_1, \dots, i_{k-1})} \prod_{n=0}^{k-1} \frac{x_n^{i_n}}{i_n!} = p_k(0, x_1, \dots, x_{k-1}).$$

It is very easy to see that

$$\sum_{(i_0, i_1, \dots, i_{k-1}) \in S_k^{i_0=k}} (-1)^{q_k(i_0, i_1, \dots, i_{k-1})} \prod_{n=0}^{k-1} \frac{x_n^{i_n}}{i_n!} = \frac{x_0^k}{k!},$$

because  $S_k^{i_0=k} = \{(k, 0, 0, \dots, 0)\}$ .

Now let us look at the case  $i_0 = j$ , where  $j \in \{1, \dots, k-1\}$ . We see that

$$\begin{aligned} & \sum_{(i_0, i_1, \dots, i_{k-1}) \in S_k^{i_0=j}} (-1)^{q_k(i_0, i_1, \dots, i_{k-1})} \prod_{n=0}^{k-1} \frac{x_n^{i_n}}{i_n!} \\ &= \sum_{\substack{(j, i_1, \dots, i_{k-j}, 0, \dots, 0) \\ j-1}} (-1)^{q_k(j, i_1, \dots, i_{k-j}, \underbrace{0, \dots, 0}_{j-1})} \frac{x_0^j}{j!} \prod_{n=1}^{k-j} \frac{x_n^{i_n}}{i_n!} \prod_{n=k-j+1}^{k-1} \frac{x_n^0}{0!} \\ &= \frac{x_0^j}{j!} \sum_{(i_1, \dots, i_{k-j}) \in S_{k-j}^{i_{k-j} > 0}} (-1)^{q_{k-j}(i_1, \dots, i_{k-j})+1} \prod_{n=1}^{k-j} \frac{x_n^{i_n}}{i_n!} \end{aligned}$$

$$\begin{aligned}
&= -\frac{x_0^j}{j!} \left\{ \sum_{(i_1, \dots, i_{k-j}) \in S_{k-j}} (-1)^{q_{k-j}(i_1, \dots, i_{k-j})} \prod_{n=1}^{k-j} \frac{x_n^{i_n}}{i_n!} \right. \\
&\quad \left. - \sum_{(i_1, \dots, i_{k-j}) \in S_{k-j}^{i_{k-j}=0}} (-1)^{q_{k-j}(i_1, \dots, i_{k-j})} \prod_{n=1}^{k-j} \frac{x_n^{i_n}}{i_n!} \right\} \\
&= -\frac{x_0^j}{j!} \left\{ p_{k-j}(x_1, \dots, x_{k-j}) - p_{k-j}(x_1, \dots, x_{k-j-1}, 0) \right\}.
\end{aligned}$$

Using the invariance-property stated in Corollary 1 and putting all the different cases together proves the theorem.  $\square$

If the arguments of such polynomial differences considered in Theorem 7 have a certain structure, the resulting expansion may simplify significantly. Two important cases which we will need in the proofs later on are considered in the next corollaries.

**Corollary 3** For all  $k, m \in \mathbb{N}_0$  and  $x_0, x_1, \dots, x_k \in \mathbb{R}$  the following equality holds:

$$\begin{aligned}
&p_{k+m+1}(\underbrace{0, \dots, 0}_m, x_0, x_1, \dots, x_k) - p_{k+m+1}(\underbrace{0, \dots, 0}_{m+1}, x_1, \dots, x_k) \\
&= \frac{x_0^{k+m+1}}{(k+m+1)!} - \sum_{j=1}^k \frac{x_0^{k+m+1-j}}{(k+m+1-j)!} \left\{ p_j(x_1, x_2, \dots, x_j) - p_j(0, x_1, \dots, x_{j-1}) \right\}. \quad (31)
\end{aligned}$$

**Proof** We first realize that due to the translation-invariance property of the polynomials  $p_k$  we can rewrite the lefthand side of (31) according to

$$\begin{aligned}
&p_{k+m+1}(\underbrace{0, \dots, 0}_m, x_0, x_1, \dots, x_k) - p_{k+m+1}(\underbrace{0, \dots, 0}_{m+1}, x_1, \dots, x_k) \\
&= p_{k+m+1}(\tilde{x}_0, \tilde{x}_1, \dots, \tilde{x}_{k+m}) - p_{k+m+1}(0, \tilde{x}_1, \dots, \tilde{x}_{k+m}),
\end{aligned}$$

if we call  $\tilde{x}_j = x_j$  for  $j = 0, \dots, k$  and  $\tilde{x}_j = 0$  for  $j = k+1, \dots, k+m$ . But this allows us to apply Theorem 7 to obtain

$$\begin{aligned}
&p_{k+m+1}(\tilde{x}_0, \tilde{x}_1, \dots, \tilde{x}_{k+m}) - p_{k+m+1}(0, \tilde{x}_1, \dots, \tilde{x}_{k+m}) \\
&= \frac{\tilde{x}_0^{k+m+1}}{(k+m+1)!} - \sum_{j=1}^{k+m} \frac{\tilde{x}_0^j}{j!} \left\{ p_{k+m+1-j}(\tilde{x}_1, \tilde{x}_2, \dots, \tilde{x}_{k+m+1-j}) \right. \\
&\quad \left. - p_{k+m+1-j}(0, \tilde{x}_1, \dots, \tilde{x}_{k+m-j}) \right\}
\end{aligned}$$

$$= \frac{x_0^{k+m+1}}{(k+m+1)!} - \sum_{j=m+1}^{k+m} \frac{x_0^j}{j!} \left\{ p_{k+m+1-j}(x_1, x_2, \dots, x_{k+m+1-j}) \right. \\ \left. - p_{k+m+1-j}(0, x_1, \dots, x_{k+m-j}) \right\},$$

where we used the fact that for  $j \leq m$  we have  $k+m+1-j \geq k+1$  and thus

$$p_{k+m+1-j}(\tilde{x}_1, \tilde{x}_2, \dots, \tilde{x}_{k+m+1-j}) = p_{k+m+1-j}(x_1, x_2, \dots, x_k, \underbrace{0, \dots, 0}_{m+1-j}) \\ = p_{k+m+1-j}(0, x_1, x_2, \dots, x_k, \underbrace{0, \dots, 0}_{m-j}) = p_{k+m+1-j}(0, \tilde{x}_1, \tilde{x}_2, \dots, \tilde{x}_{k+m-j}).$$

If we substitute  $j$  by  $m+j+1$  we get the statement of this corollary.  $\square$

**Corollary 4** For all  $k, m \in \mathbb{N}_0$  and  $x_0, x_1, \dots, x_m \in \mathbb{R}$  the following equality holds:

$$p_{k+1}(x_0, \dots, x_{m-1}, x_m, 1, \dots, k-m) - p_{k+1}(x_0, \dots, x_{m-1}, 0, 1, \dots, k-m) \\ = \left\{ p_{k+1}(x_0, \dots, x_{m-1}, x_m, \underbrace{0, \dots, 0}_{k-m}) - p_{k+1}(x_0, \dots, x_{m-1}, \underbrace{0, \dots, 0}_{k+1-m}) \right\} \\ - \left\{ p_k(x_0, \dots, x_{m-1}, x_m, \underbrace{0, \dots, 0}_{k-m-1}) - p_k(x_0, \dots, x_{m-1}, \underbrace{0, \dots, 0}_{k-m}) \right\} \quad (32)$$

**Proof** by induction with respect to  $k$ . We first apply Corollary 1 to reorder the arguments of the polynomials on the lefthand side of (32) so as to apply Theorem 7.

$$p_{k+1}(x_0, \dots, x_{m-1}, x_m, 1, \dots, k-m) - p_{k+1}(x_0, \dots, x_{m-1}, 0, 1, \dots, k-m) \\ = p_{k+1}(x_m, 1, \dots, k-m, x_0, \dots, x_{m-1}) - p_{k+1}(0, 1, \dots, k-m, x_0, \dots, x_{m-1}) \\ = \frac{x_m^{k+1}}{(k+1)!} - \frac{x_m^k}{k!} - \sum_{j=1}^m \frac{x_m^j}{j!} \left\{ p_{k+1-j}(1, \dots, k-m, x_0, \dots, x_{m-j}) \right. \\ \left. - p_{k+1-j}(0, 1, \dots, k-m, x_0, \dots, x_{m-j-1}) \right\},$$

where we used the fact that  $p_1(1) - p_1(0) = 1$ . Due to translation-invariance property (28) we used that  $p_j(1, \dots, j) - p_j(0, 1, \dots, j-1) = 0$  to omit all terms with  $j = m+1, \dots, k-1$ . After another reordering of the arguments of the polynomials, we use the induction hypothesis on the differences in the last line above and obtain

$$p_{k+1}(x_0, \dots, x_{m-1}, x_m, 1, \dots, k-m) - p_{k+1}(x_0, \dots, x_{m-1}, 0, 1, \dots, k-m)$$

$$\begin{aligned}
&= \frac{x_m^{k+1}}{(k+1)!} - \sum_{j=1}^m \frac{x_m^j}{j!} \left\{ p_{k+1-j}(x_0, \dots, x_{m-j}, \underbrace{0, \dots, 0}_{k-m}) - p_{k+1-j}(x_0, \dots, x_{m-j-1}, \underbrace{0, \dots, 0}_{k+1-m}) \right\} \\
&\quad - \left\{ \frac{x_m^k}{k!} - \sum_{j=1}^m \frac{x_m^j}{j!} \left\{ p_{k-j}(x_0, \dots, x_{m-j}, \underbrace{0, \dots, 0}_{k-m-1}) - p_{k-j}(x_0, \dots, x_{m-j-1}, \underbrace{0, \dots, 0}_{k-m}) \right\} \right\} \\
&= p_{k+1}(x_0, \dots, x_{m-1}, x_m, \underbrace{0, \dots, 0}_{k-m}) - p_{k+1}(x_0, \dots, x_{m-1}, \underbrace{0, \dots, 0}_{k+1-m}) \\
&\quad - \left\{ p_k(x_0, \dots, x_{m-1}, x_m, \underbrace{0, \dots, 0}_{k-m-1}) - p_k(x_0, \dots, x_{m-1}, \underbrace{0, \dots, 0}_{k-m}) \right\},
\end{aligned}$$

where we can give the same arguments as before to rebuild the differences according to Theorem 7.  $\square$

Sometimes it is helpful to use a representation slightly different from the expansion stated in Theorem 7. Since the next result can be proved following the same lines as given for Theorem 7 with only minor modifications, an explicit proof is omitted here.

**Theorem 8** For all  $k \geq 0$  and  $x_0, x_1, \dots, x_k \in \mathbb{R}$  the following equality holds:

$$\begin{aligned}
&p_{k+1}(x_0, \dots, x_{k-1}, x_k) - p_k(x_0, \dots, x_{k-1}, 0) \\
&= \frac{x_k^{k+1}}{(k+1)!} - \sum_{j=1}^k \frac{(x_{k-j})^{k+1-j}}{(k+1-j)!} \left\{ p_j(x_{k+1-j}, \dots, x_k) - p_j(x_{k+1-j}, \dots, x_{k-1}, 0) \right\}. \tag{33}
\end{aligned}$$

Having this result we can state yet another recurrence representation of the polynomials  $p_k$ .

**Theorem 9** For all  $x_0, x_1, \dots, x_m \in \mathbb{R}$ ,  $0 \leq m \leq k-1$  and  $k \in \mathbb{N}$  the following equality holds:

$$\begin{aligned}
&p_{k+1}(x_0, \dots, x_{m-1}, x_m, 1, \dots, k-m) - p_{k+1}(x_0, \dots, x_{m-1}, 0, 1, \dots, k-m) \\
&= h_{k+1}(x_m) - \sum_{j=0}^{m-1} \left\{ p_{j+1}(x_{m-j}, \dots, x_m) - p_{j+1}(0, x_{m-j}, \dots, x_{m-1}) \right\} h_{k-j}(x_{m-1-j}),
\end{aligned}$$

where the family of functions  $h_j : \mathbb{R} \rightarrow \mathbb{R}$ ,  $j \in \{\dots, -1, 0, 1, 2, \dots\}$ , is given by

$$h_j(x) = \begin{cases} \frac{x^j}{j!} - \frac{x^{j-1}}{(j-1)!}, & j \geq 1, \\ 1, & j = 0, \\ 0, & \text{otherwise.} \end{cases} \tag{34}$$

**Proof** > From Corollary 4 we know that

$$\begin{aligned} & p_{k+1}(x_0, \dots, x_{m-1}, x_m, 1, \dots, k-m) - p_{k+1}(x_0, \dots, x_{m-1}, 0, 1, \dots, k-m) \\ &= \left\{ p_{k+1}(x_0, \dots, x_{m-1}, x_m, \underbrace{0, \dots, 0}_{k-m}) - p_{k+1}(x_0, \dots, x_{m-1}, \underbrace{0, \dots, 0}_{k+1-m}) \right\} \end{aligned} \quad (35)$$

$$- \left\{ p_k(x_0, \dots, x_{m-1}, x_m, \underbrace{0, \dots, 0}_{k-m-1}) - p_k(x_0, \dots, x_{m-1}, \underbrace{0, \dots, 0}_{k-m}) \right\}. \quad (36)$$

Let us first focus on difference (35) above. We use translation-invariance property (28) to reorder the arguments of the polynomials to be able to apply Theorem 8 to this difference and obtain

$$\begin{aligned} & p_{k+1}(x_0, \dots, x_{m-1}, x_m, \underbrace{0, \dots, 0}_{k-m}) - p_{k+1}(x_0, \dots, x_{m-1}, \underbrace{0, \dots, 0}_{k+1-m}) \\ &= p_{k+1}(\underbrace{0, \dots, 0}_{k-m}, x_0, \dots, x_{m-1}, x_m) - p_{k+1}(\underbrace{0, \dots, 0}_{k-m}, x_0, \dots, x_{m-1}, 0) \\ &= \frac{x_m^{k+1}}{(k+1)!} - \sum_{j=1}^m \frac{x_m^{k+1-j}}{(k+1-j)!} \left\{ p_j(x_{m+1-j}, \dots, x_m) - p_j(x_{m+1-j}, \dots, x_{m-1}, 0) \right\}, \end{aligned}$$

where we used that the summands are equal to zero for  $j = m+1, \dots, k$  due to the zero factor that shows up in these cases. For difference (36) we get the same expression except for having  $k$  instead of  $k+1$ . Putting these results together finally leads to

$$\begin{aligned} & p_{k+1}(x_0, \dots, x_{m-1}, x_m, 1, \dots, k-m) - p_{k+1}(x_0, \dots, x_{m-1}, 0, 1, \dots, k-m) \\ &= \frac{x_m^{k+1}}{(k+1)!} - \frac{x_m^k}{k!} - \sum_{j=1}^m \left\{ p_j(x_{m+1-j}, \dots, x_m) - p_j(x_{m+1-j}, \dots, x_{m-1}, 0) \right\} \\ & \quad \cdot \left\{ \frac{(x_{m-j})^{k+1-j}}{(k+1-j)!} - \frac{(x_{m-j})^{k-j}}{(k-j)!} \right\}, \end{aligned}$$

which is the statement of the theorem if we shift the summation index  $j$  by one and use the definition of the functions  $h_j(x)$ .  $\square$

Little extra effort is necessary to prove the next result which turns out to be the key representation formula for the proof of Theorem 5.

**Theorem 10** *Let  $k \in \mathbb{N}$  and  $m \in \mathbb{N}_0$ . For all  $x_0, x_1, \dots, x_m \in \mathbb{R}$ , the following equality holds:*

$$\begin{aligned} & p_k(x_0, x_1, \dots, x_m, m+1, \dots, k-1) - p_k(x_1, \dots, x_m, m+1, \dots, k) \\ &= h_k(x_0) - \sum_{j=1}^m \left\{ p_j(x_1, \dots, x_j) - p_j(j, x_1, \dots, x_{j-1}) \right\} h_{k-j}(x_0 - j), \end{aligned} \quad (37)$$

where the functions  $h_j(\cdot)$  are defined according to (34).

**Proof** We first want to consider the non-degenerate case, that is  $m < k$ . The main idea is to split up each of the polynomials into a telescopic sum.

$$\begin{aligned}
& p_k(x_0, x_1, \dots, x_m, m+1, \dots, k-1) - p_k(x_1, \dots, x_m, m+1, \dots, k) \\
&= \sum_{j=0}^m \left\{ p_k(x_0, \dots, x_j, j+1, \dots, k-1) - p_k(x_0, \dots, x_{j-1}, j, \dots, k-1) \right\} \\
&\quad - \sum_{j=1}^m \left\{ p_k(x_1, \dots, x_j, j+1, \dots, k) - p_k(x_1, \dots, x_{j-1}, j, \dots, k) \right\} \\
&= \sum_{j=0}^m \left\{ p_k(x_0 - j, \dots, x_j - j, 1, \dots, k - j - 1) - p_k(x_0 - j, \dots, x_{j-1} - j, 0, \dots, k - j - 1) \right\} \\
&\quad - \sum_{j=1}^m \left\{ p_k(x_1 - j, \dots, x_j - j, 1, \dots, k - j) - p_k(x_1 - j, \dots, x_{j-1} - j, 0, \dots, k - j) \right\},
\end{aligned}$$

where we used the translation-invariance property of the polynomials  $p_k$  to bring the single differences of these polynomials into a form where Theorem 9 can be applied. Thus,

$$\begin{aligned}
& p_k(x_0, x_1, \dots, x_m, m+1, \dots, k-1) - p_k(x_1, \dots, x_m, m+1, \dots, k) \\
&= \sum_{j=0}^m \left\{ h_k(x_j - j) - \sum_{l=1}^j \left\{ p_l(x_{j+1-l} - j, \dots, x_j - j) - p_l(0, x_{j+1-l} - j, \dots, x_{j-1} - j) \right\} \right. \\
&\quad \left. h_{k-l}(x_{j-l} - j) \right\} \\
&\quad - \sum_{j=1}^m \left\{ h_k(x_j - j) - \sum_{l=1}^{j-1} \left\{ p_l(x_{j+1-l} - j, \dots, x_j - j) - p_l(0, x_{j+1-l} - j, \dots, x_{j-1} - j) \right\} \right. \\
&\quad \left. h_{k-l}(x_{j-l} - j) \right\} \\
&= h_k(x_0) - \sum_{j=1}^m \left\{ p_j(x_1 - j, \dots, x_j - j) - p_j(0, x_1 - j, \dots, x_{j-1} - j) \right\} h_{k-j}(x_0 - j).
\end{aligned}$$

Shifting all the arguments of the polynomials  $p_j$  by  $j$  finally yields (37). In case  $m \geq k$ , we actually mean the difference  $p_k(x_0, x_1, \dots, x_{k-1}) - p_k(x_1, \dots, x_k)$ . Thus, the arguments given above remain valid with the summations ranging to  $k$  instead of  $m$ . But because of the way we defined  $h_j(x)$  for  $j < 0$  we can also let the summation range to  $m$  instead of  $k$  without changing the result.  $\square$

## 5 Proof of Theorem 3 and 4

We are now in a position to give the proofs of Theorem 3 and 4. Since the sequence  $\{D_n\}$  is independent of the Poisson process  $\{T_n\}$ , we will assume for the moment that the sequence  $\{D_n\}$  is deterministic. We then get the stochastic formulas of these two theorems by integrating our results w.r.t. the law of the sequence  $\{D_n\}$ .

### 5.1 Proof of Theorem 3

To simplify notation we define  $x_j = D_j - D_n$ , for  $j = 0, \dots, n-1$ . Before we look at  $R_{n+1}$  as defined in (14), we notice that we can represent the polynomials  $p_k$  as follows:

$$\begin{aligned} p_{k+1}(z_0, \dots, z_{n-1}, \underbrace{0, \dots, 0}_{k+1-n}) &= p_{k+1}(\underbrace{0, \dots, 0}_{k+1-n}, z_0, \dots, z_{n-1}) \\ &= \sum_{m=0}^{n-1} \left\{ p_{k+1}(\underbrace{0, \dots, 0}_{k-n+m+1}, z_m, \dots, z_{n-1}) - p_{k+1}(\underbrace{0, \dots, 0}_{k-n+m+2}, z_{m+1}, \dots, z_{n-1}) \right\}. \end{aligned} \quad (38)$$

Thus, with the usual convention that  $\sum_a^b = 0$  whenever  $b < a$ , and using Corollary 3 for the second step, we obtain

$$\begin{aligned} &\sum_{k=n+1}^{\infty} p_{k+1}(\lambda x_0, \dots, \lambda x_{n-1}, \underbrace{0, \dots, 0}_{k+1-n}) \\ &= \sum_{k=n+1}^{\infty} \sum_{m=0}^{n-1} \left\{ p_{k+1}(\underbrace{0, \dots, 0}_{k-n+m+1}, \underbrace{\lambda x_m, \dots, \lambda x_{n-1}}_{n-m}) - p_{k+1}(\underbrace{0, \dots, 0}_{k-n+m+2}, \underbrace{\lambda x_{m+1}, \dots, \lambda x_{n-1}}_{n-m-1}) \right\} \\ &= \sum_{k=n+1}^{\infty} \sum_{m=0}^{n-1} \left\{ \frac{(\lambda x_m)^{k+1}}{(k+1)!} - \sum_{j=1}^{n-m-1} \frac{(\lambda x_m)^{k+1-j}}{(k+1-j)!} \cdot \left\{ p_j(\lambda x_{m+1}, \dots, \lambda x_{m+j}) - p_j(0, \lambda x_{m+1}, \dots, \lambda x_{m+j-1}) \right\} \right\} \\ &= \sum_{m=0}^{n-1} \left\{ \sum_{k=n+2}^{\infty} \frac{(\lambda x_m)^k}{k!} - \sum_{j=1}^{n-1-m} \left( \sum_{k=n+2-j}^{\infty} \frac{(\lambda x_m)^k}{k!} \right) \cdot \left\{ p_j(\lambda x_{m+1}, \dots, \lambda x_{m+j}) - p_j(0, \lambda x_{m+1}, \dots, \lambda x_{m+j-1}) \right\} \right\} \\ &= \sum_{m=0}^{n-1} \mathcal{T}_{n+1}(e^{\lambda x_m}) - \sum_{m=0}^{n-2} \sum_{j=1}^{n-1-m} \lambda^j \mathcal{T}_{n+1-j}(e^{\lambda x_m}) \left\{ p_j(x_{m+1}, \dots, x_{m+j}) \right\} \end{aligned}$$

$$- p_j(0, x_{m+1}, \dots, x_{m+j-1}) \Big\}.$$

This completes the proof of Theorem 3.

## 5.2 Proof of Theorem 4

To get representation (17) as stated in Theorem 4 we have to choose another way to look at the remainder  $R_{n+1}$ .

$$\begin{aligned} R_{n+1} &= \sum_{m=0}^{n-1} \left( e^{\lambda x_m} - \sum_{i=0}^{n+1} \lambda^i \frac{x_m^i}{i!} \right) - \sum_{m=0}^{n-2} \sum_{j=1}^{n-1-m} \lambda^j \left( e^{\lambda x_m} - \sum_{i=0}^{n+1-j} \lambda^i \frac{x_m^i}{i!} \right) \\ &\quad \cdot \left\{ p_j(x_{m+1}, \dots, x_{m+j}) - p_j(0, x_{m+1}, \dots, x_{m+j-1}) \right\} \\ &= \sum_{m=0}^{n-1} \left\{ e^{\lambda x_m} - 1 \right\} - \sum_{i=1}^{n+1} \lambda^i \sum_{m=0}^{n-1} \frac{x_m^i}{i!} \\ &\quad - \sum_{m=0}^{n-2} \sum_{j=1}^{n-1-m} \lambda^j e^{\lambda x_m} \left\{ p_j(x_{m+1}, \dots, x_{m+j}) - p_j(0, x_{m+1}, \dots, x_{m+j-1}) \right\} \\ &\quad + \sum_{m=0}^{n-2} \sum_{j=1}^{n-1-m} \lambda^j \sum_{i=0}^{n+1-j} \lambda^i \frac{x_m^i}{i!} \left\{ p_j(x_{m+1}, \dots, x_{m+j}) - p_j(0, x_{m+1}, \dots, x_{m+j-1}) \right\} \quad (39) \\ &= \text{I} - \text{II} - \text{III} + \text{IV}, \end{aligned}$$

where we naturally defined I, II, III and IV to be equal to the more complex summations showing up in (39). We first want to focus on expression III. An interchange of summation gives

$$\text{III} = \sum_{j=1}^{n-1} \lambda^j \sum_{m=0}^{n-1-j} e^{\lambda x_m} \left\{ p_j(x_{m+1}, \dots, x_{m+j}) - p_j(0, x_{m+1}, \dots, x_{m+j-1}) \right\}. \quad (40)$$

A few more steps have to be taken to rewrite IV to an appropriate form. As we just did we first interchange those summations involving  $m$  and  $j$ . Then we also interchange those involving  $m$  and  $i$  which results in

$$\begin{aligned} \text{IV} &= \sum_{j=1}^{n-1} \sum_{i=0}^{n+1-j} \lambda^{i+j} \sum_{m=0}^{n-1-j} \frac{x_m^i}{i!} \left\{ p_j(x_{m+1}, \dots, x_{m+j}) - p_j(0, x_{m+1}, \dots, x_{m+j-1}) \right\} \\ &= \sum_{i=1}^{n-1} \lambda^i \sum_{j=1}^i \sum_{m=0}^{n-1-j} \frac{x_m^{i-j}}{(i-j)!} \left\{ p_j(x_{m+1}, \dots, x_{m+j}) - p_j(0, x_{m+1}, \dots, x_{m+j-1}) \right\} \quad (41) \end{aligned}$$

$$+ \sum_{i=n}^{n+1} \lambda^i \sum_{j=1}^i \sum_{m=0}^{n-1-j} \frac{x_m^{i-j}}{(i-j)!} \left\{ p_j(x_{m+1}, \dots, x_{m+j}) - p_j(0, x_{m+1}, \dots, x_{m+j-1}) \right\}, \quad (42)$$



where we substituted  $i \rightarrow i - j$ , then split up the summation into two expressions and finally interchanged those summations involving  $j$  and  $i$  in both expressions to come up with the second equality. Next, we split up (41) into two parts to be able to interchange the summation over  $j$  and  $m$ , which we also do for expression (42).

$$\text{IV} = \sum_{i=1}^{n-1} \lambda^i \sum_{m=0}^{n-1-i} \sum_{j=1}^i \frac{x_m^{i-j}}{(i-j)!} \left\{ p_j(x_{m+1}, \dots, x_{m+j}) - p_j(0, x_{m+1}, \dots, x_{m+j-1}) \right\} \quad (43)$$

$$+ \sum_{i=1}^{n-1} \lambda^i \sum_{m=n-i}^{n-2} \sum_{j=1}^{n-1-m} \frac{x_m^{i-j}}{(i-j)!} \left\{ p_j(x_{m+1}, \dots, x_{m+j}) - p_j(0, x_{m+1}, \dots, x_{m+j-1}) \right\} \quad (44)$$

$$+ \lambda^n \sum_{m=0}^{n-2} \sum_{j=1}^{n-1-m} \frac{x_m^{n-j}}{(n-j)!} \left\{ p_j(x_{m+1}, \dots, x_{m+j}) - p_j(0, x_{m+1}, \dots, x_{m+j-1}) \right\} \quad (45)$$

$$+ \lambda^{n+1} \sum_{m=0}^{n-2} \sum_{j=1}^{n-1-m} \frac{x_m^{n+1-j}}{(n+1-j)!} \left\{ p_j(x_{m+1}, \dots, x_{m+j}) - p_j(0, x_{m+1}, \dots, x_{m+j-1}) \right\}. \quad (46)$$

Note, that we can formally allow  $m$  to range to  $n - 1$  instead of  $n - 2$  in (44), (45) and (46) without changing the value of IV. Furthermore, (44) and (45) can be combined to one summation over  $i$  ranging from 1 to  $n$ . Using this representation of IV we split up II accordingly to calculate

$$\begin{aligned} \text{II} - \text{IV} &= \sum_{i=1}^n \lambda^i \left\{ \sum_{m=0}^{n-1-i} \left\{ \frac{x_m^i}{i!} - \sum_{j=1}^i \frac{x_m^{i-j}}{(i-j)!} \left\{ p_j(x_{m+1}, \dots, x_{m+j}) \right. \right. \right. \\ &\quad \left. \left. \left. - p_j(0, x_{m+1}, \dots, x_{m+j-1}) \right\} \right\} \right\} \\ &\quad + \sum_{m=n-i}^{n-1} \left\{ \frac{x_m^i}{i!} - \sum_{j=1}^{n-1-m} \frac{x_m^{i-j}}{(i-j)!} \left\{ p_j(x_{m+1}, \dots, x_{m+j}) \right. \right. \\ &\quad \left. \left. \left. - p_j(0, x_{m+1}, \dots, x_{m+j-1}) \right\} \right\} \right\} \\ &\quad + \lambda^{n+1} \sum_{m=0}^{n-1} \left\{ \frac{x_m^{n+1}}{(n+1)!} - \sum_{j=1}^{n-1-m} \frac{x_m^{n+1-j}}{(n+1-j)!} \left\{ p_j(x_{m+1}, \dots, x_{m+j}) \right. \right. \\ &\quad \left. \left. \left. - p_j(0, x_{m+1}, \dots, x_{m+j-1}) \right\} \right\} \right\} \\ &= \sum_{i=1}^n \lambda^i \left\{ \sum_{m=0}^{n-1-i} \left\{ p_i(x_m, \dots, x_{m+i-1}) - p_i(x_{m+1}, \dots, x_{m+i}) \right\} \right. \\ &\quad \left. + \sum_{m=n-i}^{n-1} \left\{ p_i(\underbrace{0, \dots, 0}_{m+i-n}, x_m, \dots, x_{n-1}) - p_i(\underbrace{0, \dots, 0}_{m+i-n+1}, x_{m+1}, \dots, x_{n-1}) \right\} \right\} \end{aligned}$$

$$\begin{aligned}
& + \lambda^{n+1} \sum_{m=0}^{n-1} \left\{ p_{n+1}(\underbrace{0, \dots, 0}_{m+1}, x_m, \dots, x_{n-1}) - p_{n+1}(\underbrace{0, \dots, 0}_{m+2}, x_{m+1}, \dots, x_{n-1}) \right\} \\
& = \sum_{i=1}^n \lambda^i p_i(x_0, \dots, x_{i-1}) + \lambda^{n+1} p_{n+1}(0, x_0, \dots, x_{n-1}),
\end{aligned}$$

where the first part of the second equality follows from Theorem 7 by noting that

$$\begin{aligned}
& \frac{x_m^i}{i!} - \sum_{j=1}^i \frac{x_m^{i-j}}{(i-j)!} \left\{ p_j(x_{m+1}, \dots, x_{m+j}) - p_j(0, x_{m+1}, \dots, x_{m+j-1}) \right\} \\
& = \frac{x_m^i}{i!} - \sum_{j=1}^{i-1} \frac{x_m^{i-j}}{(i-j)!} \left\{ p_j(x_{m+1}, \dots, x_{m+j}) - p_j(0, x_{m+1}, \dots, x_{m+j-1}) \right\} \\
& \quad - \left\{ p_i(x_{m+1}, \dots, x_{m+i}) - p_i(0, x_{m+1}, \dots, x_{m+i-1}) \right\} \\
& = \left\{ p_i(x_m, \dots, x_{m+i-1}) - p_i(0, x_{m+1}, \dots, x_{m+i-1}) \right\} \\
& \quad - \left\{ p_i(x_{m+1}, \dots, x_{m+i}) - p_i(0, x_{m+1}, \dots, x_{m+i-1}) \right\}
\end{aligned}$$

for all  $m = 0, \dots, n-1-i$ , and  $i = 1, \dots, n$ , whereas the second and third part of this equality are direct consequences of Corollary 3. Resubstituting  $D_j - D_n$  for  $x_j$ ,  $j = 0, \dots, n-1$ , and using the translation-invariance property (28) of the polynomials  $p_k$  finally yields

$$\text{II} - \text{IV} = -\lambda D_n + \sum_{i=1}^{n+1} \lambda^i p_i(D_0, \dots, D_{i-1}),$$

and therefore

$$\begin{aligned}
R_{n+1} & = \sum_{m=0}^{n-1} \left\{ e^{\lambda(D_m - D_n)} - 1 \right\} + \lambda D_n - \sum_{i=0}^n \lambda^{i+1} p_{i+1}(D_0, \dots, D_i) \\
& \quad - \sum_{j=1}^{n-1} \lambda^j \sum_{m=0}^{n-1-j} e^{\lambda(D_m - D_n)} \left\{ p_j(D_{m+1}, \dots, D_{m+j}) - p_j(D_{m+1}, \dots, D_{m+j-1}, D_n) \right\},
\end{aligned} \tag{47}$$

which proves Theorem 4.  $\square$

## 6 Proof of Theorem 5

Our starting-point is the following modification of statement (17) of Theorem 4 for the expectation of the transient waiting time of the  $n + 1$ -th customer:

$$\mathbb{E}\left[W_{n+1}\right] = \frac{1}{\lambda} \left\{ \sum_{m=1}^n e^{-\lambda(D_n - D_{n-m})} - n + \lambda D_n + \sum_{m=2}^n e^{-\lambda(D_n - D_{n-m})} \sum_{j=1}^{m-1} \lambda^j \cdot \left\{ p_j(D_n, D_{n-m+1}, \dots, D_{n-m+j-1}) - p_j(D_{n-m+1}, \dots, D_{n-m+j}) \right\} \right\}. \quad (48)$$

Remember that in this section we assume that  $D_0, D_1, \dots$  is a deterministic sequence having a special structure, see (20), that originates from a  $(\max, +)$ -linear systems with deterministic services. The most simple system in this class of networks is the M/D/1 queue. We will therefore investigate this system first with respect to the formulas derived so far, and later extend this result to more general deterministic  $(\max, +)$ -linear systems.

### 6.1 The M/D/1 Queue

The M/G/1 queue can be modelled as an open  $(\max, +)$ -linear system with Poisson input. The variables  $D_n$  are then given by  $D_0 = 0$  and  $D_n = \sum_{j=1}^n \sigma_j$ , where  $\sigma_j$  is the service time of the  $j$ -th arriving customer, see, for example, section 4.2.1 of [3]. In the M/D/1 case this simply reduces to  $D_n = n a$ , for  $n \in \mathbb{N}_0$ , since for this system the Lyapunov exponent  $a$  is equal to the constant service time  $\sigma$ . So we know that  $D_n - D_m = (n - m) a$ , and thus, from formula (48), with the notation  $\rho = \lambda a$ , the expected waiting time  $W_{n+1}^{\{0\}}$  until service of the  $n + 1$ -th customer in the M/D/1 queue is given by

$$\begin{aligned} \mathbb{E}\left[W_{n+1}^{\{0\}}\right] &= \frac{1}{\lambda} \left\{ \sum_{m=1}^n e^{-\rho m} - n + \rho n + \sum_{m=2}^n e^{-\rho m} \sum_{j=1}^{m-1} \lambda^j \right. \\ &\quad \left. \left\{ p_j(na, (n-m+1)a, \dots, (n-m+j-1)a) \right. \right. \\ &\quad \left. \left. - p_j((n-m+1)a, \dots, (n-m+j)a) \right\} \right\} \\ &= \frac{1}{\lambda} \left\{ \sum_{m=1}^n e^{-\rho m} - n + \rho n + \sum_{m=2}^n e^{-\rho m} \sum_{j=1}^{m-1} \rho^j \right. \\ &\quad \left. \left\{ p_j(m, 1, \dots, j-1) - p_j(1, \dots, j) \right\} \right\}, \quad (49) \end{aligned}$$

where we used the translation-invariance property (28) of the polynomials  $p_k$  and the fact that a common factor of all arguments can be pulled out, see (29), to obtain the second equality. Theorem 7

gives an explicit formula for the polynomial difference  $p_j(m, 1, \dots, j-1) - p_j(1, \dots, j)$ , for all  $j \geq 1$ . Thus,

$$\begin{aligned} \mathbb{E} \left[ W_{n+1}^{\{0\}} \right] &= \frac{1}{\lambda} \left\{ \sum_{m=1}^n e^{-\rho m} - n + \rho n + \sum_{m=2}^n e^{-\rho m} \sum_{j=1}^{m-1} \rho^j \left\{ \frac{m^j}{j!} - \frac{m^{j-1}}{(j-1)!} \right\} \right\} \\ &= \frac{1}{\lambda} \left\{ -n(1-\rho) + \sum_{m=1}^n e^{-\rho m} \left\{ \sum_{j=0}^{m-1} \frac{(\rho m)^j}{j!} - \rho \sum_{j=0}^{m-2} \frac{(\rho m)^j}{j!} \right\} \right\}. \end{aligned}$$

Let us now investigate the summand given in the summation above a bit more closely.

$$\begin{aligned} e^{-\rho m} \left\{ \sum_{j=0}^{m-1} \frac{(\rho m)^j}{j!} - \rho \sum_{j=0}^{m-2} \frac{(\rho m)^j}{j!} \right\} \\ &= (1-\rho) - \left\{ 1 - e^{-\rho m} \sum_{j=0}^{m-1} \frac{(\rho m)^j}{j!} \right\} + \rho \left\{ 1 - e^{-\rho m} \sum_{j=0}^{m-2} \frac{(\rho m)^j}{j!} \right\} \\ &= (1-\rho) - e^{-\rho m} \sum_{j=m}^{\infty} \frac{(\rho m)^j}{j!} + e^{-\rho m} \sum_{j=m}^{\infty} \frac{j}{m} \frac{(\rho m)^j}{j!} \\ &= (1-\rho) + e^{-\rho m} \sum_{j=m+1}^{\infty} \frac{j-m}{m} \frac{(\rho m)^j}{j!}. \end{aligned}$$

Since we will need this result later on, we summarize these computations in a separate line.

$$e^{-\rho m} \left\{ \sum_{j=0}^{m-1} \frac{(\rho m)^j}{j!} - \rho \sum_{j=0}^{m-2} \frac{(\rho m)^j}{j!} \right\} = (1-\rho) + e^{-\rho m} \sum_{j=m+1}^{\infty} \frac{j-m}{m} \frac{(\rho m)^j}{j!}. \quad (50)$$

So we conclude that the (transient) waiting time of the  $n+1$ -th customer entering an M/D/1 queue is given by the expression

$$\mathbb{E} \left[ W_{n+1}^{\{0\}} \right] = \frac{1}{\lambda} \sum_{m=1}^n e^{-\rho m} \sum_{j=m+1}^{\infty} \frac{j-m}{m} \frac{(\rho m)^j}{j!}.$$

Taking the limit  $n \rightarrow \infty$  we obtain, for  $\rho < 1$ ,

$$\lim_{n \rightarrow \infty} \mathbb{E} \left[ W_{n+1}^{\{0\}} \right] = \frac{1}{\lambda} \sum_{m=1}^{\infty} e^{-\rho m} \sum_{j=m+1}^{\infty} \frac{j-m}{m} \frac{(\rho m)^j}{j!} = \frac{a\rho}{2(1-\rho)} = \mathbb{E} \left[ W^{\{0\}} \right], \quad (51)$$

the very last equality being due to the well-known Pollaczek-Khinchin formula from queueing theory, where  $W^{\{0\}}$  denotes the stationary waiting time until service in an M/D/1 single-server queue. A proof of the identity

$$\sum_{m=1}^{\infty} e^{-\rho m} \sum_{j=m+1}^{\infty} \frac{j-m}{m} \frac{(\rho m)^j}{j!} = \frac{\rho^2}{2(1-\rho)} \quad (52)$$



$$\begin{aligned}
& + \sum_{m=n-\xi+1}^n e^{-\lambda(\eta_\xi+(n-\xi)a-\eta_{n-m})} \sum_{j=1}^{m-1} \rho^j \left\{ p_j\left(m, \frac{\eta_{n-m+1} + (\xi - (n-m))a - \eta_\xi}{a}, \dots \right. \right. \\
& \qquad \qquad \qquad \left. \dots, \frac{\eta_{\xi-1} + (\xi - (n-m))a - \eta_\xi}{a}, \xi - (n-m), \dots, j-1 \right) \\
& \qquad \qquad \qquad \left. - p_j\left(\frac{\eta_{n-m+1} + (\xi - (n-m))a - \eta_\xi}{a}, \dots, \frac{\eta_{\xi-1} + (\xi - (n-m))a - \eta_\xi}{a}, \right. \right. \\
& \qquad \qquad \qquad \left. \left. \xi - (n-m), \dots, j \right) \right\},
\end{aligned}$$

where we used the translation-invariance of the polynomials  $p_k$  when shifting all arguments by  $-(\eta_\xi + (n-m-\xi)a)$ . Finally, we also extracted  $a^j$  from all polynomials  $p_j$ . In the expression above we find  $\mathbb{E} \left[ W_{n-\xi+1}^{\{0\}} \right]$  by collecting corresponding terms, compare (49). So we are left with

$$\begin{aligned}
& \mathbb{E} \left[ W_{n+1}^{\{\xi+1\}} \right] \\
& = \mathbb{E} \left[ W_{n-\xi+1}^{\{0\}} \right] + \frac{1}{\lambda} \left\{ \sum_{m=0}^{\xi-1} e^{-\lambda(\eta_\xi+(n-\xi)a-\eta_m)} - \xi + \lambda\eta_\xi \right. \\
& \qquad + \sum_{m=0}^{\xi-1} e^{-\lambda(\eta_\xi+(n-\xi)a-\eta_m)} \sum_{j=1}^{n-m-1} \rho^j \left\{ p_j\left(n-m, \frac{\eta_{m+1} + (\xi-m)a - \eta_\xi}{a}, \dots \right. \right. \\
& \qquad \qquad \qquad \left. \dots, \frac{\eta_{\xi-1} + (\xi-m)a - \eta_\xi}{a}, \xi-m, \dots, j-1 \right) \\
& \qquad \qquad \qquad \left. - p_j\left(\frac{\eta_{m+1} + (\xi-m)a - \eta_\xi}{a}, \dots, \frac{\eta_{\xi-1} + (\xi-m)a - \eta_\xi}{a}, \xi-m, \dots, j \right) \right\} \left. \right\},
\end{aligned}$$

where we reordered the summation by substituting the summation variable  $m$  by  $n-m$ . So we can apply Theorem 10 and obtain

$$\begin{aligned}
& \mathbb{E} \left[ W_{n+1}^{\{\xi+1\}} \right] \\
& = \mathbb{E} \left[ W_{n-\xi+1}^{\{0\}} \right] + \frac{1}{\lambda} \left\{ \sum_{m=0}^{\xi-1} e^{-\lambda(\eta_\xi+(n-\xi)a-\eta_m)} - \xi + \lambda\eta_\xi \right. \\
& \qquad + \sum_{m=0}^{\xi-1} e^{-\lambda(\eta_\xi+(n-\xi)a-\eta_m)} \sum_{j=1}^{n-m-1} \rho^j \left\{ h_j(n-m) \right. \\
& \qquad \qquad \left. - \sum_{l=1}^{\xi-1-m} \left\{ p_l\left(\frac{\eta_{m+1} + (\xi-m)a - \eta_\xi}{a}, \dots, \frac{\eta_{m+l} + (\xi-m)a - \eta_\xi}{a} \right) \right. \right. \\
& \qquad \qquad \left. \left. \right\} \right\} \left. \right\},
\end{aligned}$$

$$\begin{aligned}
& - p_l(l, \frac{\eta_{m+1} + (\xi - m)a - \eta_\xi}{a}, \dots, \frac{\eta_{m+l-1} + (\xi - m)a - \eta_\xi}{a}) \Big\} \\
& \left. h_{j-l}(n - m - l) \right\} \\
= & \mathbb{E} \left[ W_{n-\xi+1}^{\{0\}} \right] + \frac{1}{\lambda} \left\{ \sum_{m=0}^{\xi-1} e^{-\lambda(\eta_\xi + (n-\xi)a - \eta_m)} - \xi + \lambda \eta_\xi \right. \\
& + \sum_{m=0}^{\xi-1} e^{-\lambda(\eta_\xi + (n-\xi)a - \eta_m)} \left\{ \sum_{j=1}^{n-m-1} \rho^j h_j(n - m) \right. \\
& + \sum_{l=1}^{\xi-1-m} \left\{ p_l(\lambda(\eta_m + (m+l-\xi)a), \lambda \eta_{m+1}, \dots, \lambda \eta_{m+l-1}) \right. \\
& \left. \left. \left. - p_l(\lambda \eta_{m+1}, \dots, \lambda \eta_{m+l}) \right) \right\} \right. \\
& \left. \left. \left. \sum_{j=1}^{n-m-1} \rho^{j-l} h_{j-l}(n - m - l) \right\} \right\} \\
= & \mathbb{E} \left[ W_{n-\xi+1}^{\{0\}} \right] + \frac{1}{\lambda} \left\{ \sum_{m=0}^{\xi-1} e^{-\lambda(\eta_\xi + (n-\xi)a - \eta_m)} - \xi + \lambda \eta_\xi \right. \\
& + \sum_{m=0}^{\xi-1} e^{-\lambda(\eta_\xi + (n-\xi)a - \eta_m)} \left\{ \sum_{j=1}^{n-m-1} \left\{ \frac{(\rho(n-m))^j}{j!} - \rho \frac{(\rho(n-m))^{j-1}}{(j-1)!} \right\} \right. \\
& + \sum_{l=1}^{\xi-1-m} \left\{ p_l(\lambda(\eta_m + (m+l-\xi)a), \lambda \eta_{m+1}, \dots, \lambda \eta_{m+l-1}) \right. \\
& \left. \left. \left. - p_l(\lambda \eta_{m+1}, \dots, \lambda \eta_{m+l}) \right) \right\} \right. \\
& \left. \left. \left. \left\{ \sum_{j=l}^{n-m-1} \frac{(\rho(n-m-l))^{j-l}}{(j-l)!} - \rho \sum_{j=l+1}^{n-m-1} \frac{(\rho(n-m-l))^{j-l-1}}{(j-l-1)!} \right\} \right\} \right\} \\
= & \mathbb{E} \left[ W_{n-\xi+1}^{\{0\}} \right] + \eta_\xi - \frac{\xi}{\lambda} + \frac{1}{\lambda} \left\{ \sum_{m=0}^{\xi-1} e^{-\lambda(\eta_\xi + (m-\xi)a - \eta_m)} \right. \\
& \left. e^{-\rho(n-m)} \left\{ \sum_{j=0}^{n-m-1} \frac{(\rho(n-m))^j}{j!} - \rho \sum_{j=0}^{n-m-2} \frac{(\rho(n-m))^j}{j!} \right\} \right. \\
& + \sum_{m=0}^{\xi-2} e^{-\lambda(\eta_\xi + (m-\xi)a - \eta_m)} \sum_{l=1}^{\xi-1-m} \left\{ p_l(\lambda(\eta_m + (m+l-\xi)a), \lambda \eta_{m+1}, \dots, \lambda \eta_{m+l-1}) \right.
\end{aligned}$$

$$e^{-\rho(n-m-l)} \left\{ \sum_{j=0}^{n-m-l-1} \frac{(\rho(n-m-l))^j}{j!} - \rho \sum_{j=0}^{n-m-l-2} \frac{(\rho(n-m-l))^j}{j!} \right\} e^{-\rho l} - p_l(\lambda\eta_{m+1}, \dots, \lambda\eta_{m+l})$$

But in this formula we realize expressions which we have already investigated in the previous section, namely in (50). Thus, when using the abbreviation  $\Theta_m$  which we introduced in (53), we see that

$$\begin{aligned} & \mathbb{E} \left[ W_{n+1}^{\{\xi+1\}} \right] \\ &= \mathbb{E} \left[ W_{n-\xi+1}^{\{0\}} \right] + \eta_\xi - \frac{\xi}{\lambda} + \frac{1}{\lambda} \left\{ \sum_{m=0}^{\xi-1} e^{-\lambda(\eta_\xi + (m-\xi)a - \eta_m)} \left\{ (1-\rho) + \Theta_{n-m} \right\} \right. \\ & \quad + \sum_{m=0}^{\xi-2} e^{-\lambda(\eta_\xi + (m-\xi)a - \eta_m)} \sum_{l=1}^{\xi-1-m} \left\{ p_l(\lambda(\eta_m + (m+l-\xi)a), \lambda\eta_{m+1}, \dots, \lambda\eta_{m+l-1}) \right. \\ & \quad \quad \quad \left. \left. - p_l(\lambda\eta_{m+1}, \dots, \lambda\eta_{m+l}) \right\} e^{-\rho l} \left\{ (1-\rho) + \Theta_{n-m-l} \right\} \right\} \\ &= \mathbb{E} \left[ W_{n-\xi+1}^{\{0\}} \right] + \eta_\xi - \frac{\xi}{\lambda} + \frac{(1-\rho)}{\lambda} \left\{ \sum_{m=0}^{\xi-1} e^{-\lambda(\eta_\xi + (m-\xi)a - \eta_m)} \right. \\ & \quad + \sum_{m=0}^{\xi-2} e^{-\lambda(\eta_\xi + (m-\xi)a - \eta_m)} \sum_{l=1}^{\xi-1-m} \left\{ p_l(\lambda(\eta_m + (m+l-\xi)a), \lambda\eta_{m+1}, \dots, \lambda\eta_{m+l-1}) \right. \\ & \quad \quad \quad \left. \left. - p_l(\lambda\eta_{m+1}, \dots, \lambda\eta_{m+l}) \right\} e^{-\rho l} \right\} \\ & \quad + \frac{1}{\lambda} \left\{ \sum_{m=0}^{\xi-1} e^{-\lambda(\eta_\xi + (m-\xi)a - \eta_m)} \Theta_{n-m} + \sum_{m=0}^{\xi-2} e^{-\lambda(\eta_\xi + (m-\xi)a - \eta_m)} \right. \\ & \quad \quad \quad \sum_{l=1}^{\xi-1-m} \left\{ p_l(\lambda(\eta_m + (m+l-\xi)a), \lambda\eta_{m+1}, \dots, \lambda\eta_{m+l-1}) \right. \\ & \quad \quad \quad \left. \left. - p_l(\lambda\eta_{m+1}, \dots, \lambda\eta_{m+l}) \right\} e^{-\rho l} \Theta_{n-m-l} \right\}. \end{aligned}$$

As a final step we can rewrite

$$\mathbb{E} \left[ W_{n-\xi+1}^{\{0\}} \right] = \mathbb{E} \left[ W^{\{0\}} \right] - \left( \mathbb{E} \left[ W^{\{0\}} \right] - \mathbb{E} \left[ W_{n-\xi+1}^{\{0\}} \right] \right) = \frac{a\rho}{2(1-\rho)} - \frac{1}{\lambda} \sum_{m=n-\xi+1}^{\infty} \Theta_m,$$



and get for the expectation of the (transient) waiting time of the  $n + 1$ -th customer in a network of the assumed structure

$$\begin{aligned}
\mathbb{E} \left[ W_{n+1}^{\{\xi+1\}} \right] & \tag{54} \\
= & \frac{a\rho}{2(1-\rho)} + \eta_\xi - \frac{\xi}{\lambda} + \frac{(1-\rho)}{\lambda} \left\{ \sum_{m=0}^{\xi-1} e^{-\lambda(\eta_\xi + (m-\xi)a - \eta_m)} \right. \\
& + \sum_{m=0}^{\xi-2} e^{-\lambda(\eta_\xi + (m-\xi)a - \eta_m)} \sum_{l=1}^{\xi-1-m} \left\{ p_l(\lambda(\eta_m + (m+l-\xi)a), \lambda\eta_{m+1}, \dots, \lambda\eta_{m+l-1}) \right. \\
& \qquad \qquad \qquad \left. \left. - p_l(\lambda\eta_{m+1}, \dots, \lambda\eta_{m+l}) \right\} e^{-\rho l} \right\} \\
& - \frac{1}{\lambda} \left\{ \sum_{m=n-\xi+1}^{\infty} \Theta_m - \sum_{m=0}^{\xi-1} e^{-\lambda(\eta_\xi + (m-\xi)a - \eta_m)} \Theta_{n-m} - \sum_{m=0}^{\xi-2} e^{-\lambda(\eta_\xi + (m-\xi)a - \eta_m)} \right. \\
& \qquad \qquad \qquad \sum_{l=1}^{\xi-1-m} \left\{ p_l(\lambda(\eta_m + (m+l-\xi)a), \lambda\eta_{m+1}, \dots, \lambda\eta_{m+l-1}) \right. \\
& \qquad \qquad \qquad \left. \left. - p_l(\lambda\eta_{m+1}, \dots, \lambda\eta_{m+l}) \right\} e^{-\rho l} \Theta_{n-m-l} \right\}
\end{aligned}$$

>From (53) we know that  $\Theta_m$  goes to zero as  $m \rightarrow \infty$  and thus we see that the expectation of  $W_{n+1}^{\{\xi+1\}}$  converges to a finite limit, namely to the limit stated in Theorem 5. On the other hand, by the way  $W_n$  has been defined in (4) we also know that this convergence is monotone in  $n$ . So we can interchange limit and integration by Lévy's theorem on monotone convergence and conclude

$$\lim_{n \rightarrow \infty} \mathbb{E} \left[ W_{n+1}^{\{\xi+1\}} \right] = \mathbb{E} \left[ \lim_{n \rightarrow \infty} W_{n+1}^{\{\xi+1\}} \right] = \mathbb{E} \left[ W^{\{\xi+1\}} \right],$$

which proves the theorem.  $\square$

**Remark** In the above proof we have actually done more than just proved the explicit representation of the expectation for the stationary waiting times. With (54) we have also given an explicit representation of the transient waiting times using only polynomials up to order  $\xi - 1$ . Whenever  $n \gg \xi$  this will clearly result in a significant reduction of computational efforts necessary to obtain the exact solution of transient waiting times.

**Remark** In [3] another property of the polynomials  $p_k$  is mentioned:  $p_k(0, 1, \dots, k-1) = \frac{1}{2}$  for all  $k \geq 2$ . If we apply this property to the M/D/1 case, where  $D_n = na$  for all  $n \geq 0$ , we learn that

$$\sum_{k=0}^{\infty} \lambda^k p_{k+1}(D_0, \dots, D_k) = a \sum_{k=1}^{\infty} \rho^k p_{k+1}(0, 1, \dots, k) = \frac{a\rho}{2(1-\rho)} = \mathbb{E}[W^{\{0\}}],$$

for each arrival intensity  $\lambda \in [0, a^{-1})$ . So this observation suggests that

$$\mathbb{E}[W^{\{\xi+1\}}] = \sum_{k=0}^{\infty} \lambda^k p_{k+1}(D_0, \dots, D_k) \quad (55)$$

for all finite  $\xi \geq 0$ , i.e. that the expected stationary waiting time  $\mathbb{E}[W^{\{\xi+1\}}]$  can be expanded in an infinite power-series with respect to the arrival intensity  $\lambda$ , where the coefficients of this expansion are given by  $p_{k+1}(D_0, \dots, D_k)$ . This conjecture is actually true. All the tools that are required to prove this statement are given in this paper. But since the proof is similar to the one of Theorem 5, perhaps even more technical, we will not outline it here.

## Appendix

Before we give the proof of identity (52) we state some preliminary results:

**Lemma 2** For all  $k \geq 1$  the following equality holds:

$$\sum_{j=0}^k \binom{k}{j} (-1)^{k-j} j^l = \begin{cases} 0 & \text{for } l = 0, \dots, k-1, \\ k! & \text{for } l = k. \end{cases} \quad (56)$$

**Proof** by induction with respect to  $k$ . For  $l = 0$  the left-hand side of (56) breaks down to a simple binomial series which simplifies to  $(1 + (-1))^k = 0$ . Let  $l \geq 1$ . It is immediate to see that (56) holds for  $k = 1$ . Let us assume the validity of (56) for some  $k \geq 1$ . Then

$$\begin{aligned} \sum_{j=0}^{k+1} \binom{k+1}{j} (-1)^{k+1-j} j^l &= \sum_{j=1}^{k+1} \frac{(k+1)!}{(k+1-j)! j!} (-1)^{k+1-j} j^l \\ &= (k+1) \sum_{j=1}^{k+1} \binom{k}{j-1} (-1)^{k+1-j} j^{l-1} = (k+1) \sum_{j=0}^k \binom{k}{j} (-1)^{k-j} (j+1)^{l-1} \\ &= (k+1) \sum_{j=0}^k \binom{k}{j} (-1)^{k-j} \sum_{i=0}^{l-1} \binom{l-1}{i} j^i = (k+1) \sum_{i=0}^{l-1} \binom{l-1}{i} \sum_{j=0}^k \binom{k}{j} (-1)^{k-j} j^i \\ &= \begin{cases} 0 & \text{for } l = 0, \dots, k, \\ (k+1)! & \text{for } l = k+1, \end{cases} \end{aligned}$$

where the last equality follows from the induction hypothesis, since we assumed that the inner summation is equal to zero, whenever  $i = 0, 1, \dots, k-1$ , and equal to  $k!$  if  $i = k$ , which only happens if  $l = k+1$ .  $\square$

**Lemma 3** For each  $k \geq 0$ ,

$$\sum_{m=0}^k \binom{k}{m} (-1)^{k-m} (m+1)^{k+1} = \frac{1}{2} (k+2)! . \quad (57)$$

**Proof** by induction with respect to  $k$ . Note that

$$\begin{aligned} \sum_{m=0}^k \binom{k}{m} (-1)^{k-m} (m+1)^{k+1} &= \sum_{m=0}^k \binom{k}{m} (-1)^{k-m} \sum_{j=0}^{k+1} \binom{k+1}{j} m^j \\ &= \sum_{j=0}^{k+1} \binom{k+1}{j} \sum_{m=0}^k \binom{k}{m} (-1)^{k-m} m^j . \end{aligned}$$

Using Lemma 2 yields

$$\begin{aligned} \sum_{m=0}^k \binom{k}{m} (-1)^{k-m} (m+1)^{k+1} &= \binom{k+1}{k} k! + \sum_{m=0}^k \binom{k}{m} (-1)^{k-m} m^{k+1} \\ &= (k+1)! + \sum_{m=1}^k \binom{k}{m} (-1)^{k-m} m^{k+1} = (k+1)! + k \sum_{m=1}^k \binom{k-1}{m-1} (-1)^{k-1-(m-1)} m^k \\ &= (k+1)! + k \sum_{m=0}^{k-1} \binom{k-1}{m} (-1)^{k-1-m} (m+1)^k . \end{aligned}$$

Assume now that (57) holds for some  $k-1$ . Then,

$$\sum_{m=0}^k \binom{k}{m} (-1)^{k-m} (m+1)^{k+1} = (k+1)! + \frac{k}{2} (k+1)! = \frac{1}{2} (k+2)!$$

and thus, (57) holds for all  $k \geq 0$ .  $\square$

**Lemma 4** For all  $0 \leq \rho < 1$ , the following identity holds:

$$\sum_{m=1}^{\infty} e^{-\rho m} \sum_{j=m+1}^{\infty} \frac{j-m}{m} \frac{(\rho m)^j}{j!} = \frac{\rho^2}{2(1-\rho)} \quad (58)$$

**Proof** Let  $\rho \in [0, 1)$  and define

$$g(\rho) = \sum_{m=1}^{\infty} e^{-\rho m} \sum_{j=m+1}^{\infty} \frac{j-m}{m} \frac{(\rho m)^j}{j!}.$$

Since we have  $\frac{\rho^2}{2(1-\rho)} = \frac{1}{2} \sum_{k=0}^{\infty} \rho^{k+2}$ , for  $\rho \in [0, 1)$ , (58) is proved if we show that  $g(\rho)$  can be represented in the form  $g(\rho) = \frac{1}{2}(\rho^2 + \rho^3 + \dots)$  for each  $\rho \in [0, 1)$ . Thus, it suffices to show that

$$\left. \frac{d^k}{d\rho^k} g(\rho) \right|_{\rho=0} = \begin{cases} 0, & \text{for } k = 0, 1, \\ \frac{1}{2} k!, & \text{for } k \geq 2. \end{cases} \quad (59)$$

For  $k = 0$ , i.e.  $g(0) = 0$ , there is nothing to show. The first two derivatives of  $g(\rho)$  are given by

$$\frac{d}{d\rho} g(\rho) = \sum_{m=1}^{\infty} e^{-\rho m} \sum_{j=m}^{\infty} \frac{(\rho m)^j}{j!} \quad \text{and} \quad \frac{d^2}{d\rho^2} g(\rho) = \sum_{m=1}^{\infty} m e^{-\rho m} \frac{(\rho m)^{m-1}}{(m-1)!}. \quad (60)$$

Thus,  $\left. \frac{d}{d\rho} g(\rho) \right|_{\rho=0} = 0$  also holds. Furthermore, (60) gives

$$\frac{d^{k+2}}{d\rho^{k+2}} g(\rho) = \sum_{m=1}^{\infty} m \sum_{j=0}^k \binom{k}{j} \frac{d^{k-j}}{dx^{k-j}} e^{-\rho m} \frac{d^j}{d\rho^j} \frac{(\rho m)^{m-1}}{(m-1)!}$$

for  $k \geq 0$  and, in particular,

$$\begin{aligned} \left. \frac{d^{k+2}}{d\rho^{k+2}} g(\rho) \right|_{\rho=0} &= \sum_{m=1}^{k+1} m \binom{k}{m-1} (-m)^{k-m+1} m^{m-1} = \sum_{m=0}^k \binom{k}{m} (-1)^{k-m} (m+1)^{k+1} \\ &= \frac{1}{2} (k+2)! \end{aligned}$$

from Lemma 3 which completes the proof of (58).  $\square$

## References

- [1] Baccelli, F., G. Cohen, G.J. Olsder and J.P. Quadrat (1992) *Synchronisation and Linearity*. J. Wiley & Sons, Chichester.
- [2] Baccelli, F., S. Hasenfuss and V. Schmidt (1996) Expansions for steady-state characteristics in (max, +)-linear systems. Preprint. INRIA Sophia-Antipolis / University of Ulm.
- [3] Baccelli, F. and V. Schmidt (1996) Taylor series expansions for Poisson driven (max, +)-linear systems. *Ann. Appl. Probab.* **6**, 138-185.

- [4] Gong, W.B. and J.Q. Hu (1992) The MacLaurin series for the GI/G/1 queue. *J. Appl. Prob.* **29**, 176-184.
- [5] Hu, J.Q. (1995) Analyticity of single-server queues in light traffic. *QUESTA* **19**, 63-80.
- [6] Hu, J.Q., Nananuku, S. and W.B. Gong (1994) A New Approach to (s,S) Inventory Problems. *J. Appl. Prob.* **30**, 898-912.
- [7] Jean-Marie, A. (1996) The waiting time distribution in Poisson-driven deterministic systems. Preprint. INRIA Sophia-Antipolis.
- [8] Reiman, M.I. and B. Simon (1988) An interpolation approximation for queueing systems with Poisson input. *Oper. Res.* **36**, 454-469.
- [9] Reiman, M.I. and B. Simon (1989) Open queueing systems in light traffic. *Math. Oper. Res.* **14**, 26-59.
- [10] Titchmarsh, E.C. (1939) The theory of functions. *Oxford University Press*.
- [11] Zazanis, M.A. (1992) Analyticity of Poisson-driven stochastic systems. *Adv. Appl. Probab.* **24**, 532-541.



---

Unité de recherche INRIA Lorraine, Technopôle de Nancy-Brabois, Campus scientifique,  
615 rue du Jardin Botanique, BP 101, 54600 VILLERS LÈS NANCY  
Unité de recherche INRIA Rennes, Irisa, Campus universitaire de Beaulieu, 35042 RENNES Cedex  
Unité de recherche INRIA Rhône-Alpes, 655, avenue de l'Europe, 38330 MONTBONNOT ST MARTIN  
Unité de recherche INRIA Rocquencourt, Domaine de Voluceau, Rocquencourt, BP 105, 78153 LE CHESNAY Cedex  
Unité de recherche INRIA Sophia-Antipolis, 2004 route des Lucioles, BP 93, 06902 SOPHIA-ANTIPOLIS Cedex

---

Éditeur  
INRIA, Domaine de Voluceau, Rocquencourt, BP 105, 78153 LE CHESNAY Cedex (France)  
ISSN 0249-6399