



HAL
open science

On the role of machine learning in satellite internet of things: A survey of techniques, challenges, and future directions

Alexander Y Choquenaira-Florez, Juan A Fraire, Hannah B Pasandi, Hervé Rivano

► To cite this version:

Alexander Y Choquenaira-Florez, Juan A Fraire, Hannah B Pasandi, Hervé Rivano. On the role of machine learning in satellite internet of things: A survey of techniques, challenges, and future directions. *Computer Networks*, 2025, 10.1016/j.comnet.2025.111063. hal-04911360

HAL Id: hal-04911360

<https://inria.hal.science/hal-04911360v1>

Submitted on 24 Jan 2025

HAL is a multi-disciplinary open access archive for the deposit and dissemination of scientific research documents, whether they are published or not. The documents may come from teaching and research institutions in France or abroad, or from public or private research centers.

L'archive ouverte pluridisciplinaire **HAL**, est destinée au dépôt et à la diffusion de documents scientifiques de niveau recherche, publiés ou non, émanant des établissements d'enseignement et de recherche français ou étrangers, des laboratoires publics ou privés.



Distributed under a Creative Commons Attribution 4.0 International License

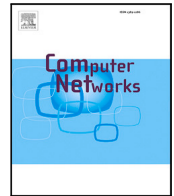

On the role of machine learning in satellite internet of things: A survey of techniques, challenges, and future directions

Alexander Y. Choquenaira-Florez^a, Juan A. Fraire^{a,b,*}, Hannah B. Pasandi^{a,c}, Hervé Rivano^a

^a Inria, INSA Lyon, CITI, UR3720, 69621 Villeurbanne, France

^b CONICET - Universidad Nacional de Córdoba, Córdoba, Argentina

^c University of California - Berkeley, Berkeley, CA, USA

ARTICLE INFO

Keywords:

Satellite IoT
Satellite networks
Machine learning

ABSTRACT

The drive towards an interconnected world via satellites is reshaping the landscape of communication technologies. This survey comprehensively reviews studies in the Satellite Internet of Things (SIoT) domain, focusing on the role of Machine Learning (ML) techniques. Indeed, the global data collection scale in SIoT is ideally suited for data-intensive and sophisticated ML approaches. We highlight the innovative use of ML to address specific SIoT challenges, aiming to identify current trends, methodologies, and outcomes. We considered theoretical, practical, and experimental research, organizing existing publications into a new taxonomy that intersects ML and SIoT categories. Our taxonomy reveals that Deep Learning (DL), Reinforcement Learning (RL), and Federated Learning (FL) are widely applied to address radio access schemes, resource and network management, and application-specific issues. This survey identifies critical gaps in current research on ML applications in SIoT, such as the lack of differentiation between space-based and ground-based processing, insufficient integration of SIoT-specific metrics, and the oversight of limited computational resources on orbiting satellites. These issues raise concerns about the feasibility and efficiency of proposed solutions. We propose promising research directions based on the derived insights to effectively bridge the gap between ML researchers and industrial SIoT entities.

1. Introduction

Satellite IoT (SIoT) unlocks the potential of an unprecedented global-scale data collection and delivery system. The increasing number of space projects [1], including innovations such as cost-effective launches and affordable nano-satellites known as *CubeSats*, has significantly boosted the popularity of satellite communications. This increase has drawn the attention of researchers and industries in the Internet of Things (IoT) field, eager to explore the potential for providing global network coverage to enable continuous and reliable communication. SIoT emerges as the combination of satellite communications with IoT, enabled by the current advancement in communication technologies, which enable the connection between satellites and IoT devices [2]. SIoT uniquely fits the emerging nano-satellite industry, as *CubeSats* can efficiently handle low-data rate, small-volume, and long-range communications.

Integrating Satellite Networks with IoT addresses the inherent limitations of traditional IoT systems and expands the potential of IoT applications. Besides overcoming these limitations, integrating these fields provides an unparalleled opportunity to control, monitor, collect,

analyze, and process large amounts of data, which is significant since IoT devices are continuously increasing [3]. We summarize the main limitations of terrestrial IoT and possible satellite solutions.

- **Coverage Limitations:** Traditional IoT systems primarily rely on terrestrial networks such as cellular, Wi-Fi, or LPWAN, which are limited by geographic coverage. These limitations hinder the deployment and effectiveness of IoT applications in remote, rural, or hard-to-reach areas, including oceans, deserts, and isolated regions.

Satellite Solution: Satellite networks provide comprehensive global coverage, filling in the gaps where terrestrial networks are unavailable or unreliable. This integration enables IoT devices to operate seamlessly across vast and diverse geographical areas, ensuring uninterrupted connectivity.

- **Enhancing Reliability and Resilience:** Terrestrial networks are susceptible to failures due to natural disasters, infrastructure damage, or network congestion, leading to potential disruptions in IoT services.

* Corresponding author at: Inria, INSA Lyon, CITI, UR3720, 69621 Villeurbanne, France.

E-mail addresses: alexander.choquenaira-florez@inria.fr (A.Y. Choquenaira-Florez), juan.fraire@inria.fr (J.A. Fraire), hannaneh.barahouei-pasandi@inria.fr (H.B. Pasandi), herve.rivano@inria.fr (H. Rivano).

<https://doi.org/10.1016/j.comnet.2025.111063>

Received 5 July 2024; Received in revised form 6 September 2024; Accepted 13 January 2025

Available online 22 January 2025

1389-1286/© 2025 Elsevier B.V. All rights are reserved, including those for text and data mining, AI training, and similar technologies.

Satellite Solution: By incorporating satellite networks, IoT systems gain an additional layer of connectivity independent of terrestrial infrastructure, enhancing the overall reliability and resilience of the network. This is particularly crucial for mission-critical applications where consistent connectivity is essential.

- **Facilitating Large-Scale Data Management:** The rapid proliferation of IoT devices generates massive amounts of data that need to be transmitted, processed, and analyzed efficiently. Terrestrial networks may often struggle with bandwidth and latency requirements, especially in remote areas.

Satellite Solution: Satellite networks can handle the high volume of data generated by IoT devices, offering scalable bandwidth and the ability to transmit data over long distances with minimal delay. This capability is vital for real-time data collection, monitoring, and analysis, supporting applications ranging from environmental monitoring to global logistics.

- **Expanding IoT Applications:** The limited reach of terrestrial networks restricts the scope of IoT applications, particularly those requiring widespread geographical coverage or operating in isolated environments.

Satellite Solution: Integrating satellite networks opens up new possibilities for IoT applications, including remote asset tracking, global environmental monitoring, and large-scale agricultural management. It enables IoT to become truly ubiquitous, supporting innovative use cases that were previously unfeasible.

Machine Learning (ML), powered by big data, is, at the same time, growing its relevance in the context of SIoT because it can extract meaningful insights and patterns from massive datasets, enabling continuous and reliable communication across global networks. Moreover, the evolution of neural networks (NN) has paved the way for *deep learning*, a more sophisticated data analysis, enhancing the capability to manage and interpret the immense volume of data generated by satellite communications and IoT devices in space. Multi-layer Perceptron (MLP) and specialized derivatives can effectively handle and exploit satellite data. While we dive deep into them later in the paper, we introduce these basic concepts.

- **Multi-layer Perceptron (MLP).** MLP is a foundational model consisting of input, hidden, and output layers. MLPs utilize back-propagation, a training algorithm that adjusts weights using gradient descent methods to minimize a predefined loss function [4]. MLPs are at the core of the current ML revolution.
- **Other Specialized Neural Networks.** With the continuous increase of computational power, specialized neural networks have been developed to address the limitations of traditional NNs, especially in processing diverse data types such as images and text. These specialized NNs, such as Convolutional NN (CNNs), Recurrent NNs (RNNs), Long Short-Term Memory Networks (LSTMs), and Deep Reinforcement Learning (DRL), among others, introduce additional features that boost the potential of the original NN models. They are instrumental in handling the vast and complex datasets characteristic of Space IoT, enhancing the capability to manage and interpret the immense volume of data generated by satellite communications and IoT devices in space.

The intersection of SIoT and ML. These advancements in ML are a perfect fit for unlocking efficient and effective operations within the expanding context of SIoT [5]. The evolution of NN into these many specialized types has paved the way for more sophisticated data analysis, ensuring efficient and effective operations within the expanding context of SIoT. The increasing amount of data generated from SIoT space systems necessitates advanced techniques for practical analysis and utilization. Besides application data, telemetry streams are data feeds that unlock new ML techniques for autonomous satellite constellation operations [6]. The integration of ML is essential to address the

increasing complexity and limitations of traditional methods in managing SIoT networks. These advancements underscore the importance of ML in ensuring efficient and effective operations within the expanding context of Space IoT [5,7]. We summarize them as follows:

- **Managing Environmental Dynamics in Satellite Communications:** Traditional methods struggle to effectively handle satellite communications' unpredictable nature, such as fluctuating channel conditions, signal interference, and environmental changes. In contrast, ML techniques enable SIoT systems to manage these dynamic factors by continuously learning from environmental data, resulting in more efficient resource allocation and enhanced communication reliability.
- **Enhancing Resource Allocation and Network Traffic Forecasting:** The complexity of SIoT networks often leads to inefficient resource allocation and inaccurate network traffic forecasting, challenges that traditional methods need to address effectively. ML algorithms, however, can optimize these processes by analyzing large datasets in real-time, thereby improving both resource allocation and the accuracy of traffic predictions, leading to better network performance and utilization.
- **Strengthening Security and Reducing Vulnerabilities:** Traditional methods may leave SIoT networks vulnerable to security threats because they cannot quickly adapt to evolving risks. In contrast, ML can enhance security by detecting anomalies, predicting potential threats, and automating responses, thereby reducing vulnerabilities and increasing the robustness of SIoT networks.
- **Automating Decision-Making and Extracting Insights from Big Data:** Traditional methods find it challenging to efficiently process the vast amount of data generated by satellite platforms and SIoT devices. ML addresses this challenge by excelling at processing large data volumes, extracting meaningful insights, and automating decision-making processes, enabling SIoT systems to operate more independently and effectively in complex environments.
- **Optimizing Synchronization and Reducing Signaling Overhead:** While satellite constellations may seem like deterministic infrastructures, the reality is that IoT devices often rely on lower-end electronics, particularly unreliable clocks, making precise synchronization with satellite coverage windows a challenge. Traditional methods that rely heavily on signaling protocols to manage synchronization can result in significant resource consumption, reducing overall system efficiency. ML techniques can offer a solution by learning patterns from previous interactions and optimizing synchronization processes.

These advancements underscore the importance of ML in ensuring efficient and effective operations within the expanding context of Space IoT [5,7].

Application scope. Industries such as agriculture, smart cities, traffic management, and energy systems stand to benefit immensely from the intelligent solutions derived from ML applications in SIoT. Specifically, SIoT could create a large network environment that grants a massive data collection to enable future applications such as self-driving cars, automated healthcare, environment monitoring, disaster management, supply chain management, remote healthcare, global tracking, and deploying urban solutions in less accessible regions, among others [8]. Besides opportunities, SIoT also brings several technical challenges related to the long space-terrestrial channel, satellite orbital dynamics, and IoT device constraints. These domain applications use the full potential of SIoT and ML to enhance and provide innovative solutions.

Table 1
Comparison of SIoT-related surveys and their characteristics.

Survey	[9]	[10]	[11]	[12]	[5,13]	[14,15]	[16]	[17,18]	[19]	Our survey
Reviews satellite network	×	×	×	×	✓	×	×	×	✓	✓
Reviews security issues	✓	×	×	×	×	×	✓	×	×	✓
Reviews ML applications	✓	✓	×	×	✓	×	×	×	×	✓
Reviews IoT	✓	✓	×	×	×	✓	✓	×	✓	✓
Reviews satellite IoT	×	×	✓	✓	×	×	×	×	✓	✓
Reviews LPWAN technologies	×	×	×	×	×	×	×	✓	×	✓
Provides a general overview	✓	✓	✓	✓	✓	✓	✓	✓	×	✓

Related surveys. Several survey papers have already proven the relevance of ML and satellite networks. These papers address various issues such as security, intelligent traffic management, agriculture, and smart cities, highlighting the diverse applications of ML in enhancing IoT systems, such as [9,10]. Some survey papers detail the solutions, limitations, challenges, and development trends in deploying SIoT applications [11,12]. In contrast, others focus specifically on the role of ML in general satellite communications, emphasizing areas like traffic forecasting, energy management, and anomaly detection [5,13].

Due to its nature, SIoT addresses unique challenges and research opportunities that introduce problems such as latency, resource optimization, channel allocation, and security transmissions in IoT data traffic characterized by *low data rate*, *low data volume*, and *latency tolerance*. While surveys provide comprehensive reviews of various aspects of IoT, which are critical to understanding the application of ML in Slot. [14] details a thorough review of technologies and applications in IoT and presents forthcoming challenges for research in the field. Another work [15] focuses on the application of IoT in cloud and fog computing. Finally, [16] provides a structured analysis of IoT security challenges and opportunities, focusing on the IoT protocols stack across application domains. Additionally, other surveys review the application of LPWAN technologies in the IoT field. For instance, [17,18] present descriptive and comparative evaluations of different types of LPWAN technology (e.g., NB-IoT, LoRa, Sigfox) is performed, focusing on their pros, cons, and applications. The authors indicate that LoRa is profitable in terms of battery life and cost, while NB-IoT is a better alternative in terms of latency and quality of services. More specifically, [18] analyzes developing countries' perspectives. Despite the existing surveys on the application of ML in IoT, most of them focus on terrestrial IoT, overlooking the challenges and critical aspects related to the space domain, such as the differences between on-board and on-ground processing, long communication delays, and resource-constrained environments. These factors distinguish this domain from another and demand specialized and sophisticated ML solutions. This is the first survey to specifically explore ML techniques' integration and application within the SIoT domain's unique context. This survey fills a critical gap in the literature by addressing the specific challenges and constraints of ML in SIoT, which can lead to developing new and efficient applications in the SIoT domain.

Given the rapid advancements and growing interest in the SIoT field, a comprehensive survey is essential to analyze and synthesize current research, identify emerging trends, and highlight new opportunities. The Table 1 presents a detailed comparison of related surveys against our work

Survey highlights. This survey uncovers several critical gaps in the current research on ML applications in SIoT. Firstly, many studies overlook the practical execution of training and inference, often failing to distinguish between space-based and ground-based processing. Additionally, a notable lack of integration between ML techniques and SIoT-specific metrics impedes the evaluation of real-world applicability and performance. Furthermore, most existing papers disregard the limited computational resources available on orbiting satellites, an oversight that raises concerns about the feasibility and efficiency of proposed solutions in operational environments.

The main contributions of this paper are summarized as follows:

- *Identification of Research Gaps:* We systematically identify gaps, opportunities, and challenges in the current research on ML applications in SIoT. This provides valuable insights for guiding future research and uncovering opportunities for further exploration.
- *Comprehensive Overview of ML Advancements:* This survey offers an extensive overview of the latest advancements in ML applications within the SIoT domain, helping researchers understand the current landscape better and develop more efficient and intelligent SIoT applications.
- *Roadmap for Future Research:* We present a potential roadmap for future research directions, encouraging the development of innovative studies and applications. This roadmap aims to stimulate growth and foster innovation within the SIoT field.
- *Resource for Researchers and Practitioners:* Designed as an indispensable resource, this survey is a critical reference for researchers and developers working on intelligent applications in the SIoT domain. It is intended to support the continued advancement and expansion of the field.

These contributions underscore the importance and value of this survey in advancing the understanding and application of ML in SIoT. The paper critically analyzes existing research and offers a forward-looking perspective on the field's future direction.

Survey design and goal. This survey is designed to be an indispensable resource for current and future researchers interacting with public and private SIoT companies or agencies. It offers a comprehensive overview of the latest advancements in ML applications within the SIoT domain. It meticulously examines these developments to guide the creation of more efficient and intelligent SIoT applications, thereby driving steady growth and innovation in the field. Furthermore, this survey identifies emerging trends and opportunities, providing a roadmap for future research directions. It encourages the development of cutting-edge technologies and applications by highlighting gaps in current research and proposing potential areas for exploration. It is an essential read for anyone involved in the intersection of satellite technology, IoT, and machine learning, providing a solid foundation for the next generation of intelligent applications in this rapidly advancing field. A graphical chart that illustrates the coverage of the reviewed papers can be seen in Fig. 1.

Organization. The rest of this paper is organized as follows: In Section 2, we briefly present Satellite IoT, detailing traditional technologies, characteristics, emerging applications, and relevance in the future of communications. Section 3 provides a comprehensive and general overview of ML techniques, detailing traditional and state-of-the-art methods. The techniques discussed are those explored by the papers reviewed in this survey. Section 4 explores the intersection of SIoT and ML by framing them in our proposed taxonomy. This section identifies the open challenges and problems addressed in SIoT using ML techniques, leading to a listing of future directions presented in Section 5. The conclusions are summarized in Section 6.

2. Satellite IoT overview

SIoT uses satellites' global coverage to reach devices in less accessible regions, creating a vast network of connected devices using

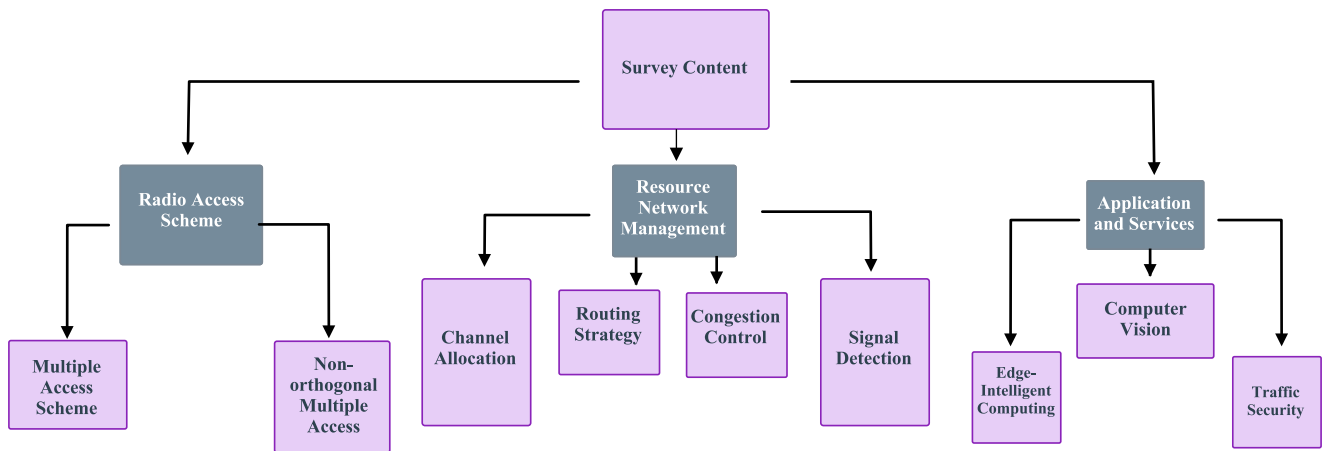

Fig. 1. Coverage of topics reviewed.

satellite platforms acting as gateways or relays. This section introduces the orbital and architectural context and frames SIoT into indirect and direct IoT flavors.

2.1. SIoT orbits

In SIoT, satellites are typically deployed in two distinct orbits: Geostationary Earth Orbit (GEO) and Low Earth Orbit (LEO). Each orbit offers unique advantages and faces specific challenges, making the choice of orbit crucial for the design and implementation of SIoT systems.

Geostationary Orbit (GEO). GEO satellites orbit the Earth at a velocity that matches its rotation, allowing them to remain fixed over a particular point on the equator at an altitude of approximately 35,786 km. This fixed position enables GEO satellites to provide continuous and stable connectivity over a large geographic area, typically covering about one-third of the Earth's surface. The high altitude of GEO satellites allows them to offer wide coverage with fewer satellites, making them ideal for broadcasting and long-distance communications. However, the significant distance also increases latency and signal degradation, disadvantaging real-time applications and high-speed data transfer.

Low Earth Orbit (LEO). On the other hand, LEO satellites orbit at much lower altitudes, typically between 160 km and 1000 km above the Earth's surface. These satellites travel at high velocities of around 7 km/s, resulting in shorter orbital periods and more frequent passes over a given location. LEO satellites provide intermittent connectivity at predictable intervals, which can benefit applications requiring low latency and high-speed data transmission. The proximity to the Earth's surface reduces latency and signal loss, making LEO satellites well-suited for real-time communications, Earth observation, and Internet of Things (IoT) applications. However, the limited coverage area of individual LEO satellites necessitates the deployment of prominent constellations to achieve continuous global coverage.

Constellations. When LEO satellites are deployed in a constellation, they can provide and ensure continuous coverage and connectivity by maintaining a network of satellites that work together to cover the entire globe. This approach involves carefully coordinating and managing satellite orbits to ensure seamless connectivity handover as satellites move in and out of view of ground stations and IoT devices. LEO constellations, such as those proposed by SpaceX (Starlink), OneWeb, and Amazon (Project Kuiper), aim to deliver global high-speed internet access and connect remote and underserved areas. However, IoT-specific constellations are on the launch pad of start-up companies like Sateliot, Kineis, and others. The deployment of large-scale LEO constellations presents challenges related to collision avoidance, spectrum management, and the sustainability of the space environment due to the increased risk of space debris.

2.2. SIoT architectures

Fraire et al. propose a novel space-terrestrial IoT architecture (STEREO) that can be seen in Fig. 2. This architecture identifies two primary deployment cases for implementing SIoT: Direct-to-Satellite IoT (DtS-IoT) and Indirect-to-Satellite IoT (ItS-IoT). These deployment strategies are designed to complement each other, forming an interconnected global network. The choice between these approaches depends on the geographical area and the specific application requirements.

Indirect-To-Satellite Internet of Things (ItS-IoT). This scenario is ideal for rural areas with a high density of IoT devices. ItS-IoT relies on dedicated ground gateways to establish an indirect connection between IoT devices and the satellite. These gateways typically communicate with GEO satellites, which maintain a fixed position relative to the Earth, making them well-suited for stable, long-term connections. ItS-IoT links to LEO are also possible but less common. This setup significantly reduces IoT devices' energy consumption, extending their operational lifespan. However, integrating terrestrial and space protocols to ensure seamless communication across the hybrid network structure is a major challenge. In addition, the terrain and local conditions might make establishing ground infrastructure challenging, but GEO satellites can serve as effective backhaul solutions for these gateways. This stable position in the sky allows high-gain antennas and reliable power sources, such as solar panels, to support long-range communications with the satellite.

Direct-To-Satellite Internet of Things (DtS-IoT). DtS-IoT is suitable for remote and inaccessible regions where deploying ground IoT gateways is impractical or impossible. In this scenario, IoT devices directly connect to LEO satellites, which orbit between 160 km and 1000 km at altitudes. This connection benefits environmental monitoring, maritime operations, and disaster management in areas where terrestrial networks are unavailable or compromised. LEO satellites are preferred due to their proximity to Earth, allowing for lower latency and better signal strength than GEO satellites. However, the high velocity of LEO satellites (approximately seven km/s) means that the coverage area and the served devices change frequently. To ensure continuous connectivity, multiple LEO satellites must be deployed in constellations. Dense constellations are necessary for uninterrupted connectivity applications, while sparse constellations can suffice for delay-tolerant applications. This approach reduces the number of satellites needed, thus lowering costs and complexity. The critical challenge in DtS-IoT involves managing the dynamic and varying communication channels as satellites move quickly across the sky. This requires advanced scheduling and resource management techniques to ensure reliable data transmission and reception. Additionally, inter-satellite links (ISLs) in dense constellations enable coordinated data relay, enhancing the overall network efficiency and coverage [20].

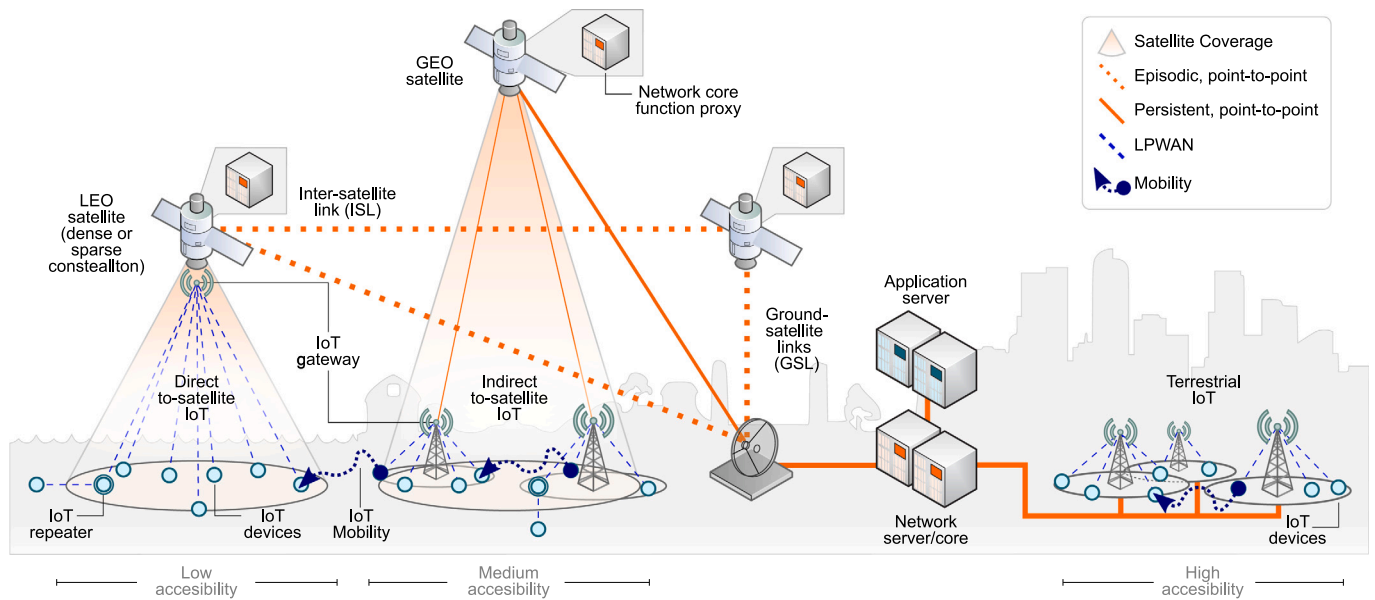

Fig. 2. STEREO architecture showcasing ItS-IoT and DtS-IoT approaches [8].

Latency and coverage considerations. While terrestrial fixed infrastructure can enable lower-latency, real-time data collection for IoT applications in areas with good coverage, satellite constellations introduce additional complexities that can impact latency and real-time capabilities [2]. As noted by Fraire et al. LEO satellite constellations used for IoT connectivity have periodic coverage patterns that can introduce delays when waiting for a satellite to pass over a sensor's location [20]. However, strict real-time requirements are not always necessary for many IoT use cases. In these scenarios, satellite constellations' global coverage and flexibility can provide significant advantages over the high costs of deploying and maintaining fixed terrestrial infrastructure, especially in remote or challenging environments [19]. Centenaro et al. highlights that satellite IoT is particularly well-suited for delay-tolerant applications such as environmental monitoring, asset tracking, and agricultural sensing, where periodic data collection is sufficient [11]. Furthermore, recent advancements in satellite technology and constellation designs are working to minimize latency issues. For instance, dense LEO constellations like those proposed by companies such as Starlink and OneWeb aim to provide more continuous coverage, potentially reducing wait times for satellite passes [1]. Additionally, hybrid terrestrial-satellite IoT architectures are being explored to leverage the strengths of both systems, providing low-latency connectivity where available and global reach where needed [8].

2.3. SIoT technologies

In the rapidly evolving field of SIoT, various technologies have emerged as critical enablers of efficient communication and data transmission. Among these, LoRa/LoRaWAN and NB-IoT stand out for their distinct capabilities and applications within SIoT networks. This introduction provides a concise overview, setting the reader up for the detailed discussions of LoRa/LoRaWAN and NB-IoT.

LoRa/LoRaWAN. It is an LPWAN technology that has gained significant interest in the IoT research community in recent years. LoRa is a proprietary technology at the physical layer, which may impose some economic constraints. It uses Chirp Spread Spectrum (CSS) modulation to manage interference, providing broader coverage than alternatives (e.g., NB-IoT). At the link layer, LoRa uses a protocol called LoRaWAN, which supports several modes of operation [21]. The most common application scenario, Class-A, is an asynchronous, Pure ALOHA-based protocol that provides maximum battery life and is mandatory for all

LoRaWAN devices. It supports bidirectional traffic through a receive window after the completion of the uplink transmission. Class-B devices synchronize to the network through beacons broadcasted by gateways and then open receive windows at regular intervals. Finally, Class-C has a continuous receive window, which requires a sufficient power supply.

NB-IoT. It is a technology provided by 3GPP and part of Release 13 [22]. NB-IoT is also integrated into Long-Term Evolution (LTE) and operates on licensed radio spectrum [23]. It can function as a dedicated carrier and occupy bandwidth within a wide-band LTE carrier. This technology guarantees higher data rates than other LPWA technologies, enabling the capture of videos and images for fine-grained control. However, applying LTE over satellites requires complex coding and synchronous signaling protocol techniques, which are unsuitable for resource-constrained scenarios like SIoT.

2.4. SIoT challenges

Considering the STEREO architecture [8], several open research challenges must be addressed when combining satellite technologies with IoT features.

Cultural. This is one of the biggest challenges that SIoT needs to overcome. The space community tends to focus on the trajectories and actions of dynamic systems, while the terrestrial IoT sector prioritizes the cost of end devices.

Space infrastructure. The different types of orbits complicate the evaluation of space infrastructure. The differences between LEO and GEO involve constraints related to launch and deployment costs. Since GEO satellites are more exposed to risks, they are much more attractive for testing new space technologies such as LoRa/LoRaWAN and NB-IoT.

Mobility. SIoT networks need to address the mobility of gateways in orbit, particularly in sparse constellations, which are more prone to disconnections. NB-IoT offers important mobility features such as handover management and roaming. On the other hand, LoRaWAN seems well-suited for sparse constellations without a handover process.

Medium access protocols. SIoT needs to scale current IoT protocols to handle thousands of end devices. However, it can use the predictable LEO satellite trajectories to learn traffic patterns, allowing for data aggregation and scheduling. This can enhance performance and reduce energy waste in new access control schemes.

mMTC. Current satellite capabilities provide significant advantages for meeting the demands of mMTC in large-scale IoT deployments, mainly through their ability to cover vast areas and support a massive number of connected devices [24,25]. These attributes have made satellite-based solutions increasingly attractive to researchers and industry professionals. However, several challenges remain. The literature identifies the most critical issue as the efficient use of resources during data transmission, which is vital for prolonging the lifespan of IoT devices. This area's inefficiency can lead to unnecessary retransmissions, increasing energy consumption and reducing sensor lifespan. While existing MAC protocols are crucial in mitigating these issues, they often struggle to maintain transmission efficiency when the number of devices exceeds certain thresholds. This leads to significant drops in transmission rates and increased energy usage.

3. Emerging techniques and machine learning methods in SIoT

Machine Learning is a part of artificial intelligence (AI) that uses previous data to make machines *learn*. Simply put, ML finds correlations in previous data and uses that knowledge to make better decisions. Unlike traditional AI, which uses several techniques to simulate human intelligence, ML focuses on algorithms that cause that system to learn and adapt. In recent years, given the increase in computation potential, ML's popularity has grown; this is reflected in the new domains of current applications, such as healthcare, finance, and education, among others. Due to all these reasons, the increase in ML applications in the SIoT domain, especially in access schemes, resources, and networks, is noticeable.

There is a wide variety of ML techniques, and choosing the appropriate technique depends mainly on the nature and data type. For example, suppose the data is composed of images. The application should probably be based on Convolutional Neural Networks (CNNs) since their features allow them to detect image patterns better than other techniques. This section briefly introduces concepts and several ML techniques applied in the SIoT domain, describing their main advantages, characteristics, and limitations. We are not limited to introducing traditional techniques but also present emerging ML techniques from recent years, such as Transformer, Computer Vision, and Federated Learning. Fig. 3 shows the classification of different types of ML that can be used in the SIoT domain. Each ML technique displayed in our overview can potentially address many problems. For example, different NNs are versatile and can be applied to tasks such as classification, image recognition, and processing sequence data. Advanced architectures based on NNs, such as Transformers, have recently been developed to achieve even higher performance in complex tasks. However, these advanced techniques often require substantial computational resources, which can be a limitation in specific scenarios. Transfer learning has emerged as a powerful approach to mitigate this challenge by allowing pre-trained models to be adapted to new tasks with significantly reduced computational demands. Furthermore, RL is particularly well-suited for solving problems where the environment is dynamic and may change over time, a characteristic that makes it highly attractive for SIoT applications. The integration of NN with RL has further enhanced the ability of these models to learn and adapt in such environments, leading to more effective and robust solutions.

We also group the state-of-the-art ML techniques into these categories to provide a better-detailed overview of them, which enables a clearer understanding of their contributions to the SIoT domain.

3.1. Deep learning and neural network

Artificial Neural Network is a powerful technique that tries to mimic the biological neural process. It analyzes and processes data to detect or recognize patterns and perform specific tasks such as pattern recognition, classification, and regression [26].

Multi-layer perceptron. The most common type of neural network is the Multi-Layer Perceptron (MLP), composed of an input, hidden, and output layer. MLP uses back-propagation as a training algorithm, updating the weights using gradient descent methods to minimize a previously defined loss function. With the continuous increase of computational potential, new types of specialized Neural Networks were proposed that introduce additional features that overcome several limitations of original NNs, especially when dealing with certain data types, such as images and text. To overcome these limitations, new types of specialized Neural Networks were proposed.

Convolutional neural network. Convolutional Neural Network (CNN) was initially proposed for the image recognition task [27]. The design of this type of network is made up of convolutional layers, pooling layers, and fully connected layers. In the convolutional layers, filters are applied to images to capture and recognize new patterns as edges and textures. The pooling layers are focused on reducing dimension data through pooling operations. Finally, the fully connected layers at the network's end integrate the data to perform the final task.

Recurrent neural networks. While CNN is centered on working with images, another type of Neural Network focuses on sequential data. Recurrent Neural Network (RNN) was proposed to detect and identify temporal dependencies, which are essential in this data type. This feature converts RNN into an essential method for tasks such as text processing and speech recognition, among others [28]. However, RNN [29] suffers from the famous vanishing gradient problem, which is generated at the moment to process long data sequences. A Long-Short-Term Memory (LSTM) network was proposed to mitigate these difficulties by introducing new mechanisms such as forget, input, and output gates that enable the neural network to maintain the input's long-term dependencies.

Spiking neural networks. Recently, another type of neural network has begun to gain researchers' attention. Spiking Neural Networks (SNN) are considered the third generation of Neural Networks since they can mimic the behavior of human brains besides the structure, such as traditional NN [30]. The most famous and traditional SNN architecture comprises a set of spiking neurons connected to others through synapse interconnections. Each spiking neuron has a membrane potential that, in a very similar way to a biological neuron, adds incoming values over time. Once it achieves a predefined threshold, the neuron will generate a spike to connected neurons [31]. Various DL solutions based on SNN have also been proposed in recent years. Spiking CNNs are also planted to integrate the benefits of SNN and CNN with high performance in classification tasks [32,33]. There have also been works with excellent results integrating recurrent networks with SNN [34].

3.2. Transfer learning

Transfer learning is an advanced technique that combines the knowledge acquired from a previously trained model as the initial point for a new second model that aims to solve a similar task [35]. One primary step of this technique is fine-tuning, a process that adjusts the weights of the new model to solve the new task. Transfer Learning, besides saving time and resources, increases the performance of ML models when there is not much data available for training.

3.3. Transformer

The Transformer is a famous Neural Network architecture originally proposed in the translation domain [36]. Through the years, its popularity has increased due to its excellent performance, especially when working with sequential data, which generated several proposals on new domains besides translation, such as Computer Vision [37], Healthcare [38,39], and Satellite Communications [40], among others. Compared to CNN or RNN, Transformer employs attention mechanisms

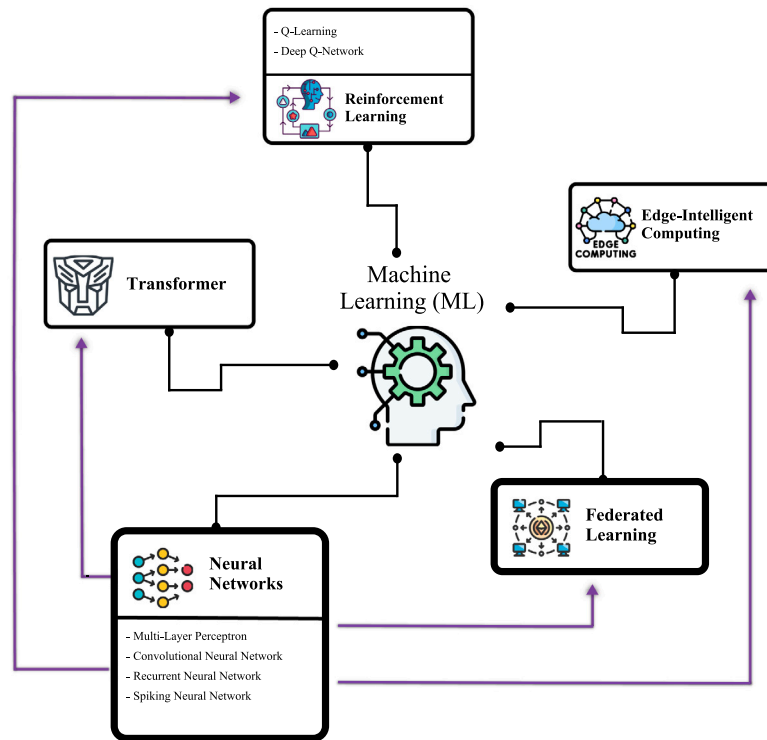

Fig. 3. Classification of ML techniques addressed on the survey.

to represent the relations between input and output. This mechanism allows the model to give attention to several parts of the input at once, which helps it find the relations in the input, even if they are not in sequence. This is why the Transformer's performance is better than that of neural network-based models. As a result, Transformers and new proposes based on it have become the new state-of-the-art basis for many applications.

3.4. Reinforcement Learning

Reinforcement Learning (RL) is a promising ML technique focused on an agent's constant interaction with its environment. We can define the RL problem as a tuple (S, A, P, R) , where S refers to the state space, A to the action space, and P is the state transition probability. R is the immediate reward of an action. The training process in RL can be described as an iterative interaction between the components mentioned before. It can be summarized as follows: an agent observes the environment and uses it to choose an action that gives him an immediate reward. The agent's main goal is to learn a behavior that maximizes the reward received over time. The most traditional and famous algorithm used in RL is Q-Learning, but in recent years, a new approach called Deep Reinforcement Learning (DRL) has been proposed. It combines the benefits of traditional RL with the potential of DL solutions. This new approach replaces the traditional Q-Learning table with alternatives based on DL, such as deep-Q Networks and Long-Short-Term Memory. The main benefit of DQL is that they have a better performance on high-dimensional spaces, as we can see in economics [41], biological [42], and, as we can see in this work, in the SIoT domain.

3.5. Emerging techniques in SIoT

Federated learning. Federated Learning (FL) is a new paradigm of machine learning that aims to preserve data privacy by enabling the model to be trained across decentralized devices. It was initially proposed by Google [43] as a way to predict new users' text input using information

from Android devices without sharing local data. This technique differs from traditional training, in which the data is centralized into a single repository. FL ensures the data remains on local devices and only shares the model updates. The original process of FL [44] is described as follows: firstly, each device gets the current version of the global model that will be improved by a local training phase using the device's local data to generate a set of updated model weights. Then, these updated weights are sent to the cloud, where they are averaged to create a new version of the global model. Finally, this entire process is repeated until the current version of the global model achieves the performance required. These characteristics are very suitable for many domains, for example, in the healthcare domain [45], industrial engineering [46], and more recently in satellite communications [47], where data security is crucial.

Edge-intelligent computing. Edge computing (EC) is a new paradigm focused on performing processing and calculations closer to the data source to improve service quality. This characteristic solves some challenges in IoT applications [48]. For example, computing on the edge close to the end device reduces the latency, which is crucial in real-time and multimedia applications. Another energy consumption challenge is that new power management strategies can be introduced using the EC feature. More recently, and with the rise in popularity of DL, a new approach based on EC was proposed. Edge-intelligent computing emerges as a way to apply ML solutions directly to edge devices. This new approach allows the processing of real-time data, which is crucial for applications that require fast online learning. Additionally, Edge-Intelligent Computing achieves higher learning accuracy than on-device learning [49]. There are several applications of this approach, such as video analytics [50], speech recognition [51], and smart cities [52], among others.

4. ML solutions for SIoT

This section explores the works integrating ML in SIoT, detailing the challenges and the problems solved. We are focusing primarily on the ML application. Fig. 4 presents a graphic distribution of ML techniques

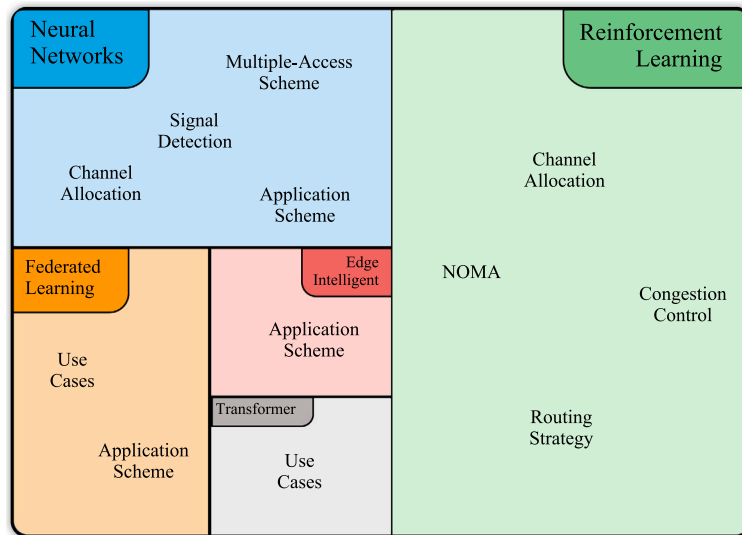

Fig. 4. ML technique to SIoT Application Scope.

with their applications in the SIoT domain. Additionally, Table 2 details an overall classification of the reviewed works highlighting several SIoT applications. The table details crucial aspects and features in the reviewed works, including the origin of the dataset they use, the training and inference node (space or ground), and the core metrics of the approach. The remainder of this section revises and discusses each of the presented papers and details their core characteristics.

Among the SIoT objectives, we identified the following categories. On the one hand, multiple access schemes and Non-orthogonal access schemes refer to mechanisms that allow multiple devices to share a common resource. On the other hand, channel allocation, routing strategy, congestion control, and signal detection refer to efficient resource management to improve the performance of the SIoT network.

With these categories in mind, Fig. 5 summarizes the types of applications, ML techniques, and the number of works that use them in the remainder of this survey. Two main insights emerge from Fig. 5. First, RL is the most frequently employed ML method in the SIoT field. This predominance is largely due to RL's capacity to enable agents to learn optimal policies in dynamic and complex environments. It is well-suited for real-time decision-making scenarios like resource and network management and radio access schemes. The adaptability of RL in these contexts ensures that it can effectively manage the inherent variability and unpredictability of SIoT environments. Secondly, the increasing application of FL frameworks is notable. FL is particularly advantageous when communication efficiency and data privacy are paramount, such as in distributed IoT networks. FL addresses privacy concerns by enabling localized model training and reducing the need to transmit raw data while minimizing bandwidth usage. This makes FL ideal for SIoT applications prioritizing secure and efficient data processing. In contrast, other ML methods may be less frequently applied due to their limitations in handling the specific challenges posed by SIoT environments. For example, while effective in static settings, traditional supervised learning methods may struggle with the dynamic and distributed nature of SIoT systems, where continuous learning and adaptation are critical.

4.1. Radio access schemes

This section addresses ML works related to multiple access and non-orthogonal access schemes in SIoT. A multiple access scheme is a method that grants multiple end devices the ability to share a channel simultaneously. The most common multiple schemes are Time Division Multiple Access (TDMA), Frequency Division Multiple Access (FDMA),

and Code Division Multiple Access (CDMA). On the other hand, Non-Orthogonal Multiple Access (NOMA) refers to a multiple access method that allows multiple end devices to transmit simultaneously at the same radio resource using different power levels. This feature introduces multi-user interference. To cope with this problem, it employs a detection algorithm such as Successive Interference Cancellation (SIC) to decode and separate multiplexed signals [70].

Alternatively, similar works have addressed the traffic prediction task on Satellite Networks. For instance, in [71], a prediction framework using LSTM is proposed to predict traffic in the covered area of a LEO Satellite Network. Another work [72] uses LSTM and Generative Adversarial Networks to create a highly efficient prediction model for satellite network traffic. These studies further highlight the effectiveness of ML techniques in optimizing satellite network performance by enhancing traffic management and reducing delays.

In [53], an alternative scheme based on combined free/demand assignment multiple access (CFDAMA) was proposed; its objective is to combine DL techniques with the original CFDAMA to improve the general performance. This proposal is focused on the time delay T between uplink and downlink frames to the satellites. The end device is in a continuous burst data traffic process during T . They use a CLSTM Neural Network, which is a combination of CNN and LSTM neural networks, and transfer learning to predict the traffic data during the period T and be able to reduce the accumulation of data packets since these predictions are considered at the moment of receiving user access requests and calculate the total slots required. To achieve this, they order the input data based on time, split it into several data sequences, and use the first sample to train a CLSTM network, then make a transfer learning process of the parameters to a new network and fine-tune it and use the new model to predict the future traffic. The CLSTM network consists mainly of 8 input nodes, 24 output nodes, and 1000 hidden nodes. Finally, this process is repeated until all samples are used in training. The simulation scenario to validate their proposal comprises Inmarsat synchronous satellites and ground IoT devices created through STK. The data traffic is generated using MATLAB. Both are integrated using OPNET to get the simulation results. The final results show that their proposal performs better than classical alternatives such as CFDAMA-PA (Pre-Assigned Request) and CFDAMA-PB (Piggy-Backing request) in accumulating queue packages and end-to-end delay.

Sun et al. [54] focus on the importance of the Successive Interference Cancellation (SIC) of non-orthogonal multiple access (NOMA) for SIoT. They propose an alternative allocation scheme based on a DL algorithm (DL-PA) and aim to predict the optimal SIC decoding order

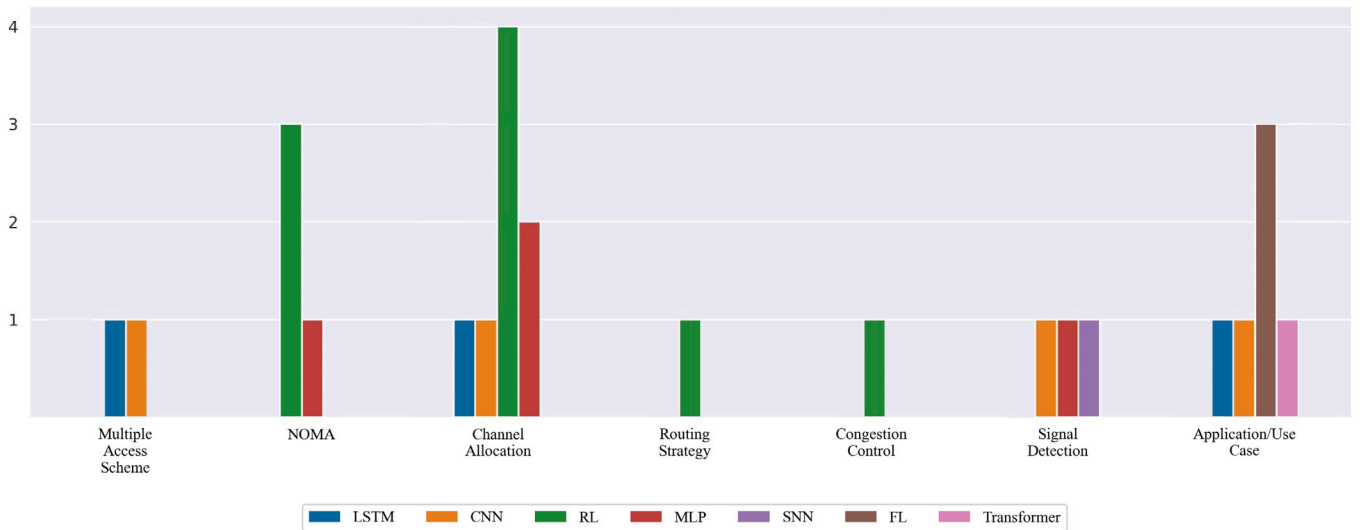

Fig. 5. Cardinality of ML techniques by SIoT application.

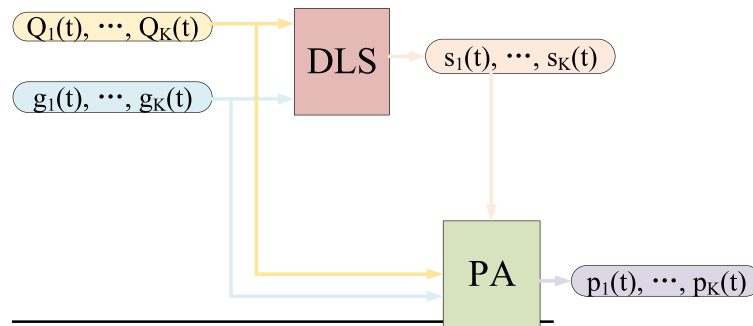

Fig. 6. Framework of DL-PA (Sun et al. 2019) [54].

and power allocation since these are limited resources on the satellites. Given that calculating the optimal order through conventional analysis is extremely difficult, their proposal employs the benefits of DL. As can be seen in Fig. 6, the proposal uses the queue state (Q), the channel state (g), and the optimal decoding order of each combination to train a Deep Neural Network (MLP with three hidden layers) to approximate the optimal SIC decoding order (S). The data used to validate their proposal was generated by simulation. Finally, they compared their predictions against an alternative algorithm. The results indicate that they achieved an efficient allocation power following the SIC decoder order prediction by the neural network model of the SIoT NOMA.

Another work [55] is focused on guaranteeing the freshness of information, so they proposed the concept of Age of Information (AoI) that represents the elapsed time since the generation of status to the present. To minimize the AoI of the Satellite IoT Network, they propose a DRL age-optimal power allocation that obtains the optimal power allocation rules. Their proposal is based on a Deep Q-Network where the set of the current value of AoI of end devices conforms to the state space. The action space is conformed by each possible combination of power allocation coefficients allocated by the satellite to the devices, and the function reward is directly related to AoI variation, which means if AoI decreases, more reward will be obtained from the agent. They use a simulation scenario to evaluate their proposal and compare it against alternatives. The baselines used are the NOMA-G scheme, where the satellite allocates power given the channel conditions, and the MAF scheme, where the power is allocated given the current value of AoI. The numerical results demonstrate that their proposal significantly outperforms these baselines.

Another work based on DRL applied to a NOMA system is [56] in the SIoT domain. They propose multibeam random access, splitting the satellite coverage into several beams, and assume that adjacent beams share some parts of the region. The devices in these regions can send/receive data in two periods of the two shared beams. Additionally, they define the number of replicas of the packet that the device transmits as degrees. The authors aim to optimize the Random Access policy using a DRL algorithm that assists the NOMA-Slotted Aloha protocol (DRL-NSA). The proposal uses a Deep Q-Network in which the state space represents a set of real-time service requirements for all the devices supported by the multi-beam LEO satellite, the action space is the degrees for the type of device, and the reward is a function that denotes the average throughput in a beam. After simulation, they compare their proposal against other state-of-the-art schemes and demonstrate the best average throughput performance.

In [57], after a previous analysis, they found that optimizing the number of relays and available channels is crucial to increasing the system performance in Satellite IoT. They design a random access protocol based on NOMA to improve the throughput in an ultra-dense IoT network (Satellite IoT scenario). Their proposal (QL-NOMA) uses a traditional Q-learning algorithm and aims to allocate devices in the correct timeslot channel. Each end device (IoT device) represents the agent, the state-action pair is represented by timeslot-channel access, and the reward is a single feedback bit that indicates the success or failure of the transmissions. They compare their proposal against some baselines such as Slotted Aloha-NOMA and DQL-JRSAC [73] and outperform them in normalized throughput.

Table 2
Applications of ML in SIoT and details for each evaluated paper.

SIoT application type	Paper	Year	Description	ML type	Dataset	Training place	Inference place	SIoT objective	ML metric
Multiple access scheme	[53]	2021	Predict the traffic data	LSTM, CNN, TL	Simulation by MATLAB, STK, and OPNET	Not specified	In space	Data traffic prediction	RMSE, MAPE, MAE
Non-orthogonal access scheme	[54]	2019	Predict the optimal SIC decoding order in NOMA	MLP	Created through simulation	–	Not specified	Optimal SIC decoding order	Accuracy, MSE
	[55]	2022	Minimize the Age of Information	DRL	Created through simulation	–	Not specified	Average AoI performance	–
	[56]	2023	Optimize the random access policy	DRL	Created through simulation	–	Not specified	Optimize random access policy	–
	[57]	2022	Random access protocol	RL	–	–	–	–	–
Channel allocation	[58]	2020	Optimize the energy-efficient channel allocation	DRL, MLP	Created through simulation using Gaussian distribution for tasks	–	In space	Reduce energy consumption	–
	[59]	2022	Optimize the channel allocation operation	DRL, LSTM	A dataset that consists of 1000 samples of traffic user request	–	In space	Efficient channel allocation	–
	[60]	2020	Reduce the average transmission latency	DRL, MLP	Created through simulation where traffic of sensors follows a random distribution	–	In space	Reduce average transmission latency	–
	[61]	2022	Optimize the channel allocation based on QoS	DRL, CNN	Created through simulation with 10,000 IoT devices distributed	–	–	Optimize channel allocation considering QoS	–
Routing strategy	[62]	2021	Propose a routing strategy	DRL	Created through simulation using ONE simulator with 110 ground nodes distributed uniformly	–	Both	Delivery rate, average delay, and overhead ratio	–
Congestion control	[63]	2019	Reduce the congestion generated by DTN technique	RL	Created through simulation with IoT devices that generate data bundles according to the Poisson distribution	–	Not specified	Bundle abort rate	–
Signal Detection	[64]	2023	Reduce symbol error rate (SER) and power consumption	SNN, CNN, MLP	Created through MATLAB simulator	Not specified	Not specified	High symbol error rate (SER)	MSE
Applications and services	[47]	2022	Propose methods to integrate ML in SIoT using FL	FL, CNN	Created through simulation with MNIST dataset to final task	Both	Both	Resource limitations and latency	Accuracy
	[65, 66]	2019	Edge-Intelligent computing	Edge-Intelligent	Created through MATLAB simulator, CloudSim 4.0	On ground	In space	Delay in data transmissions	–
	[67]	2022	Detect cyberattacks in real-time	FL, LSTM	Two datasets that contain several types of attacks such as DDoS, Injection, and Backdoor attacks	On ground	On ground	Detect cyber-attacks	Accuracy, prec., rec., and F-measure
	[68]	2023	Propose a framework to apply SIoT in a use case	Transformer	Use a dataset of 665 images to the final task	On ground	In space	Image recognition	Accuracy, F1-score
	[69]	2023	Propose a framework to apply SIoT and FL	FL	–	–	–	–	–

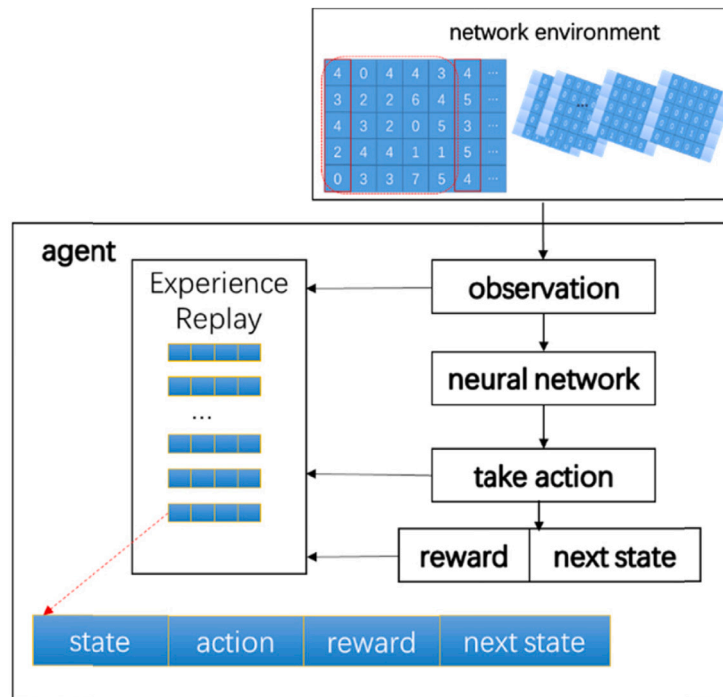

Fig. 7. Architecture of DeepCA (Zhao et al. 2020) [58].

4.2. Resource and network management

Resource management in Satellite IoT ensures an efficient and reliable connection between many end devices and satellites. An efficient channel allocation to minimize interference, a routing strategy to increase the delivery ratio, signal detection to reduce energy consumption, and congestion control can all play crucial roles in enhancing the performance of Satellite IoT. We classify ML papers into the abovementioned categories and analyze them as follows.

4.2.1. Channel allocation

In [58], highlight the importance of an efficient resource scheduling scheme due to the resource shortage in the SIoT domain. Even though there are alternative schemes that improve the efficiency of energy (e.g., TDMA), they do not consider the vast number of devices and data transmission requests. For this, the authors propose DeepCA, an approach based on RL used for an energy-efficient channel allocation in SIoT. The proposal architecture is shown in Fig. 7. DeepCA employs a neural network instead of traditional Q-Learning, where the satellite performs as the agent. The state space includes information about the user tasks (size and location), the action space represents the available channels to allocate new tasks, and the reward functions reflect the energy consumption and the quality of services (QoS). Since satellite patterns are unknown, the tasks are simulated using Gaussian distribution. Final numerical results evidence that their proposal can reduce energy consumption compared to traditional algorithms such as the random select algorithm and two greedy algorithms.

Durga et al. [59] focus on the problem related to the irregular distribution of users and the lowest adaptability of the satellite of users among the beams that appear in the SIoT domain. Consequently, they introduce a DRL approach (DRL-LSTM) based on the demand to perform an efficient channel allocation operation using the user density in each beam. Unlike the previous one, this proposal uses LSTM neural networks' ability to work with sequential and historical data. It uses a dataset of 1000 samples of traffic user requests. In DR-LSTM, the state space includes information about the user requests, the action space represents the available channels to allocate new user requests,

and the reward is also related to the power of consumption and the satisfaction rate. The Fig. 8 details the interaction of these components. They compared their proposal against other baselines such as random power allocation (RPA), two greedy algorithms, and DeepCA [58], and the evidence that DRL-LSTM overcomes others regarding power consumption and satisfaction rate.

Another significant study addressing the channel allocation problem in the SIoT domain is presented in [60]. In this work, the authors introduce a novel method called CA-DRL, which stands for Channel Allocation using DRL. The CA-DRL approach leverages the principles of DRL to optimize channel allocation dynamically and efficiently. This method is designed to enhance the overall performance and efficiency of channel allocation processes by learning and adapting to the varying conditions of the communication environment. By applying DRL techniques, CA-DRL can intelligently allocate channels to maximize network throughput and minimize interference, demonstrating its effectiveness in complex and changing network scenarios. The authors highlight the importance of data transmission efficiency since it impacts the lifetime of sensors or end devices, a crucial factor in the SIoT domain. Current MAC protocols handle this problem, but the success rate is drastically affected when the number of users overpasses a specific limit. The main disadvantage of these protocols is that they do not consider the amount of data transmitted, which may generate high latency and delay. Their proposal is based on minimizing the average transmission latency using a DRL technique based on an MLP Network where the satellite represents the agent, and the state space contains information about the user request, such as the number of sensor tasks processing, bandwidth, duration of new tasks; the action spaces correspond to the available channels to allocate, and the reward function reflects the delay on the transmission, so a high delay receives a lower reward and vice versa. The data traffic of sensors is simulated following a random distribution. Fig. 9 shows the interaction of the main components of their proposal. Finally, they compared their proposal against two classical principles: First Come First Service (FCFS) and Random Access Control (pure ALOHA). The results show that CA-DRL reduces the transmission delay compared with the baselines.

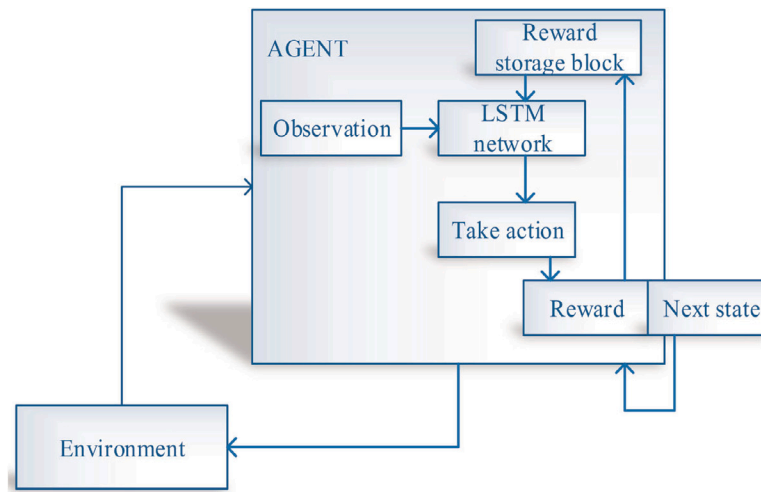

Fig. 8. Architecture of DR-LSTM (Durga et al. 2022) [59].

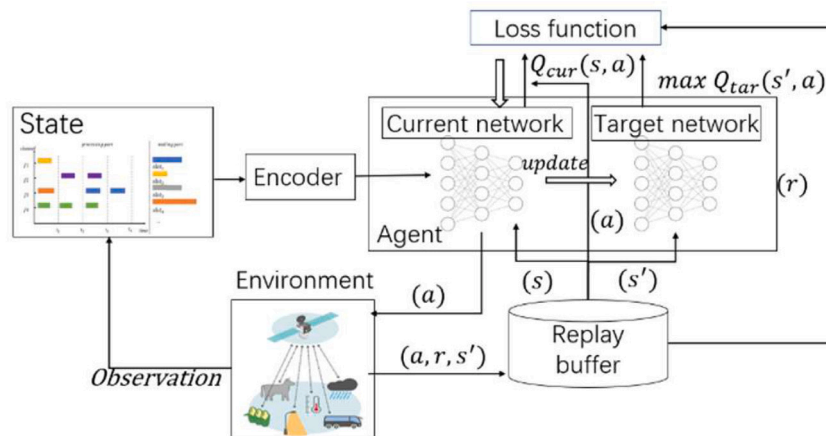

Fig. 9. Architecture of CA-DRL (Liu et al. 2020) [60].

In [61], authors focus on the channel allocation problem considering the power consumption, resource efficiency, and especially in fulfilling the QoS requirements in a Satellite IoT uplink scenario. They highlight that there are heterogeneous devices with several QoS requirements. For example, in the streaming service, the QoS requirement is focused on data transmission rates; however, in monitoring services, the QoS centers on delay and reliability. Their proposal (DRL-QoS-RA) is based on DRL that uses a CNN, where the state space includes information about channel quality, current arrival terminals, terminals that have been allocated previously, and the terminals that are still sending information; the action space is related to the available channel, and the transmit power of terminal; and the reward considers the QoS constraints detailed before. The CNN design comprises an input layer, two convolutional layers, and two fully connected layers. Additionally, they consider the application of transfer learning as a method to increase the proposal's performance. They did an initial training using a simulation environment and then fine-tuned the last layer of the NN in the final deployment. With this approach, they can take advantage of the benefits of transfer learning and reduce the energy consumption of a complete training process on deployment after a simulation with 10,000 distributed IoT terminals, whose request arrival follows the Poisson distribution. Finally, comparing their proposal against popular techniques such as genetic algorithm, random method, and DRL-RA [58] indicates that DRL-QoS-RA has better performance, which may be due to the focus on the QoS requirement.

4.2.2. Network traffic and signal management

Zhou et al. [62] address the critical issue of routing strategy in Satellite IoT, emphasizing the importance of considering energy consumption in data packet forwarding. Traditional routing strategies are inadequate for SIoT due to the many end devices involved. To overcome this limitation, the authors propose a novel routing strategy utilizing a double Q-Learning algorithm, a variation of Q-Learning that has not been extensively applied to routing tasks. In their approach, satellites and end devices are treated as nodes, representing the agents within the system. The state space encompasses all deployed nodes, while the action space includes each nearby node that a single node can reach. The reward mechanism is designed to account for the hop count, thereby effectively controlling energy consumption. To evaluate the performance of their proposed strategy, Zhou et al. use the ONE simulator to create an environment comprising a satellite and 110 uniformly distributed ground nodes. They benchmark their approach against several state-of-the-art alternatives, including those presented by Spyropoulos et al. [74], Sharma et al. [75], and Wu et al. [76]. The results of this comparison demonstrate that the proposed routing strategy outperforms the alternatives in terms of delivery rate, average delay, and overhead ratio across various failure probabilities. Similar work has been carried out in [77], where an efficient routing strategy for LEO Satellite Networks is proposed using an RL approach. The simulations and results validate the effectiveness of this approach.

In [63] focus on Delay/Interrupt Tolerant Network (DTN) which is a technique designed to guarantee that end devices can communicate between them even when the delay increases, it is based on the principle of storage-and-forward process to reduce the packet loss rate, and ensure reliable delivery. Since this approach requires high storage resources, it can create congestion in the Satellite IoT scenario. ML can be applied to develop congestion control mechanisms. Their proposal reduces the congestion generated by DTN using multi-hop packets and proposes an algorithm based on RL (LGFCC) to use storage resources effectively. These features can reduce congestion in the SIoT scenario and increase QoS. They simulate an environment with five IoT devices that generate data bundles following the Poisson distribution. Finally, they use the simulation to evaluate the performance of their proposal, showing that the LGFC algorithm performs better in reducing the packet abort rate in the SIoT scenario.

Dakic et al. [64] focus on the high interference caused by a large number of transmissions, which generate a high symbol error rate (SER). To solve the elevated SER and also reduce the power consumption, they propose a DL solution to perform an effective signal detection (chirp signal detection) using Spiking Neural Network focus on LoRa modulation, which is the most popular chirp-base modulation in the Satellite IoT domain. The simulation scenario comprises several IoT ground devices operating in the LoRa modulation scheme. Each device tries to connect to the nearest satellite using pure ALOHA as an access model, taking advantage of its simplicity and low power consumption. They compared several DL methods based on SNN. The first one is a basic SNN that encodes the data to be used in a spike network. In the training phase, the membrane potential is increased in the correct class and otherwise is reduced. The second propose is called CSNN, and it is based on the combination of SNN and CNN to take advantage of its best feature extraction and power efficiency; naturally, CSNN performs convolution operations on spikes, and the filters are specially designed to detect patterns in spike sequences. The third proposal adapts the idea of HybNet [78] to be implemented using SNN. Additionally, these three methods are compared against ANN, CNN, and original HybNet, respectively, to demonstrate the effectiveness and applicability of SNN. The authors use a MATLAB simulator [79] to create chirp I/Q signals and use them as training datasets. The numerical results evidence that the spiking-based networks have impressive performance and low power consumption, especially the CSNN technique.

4.3. Applications and services

While the Radio Access, Resource, and Network Management categories discussed above focus on the SIoT network infrastructure and its operations, the Applications and Services category centers on utilizing ML techniques to process and analyze the data payload transported by the SIoT system. This category addresses explicitly how ML can enhance the value of the data collected by SIoT devices, enabling advanced applications such as predictive maintenance, environmental monitoring, and intelligent resource management. These ML-driven applications leverage the rich data sets provided by SIoT to deliver actionable insights and optimize various operational aspects across different industries.

4.3.1. Edge-intelligent computing applications

In [47], authors discuss the application of FL over Satellite IoT constellation. The authors highlight the inefficiency of collecting/sending data to a centralized location to train an ML model due to resource limitations and latency. Motivated by the above reasons and the benefits of Federated Learning, they propose four methods to integrate ML in a Satellite IoT context. The first method consists of classical centralized learning (CL) deployed in the cloud. This method receives raw data from devices directly and develops an ML model; in this method, the satellites are used as relays to re-transmit data. In the second method, the model is developed directly in the satellites. The downside is that

this method requires extensive computation power and satellite storage capability. The third method uses the benefits of FL and is very similar to the first method. However, in this new technique, only the model weights are shared through the network, making it an alternative with more data protection and security and improving latency than the previous ones. Finally, the fourth method is also inspired by FL, but in this approach, the model's weights are allocated in the satellite, and the network can run FL without data sharing. Fig. 10 shows the four possible strategies detailed before. As we can infer, methods that use FL reduce the latency, increase privacy and security, and have the lowest energy consumption on the satellite. To evaluate the performance of the methods based on FL, they solve the digit recognition task employing the very famous MNIST dataset. They split the dataset into N pieces; each is only available on one of the devices. The results indicate that FL under the LEO constellation in the SIoT context has practical accuracy on the MNIST dataset, gaining the abovementioned features.

In [65,66], the authors perform a detailed evaluation of the application of Edge Intelligent Computing in the Satellite IoT domain using the computational power onboard the satellite to achieve edge intelligent computing. They propose a new application scheme composed of three layers: Satellite IoT Edge, Satellite IoT Cloud, and the ground cloud center. The architecture of these three layers can be seen in Fig. 11. The Satellite IoT Edge layer has potential computing, storage, and the ability to communicate between similar satellites to request assistance in some tasks. The Satellite IoT Cloud layer has more computational power than the previous one (CPU, GPU) and assumes the role of a Satellite IoT data center. The ground cloud center layer assumes the function of a big computing center with great computational power and storage. A satellite can collect data and perform the DL task. However, if the satellite does not have sufficient computational power or resources, the data and task can be transmitted to a nearby Satellite IoT edge node or cloud node. In this proposal, the initial training of the DL model can be performed on the ground and uploaded. As detailed before, they set up a simulation scenario where each layer has technical features. Then, to verify the performance of the DL model in any of the edge intelligent computing devices, they calculate the delay of several models in any of these layers. The authors create a simulation environment using MATLAB and *Cloudsim 4.0* [80] to perform the training process. After the evaluation, they concluded that DL models can run with outstanding performance and low delay.

Moustafa et al. [67] highlight the increase in cyberattacks against Satellite IoT environments and networks. There are several types of security weaknesses, such as vulnerable satellites that can become a target because of the low security in satellite networks, DDoS attacks through network communications or interfering with the firmware and operating system, and power depletion attacks that affect the performance of satellites. The authors propose a Federated Learning-based deep learning framework (DFSat) to detect cyberattacks in real-time from satellite networks in the Satellite IoT domain. Their proposal evaluates and detects abnormal patterns in traffic using a variation of LSTM called Bidirectional LSTM, a type of RNN that can analyze and use the input information in forward and backward directions. They validate their proposal using two datasets that contain several types of attacks such as DDoS, Injection, Backdoor attacks, etc. [81,82]. The numerical results are compared against state-of-the-art methods, showing that DFSat performs better in accuracy, precision, and recall.

4.3.2. Monitoring and security

In [68] work proposes a framework to apply Satellite IoT in conjunction with a case study of image recognition in smart agriculture (MobileVit) that consists of aphid detection and infestation severity on lemon leaves, which is a type of smart agriculture that has gained much attention from academia and industry in recent years. On the other hand, their framework is composed of three layers. The first one consists of sensors that collect physical variables such as temperature, humidity, and soil composition. The intermediate layer consists of

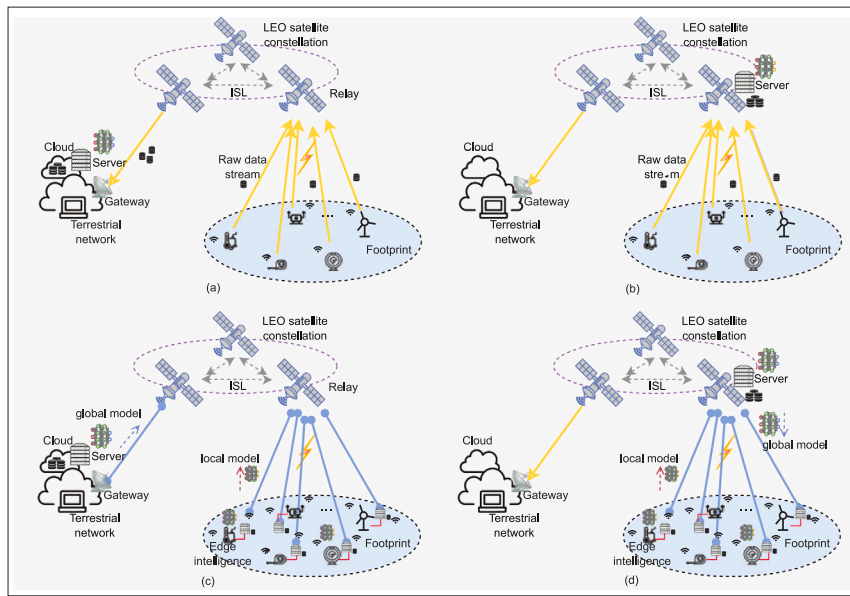

Fig. 10. Strategies proposed (Chen et al. 2022) [47].

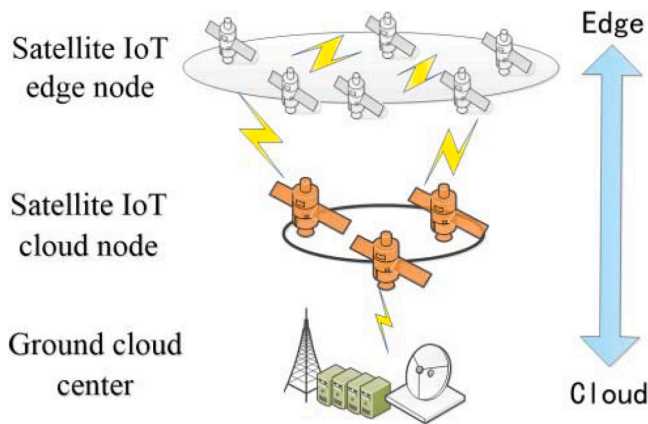

Fig. 11. Strategies proposed (Wei et al. 2019) [65,66].

UAV devices that collect data from sensors, take images of the leaves, and send them to the satellite. The last layer comprises the satellite that should be equipped with the DL model previously trained on the ground. This model infers whether the leaves are infected based on the images collected. While this application specifically involves image analysis, integrating sensor data — such as temperature, humidity, and soil composition — could enhance the model’s accuracy and broaden its applicability to other areas, such as environmental monitoring or precision agriculture. The three-layer framework is shown in Fig. 12. Their proposal uses Vision Transformer, a version focused on image recognition that showed better performance than models based on CNNs [83] and uses a dataset of images composed of 665 images between healthy and diseased leaves. They compared the results of their proposal against MobileNetV2 [84] and demonstrated better performance and are more suitable for an in-orbit deployment.

Uddin et al. propose a framework based on Federated Learning for Satellite-IoT domain [69] to enhance data security and privacy by employing an ML model to filter and discard malicious traffic. They consider two ways of connecting the end devices and the satellites. The first establishes direct communication, and the satellite redirects the data to a base station for processing. The second establishes a

connection between a ground gateway and a base station. Their proposal incorporates the software-defined networking (SDN) approach, which enables network management of elements and functionalities. It consists of three layers: the application layer includes all user applications. The control layer boards the network controller and the management of its elements, and the infrastructure layer includes the network devices. In this proposal, each end device will generate its local model employing any ML algorithm, send the update weights to the controller that aggregates them, and generate a new global model. This new model sets out the new policies using the traffic patterns detected by each end device. This process can be seen in Fig. 13.

5. Identified gaps

Despite significant progress in applying ML in the SIoT domain, several gaps remain, which we identified through an extensive review of various works. This section briefly introduces and examines the most pressing research gaps in the current literature.

Optimization of satellite resources. Even though the reviewed works already focused on this research direction, this remains a critical aspect of effective communication between IoT end devices and the satellite. There is a constant request to maximize the efficiency and usage of the limited satellite resources since the satellite will have more resources to perform other complex tasks. Future research could focus on applying ML techniques to optimize the allocation process of satellite resources. For example, applications may use ML techniques to detect power usage patterns and establish operational conditions to optimize consumption and improve transmission and user experience performance. We have found a gap in this application’s scope that needs to be addressed. It is essential to emphasize the need for future applications to be robust and scalable.

Security and privacy. This research direction has been poorly explored, even though the current SIoT networks can transmit sensitive and private data. Future research should consider applying ML techniques in the SIoT domain to complement and improve the security of transmissions, protecting them from cyber-attacks and unauthorized access attempts. For example, an ML model can be developed to detect patterns in SIoT network traffic and identify suspicious patterns that may compromise the network’s security and integrity. Another crucial topic concerns end-user device privacy; ML applications should be designed

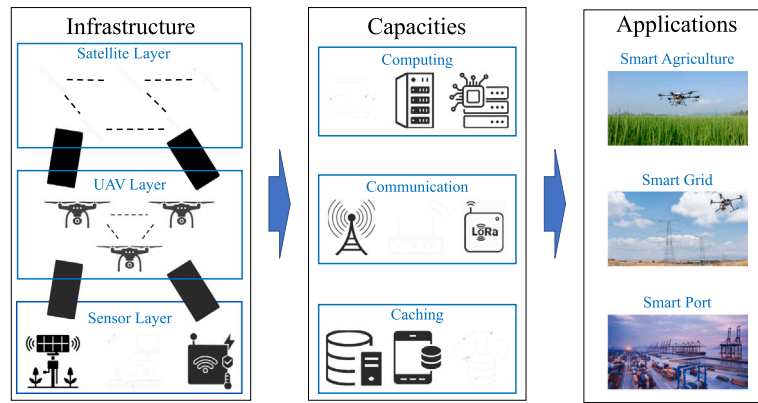

Fig. 12. The proposed three-layer FL framework (Liu et al. 2023) [68].

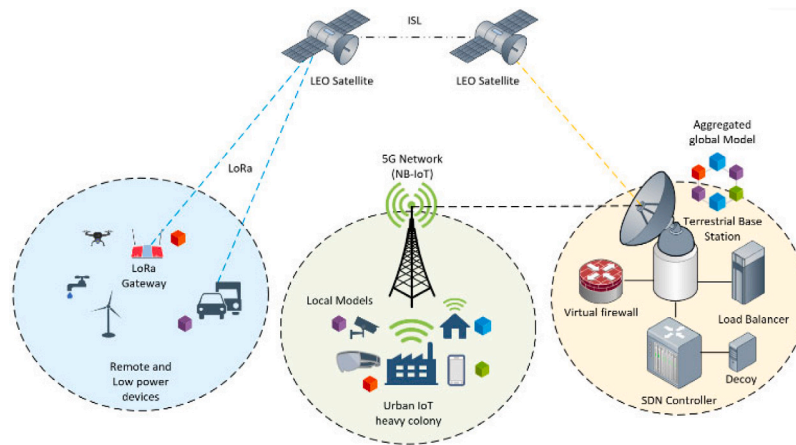

Fig. 13. The proposed FL framework (Uddin et al. 2023) [69].

with this principle. This survey paper reviewed articles focused on the application of FL, which allows ML models to be trained locally and improves security and privacy. Future research should optimize these privacy techniques and guarantee consistent model performance. These are important research directions to provide a reliable SIoT network, which is essential for building trust and encouraging the worldwide adoption of this type of network.

Execution and integration. Many studies overlook the practical execution of training and inference, often failing to distinguish between space-based and ground-based processing. Additionally, a notable lack of integration between ML techniques and SIoT-specific metrics impedes the evaluation of real-world applicability and performance. Furthermore, many papers disregard the limited computational resources available on orbiting satellites, an oversight that raises concerns about the feasibility and efficiency of proposed solutions in operational environments. Furthermore, it is crucial to consider the different orbital options available for SIoT applications, as the choice between Low Earth Orbit (LEO) and Geostationary Earth Orbit (GEO) satellites hinges on the application’s specific requirements. LEO satellites offer high resolution and superior communication quality, making them ideal for real-time data and high-precision applications. However, their high velocity and consequent need for complex networking introduce challenges such as increased costs and the Doppler effect. In contrast, GEO satellites provide more stable and continuous coverage, albeit with lower resolution and higher latency. This makes them suitable for applications where stability and cost-effectiveness are prioritized over resolution. Moreover, evaluating the existing ground-based and space-based IoT infrastructure in the regions where SIoT solutions are to be deployed is important. Not all scenarios necessitate SIoT, and the joint

development of these technologies should be prioritized to ensure the efficient and effective deployment of IoT solutions. Understanding each application’s specific requirements and the available infrastructure’s capabilities allows a balanced and optimized deployment strategy to be developed, maximizing resource efficiency and overall performance.

6. Opportunities and challenges

The rapid advancement in satellite communication and IoT technologies and the increasing adoption of ML in the SIoT domain have opened numerous potential future research and development directions and associated challenges. This section details the most promising research directions in Satellite IoT, focusing on high-impact areas and some of the most critical challenges identified through the extensive review process.

6.1. Opportunities

This survey has identified several promising opportunities for advancing SIoT by integrating machine learning techniques. These opportunities include the following.

Integration of advanced ML techniques. The constant growth in the machine learning area generates new techniques that consistently outperform the current state-of-the-art technology. Even though these techniques have been proposed in other fields, they have not yet been adapted to suit SIoT conditions and improve performance and reliability. In previous sections, widely used ML approaches were explored and surveyed. However, there are some advanced techniques that SIoT would benefit from them. These new underexplored techniques can

address emerging challenges, such as predictive maintenance, lifespan optimization, anomaly detection, and more, or enhance the performance of existing solutions by replacing the current ML techniques. Examples of such advanced techniques for which a gap was identified include:

1. *Graph Neural Networks (GNNs)*: GNNs can be utilized to model and analyze the complex relationships and interactions in satellite constellations and IoT networks, leading to more efficient routing and resource allocation strategies.
2. *Generative Adversarial Networks (GANs)*: GANs can generate realistic synthetic data for training and testing ML models, instrumental in scenarios where real-world data is scarce or expensive to collect.
3. *Combination of RL and GNN (RL+GNN)*: Combining RL with GNN can significantly enhance the capabilities of SIoT systems. When combined, RL+GNN can provide a robust framework for SIoT. This hybrid approach allows for continuous learning and adaptation to changing network conditions, improving the overall performance and reliability of SIoT systems, minimizing latency, reducing energy consumption, and enhancing data throughput.

Optimization of satellite resources. Even though the reviewed works already focused on this research direction, this remains a critical aspect of effective communication between IoT end devices and the satellite. There is a constant request to maximize the efficiency and usage of the limited satellite resources since the satellite will have more resources to perform other complex tasks. Future research could focus on applying ML techniques to optimize the allocation process of satellite resources. For example, applications may use ML techniques to detect power usage patterns and establish operational conditions to optimize consumption and improve transmission and user experience performance. We have found a gap in this application's scope that needs to be addressed. It is essential to emphasize the need for future applications to be robust and scalable.

Security and privacy. This research direction has been poorly explored, even though the current SIoT networks can transmit sensitive and private data. Future research should consider applying ML techniques in the SIoT domain to complement and improve the security of transmissions, protecting them from cyber-attacks and unauthorized access attempts. For example, an ML model can be developed to detect patterns in SIoT network traffic and identify suspicious patterns that may compromise the network's security and integrity. Another crucial topic concerns end-user device privacy; ML applications should be designed with this principle. This survey paper reviewed articles focused on the application of FL, which allows ML models to be trained locally and improves security and privacy. Future research should optimize these privacy techniques and guarantee consistent model performance. These are important research directions to provide a reliable SIoT network, which is essential for building trust and encouraging the worldwide adoption of this type of network.

Space-terrestrial integration. The transition from 4G to 5G and 6G networks represents a significant technological leap, promising unprecedented advancements in connectivity, speed, and the potential for innovative applications. One of the most promising directions for 6G is its integration with Satellite-IoT, giving birth to the so-called Non-Terrestrial Networks (NTNs) [85]. NTNs aim to provide comprehensive coverage and support for many IoT applications, even in the most remote and underserved areas. 6G networks are expected to offer data rates up to 100 times faster than 5G, extremely low latency, and support for massive machine-type communications. Recent research has explored various aspects of 6G and Satellite-IoT integration [86,87]. Architectural advancements in 6G, such as Network Functions Virtualization (NFV), Software-Defined Networking (SDN), and Multiple Input Multiple Output (MIMO) technologies, are being investigated for

their potential to enhance network capabilities and efficiency. This integration is crucial for enabling IoT applications in remote and rural areas, maritime regions, and during disaster recovery operations where traditional networks may be unavailable. However, from the papers we identified, we have not found research that highlights the value of ML in achieving the desired NTN integration.

Emerging sIoT applications. Exploring different specific applications is a crucial research direction since they prove the benefits and potential of applying ML in the SIoT domain. As we detailed before, there are a wide variety of application areas. SIoT can support various applications, including environmental monitoring, disaster management, precision agriculture, intelligent logistics, and global tracking systems. Still, very little research was found to address these domains from the SIoT perspective. For instance, environmental sensors distributed over large, inaccessible areas can transmit data via satellite to central servers for real-time analysis and decision-making. Similarly, precision agriculture can benefit from satellite IoT by using remote sensors to monitor soil moisture, crop health, and weather conditions, optimizing resource use and boosting productivity. Another interesting application could be disaster natural predictions (i.e., floods, tornadoes, among others). The data collected from specific IoT devices from several regions can be exploited by ML techniques to generate predictions. This application could significantly impact the since it can reduce economic and human losses.

6.2. Challenges

This survey has uncovered several significant challenges in the SIoT domain that hinder the practical application of machine learning techniques. These challenges include the lack of datasets and the limited onboard resources.

Lack of datasets. Unlike many other domains where vast amounts of labeled data are readily available for training and validation, the SIoT domain faces a significant challenge due to data scarcity and restricted availability. This limitation is paradoxical, given the immense potential for data collection in SIoT applications. As a result, most papers in this field rely on synthetic or simulated data, which often fails to capture the full complexity and variability of real-world scenarios. This reliance on non-representative data hampers the development and evaluation of robust ML models, making it difficult to achieve accurate and reliable results in practical implementations. Recent efforts have been made to consolidate and create datasets that reflect realistic traffic for various use cases [88]. However, given the increased complexity of space missions, developing sophisticated and customizable simulators remains a promising approach. For instance, MeteorNet [89] introduces a constellation simulator capable of accurately emulating the full protocol stack of NTN scenarios. MeteorNet also allows for the customization of the emulator to gather relevant network data, enabling the generation of sophisticated and customizable synthetic datasets that can be leveraged for ML solutions.

Limited onboard resources. The limited computational capabilities of satellites present a significant challenge for deploying ML models in the SIoT domain. One primary constraint is radiation hardening, a necessary process to protect satellite electronics from the harsh space environment. This protection often results in using less advanced, lower-performance hardware compared to terrestrial systems. Additionally, the lack of air in space prevents efficient heat dissipation, limiting the processing power that can be safely used without risking overheating. These factors collectively restrict the computational resources available on board. Developing lightweight, efficient ML algorithms that can operate within these constraints while still delivering robust performance for SIoT applications is crucial. This survey showed that most papers about ML in SIoT do not properly consider this challenge. There has been notable progress in the evolution of technological

resources onboard satellites, as discussed in [90]. One promising approach to overcoming these limitations is satellite cooperation, where multiple satellites work together to share computational loads and resources, as explored in [91].

7. Conclusions

This comprehensive review of Machine Learning (ML) applications in the Satellite Internet of Things (SIoT) domain highlights the critical roles that various ML techniques have played across numerous studies. Through our analysis, we have identified key trends, challenges, and opportunities that will shape the future of this field. The main conclusions are summarized as follows:

- Reinforcement Learning (RL) is the most widely used ML technique in SIoT, particularly effective in critical network components such as power allocation, congestion control, and access control.
- Adaptability and Effectiveness of RL: RL's adaptability and effectiveness make it well-suited for the unique challenges of space applications.
- Emerging Popularity of Alternative ML Techniques: There is a growing interest in alternative ML techniques like Federated Learning, especially for addressing critical issues such as security and privacy in SIoT.
- Integration of ML into SIoT: Integrating ML techniques in SIoT is pivotal for developing more efficient, adaptive, and resilient applications, which is crucial in advancing the domain.
- Addressing Gaps and Challenges: To enhance the performance and reliability of SIoT applications, it is essential to tackle the gaps and challenges identified in previous sections.
- Opportunities for Future Research: This paper identifies numerous future research and development opportunities that promise significant advancements in integrating ML in SIoT.

In conclusion, the application of ML in SIoT is still in its early stages, but its potential is vast. Addressing the identified gaps and capitalizing on emerging opportunities will be vital to driving innovation and ensuring that SIoT networks can meet the demands of future applications. By integrating advanced ML techniques and addressing the challenges outlined, researchers and practitioners can make significant strides in developing the next generation of intelligent, resilient, and secure SIoT systems.

CRedit authorship contribution statement

Alexander Y. Choquenaira-Florez: Writing – review & editing, Writing – original draft, Validation, Investigation, Formal analysis, Data curation, Conceptualization. **Juan A. Fraire:** Writing – review & editing, Writing – original draft, Supervision, Methodology, Investigation, Conceptualization. **Hannah B. Pasandi:** Writing – review & editing, Conceptualization. **Hervé Rivano:** Supervision.

Declaration of competing interest

The authors declare that they have no known competing financial interests or personal relationships that could have appeared to influence the work reported in this paper.

Acknowledgments

This project has received funding from the European Union's Horizon 2020 research and innovation program under the Marie Skłodowska-Curie grant agreement No 101008233 (MISSION) and the French National Research Agency (ANR) under the project ANR-22-CE25-0014-01.

Data availability

No data was used for the research described in the article.

References

- [1] I. Leyva-Mayorga, B. Soret, M. Röper, D. Wübben, B. Matthesen, A. Dekorsy, P. Popovski, LEO small-satellite constellations for 5G and beyond-5G communications, *Ieee Access* (2020) <http://dx.doi.org/10.1109/ACCESS.2020.3029620>.
- [2] J.A. Fraire, S. Céspedes, N. Accettura, Direct-to-satellite IoT-a survey of the state of the art and future research perspectives: Backhauling the IoT through LEO satellites, in: *International Conference on Ad-Hoc Networks and Wireless*, Springer, 2019.
- [3] S. Al-Sarawi, M. Anbar, R. Abdullah, A.B. Al Hawari, Internet of things market analysis forecasts, 2020–2030, in: *2020 Fourth World Conference on Smart Trends in Systems, Security and Sustainability, Worlds4, IEEE*, 2020, <http://dx.doi.org/10.1109/Worlds450073.2020.9210375>.
- [4] Y. Chauvin, D.E. Rumelhart, *Backpropagation: Theory, Architectures, and Applications*, Psychology Press, 2013.
- [5] F. Fourati, M.-S. Alouini, Artificial intelligence for satellite communication: A review, *Intell. Converg. Netw.* (2021) <http://dx.doi.org/10.23919/ICN.2021.0015>.
- [6] G. Stock, J.A. Fraire, T. Mömke, H. Hermanns, F. Babayev, E. Cruz, Managing fleets of LEO satellites: Nonlinear, optimal, efficient, scalable, usable, and robust, *IEEE Trans. Comput.-Aided Des. Integr. Circuits Syst.* 39 (11) (2020) 3762–3773.
- [7] H.T. Siegelmann, E.D. Sontag, On the computational power of neural nets, in: *Proceedings of the Fifth Annual Workshop on Computational Learning Theory*, Association for Computing Machinery, 1992, <http://dx.doi.org/10.1145/130385.130432>.
- [8] J.A. Fraire, O. Iova, F. Valois, Space-terrestrial integrated Internet of Things: Challenges and opportunities, *IEEE Commun. Mag.* (2022) <http://dx.doi.org/10.1109/MCOM.008.2200215>.
- [9] S.M. Tahsien, H. Karimipour, P. Spachos, Machine learning based solutions for security of Internet of Things (IoT): A survey, *J. Netw. Comput. Appl.* (2020) <http://dx.doi.org/10.1016/j.jnca.2020.102630>.
- [10] M.S. Mahdavejad, M. Rezvan, M. Barekatian, P. Adibi, P. Barnaghi, A.P. Sheth, Machine learning for Internet of Things data analysis: A survey, *Digit. Commun. Netw.* (2018) <http://dx.doi.org/10.1016/j.dcan.2017.10.002>.
- [11] M. Centenaro, C.E. Costa, F. Granelli, C. Sacchi, L. Vangelista, A survey on technologies, standards and open challenges in satellite IoT, *IEEE Commun. Surv. Tutor.* (2021) <http://dx.doi.org/10.1109/COMST.2021.3078433>.
- [12] X. Chen, Z. Xu, L. Shang, Satellite Internet of Things: challenges, solutions, and development trends, *Front. Inf. Technol. Electron. Eng.* (2023) <http://dx.doi.org/10.1631/FITEE.2200648>.
- [13] N. Ahmadi, Review of terrestrial and satellite networks based on machine learning techniques, *J. Soft Comput. Decis. Support. Syst.* (2020).
- [14] A. Khanna, S. Kaur, Internet of things (IoT), applications and challenges: a comprehensive review, *Wirel. Pers. Commun.* (2020) <http://dx.doi.org/10.1007/s11277-020-07446-4>.
- [15] A.A. Laghari, K. Wu, R.A. Laghari, M. Ali, A.A. Khan, A review and state of art of Internet of Things (IoT), *Arch. Comput. Methods Eng.* (2021) <http://dx.doi.org/10.1007/s11831-023-09985-y>.
- [16] J. Tournier, F. Lesueur, F. Le Mouël, L. Guyon, H. Ben-Hassine, A survey of IoT protocols and their security issues through the lens of a generic IoT stack, *Internet Things* (2021) <http://dx.doi.org/10.1016/j.iot.2020.100264>.
- [17] M. Iqbal, A.Y.M. Abdullah, F. Shabnam, An application based comparative study of LPWAN technologies for IoT environment, in: *2020 IEEE Region 10 Symposium, TENSYP, 2020*, <http://dx.doi.org/10.1109/TENSYP50017.2020.9230597>.
- [18] S. Uguwanyi, G. Paul, J. Irvine, Survey of IoT for developing countries: Performance analysis of LoRaWAN and cellular nb-IoT networks, *Electron.* (2021) <http://dx.doi.org/10.3390/electronics10182224>.
- [19] M. De Sanctis, E. Cianca, G. Araniti, I. Bisio, R. Prasad, Internet of Things via satellite: Review and future perspectives, *IEEE Internet Things J.* 3 (5) (2016) 822–835.
- [20] J.A. Fraire, S. Henn, F. Dovic, R. Garello, G. Taricco, Sparse satellite constellation design for LoRa-based direct-to-satellite Internet of Things, in: *GLOBECOM 2020-2020 IEEE Global Communications Conference, IEEE*, 2020, <http://dx.doi.org/10.1109/GLOBECOM42002.2020.9348042>.
- [21] LoRa Alliance Technical Committee, LoRaWAN 1.1 Specification, v1.1 ed., LoRa Alliance, 2017.
- [22] Link Labs, Inc., A comprehensive look at low power, wide area networks. <http://cdn2.hubspot.net/hubfs/427771/LPWAN-Brochure-Interactive.pdf>.
- [23] D. Rohde, J. Schwarz, Narrowband Internet of Things, 2016, <https://www.rohde-schwarz.com/us/applications/narrowband-internet-of-things-application-note56280-314242.html>.

- [24] M.A. Ullah, K. Mikhaylov, H. Alves, Enabling mMTC in remote areas: LoRAWAN and LEO satellite integration for offshore wind farm monitoring, *IEEE Trans. Ind. Inform.* (2021) <http://dx.doi.org/10.1109/TII.2021.3112386>.
- [25] M.A. Ullah, K. Mikhaylov, H. Alves, Massive machine-type communication and satellite integration for remote areas, *IEEE Wirel. Commun.* (2021) <http://dx.doi.org/10.1109/MWC.100.2000477>.
- [26] O.I. Abiodun, A. Jantan, A.E. Omolara, K.V. Dada, N.A. Mohamed, H. Arshad, State-of-the-art in artificial neural network applications: A survey, *Heliyon* (2018) <http://dx.doi.org/10.1016/j.heliyon.2018.e00938>.
- [27] Y. LeCun, B. Boser, J.S. Denker, D. Henderson, R.E. Howard, W. Hubbard, L.D. Jackel, Backpropagation applied to handwritten zip code recognition, *Neural Comput.* (1989) <http://dx.doi.org/10.1162/neco.1989.1.4.541>.
- [28] H. Salehinejad, S. Sankar, J. Barfett, E. Colak, S. Valaee, Recent advances in recurrent neural networks, 2017, <http://dx.doi.org/10.48550/arXiv.1801.01078>, arXiv preprint arXiv:1801.01078.
- [29] S. Hochreiter, J. Schmidhuber, Long short-term memory, *Neural Comput.* (1997) <http://dx.doi.org/10.1162/neco.1997.9.8.1735>.
- [30] W. Maass, Networks of spiking neurons: the third generation of neural network models, *Neural Netw.* (1997) [http://dx.doi.org/10.1016/S0893-6080\(97\)00011-7](http://dx.doi.org/10.1016/S0893-6080(97)00011-7).
- [31] A. Tavanaei, M. Ghodrati, S.R. Kheradpisheh, T. Masquelier, A. Maida, Deep learning in spiking neural networks, *Neural Netw.* (2019) <http://dx.doi.org/10.1016/j.neunet.2018.12.002>.
- [32] S.R. Kheradpisheh, M. Ganjtabesh, S.J. Thorpe, T. Masquelier, STDP-based spiking deep convolutional neural networks for object recognition, *Neural Netw.* (2018) <http://dx.doi.org/10.1016/j.neunet.2017.12.005>.
- [33] S.R. Kheradpisheh, M. Ganjtabesh, T. Masquelier, Bio-inspired unsupervised learning of visual features leads to robust invariant object recognition, *Neurocomputing* (2016) <http://dx.doi.org/10.1016/j.neucom.2016.04.029>.
- [34] R. Costa, I.A. Assael, B. Shillingford, N. De Freitas, T. Vogels, Cortical microcircuits as gated-recurrent neural networks, *Adv. Neural Inf. Process. Syst.* (2017).
- [35] K. Weiss, T.M. Khoshgoftaar, D. Wang, A survey of transfer learning, *J. Big Data* (2016) <http://dx.doi.org/10.1186/s40537-016-0043-6>.
- [36] A. Vaswani, et al., Attention is all you need, *Adv. Neural Inf. Process. Syst.* (2017).
- [37] S. Jamil, M. Jilil Piran, O.-J. Kwon, A comprehensive survey of transformers for computer vision, *Drones* (2023) <http://dx.doi.org/10.3390/drones7050287>.
- [38] A.Y. Florez, L. Scabora, D.M. Eler, J.F. Rodrigues, APEHR: Automated prognosis in electronic health records using multi-head self-attention, in: 2021 IEEE 34th International Symposium on Computer-Based Medical Systems, CBMS, IEEE, 2021, <http://dx.doi.org/10.1109/CBMS5207.2021.00077>.
- [39] S. Nerella, et al., Transformers in healthcare: A survey, 2023, <http://dx.doi.org/10.48550/arXiv.2307.00067>, arXiv preprint arXiv:2307.00067.
- [40] M. Kaselimi, A. Roumeliotis, A. Papafragkakis, A. Panagopoulos, N. Doulamis, Site diversity switching prediction AT q band using deep learning techniques in satellite communications, in: 2023 IEEE International Conference on Acoustics, Speech, and Signal Processing Workshops, ICASSPW, IEEE, 2023, <http://dx.doi.org/10.1109/ICASSPW59220.2023.10193159>.
- [41] A. Mosavi, Y. Faghan, P. Ghamisi, P. Duan, S.F. Ardabili, E. Salwana, S.S. Band, Comprehensive review of deep reinforcement learning methods and applications in economics, *Math.* (2020) <http://dx.doi.org/10.3390/math8101640>.
- [42] M. Mahmud, M.S. Kaiser, A. Hussain, S. Vassanelli, Applications of deep learning and reinforcement learning to biological data, *IEEE Trans. Neural Netw. Learn. Syst.* (2018) <http://dx.doi.org/10.1109/TNNLS.2018.2790388>.
- [43] B. McMahan, E. Moore, D. Ramage, S. Hampson, B.A. y Arcas, Communication-efficient learning of deep networks from decentralized data, in: *Artificial Intelligence and Statistics*, PMLR, 2017.
- [44] L. Li, Y. Fan, M. Tse, K.-Y. Lin, A review of applications in federated learning, *Comput. Ind. Eng.* (2020) <http://dx.doi.org/10.1016/j.cie.2020.106854>.
- [45] J. Lee, J. Sun, F. Wang, S. Wang, C.-H. Jun, X. Jiang, et al., Privacy-preserving patient similarity learning in a federated environment: development and analysis, *JMIR Med. Inform.* (2018) <http://dx.doi.org/10.2196/medinform.7744>.
- [46] Y.M. Saputra, D.T. Hoang, D.N. Nguyen, E. Dutkiewicz, M.D. Mueck, S. Srikanthswara, Energy demand prediction with federated learning for electric vehicle networks, in: 2019 IEEE Global Communications Conference, GLOBECOM, IEEE, 2019, <http://dx.doi.org/10.1109/GLOBECOM38437.2019.9013587>.
- [47] H. Chen, M. Xiao, Z. Pang, Satellite-based computing networks with federated learning, *IEEE Wirel. Commun.* (2022) <http://dx.doi.org/10.1109/MWC.008.00353>.
- [48] B. Varghese, N. Wang, S. Barbhuiya, P. Kilpatrick, D.S. Nikolopoulos, Challenges and opportunities in edge computing, in: 2016 IEEE International Conference on Smart Cloud, SmartCloud, IEEE, 2016, <http://dx.doi.org/10.1109/SmartCloud.2016.18>.
- [49] G. Zhu, D. Liu, Y. Du, C. You, J. Zhang, K. Huang, Toward an intelligent edge: Wireless communication meets machine learning, *IEEE Commun. Mag.* (2020) <http://dx.doi.org/10.1109/MCOM.001.1900103>.
- [50] J. Wang, et al., Bandwidth-efficient live video analytics for drones via edge computing, in: 2018 IEEE/Acm Symposium on Edge Computing, Sec, IEEE, 2018, <http://dx.doi.org/10.1109/SEC.2018.00019>.
- [51] Z.Q. Lin, A.G. Chung, A. Wong, Edgespechnets: Highly efficient deep neural networks for speech recognition on the edge, 2018, <http://dx.doi.org/10.48550/arXiv.1810.08559>, arXiv preprint arXiv:1810.08559.
- [52] C.C.-H. Hsu, M.Y.-C. Wang, H.C. Shen, R.H.-C. Chiang, C.H. Wen, FallCare+: An IoT surveillance system for fall detection, in: 2017 International Conference on Applied System Innovation, ICASI, IEEE, 2017, <http://dx.doi.org/10.1109/ICASI.2017.7988590>.
- [53] Q. He, Z. Xiang, P. Ren, A CLSTM and transfer learning based CFDMA strategy in satellite communication networks, *Plos One* (2021) <http://dx.doi.org/10.1371/journal.pone.0248271>.
- [54] Y. Sun, Y. Wang, J. Jiao, S. Wu, Q. Zhang, Deep learning-based long-term power allocation scheme for NOMA downlink system in S-IoT, *IEEE Access* (2019) <http://dx.doi.org/10.1109/ACCESS.2019.2926426>.
- [55] Q. Liu, J. Jiao, S. Wu, R. Lu, Q. Zhang, Deep reinforcement learning-assisted NOMA age-optimal power allocation for S-IoT network, in: ICC 2022-IEEE International Conference on Communications, IEEE, 2022, <http://dx.doi.org/10.1109/ICC45855.2022.9839197>.
- [56] H. Yu, H. Zhao, Z. Fei, J. Wang, Z. Chen, Y. Gong, Deep reinforcement learning-based NOMA-aided slotted ALOHA for LEO satellite IoT networks, *IEEE Internet Things J.* (2023) <http://dx.doi.org/10.1109/JIOT.2023.3277836>.
- [57] D.A. Tubiana, J. Farhat, G. Brante, R.D. Souza, Q-learning NOMA random access for IoT-satellite terrestrial relay networks, *IEEE Wirel. Commun. Lett.* (2022) <http://dx.doi.org/10.1109/LWC.2022.3169109>.
- [58] B. Zhao, J. Liu, Z. Wei, I. You, A deep reinforcement learning based approach for energy-efficient channel allocation in satellite Internet of Things, *IEEE Access* (2020) <http://dx.doi.org/10.1109/ACCESS.2020.2983437>.
- [59] S.L. Durga, C. Rajeshwari, K.H. Allehaibi, N. Gupta, N.N. Albaqami, I. Bharti, A.H. Basori, Deep reinforcement learning-based long short-term memory for satellite IoT channel allocation, *Intell. Autom. Soft Comput.* (2022) <http://dx.doi.org/10.32604/iasc.2022.022536>.
- [60] J. Liu, B. Zhao, Q. Xin, H. Liu, Dynamic channel allocation for satellite internet of things via deep reinforcement learning, in: 2020 International Conference on Information Networking, ICOIN, IEEE, 2020, <http://dx.doi.org/10.1109/ICOIN48656.2020.9016474>.
- [61] S. Tang, Z. Pan, G. Hu, Y. Wu, Y. Li, Deep reinforcement learning-based resource allocation for satellite internet of things with diverse QoS guarantee, *Sensors* (2022) <http://dx.doi.org/10.3390/s22082979>.
- [62] J. Zhou, X. Gong, L. Sun, Y. Xie, X. Yan, Adaptive routing strategy based on improved double Q-learning for satellite Internet of Things, *Secur. Commun. Netw.* (2021) <http://dx.doi.org/10.1155/2021/5530023>.
- [63] Z. Wang, J. Zhang, X. Zhang, W. Wang, Reinforcement learning based congestion control in satellite Internet of Things, in: 2019 11th International Conference on Wireless Communications and Signal Processing, WCSP, IEEE, 2019, <http://dx.doi.org/10.1109/WCSP.2019.8928132>.
- [64] K. Dakic, B. Al Homssi, S. Walia, A. Al-Hourani, Spiking neural networks for detecting satellite internet-of-things signals, *IEEE Trans. Aerosp. Electron. Syst.* (2023) <http://dx.doi.org/10.1109/TAES.2023.3334216>.
- [65] J. Wei, S. Cao, Application of edge intelligent computing in satellite Internet of Things, in: 2019 IEEE International Conference on Smart Internet of Things, SmartIoT, IEEE, 2019, <http://dx.doi.org/10.1109/SmartIoT.2019.00022>.
- [66] J. Wei, J. Han, S. Cao, Satellite IoT edge intelligent computing: A research on architecture, *Electron.* (2019) <http://dx.doi.org/10.3390/electronics8111247>.
- [67] N. Moustafa, I.A. Khan, M. Hassanin, D. Ormrod, D. Pi, I. Razzak, J. Slay, DFSat: Deep federated learning for identifying cyber threats in IoT-based satellite networks, *IEEE Trans. Ind. Inform.* (2022) <http://dx.doi.org/10.1109/TII.2022.3214652>.
- [68] J. Liu, W. Jiang, H. Han, M. He, W. Gu, Satellite internet of things for smart agriculture applications: A case study of computer vision, in: 2023 20th Annual IEEE International Conference on Sensing, Communication, and Networking, SECON, IEEE, 2023, <http://dx.doi.org/10.1109/SECON58729.2023.10287508>.
- [69] R. Uddin, S.A. Kumar, Sdn-based federated learning approach for satellite-iot framework to enhance data security and privacy in space communication, *IEEE J. Radio Freq. Identif.* (2023) <http://dx.doi.org/10.1109/JRFID.2023.3279329>.
- [70] A. Balci, R. Sokullu, Massive connectivity with machine learning for the Internet of Things, *Comput. Netw.* (2021) <http://dx.doi.org/10.1016/j.comnet.2020.107646>.
- [71] C. Han, A. Liu, L. Huo, H. Wang, X. Liang, A prediction-based resource matching scheme for rentable LEO satellite communication network, *IEEE Commun. Lett.* (2019) <http://dx.doi.org/10.1109/LCOMM.2019.2955469>.
- [72] J. Cai, S. Song, H. Zhang, R. Song, B. Zhang, X. Zheng, Satellite network traffic prediction based on LSTM and GAN, in: 2023 IEEE 3rd International Conference on Information Technology, Big Data and Artificial Intelligence, ICIBA, 2023, <http://dx.doi.org/10.1109/ICIBA56860.2023.10165616>.
- [73] B. Zhao, G. Ren, X. Dong, H. Zhang, Distributed Q-learning based joint relay selection and access control scheme for IoT-oriented satellite terrestrial relay networks, *IEEE Commun. Lett.* (2021) <http://dx.doi.org/10.1109/LCOMM.2021.3061717>.
- [74] T. Spyropoulos, K. Psounis, C.S. Raghavendra, Spray and wait: an efficient routing scheme for intermittently connected mobile networks, in: Proceedings of the 2005 ACM SIGCOMM Workshop on Delay-Tolerant Networking, 2005, <http://dx.doi.org/10.1145/1080139.1080143>.

- [75] D.K. Sharma, S.K. Dhurandher, I. Woungang, R.K. Srivastava, A. Mohanane, J.J. Rodrigues, A machine learning-based protocol for efficient routing in opportunistic networks, *IEEE Syst. J.* (2016) <http://dx.doi.org/10.1109/JSYST.2016.2630923>.
- [76] C. Wu, T. Yoshinaga, D. Bayar, Y. Ji, Learning for adaptive anycast in vehicular delay tolerant networks, *J. Ambient Intell. Humaniz. Comput.* (2019) <http://dx.doi.org/10.1007/s12652-018-0819-y>.
- [77] Y. Huang, W. Shufan, K. Zeyu, M. Zhongcheng, H. Huang, W. Xiaofeng, A.J. Tang, X. Cheng, Reinforcement learning based dynamic distributed routing scheme for mega LEO satellite networks, *Chin. J. Aeronaut.* (2023) <http://dx.doi.org/10.1016/j.cja.2022.06.021>.
- [78] K. Dakic, B. Al Homssi, M. Lech, A. Al-Hourani, Hybnet: A hybrid deep learning-matched filter approach for iot signal detection, *IEEE Trans. Mach. Learn. Commun. Netw.* (2023) <http://dx.doi.org/10.1109/TMLCN.2023.3270131>.
- [79] B. Homssi, LoRa MATLAB emulator data retrieved from AURIN, 2020.
- [80] R.N. Calheiros, R. Ranjan, A. Beloglazov, C.A. De Rose, R. Buyya, CloudSim: a toolkit for modeling and simulation of cloud computing environments and evaluation of resource provisioning algorithms, *Softw. - Pract. Exp.* (2011) <http://dx.doi.org/10.1002/spe.995>.
- [81] A. Alsaedi, N. Moustafa, Z. Tari, A. Mahmood, A. Anwar, TON_IoT telemetry dataset: A new generation dataset of IoT and IIoT for data-driven intrusion detection systems, *Ieee Access* (2020) <http://dx.doi.org/10.1109/ACCESS.2020.3022862>.
- [82] N. Moustafa, J. Slay, UNSW-NB15: a comprehensive data set for network intrusion detection systems (UNSW-NB15 network data set), in: 2015 Military Communications and Information Systems Conference, MilCIS, IEEE, 2015, <http://dx.doi.org/10.1109/MilCIS.2015.7348942>.
- [83] Y. Zheng, W. Jiang, et al., Evaluation of vision transformers for traffic sign classification, *Wirel. Commun. Mob. Comput.* (2022) <http://dx.doi.org/10.1155/2022/3041117>.
- [84] M. Sandler, A. Howard, M. Zhu, A. Zhmoginov, L.-C. Chen, Mobilenetv2: Inverted residuals and linear bottlenecks, in: Proceedings of the IEEE Conference on Computer Vision and Pattern Recognition, 2018, <http://dx.doi.org/10.48550/arXiv.1801.04381>.
- [85] M. Giordani, M. Zorzi, Non-terrestrial networks in the 6G era: Challenges and opportunities, *IEEE Netw.* 35 (2) (2020) 244–251.
- [86] S. Kota, G. Giambene, 6G integrated non-terrestrial networks: Emerging technologies and challenges, in: 2021 IEEE International Conference on Communications Workshops, ICC Workshops, 2021, <http://dx.doi.org/10.1109/ICCWorkshops50388.2021.9473743>.
- [87] M. Ozger, I. Godor, A. Nordlow, T. Heyn, S. Pandi, I. Peterson, A. Viseras, J. Hollis, C. Raffelsberger, A. Kercek, B. Mölleryd, L. Toka, G. Biczok, R. de Candido, F. Laimer, U. Tarmann, D. Schupke, C. Cavdar, 6G for connected sky: A vision for integrating terrestrial and non-terrestrial networks, in: 2023 Joint European Conference on Networks and Communications & 6G Summit, EuCNC/6G Summit, 2023, <http://dx.doi.org/10.1109/EuCNC/6GSummit58263.2023.10188330>.
- [88] H. Shahid, M.Á. Vázquez, M. Shaat, P. Henarejos, N.T. Quijada, E. Marinu, Open datasets for satellite radio resource control, in: 40th International Communications Satellite Systems Conference, ICSSC 2023, 2023, <http://dx.doi.org/10.1049/icp.2024.0852>.
- [89] C. Rojas, J.A. Fraire, F. Patrone, M. Marchese, Advanced constellation emulation and synthetic datasets generation for non-terrestrial networks, in: 2024 IEEE International Mediterranean Conference on Communications and Networking, MeditCom, IEEE, 2024, <http://dx.doi.org/10.1109/MeditCom61057.2024.10621248>.
- [90] P.-H. Chen, R.L.-T. Cho, The technological trajectory of LEO satellites: Perspectives from main path analysis, *IEEE Trans. Eng. Manage.* (2023) <http://dx.doi.org/10.1109/TEM.2023.3347921>.
- [91] P. Yue, J. An, J. Zhang, J. Ye, G. Pan, S. Wang, P. Xiao, L. Hanzo, Low earth orbit satellite security and reliability: Issues, solutions, and the road ahead, *IEEE Commun. Surv. Tutor.* (2023) <http://dx.doi.org/10.1109/COMST.2023.3296160>.



Alexander Y. Choquenaira-Florez is a PhD candidate at INRIA (France). He got a Master's in Computer Science from the University of Sao Paulo (Brazil). His research focuses on machine learning and deep space networks, adding several papers at international conferences.



Juan A. Fraire is a researcher at INRIA (France) and a guest professor at CONICET-UNC (Argentina) and Saarland University (Germany). Core topics of his interest are near-Earth and deep-space networking and informatics, adding up to more than 100 published papers in international journals and leading conferences. Juan is the co-founder and chair of the Space-Terrestrial Internetworking Workshop (STINT) and participates in diverse joint projects with space agencies (e.g., NASA, ESA, CONAE) and companies in the space sector (e.g., D3TN, Skyloam).

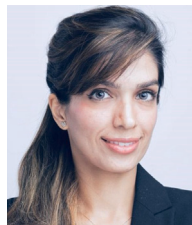

Hannaneh Barahouei Pasandi is a Postdoctoral researcher at Inria and a Fellow Researcher at UC Berkeley's EECS department. Her research interests encompass a wide spectrum of Mobile Systems and Mobile Computing, focusing on systems-based wireless technologies, including Wi-Fi, BLE, LPWAN, and Satellite Communication. Hannah's research is centered around Direct-to-satellite communication, focusing on optimizing data transmission protocols, enhancing signal reliability, and improving the integration of satellite networks with terrestrial IoT systems to achieve seamless global connectivity. She is also working on privacy auditing and mitigation strategies in B5/6G networks with applications in smart package tracking, smart farming, autonomous vehicles, mixed reality environments, and IoT.

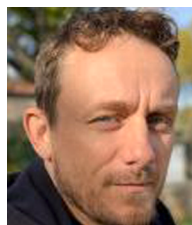

Hervé Rivano is a Full Professor at INSA Lyon and the head of the Inria/INSA Lyon common team Agora of the CITI lab, which focuses on wireless networks in Smart Cities. He obtained his Ph.D. in November 2003 from the University of Nice-Sophia Antipolis and graduated from the Ecole Normale Supérieure de Lyon. His research interests include combinatorial optimization applied to network design and provisioning. He focuses on capacity/energy tradeoffs for urban cellular and mesh network design and low-cost and dense wireless sensor networks for environmental sensing.