



**HAL**  
open science

# Is it more effective to protect susceptible individuals or isolate infected people to prevent the spread of a SIR-type epidemic?

Mostafa Adimy, Abdennasser Chekroun, Charlotte Dugourd-Camus

## ► To cite this version:

Mostafa Adimy, Abdennasser Chekroun, Charlotte Dugourd-Camus. Is it more effective to protect susceptible individuals or isolate infected people to prevent the spread of a SIR-type epidemic?. *Discrete and Continuous Dynamical Systems - Series B*, 2024. hal-04847754

HAL Id: hal-04847754

<https://inria.hal.science/hal-04847754v1>

Submitted on 19 Dec 2024

**HAL** is a multi-disciplinary open access archive for the deposit and dissemination of scientific research documents, whether they are published or not. The documents may come from teaching and research institutions in France or abroad, or from public or private research centers.

L'archive ouverte pluridisciplinaire **HAL**, est destinée au dépôt et à la diffusion de documents scientifiques de niveau recherche, publiés ou non, émanant des établissements d'enseignement et de recherche français ou étrangers, des laboratoires publics ou privés.



Distributed under a Creative Commons Attribution 4.0 International License

# Is it more effective to protect susceptible individuals or isolate infected people to prevent the spread of a SIR-type epidemic?

Mostafa Adimy<sup>✉1</sup>, Abdennasser Chekroun<sup>✉2</sup>  
and Charlotte Dugourd-Camus<sup>✉1</sup>

<sup>1</sup>Inria, CNRS, Ecole Centrale de Lyon, INSA Lyon, Université Claude Bernard Lyon 1, Université Jean Monnet, ICJ UMR5208, 69603 Villeurbanne, France.

<sup>2</sup>Laboratoire d'Analyse Nonlinéaire et Mathématiques Appliquées, University of Tlemcen, Tlemcen 13000, Algeria.

## Abstract

There are many ways of preventing the spread of an epidemic. One of the most effective is to vaccinate susceptible individuals. Locking down the population or isolating infected individuals are also particularly effective ways of preventing the spread of respiratory infections, especially when no effective vaccine yet exists. The purpose of this work is to compare two approaches used to prevent the spread of an epidemic, namely the protection of susceptible people and the isolation of infected individuals. A classical SIR model is used, with a phase of protection of susceptible population and a phase of isolation of infected individuals. These two phases are temporally limited and are represented by a system of age-structured partial differential equations. By integrating the age-structured system along the characteristics, we reduce the model to a hybrid differential-difference SIR epidemic model with two delays. We determine the basic reproduction number,  $\mathcal{R}_0$ , of this system, and using Lyapunov functionals, we prove that if  $\mathcal{R}_0 \leq 1$ , the disease-free equilibrium is globally attractive and if  $\mathcal{R}_0 > 1$ , the endemic equilibrium is globally attractive. Furthermore, we also prove the uniform weak and strong persistence of the epidemic when  $\mathcal{R}_0 > 1$ . We conclude our work with a comparative numerical study of the efficacy of protecting susceptible individuals versus isolating infected individuals on the spread of the epidemic.

**Keywords:** SIR epidemic model, Age-structured PDE, Delay differential-difference system, Basic reproduction number, Lyapunov functional, Global stability, Uniform weak and strong persistence.

**MSC Classification:** 4D23, 34K17, 34K34, 37N25, 92D30.

## 1 Introduction

The way in which an epidemic spreads is a subject that has already been studied extensively, but is still relevant today. Among the best known are the classic compartmental models of Kermack-McKendric, [25], and the studies of smallpox and malaria done by Bernoulli and Ross, [13, 30]. One of the main questions is how to prevent the disease from spreading. During the Covid-19 epidemic, a number of more or less effective measures were recommended to reduce the spread of the disease: use of mask, social distancing, mobility restrictions, indoor settings closure, lockdown. However, one of the most effective and well-studied approaches is to vaccinate susceptible individuals. From a modeling point of view, it is then possible to simply add a compartment corresponding to the vaccination, [10, 11, 34], or, for a more precise model, to consider an age-structured system, [16, 20]. Some classical applications are influenza or cholera, but recent works also studied the effect

of PrEP on HIV propagation, [8]. In other respects, the recent Covid-19 epidemic has highlighted another way of containing disease transmission: isolation of infected individuals, [35]. Indeed, the isolation of infected individuals is also a particularly effective way to prevent the spread of an epidemic. An even more drastic method is confinement, [14, 33]. In [9, 31], the author study a model in which quarantine, isolation and vaccination are mixed. In summary, the main methods used to control the spread of an epidemic are (preventive) vaccination; isolation: infected people are isolated to prevent them from transmitting the disease; quarantine: people who may have been in contact with the virus are isolated for a certain period of time because they are suspected (but not confirmed) of having contracted the disease. It should be noted that in this case, healthy and unhealthy people are isolated, and healthy people may be quarantined with infected people; and finally confinement: everyone is isolated, including people who have not been in contact with the disease. Here are a few examples where some of these methods have been very useful. Vaccination eradicated smallpox and considerably reduced the incidence and consequences of other diseases such as measles, whooping cough, tuberculosis and even influenza. The plague and cholera are two diseases known to have used quarantine. In the past, this method was widely used in ports when new ships arrived. More recently, during the Covid-19 crisis, some countries, such as China, also applied this method to new arrivals in the country, particularly those arriving by air. Similarly, during this pandemic, lockdown measures were taken by many countries during the highest peaks, followed by isolation measures only.

Nevertheless, a model comparing the impact of protecting susceptible population with that of isolating infected individuals seems to be a novelty. In this paper, we focus on a simple SIR model with a linear force of infection and try to determine the most appropriate approach between protecting susceptible population and isolating infected individuals. We consider an age-structured model in which susceptible individuals can protect themselves for a limited period (as in [1, 3, 6]) and infected individuals can be temporarily isolated. We therefore obtain a model with two different delays, the first corresponding to the duration of the protection period and the second to the duration of the isolation period. In our model, we assume that infected individuals can recover even if they are isolated, and that once they have recovered, they are permanently immune. We also assume that protected susceptible individuals cannot be infected and that isolated infected individuals cannot infect others. We therefore suppose that the new arrivals are all susceptible and that the mortality rates in each compartment may be different.

The system we obtain is a coupling between time-delay differential equations and continuous-time difference equations, see [7, 12, 23, 27, 28]. For our model, two delays appear for the reasons explained above, which is new compared to our previous models. This type of model can be adapted to various biological phenomena in which two states can be distinguished: an active state and an inactive state. The interpretation of the terms "active" and "inactive" may vary from one model to another. For example, in cell division, the active state can be the division phase and the inactive state the resting phase ( $G_0$ -phase), see for instance [2, 4, 7]. In epidemiology, the active state represents the period when individuals are protected, for instance by vaccination or treatment, and the inactive state the period when they are susceptible, see for instance [1, 3, 5]. With a few exceptions, these proposed models can be considered as hyperbolic systems. Furthermore, these equations, which may sometimes seem simple, present considerable theoretical dif-

difficulties. In particular, the existence of two delays introduces additional difficulties. The main difficulties relate to proving the results concerning uniform persistence and global stability. To prove uniform persistence, we reason by the absurd and look for a contradiction as in the paper [19]. On the same subject, in [29], the author studies a structured SI model of infection load, shows in particular the uniform persistence and defines a key function (*cf.*  $g$  in Section 6) to obtain a Lyapunov functional adequate for the proof of global stability. With regard to global stability, we constructed a Lyapunov functional that is well adapted to both disease-free and endemic steady-states.

The first objective of this study is to use a model to compare the impact of protecting susceptible population and isolating infected individuals. We also aim to carry out a complete theoretical study of this new hybrid system, composed of a two-delay differential system and a continuous-time difference system. In Section 2, we give a formulation of the model based on a system of age-structured partial differential equations. In the same section, we reduce the age-structured model to a hybrid differential-difference system with two delays. Section 3 is devoted to discussing the existence of steady-states and establishing the basic reproduction number,  $\mathcal{R}_0$ . Section 4 focuses on the general properties used for persistence and global stability results, which can be found in Sections 5 and 6. Section 5 is devoted to the persistence of the disease when the basic reproduction number is greater than one. We prove uniform weak and strong persistence. In Section 6, we study the global asymptotic stability of the two steady-states, disease-free and endemic. Using appropriate Lyapunov functionals, we obtain the global attractivity of each steady-state. Indeed, we prove that if  $\mathcal{R}_0 \leq 1$ , the disease-free steady-state is globally attractive and if  $\mathcal{R}_0 > 1$ , the endemic steady-state is globally attractive. Finally, we conclude our work in Section 7 with numerical simulations and a general discussion. We carry out a comparative study of the efficacy of protecting susceptible population versus isolating infected individuals on the spread of the epidemic.

## 2 Presentation of the model

Consider that during an epidemic, susceptible individuals can protect themselves (through vaccination, treatment, teleworking, lockdown, etc.) by entering a compartment that protects them from contamination (compartment  $P$ ). Similarly, infected individuals can be isolated (compartment  $Q$ ) to prevent contamination of susceptible individuals. We neglect infections of protected individuals, in compartment  $P$ , and transmission of infection by isolated individuals, in compartment  $Q$ .

The rate of new susceptible individuals is  $\Lambda$ . It includes newborns, immigrants, etc. The force of infection follows the usual law of mass action,  $\beta I$ , with  $\beta > 0$ . Susceptible individuals enter in the protection phase, with a rate  $h$ . During this period, susceptible individuals cannot be infected. After a fixed period of time  $\tau$ , protected individuals can update their protection with a rate  $\alpha \in (0, 1)$ . They become susceptible again at a rate  $1 - \alpha$ . Similarly, infected individuals are isolated at a rate  $k$ , for a fixed period of time  $\tau'$ . At the end of this period, isolation can be renewed at a rate  $\alpha' \in (0, 1)$ . Infected individuals, whether isolated or not, recover at a rate  $\mu$ . They then acquire permanent immunity and are therefore placed in the compartment  $R$  (this compartment is not taken into account in the model). The mortality rates are denoted by  $a_S$ ,  $a_I$ ,  $a_p$  and  $a_q$ . Figure 1 is a representation of the model SIR explained above.

Denote by  $p(t, a)$  and  $q(t, a)$  the densities of protected and isolated populations at time  $t$ , which have spent a time  $a \in (0, \tau)$  and  $a \in (0, \tau')$  in their respective compartments. The total populations of protected and isolated individuals are therefore

$$P(t) = \int_0^\tau p(t, a) da \quad \text{and} \quad Q(t) = \int_0^{\tau'} q(t, a) da. \quad (1)$$

According to the definition of  $p(t, a)$  and  $q(t, a)$ , we have that  $p(t, 0)$  and  $q(t, 0)$  are the populations of protected and isolated individuals starting their protection or isolation phase, whereas  $p(t, \tau)$  and  $q(t, \tau')$  are those at the end of their protection or isolation phase. We then have the following boundary conditions

$$p(t, 0) = hS(t) + \alpha p(t, \tau) \quad \text{and} \quad q(t, 0) = kI(t) + \alpha' q(t, \tau').$$

In addition,  $p(t, a)$  and  $q(t, a)$  satisfy the age-structured partial differential equations

$$\frac{\partial p}{\partial t}(t, a) + \frac{\partial p}{\partial a}(t, a) = -a_p p(t, a) \quad \text{and} \quad \frac{\partial q}{\partial t}(t, a) + \frac{\partial q}{\partial a}(t, a) = -(a_q + \mu)q(t, a).$$

We thus obtain the following epidemic model

$$\left\{ \begin{array}{l} S'(t) = \Lambda - (h + a_S)S(t) - \beta S(t)I(t) + (1 - \alpha)p(t, \tau), \\ I'(t) = -(\mu + k + a_I)I(t) + \beta S(t)I(t) + (1 - \alpha')q(t, \tau'), \\ \frac{\partial p}{\partial t}(t, a) + \frac{\partial p}{\partial a}(t, a) = -a_p p(t, a), \\ \frac{\partial q}{\partial t}(t, a) + \frac{\partial q}{\partial a}(t, a) = -(a_q + \mu)q(t, a), \\ p(t, 0) = hS(t) + \alpha p(t, \tau), \\ q(t, 0) = kI(t) + \alpha' q(t, \tau'), \end{array} \right. \quad (2)$$

with the non-negative initial condition

$$S(0) = S_0, \quad I(0) = I_0, \quad p(0, a) = p_0(a), \quad a \in (0, \tau) \quad \text{and} \quad q(0, a) = q_0(a), \quad a \in (0, \tau'),$$

where  $p_0, q_0$  can be integrable on  $(0, \tau)$  and  $(0, \tau')$ , respectively. We assume that  $p_0, q_0$  are continuous on the intervals  $[0, \tau]$  and  $[0, \tau']$  and satisfy the compatibility conditions

$$p_0(0) = hS_0 + \alpha p_0(\tau) \quad \text{and} \quad q_0(0) = kI_0 + \alpha' q_0(\tau'). \quad (3)$$

We then introduce the following continuous functions

$$\Phi_p(t) = e^{-a_p t} p_0(-t), \quad t \in [-\tau, 0] \quad \text{and} \quad \Phi_q(t) = e^{-(a_q + \mu)t} q_0(-t), \quad t \in [-\tau', 0],$$

which depend only on the initial conditions  $p_0$  and  $q_0$ . We denote by  $u(t)$ , respectively  $v(t)$ , the number of individuals entering the compartment  $P$ , respectively  $Q$ , at time  $t > 0$ ,

$$u(t) := p(t, 0), \quad \text{and} \quad v(t) := q(t, 0).$$

Using the method of characteristics, we obtain that the functions  $p$  and  $q$  are determined, for  $t > 0$ ,  $a \in [0, \tau]$  and  $a \in [0, \tau']$ , respectively, by the functions  $u, v, \Phi_p$

and  $\Phi_q$ ,

$$\begin{aligned} p(t, a) &= e^{-a_p a} \begin{cases} u(t-a), & t > a, \\ \Phi_p(t-a), & 0 < t \leq a, \end{cases} \\ \text{and } q(t, a) &= e^{-(a_q + \mu)a} \begin{cases} v(t-a), & t > a, \\ \Phi_q(t-a), & 0 < t \leq a. \end{cases} \end{aligned} \quad (4)$$

The last two boundary conditions of System (2) become

$$u(t) = \begin{cases} hS(t) + \alpha e^{-a_p \tau} u(t-\tau), & t > 0, \\ \Phi_p(t), & -\tau < t \leq 0, \end{cases} \quad (5)$$

and

$$v(t) = \begin{cases} kI(t) + \alpha' e^{-(a_q + \mu)\tau'} v(t-\tau'), & t > 0, \\ \Phi_q(t), & -\tau' < t \leq 0. \end{cases} \quad (6)$$

The epidemic model (2) is then reduced to the following hybrid system, for  $t > 0$ ,

$$\begin{cases} S'(t) &= \Lambda - (h + a_S)S(t) - \beta S(t)I(t) + (1 - \alpha)e^{-a_p \tau} u(t-\tau), \\ I'(t) &= -(\mu + k + a_I)I(t) + \beta S(t)I(t) + (1 - \alpha')e^{-(a_q + \mu)\tau'} v(t-\tau'), \\ u(t) &= hS(t) + \alpha e^{-a_p \tau} u(t-\tau), \\ v(t) &= kI(t) + \alpha' e^{-(a_q + \mu)\tau'} v(t-\tau'), \end{cases} \quad (7)$$

with the non-negative initial condition

$$S(0) = S_0, \quad I(0) = I_0, \quad u(t) = \Phi_p(t), \quad t \in [-\tau, 0] \quad \text{and} \quad v(t) = \Phi_q(t), \quad t \in [-\tau', 0],$$

where the functions  $\Phi_p \in \mathcal{C}([-\tau, 0], \mathbb{R}^+)$  and  $\Phi_q \in \mathcal{C}([-\tau', 0], \mathbb{R}^+)$  satisfy the compatibility conditions (3). In other words

$$\Phi_p(0) = hS_0 + \alpha e^{-a_p \tau} \Phi_p(-\tau) \quad \text{and} \quad \Phi_q(0) = kI_0 + \alpha' e^{-(a_q + \mu)\tau'} \Phi_q(-\tau'). \quad (8)$$

By solving System (7), we can determine from (4),  $p(t, a)$  and  $q(t, a)$  then from (1), the total populations  $P$  and  $Q$ . In fact, we have

$$P(t) = \begin{cases} \int_0^\tau e^{-a_p a} u(t-a) da, & t \geq \tau, \\ \int_0^t e^{-a_p a} u(t-a) da + \int_t^\tau e^{-a_p a} \Phi_p(t-a) da, & 0 \leq t \leq \tau, \end{cases} \quad (9)$$

and

$$Q(t) = \begin{cases} \int_0^{\tau'} e^{-(a_q + \mu)a} v(t-a) da, & t \geq \tau', \\ \int_0^t e^{-(a_q + \mu)a} v(t-a) da + \int_t^{\tau'} e^{-(a_q + \mu)a} \Phi_q(t-a) da, & 0 \leq t \leq \tau'. \end{cases} \quad (10)$$

In what follows, we focus on the hybrid model (7).

**Proposition 2.1.** *All solutions  $(S, I, u, v)$  of System (7) associated with non-negative initial conditions  $(S_0, I_0, \Phi_p, \Phi_q)$  are non-negative and uniformly eventually bounded. Moreover,  $S$  and  $I$  have a continuous first derivative for all  $t > 0$ , and  $u$  and  $v$  are continuous for all  $t \geq -\tau$  and all  $t \geq -\tau'$ , respectively, if and only if the initial conditions  $(S_0, I_0, \Phi_p, \Phi_q)$  satisfy the compatibility conditions (8).*

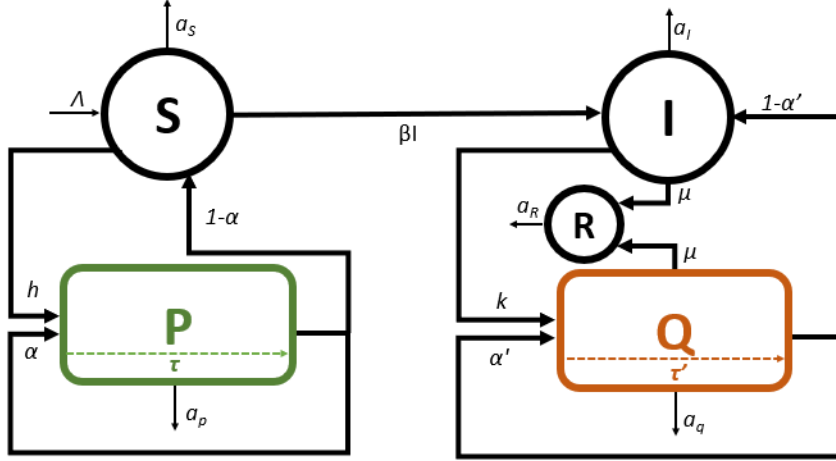

Figure 1: Schematic representation of the SIR model with protection and isolation phases.

*Proof.* Let  $\tau_m := \min(\tau, \tau')$  and  $\tau_M := \max(\tau, \tau')$ . To prove the non-negativity of the solution, we do this first on the intervals  $[0, \tau_m]$  and  $[0, \tau_M]$ , then on each interval  $[k\tau_m, (k+1)\tau_m]$ ,  $[k\tau_M, (k+1)\tau_M]$ , for  $k = 1, 2, \dots$ . To simplify the proof, we can assume that  $\tau = \tau'$ . For  $t \in [0, \tau]$ , we have  $t - \tau \in [-\tau, 0]$ , and the system (7) can be rewritten as follows

$$\begin{cases} S'(t) &= \Lambda - (h + a_S)S(t) - \beta S(t)I(t) + (1 - \alpha)e^{-a_p\tau}\Phi_p(t - \tau), \\ I'(t) &= -(\mu + k + a_I)I(t) + \beta S(t)I(t) + (1 - \alpha')e^{-(a_q + \mu)\tau'}\Phi_q(t - \tau'), \\ u(t) &= hS(t) + \alpha e^{-a_p\tau}\Phi_p(t - \tau), \\ v(t) &= kI(t) + \alpha' e^{-(a_q + \mu)\tau'}\Phi_q(t - \tau'). \end{cases}$$

We then have for  $S(t) = 0$ ,

$$S'(t) = \Lambda - (h + a_S)S(t) + (1 - \alpha)e^{-a_p\tau}\Phi_p(t - \tau) = \Lambda + (1 - \alpha)e^{-a_p\tau}\Phi_p(t - \tau) > 0,$$

and for  $I(t) = 0$ ,

$$I'(t) = \beta S(t)I(t) + (1 - \alpha')e^{-(a_q + \mu)\tau'}\Phi_q(t - \tau') = (1 - \alpha')e^{-(a_q + \mu)\tau'}\Phi_q(t - \tau') > 0.$$

So,  $S(t), I(t) \geq 0$ , for  $t \in [0, \tau]$ . Then,  $u(t) \geq 0$  and  $v(t) \geq 0$  for  $t \in [0, \tau]$ . The same reasoning is applied to the interval  $[\tau, 2\tau]$ , and so on. We conclude that  $S, I, u$  and  $v$  are non-negative on the interval  $[0, +\infty)$ . We now denote by  $N(t)$  the total population at time  $t \geq 0$ , *i.e.*  $N(t) = S(t) + I(t) + P(t) + Q(t)$ . So, we have

$$N'(t) \leq \Lambda - a_N N(t), \quad t > 0,$$

with  $a_N := \min(a_S, a_I + \mu, a_p, a_q + \mu)$ . Then,

$$\limsup_{t \rightarrow +\infty} N(t) \leq \frac{\Lambda}{a_N}.$$

Thus, the solution is uniformly eventually bounded, *i.e.*, there is  $c > 0$  such that  $\limsup_{t \rightarrow +\infty} (S(t) + I(t) + P(t) + Q(t)) < c$ , for all non-negative solutions, see [32]. This means that each sub-population,  $S$ ,  $I$ ,  $u$  and  $v$  is uniformly eventually bounded.

For the regularity of the solution, since we know that  $\Phi_p$  and  $\Phi_q$  are continuous, then we have that  $S'$  and  $I'$  are continuous for all  $t \geq 0$ . Furthermore,  $u$ , respectively  $v$ , is continuous for any  $t \geq -\tau$ , respectively for any  $t \geq -\tau'$ , if and only if the compatibility conditions (8) are satisfied.  $\square$

### 3 Steady-states and basic reproduction number

Our main objective is to study the behavior of System (7). We first investigate the existence of steady-states and determine the basic reproduction number. The steady-states of (7), denoted  $\bar{E} = (\bar{S}, \bar{I}, \bar{u}, \bar{v})$ , are the solutions of the following system

$$\begin{cases} \Lambda - (h + a_S)\bar{S} - \beta\bar{S}\bar{I} + (1 - \alpha)e^{-a_p\tau}\bar{u} &= 0, \\ -(\mu + k + a_I)\bar{I} + \beta\bar{S}\bar{I} + (1 - \alpha')e^{-(a_q+\mu)\tau'}\bar{v} &= 0, \\ (1 - \alpha e^{-a_p\tau})\bar{u} &= h\bar{S}, \\ (1 - \alpha' e^{-(a_q+\mu)\tau'})\bar{v} &= k\bar{I}. \end{cases}$$

The third and fourth equations give

$$\bar{u} = \frac{h}{1 - \alpha e^{-a_p\tau}}\bar{S} \quad \text{and} \quad \bar{v} = \frac{k}{1 - \alpha' e^{-(a_q+\mu)\tau'}}\bar{I}.$$

Then, by substituting  $\bar{u}$  and  $\bar{v}$  in the first two equations, we get

$$\begin{cases} \left[ \beta\bar{I} + \frac{h + a_S - (h + \alpha a_S)e^{-a_p\tau}}{1 - \alpha e^{-a_p\tau}} \right] \bar{S} = \Lambda, \\ \left[ \beta\bar{S} - \frac{k + \mu + a_I - [k + (\mu + a_I)\alpha']e^{-(a_q+\mu)\tau'}}{1 - \alpha' e^{-(a_q+\mu)\tau'}} \right] \bar{I} = 0, \\ \bar{u} = \frac{h}{1 - \alpha e^{-a_p\tau}}\bar{S}, \\ \bar{v} = \frac{k}{1 - \alpha' e^{-(a_q+\mu)\tau'}}\bar{I}. \end{cases} \quad (11)$$

The disease-free steady-state that always exists is given by

$$E^0 := (S^0, 0, u^0, 0),$$

with

$$S^0 = \frac{\Lambda(1 - \alpha e^{-a_p\tau})}{h + a_S - (h + \alpha a_S)e^{-a_p\tau}} \quad \text{and} \quad u^0 = \frac{h}{1 - \alpha e^{-a_p\tau}}S^0.$$

Denote an endemic equilibrium by  $E^* = (S^*, I^*, u^*, v^*)$ , with  $I^* > 0$ . The second and third equations imply

$$S^* = \frac{k + \mu + a_I - [k + (\mu + a_I)\alpha']e^{-(a_q+\mu)\tau'}}{\beta(1 - \alpha' e^{-(a_q+\mu)\tau'})} \quad \text{and} \quad u^* = \frac{h}{1 - \alpha e^{-a_p\tau}}S^*.$$



Then, we get

$$I^* = \frac{\Lambda}{\beta} \left[ \frac{1}{S^*} - \frac{1}{S^0} \right] \quad \text{and} \quad v^* = \frac{k}{1 - \alpha' e^{-(a_q + \mu)\tau'}} I^*.$$

The condition of existence of the endemic steady-state is

$$\mathcal{R}_0 := \frac{S^0}{S^*} = \frac{\beta \left( 1 - \alpha' e^{-(a_q + \mu)\tau'} \right)}{k + \mu + a_I - [k + (\mu + a_I)\alpha'] e^{-(a_q + \mu)\tau'}} \times \frac{\Lambda(1 - \alpha e^{-a_p\tau})}{h + a_S - (h + \alpha a_S) e^{-a_p\tau}} > 1.$$

We have therefore proved the following theorem.

**Theorem 3.1.** *The unique endemic steady-state  $E^*$  exists if and only if  $\mathcal{R}_0 > 1$ . The disease-free steady-state  $E^0$  always exists.*

**Remark 3.2.** *Using the equations (9) and (10), we deduce the total protected and isolated stationary populations,*

$$\bar{P} = \frac{1 - e^{-a_p\tau}}{a_p} \bar{u} \quad \text{and} \quad \bar{Q} = \frac{1 - e^{-(a_q + \mu)\tau'}}{a_q + \mu} \bar{v},$$

with  $\bar{u}$  and  $\bar{v}$  given by (11).

It is interesting to study  $\mathcal{R}_0 := S^0/S^*$  as a function of the parameters of the system (7), and in particular the two parameters  $\tau$  and  $\tau'$ . First, we can easily prove the following result.

**Proposition 3.3.** *The function  $\tau \mapsto S^0(\tau)$  is decreasing on  $\mathbb{R}^+$  and the function  $\tau' \mapsto S^*(\tau')$  is increasing on  $\mathbb{R}^+$ , with*

$$S_0^0 := S^0(0) = \frac{\Lambda}{a_S}, \quad S_\infty^0 := \lim_{\tau \rightarrow +\infty} S^0(\tau) = \frac{\Lambda}{h + a_S}$$

and

$$S_0^* := S^*(0) = \frac{\mu + a_I}{\beta}, \quad S_\infty^* := \lim_{\tau' \rightarrow +\infty} S^*(\tau') = \frac{k + \mu + a_I}{\beta}.$$

*Proof.* We have

$$\begin{aligned} \frac{\partial S^0}{\partial \tau}(\tau) &= \frac{\Lambda a_p h (\alpha - 1) e^{-a_p\tau}}{(h + a_S - (h + \alpha a_S) e^{-a_p\tau})^2} < 0 \\ \text{and} \quad \frac{\partial S^*}{\partial \tau'}(\tau') &= \frac{\beta k (a_q + \mu) (1 - \alpha') e^{-(a_q + \mu)\tau'}}{(\beta (1 - \alpha' e^{-(a_q + \mu)\tau'}))^2} > 0. \end{aligned}$$

□

Figures 2(a)-(a') and (b)-(b') represent the functions  $\tau \mapsto S^0(\tau)$  and  $\tau' \mapsto S^*(\tau')$ . Using Proposition 3.3, we define the ranges of the functions  $\tau \mapsto S^0(\tau)$  and  $\tau' \mapsto S^*(\tau')$  as follows

$$\mathbb{S}^0 := (S_\infty^0, S_0^0] \quad \text{and} \quad \mathbb{S}^* := [S_0^*, S_\infty^*), \quad \text{with} \quad S_\infty^0 < S_0^0 \quad \text{and} \quad S_0^* < S_\infty^*.$$

The next objective is to find the pair  $(\tau, \tau')$  for which  $\mathcal{R}_0(\tau, \tau') = 1$ , *i.e.* for which  $S^0(\tau) = S^*(\tau')$ . This depends on the intersection between the two intervals  $\mathbb{S}^0$  and  $\mathbb{S}^*$ . We define the four limits  $\tau_0, \tau'_0, \tau_\infty$  and  $\tau'_\infty$ , when they exist, by

$$\mathcal{R}_0(\tau_0, 0) = \mathcal{R}_0(\tau_\infty, +\infty) = \mathcal{R}_0(0, \tau'_0) = \mathcal{R}_0(+\infty, \tau'_\infty) = 1.$$

In fact, they are given explicitly by

$$\left\{ \begin{array}{ll} \tau_0 = \frac{1}{a_p} \ln \left( \frac{(h + a_S \alpha)(\mu + a_I) - \beta \Lambda \alpha}{(h + a_S)(\mu + a_I) - \beta \Lambda} \right), & \text{for } S_0^* \in \mathbb{S}^0, \\ \tau_\infty = \frac{1}{a_p} \ln \left( \frac{(h + a_S \alpha)(k + \mu + a_I) - \beta \Lambda \alpha}{(h + a_S)(k + \mu + a_I) - \beta \Lambda} \right), & \text{for } S_\infty^* \in \mathbb{S}^0, \\ \tau'_0 = \frac{1}{a_q + \mu} \ln \left( \frac{a_S(k + (\mu + a_I)\alpha') - \beta \Lambda \alpha'}{a_S(k + \mu + a_I) - \beta \Lambda} \right), & \text{for } S_0^0 \in \mathbb{S}^*, \\ \tau'_\infty = \frac{1}{a_q + \mu} \ln \left( \frac{(h + a_S)(k + (\mu + a_I)\alpha') - \beta \Lambda \alpha'}{(h + a_S)(k + \mu + a_I) - \beta \Lambda} \right), & \text{for } S_\infty^0 \in \mathbb{S}^*. \end{array} \right.$$

We then obtain the following result.

**Lemma 3.4.** (1) Suppose that  $S_0^0 < S_0^*$ . Then,  $\mathcal{R}_0(\tau, \tau') < 1$ , for all  $\tau, \tau' \geq 0$ .

(2) Suppose that  $S_\infty^* < S_\infty^0$ . Then,  $\mathcal{R}_0(\tau, \tau') > 1$ , for all  $\tau, \tau' \geq 0$ .

(3) Suppose that  $S_0^* < S_\infty^0 < S_0^0 < S_\infty^*$ , which is equivalent to the assumption that  $\mathbb{S}^0 \subset \mathbb{S}^*$ . Then, for all  $\tau \in \mathbb{R}^+$ , there exists a unique  $\bar{\tau}'(\tau) \in [\tau'_0, \tau'_\infty)$  such that  $\mathcal{R}_0(\tau, \bar{\tau}'(\tau)) = 1$ . Furthermore, if  $\tau' < \bar{\tau}'(\tau)$ , we have  $\mathcal{R}_0(\tau, \tau') > 1$  and if  $\tau' > \bar{\tau}'(\tau)$ , we have  $\mathcal{R}_0(\tau, \tau') < 1$ .

(4) Suppose that  $S_\infty^0 < S_0^* < S_\infty^* < S_0^0$ , which is equivalent to the assumption that  $\mathbb{S}^* \subset \mathbb{S}^0$ . Then, for all  $\tau' \in \mathbb{R}^+$ , there exists a unique  $\bar{\tau}(\tau') \in [\tau_0, \tau_\infty)$  such that  $\mathcal{R}_0(\bar{\tau}(\tau'), \tau') = 1$ . Furthermore, if  $\tau < \bar{\tau}(\tau')$ , we have  $\mathcal{R}_0(\tau, \tau') > 1$  and if  $\tau > \bar{\tau}(\tau')$ , we have  $\mathcal{R}_0(\tau, \tau') < 1$ .

(5) Suppose that  $S_\infty^0 < S_0^* < S_0^0 < S_\infty^*$ , which is equivalent to the assumption that  $\mathbb{S}^* \cap \mathbb{S}^0 = [S_0^*, S_0^0]$ . Then, for all  $\tau \in [0, \tau_0]$ , there exists a unique  $\bar{\tau}'(\tau) \in [0, \tau'_0]$  such that  $\mathcal{R}_0(\tau, \bar{\tau}'(\tau)) = 1$ . Furthermore, if  $\tau' < \bar{\tau}'(\tau)$ , we have  $\mathcal{R}_0(\tau, \tau') > 1$  and if  $\tau' > \bar{\tau}'(\tau)$ , we have  $\mathcal{R}_0(\tau, \tau') < 1$ .

(6) Suppose that  $S_0^* < S_\infty^0 < S_\infty^* < S_0^0$ , which is equivalent to the assumption that  $\mathbb{S}^* \cap \mathbb{S}^0 = (S_\infty^0, S_\infty^*)$ . Then, for all  $\tau > \tau_\infty$ , there exists a unique  $\bar{\tau}'(\tau) > \tau'_\infty$  such that  $\mathcal{R}_0(\tau, \bar{\tau}'(\tau)) = 1$ . Furthermore, if  $\tau' < \bar{\tau}'(\tau)$ , we have  $\mathcal{R}_0(\tau, \tau') > 1$  and if  $\tau' > \bar{\tau}'(\tau)$ , we have  $\mathcal{R}_0(\tau, \tau') < 1$ .

*Proof.* The proof is simple, and therefore left to the reader.  $\square$

## 4 Fundamental properties of nonhomogeneous functional difference equation

In this section, we present some fundamental properties of the nonhomogeneous functional difference equation that will be used in the next sections. We consider

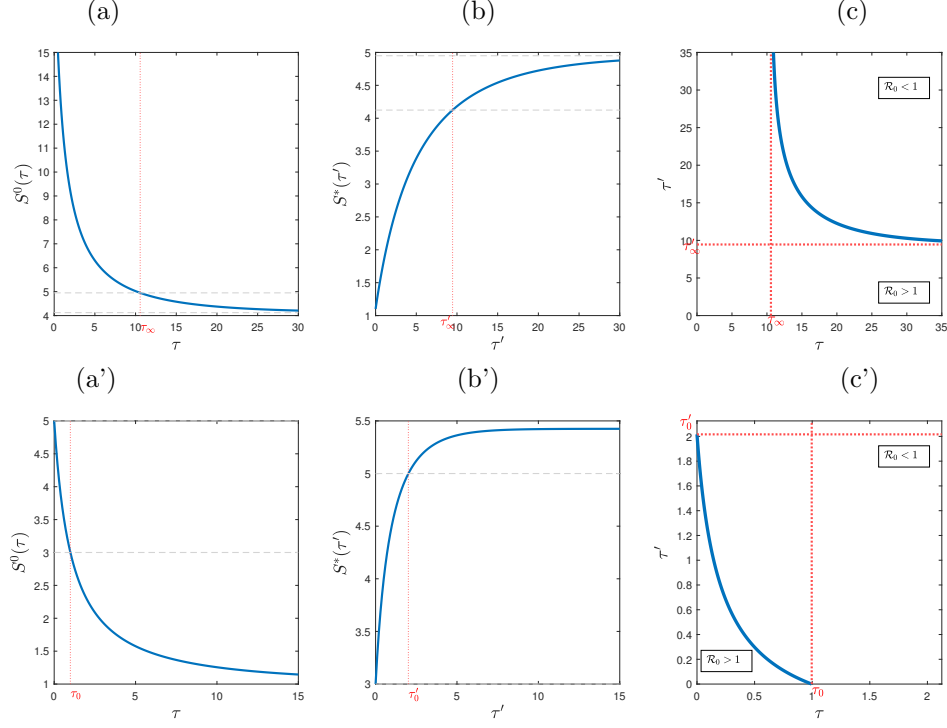

Figure 2: Here we first consider the situation  $S_0^* < S_\infty^0 < S_\infty^* < S_0^0$ , which corresponds to item (6) of Lemma 3.4 (sub-figures (a), (b) and (c)), and then the situation  $S_\infty^0 < S_0^* < S_0^0 < S_\infty^*$ , corresponding to item (5) (sub-figures (a'), (b') and (c')). (a)-(a') The curve of  $\tau \mapsto S^0(\tau)$ . (b)-(b') The curve of  $\tau' \mapsto S^*(\tau')$ . (c)-(c') The blue curve indicates the separation,  $S^*(\tau') = S^0(\tau)$ , between the areas where  $\mathcal{R}_0(\tau, \tau') < 1$  and  $\mathcal{R}_0(\tau, \tau') > 1$ . The red dotted lines indicate the threshold values of  $\tau_\infty$  and  $\tau'_\infty$  or  $\tau_0$  and  $\tau'_0$ . The common parameter values are  $\mu = 0.5$ ,  $\beta = 0.2$ ,  $a_S = 0.1$ ,  $a_I = 0.1$ ,  $a_p = 0.1$ ,  $a_q = 0.1$ ,  $h = 0.385$ . For the first situation (a-c) we have  $\Lambda = 2$ ,  $k = 0.385$ ,  $\alpha = 0.95$ ,  $\alpha' = 0.05$  and for the second one (a'-c')  $\Lambda = 0.5$ ,  $k = 0.485$ ,  $\alpha = 0.5$ ,  $\alpha' = 0.5$ .

the following general problem

$$u(t) = \begin{cases} \Psi(t) + \xi u(t - \tau), & t > 0, \\ \phi(t), & -\tau \leq t \leq 0, \end{cases} \quad (12)$$

with  $0 < \xi < 1$  and  $\phi \in \mathcal{C}([-\tau, 0], \mathbb{R})$  satisfying the compatibility condition. The two systems (5) and (6) are particular cases of System (12). We also assume in all this section, that the function  $\Psi : [0, +\infty) \rightarrow \mathbb{R}$  is continuous. We have the following classical result.

**Lemma 4.1.** *Suppose that the function  $\Psi$  satisfies*

$$\lim_{t \rightarrow +\infty} \Psi(t) = 0.$$

*Then, the solution  $u$  of the system (12) satisfies*

$$\lim_{t \rightarrow +\infty} u(t) = 0.$$

*Proof.* The first equation of (12) can be rewritten

$$D(u_t) = \Psi(t),$$

where the operator  $D : \mathcal{C}([-\tau, 0], \mathbb{R}) \rightarrow \mathbb{R}$  is defined by  $D(\psi) := \psi(0) - \xi\psi(-\tau)$ , with  $\psi \in \mathcal{C}([-\tau, 0], \mathbb{R})$ ,  $0 < \xi < 1$  and the function  $u_t$ , with  $t \geq 0$ , is defined by  $u_t(s) = u(t + s)$ , for  $-\tau \leq s \leq 0$ . As  $|\xi| < 1$ ,  $D$  is uniformly stable, see Definition 3.1, p 275 of [24]. Then, the result comes from Lemma 3.5 of [18].  $\square$

Let  $(t_n)_{n=0}^{+\infty}$  be a non-decreasing sequence such that  $t_0 \geq \tau$  and  $\lim_{n \rightarrow +\infty} t_n = +\infty$ . We define the sequence of functions  $(\Psi_n)_{n=0}^{+\infty}$  which are elements of  $\mathcal{C}([-\tau, 0], \mathbb{R})$ , by

$$\Psi_n(\theta) = \Psi(t_n + \theta), \quad n \geq 0 \text{ and } \theta \in [-\tau, 0].$$

**Lemma 4.2.** *Suppose that the function  $\Psi$  is uniformly continuous and bounded. Then, there exists a subsequence of  $(\Psi_n)_{n=0}^{+\infty}$  that converges in the Banach space  $\mathcal{C}([-\tau, 0], \mathbb{R})$ : there exists  $\bar{\Psi} \in \mathcal{C}([-\tau, 0], \mathbb{R})$  such that  $\lim_{n \rightarrow +\infty} \Psi_n = \bar{\Psi}$  uniformly.*

*Proof.* It is clear that the sequence  $(\Psi_n)_{n=0}^{+\infty}$  is well defined, uniformly bounded and equicontinuous on the space  $\mathcal{C}([-\tau, 0], \mathbb{R})$ . The result follows immediately from the theorem of Ascoli-Arzelà.  $\square$

We now define the sequence  $(u_n)_{n=0}^{+\infty}$  of elements of  $\mathcal{C}([-\tau, 0], \mathbb{R})$ , by

$$u_n(\theta) = u(t_n + \theta), \quad n \geq 0 \text{ and } \theta \in [-\tau, 0],$$

where  $(t_n)_{n=0}^{+\infty}$  is the subsequence obtained in the previous lemma and  $u$  is the solution of (12).

**Lemma 4.3.** *Suppose that the function  $\Psi$  is uniformly continuous and bounded. Then, there exists a subsequence of  $(u_n)_{n=0}^{+\infty}$  that converges in the Banach space  $\mathcal{C}([-\tau, 0], \mathbb{R})$ : there exists  $\bar{u} \in \mathcal{C}([-\tau, 0], \mathbb{R})$  such that  $\lim_{n \rightarrow +\infty} u_n = \bar{u}$  uniformly.*

*Proof.* It is clear that the sequence  $(u_n)_{n=0}^{+\infty}$  is well defined and uniformly bounded on the space  $\mathcal{C}([-\tau, 0], \mathbb{R})$ . We now want to prove that this sequence is equicontinuous. Let  $N_n = \lfloor \frac{t_n}{\tau} \rfloor$  be the integer part of  $\frac{t_n}{\tau}$ , with  $t_0 \geq \tau$ . We obtain, for  $\theta, \theta' \in [-\tau, 0]$ , the inequality

$$\begin{aligned} |u_n(\theta) - u_n(\theta')| &= |u(t_n + \theta) - u(t_n + \theta')|, \\ &\leq |\Psi(t_n + \theta) - \Psi(t_n + \theta')| + \xi |u(t_n + \theta - \tau) - u(t_n + \theta' - \tau)|, \\ &\vdots \\ &\leq \sum_{j=0}^{N_n-1} \xi^j |\Psi(t_n + \theta - j\tau) - \Psi(t_n + \theta' - j\tau)| \\ &\quad + \xi^{N_n} |u(t_n + \theta - N_n\tau) - u(t_n + \theta' - N_n\tau)|. \end{aligned}$$

Then, for all  $1 \leq j \leq N_n - 1$  and  $\theta \in [-\tau, 0]$ , we have

$$t_n + \theta - j\tau \geq 0 \quad \text{and} \quad -\tau \leq t_n + \theta - N_n\tau \leq \tau.$$

Let us consider the function  $\bar{\phi}$  defined on  $[-\tau, \tau]$  by

$$\bar{\phi}(t) = \begin{cases} \Psi(t) + \xi \bar{\phi}(t - \tau), & t \in [0, \tau], \\ \phi(t), & t \in [-\tau, 0]. \end{cases}$$

Using the compatibility condition, we can see that the real function  $\bar{\phi}$  is uniformly continuous on the interval  $[-\tau, \tau]$ . Let  $\varepsilon > 0$  fixed. As the function  $\Psi : [0, +\infty) \rightarrow \mathbb{R}$  is uniformly continuous, then for all  $\tilde{\varepsilon} > 0$  there exists  $\delta > 0$  ( $\delta$  may depend on  $\tilde{\varepsilon}$ , but not on  $\theta, \theta'$  or  $n$ ) such that

$$|\Psi(t_n + \theta - j\tau) - \Psi(t_n + \theta' - j\tau)| < \tilde{\varepsilon},$$

whenever

$$|\theta - \theta'| = |(t_n + \theta - j\tau) - (t_n + \theta' - j\tau)| < \delta.$$

Therefore, we have this inequality for  $\tilde{\varepsilon} = \frac{\varepsilon(1-\xi)}{2}$ . Similarly, using the uniform continuity of  $\bar{\phi}$ , we have

$$|u(t_n + \theta - N_n\tau) - u(t_n + \theta' - N_n\tau)| = |\bar{\phi}(t_n + \theta - N_n\tau) - \bar{\phi}(t_n + \theta' - N_n\tau)| < \frac{\varepsilon}{2},$$

whenever

$$|\theta - \theta'| = |(t_n + \theta - N_n\tau) - (t_n + \theta' - N_n\tau)| < \delta.$$

We conclude that

$$|u_n(\theta) - u_n(\theta')| < \frac{\varepsilon(1-\xi)}{2} \left( \sum_{j=0}^{N_n-1} \xi^j \right) + \frac{\varepsilon}{2} < \varepsilon,$$

whenever

$$|\theta - \theta'| < \delta.$$

The result follows immediately from the theorem of Ascoli-Arzelà.  $\square$

**Corollary 4.4.** *Under the same conditions as Lemma 4.3, suppose that*

$$\lim_{n \rightarrow +\infty} \Psi(t_n) = L \text{ exists.}$$

*Then, the function  $\bar{u}$  given by Lemma 4.3 satisfies*

$$\bar{u}(0) = L + \xi \bar{u}(-\tau).$$

*Proof.* The result follows immediately from the limit of the expression

$$u_n(0) = \Psi(t_n) + \xi u_n(-\tau).$$

$\square$

The following lemma will be particularly used to prove the global stability of the two steady-states.

**Lemma 4.5.** • *Let  $\chi : [0, +\infty) \rightarrow \mathbb{R}$  be a uniformly continuous function such that*

$$\lim_{t \rightarrow +\infty} \int_0^t \chi(s) ds$$

*exists and is finite. Then,*

$$\lim_{t \rightarrow +\infty} \chi(t) = 0.$$

- Let  $V : [0, +\infty) \rightarrow [0, +\infty)$  be a continuously differential function and  $\chi : [0, +\infty) \rightarrow [0, +\infty)$  a uniformly continuous function such that, there exists a positive constant  $\nu$  so that

$$V'(t) \leq -\nu\chi(t), \quad t > 0.$$

Then,

$$\lim_{t \rightarrow +\infty} \chi(t) = 0.$$

*Proof.* The first assertion of Lemma 4.5 is in fact a version of Barbalat's lemma (see lemma 8.2, page 323 of [26]). For the second statement, we start by integrating the two sides of  $V'(t) \leq -\nu\chi(t)$ , which gives us

$$\int_0^t \chi(s) ds \leq \frac{1}{\nu} (V(0) - V(t)). \quad (13)$$

On the other hand, the function  $V$  is non-negative and non-increasing. We then have

$$\lim_{t \rightarrow +\infty} V(t) = \inf_{s \geq 0} V(s) =: \underline{V} \geq 0.$$

This implies that

$$\lim_{t \rightarrow +\infty} \int_0^t \chi(s) ds \leq \frac{1}{\nu} [V(0) - \underline{V}].$$

Clearly, such a limit exists, and by definition  $\chi$  is uniformly continuous. We can therefore apply the first assertion of this lemma to obtain that

$$\lim_{t \rightarrow +\infty} \chi(t) = 0.$$

□

## 5 Uniform weak and uniform strong persistence

We suppose in this section that  $\mathcal{R}_0 > 1$ . We examine the uniform weak and strong persistence of the disease, which also shows the instability of the disease-free equilibrium  $E^0$ . We are in the general situation where the limit, as  $t \rightarrow +\infty$ , of the solutions of System (7) may not exist. For more details on the notion of persistence, see [21, 22, 32].

**Theorem 5.1.** *Suppose that  $\mathcal{R}_0 > 1$ . Then the disease is uniformly weakly persistent, i.e. there exists  $\epsilon > 0$ , such that for any non-negative initial condition  $(S_0, I_0, \Phi_p, \Phi_q)$ , with  $I_0 > 0$ , the solution  $(S, I, u, v)$  of System (7), satisfies*

$$\limsup_{t \rightarrow +\infty} I(t) > \epsilon.$$

*Proof.* We assume by contradiction that for all  $\epsilon > 0$ , there exists  $(S_0, I_0, \Phi_p, \Phi_q)$ , which may depend on  $\epsilon$ , such that  $\limsup_{t \rightarrow +\infty} I(t) \leq \epsilon$ . Therefore, there exists  $T_\epsilon > 0$ , such that  $I(t) \leq \epsilon$ , for all  $t \geq T_\epsilon$ . We deduce from (7) that, for all  $t \geq T_\epsilon$ , we have

$$\begin{cases} S'(t) & \geq \Lambda - (h + a_S)S(t) - \beta\epsilon S(t) + (1 - \alpha)e^{-a_p\tau}u(t - \tau), \\ u(t) & = hS(t) + \alpha e^{-a_p\tau}u(t - \tau). \end{cases}$$

The advantage of this new system is that it is independent of infected compartments  $I$  and  $v$ . The aim is to use it as a comparison system with the system (7). Consider the system

$$\begin{cases} S_\epsilon^+(t) &= \Lambda - (h + a_S)S_\epsilon^+(t) - \beta\epsilon S_\epsilon^+(t) + (1 - \alpha)e^{-a_p\tau}u_\epsilon^+(t - \tau), \\ u_\epsilon^+(t) &= hS_\epsilon^+(t) + \alpha e^{-a_p\tau}u_\epsilon^+(t - \tau), \end{cases} \quad (14)$$

with the initial condition (the same as for System (7))

$$\begin{cases} S_\epsilon^+(0) &= S_0, \\ u_\epsilon^+(s) &= \Phi_p(s), \quad \text{for } s \in [-\tau, 0]. \end{cases}$$

We have the following result.

**Lemma 5.2.** *System (14) has a unique steady-state*

$$(S_\epsilon^0, u_\epsilon^0) = \left( \frac{\Lambda(1 - \alpha e^{-a_p\tau})}{h + a_S - (h + \alpha a_S)e^{-a_p\tau} + \beta\epsilon(1 - \alpha e^{-a_p\tau})}, \frac{hS_\epsilon^0}{1 - \alpha e^{-a_p\tau}} \right),$$

which is globally asymptotically stable.

*Proof.* The proof is similar to that of Theorem 8.1 of [3].  $\square$

For  $\epsilon > 0$ , we define the expression

$$\mathcal{K}^\epsilon := \frac{S_\epsilon^0}{S^*}.$$

Notice that  $\mathcal{K}^0 = \mathcal{R}_0 > 1$  and  $S^0 > S_\epsilon^0 > 0$ . Therefore, for  $\epsilon > 0$  small enough, we have

$$\mathcal{R}_0 > \mathcal{K}^\epsilon > 1. \quad (15)$$

We set  $\epsilon > 0$  so that (15) is satisfied and define, for  $0 < \tilde{\epsilon} < S_\epsilon^0$  small enough, the expression

$$\mathcal{K}^{\epsilon, \tilde{\epsilon}} := \frac{S_\epsilon^0 - \tilde{\epsilon}}{S^*} > 1.$$

Then, we have

$$\mathcal{R}_0 > \mathcal{K}^\epsilon > \mathcal{K}^{\epsilon, \tilde{\epsilon}} > 1.$$

Based on the principle of comparison, we know that  $S(t) \geq S_\epsilon^+(t)$ , for all  $t \geq T_\epsilon$ . Moreover, Lemma 5.2 implies that  $\lim_{t \rightarrow \infty} S_\epsilon^+(t) = S_\epsilon^0$ . Then, for  $\tilde{\epsilon} > 0$  small enough we can choose  $T_{\tilde{\epsilon}} \geq T_\epsilon$ , such that for all  $t \geq T_{\tilde{\epsilon}}$ ,  $S_\epsilon^+(t) > S_\epsilon^0 - \tilde{\epsilon}$ . In short, we proved that

$$S(t) \geq S_\epsilon^+(t) > S_\epsilon^0 - \tilde{\epsilon} > S^*, \quad \text{for all } t \geq T_{\tilde{\epsilon}}.$$

We now define, for  $\xi > 0$ ,

$$\mathcal{K}^{\epsilon, \tilde{\epsilon}, \xi} := \frac{\beta \left( 1 - \alpha' e^{-(\xi + a_q + \mu)\tau'} \right)}{k + \xi + \mu + a_I - [k + (\xi + \mu + a_I)\alpha'] e^{-(\xi + a_q + \mu)\tau'}} \times (S_\epsilon^0 - \tilde{\epsilon}).$$

Notice that

$$\frac{\partial}{\partial \xi} \mathcal{K}^{\epsilon, \tilde{\epsilon}, \xi} = \frac{\beta \left( k\tau' e^{-(\xi + a_q + \mu)\tau'} (\alpha' - 1) - (1 - \alpha' e^{-(\xi + a_q + \mu)\tau'})^2 \right)}{(k + \xi + \mu + a_I - [k + (\xi + \mu + a_I)\alpha'] e^{-(\xi + a_q + \mu)\tau'})^2} \times (S_\epsilon^0 - \tilde{\epsilon}) < 0,$$

and  $\mathcal{K}^{\epsilon, \bar{\epsilon}, 0} = \mathcal{K}^{\epsilon, \bar{\epsilon}}$ . Then, we can choose  $\xi > 0$  small enough such that

$$\mathcal{R}_0 > \mathcal{K}^\epsilon > \mathcal{K}^{\epsilon, \bar{\epsilon}} > \mathcal{K}^{\epsilon, \bar{\epsilon}, \xi} > 1.$$

Now we can establish the contradiction. Indeed, we multiply the equation of  $I(t)$  in System (7) by  $e^{-\xi t}$  and integrate it between  $T_{\bar{\epsilon}}$  to  $+\infty$ ,

$$\begin{aligned} \int_{T_{\bar{\epsilon}}}^{+\infty} e^{-\xi t} I'(t) dt &= \int_{T_{\bar{\epsilon}}}^{+\infty} [-(k + \mu + a_I) + \beta S(t)] e^{-\xi t} I(t) dt \\ &\quad + (1 - \alpha') e^{-(a_q + \mu)\tau'} \int_{T_{\bar{\epsilon}}}^{+\infty} e^{-\xi t} v(t - \tau') dt. \end{aligned}$$

Recall that we have the equality

$$v(t) = kI(t) + \alpha' e^{-(a_q + \mu)\tau'} v(t - \tau'). \quad (16)$$

It can be rewritten as follows

$$v(t - \tau') = \frac{e^{(a_q + \mu)\tau'}}{\alpha'} (v(t) - kI(t)).$$

This gives

$$\begin{aligned} \int_{T_{\bar{\epsilon}}}^{+\infty} e^{-\xi t} I'(t) dt &= \int_{T_{\bar{\epsilon}}}^{+\infty} \left[ -\left(\frac{k}{\alpha'} + \mu + a_I\right) + \beta S(t) \right] e^{-\xi t} I(t) dt \\ &\quad + \frac{1 - \alpha'}{\alpha'} \int_{T_{\bar{\epsilon}}}^{+\infty} e^{-\xi t} v(t) dt. \end{aligned} \quad (17)$$

In addition, by integrating Equation (16) and using the change of variable  $s := t - \tau'$ , we obtain

$$\begin{aligned} \int_{T_{\bar{\epsilon}}}^{+\infty} e^{-\xi t} v(t) dt &= k \int_{T_{\bar{\epsilon}}}^{+\infty} e^{-\xi t} I(t) dt + \alpha' e^{-(a_q + \mu)\tau'} \int_{T_{\bar{\epsilon}}}^{+\infty} e^{-\xi t} v(t - \tau') dt, \\ &= k \int_{T_{\bar{\epsilon}}}^{+\infty} e^{-\xi t} I(t) dt + \alpha' e^{-(a_q + \mu)\tau'} \int_{T_{\bar{\epsilon}} - \tau'}^{+\infty} e^{-\xi(s + \tau')} v(s) ds, \\ &\geq k \int_{T_{\bar{\epsilon}}}^{+\infty} e^{-\xi t} I(t) dt + \alpha' e^{-(\xi + a_q + \mu)\tau'} \int_{T_{\bar{\epsilon}}}^{+\infty} e^{-\xi s} v(s) ds. \end{aligned}$$

So, this gives the following comparison

$$\int_{T_{\bar{\epsilon}}}^{+\infty} e^{-\xi t} v(t) dt \geq \frac{1}{1 - \alpha' e^{-(\xi + a_q + \mu)\tau'}} k \int_{T_{\bar{\epsilon}}}^{+\infty} e^{-\xi t} I(t) dt.$$

We substitute this last inequality in (17) and rearrange the terms to obtain

$$\begin{aligned} &\int_{T_{\bar{\epsilon}}}^{+\infty} e^{-\xi t} I'(t) dt \\ &\geq \int_{T_{\bar{\epsilon}}}^{+\infty} \left[ -\left( k \left( \frac{(1 - e^{-(\xi + a_q + \mu)\tau'})}{1 - \alpha' e^{-(\xi + a_q + \mu)\tau'}} \right) + \mu + a_I \right) + \beta S(t) \right] e^{-\xi t} I(t) dt. \end{aligned}$$



Integrating it by parts, we obtain

$$\begin{aligned} & -e^{-\xi T_{\tilde{\epsilon}}} I(T_{\tilde{\epsilon}}) - \int_{T_{\tilde{\epsilon}}}^{+\infty} -\xi e^{-\xi t} I(t) dt \\ & \geq \int_{T_{\tilde{\epsilon}}}^{+\infty} \left[ - \left( k \frac{(1 - e^{-(\xi+a_q+\mu)\tau'})}{1 - \alpha' e^{-(\xi+a_q+\mu)\tau'}} + \mu + a_I \right) + \beta S(t) \right] e^{-\xi t} I(t) dt. \end{aligned}$$

Finally, using the fact that  $S(t) > S_{\tilde{\epsilon}}^0 - \tilde{\epsilon}$  for  $t > T_{\tilde{\epsilon}}$ , and rearranging the terms, we get

$$\begin{aligned} & -e^{-\xi T_{\tilde{\epsilon}}} I(T_{\tilde{\epsilon}}) \\ & > \left[ -\xi - \left( k \frac{(1 - e^{-(\xi+a_q+\mu)\tau'})}{1 - \alpha' e^{-(\xi+a_q+\mu)\tau'}} + \mu + a_I \right) + \beta(S_{\tilde{\epsilon}}^0 - \tilde{\epsilon}) \right] \int_{T_{\tilde{\epsilon}}}^{+\infty} e^{-\xi t} I(t) dt. \end{aligned}$$

Since  $\mathcal{K}^{\epsilon, \tilde{\epsilon}, \xi} > 1$ , the right-hand term satisfies

$$\left[ -\xi - \left( k \frac{(1 - e^{-(\xi+a_q+\mu)\tau'})}{1 - \alpha' e^{-(\xi+a_q+\mu)\tau'}} + \mu + a_I \right) + \beta(S_{\tilde{\epsilon}}^0 - \tilde{\epsilon}) \right] \int_{T_{\tilde{\epsilon}}}^{+\infty} e^{-\xi t} I(t) dt > 0.$$

This is in contradiction with

$$-e^{-\xi T_{\tilde{\epsilon}}} I(T_{\tilde{\epsilon}}) \leq 0.$$

We conclude that there exists  $\epsilon > 0$ , such that for any non-negative initial condition  $(S_0, I_0, \Phi_p, \Phi_q)$ , with  $I_0 > 0$ , we have

$$\limsup_{t \rightarrow +\infty} I(t) > \epsilon.$$

Then, the uniform weak persistence is proved.  $\square$

In fact, for the system (7), the uniform weak persistence implies the uniform strong persistence. This is shown by the following result.

**Theorem 5.3.** *Assume that  $\mathcal{R}_0 > 1$ . Then, the disease is uniformly strongly persistent, i.e. there exists  $0 < \epsilon' \leq \epsilon$ , with  $\epsilon$  defined in Theorem 5.1, such that for any initial condition  $(S_0, I_0, \Phi_p, \Phi_q)$ , with  $I_0 > 0$ , the solution  $(S, I, u, v)$  of System (7), satisfies*

$$\liminf_{t \rightarrow +\infty} I(t) > \epsilon'.$$

*Proof.* Let  $(S, I, u, v)$  be the solution associated with the initial condition  $(S_0, I_0, \Phi_p, \Phi_q)$ . From the weak persistence we have  $\limsup_{t \rightarrow +\infty} I(t) > \epsilon$ . This means that there exists an increasing positive sequence  $(\eta_j)_{j=0}^{+\infty}$ ,  $\eta_j \rightarrow +\infty$ , such that  $I(\eta_j) > \epsilon$ , for all  $j \in \mathbb{N}$ . Suppose by contradiction that for any  $\epsilon' \in (0, \epsilon]$ , there exists a non-negative initial condition  $(S_0, I_0, \Phi_p, \Phi_q)$ , with  $I_0 > 0$ , such that  $\liminf_{t \rightarrow +\infty} I(t) \leq \epsilon'$ . Hence, there exists a positive increasing sequence  $(t_j)_{j=0}^{+\infty}$ ,  $t_j > \eta_j$ , and a positive decreasing sequence  $(\gamma_j)_{j=0}^{+\infty}$ ,  $\lim_{j \rightarrow +\infty} \gamma_j = 0$ , such that

$$I(t_j) < \gamma_j < \epsilon' \leq \epsilon.$$

As  $I$  is a continuous function and using the intermediate value theorem, there exists an increasing sequence  $(\nu_j)_{j=0}^{+\infty}$ ,  $\eta_j < \nu_j < t_j$ , such that  $I(\nu_j) = \epsilon$  and  $I(t) < \epsilon$ , for all  $t \in (\nu_j, t_j)$ . The sequence  $(I(\nu_j))_{j=0}^{+\infty}$  is constant (equal to  $\epsilon$ ) and the sequence  $(S(\nu_j))_{j=0}^{+\infty}$ , is bounded. Then, according to the Bolzano-Weierstrass theorem, there exists a subsequence of  $(S(\nu_j))_{j=0}^{+\infty}$ , also denoted  $(S(\nu_j))_{j=0}^{+\infty}$ , such that  $\lim_{j \rightarrow +\infty} S(\nu_j) = l_S \geq 0$ . We are also keeping the same notation for the subsequence associated with the constant sequence  $(I(\nu_j))_{j=0}^{+\infty}$ .

We recall the two following problems

$$u(t) = \begin{cases} hS(t) + \alpha e^{-a_p \tau} u(t - \tau), & t > 0, \\ \Phi_p(t), & t \in [-\tau, 0], \end{cases}$$

and

$$v(t) = \begin{cases} kI(t) + \alpha' e^{-(a_q + \mu)\tau'} v(t - \tau'), & t > 0, \\ \Phi_q(t), & t \in [-\tau', 0]. \end{cases}$$

They correspond to the general problem given by Equation (12) with respectively  $\Psi(t) = hS(t)$ ,  $\xi = \alpha e^{-a_p \tau}$ ,  $\phi = \Phi_p$  and  $\Psi(t) = kI(t)$ ,  $\xi = \alpha' e^{-(a_q + \mu)\tau'}$ ,  $\phi = \Phi_q$ , with  $S$  and  $I$  uniformly continuous on  $[0, +\infty)$ , because their derivatives are bounded. Therefore, thanks to Lemma 4.3 and Corollary 4.4, we have the existence of a subsequence of  $(\nu_j)_{j=0}^{+\infty}$  which we note the same, and  $\bar{u} \in \mathcal{C}([-\tau, 0], \mathbb{R})$ ,  $\bar{v} \in \mathcal{C}([-\tau', 0], \mathbb{R})$  such that

$$\lim_{j \rightarrow +\infty} u(\nu_j + \cdot) = \bar{u} \quad \text{and} \quad \lim_{j \rightarrow +\infty} v(\nu_j + \cdot) = \bar{v},$$

with

$$\bar{u}(0) = hl_S + \alpha e^{-a_p \tau} \bar{u}(-\tau) \quad \text{and} \quad \bar{v}(0) = k\epsilon + \alpha' e^{-(a_q + \mu)\tau'} \bar{v}(-\tau').$$

We return to System (7) and consider the solution with the initial condition starting from the limit  $(S_0, I_0, \Phi_p, \Phi_q) = (l_S, \epsilon, \bar{u}, \bar{v})$ . From Theorem 5.1, there exist  $T_\infty > 0$  and  $m \in (0, \epsilon]$  such that

$$I(T_\infty) > \epsilon \quad \text{and} \quad I(t) > m \quad \text{for all } t \in (0, T_\infty).$$

Now we have to find a contradiction. Let  $\tilde{I}_j(t) = I(\nu_j + t)$ ,  $t > 0$ ,  $j \in \mathbb{N}$ . We have

$$\tilde{I}_j(0) = I(\nu_j) = \epsilon, \quad \lim_{j \rightarrow +\infty} S(\nu_j) = l_S, \quad \lim_{j \rightarrow +\infty} u(\nu_j + \cdot) = \bar{u}(\cdot) \quad \text{and} \quad \lim_{j \rightarrow +\infty} v(\nu_j + \cdot) = \bar{v}(\cdot).$$

Let  $j \in \mathbb{N}$ . We consider the solution of (7) with the initial condition

$$(S_0, I_0, \Phi_p, \Phi_q) = (S(\nu_j), \epsilon, u(\nu_j + \cdot), v(\nu_j + \cdot))$$

and we choose  $T_j$ , so that

$$\tilde{I}_j(T_j) > \epsilon \quad \text{and} \quad \tilde{I}_j(t) > m, \quad \text{for all } t \in (0, T_j). \quad (18)$$

We can choose  $j$  sufficiently large so that

$$\gamma_j < m, \quad \text{for all } t \in (0, T_j).$$

We denote  $\tilde{t}_j := t_j - \nu_j$ . So, for all  $t \in (0, \tilde{t}_j)$ , we have  $\nu_j + t \in (\nu_j, t_j)$  and

$$\tilde{I}_j(t) = I(\nu_j + t) < \gamma_j < \epsilon \quad \text{and} \quad \tilde{I}_j(\tilde{t}_j) = I(t_j) < \gamma_j < \epsilon. \quad (19)$$

This gives us three different scenarios to analyze.

- Suppose that  $T_j < \tilde{t}_j$ . Then,  $\nu_j + T_j \in (\nu_j, t_j)$  and  $\tilde{I}_j(T_j) < \epsilon$ . This contradicts (18).
- Suppose that  $T_j = \tilde{t}_j$ . Then,  $\nu_j + T_j = t_j$  and  $\tilde{I}_j(T_j) = I(t_j) < \epsilon$ . This contradicts (18).
- Suppose that  $T_j > \tilde{t}_j$ . Then, we have from (18),  $\tilde{I}_j(\tilde{t}_j) = I(t_j) > m > \gamma_j$ . This contradicts (19).

We conclude that there exists  $\epsilon' \in (0, \epsilon]$  such that

$$\liminf_{t \rightarrow +\infty} I(t) > \epsilon'.$$

□

One could think of using classical results from uniform persistence theory (see, for example, [32]), but these results cannot be applied directly to our case, as they require conditions on the semiflow generated by the system. These include the existence of a compact attractor, which is not straightforward to satisfy for difference equations. We have therefore chosen to provide a direct proof for the uniform persistence of our system.

## 6 Global asymptotic stability of the steady-states

In this section, we show the global attractivity of the disease-free equilibrium when  $\mathcal{R}_0 \leq 1$  and the global attractivity of the endemic equilibrium when  $\mathcal{R}_0 > 1$ .

**Theorem 6.1.** *1. Suppose that  $\mathcal{R}_0 \leq 1$ . Then, the disease-free equilibrium  $E^0$  is globally attractive.*

*2. Suppose that  $\mathcal{R}_0 > 1$ . Then, the disease-free equilibrium is unstable and the endemic equilibrium  $E^*$  is globally attractive.*

*Proof.* Let  $\bar{E} := (\bar{S}, \bar{I}, \bar{u}, \bar{v})$  be an equilibrium, disease-free or endemic. We set, for  $t \geq 0$ ,  $\tilde{S}(t) = S(t) - \bar{S}$  and  $\tilde{u}(t) = u(t) - \bar{u}$  and we keep  $I(t)$  and  $v(t)$  unchanged. Note that  $I(t)$  and  $v(t)$  are non-negative functions, while  $\tilde{S}(t)$  and  $\tilde{u}(t)$  need not necessarily be. The system (7) becomes

$$\begin{cases} \tilde{S}'(t) &= -(h + a_S)\tilde{S}(t) - \beta\tilde{S}(t)I(t) - \beta\bar{S}I(t) + \beta\bar{S}\bar{I} + (1 - \alpha)e^{-a_p\tau}\tilde{u}(t - \tau), \\ I'(t) &= -(\mu + k + a_I)I(t) + \beta\tilde{S}(t)I(t) + \beta\bar{S}I(t) + (1 - \alpha')e^{-(a_q + \mu)\tau'}v(t - \tau'), \\ \tilde{u}(t) &= h\tilde{S}(t) + \alpha e^{-a_p\tau}\tilde{u}(t - \tau), \\ v(t) &= kI(t) + \alpha' e^{-(a_q + \mu)\tau'}v(t - \tau'). \end{cases} \quad (20)$$

The proof is based on the following Lyapunov functional

$$V(t) := \frac{\sigma}{2}\tilde{S}^2(t) + \int_{t-\tau}^t \tilde{u}^2(s)ds + \sigma\bar{S}f_{\bar{I}}(I(t)) + \frac{\sigma\bar{S}(1 - \alpha')e^{-(a_q + \mu)\tau'}}{1 - \alpha'e^{-(a_q + \mu)\tau'}} \int_{t-\tau'}^t f_{\bar{v}}(v(s))ds,$$

for  $t > 0$ , with

$$0 < \sigma := 2 \frac{h(e^{2a_p\tau} - \alpha) + a_S(e^{2a_p\tau} - \alpha^2)}{(1 - \alpha)^2},$$

and  $(\tilde{S}(t), I(t), \tilde{u}(t), v(t)) \in \mathbb{R} \times \mathbb{R}^+ \times \mathbb{R} \times \mathbb{R}^+$ . The choice of the functions  $f_{\bar{I}}$  and  $f_{\bar{v}}$  depends on the equilibrium under study. In the case of disease-free equilibrium,  $\bar{I} = 0$  and  $\bar{v} = 0$  it is defined by

$$f_0(x) = x, \quad x > 0,$$

and in the case of the endemic equilibrium,  $\bar{I} = I^* > 0$  and  $\bar{v} = v^* > 0$ , it is given by

$$f_{x^*}(x) = x^* g\left(\frac{x}{x^*}\right), \quad x > 0, \quad \text{with } x^* = v^* \text{ or } x^* = I^*,$$

and the function  $g$  is defined for  $x > 0$ , by

$$g(x) := x - 1 - \ln(x).$$

Note that the function  $V$  is always non-negative for all  $t \geq 0$ . The function  $g$  is continuous, convex and non-negative and equal to zero only at  $x = 1$ . Indeed, for  $x > 0$ , we have  $g'(x) = 1 - \frac{1}{x}$  and  $g''(x) = \frac{1}{x^2} > 0$ .

The derivative of  $V$  along the solutions of System (20) is given by

$$\begin{aligned} V'(t) = & -\sigma \tilde{S}'(t) \tilde{S}(t) + \tilde{u}^2(t) - \tilde{u}^2(t - \tau) + \sigma \bar{S} I'(t) f_{\bar{I}}'(I(t)) \\ & + \eta (f_{\bar{v}}(v(t)) - f_{\bar{v}}(v(t - \tau'))), \quad t > 0, \end{aligned}$$

where

$$\eta := \frac{\sigma \bar{S} (1 - \alpha') e^{-(a_q + \mu)\tau'}}{1 - \alpha' e^{-(a_q + \mu)\tau'}}.$$

We replace  $\tilde{S}'(t)$  and  $\tilde{u}^2(t)$  by their expressions

$$\begin{aligned} V'(t) = & -\sigma(h + a_S) \tilde{S}^2(t) - \sigma \beta \tilde{S}^2(t) I(t) - \sigma \beta \bar{S} \tilde{S}(t) I(t) + \sigma \beta \bar{S} \bar{I} \tilde{S}(t) \\ & + \sigma(1 - \alpha) e^{-a_p \tau} \tilde{u}(t - \tau) \tilde{S}(t) + h^2 \tilde{S}^2(t) + (\alpha e^{-a_p \tau})^2 \tilde{u}^2(t - \tau) \\ & + 2h\alpha e^{-a_p \tau} \tilde{S}(t) \tilde{u}(t - \tau) - \tilde{u}^2(t - \tau) \\ & + \sigma \bar{S} I'(t) f_{\bar{I}}'(I(t)) \\ & + \eta (f_{\bar{v}}(v(t)) - f_{\bar{v}}(v(t - \tau'))). \end{aligned}$$

Then, by rearranging the terms and developing the expression of  $I'(t)$ , we obtain

$$\begin{aligned} V'(t) = & -(\sigma(h + a_S) - h^2) \tilde{S}^2(t) + \sigma(1 - \alpha) e^{-a_p \tau} \tilde{u}(t - \tau) \tilde{S}(t) \\ & + (\alpha e^{-a_p \tau})^2 \tilde{u}^2(t - \tau) + 2h\alpha e^{-a_p \tau} \tilde{S}(t) \tilde{u}(t - \tau) - \tilde{u}^2(t - \tau) \\ & - \sigma \beta \tilde{S}^2(t) I(t) - \sigma \beta \bar{S}(t) \tilde{S}(t) I(t) + \sigma \beta \bar{S} \bar{I} \tilde{S}(t) \\ & + \sigma \bar{S} \left( -(\mu + k + a_I) + \beta \tilde{S}(t) + \beta \bar{S} \right) I(t) f_{\bar{I}}'(I(t)) \\ & + \sigma \bar{S} (1 - \alpha') e^{-(a_q + \mu)\tau'} v(t - \tau') f_{\bar{I}}'(I(t)) \\ & + \eta (f_{\bar{v}}(v(t)) - f_{\bar{v}}(v(t - \tau'))). \end{aligned}$$

For the moment, we consider the same function  $V$  for both steady-states, *i.e.* disease-free or endemic. For all  $\bar{I} \geq 0$ , the following equalities hold

$$I(t) f_{\bar{I}}'(I(t)) = I(t) - \bar{I} \quad \text{and} \quad f_{\bar{I}}'(I(t)) = 1 - \frac{\bar{I}}{I(t)}.$$

Moreover, for all  $\bar{v} \geq 0$ ,

$$\begin{aligned} f_{\bar{v}}(v(t)) - f_{\bar{v}}(v(t - \tau')) &= v(t) - v(t - \tau) + \bar{v} \ln \left( \frac{v(t - \tau)}{v(t)} \right), \\ &= v(t) - v(t - \tau) + \bar{v} \left( \frac{v(t - \tau)}{v(t)} - 1 - g \left( \frac{v(t - \tau)}{v(t)} \right) \right). \end{aligned}$$

Then, we can write, for all  $\bar{I} \geq 0$  and  $\bar{v} \geq 0$ ,

$$\begin{aligned} V'(t) &= -(\sigma(h + a_S) - h^2) \tilde{S}^2(t) + \sigma(1 - \alpha)e^{-a_p \tau} \tilde{u}(t - \tau) \tilde{S}(t) \\ &\quad + (\alpha e^{-a_p \tau})^2 \tilde{u}^2(t - \tau) + 2h\alpha e^{-a_p \tau} \tilde{S}(t) \tilde{u}(t - \tau) - \tilde{u}^2(t - \tau) \\ &\quad - \sigma \beta \tilde{S}^2(t) I(t) - \sigma \bar{S} (\mu + k + a_I - \beta \bar{S}) (I(t) - \bar{I}) \\ &\quad + \sigma \bar{S} (1 - \alpha') e^{-(a_q + \mu) \tau'} v(t - \tau') \left( 1 - \frac{\bar{I}}{I(t)} \right) \\ &\quad + \eta \left( v(t) - v(t - \tau) + \bar{v} \left( \frac{v(t - \tau)}{v(t)} - 1 - g \left( \frac{v(t - \tau)}{v(t)} \right) \right) \right). \end{aligned}$$

We use the fact that  $v(t) = kI(t) + \alpha' e^{-(a_q + \mu) \tau'} v(t - \tau')$ , for  $t \geq 0$ , which allows us to get

$$\begin{aligned} V'(t) &= -(\sigma(h + a_S) - h^2) \tilde{S}^2(t) + \sigma(1 - \alpha)e^{-a_p \tau} \tilde{u}(t - \tau) \tilde{S}(t) \\ &\quad + (\alpha e^{-a_p \tau})^2 \tilde{u}^2(t - \tau) + 2h\alpha e^{-a_p \tau} \tilde{S}(t) \tilde{u}(t - \tau) - \tilde{u}^2(t - \tau) \\ &\quad - \sigma \beta \tilde{S}^2(t) I(t) - \sigma \bar{S} (\mu + k + a_I - \beta \bar{S}) (I(t) - \bar{I}) \\ &\quad + \sigma \bar{S} (1 - \alpha') e^{-(a_q + \mu) \tau'} v(t - \tau') \left( 1 - \frac{\bar{I}}{I(t)} \right) \\ &\quad + \eta (kI(t) + \alpha' e^{-(a_q + \mu) \tau'} v(t - \tau')) - \eta v(t - \tau') \\ &\quad + \eta \bar{v} \left( \frac{v(t - \tau)}{v(t)} - 1 - g \left( \frac{v(t - \tau)}{v(t)} \right) \right). \end{aligned}$$

By rearranging certain terms, we obtain

$$\begin{aligned} V'(t) &= -(\sigma(h + a_S) - h^2) \tilde{S}^2(t) + \sigma(1 - \alpha)e^{-a_p \tau} \tilde{u}(t - \tau) \tilde{S}(t) \\ &\quad + (\alpha e^{-a_p \tau})^2 \tilde{u}^2(t - \tau) + 2h\alpha e^{-a_p \tau} \tilde{S}(t) \tilde{u}(t - \tau) - \tilde{u}^2(t - \tau) \\ &\quad - \sigma \beta \tilde{S}^2(t) I(t) + (-\sigma \bar{S} (\mu + k + a_I - \beta \bar{S}) + \eta k) I(t) \\ &\quad + \sigma \bar{S} (\mu + k + a_I - \beta \bar{S}) \bar{I} \\ &\quad + \left( \sigma \bar{S} (1 - \alpha') e^{-(a_q + \mu) \tau'} \left( 1 - \frac{\bar{I}}{I(t)} \right) - \eta (1 - \alpha' e^{-(a_q + \mu) \tau'}) \right) v(t - \tau') \\ &\quad + \eta \bar{v} \left( \frac{v(t - \tau)}{v(t)} - 1 - g \left( \frac{v(t - \tau)}{v(t)} \right) \right). \end{aligned}$$

We recall the expression

$$\eta = \frac{\sigma \bar{S} (1 - \alpha') e^{-(a_q + \mu) \tau'}}{1 - \alpha' e^{-(a_q + \mu) \tau'}}.$$

This gives the following equality

$$\sigma\bar{S}(1-\alpha')e^{-(a_q+\mu)\tau'}\left(1-\frac{\bar{I}}{I(t)}\right)-\eta(1-\alpha'e^{-(a_q+\mu)\tau'})=-\sigma\bar{S}(1-\alpha')e^{-(a_q+\mu)\tau'}\frac{\bar{I}}{I(t)}.$$

Therefore, we obtain

$$\begin{aligned} V'(t) = & -(\sigma(h+a_S)-h^2)\tilde{S}^2(t)+\sigma(1-\alpha)e^{-a_p\tau}\tilde{u}(t-\tau)\tilde{S}(t) \\ & +(\alpha e^{-a_p\tau})^2\tilde{u}^2(t-\tau)+2h\alpha e^{-a_p\tau}\tilde{S}(t)\tilde{u}(t-\tau)-\tilde{u}^2(t-\tau) \\ & -\sigma\beta\tilde{S}^2(t)I(t)+(-\sigma\bar{S}(\mu+k+a_I-\beta\bar{S})+\eta k)I(t) \\ & +\sigma\bar{S}(\mu+k+a_I-\beta\bar{S})\bar{I} \\ & -\sigma\bar{S}(1-\alpha')e^{-(a_q+\mu)\tau'}\frac{\bar{I}}{I(t)}v(t-\tau') \\ & +\eta\bar{v}\left(\frac{v(t-\tau')}{v(t)}-1-g\left(\frac{v(t-\tau')}{v(t)}\right)\right). \end{aligned}$$

If we denote by

$$a:=\sigma(h+a_S)-h^2, \quad b:=\sigma(1-\alpha)+2h\alpha>0, \quad c:=e^{2a_p\tau}-\alpha^2>0,$$

we can see that the first part of the expression of  $V'(t)$  has the following form

$$\begin{aligned} & -(\sigma(h+a_S)-h^2)\tilde{S}^2(t)+\sigma(1-\alpha)e^{-a_p\tau}\tilde{u}(t-\tau)\tilde{S}(t) \\ & +(\alpha e^{-a_p\tau})^2\tilde{u}^2(t-\tau)+2h\alpha e^{-a_p\tau}\tilde{S}(t)\tilde{u}(t-\tau)-\tilde{u}^2(t-\tau) \\ & =-a\tilde{S}^2(t)+be^{-a_p\tau}\tilde{u}(t-\tau)\tilde{S}(t)-ce^{-2a_p\tau}\tilde{u}^2(t-\tau), \\ & =-c\left[\left(e^{-a_p\tau}\tilde{u}(t-\tau)-\frac{b}{2c}\tilde{S}(t)\right)^2-\frac{b^2-4ac}{4c^2}\tilde{S}^2(t)\right]. \end{aligned}$$

Let's first show that  $a:=\sigma(h+a_S)-h^2$  is also positive. Indeed, we have

$$a=\frac{2e^{2a_p\tau}(h+a_S)^2-2\alpha(h+\alpha a_S)(h+a_S)-h^2(1-\alpha)^2}{(1-\alpha)^2}.$$

Then, we claim that  $2e^{2a_p\tau}(h+a_S)^2-2\alpha(h+\alpha a_S)(h+a_S)-h^2(1-\alpha)^2>0$ . Indeed,

$$\begin{aligned} & 2e^{2a_p\tau}(h+a_S)^2-2\alpha(h+\alpha a_S)(h+a_S)-h^2(1-\alpha)^2 \\ & =2e^{2a_p\tau}(h^2+a_S^2+2ha_S)-2\alpha(h^2+ha_S+\alpha ha_S+\alpha a_S^2)-h^2(1-\alpha)^2, \\ & =2a_S^2(e^{2a_p\tau}-\alpha^2)+4ha_S e^{2a_p\tau}-2ha_S\alpha-2\alpha^2ha_S \\ & \quad +h^2(2e^{2a_p\tau}-2\alpha-1-\alpha^2+2\alpha), \\ & =2a_S^2(e^{2a_p\tau}-\alpha^2)+2ha_S(2e^{2a_p\tau}-\alpha-\alpha^2)+h^2(2e^{2a_p\tau}-1-\alpha^2). \end{aligned}$$

Since  $0<\alpha<1$ , then

$$2a_S^2(e^{2a_p\tau}-\alpha^2)+2ha_S(2e^{2a_p\tau}-\alpha-\alpha^2)+h^2(2e^{2a_p\tau}-1-\alpha^2)>0.$$

We have proved that  $a>0$ . Now we need to show that

$$b^2-4ac\leq 0.$$

$$\begin{aligned}
b^2 - 4ac &= (\sigma(1 - \alpha) + 2h\alpha)^2 - 4(\sigma(h + a_S) - h^2)(e^{2a_p\tau} - \alpha^2), \\
&= \sigma^2(1 - \alpha)^2 + \sigma(4h\alpha(1 - \alpha) - 4(h + a_S)(e^{2a_p\tau} - \alpha^2)) + 4h^2\alpha^2 \\
&\quad + 4h^2(e^{2a_p\tau} - \alpha^2), \\
&= (1 - \alpha)^2\sigma^2 + 4((h + \alpha a_S)\alpha - (h + a_S)e^{2a_p\tau})\sigma + 4h^2e^{2a_p\tau}.
\end{aligned}$$

We obtain a second-degree polynomial of  $\sigma$ , that we denote  $P(X)$ . The derivative of  $P(X)$  is

$$P'(X) = 2(1 - \alpha)^2X + 4((h + \alpha a_S)\alpha - (h + a_S)e^{2a_p\tau}).$$

The argument of the minimum of  $P$ ,  $\underline{X}$ , satisfies

$$P'(\underline{X}) = 0.$$

In fact, it is given by

$$\underline{X} = 2 \frac{(h + \alpha a_S)\alpha - (h + a_S)e^{2a_p\tau}}{(1 - \alpha)^2} := \sigma.$$

To show that  $P(\sigma) \leq 0$ , it suffices to show that the discriminant of the polynomial  $P(X)$  is positive. This discriminant is given by

$$\begin{aligned}
\Delta &= 16((h + \alpha a_S)\alpha - (h + a_S)e^{2a_p\tau})^2 - 16(1 - \alpha)^2h^2e^{2a_p\tau}, \\
&= 16[(h + \alpha a_S)\alpha - (h + a_S)e^{2a_p\tau} + (1 - \alpha)he^{a_p\tau}] \\
&\quad \times [(h + \alpha a_S)\alpha - (h + a_S)e^{2a_p\tau} - (1 - \alpha)he^{a_p\tau}], \\
&= 16[h(\alpha + e^{a_p\tau})(1 - e^{a_p\tau}) + a_S(\alpha^2 - e^{2a_p\tau})] \\
&\quad \times [h(\alpha - e^{a_p\tau})(1 + e^{a_p\tau}) + a_S(\alpha^2 - e^{2a_p\tau})], \\
&> 0.
\end{aligned}$$

Therefore, we have

$$P(\sigma) = b^2 - 4ac < 0.$$

Let's return to the derivative of  $V$

$$\begin{aligned}
V'(t) &= -c \left[ \left( e^{-a_p\tau} \tilde{u}(t - \tau) - \frac{b}{2c} \tilde{S}(t) \right)^2 - \frac{b^2 - 4ac}{4c^2} \tilde{S}^2(t) \right] \\
&\quad - \sigma \beta \tilde{S}^2(t) I(t) + (-\sigma \bar{S}(\mu + k + a_I - \beta \bar{S}) + \eta k) I(t) \\
&\quad + \sigma \bar{S}(\mu + k + a_I - \beta \bar{S}) \bar{I} - \sigma \bar{S}(1 - \alpha') e^{-(a_q + \mu)\tau'} \frac{\bar{I}}{I(t)} v(t - \tau') \\
&\quad + \eta \bar{v} \left( \frac{v(t - \tau')}{v(t)} - 1 - g \left( \frac{v(t - \tau')}{v(t)} \right) \right).
\end{aligned}$$

Moreover, we have for all  $t \geq 0$ ,

$$-c \left( e^{-a_p\tau} \tilde{u}(t - \tau) - \frac{b}{2c} \tilde{S}(t) \right)^2 \leq 0 \quad \text{and} \quad -\sigma \beta \tilde{S}^2(t) I(t) \leq 0.$$

We introduce the notation

$$\nu := -\frac{b^2 - 4ac}{4c} > 0.$$

Thus, we have

$$\begin{aligned}
V'(t) \leq & -\nu\tilde{S}^2(t) + (-\sigma\bar{S}(\mu + k + a_I - \beta\bar{S}) + \eta k) I(t) \\
& + \sigma\bar{S}(\mu + k + a_I - \beta\bar{S})\bar{I} - \sigma\bar{S}(1 - \alpha')e^{-(a_q + \mu)\tau'} \frac{\bar{I}}{I(t)} v(t - \tau') \\
& + \eta\bar{v} \left( \frac{v(t - \tau')}{v(t)} - 1 - g \left( \frac{v(t - \tau')}{v(t)} \right) \right). \tag{21}
\end{aligned}$$

Let us now distinguish between the case where  $\bar{E}$  is the disease-free equilibrium  $E^0$  and the case where it is the endemic equilibrium  $E^*$ .

- In the case  $\bar{E} = E^0 := (S^0, 0, u^0, 0)$ , *i.e.*  $\bar{I} = 0$  and  $\bar{v} = 0$ , with  $\mathcal{R}_0 < 1$ , the inequality (21) becomes

$$V'(t) \leq -\nu\tilde{S}^2(t) + (-\sigma S^0(\mu + k + a_I - \beta S^0) + \eta k) I(t).$$

Using the expression of  $\eta$ , we obtain

$$V'(t) \leq -\nu\tilde{S}^2(t) - \sigma S^0 \left[ \frac{k + \mu + a_I - [k + (\mu + a_I)\alpha']e^{-(a_q + \mu)\tau'}}{1 - \alpha'e^{-(a_q + \mu)\tau'}} \right] [1 - \mathcal{R}_0] I(t).$$

Therefore, since  $\mathcal{R}_0 < 1$ , we have

$$V'(t) \leq -\nu\tilde{S}^2(t), \quad t > 0.$$

Consequently, using the second assertion of Lemma 4.5 and Lemma 4.1, we get

$$\lim_{t \rightarrow +\infty} \tilde{S}(t) = 0 \quad \text{and} \quad \lim_{t \rightarrow +\infty} \tilde{u}(t) = 0.$$

We conclude that

$$\lim_{t \rightarrow +\infty} S(t) = S^0 \quad \text{and} \quad \lim_{t \rightarrow +\infty} u(t) = u^0.$$

Furthermore, since  $V$  is decreasing and  $\lim_{t \rightarrow +\infty} V(t) = \underline{V}$ , we have  $\lim_{t \rightarrow +\infty} V'(t) = 0$ . Remember that

$$V'(t) \leq -\nu\tilde{S}^2(t) - \sigma S^0 \left[ \frac{k + \mu + a_I - [k + (\mu + a_I)\alpha']e^{-(a_q + \mu)\tau'}}{1 - \alpha'e^{-(a_q + \mu)\tau'}} \right] [1 - \mathcal{R}_0] I(t) \leq 0.$$

As

$$\lim_{t \rightarrow +\infty} V'(t) = 0, \quad \lim_{t \rightarrow +\infty} \tilde{S}^2(t) = 0,$$

and

$$\sigma S^0 \left[ \frac{k + \mu + a_I - [k + (\mu + a_I)\alpha']e^{-(a_q + \mu)\tau'}}{1 - \alpha'e^{-(a_q + \mu)\tau'}} \right] [1 - \mathcal{R}_0] > 0,$$

we obtain, thanks to squeeze theorem

$$\lim_{t \rightarrow +\infty} I(t) = 0.$$

Finally, we use Lemma 4.1 with the inhomogeneous equation

$$v(t) - \alpha'e^{-(a_q + \mu)\tau'} v(t - \tau') = kI(t),$$



to get

$$\lim_{t \rightarrow +\infty} v(t) = 0.$$

In conclusion, we have shown that for  $\mathcal{R}_0 < 1$ ,

$$\lim_{t \rightarrow +\infty} (S(t), I(t), u(t), v(t)) = E^0 := (S^0, 0, u^0, 0).$$

- We now consider the endemic equilibrium  $\bar{E} = E^*$  with  $\bar{I} = I^* > 0$ ,  $\bar{v} = v^* > 0$  and we suppose that  $\mathcal{R}_0 > 1$ . We have  $v^* = \frac{k}{1 - \alpha' e^{-(a_q + \mu)\tau'}} I^*$ . Using the expression of  $S^*$  we can obtain the following equality

$$(\mu + k + a_I - \beta S^*) (I(t) - I^*) = v^* (1 - \alpha') e^{-(a_q + \mu)\tau'} \left( \frac{I(t)}{I^*} - 1 \right).$$

Thus, inequality (21) becomes

$$\begin{aligned} V'(t) \leq & -\nu \tilde{S}^2(t) - \left( \sigma S^* \frac{v^*}{I^*} (1 - \alpha') e^{-(a_q + \mu)\tau'} - \eta k \right) I(t) \\ & + \sigma S^* v^* (1 - \alpha') e^{-(a_q + \mu)\tau'} - \sigma S^* (1 - \alpha') e^{-(a_q + \mu)\tau'} \frac{I^*}{I(t)} v(t - \tau') \\ & + \eta v^* \left( \frac{v(t - \tau')}{v(t)} - 1 - g \left( \frac{v(t - \tau')}{v(t)} \right) \right). \end{aligned}$$

We can check that

$$\sigma S^* \frac{v^*}{I^*} (1 - \alpha') e^{-(a_q + \mu)\tau'} - \eta k = 0.$$

We still have to show that

$$\begin{aligned} & \sigma S^* v^* (1 - \alpha') e^{-(a_q + \mu)\tau'} - \sigma S^* (1 - \alpha') e^{-(a_q + \mu)\tau'} \frac{I^*}{I(t)} v(t - \tau') \\ & + \eta v^* \left( \frac{v(t - \tau')}{v(t)} - 1 - g \left( \frac{v(t - \tau')}{v(t)} \right) \right) \leq 0. \end{aligned}$$

Next, we put  $M := \sigma S^* (1 - \alpha') e^{-(a_q + \mu)\tau'}$  and  $L := 1 - \alpha' e^{-(a_q + \mu)\tau'}$ . Notice that  $M = \eta L$ . We rewrite the previous expression as

$$\begin{aligned} & -\eta v^* g \left( \frac{v(t - \tau')}{v(t)} \right) + v^* [M - \eta] + \eta v^* \frac{v(t - \tau')}{v(t)} - M I^* \frac{v(t - \tau')}{I(t)} \\ & = -\eta v^* \frac{v(t - \tau')}{v(t)} + \eta v^* + \eta v^* \ln \left( \frac{v(t - \tau')}{v(t)} \right) + \eta v^* [L - 1] + \eta v^* \frac{v(t - \tau')}{v(t)} \\ & \quad - \eta v^* L^2 \frac{v(t - \tau')}{k I(t)}, \\ & = \eta v^* \left( \ln \left( \frac{v(t - \tau')}{v(t)} \right) + L - L^2 \frac{v(t - \tau')}{k I(t)} \right), \\ & = \eta v^* \left( \ln \left( \frac{v(t - \tau')}{k I(t) + \alpha' e^{-(a_q + \mu)\tau'} v(t - \tau')} \right) + L - L^2 \frac{v(t - \tau')}{k I(t)} \right), \\ & = \eta v^* \left( \ln \left( \frac{x}{1 + Dx} \right) + 1 - D - (1 - D)^2 x \right), \end{aligned}$$

where

$$x := \frac{v(t - \tau')}{kI(t)} \quad \text{and} \quad D := \alpha' e^{-(a_q + \mu)\tau'}.$$

For the sake of simplicity, we omit dependence on variables, in particular time. We notice that  $0 \leq D < 1$ . We can easily show that

$$f(x) := \ln \left( \frac{x}{1 + Dx} \right) + 1 - D - (1 - D)^2 x \leq 0, \quad \text{for } x \geq 0.$$

In fact, we have

$$f'(x) = -(1 - D)^2 + \frac{1}{x(1 + Dx)}, \quad \text{for } x \geq 0.$$

We remark that  $f''(x) \leq 0$ , for all  $x \geq 0$ . We can check that the maximum of the function  $f$  is reached at the critical point  $\tilde{x} = 1/(1 - D)$  with

$$f \left( \frac{1}{1 - D} \right) = \ln \left( \frac{\tilde{x}}{1 + D\tilde{x}} \right) = 0.$$

We proved that

$$V'(t) \leq - \left( \frac{4ac - b^2}{4c} \right) \tilde{S}^2(t) =: -\nu \tilde{S}^2(t), \quad \text{with } \nu > 0.$$

Since  $\tilde{S}(t)$  is bounded, then  $\tilde{S}'(t)$  is also bounded from the equation of  $\tilde{S}$ . Thus,  $\tilde{S}(t)$  is uniformly continuous. We can then apply the second statement of Lemma 4.5 and obtain

$$\lim_{t \rightarrow +\infty} \tilde{S}(t) = 0.$$

On the other hand,  $\tilde{u}$  satisfies the inhomogeneous difference equation

$$D(\tilde{u}_t) = h\tilde{S}(t),$$

with

$$D(\phi) := \phi(0) - \alpha e^{-a_p \tau} \phi(-\tau), \quad \phi \in \mathcal{C}([-\tau, 0], \mathbb{R}), \quad 0 < \alpha e^{-a_p \tau} < 1$$

and  $\lim_{t \rightarrow +\infty} \tilde{S}(t) = 0$ .

By applying Lemma 4.1, we show that

$$\lim_{t \rightarrow +\infty} \tilde{u}(t) = 0.$$

This means that

$$\lim_{t \rightarrow +\infty} S(t) = S^* \quad \text{and} \quad \lim_{t \rightarrow +\infty} u(t) = u^*.$$

Remember the expression of  $V$

$$V(t) := \frac{\sigma}{2} \tilde{S}^2(t) + \int_{t-\tau}^t \tilde{u}^2(s) ds + \sigma S^* f_{I^*}(I(t)) + \eta \int_{t-\tau'}^t f_{v^*}(v(s)) ds.$$

Going to the limit we get

$$\underline{V} = \inf_{s \geq 0} V(s) := \lim_{t \rightarrow +\infty} \left( \sigma S^* f_{I^*}(I(t)) + \eta \int_{t-\tau'}^t f_{v^*}(v(s)) ds \right).$$

We know that the function  $t \mapsto \tilde{S}(t)$  is bounded and differentiable, so there exists a sequence  $(t_n)_n$  such that  $t_n \rightarrow +\infty$  and  $\lim_{n \rightarrow +\infty} \tilde{S}'(t_n) = 0$ . Hence, thanks to the first equation of System (20),  $\lim_{n \rightarrow +\infty} I(t_n)$  exists and satisfies

$$0 = -\beta S^* \lim_{n \rightarrow +\infty} I(t_n) + \beta S^* I^*.$$

This implies that

$$\lim_{n \rightarrow +\infty} I(t_n) = I^*.$$

As in the proof of Theorem 5.3, we use the theorem of Ascoli-Arzelà, to prove that

$$\lim_{n \rightarrow +\infty} v_n(\theta) := \lim_{n \rightarrow +\infty} v(t_n + \theta) = \tilde{v}(\theta) \quad \text{exists in } \mathcal{C}([-\tau', 0], \mathbb{R}).$$

Then, we have from the last equation of System (7)

$$\tilde{v}(0) = kI^* + \alpha' e^{-(a_q + \mu)\tau'} \tilde{v}(-\tau').$$

Consequently,

$$\lim_{n \rightarrow +\infty} f_{I^*}(I(t_n)) = f_{I^*}(I^*) = 0 \quad \text{and} \quad \lim_{n \rightarrow +\infty} f_{v^*}(v_n(\theta)) = f_{v^*}(\tilde{v}(\theta)) = 0,$$

for  $\theta \in [-\tau', 0]$ . We therefore conclude that

$$\underline{V} = \lim_{n \rightarrow +\infty} \left( \sigma S^* f_{I^*}(I(t_n)) + \eta \int_{-\tau'}^0 f_{v^*}(v_n(\theta)) d\theta \right) = 0.$$

In fact, we have already proved that this limit exists when  $t \rightarrow +\infty$ . Then,

$$\lim_{t \rightarrow +\infty} \left( \sigma S^* f_{I^*}(I(t)) + \eta \int_{-\tau'}^0 f_{v^*}(v(t + \theta)) d\theta \right) = 0.$$

We deduce that

$$\lim_{t \rightarrow +\infty} f_{I^*}(I(t)) = 0 \quad \text{and} \quad \lim_{t \rightarrow +\infty} f_{v^*}(v(t + \cdot)) = 0.$$

By the properties of the function  $g$ , we conclude that the function  $\tilde{v}(\cdot) = v^*$  is constant and

$$\lim_{t \rightarrow +\infty} I(t) = I^* \quad \text{and} \quad \lim_{t \rightarrow +\infty} v(t) = v^*.$$

Then, the endemic equilibrium  $E^*$  is globally attractive if  $\mathcal{R}_0 > 1$ .

To complete the proof, we have in the case  $\mathcal{R}_0 = 1$  that the two steady-states are identical and the global stability is obtained by passing to the limit.

□

## 7 Discussion and numerical simulations

In this section, a simulation study is carried out to verify our results and deduce how the parameters affect the model and therefore the epidemic. First, we illustrate the temporal evolution of  $S$ ,  $I$ ,  $P$  and  $Q$  for a given set of parameters, for two different pairs  $(h, k)$ , in Figure 3. First, in black, we take  $(h, k) = (0.3, 0.7)$ , which gives  $\mathcal{R}_0 = 1.158$ , second, in red, we take  $(h, k) = (0.7, 0.3)$ , which gives  $\mathcal{R}_0 = 0.905$ . When  $\mathcal{R}_0 > 1$ , the disease persists and the solution reaches, if its limit exists, the endemic equilibrium  $E^* = (S^*, I^*, P^*, Q^*) = (6.4, 0.2, 10.9, 0.2)$ . On the contrary the disease-free equilibrium, given by  $E^0 = (S^0, I^0, P^0, Q^0) = (4.04, 0, 15.96, 0)$  is reached when  $\mathcal{R}_0 < 1$ . Therefore, with this configuration, *i.e.* this set of parameters (which is given in the caption of Figure 3), we can say that protecting susceptible individuals is better than isolating infected ones. Figure 4 shows the influence of  $h$ ,  $k$ ,  $\mu$  and  $\beta$  on  $\mathcal{R}_0$ . As expected, the more the infected disappear (*i.e.*  $\mu$  increases), the more the infection decreases. Indeed, as  $\mu$  increases, the area where  $\mathcal{R}_0 < 1$  becomes larger. However, we observe the opposite phenomenon when the parameter  $\beta$  increases. And for an infection rate  $\beta$  too large it is not possible to find  $(h, k) \in [0, 1] \times [0, 1]$  such that  $\mathcal{R}_0(h, k) = 1$ . Using Lemma 3.4 and Figure 2, we can see that it is not always possible to find a pair  $(\tau, \tau') \in \mathbb{R}_+^2$  such that  $\mathcal{R}_0(\tau, \tau') = 1$ . Nevertheless, the more susceptible individuals are protected and the more infected individuals are isolated, the lower the basic reproduction number.

Figure 5 compares the evolution of  $S^0$  and  $S^*$  as a function of similar parameters. In the first column, we compare the effect of the delays,  $\tau$  and  $\tau'$ , on  $S^0$  and  $S^*$ , for different values of  $\mu$ . The second column compares the effect of  $h$  and  $k$ , the rates of protection and isolation. Finally, the third shows the effect of renewals of protection or isolation. We observe greater variations on the curves of  $S^0$ , particularly when varying the delay or the renewal rate. This suggests that changing the protection parameters will have a greater impact on the dynamics.

Figure 6 gives the partial rank correlation coefficients (PRCCs) with  $\mathcal{R}_0$  as the output. The input parameters are chosen from a uniform distribution using the Latin Hypercube Sampling. The aim of calculating PRCCs is to determine the relationships between each input parameter and  $\mathcal{R}_0$ , the output one, while keeping all the other input parameters constant. The qualitative relationship is given by the sign of the PRCC, its magnitude indicates the importance of the uncertainty in the input variable in contributing to the imprecision in predicting the value of the outcome variable, [15, 17]. We see that the increase of  $\Lambda$  and  $\beta$  promotes the increase of  $\mathcal{R}_0$ , and these two parameters are the most influential. Moreover, related to the contribution of parameters to  $\mathcal{R}_0$ , we see that the parameters associated to protection ( $h$ ,  $\alpha$  and  $\tau$ ) are more important than those associated to isolation ( $k$ ,  $\alpha'$  and  $\tau'$ ).

In fact, it is always preferable to act simultaneously, protecting susceptible people and isolating infected individuals. Vaccination is also considered to be a highly effective solution because it offers "long-lasting" protection, but it is sometimes expensive and it is not always possible to obtain a vaccine quickly. In a situation like this, where the aim is to be effective quickly, and if a choice had to be made, it would seem preferable to keep susceptible individuals isolated (*i.e.* short-term temporary protection) rather than those who are infected. In fact, if we choose to isolate the infected, a single infected individual who is not isolated can continue spreading the disease.

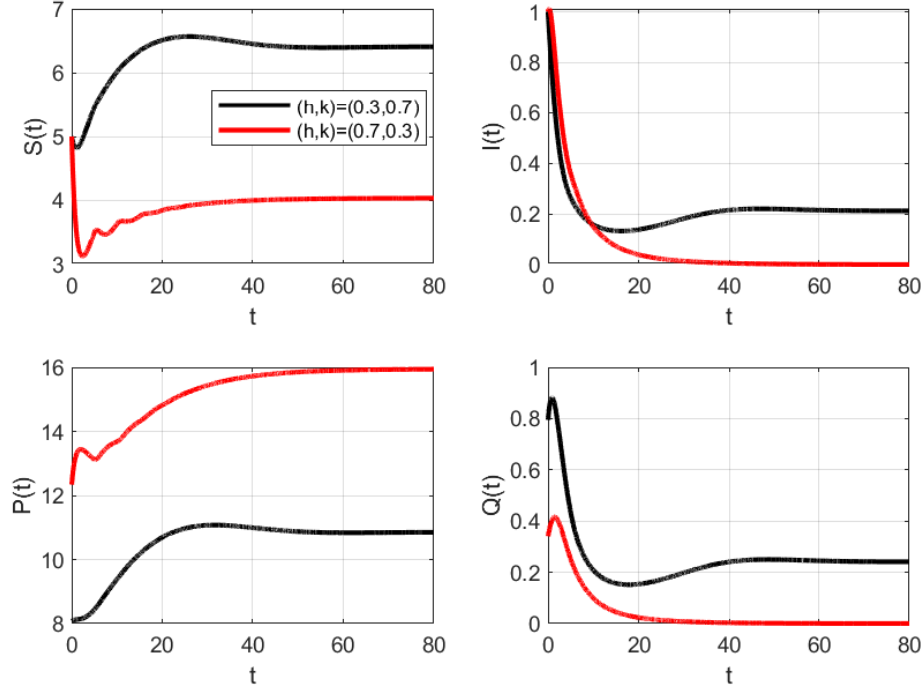

Figure 3: Temporal evolution of  $S$ ,  $I$ ,  $P$  and  $Q$  for two different pairs  $(h, k)$ . In black  $(h, k) = (0.3, 0.7)$ , which gives  $\mathcal{R}_0 = 1.158$ , in red  $(h, k) = (0.7, 0.3)$ , which gives  $\mathcal{R}_0 = 0.905$ . The other parameters are  $\Lambda = 2$ ,  $\mu = 0.5$ ,  $\beta = 0.2$ ,  $a_S = 0.1$ ,  $a_I = 0.1$ ,  $a_p = 0.1$ ,  $a_q = 0.1$ ,  $\tau = 5$ ,  $\tau' = 5$ ,  $\alpha = 0.5$ ,  $\alpha' = 0.5$ .

We studied a SIR epidemiological model containing two age structured temporary classes. We considered a period of temporary protection for susceptible individuals (by vaccination or medication, for instance) and a period of temporary isolation for infected individuals. Our system with two delays is reduced, using the method of characteristic, to a hybrid model with two differential equations and two difference equations. We established the basic reproduction number,  $\mathcal{R}_0$ , which is a threshold for the existence of an endemic equilibrium. Notice that there is always a disease-free equilibrium. The global asymptotic stability of the two steady-states was proved using well-chosen Lyapunov functionals. If  $\mathcal{R}_0 < 1$  the disease-free steady-state is globally asymptotic stable, otherwise if  $\mathcal{R}_0 > 1$ , the endemic steady-state is globally asymptotic stable. We studied the behavior of  $\mathcal{R}_0$  as a function of the parameters  $h$ ,  $k$ ,  $\alpha$ ,  $\alpha'$ ,  $\tau$ ,  $\tau'$  and  $\mu$ . This allows us to say which of the protection or isolation of individuals facilitates the control of the epidemic.

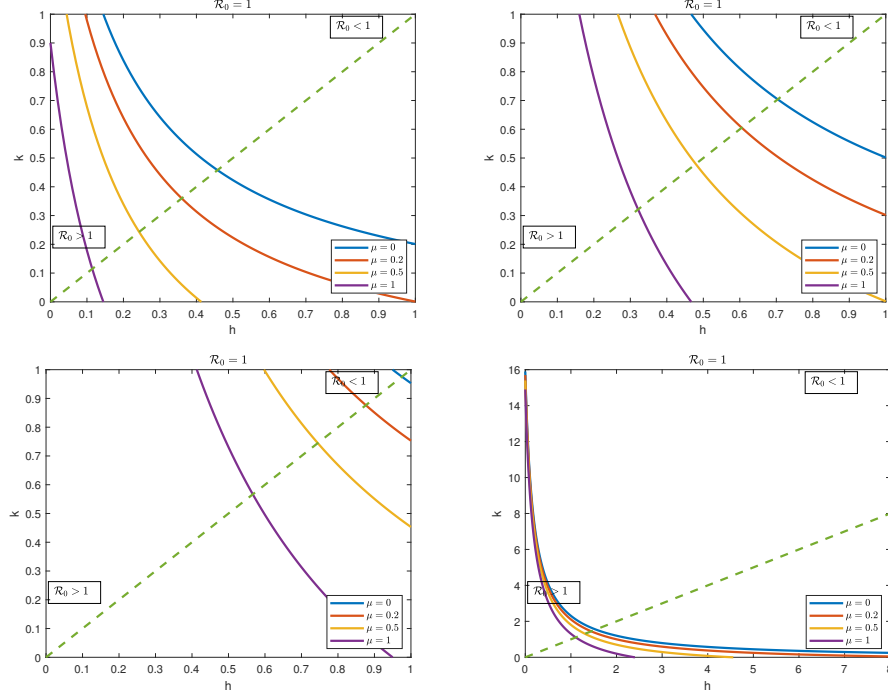

Figure 4:  $\mathcal{R}_0(h, k) = 1$ , for different values of  $\mu$  (blue line:  $\mu = 0$ , red line:  $\mu = 0.2$ , yellow line:  $\mu = 0.5$ , purple line:  $\mu = 1$ ) and  $\beta$  (top left:  $\beta = 0.1$ , top right:  $\beta = 0.2$ , bottom left:  $\beta = 0.35$ , bottom right:  $\beta = 0.8$ ), with  $\Lambda = 2$ ,  $a_S = 0.1$ ,  $a_I = 0.1$ ,  $a_p = 0.1$ ,  $a_q = 0.1$ ,  $h = 0.385$ ,  $k = 0.385$ ,  $\tau = 5$ ,  $\tau' = 5$ ,  $\alpha = 0.5$ ,  $\alpha' = 0.5$ .

## Acknowledgments

A.C. thanks the IMU-CDC and Simons Foundation for partially supporting this work with a grant. M.A. and C.D. thank the Inria international associate teams DIFAIRE and MoCoVec.

## References

- [1] M. Adimy, A. Chekroun, C. Dugourd-Camus and H. Meghelli, Global asymptotic stability of a hybrid differential–difference system describing SIR and SIS epidemic models with a protection phase and a nonlinear force of infection, *Qual. Theory Dyn. Syst.*, **23**, **34** (2024), URL <https://doi.org/10.1007/s12346-023-00891-z>.
- [2] M. Adimy, A. Chekroun and B. Kazmierczak, Traveling waves in a coupled reaction-diffusion and difference model of hematopoiesis, *Journal of Differential Equations*, **262**(7) (2017), 4085–4128, URL <https://doi.org/10.1016/j.jde.2016.12.009>.
- [3] M. Adimy, A. Chekroun and C. P. Ferreira, Global dynamics of a differential-difference system: a case of Kermack-McKendrick SIR model with age-

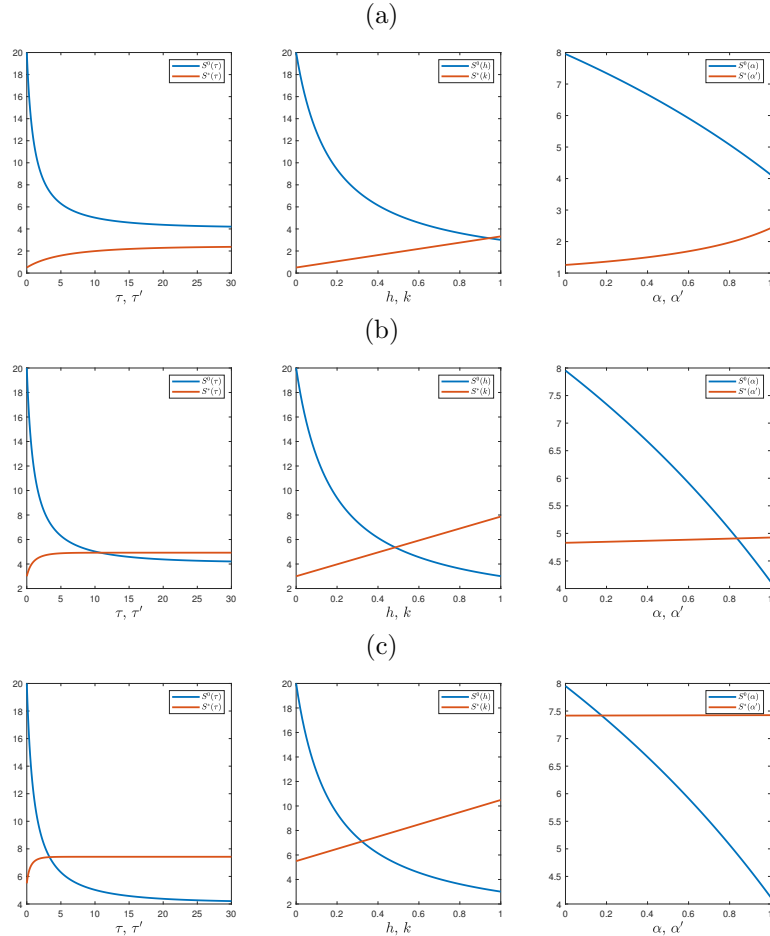

Figure 5: Comparison of the evolution of  $S^0$  (blue lines) and  $S^*$  (red lines) as a function of one parameter for different values of  $\mu$  ((a) top:  $\mu = 0$ , (b) middle:  $\mu = 0.5$ , (c) bottom:  $\mu = 1$ ). When fixed, the parameter values are  $\Lambda = 2$ ,  $\beta = 0.2$ ,  $a_S = 0.1$ ,  $a_I = 0.1$ ,  $a_p = 0.1$ ,  $a_q = 0.1$ ,  $h = 0.385$ ,  $k = 0.385$ ,  $\tau = 5$ ,  $\tau' = 5$ ,  $\alpha = 0.5$ ,  $\alpha' = 0.5$ . It seems that there are greater variations on the curves of  $S^0$ , particularly when varying the delay or renewal rate.

structured protection phase, *Mathematical Biosciences and Engineering*, **17(2)** (2020), 1329–1354, URL <https://doi.org/10.3934/mbe.2020067>.

- [4] M. Adimy, A. Chekroun and T. Kuniya, Coupled reaction-diffusion and difference system of cell-cycle dynamics for hematopoiesis process with Dirichlet boundary conditions, *Journal of Mathematical Analysis and Applications*, **479(1)** (2019), 1030–1068, URL <https://doi.org/10.1016/j.jmaa.2019.06.066>.
- [5] M. Adimy, A. Chekroun and T. Kuniya, Traveling waves of a differential-difference diffusive Kermack-McKendrick epidemic model with age-structured

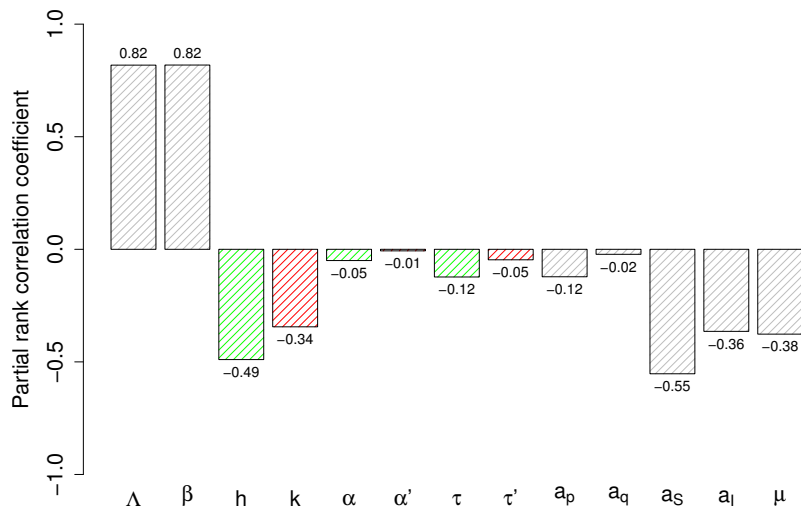

Figure 6: Sensitivity analysis with  $\mathcal{R}_0$  as the output. The input parameters are  $\Lambda \in [0, 10]$ ,  $\beta, h, k, \alpha, \alpha' \in [0, 1]$ ,  $\tau, \tau' \in [0, 20]$ ,  $a_p, a_q, a_s, a_I, \mu \in [0, 1]$ , they are chosen from a uniform distribution using the Latin Hypercube Sampling. The PRCCs obtained show that the parameters with the greatest influence on  $\mathcal{R}_0$  are  $\Lambda$  and  $\beta$ . We have coloured in green the parameters associated with the protection of the susceptible and in red those associated with the isolation of the infected. It would appear that the parameters associated with protection have a greater influence on the  $\mathcal{R}_0$ .

protection phase, *Journal of Mathematical Analysis and Applications*, **505(1)** (2022), 125464, URL <https://doi.org/10.1016/j.jmaa.2021.125464>.

- [6] M. Adimy, A. Chekroun and T. Kuniya, Global asymptotic stability for a distributed delay differential-difference system of a Kermack-McKendrick SIR model, *Applicable Analysis*, **102(12)** (2023), 3463–3475, URL <https://doi.org/10.1080/00036811.2022.2075352>.
- [7] M. Adimy, A. Chekroun and T.-M. Touaoula, Age-structured and delay differential-difference model of hematopoietic stem cell dynamics, *Discrete and Continuous Dynamical Systems - Series B*, **20(9)** (2015), 2765–2791, URL <https://doi.org/10.3934/dcdsb.2015.20.2765>.
- [8] M. Adimy, J. Molina, L. Pujon-Menjouet, G. Ranson and J. Wu, Forecasting the effect of pre-exposure prophylaxis (PrEP) on HIV propagation with a system of differential-difference equations with delay, *Mathematics*, **10(21)** (2022), 4093, URL <https://doi.org/10.3390/math10214093>.
- [9] M. Alam, K. M. A. Kabir and J. Tanimoto, Based on mathematical epidemiology and evolutionary game theory, which is more effective: quarantine or isola-



- tion policy?, *Journal of Statistical Mechanics: Theory and Experiment*, **2020** (2020), 033502, URL <https://dx.doi.org/10.1088/1742-5468/ab75ea>.
- [10] M. Alexander, C. Bowman, S. Moghadas, R. Summers, A. Gumel and B. Sahai, A Vaccination Model for Transmission Dynamics of Influenza, *SIAM Journal on Applied Dynamical Systems*, **3**(4) (2004), 503–524, URL <https://doi.org/10.1137/030600370>.
- [11] M. Alexander, S. Moghadas, P. Rohani and A. Summers, Modelling the effect of a booster vaccination on disease epidemiology, *Journal of Mathematical Biology*, **52** (2006), 290–306, URL <https://doi.org/10.1007/s00285-005-0356-0>.
- [12] B. Balachandran, T. Kalmar-Nagy and D. E. Gilsinn, *Delay Differential Equations: Recent Advances and New Directions*, Springer-Verlag New York Inc., New York, 2009.
- [13] D. Bernoulli, Essai d’une nouvelle analyse de la mortalité causée par la petite vérole, *Mem. Math. Phys. Acad. Roy. Sci., Paris* (1766).
- [14] A. S. Bhadauria, R. Pathak and M. Chaudhary, A SIQ mathematical model on COVID-19 investigating the lockdown effect, *Infectious Disease Modelling*, **6** (2021), 244–257, URL <https://doi.org/10.1016/j.idm.2020.12.010>.
- [15] S. M. Blower and H. Dowlatabadi, Sensitivity and uncertainty analysis of complex models of disease transmission: An HIV model, as an example, *International Statistical Review / Revue Internationale de Statistique*, **62**(2) (1994), 229–243, URL <https://doi.org/10.2307/1403510>.
- [16] L.-M. Cai, C. Modnak and J. Wang, An age-structured model for cholera control with vaccination, *Applied Mathematics and Computation*, **299** (2017), 127–140, URL <https://doi.org/10.1016/j.amc.2016.11.013>.
- [17] W. J. Conover, *Practical Nonparametric statistics*, John Wiley & Sons Inc., New York, NY, 1980.
- [18] M. A. Cruz and J. K. Hale, Stability of functional differential equations of neutral type, *Journal of Differential Equations*, **7**(2) (1970), 334–355, URL [https://doi.org/10.1016/0022-0396\(70\)90114-2](https://doi.org/10.1016/0022-0396(70)90114-2).
- [19] E. Dangbé, D. Irépran, A. Perasso and D. Békollé, Mathematical modelling and numerical simulations of the influence of hygiene and seasons on the spread of cholera, *Mathematical Biosciences*, **296** (2018), 60–70, URL <https://doi.org/10.1016/j.mbs.2017.12.004>.
- [20] X. Duan, S. Yuan and X. Li, Global stability of an SVIR model with age of vaccination, *Applied Mathematics and Computation*, **226** (2014), 528–540, URL <https://doi.org/10.1016/j.amc.2013.10.073>.
- [21] H. I. Freedman and P. Moson, Persistence definitions and their connections, *Proceedings of the American Mathematical Society*, **109**(4) (1990), 1025–1033, URL <https://doi.org/10.2307/2048133>.

- [22] H. I. Freedman, S. Ruan and M. Tang, Uniform persistence and flows near a closed positively invariant set, *Journal of Dynamics and Differential Equations*, **6** (1994), 583–600, URL <https://doi.org/10.1007/BF02218848>.
- [23] K. Gu and Y. Liu, Lyapunov-Krasovskii functional for uniform stability of coupled differential-functional equations, *Automatica*, **45(3)** (2009), 798–804, URL <https://doi.org/10.1016/j.automatica.2008.10.024>.
- [24] J. K. Hale and S. M. Verduyn Lunel, *Introduction to Functional Differential Equations*, Springer, 1993.
- [25] W. O. Kermack and A. G. McKendrick, A contribution to the mathematical theory of epidemics, *Proc. R. Soc. Lond. A*, **115(772)** (1927), 700–721, URL <https://doi.org/10.1098/rspa.1927.0118>.
- [26] H. K. Khalil, *Nonlinear systems; 3rd ed.*, Prentice-Hall, Upper Saddle River, NJ, 2002.
- [27] P. Pepe, On the asymptotic stability of coupled delay differential and continuous time difference equations, *Automatica*, **41(1)** (2005), 107–112, URL <https://doi.org/10.1016/j.automatica.2004.08.011>.
- [28] P. Pepe and E. Verriest, On the stability of coupled delay differential and continuous time difference equations, *IEEE Transactions on Automatic Control*, **48(8)** (2003), 5567–5572, URL <https://doi.org/10.1109/CDC.2003.1271888>.
- [29] A. Perasso, Global stability and uniform persistence for an infection load-structured SI model with exponential growth velocity, *Communications on Pure & Applied Analysis*, **18(1)** (2019), 15–32, URL <https://doi.org/10.3934/cpaa.2019002>.
- [30] R. Ross, The prevention of malaria, *John Murray, London*, 1910.
- [31] M. A. Safi and A. B. Gumel, Mathematical analysis of a disease transmission model with quarantine, isolation and an imperfect vaccine, *Computers & Mathematics with Applications*, **61(10)** (2011), 3044–3070, URL <https://doi.org/10.1016/j.camwa.2011.03.095>.
- [32] H. L. Smith and H. R. Thieme, *Dynamical Systems and Population Persistence*, American Mathematical Society, 2011.
- [33] H. M. Yang, L. P. Lombardi Junior, F. F. M. Castro and A. C. Yang, Mathematical modeling of the transmission of SARS-CoV-2-evaluating the impact of isolation in São-Paulo state (Brazil) and lockdown in Spain associated with protective measures on the epidemic of COVID-19, *PLOS ONE*, **16** (2021) URL <https://doi.org/10.1371/journal.pone.0252271>.
- [34] W. Yang, C. Sun and J. Arino, Global analysis for a general epidemiological model with vaccination and varying population, *Journal of Mathematical Analysis and Applications*, **372(1)** (2010), 208–223, URL <https://doi.org/10.1016/j.jmaa.2010.07.017>.

- [35] A. Zeb, E. Alzahrani, V. S. Erturk and G. Zaman, Mathematical model for coronavirus disease 2019 (COVID-19) containing isolation class, *BioMed Research International*, **2020** (2020), 1–7, URL <https://doi.org/10.1155/2020/3452402>.