



**HAL**  
open science

# Improved mapping of flood affected villages in India: a novel three-stage approach using PolSAR polarization signatures and ensembled dilated CNNs

Gopal Singh Phartiyal, Dharmendra Singh, Hussein Yahia

## ► To cite this version:

Gopal Singh Phartiyal, Dharmendra Singh, Hussein Yahia. Improved mapping of flood affected villages in India: a novel three-stage approach using PolSAR polarization signatures and ensembled dilated CNNs. *International Journal of Remote Sensing*, 2023, pp.1-26. 10.1080/01431161.2023.2283905 . hal-04314118

**HAL Id: hal-04314118**

**<https://inria.hal.science/hal-04314118>**

Submitted on 18 Dec 2023

**HAL** is a multi-disciplinary open access archive for the deposit and dissemination of scientific research documents, whether they are published or not. The documents may come from teaching and research institutions in France or abroad, or from public or private research centers.

L'archive ouverte pluridisciplinaire **HAL**, est destinée au dépôt et à la diffusion de documents scientifiques de niveau recherche, publiés ou non, émanant des établissements d'enseignement et de recherche français ou étrangers, des laboratoires publics ou privés.



Distributed under a Creative Commons Attribution 4.0 International License

# **Improved Mapping of Flood Affected Villages in India: A Novel Three-Stage Approach Using PolSAR Polarization Signatures and Ensembled Dilated CNNs**

Gopal Singh Phartiyal<sup>a</sup>, Dharmendra Singh<sup>b</sup>, Hussein Yahia<sup>c</sup>

*<sup>a,b</sup>Department of Electronics and Communication Engineering*

*Indian Institute of Technology Roorkee, Roorkee, Uttarakhand – 247667, India*

*<sup>c</sup>GeoStat, INRIA, Bordeaux Sud-Ouest-33405, France*

`gphartiyal@ec.iitr.ac.in`

ORCID identifier: <https://orcid.org/0000-0003-1974-4926>

## 1 Abstract

2 During floods, updated and accurate information on affected human settlements helps save  
3 lives and reduces time to rescue. Therefore, approaches that can provide reliable  
4 information during floods via the use of all-weather and real-time functional technology is  
5 highly needful. The study presented here attempts to efficiently and precisely map human  
6 settlements in the Indian sub-continent during floods via a three-stage approach which uses  
7 PolSAR data. However, the segregation of human settlements in India even with PolSAR  
8 data is challenging because the built-up structures in the villages of rural India are closely  
9 packed and are randomly oriented w.r.t. each other. This condition either hinders their  
10 segregation or otherwise induces false alarms during extraction. More descriptive land  
11 cover characterization features and powerful feature classifiers may address this challenge.  
12 The study in this paper proposes a novel approach to efficiently detect and map flood  
13 affected villages which utilize polarization signatures from PolSAR imagery, ensemble-of -  
14 dilated-convolutions based CNNs, apriori knowledge, and image morphology. The  
15 approach broadly involves three stages; –first, built-up area extraction from a PolSAR  
16 image, -second, detection of villages in a built-up area image and, -third, identification and  
17 mapping of villages that are affected by the flood. In the first stage, an ensemble of varying  
18 dilated-convolutions based novel CNN classifier which directly utilizes PolSAR-2  
19 polarization signatures (PSs) in window-mode as features are developed to extract built-up  
20 areas. The second stage provides a novel village detection filter based on apriori  
21 knowledge and image morphology to detect actual villages and mask out the false objects.  
22 Finally, in the third stage, flood affected villages are mapped via a series of morphological  
23 operations based degree-of-intersection measure. Experiments are conducted on both;  
24 simulated and natural flooded area datasets. Experimental results show 81% detection  
25 accuracy and 100% mapping performance of the proposed approach which indicates its  
26 potential as an effective flood affected village mapping system.

27 **Keywords**— Fully polarimetric SAR, Polarization Signatures, Ensembled-Dilated-  
28 Convolutions.

29

30 **1. Introduction**

31 A significant 65% of the Indian population lives in towns and villages and floods are the most  
32 frequent, widespread, and damaging disasters for majority this population (*Flood Affected Area*  
33 *Atlas of India - Satellite Based Study 2023*; Jain and Singh 2023). During floods in Indian  
34 villages, monitoring and dissemination of rescue operations becomes both critical and  
35 challenging at the same time (Mukherjee 2023). Crucial due to the fact that a large proportion of  
36 population lives here and challenging because of resource constraints in these regions for  
37 frequent update on the situation. A very good example of resource constraints on rural India  
38 compared to urban cities is the study done by researchers in (Young et al. 2022). The study  
39 highlights the difference in the social media resource exploitation for information and rescue  
40 updates between major cities like Kochi and Tiruvananthapuram and other rural districts of  
41 Kerala.

42 Therefore, to address this crucial but challenging task, a rapid and reliable monitoring is key to  
43 minimize the loss of human lives and property in rural parts of India. An accurate and updated  
44 near-real-time information of flood affected rural areas can lead to an efficient disaster  
45 mitigation plans.

46 In terms of technologies for flood affected area monitoring in rural India, satellite imaging is one  
47 of the most helpful and reliable technology. This resource is geographically and socially  
48 unconstrained i.e same fidelity to cities and villages . Especially, the synthetic aperture radar  
49 (SAR) imaging modality has proved to be a very effective and all-weather successful technology  
50 for monitoring flood affected areas and planning rescue operations (Martinis et al.,  
51 2015), (Giustarini et al., 2013)(Sharma et al., 2008).

52 In particular, the ability of satellite PolSAR imaging instruments to remotely sense the changes  
53 in polarization states which in-turn are introduced by the “interaction” of EM waves with earth  
54 surface objects (in this case, land covers).

55 For example, built-up structures usually show double bounce scattering response. It means that  
56 these built-up structures appear bright (high backscattering response) in the “HH” image.

57 Whereas, tall vegetation (e.g. forests) show volume scattering response (bright in in “HV”  
58 image), and smooth surfaces such as water show single bounce scattering response.

59 PolSAR imaging has also proved its popularity, significance and unique effectiveness in flood  
60 monitoring and mitigation also (Pradhan et al., 2016)(Schnebele et al., 2014)(Dasgupta A. et al.,  
61 2017)(Giustarini et al., 2013)

62 However, mapping human settlements during floods in India is difficult even with  
63 PolSAR imagery. The built-up structures (e.g.: Houses) in these human settlements (especially in  
64 villages of rural India), are closely packed and randomly oriented with respect to reach other.  
65 Therefore, these villages show volume scattering response along with double bounce scattering  
66 response in a PolSAR image. The mixed scattering response from these villages hinders their  
67 segregation from tall vegetation in a PolSAR image (Garg and Singh, 2018; Mishra et al., 2017;  
68 Phartiyal et al., 2020). Therefore, the detection and mapping of these villages during a flood  
69 event is challenging even with PolSAR imagery as there is high risk of false alarms and hence  
70 ineffective rescue operations. To address such challenges, raw PolSAR data has been  
71 transformed and represented in different bases and forms namely decompositions, factorizations,  
72 coherency, covariance etc. in various flood monitoring studies (Dasgupta A. et al., 2017;  
73 Dumitru et al., 2015; Manavalan et al., 2013; Silvana and Laura, 2018). The current study

74 proposes the utilization of PolSAR polarization signatures (PSs) features for the detection and  
75 mapping of villages that are affected by flood.

76 Polarization signature (PS) is a two-dimensional or 2D representation depicting  
77 backscatter response from any target at a particular polarization state. Polarization signature or  
78 PSs are introduced in (Kennaugh and Sloan, 1952) and has been depicted graphically by many  
79 researchers in different perspectives (Bielecka et al., 2014; van Zyl et al., 1987). PSs have been  
80 proved useful for characterization of land covers (Jafari et al., 2015)(Phartiyal et al., 2020). A  
81 comparison of PSs-based features and decomposition-based features for land cover  
82 characterization is presented in (Phartiyal et al., 2020). Their study demonstrates the significance  
83 of the utilization of PSs over decomposition-based features for land cover characterization and  
84 classification in mixed land cover scenarios. This is motivating since a similar scenario is at hand  
85 here and therefore, the current study considers PSs as PolSAR features. Theoretical background  
86 on PSs is discussed under section 2.

87 A lack of studies that directly utilize the PSs is notable although normalized signature  
88 correlation mapper (NSCM), a correlation-based measure, and normalized Euclidean distance  
89 (NED), a distance-based measure, are the popular PSs-derived features used in various  
90 applications (de Carvalho and Meneses, 2000), (Maurya et al., 2016).. This is because of the fact  
91 that PSs are two dimensional features and a two-dimensional feature extractor would be more  
92 efficient to exploit it. As of today, convolutional deep neural networks (CNNs) are one of the  
93 most popular, efficient, and powerful image (two-dimensional) feature extractors. Their unique  
94 characteristic of “local connectivity” and “parameter sharing” makes them best tools to extract  
95 complex and localized features from images (Yann LeCun et al., 2015). Authors in (Phartiyal et  
96 al., 2019) explored the significance of CNNs as PSs feature extractors and indicated to the

97 potential of PSs and CNN based models in other applications. However, more detailed study is  
98 required to this end. Therefore, the current study extensively explores the utilization of CNNs as  
99 PS feature extractors in order to map flood affected human settlements with PolSAR imagery.  
100 The current study also explores the [p;arization signature sub-space via dilated convolutions and  
101 aggregates the different convolutions to achieve better performance.

102 To summarize, this paper presents a novel approach to detect and map villages affected  
103 by a flood with the help of PolSAR PSs, CNNs, *apriori* knowledge and image morphology. The  
104 novel approach involves three stages. These are;

105 –*first*, design and development of PSs based novel CNN model for extraction of built-up  
106 areas from PolSAR image which contains the flooded region,

107 –*second*, development of methodology for design of village detection filters based on *apriori*  
108 knowledge and image morphology and,

109 –*third*, development of another methodology for identification, and mapping of flood  
110 affected villages using image morphology.

111 This paper is divided into following sections. The fundamentals of the CNNs and the PSs  
112 are discussed in section 2. Section 3 provides detailed information on the materials used which  
113 involves study areas and datasets considered, and ancillary information collected for the study.  
114 Section 4 discusses the three-stage approach development for mapping flood affected villages.  
115 Qualitative and quantitative evaluation of the results is also in this section. At last, section 5  
116 concludes the study.

## 117 2. Theoretical Background

### 118 *Polarization Signatures*

119 Polarization signature (PS) is a peculiar representation of backscattering behaviour of a target, or  
120 in the case of current study, a land cover. PSs are a two-dimensional in nature. In a polarization  
121 signature representation, the  $y$ -axis and the  $x$ -axis represent orientation angle and ellipticity angle  
122 respectively and the  $z$ -axis represent the received backscattered power coefficient ( $\sigma^\circ$ ). The tilt  
123 or orientation angle ( $\psi$ ) spans from  $-90^\circ$  to  $90^\circ$  whereas the ellipticity angle ( $\chi$ ) spans from  $-45^\circ$   
124 to  $45^\circ$ . The signatures are computed using equation (1). The ellipticity angle represents to the  
125 polarization behaviour (i.e. elliptical, circular or linear polarization). On the other hand, the  
126 orientation or tilt angle represents to the polarization states (i.e. either horizontal polarization or  
127 vertical polarization (Jong-Sen Lee et al., 1997)).

$$128 \quad \sigma(\chi_l, \psi_l, \chi_m, \psi_m) = \frac{4\pi}{k} \begin{pmatrix} 1 \\ \cos 2\chi_l \cos 2\psi_l \\ \cos 2\chi_l \sin 2\psi_l \\ \sin 2\chi_l \end{pmatrix} (\mathbf{K}) \begin{pmatrix} 1 \\ \cos 2\chi_m \cos 2\psi_m \\ \cos 2\chi_m \sin 2\psi_m \\ \sin 2\chi_m \end{pmatrix} \quad (1)$$

129 where  $\sigma$  represents backscattering coefficient, suffix  $m$  and  $l$  represent received and  
130 transmit combinations respectively. Given the polarization characteristics of the receiving  
131 antenna,  $\mathbf{K}$  i.e. the Kennaugh matrix, represents the received power (Antenna Laboratory, 1952).  
132 It is alternatively termed as the Stokes scattering operator or the Stokes scattering matrix.  
133 Computation of the kennaugh parameters is done similar to (Harold, 2007). Further,  $k$  is the  
134 propagation constant. Two variants of PSs are computed namely co-polarized polarization  
135 signatures and cross-polarized polarization signatures.



136 The co-polarized signature is calculated via a transmit and receive settings of  $\psi_l = \psi_m$   
 137 and  $\chi_l = \chi_m$ , whereas the cross-polarized signature is calculated via a transmit and receive  
 138 settings of  $\psi_l = 90^\circ + \psi_m$ , and  $\chi_l = -\chi_m$ . Figure 1 is the co-polarized PS of a sample of a land  
 139 cover.

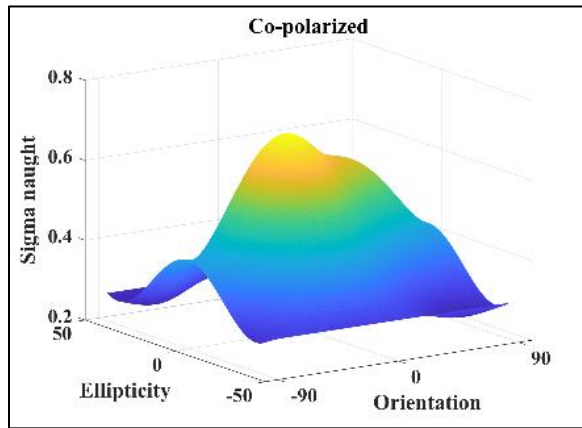

140  
 141 **Figure 1** Land cover class sample co-polarized signature.

142 ***Convolutional Neural Networks***

143 Convolutional neural networks have become a popular neural network type that utilizes the deep  
 144 learning technology very well. Fundamental CNN models were proposed in (Ian Goodfellow et  
 145 al., 2017)(Ciresan et al., 2012) (Fukushima and Miyake, 1982) (LeCun et al., 1998)(Zhang et al.,  
 146 1991) in the early stages but have quite matured now. For the sake of completeness, the building  
 147 blocks but not limited to of a conventional CNN are listed here. These are: a convolutional layer  
 148 with kernel size, activation function, strides and dilation strategy settings, a pooling layer with  
 149 strides and dilation strategy settings, a dropout layer with dropout fraction, a fully connected  
 150 layer with node count and activation function, and a loss layer.

151 Imagine a CNN with  $L$  layers (including pooling, dropout, or loss), the state vector of the  
 152 output of the  $l^{\text{th}}$  convolutional layer is denoted by  $\mathbf{o}^l$ , where  $l = \{1, 2, 3, \dots, L\}$  and  $\mathbf{o}^0$  represents  
 153 the input. Let's say the input is passed onto to a 1D, 2D or 3D convolutional layer based on  
 154 application. The convolution also intakes a kernel size, filter count, stride and dilation strategy,  
 155 and activation function. For the sake of reader's interest, a 2D convolution is elucidated here.  
 156 The convolution plus pooling in the  $l^{\text{th}}$  layer is represented in equation (2).

$$157 \quad \mathbf{o}^l = \text{pool}(g(\mathbf{o}^{l-1} \otimes \mathbf{W}_l + \mathbf{b}_l)) \quad (2)$$

158 where,  $\otimes$  indicates to the convolution operation and *pool* denotes to a spatial  
 159 aggregation strategy. Weights of the links connecting the  $(m - 1)^{\text{th}}$  convolutional layer to the  
 160  $m^{\text{th}}$  layer resides in the matrix  $\mathbf{W}_l$  whereas the vector  $\mathbf{b}_l$  is the bias term. A non-linear pointwise  
 161 activation function  $g(\cdot)$  is applied Subsequently. For the selection of dominant features, finally, a  
 162 pooling layer is placed with a certain window.

163 If required, any number of convolutional and/or pooling layers queued in any order to  
 164 constitute a feature extraction architecture that is hierarchical in nature. The last convolution or  
 165 pooling layer features are reprojected to a one-dimensional feature. Further, this feature is input  
 166 to a "fully connected" or alternatively termed as "dense" layer which can be perceived as a  
 167 typical multi perceptron layer. At the end of a CNN network, the final layer is usually a dense  
 168 layer with either a "linear" activation function (for "regression" scenarios) or a dense layer with  
 169 a "SoftMax" activation function (for "classification" scenarios) layer. The node count at this  
 170 layer matches the number of outputs desired.

171 The weights,  $\{\mathbf{W}_1, \mathbf{W}_2, \dots, \mathbf{W}_L\}$  and the biases,  $\{\mathbf{b}_1, \mathbf{b}_2, \dots, \mathbf{b}_L\}$  of the CNN represents the  
 172 parameters of the model. These are learned iteratively and optimized jointly via objective (e.g.

173 overall accuracy in case of classification) optimization over constraints such as “training” set.  
174 Equivalently, models can be realized for 1D or 3D convolution application scenarios.

175 The aforementioned network in whole, still expresses a single differentiable score  
176 function from the 2D input on one end to class scores at the other. The property that 2D CNN  
177 architectures make the explicit assumption that the inputs are images. As explored and utilized  
178 in the case of PSs in this study which allows encoding certain properties into the architecture.  
179 This in turn make the proceeding operations and functions more efficient. CNNs with deep  
180 learning have found their application in PolSAR data as well (Zhu et al., 2017).

## 181 **Materials and Methods**

### 182 *Study Area*

183 For critical analysis, development and evaluation of the proposed three-stage approach, three  
184 sites are considered. The first study area is the “Roorkee” city which is situated near the “Rajaji”  
185 national park at the foothills of the great Himalayas. This study area spans from  $29^{\circ}48'10''N$   
186 latitude,  $78^{\circ}4'5''E$  longitude to  $29^{\circ}57'4''N$  latitude,  $77^{\circ}51'54''E$  longitude. It covers around 361  
187  $km^2$  of landscape including multiple land covers. This study area is termed as ‘Roorkee’ study  
188 area in this paper. Figure 2(a) shows a true colour Google Earth image of Roorkee. Another  
189 study area is the Haridwar city and its neighbouring region. This area extends from  $29^{\circ}49'23''N$   
190 latitude,  $78^{\circ}10'5''E$  longitude to  $29^{\circ}58'23''N$  latitude,  $77^{\circ}49'52''E$  longitude. The area amounts  
191 to about 270  $km^2$  of landscape again including multiple land covers such as the river Ganges.  
192 This second study area is termed as ‘Haridwar’ study area in this article. Figure 3(a) shows a true  
193 colour Google Earth image of Haridwar. The third study area is considered for validation of the  
194 developed approach. This study area is Patna and neighbouring region which were affected

195 during the ‘Bihar 2016’ floods.

### 196 *Satellite Data*

197 For the Roorkee and Haridwar study regions, raw single look complex SAR data acquired by the  
198 JAXA’s PALSAR-2 L-band fully polarimetric SAR instrument onboard the ALOS-2 satellite on  
199 March 13, 2015 is considered. The raw “single look complex” PolSAR data is multilooked,  
200 speckle filtered, calibrated, and terrain corrected in that order to obtain backscattering ( $\sigma^\circ$ )  
201 coefficients (Phartiyal et al., 2017). Speckle filtering with “Gamma MAP” polarimetric filter is  
202 performed analogous to (Mishra et al., 2017) with a  $3 \times 3$  window size. Calibration and terrain  
203 correction are performed in method similar to (Phartiyal et al., 2017). Four features namely HH,  
204 HV, VH, and VV are achieved. Intuitively, VH and HV are identical and therefore redundant,  
205 only HH, VH, and VV are considered further. Figure 2(b) shows a false colour image of the pre-  
206 processed Roorkee dataset and Figure 3(b) shows a false colour image of the pre-processed  
207 Haridwar dataset. In addition, for the Patna study area, PALSAR-2 PolSAR image acquired on  
208 September 3, 2016 is considered as validation data.

### 209 *Ground Truth*

210 Ground truth is collected on two counts. First, ground truth sample points are collected for  
211 classifier training and validation. Bare soil (BS), built-up, tall vegetation (TV), short vegetation  
212 (SV), and water are the five land cover classes considered. On the basis of visual inspection,  
213 ground truth class sample points are measured directly on the terrain. A total of 1200 data points  
214 are collected separately for two i.e. Roorkee, and Haridwar study areas. More details of the  
215 ground truth survey are shown in Table 1.

216 Second, the total number of villages (a common term opted here to represent all types of  
217 human settlements in the study region) in each study area are counted for validation of the  
218 proposed approach. Table 1 also lists the actual number of villages in the Roorkee and Haridwar  
219 study areas. Further, Figure 4 highlights the villages in the Roorkee and Haridwar study regions  
220 captured from Google Earth imagery. Any village in the rural parts of India consists of a  
221 minimum of 30 houses and is spread over a minimum area of 5000 m<sup>2</sup>. These physical  
222 dimensions help in detection of villages in a PolSAR image

223 It is important to note here that in this paper; different terminologies have been used at  
224 different stages to represent different versions of built-up areas. Basic terminologies are defined  
225 here.

- 226 • Built-up structure: Man-made structures.
- 227 • Built-up area: A collection of built-up structures.
- 228 • Village or town: Built-up area larger than a predefined size.
- 229 • Object: A connected group of image pixels.
- 230 • Detected villages: Villages that have been successfully detected
- 231 • Flooded villages: Villages that are affected by flood

232 These terminologies help to better understand the different stages of the study.

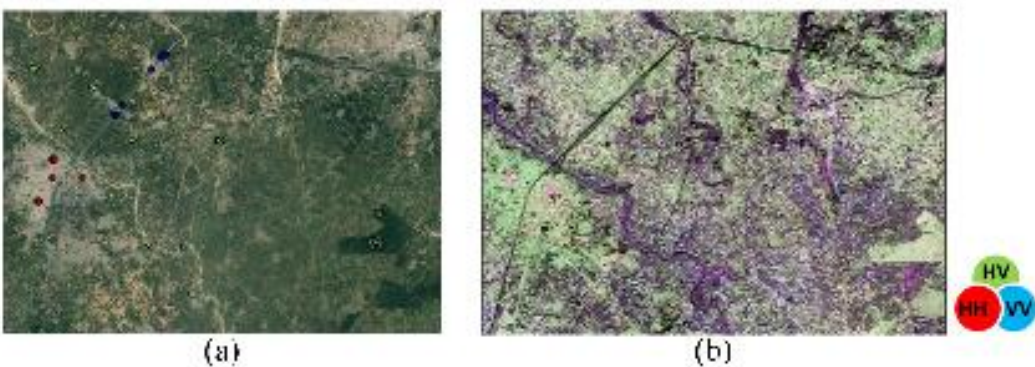

233  
234 Figure 2. (a): Imagery of the Roorkee collected from Google Earth with major land cover classes  
235 marked. (b): FCC of the pre-processed March 13, 2015 PolSAR data.

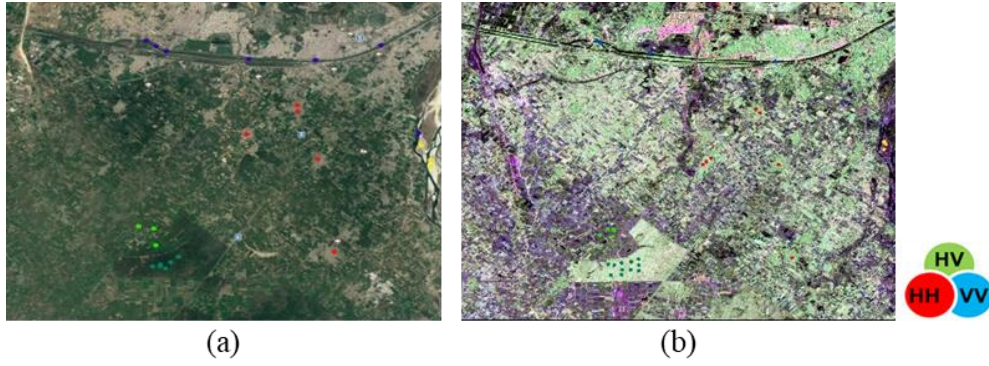

236

237

238

**Figure 3.** (a): Imagery of the Haridwar collected from Google Earth with major land cover classes marked. (b): FCC of the pre-processed March 13, 2015 PolSAR data.

239

240

Table 1 Ground survey details. TV = Tall Vegetation, \*BS =Bare SOIL, SV = Short Vegetation, BU= Built-Up.

LC Class	Roorkee		Haridwar	
	Training	Testing	Training	Testing
Bare Soil (BS)	201	39	201	39
Tall Veg (TV)	201	39	201	39
Short Veg (SV)	201	39	201	39
Built-Up (BU)	201	39	201	39
Water	201	39	201	39
<b>Total</b>	1005	195	1005	195
Total number of villages in Roorkee region	93			
Total number of villages in Haridwar region	60			

241

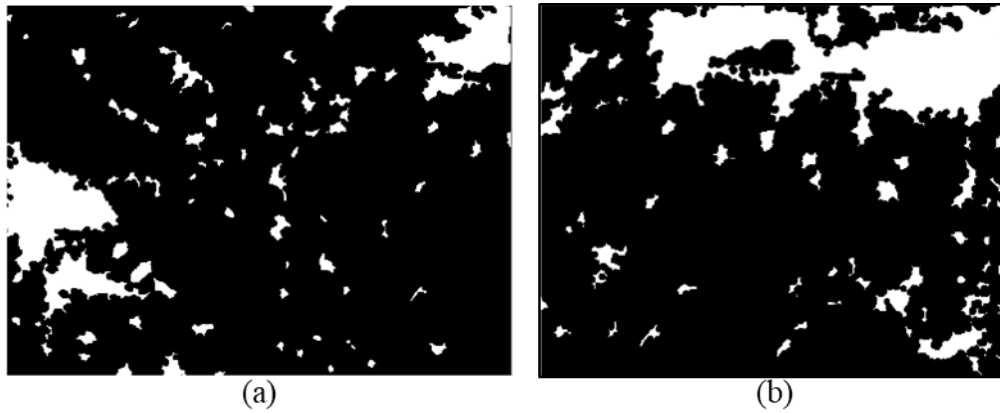

242

243

244

Figure 4. Areas highlighted in white are villages in the (a) Roorkee and, (b) Haridwar study area.

245 **Approach, Results, and Discussion**

246 This section discusses the development of the proposed novel approach to detect, identify, and  
247 map flood affected villages in a PolSAR image. The overall approach is divided into three  
248 stages.

249 In the first stage, design and development of a PSs based CNN model for extraction of  
250 built-up areas from PolSAR image is done. This stage is discussed in sections 4.1 and 4.2. Model  
251 performance evaluation and comparisons are also discussed in section 4.2.

252 In second stage, development of a novel methodology, for designing “village detection  
253 filters” based on *a priori* knowledge and image morphology, is discussed. These filters help in  
254 detection of villages in a ‘built-up’ class image extracted from classification image (stage-1) and  
255 also help suppress false alarms. Section 4.3.1 covers the development of this methodology.  
256 Evaluation of the detection performance of this methodology is also covered in section 4.3.1.

257 Finally, in the third stage, development of methodology, for identification and mapping  
258 of villages that are affected by flood and masking out villages that are not, is discussed. This  
259 methodology exploits the phenomena of ‘enclosed’ that happens when a village is surrounded by  
260 water (flooded from all sides). Section 4.3.2 discusses the development of this methodology.  
261 Evaluation of this methodology is discussed in section 4.3.2. The three methodologies, proposed  
262 in the three stages above, sum up to provide a novel ‘flood affected village detection and  
263 mapping’ approach. Flowchart shown in Figure 5 depicts the overall proposed approach.

264 ***Land Cover Polarization Signatures***

265 Based to the discussion in section 2.1, both co-polarized signatures and cross-polarized  
266 signatures are computed from PolSAR data using equation (1). Co-polarized PS plots for

267 considered land cover class (averaged over all class samples, refer to Table 1) are shown in  
268 Figure 6. Backscatter power response shown in Figure 6 is plotted for orientation angle  $\psi$  range (  
269  $-90^\circ$  degree to  $+90^\circ$ ) degree and ellipticity angle  $\chi$  range ( $-45^\circ$  degree to  $+45^\circ$ ) degree and a step  
270 size of  $5^\circ$  degree in each direction. This results in a  $18 \times 37$  two-dimensional feature space. It is  
271 evident from figure 6 that PSs of considered land covers are different from each other.

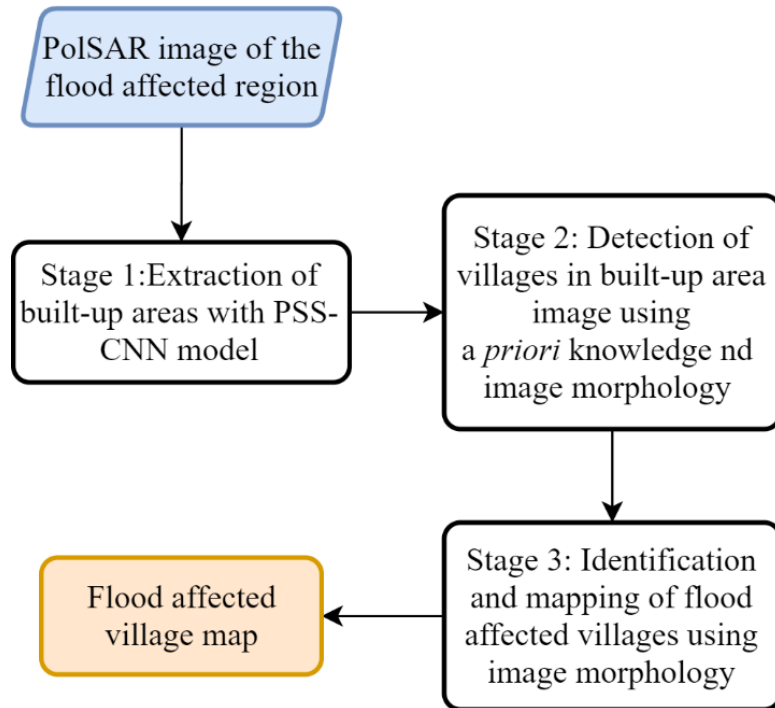

272

273 **Figure 5.**Flowchart of the proposed approach

274



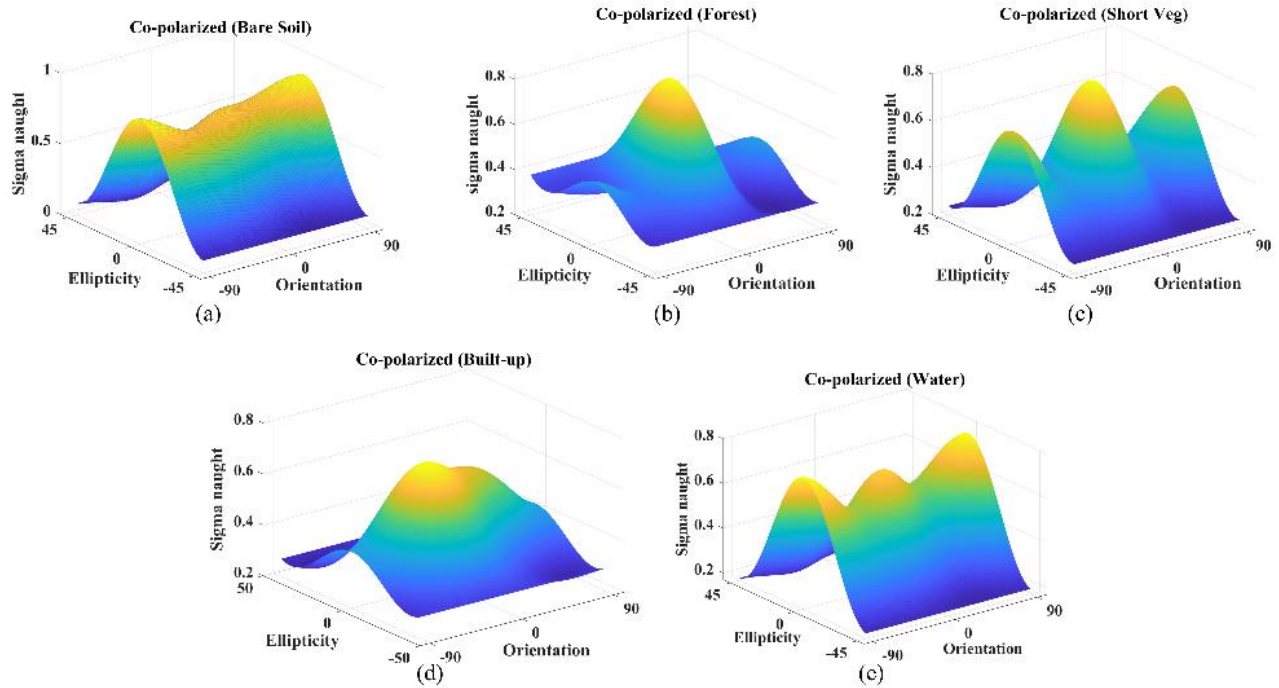

275

276 Figure 6 Land cover class co-polarized PSs. (a). Bare Soil, (b). Forest, (c). Ground Vegetation,  
 277 (d). Built-up, and (e). Water

278 ***Stage 1: PolSig-CNN Classification Model for Built-Up Area Extraction***

279 PSs based features have been used for land cover characterization and classification in many  
 280 studies. Classifiers in (Phartiyal et al., 2017), (Jafari et al., 2015) and (Maurya et al., 2016) used  
 281 PSs based distance/correlation one-dimensional features which do not consider the two-  
 282 dimensional neighbourhood during classification and therefore PSs remain under-utilized.

283 A PSs based CNN classifier is introduced here which explores and extends to more  
 284 effective utilization of PSs directly with CNNs in order to extract built-up areas from PolSAR  
 285 images. In this stage, a CNN model is developed to directly utilize PSs as features for built-up  
 286 area extraction from PolSAR imagery. The proposed CNN model is termed as ‘PolSig-CNN’  
 287 model from here onwards in this paper and, its configuration is provided in Table 2. A two-  
 288 dimensional spatial window of PSs is used as input. The window-based approach, via averaging,

289 helps suppresses the random volume scattering responses generated from closely packed built-up  
290 structures in built-up areas. This in turn improves the segregation of these built-up areas. A  $3 \times 3$   
291 window of neighbouring PSs is considered. This corresponds to a  $54 \times 111$  (refer section 4.1)  
292 matrix/image as input to the PolSig-CNN model. This  $54 \times 111$  input image has two channels i.e.  
293 *copol*, and *crosspol*. Therefore, the overall size of the input to the PolSig-CNN is  $54 \times 111 \times 2$ . The  
294 PolSig-CNN used five convolutional layers and three parallel convolutions with different  
295 dilation rates. The parallel convolutions with varied dilation rates helps to extract localized  
296 polarization feature sub-spaces. This should improve classification performance. The output from  
297 these varied convolutions are finally concatenated before connecting to fully connected layers.  
298 The number of convolution filters and kernel sizes used in each layer are listed in Table 2. *ReLU*  
299 activation function and *Dropout fraction* of 10% is used in each convolutional layer. The dropout  
300 regularization strategy is employed to reduce overfitting and achieve better generalization  
301 (Srivastava et al., 2014). Further, two *Fully Connected* (FC) layers, first with 50 nodes and  
302 second with 10 nodes are used. Both FC layers used the *ReLU* activation function and a *Dropout*  
303 *fraction* of 10%. Finally, a *SoftMax* classification layer with 5 output labels is used. The five  
304 output labels are; built-up (BU), water, bare soil (BS), tall vegetation (TV), and short vegetation  
305 (SV). A *batch normalization* process is carried out before the convolutions to speed up the  
306 training process and to reduce the network sensitivity. Overall, an eight layered PolSig-CNN  
307 classification model is realized as shown in Figure 7.

308 Table 2 Summary of PolSig-CNN model configuration, training and hyperparameter settings. \*F = Filters, K = Kernel size, D =  
 309 Dilation rate

Layer ↓	Nodes						Hyperparameters settings
<b>Input</b> ↓	Input image size = $54 \times 111 \times 2$ , a $3 \times 3$ spatial window with 2 (co- and cross-polarized signatures) Normalization = Batch Normalization						Number of epochs = 200 Learning rate = 0.01 Optimizer = Adam Loss function = Categorical cross entropy
<b>Convolution</b>	<b>F, K, D*</b>	<b>Convolution</b>	<b>F, K, D*</b>	<b>Convolution</b>	<b>F, K, D*</b>	<b>Activation, DF</b>	
C-1-1	10, $9 \times 13$ , $1 \times 1$	C-1-2	10, $5 \times 6$ , $9 \times 18$	C-1-3	10, $3 \times 3$ , $18 \times 37$	ReLU, 0.1	
C-2-1	10, $9 \times 13$ , $1 \times 1$	C-2-2	10, $3 \times 3$ , $1 \times 1$	C-2-3	10, $3 \times 3$ , $1 \times 1$		
C-3-1	10, $9 \times 13$ , $1 \times 1$	C-3-2	10, $5 \times 5$ , $1 \times 1$	C-3-3	10, $5 \times 5$ , $1 \times 1$		
C-4-1	15, $15 \times 33$ , $1 \times 1$	C-4-2	15, $5 \times 5$ , $1 \times 1$	C-4-3	15, $5 \times 5$ , $1 \times 1$		
C-5-1	15, $15 \times 33$ , $1 \times 1$	C-5-2	15, $6 \times 15$ , $1 \times 1$	C-5-3	15, $6 \times 15$ , $1 \times 1$		
<b>Fully connected</b>	<b>Filters</b>						
FC1	50						
FC2	10						
Output layer	5						SoftMax

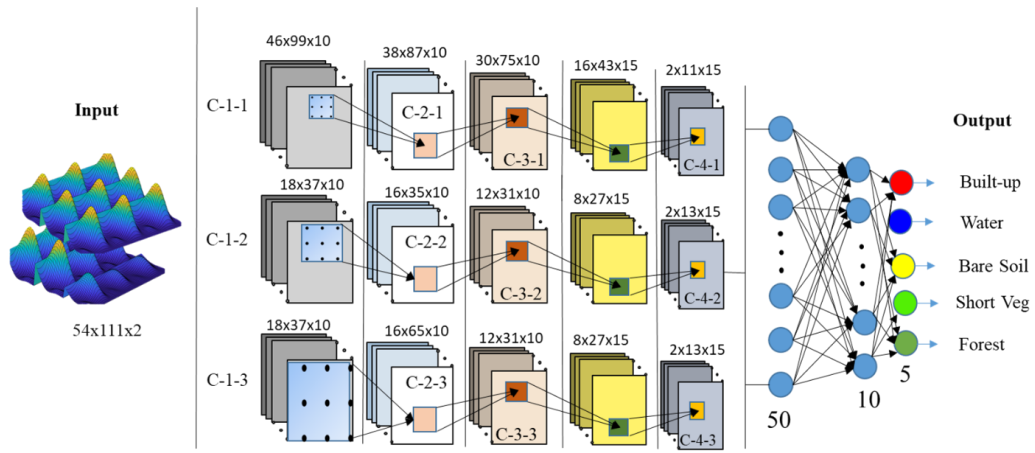

310

311 Figure 7 Architecture of the proposed PolSig-CNN model.

312 The developed PolSig-CNN model is trained on labelled samples collected via ground survey  
 313 (refer Table 1). The choice of loss function during training is the “*categorical cross entropy*”  
 314 function. The *learning rate* is set to 0.01 and the number of training *epochs* is set to 200. For  
 315 network weight optimization, “*Adam*” optimizer is chosen. Model architecture and  
 316 hyperparameters are set similar for Roorkee and Haridwar datasets for consistency purposes and  
 317 are listed in Table 2.

318 Figure 8(a) and figure 8(c) shows the classified image for Roorkee and Haridwar via the  
 319 PolSig-CNN model. The model’s classification performance is compared with two popular  
 320 feature-classifier pairs that are mostly used with PSs in land cover classification. The first is the  
 321 normalized signature correlation mapper (NSCM) feature with maximum value classifier and the  
 322 second is the normalized Euclidean distance (NED) feature with minimum distance classifier.  
 323 Signature correlation mapper or SCM is a cross correlogram constructed by calculating the  
 324 cross-correlation between two polarimetric signatures. The SCM obtained from the Pearson  
 325 correlation coefficient and varies from  $-1$  to  $1$ . The SCM between two signatures  $p_1$  and  $p_2$  is  
 326 given by equation (3).

$$327 \quad S(p_1, p_2) = \left( \frac{m \sum_1^m p_1 p_2 - \sum_1^m p_1 \sum_1^m p_2}{\sqrt{\left[ m \sum_1^m p_1^2 - \left( \sum_1^m p_1 \right)^2 \right]} \sqrt{\left[ m \sum_1^m p_2^2 - \left( \sum_1^m p_2 \right)^2 \right]}} \right) \quad (3)$$

328 where  $m$  is the number of polarization states (Jafari et al., 2015)(de Carvalho and  
 329 Meneses, 2000). NSCM is obtained by normalizing the range of SCM between 0 and 1 using  
 330 equation (4).

$$331 \quad S_N = 0.5*(S + 1) \quad (4)$$

332 Euclidean distance (ED) is the distance metric which provides a quantitative measure of  
333 the distance between vectors representing the two polarimetric signatures, and it reflects the  
334 dissimilarity between the polarimetric signatures (Gower, 1985) (Jafari et al., 2015). The  
335 Euclidean distance between two signatures  $p_1$  and  $p_2$  is given by equation (5).

$$336 \quad D(p_1, p_2) = \sqrt{\sum_1^m (p_1 - p_2)^2} \quad (5)$$

337 where  $m$  is the number of polarization states. Further, NED is the normalized version of  
338 ED. Both NSCM and NED have been utilized for land cover characterization (Jafari et al., 2015)  
339 and for land cover classification (Maurya et al., 2016).

340 Figure 8(e) and 8(g) shows classified images using the NSCM as features for Roorkee  
341 and Haridwar respectively whereas figure 8(i) and 8(k) shows the classified images using the  
342 NED as features for Roorkee and Haridwar respectively. It is evident from Figure 2, Figure 3,  
343 and Figure 8(a, c, e, g, i, and k) that the PolSig-CNN classifier outperforms the NSCM-max-  
344 correlation classifier and the NED-min-distance classifier on both, the Roorkee, and the  
345 Haridwar datasets. Because of the point-wise operability, the limitation of the NED and NSCM  
346 classifiers (termed in short) to capture and exploit the two-dimensional neighbourhood  
347 relationship of a PS pixel and thereby are not able to efficiently segregate the built-up areas as  
348 also discussed in section 1. The developed PolSig-CNN extracts and utilizes the subtle  
349 differences in the PSs of built-up and forest and successfully separates the two and hence  
350 resolves the issue significantly. It is evident from Figure 8(a) & 8(c) that PolSig-CNN classifier  
351 is successful in segregating the two classes. Built-up class is extracted from the PolSig-CNN,  
352 NSCM, and NED classified images of and are shown in Figure 8 (b, d, f, h, j and, l). From Figure

353 8 (b, d, f, h, j and, l), it is evident that the PolSig-CNN is able to segregate the built-up class very  
354 efficiently.

355 Table 3 summarizes the quantitative assessment of classification performance of the  
356 PolSig-CNN, NSCM, and NED classifiers for Roorkee and Haridwar datasets. The PolSig-CNN  
357 classifier performs land cover classification with good overall accuracies, i.e. 72% for Roorkee  
358 and 75.5% for Haridwar dataset. In contrast, the NED performed the classification with 62.5 %  
359 and 59.5% overall accuracy and, the NSCM performed the classification with 64% and 66%  
360 overall accuracy for the Roorkee and Haridwar dataset respectively. Both NED and NSCM  
361 showed low kappa values (refer table 3) whereas the kappa for PolSig-CNN is satisfactory.  
362 Furthermore, the PolSig-CNN classifier successfully segregates the built-up class. The built-up  
363 class is segregated with 83.7% user and 77.5% producer accuracies for Roorkee and 82.5% user  
364 and 82.5% producer accuracies for Haridwar which supports the visual interpretations.

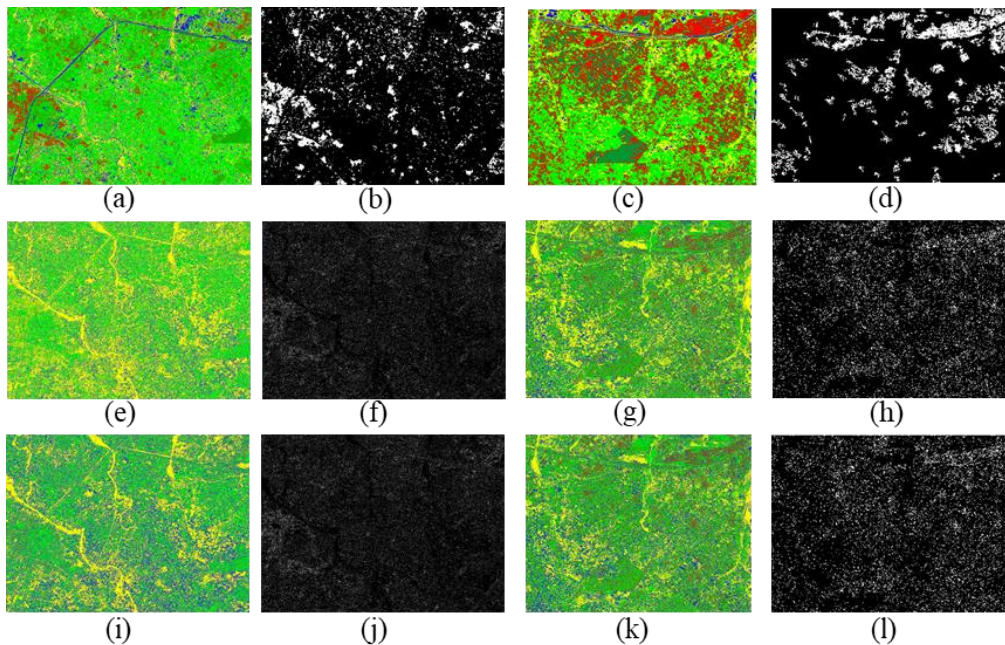

365  
366 Figure 8. Roorkee classified image obtained using; (a). the PolSig-CNN classifier, (e). the NED  
367 classifier and, (i); the NSCM classifier. Areas classified as Built-up in Roorkee dataset using;

368 (b). the PolSig-CNN classifier, (f). the NED classifier and, (j). the NSCM classifier. Haridwar  
 369 classified image obtained using; (c). the PolSig-CNN classifier, (g). the NED classifier and, (k);  
 370 the NSCM classifier. Areas classified as Built-up in Haridwar dataset using; (d). the PolSig-CNN  
 371 classifier, (h). the NED classifier and, (l). the NSCM classifier.

372 Table 3 Summary of the classification performance of classifiers for Roorkee and Haridwar  
 373 datasets. OA = overall accuracy, UA = user accuracy, PA = producer accuracy

<b>Dataset/Study area</b>	<b>Method</b>	<b>OA (%)</b>	<b>Kappa</b>	<b>Class</b>	<b>UA (%)</b>	<b>PA (%)</b>
Roorkee	PolSig-CNN	72.0	0.69	BS	65.91	72.5
				TV	84.21	80
				SV	56.00	70
				BU	83.78	77.5
				Water	77.42	60
	NSCM	64.0	0.57	BS	59.18	72.5
				TV	72.73	60.0
				SV	50.00	70.0
				BU	75.76	62.5
				Water	75.86	55.0
	NED	62.5	0.53	BS	57.45	69.2
				TV	70.59	60.0
				SV	48.21	67.5
				BU	78.13	62.5
				Water	73.33	55.0
Haridwar	PolSig-CNN	75.5	0.72	BS	65.9	72.5
				TV	75.6	77.5
				SV	72.2	65.5
				BU	82.5	82.5
				Water	82.0	80.5
	NSCM	66.0	0.58	BS	65.9	72.5
				TV	72.9	67.5
				SV	48.1	65.0
				BU	75.8	55.0
				Water	77.7	70.0
	NED	59.5	0.52	BS	54.17	66.6
				TV	70.59	60.0
				SV	45.00	67.5
				BU	75.86	55.0
				Water	71.43	50.0



374 *Detection and Mapping of Flood Affected Villages using Apriori Knowledge and Image*  
375 *Morphology*

376 This section presents post classification methodologies based on *apriori* knowledge and image  
377 morphology to map the villages affected by flood. Flood affected village maps are obtained  
378 using the built-up area image obtained in stage 1. This section covers stage 2 and stage 3 of the  
379 proposed approach. The methodology presented under stage 2 detects villages in the built-up  
380 area image from section 4.2. This methodology utilizes *apriori* knowledge and image  
381 morphology to build village detection filters. Binary morphological image processing is well  
382 suited in this case because of the type of outputs produced in stage 1 and the suitability of  
383 morphological operations to operate on this data (Zou et al., 2020). These filters detect villages  
384 in the built-up area image and significantly remove false alarms or misclassifications.  
385 Development of this methodology is discussed under stage 2 in section 4.3.1.

386 Stage 3 presents a methodology which further identifies and maps villages that are  
387 affected by flood and mask out villages that are not affected by flood from the total villages  
388 detected in stage 2. This methodology also utilizes image morphology to map flood affected  
389 villages. Development of this methodology is discussed in section 4.3.2.

390 *Stage 2: Village Detection*

391 The focus of this stage is to detect villages in the built-up area image obtained in stage 1 (refer  
392 section 4.2). Here, at first, the built-up area image — a binary image— is cleaned before detection  
393 because the image might contain objects (built-up areas) that are close to each other and could be  
394 part of same village or, there might be objects with holes in them which is undesirable. These  
395 artefacts could lead to inaccurate detection of villages. Therefore, a series of morphological  
396 operations are utilized to clean the binary image. The objects or components which are close to

397 each other, are merged together at first using a morphological image *closing* filter provided in  
398 equation (6).

$$399 \quad \mathbf{I}_{\text{closed}} = (\mathbf{I} \oplus \mathbf{S}) \ominus \mathbf{S} \quad (6)$$

400 where,  $\mathbf{I}_{\text{closed}}$  is the closed image,  $\mathbf{I}$  is the image on which the morphological closing  
401 operation is to be performed,  $\mathbf{S}$  is the structuring element used in the closing operation, and  $\oplus$  &  
402  $\ominus$  represents the morphological dilation and erosion operations respectively. The vicinity, within  
403 which two objects can be merged together is set via the size of the structuring element parameter.  
404 The vicinity is set based on an *apriori* knowledge of the approximate minimum distance between  
405 two villages and PolSAR image pixel resolution.

406 The approximate minimum distance between two villages is set to 200 meters based on  
407 ground surveys, geographical metadata. Since, the ALOS PALSAR-2 PolSAR data considered in  
408 this study has 6-meter spatial resolution. Therefore,  $\mathbf{S}$  is set as a disc of 15 pixels' diameter (100  
409 meters) and two objects within this distance are merged as one. However, similar relationship  
410 can be modelled with other PolSAR imagery. Figure 9(b) depicts the effects of closing operation.  
411 It can be observed from figure 9(b) that some objects are merged together.

412 Next, the holes in the objects in the  $\mathbf{I}_{\text{closed}}$  image are to be filled. The holes are filled  
413 using equation (7).

$$414 \quad \mathbf{I}_{\text{filled}} = \mathbf{I}_{\text{closed}} \cup \mathbf{X}_k \quad (7)$$

415 where,  $\mathbf{I}_{\text{filled}}$  is the image with holes filled,  $\mathbf{I}_{\text{closed}}$  is the image with holes obtained from  
 416 equation (6),  $\cup$  is the *union* operator, and  $\mathbf{X}_k$  is obtained through iterative process governed by  
 417 equation (8),

$$418 \quad \mathbf{X}_k = (\mathbf{X}_{k-1} \oplus S) \cap \mathbf{I}_{\text{complement}} \quad (8)$$

419 where again,  $\mathbf{X}_0$  is the  $\mathbf{I}_{\text{closed}}$  image,  $S$  is the connectivity and,  $\mathbf{I}_{\text{complement}}$  is the  
 420 negative of  $\mathbf{I}_{\text{closed}}$ . Figure 9(c) depicts the result of the hole filling operation.

421 Finally, an area limit is set to filter out objects that are not villages. The idea is that if any  
 422 object is to be a village, it must have at least 5000 m<sup>2</sup> of ground area. The area limit is established  
 423 based on *a priori* knowledge of the Indian rural human settlements. An area limit ( $A_L$ ) of 5000  
 424 m<sup>2</sup> (140 pixels approx. in case of PALSAR-2 image considered here) is set. Equation (9)  
 425 demonstrates the process of filtering objects based on its area.

$$426 \quad (O_k)_{\text{filtered}} = \begin{cases} 1 & \text{if } (O_k)_{\text{filled}} > A_L \\ 0 & \text{if } (O_k)_{\text{filled}} < A_L \end{cases} \text{ for } k = 1, 2, \dots, N \quad (9)$$

427 where,  $(O_k)_{\text{filtered}}$  is the  $k^{\text{th}}$  object in the filtered image and  $(O_k)_{\text{filled}}$  is the  $k^{\text{th}}$  object in  
 428 the  $\mathbf{I}_{\text{filled}}$  image,  $A_L$  is the area limit and,  $N$  is the total number of objects in  $\mathbf{I}_{\text{filled}}$  image.  
 429 Figure 9(d) depicts output of the area-based filtering. It is observed from Figure 9(d) that many  
 430 unwanted objects have been removed successfully. The objects remained in the filtered image  
 431 are successfully detected as villages. In summary, the closing, hole filling, and the area filter

432 operations in sequence act as a ‘village detection filter’ which detects villages in a built-up area  
433 image and mask out false alarms or misclassifications.

434 This village detection filter is applied to the built-up area images of the PolSig-CNN,  
435 NSCM, and NED. Output images after applying the village detection filter are shown in Figure  
436 10. These output image(s) contain only the successfully *detected villages* and are termed as  
437 “DV” image(s) hereafter in this article. The DV images corresponding to the PolSig-CNN,  
438 NSCM, and NED classifiers are assessed using reference images. The reference images contain  
439 all the villages in the corresponding study areas. The reference images for both Roorkee and  
440 Haridwar are provided in section 3.3. Figure 10 shows false colour composites (FCC) of the DV  
441 images for Roorkee and Haridwar areas. In Figure 10(a), red colour objects are objects in  
442 reference image (actual villages), green colour objects are villages as per the  $DV_{\text{PolSig-CNN}}$ , and  
443 blue colour objects are villages as per the  $DV_{\text{NED}}$ .

444 Further, white colour objects are objects which are present in all three images i.e. the  
445 reference image, the  $DV_{\text{PolSig-CNN}}$  image, and the  $DV_{\text{NED}}$  image. It means that the object is  
446 actually a village and is correctly extracted by both, the PolSig-CNN and the NED classifiers.  
447 Yellow colour objects are villages as per the reference and the PolSig-CNN but not as per the  
448 NED. Cyan colour objects are villages as per the reference and the NED but not as per the  
449 PolSig-CNN. The abundance of yellow colour in Figure 10(a) indicates to the efficient extraction  
450 of built-up areas by the PolSig-CNN classifier. Similarly, the  $\text{reference-D}V_{\text{PolSig-CNN}}-\text{D}V_{\text{NSCM}}$   
451 false colour composite for Roorkee shown in Figure 10(c) evidences the better performance of  
452 the proposed PolSig-CNN classifier in built-up area extraction.

453 However, the reference- $D V_{\text{PoISig-CNN}} - D V_{\text{NED}}$  and the reference- $D V_{\text{PoISig-CNN}} - D V_{\text{NSCM}}$  false  
 454 colour composites for Haridwar in figure 10(b) and figure 10(d) show numerous green colour  
 455 objects. These objects are falsely detected as villages as per PoISig-CNN and indicate false  
 456 alarms. A quantitative analysis is therefore required to assess the performance of the classifiers  
 457 in more detail.

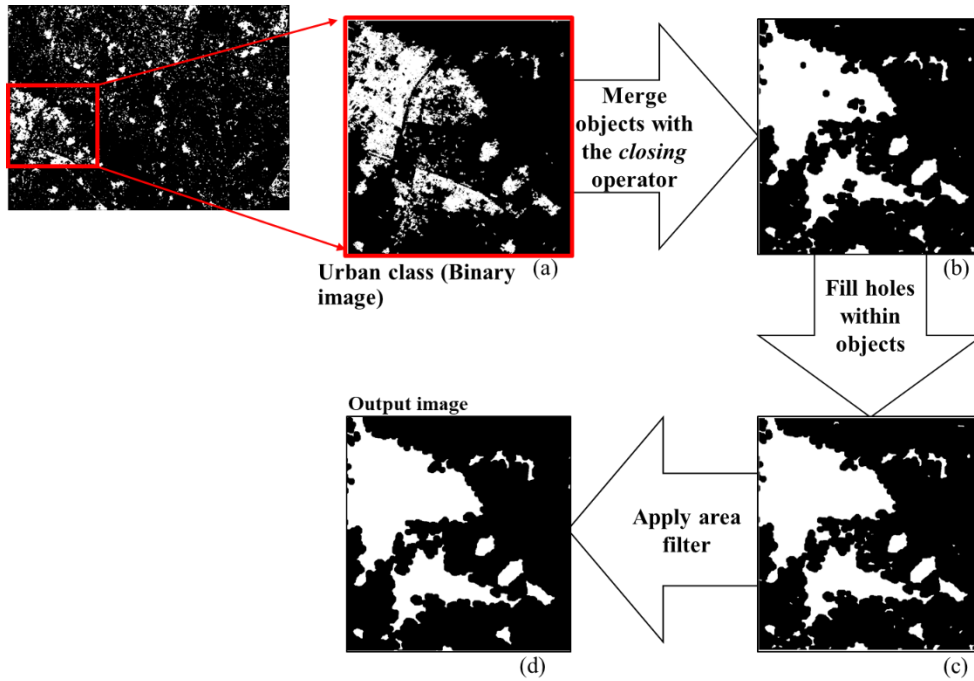

458  
 459 Figure 9 (a). Segment of image shown in figure 6(a). Corresponding segments of: (b). Image  
 460 after the *closing* operation, (c) Image after the *holes filling* operation and, (d). image after the  
 461 *filtering* operation

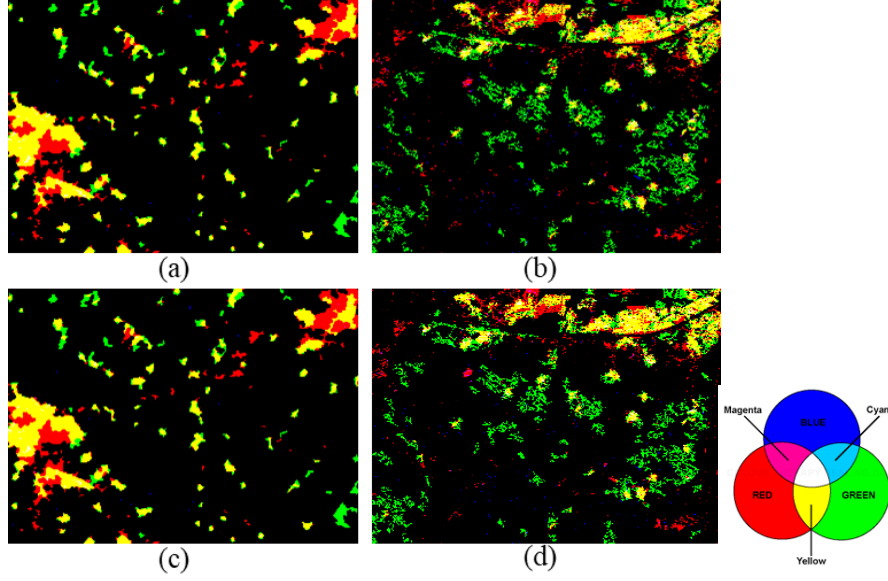

462

463 Figure 10 (a) False colour composites for Roorkee using

464 red = reference, green =  $DV_{\text{PolSig-CNN}}$ , blue =  $DV_{\text{NED}}$  colour scheme, (b) False colour composites for

465 Haridwar using red = reference, green =  $DV_{\text{PolSig-CNN}}$ , blue =  $DV_{\text{NED}}$  colour scheme, (c) False colour

466 composites for Roorkee using red = reference, green =  $DV_{\text{PolSig-CNN}}$ , blue =  $DV_{\text{NSCM}}$  colour scheme,

467 and (d) False colour composites for Haridwar using

468 red = reference, green =  $DV_{\text{PolSig-CNN}}$ , blue =  $DV_{\text{NSCM}}$  colour scheme.

469 For quantitative evaluation of the DV images corresponding to the PolSig-CNN, NSCM, and

470 NED classifiers, the following method is considered. At first, a bounding box to mark the extent

471 of each object in both; the reference and the test image, is computed. Then, a bounding box

472 overlap ratio (BBOR) is computed using equation (10) for each pair of objects in the reference

473 and the test image. Test image here represents the ‘image under test’ which is the DV image

474 from the classifiers.

475

$$(\text{BBOR}) = \frac{(\text{Overlap Area})_{(\text{test}, \text{reference})}}{\min((\text{Bounding Box Area})_{\text{reference}}, (\text{Bounding Box Area})_{\text{test}})} \quad (10)$$

476 If the BBOR of a particular object pair is above a predefined threshold, then the  
 477 corresponding object in the test image is counted a successful detection, otherwise not. The  
 478 threshold is set to 0.5 based on experiment and is set identical for both Roorkee and Haridwar  
 479 study areas for consistency purpose.

480 True positives (successfully detected villages), true negatives (villages missed), and false  
 481 alarms or false positives (objects detected as villages in the test image but are actually not) are  
 482 computed using equation (11) through (14).

$$483 \quad \text{True Positive (TP)} = \sum_{i=1}^m \text{logical}(\text{IOU}_i > \text{threshold}) \quad (11)$$

484 Where, m is the total number of objects (villages) in the reference image, and

$$485 \quad \text{logical}(x) = \begin{cases} 1 & \text{if } x > \text{threshold} \\ 0 & \text{if } x < \text{threshold} \end{cases} \quad (12)$$

$$486 \quad \text{False Negative (TN)} = \text{Total number of villages in reference image} - \text{TP} \quad (13)$$

$$487 \quad \text{False Positive (FP)} = \text{Total number of objects in test image} - \text{TP} \quad (14)$$

488 True positives (TP), False negatives (FN), false positives (FP), and intersection over  
 489 union (IoU) are computed for Roorkee and Haridwar study areas for PolSig-CNN, NED, and  
 490 NSCM. Table 4 summarizes the quantities assessment of the DV images of the PolSig-CNN,  
 491 NED, and NSCM classifiers. The PolSig-CNN successfully extracts 75 (out of 93) villages in the  
 492 Roorkee study area and 47 (out of 60) villages in the Haridwar study area. Whereas, NED  
 493 successfully extracts 26 villages in Roorkee and 20 villages in Haridwar and, NSCM  
 494 successfully extracts 22 villages in Roorkee and 27 villages in Haridwar. The low detection rate

495 in case of the NED and the NSCM resonates with their low classification accuracies for built-up  
 496 class (refer table 2).

497 The false alarms are also high for the NED and the NSCM. The low values of kappa for  
 498 NED and NSCM (refer table 2) indicate to the high false alarms. The PolSig-CNN offers higher  
 499 detection rate and low false alarms for both Roorkee and Haridwar study areas.

500 Table 4 Summary of quantitative assessment of performance of PolSig-CNN, NED, and NSCM.

Dataset	Measures	NED	NSCM	PolSig-CNN
<b>Roorkee</b>	Total number of villages in the study area	93	93	93
	TP (Villages successfully mapped)	26	22	75
	FN (Villages missed)	67	71	18
	FP ( or False Alarms)	31	41	1
	IoU	<b>0.22</b>	<b>0.16</b>	<b>0.98</b>
<b>Haridwar</b>	Total number of villages in the study area	60	60	60
	TP (Villages successfully mapped)	20	27	47
	FN (Villages missed)	40	33	13
	FP (or False Alarms)	33	39	5
	IoU	<b>0.21</b>	<b>0.22</b>	<b>0.92</b>

501

502 *Stage 3: Mapping flood affected villages*

503 Since, any PolSAR image acquired to monitor a flood may include both, flooded and not flooded  
 504 regions. Therefore, it is important here to identify flood affected villages and mask-out non-  
 505 flooded villages since the result may impact the planning of a rescue operation. A separate  
 506 (stage-3) methodology is proposed to achieve this task. The methodology presented in this  
 507 section encompasses stage 3 of the overall approach.

508 Intuitively, the villages that are flooded must be completely enclosed by water and  
 509 villages that are not completely flooded should not be enclosed by water. It means that any  
 510 village that is completely flooded should appear as ‘hole’ in the ‘water’ class image and any  
 511 village that is not completely affected by flood should not appear as a hole and may have



512 presence of other class in the vicinity. Based on this interpretation, a criterion is set i.e. if an  
513 object in the DV image obtained from section 4.3.1 is a subset of an object in the water class  
514 image, then, that object in the DV image is a flooded village otherwise it is a non-flooded  
515 village. This criterion separates flooded villages from non-flooded villages.

516 To realize this criterion, intersection is computed over DV image and the “holes filled”  
517 version of water class image. The holes-filled water class image is obtained using equation  
518 similar to equation (7). Objects remaining in the intersection image are flooded villages and  
519 remaining objects in the DV image is not a completely flooded village. The flowchart of the  
520 methodology is depicted in figure 11.

521 In order to evaluate this methodology, three different ‘artificial flood’ scenarios are  
522 created. The three flood scenarios are shown in figure 12(a-c). In the first scenario as shown in  
523 figure 12(a), flood (highlighted in blue) has affected the whole study region whereas in the  
524 second and third scenarios, flood has affected some parts of the study region. For experiment, the  
525 DV image of Haridwar corresponding to the PolSig-CNN (refer figure 10(b)) is subjected to  
526 these three flood scenarios as shown in figure 12(a-c).

527 In figure 13(a-c), the flood affected villages are marked with yellow colour and the non-  
528 flooded villages are marked with red colour. It is evident from figure 13(a-c) that the  
529 methodology proposed in this section successfully identifies and maps villages that are  
530 completely affected by flood and masks out villages that are not affected by flood. Although, this  
531 methodology includes the step ‘generation of artificial flood scenarios’, however, in real flood  
532 situation, this step is skipped and flooded villages can be directly be mapped. The methodology  
533 is also evaluated on real flood scenario and results are highlighted in section 4.4.

534 Overall, two methodologies are proposed in section 4.3. The stage-2 methodology detects  
 535 villages and removes false alarms and misclassifications in a built-up area image. The stage-3  
 536 methodology maps flooded villages and masks out non-flooded villages. These two  
 537 methodologies in combination with the PolSig-CNN classifier completes the novel ‘flood  
 538 affected village detection and mapping’ approach.

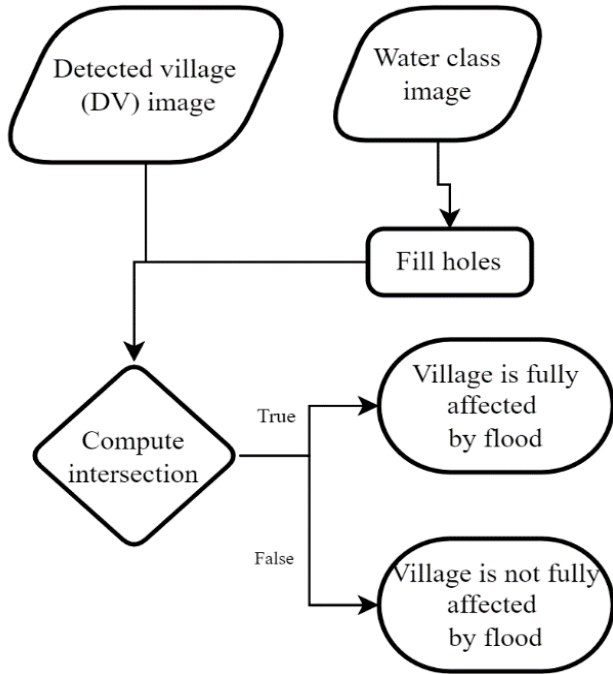

539  
 540 Figure 11 Stage 3 methodology flowchart for flood affected village detection.

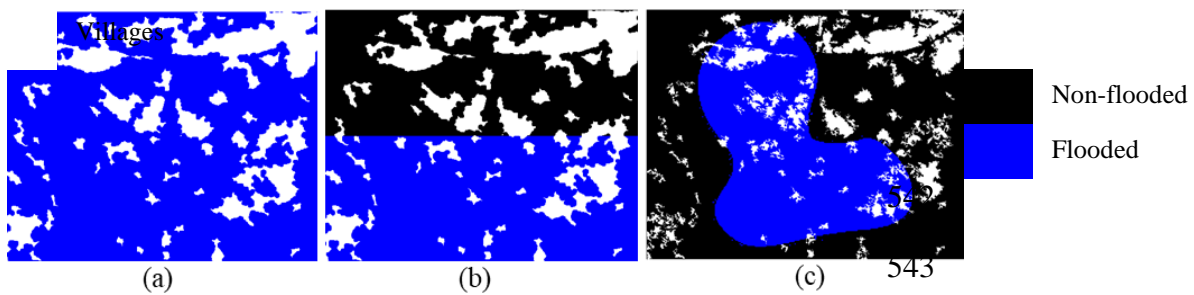

544 Figure 12 Different artificial flood scenarios; (a) Flood scenario 1, (b) Flood scenario 2 and, (c)  
 545 Flood scenario 3.

546

547

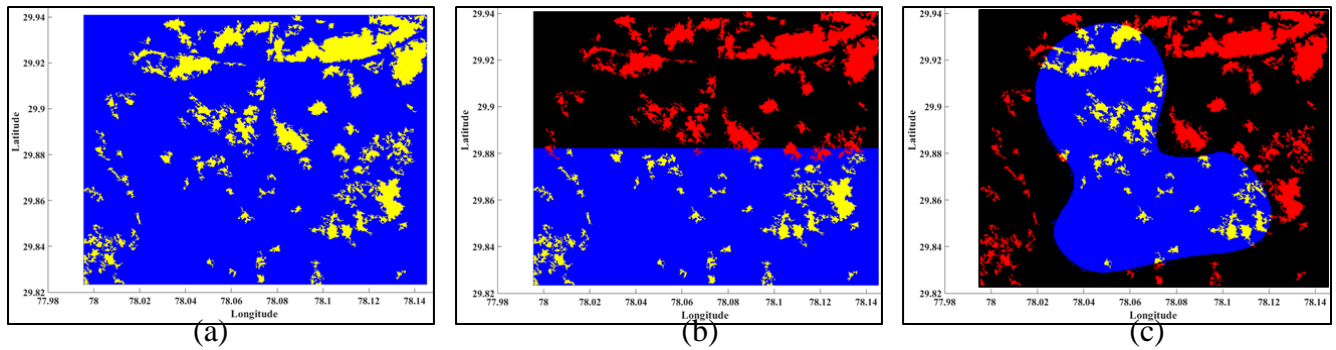

548 Figure 13 Flood affected villages (in yellow) and non-flooded villages (in red) under; f(a) Flood  
549 scenario 1. (b) Flood scenario 2. (c) Flood scenario 3. Colour scheme: yellow = villages affected  
550 by flood, red = non-flooded villages and, blue = flooded region.

### 551 *Validation on real flood scenario*

552 The novel approach proposed in section 4 is validated on real flood PolSAR dataset of Patna,  
553 Bihar, India from August 2016. Patna, Bihar sits up at the banks of the river Ganges. The August  
554 2016 Bihar flood affected Patna and neighbouring regions along with other parts of the state.  
555 Figure 14(c) shows the FCC of the PALSAR-2 PolSAR data acquired over Patna region on  
556 September 03, 2016. The figure clearly highlights the flooded region. The PolSig-CNN classifier  
557 used this dataset to create the classification image shown in figure 14(d). The classified image  
558 reflects to the flooded situation with presence of ‘water’ class extensively in the area. Further,  
559 ‘built-up’ class is extracted using stage-2 methodology from the classified image and is shown in  
560 figure 14(e). The resulting image is termed as detected-village (DV) image. It is observed that  
561 villages in the area are successfully extracted (both flooded and non-flooded). Finally, flood  
562 affected villages are mapped using stage-3 methodology and are highlighted with yellow colour  
563 in figure 14(f). The final result indicates to the efficiency and effectiveness of the proposed  
564 approach in detection and mapping flooded villages using PolSAR data.

565 **Conclusion**

566 This paper presented an efficient approach to map flood affected villages using fully polarimetric  
567 SAR imagery. The approach included three stages i.e. –*stage 1*, built-up area extraction, –*stage*  
568 2, village detection and, –*stage 3*, flood affected village mapping.

569 In the first stage, the approach utilized PALSAR-2 PolSAR polarization signatures (PSs)  
570 two-dimensional features and dilated convolutions based CNNs to extract built-up areas. A novel  
571 five-class classifier namely PolSig-CNN is developed and trained on 3X3 window PSs class  
572 samples, the dilated convolutions based CNN classifier provided improved built-up area  
573 extraction because of its ability to capture the two-dimensional neighbourhood relationship of a  
574 PS pixel. Quantitative results indicate to approx. 83% classification accuracy for built-up  
575 averaged over two different study areas which is promising.

576 In the second stage, a novel village detection methodology is developed. The  
577 methodology detects whether a particular object in the built-up area image, obtained from stage  
578 1, is a village or not using a village detection filter. The detection filter is built on *a priori*  
579 knowledge on the minimum average size of rural human settlements in India and image  
580 morphology. The detection methodology also significantly removed false alarms and false  
581 negatives. A strong detection accuracy of 80% is achieved with this methodology. Qualitative  
582 results are also in agreement with the performance.

583 In the third and final stage, flood affected villages are identified and non-flooded villages  
584 are masked out using another image morphology-based methodology. This stage-3 mapping  
585 methodology computes a degree-of-intersection between successfully detected villages and  
586 flooded area masks and utilizes it for identification of flood affected villages. Experiments are  
587 conducted on simulated and real flood datasets and performance of the three-stage approach is

588 satisfactory. An average detection accuracy of approx. 80% and further, mapping accuracy of  
589 100% is achieved over different study areas. In summary, the three-stage novel approach  
590 presented here successfully detects and maps flood affected villages with the help of a PolSAR  
591 image. The approach indicates potential to be tested at a real-time.

## 592 **Acknowledgements**

593 *Data:* Authors would like to thank JAXA, Japan for providing the ALOS-2 PALSAR-2 dataset. Authors  
594 would like to thank IIRS, Dehradun, India for supporting this work. Authors would also like to thank all  
595 the lab members of MISTAL, IIT Roorkee for their support.

## 596 **Declaration of Interest Statement**

597 The authors declare that authors have no conflict of interest.

## 598 **Data Availability Statement**

599 lab, Availability of the data is subjected to be used exclusively uunder the affiliation of Prof.  
600 Dharmendra Singh, ECE Department, IIT Roorkee. Collaborations are invited to use the data for  
601 impactful studies.

602 **Word Count: 8562**

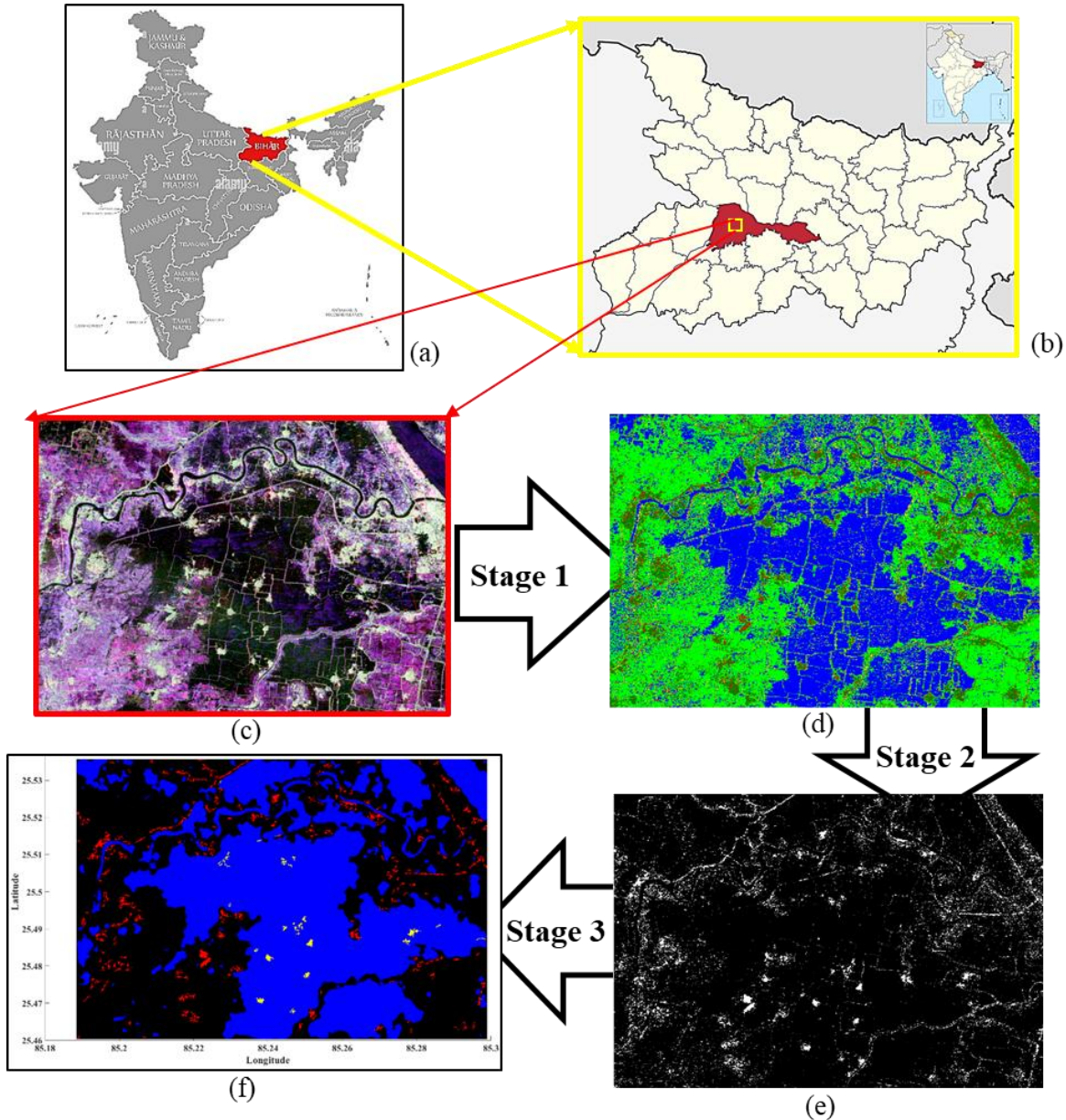

604

605 Figure 14 Validation of the proposed approach. (a) India's state administrative boundaries  
 606 illustration with Bihar highlighted in red, (b) Bihar's district administrative boundaries  
 607 illustration with Patna highlighted in red and study area demarcated with yellow box, (c) False  
 608 color composite (red = HH, green = HV, and blue = VV) PALSAR-2 PolSAR imagery of the  
 609 validation study area, (d) Classification image using the PolSig-CNN classifier proposed in  
 610 stage-1, (e) Villages extracted (DV image) using stage-2 methodology, and (f) Flood affected  
 611 villages (highlighted in yellow) using stage-3 methodology.

612 **References**

- 613 Antenna Laboratory, D. of E.E., 1952. Effects of Type of Polarization on Echo  
614 Characteristics. Columbus, Ohio. <https://doi.org/10.1002/nav.3800080206>
- 615 Bielecka, M., Porzycka-Strzelczyk, S., Strzelczyk, J., 2014. SAR Images Analysis based on  
616 Polarimetric Signatures. *Applied Soft Computing Journal* 23, 259–269.  
617 <https://doi.org/10.1016/j.asoc.2014.06.013>
- 618 Ciresan, D., Meier, U., Schmidhuber, J., 2012. Multi-column Deep Neural Networks for  
619 Image Classification, in: *IEEE Conference on Computer Vision and Pattern*  
620 *Recognition, CVPR*. IEEE, Rhode Islan, USA, pp. 3642–3649.  
621 <https://doi.org/10.1109/CVPR.2012.6248110>
- 622 Dasgupta A., Grimaldi S., Ramakrishnan R., Walker J. P., 2017. Optimized GLCM-based  
623 Texture Features for Improved SAR-based Flood Mapping, in: *Geoscience and*  
624 *Remote Sensing Symposium*. IEEE, Texas, USA, pp. 3258–3261.
- 625 de Carvalho, O.A., Meneses, P.R., 2000. Spectral Correlation Mapper (SCM): An  
626 Improvement on the Spectral Angle Mapper (SAM), in: *Summaries of the 9th JPL*  
627 *Airborne Earth Science Workshop*. JPL Publication, Pasadena, CA, 2000.
- 628 Dumitru, C.O., Cui, S., Faur, D., Datcu, M., 2015. Data analytics for rapid mapping: Case  
629 study of a flooding event in Germany and the tsunami in Japan using very high  
630 resolution SAR images. *IEEE J Sel Top Appl Earth Obs Remote Sens* 8, 114–129.  
631 <https://doi.org/10.1109/JSTARS.2014.2320777>
- 632 Fukushima, K., Miyake, S., 1982. Neocognitron: A Self-Organizing Neural Network Model  
633 for a Mechanism of Visual Pattern Recognition, in: *Competition and Cooperation in*  
634 *Neural Nets*. Springer, Berlin, Heidelberg., pp. 267–285.
- 635 Garg, A., Singh, D., 2018. Development of an Efficient Contextual Algorithm for  
636 Discrimination of Tall Vegetation and Urban for PALSAR Data. *IEEE Transactions*  
637 *on Geoscience and Remote Sensing* 56, 3413–3420.  
638 <https://doi.org/10.1109/TGRS.2018.2799639>
- 639 Giustarini, L., Hostache, R., Matgen, P., Schumann, G.J.P., Bates, P.D., Mason, D.C., 2013.  
640 A Change Detection Approach to Flood Mapping in Urban Areas using TerraSAR-  
641 X. *IEEE Transactions on Geoscience and Remote Sensing* 51, 2417–2430.  
642 <https://doi.org/10.1109/TGRS.2012.2210901>

643 Gower, J.C., 1985. Properties of Euclidean and non-Euclidean Distance Matrices. *Linear*  
644 *Algebra Appl* 67, 81–97. [https://doi.org/10.1016/0024-3795\(85\)90187-9](https://doi.org/10.1016/0024-3795(85)90187-9)

645 Harold, M., 2007. The Kennaugh Matrix, in: *Remote Sensing with Polarimetric Radar*. John  
646 Wiley & Sons, New Jersey, pp. 295–298.

647 Ian Goodfellow, Bengio, Y., Courville, A., 2017. Deep learning, *Nature Methods*.  
648 <https://doi.org/10.1038/nmeth.3707>

649 Jafari, M., Maghsoudi, Y., Zoej, M.J.V., 2015. A New Method for Land Cover  
650 Characterization and Classification of Polarimetric SAR Data Using Polarimetric  
651 Signatures. *IEEE J Sel Top Appl Earth Obs Remote Sens*.  
652 <https://doi.org/10.1109/jstars.2014.2387374>

653 Jong-Sen Lee, Mitchell R. Grunes, Wolfgang-Martin Boerner, 1997. Polarimetric Property  
654 Preservation in SAR Speckle Filtering, in: Harold Mott (Ed.), *Proc. SPIE 3120*,  
655 *Wideband Interferometric Sensing and Imaging Polarimetry*. SPIE, San Diego, pp.  
656 1–7. <https://doi.org/10.1117/12.300624>

657 Kennaugh, E., Sloan, R., 1952. Effects of type of polarization on echo characteristics.  
658 Columbus, Ohio.

659 LeCun, Y., Bottou, L., Bengio, Y., Haffner, P., 1998. Gradient-based learning applied to  
660 document recognition. *Proceedings of the IEEE* 86, 2278–2323.  
661 <https://doi.org/10.1109/5.726791>

662 Manavalan, R., Rao, Y.S., Krishna Mohan, B., Venkataraman, G., Chattopadhyay S., 2013.  
663 Landuse / Landcover based Flood Area Assessment using L- and C-band SAR Data  
664 of Coastal Region of Andhra Pradesh, India, in: *Conference Proceedings of 2013*  
665 *Asia-Pacific Conference on Synthetic Aperture Radar (APSAR)*. IEICE, Tsukuba,  
666 Japan, pp. 253–256.

667 Martinis, S., Kersten, J., Twele, A., 2015. A fully Automated TerraSAR-X Based Flood  
668 Service. *ISPRS Journal of Photogrammetry and Remote Sensing* 104, 203–212.  
669 <https://doi.org/10.1016/j.isprsjprs.2014.07.014>

670 Maurya, A.K., Phartiyal, G.S., Singh, D., 2016. A Critical Analysis of Polarimetric  
671 Signatures on PALSAR 2 Data for Land Cover Classification, in: Singh, D. (Ed.),  
672 *IEEE International Conference on Industrial and Information Systems*. IEEE,  
673 Roorkee, pp. 920–924. <https://doi.org/10.1109/ICIINFS.2016.8263070>



674 Mishra, P., Garg, A., Singh, D., 2017. Critical Analysis of Model-Based Incoherent  
675 Polarimetric Decomposition Methods and Investigation of Deorientation Effect.  
676 IEEE Transactions on Geoscience and Remote Sensing 55, 4868–4877.  
677 <https://doi.org/10.1109/TGRS.2017.2652060>

678 Phartiyal, G.S., Kumar, K., Singh, D., 2020. An improved land cover classification using  
679 polarization signatures for PALSAR 2 data. Advances in Space Research 65, 2622–  
680 2635. <https://doi.org/10.1016/j.asr.2020.02.028>

681 Phartiyal, G.S., Kumar, K., Singh, D., Singh, K.P., 2017. Optimal Use of Polarimetric  
682 Signature on PALSAR-2 Data for Land Cover Classification, in: International  
683 Geoscience and Remote Sensing Symposium. pp. 4558–4561.  
684 <https://doi.org/10.1109/IGARSS.2017.8128016>

685 Phartiyal, G.S., Singh, D., Brodu, N., Yahia, H., 2019. Improved Utilization of Polsar  
686 Polarization Signatures Using Convolutional-Deep Neural Nets for Land Cover  
687 Classification, in: International Geoscience and Remote Sensing Symposium. IEEE,  
688 pp. 5824–5827. <https://doi.org/10.1109/IGARSS.2019.8899809>

689 Pradhan, B., Tehrany, M.S., Jebur, M.N., 2016. A New Semiautomated Detection Mapping  
690 of Flood Extent from TerraSAR-X Satellite Image Using Rule-Based Classification  
691 and Taguchi Optimization Techniques. IEEE Transactions on Geoscience and  
692 Remote Sensing 54, 4331–4342. <https://doi.org/10.1109/TGRS.2016.2539957>

693 Schnebele, E., Cervone, G., Kumar, S., Waters, N., 2014. Real Time Estimation of the  
694 Calgary Floods Using Limited Remote Sensing Data. Water (Basel) 6, 381–398.  
695 <https://doi.org/10.3390/w6020381>

696 Sharma, R.K., Kumar, B.S., Desai, N.M., Gujraty, V.R., 2008. SAR for Disaster  
697 Management. IEEE Aerospace and Electronic Systems 23, 4–9.  
698 <https://doi.org/10.1109/MAES.2008.4558001>

699 Silvana, G.D., Laura, G., 2018. Adaptive SAR Image Processing Techniques to Support  
700 Flood Monitoring from Earth Observation Data, in: Refice, A., D’Addabbo, A.,  
701 Capolongo, D. (Eds.), Flood Monitoring through Remote Sensing. Springer, Bari,  
702 Italy. <https://doi.org/10.1007/978-3-319-63959-8>

703 Srivastava, N., Hinton, G., Krizhevsky, A., Sutskever, I., Salakhutdinov, R., 2014. Dropout:  
704 A Simple Way to Prevent Neural Networks from Overfitting. *Journal of Machine*  
705 *Learning Research* 15, 1929–1958.

706 van Zyl, J.J., Zebker, H.A., Elachi, C., 1987. Imaging radar polarization signatures: Theory  
707 and observation. *Radio Sci* 22, 529–543. <https://doi.org/10.1029/RS022i004p00529>

708 Yann LeCun, Yoshua Bengio, Geoffrey Hinton, 2015. Deep learning. *Nature* 321, 436–444.  
709 <https://doi.org/10.1038/nature14539>

710 Zhang, W., Hasegawa, A., Itoh, K., Ichioka, Y., 1991. Image Processing of Human Corneal  
711 Endothelium Based on a Learning Network. *Appl Opt* 30, 4211–4217.

712 Zhu, X.X., Tuia, D., Mou, L., Xia, G.-S., Zhang, L., Xu, F., Fraundorfer, F., 2017. Deep  
713 Learning in Remote Sensing: A Comprehensive Review and List of Resources.  
714 *IEEE Geosci Remote Sens Mag* 5, 8-36,.  
715 <https://doi.org/10.1109/MGRS.2017.2762307>

716 Zou, B., Xu, X., Zhang, L., 2020. Object-Based Classification of PolSAR Images Based on  
717 Spatial and Semantic Features. *IEEE J Sel Top Appl Earth Obs Remote Sens* 13,  
718 609–619. <https://doi.org/10.1109/JSTARS.2020.2968966>  
719