



**HAL**  
open science

## Grid Imbalance Prediction Using Particle Swarm Optimization and Neural Networks

Eren Deliaslan, Denizhan Guven, Mehmet Özgür Kayalica, M. Berker Yurtseven

► **To cite this version:**

Eren Deliaslan, Denizhan Guven, Mehmet Özgür Kayalica, M. Berker Yurtseven. Grid Imbalance Prediction Using Particle Swarm Optimization and Neural Networks. IFIP International Workshop on Artificial Intelligence for Knowledge Management (AI4KMES), Aug 2021, Montreal, QC, Canada. pp.87-101, 10.1007/978-3-030-96592-1\_7. hal-04120819

**HAL Id: hal-04120819**

<https://inria.hal.science/hal-04120819v1>

Submitted on 7 Jun 2023

**HAL** is a multi-disciplinary open access archive for the deposit and dissemination of scientific research documents, whether they are published or not. The documents may come from teaching and research institutions in France or abroad, or from public or private research centers.

L'archive ouverte pluridisciplinaire **HAL**, est destinée au dépôt et à la diffusion de documents scientifiques de niveau recherche, publiés ou non, émanant des établissements d'enseignement et de recherche français ou étrangers, des laboratoires publics ou privés.



Distributed under a Creative Commons Attribution 4.0 International License



This document is the original author manuscript of a paper submitted to an IFIP conference proceedings or other IFIP publication by Springer Nature. As such, there may be some differences in the official published version of the paper. Such differences, if any, are usually due to reformatting during preparation for publication or minor corrections made by the author(s) during final proofreading of the publication manuscript.

# Grid Imbalance Prediction Using Particle Swarm Optimization and Neural Networks

Eren Deliaslan<sup>1</sup>[0000-0002-3980-0289], Denizhan Guven<sup>2</sup>[0000-0003-1605-7661],

Mehmet Özgür Kayalica<sup>1</sup>[0000-0001-9828-7385] and M. Berker Yurtseven<sup>1</sup>[0000-0001-6932-2532]

<sup>1</sup> Energy Institute, Istanbul Technical University, Istanbul 34467, Turkey

<sup>2</sup> Eurasia Institute of Earth Sciences, Istanbul Technical University, Istanbul 34467, Turkey

deliaslan19@itu.edu.tr

**Abstract.** Fluctuations in the power demand amounts, supply problems, uncertainty in weather conditions are known to cause power deviations in the real-time power market. The imbalance costs are reflected in the consumer prices in the partly liberated markets of the developing countries. Thus, the accurate short-run forecast of the electricity market trends is beneficial for both the suppliers and the utility companies to constitute a balance between the physical energy supply and commercial revenue. When both day-ahead market and intra-day market exist to respond to the power demand, forecasting the imbalances lead both the suppliers and the regulators. This study aims to optimize the grid imbalance volume prediction by integrating the Particle Swarm Optimization (PSO) and Long Short-Term Memory Recurrent Neural Networks (LSTM). The model is applied for 1 hour, 4-hours, 8-hours, 12-hours and 24-hours ahead. The Mean Absolute Percentage Error (MAPE) is also calculated. As a result, The MAPE levels are found to be 27.41 for 24 hours, 25.66 for 12 hours, 26.77 for 8 hours, 25.39 for 4 hours, 9.25 for 1 hour. Although improvements are foreseen both in the model and data, achievements of this study would reduce the imbalance penalties for the power generators, whereas, the regulators will organize the outages with a precise approach. Hence, the economic benefits will affect the trading prices in the long term.

**Keywords:** Energy Market Balancing, Turkish Power Market, Particle Swarm Optimization and Long Short-Term Memory.

## 1 Introduction

After the mid-1980s, countries have engaged in the energy market reform initiatives, such as liberalization, privatization, and renewable energy technologies. In the power

market, it is essential to set a balance between the energy supply and the energy consumption at any given point in time. However, electricity markets may not always ensure this balance because of the uncertainties in both supply and demand. Furthermore, due to the increasing attention on climate change and global warming, it is aimed to increase the share of Renewable Energy Sources (RES) in the energy mix. Despite the environmental benefits of RES, there are also some concerns about their negative impacts on the electricity markets [1]. Since the electricity generation from RES is dependent on weather conditions, the amount of electricity generation becomes more unpredictable and thus, grid imbalances become much bigger. To minimize or prevent the grid instabilities, the grid imbalances are to be compensated by the Transmission System Operator (TSO) [2]. In this context, Ancillary Services (AS), such as voltage and frequency control are critical to ensure a stable electricity network throughout the transition towards cleaner electricity production technologies [3].

Due to the transition for cleaner electricity generation, both state and private sector investments are continuously growing in Turkey. Thus, the Turkish energy market, which is one of the fastest-growing power markets all over the world, is living through a continuous change [4]. In the new market structure, the intra-day market acts as a balancing mechanism between the day-ahead market and the balancing power market. The Balancing Power Market (BPM) is conducted under the control of the Turkish Electricity Transmission Company (TETC). Although a well-balanced market is exhibited to the system operator (National Load Dispatch Centre-NLDC) within the day-ahead market, deviations arise in real-time.

The objective of this study is both to optimize the grid imbalance prediction by integrating Particle Swarm Optimization (PSO) and Recurrent Neural Networks (RNN) and to try to find an answer to “Is it possible to predict system direction?”. While the PSO technique is a meta-heuristic search method whose mechanics are inspired by the swarming and collaborative behavior of biological populations, RNN is a feed-forward neural network with internal memory. RNN takes into account the current input and output that it has learned from the previous input to make a decision. The first stage is to select the best regressors among the 45 influencers of the day-ahead balancing market using the PSO technique. Following this stage, an LSTM model is utilized to predict the grid imbalance volumes for different forecast horizons.

Predicting the system direction is crucial since the system regulators reflect any imbalance costs to the utility companies which affects the consumer prices. In a way, having the information in advance is highly beneficial for the suppliers. Moreover, market participants minimize how much they lose based on the position in the market with better-predicted values. However, in the literature, there is a very limited number of studies that use the Swarm Optimization (SO) algorithm, and no other study that combines these two methods for the electricity market. This article tries to bring a new perspective for the balancing markets of the developing countries using a novel approach.

This paper is organized as follows. Grid imbalance studies have been reviewed for both modeling and forecasting approaches in Section 2. Section 3 presents brief information about the Turkish electricity market. In the fourth section, the methodology of the study is explained. In the fifth section, results are discussed. Finally, we conclude.

## 2 Literature

Power imbalance prediction is an up-to-date research topic covered in the literature for various power markets in the world. In this context, Sirin and Yilmaz [5] focused on the impact of renewable energy technologies on the Turkish balancing market. They took the generation and market outlook, wholesale electricity market structure and renewable energy policies into consideration. The results of the Quantile Regression model and Ordered Logistic Regression model showed that the system marginal price is higher in the balancing market due to the merit order effect and increase in positive balance. Using the Generalized Additive model, Soini [6] approached the subject with a similar perspective by estimating the effect of wind surplus on the price of balancing power for Denmark. The study presented that balancing power prices are consistently higher during times of lower-than-expected wind power production even after controlling for other factors. Furthermore, Gebrekiros and Doorman [7] discussed the balancing energy market clearance from the perspective of the balancing service providers and transmission system operators. In their case study, an energy balancing market design and formulation were made where reserve capacity is procured by the transmission system operators. A decrease is observed in the balancing costs and the total net imbalances are obtained for the arrangement where transmission capacity is optimally allocated.

In the literature, there are also a number of studies that model and explain the fundamentals of energy imbalance considering liberalization and renewable energy technologies. Müsgens et al. [8] analyzed the economic fundamentals that govern market design and behavior in the German Balancing power market. In a similar study, Hirth and Ziegenhagen [9] reviewed three channels (generators, policies and market to be designed, imbalance price) through which renewable energy sources and balancing systems interact. Knaut et al. [10] focused on the German balancing market by exploring the impact of the tender frequency on the market concentration. Taking different scenarios into account, Ortner & Totschnig [11] focused on assessing the suitability of electricity balancing markets in Europe for 2030. A market model was set up to acquire a perspective about the market shares and profits of day-ahead, intra-day and balancing markets. The result showed that balancing volume will extend in the mid-term, notwithstanding, the financial size of the balancing market will fluctuate between a few percent of day-ahead market volumes. More recently, Schillinger [3] investigated the Swiss electricity balancing market and its adaptation to the energy transition.

Besides these fundamental studies, several machine learning and artificial intelligence techniques are applied in the studies that are related to the imbalance market. Kolmek and Navruz [12] forecasted the day-ahead price in the electricity balancing and settlement market for Turkey. They used ANN and ARIMA models to make a comparison according to MAPE results. In another study, Dinler [13] applied LSTM (Long Short Term Memory) method for the Turkish balancing market to test reducing the annual imbalance cost of a wind producer using the information extracted from the market data. This study revealed that the strategy performs reliably well and it may provide between a 6.3% and 11.2% decrease in the balancing cost for four tested wind power plants. In another price forecasting study, Lucas et al. [14] tried to understand

the dynamics and direction of the price by using three different machine learning algorithms (Random Forest (RF), Gradient Boosting (GB), Extreme Gradient Boosting (XGBoost)) According to the results of the comparison of the model, XGBoost presented better performance and it was selected for the implementation of the real-time forecast step. The model returns a 7.89 £/MWh MAE (Mean Absolute Error), an  $R^2$  score of 76.8% and a 124.74 MSE (Mean Squared Error).

Although there are some studies in the literature where Artificial Intelligence (AI) is used for energy imbalance, the number of these studies are quite inadequate. This study focuses on filling this gap by following the steps of Guven et al. [4]. The study aimed at predicting the sign trends in the power market by selecting the influencing factors. Genetic Algorithm (GA) with Akaike Information Criteria (AIC) was used to choose the factors with the highest impact which were then used as inputs of a Recursive Neural Network (RNN) model for forecasting the deviation model. The model was applied to perform a prediction for the day-ahead, ten hours, five hours ahead, two hours ahead and one hour ahead, and then the results were compared with other methods (Flipping coin, linear regression, GA and long term average). Although the day-ahead performance was not the best, the recommended model gave the best result among the other methods for the remaining hours.

### 3 The Turkish Power Market

The Turkish power market has undergone crucial changes over the last two decades. The size of the energy market has increased significantly with the changing energy resources with renewable energy technologies, increasing competition with liberalization, and the participation of numerous producers, wholesalers, retailers and regulatory entities. The value chain of the Turkish electricity market consists of [15];

- Generation
- Transmission
- Wholesale
- Distribution
- Retail
- Import Export

Private and state-owned companies are responsible for wholesale activities. Electricity is traded by the system participants in the wholesale market. The wholesale market structure is shown in Figure 1. Electricity is traded physically and non-physically. Physical electricity trading is done through bi-literal agreements in the derivative market, as spot day-ahead and intraday electricity market and in real-time balancing and ancillary service markets. Day-ahead is an electric market where electricity is traded for the next day. In this market, the Market Clearing Price (MCP) is defined by Merit Order. In intraday, electricity transactions are organized until the market closes during the day. This market provides additional trade opportunities, liquidity, elimination imbalance etc.

In the Balancing Power Market, electricity as a requisite commodity is traded based on the market rules with spot and derivative as seen below. For the sake of the electricity grid, it is crucial to set a balance between generation and consumption.

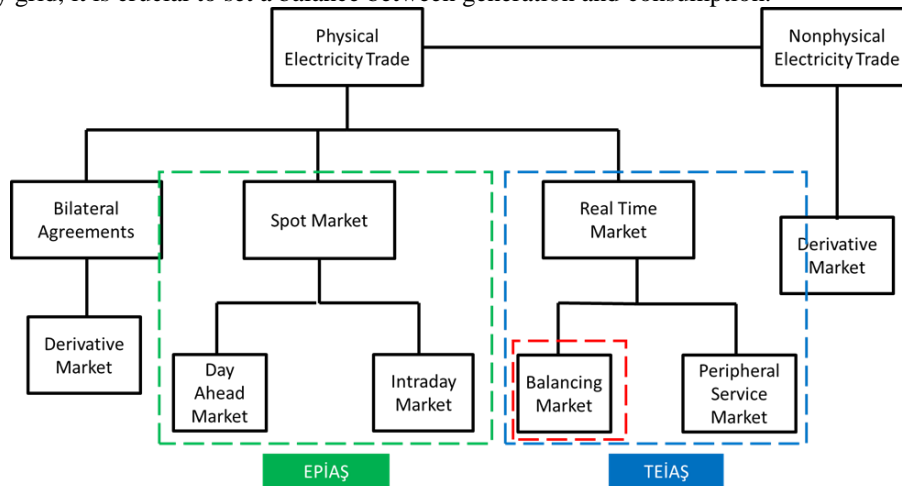

**Fig. 1.** Wholesale market structure

Setting a perfect balance between generation and consumption is not easy because of the consumption forecast errors, deviations of renewable power plants and power plants failures. The balancing power market is operated by the Turkish Electricity Transmission Company (TETC, TEİAŞ). Although National Load Dispatch Centre presents balanced production and consumption with the day-ahead market, deviations may occur in real-time [4]. The results of these deviations either cause an unexpectedly insufficient supply, which makes the frequency drop below 50 Hz, or an oversupply of electricity, which makes frequency rise above 50 Hz. In the case of insufficient supply, positive balancing power is required. This can be provided by the supply side in the form of an extra amount of generated electricity or by the demand side in the form of reduced consumption. In the case of oversupply of electricity, negative balancing power has to be provided [8].

Balancing power could be provided either as a decentralized system by the responsible balancing group operators or as a centralized system service by the system operators. This is usually done for several reasons;

- In the short run, the price elasticity of both demand and supply on electricity markets is close to zero.
- The difference between the current generation and current consumption causes the frequency to deviate from the target value of 50 Hz. In the case of a decentralized balancing power system, the costs of reliability of supply would be individualized. However, the costs of an insufficient balancing power provision caused by frequency fluctuations and blackouts would be borne by all grid users.

- In the case of a centralized balancing mechanism, compensations between different balancing groups can be utilized.

## 4 Methodology

This study combines two methods. The first one is the Particle Swarm Optimization algorithm. It is applied to raw data to select the most effective features. The selected features are used as inputs for the deep learning algorithm.

PSO is an optimization technique inspired by the social behavior of birds or schools of fish. PSO is a population-based stochastic method and very similar to evolutionary computation techniques, such as Genetic Algorithm (GA). However, unlike GA, PSO has no evolution operator [16]. PSO has some advantages compared with other methods;

- PSO can have better results in a faster, cheaper way,
- PSO does not require the problem to be differentiable,
- PSO has very few hyperparameters,
- PSO will work on a very wide variety of tasks, which makes it a very powerful and flexible algorithm.

In PSO algorithm there are some important features, these are; particle, velocity, swarm and optimization;

*Particle.* Particles are potential solutions and they all scatter around in the search space by randomized function. In the search space, there is only one global optimum. Particles try to achieve that solution by fitness value that is evaluated by the fitness function.

$$P_i^t = [X_{0,i}^t, X_{1,i}^t, X_{2,i}^t, X_{3,i}^t, \dots, X_{n,i}^t] \quad (1)$$

Randomly defined particles are illustrated in a basic sphere function in Figure 2.



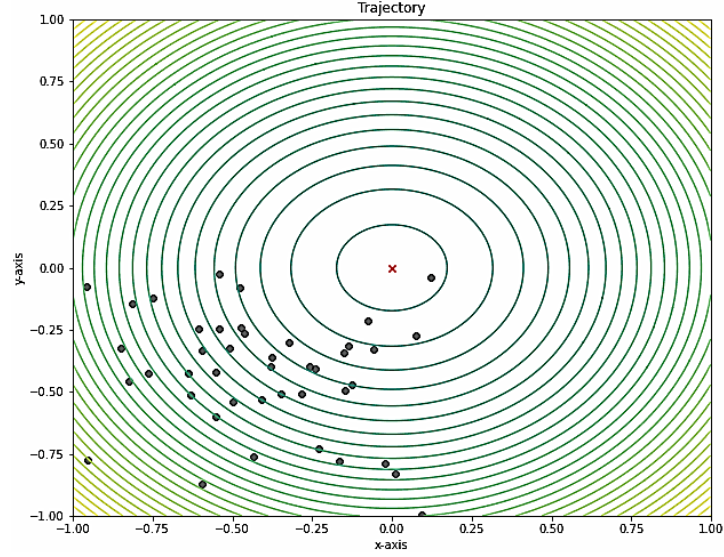

**Fig. 2.** An example of randomly defined particles

A fitness function is a particular type of “objective function”, it specifies how close is a given design solution for achieving the set aims. ( $\alpha = 0.99, \beta = 1 - \alpha$ )

$$Fitness = \alpha \times (1 - kNN_{acc}) + \beta * \left( \frac{num\ of\ feats}{max\ features} \right) \quad (2)$$

*Velocity.* In the search space, these particles are in the movement with a velocity allowing them to update their position over the iterations to find the global optimum. The velocity vectors are also randomized by a random function.

$$V_i^t = [v_{0,i}^t, v_{1,i}^t, v_{2,i}^t, v_{3,i}^t, \dots, v_{n,i}^t] \quad (3)$$

New positions of randomly defined particles, which are changed by velocity vector, are illustrated in Figure 3.

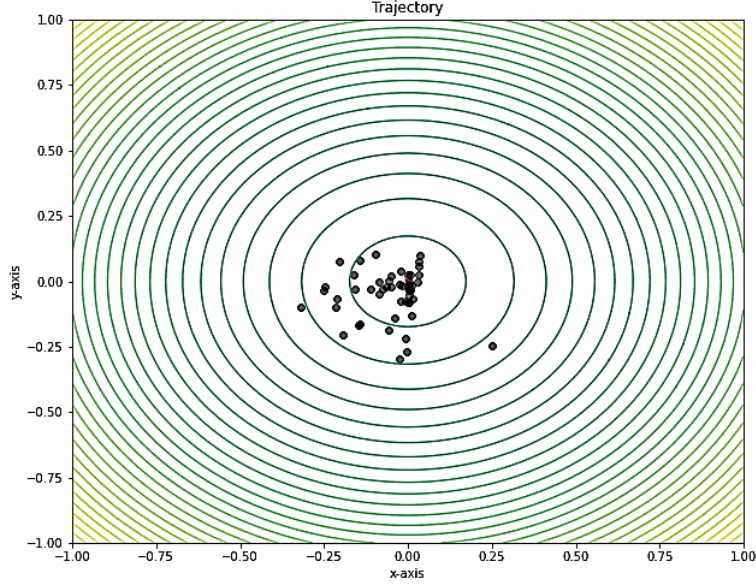

**Fig. 3.** New position of randomly defined particles.

*Swarm.* Over the iterations in the search space, the current position is changed with the velocity. Each particle is stochastically accelerated towards its best position. This new position is called personal best and it is constantly upgraded over the iterations. These particles also accelerate towards the best solution of the swarm and are called the global best. The velocity is subject to inertia and is governed by the two best values found so far.

$$P_i^{t+1} = P_i^t + V_i^{t+1} \quad (4)$$

$$V_i^{t+1} = w \cdot v_i^t + c_1 \cdot r_1 \cdot (P_{best, personal, i}^t) + c_2 \cdot r_2 \cdot (P_{best, global, i}^t) \quad (5)$$

The first value is the best personal solution that is found by each particle. The second one is the best global solution that the swarm of particles are found so far. Thus, each particle has the best personal solution and the best global solution in their memory.

*Optimization.* Personal acceleration and social acceleration are stochastically adjusted by the weights  $r_1$  and  $r_2$ . These two weights  $r_1$  and  $r_2$  are unique for each particle and each iteration. Hyperparameter  $w$  allows defining the ability of the swarm to change its direction. The particles have inertia proportional to this coefficient  $w$ . The inertia weight  $w$  makes a balance between the exploration and the exploitation of the best solutions found so far. Exploitation is the ability of particles to target the best solutions found. Exploration is the ability of particles to evaluate the entire research space.

$$w \in R^+; \quad \text{Inertia} \quad (6)$$

$$\begin{aligned} r_1 \in [0,2] \quad & \text{cognitive (personal)} \\ c_1 \in R^+ \end{aligned} \quad (7)$$

$$\begin{aligned} r_2 \in [0,2] \\ c_2 \in R^+ \end{aligned} \quad (8)$$

The PSO can be used for feature selection. The algorithm tries to find a subset of features that optimize a certain fitness function. The feature columns in the dataset are considered as dimensions from which the PSO algorithm will select the optimal subset of dimensions through iterations. The algorithm of PSO Feature selection is given below;

*Initialize Population*

*While (number of generation or stopping the stopping criterion is not met)*

*for p =1 to number of particles*

*if the fitness of  $X_p$  is greater than the fitness of  $p_{best}$*

*then update  $p_{best} = X_p$*

*for  $k \in$  Neighbourhood of  $X_p$*

*if the fitness of  $X_k$  greater than the fitness of  $g_{best}$*

*then update  $g_{best} = X_k$*

*Next k*

*For each dimension d*

$$V_i^{t+1} = w \cdot v_i^t + c_1 \cdot r_1 \cdot (P_{best, personal, i}^t) + c_2 \cdot r_2 \cdot (P_{best, global, i}^t)$$

*if  $V_i^{t+1}$  is not in  $(V_{min}, V_{max})$  then*

$$V_i^{t+1} = \max(\min(V_{max}, V_i^{t+1}), V_{min})$$

$$X_{pd} = X_{pd} + V_{pd}$$

*Next d*

*Next p*

*Train Neural Network with the Selected Features;*

In the fitness function, firstly, we need to find the error function. For this process, k-nearest neighbors (k-NN) and multi-linear regression (MLR) methods are tested. Although both methods perform very similar, k-NN is selected to find the error value of the fitness function due to the shorter working time.

After the feature selection process is completed, the new dataset obtained with the selected feature is used as an input for a neural network. Recurrent Neural Networks is chosen because it has a memory state that processes a variable-length sequence of inputs, a quicker convergence, and more accurate mapping capability [17]. In this study, Long Short Term Memory (LSTM) as RNN variants has been chosen. LSTM has a unique feedback connection, which makes it different from the traditional RNNs. This property enables to process the entire sequence of data without treating each data point as independent. LSTM consists of cells with a gate system instead of nodes. In Figure 4, an LSTM cell has been illustrated.

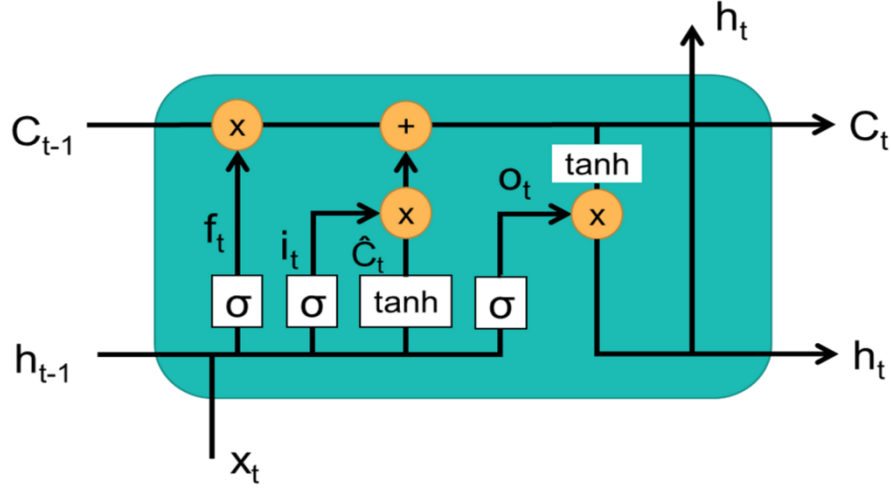

Fig. 4. LSTM cell

$i_t$ : input gate of the cell,  
 $f_t$ : forget gate of the cell,  
 $o_t$ : output gate of the cell,  
 $\hat{C}_t$ : candidate hidden state for the cell at timestamp ( $t$ )  
 $C_t$ : cell state (internal memory) at timestamp ( $t$ )  
 $h_t$ : predicted output from the current block.  
 $W$ : the recurrent connection between the previous and current hidden layers.  
 $U$ : the weight matrix that connects the inputs to the hidden layer.

The output of LSTM depends on three things;

- Cell State: The current long-term memory of the network
- Hidden State: The output of the previous point in time
- The input data at the current time step

The gate mechanism of LSTM controls the information in a sequence of the data that comes, stored and leaves the network.

*Forget Gate.* In this gate, previous hidden state data and the new input data are fed into the network. This network generates a vector which is an element in the interval  $[0,1]$  by the sigmoid function. Data points that are close to 0 can be forgotten because of the less influence on the following step and the data points that are close to 1 are relevant. These outputs are then sent to pointwise multiplication.

$$f_t = \sigma(x_t U_f + h_{t-1} W_f) \quad (9)$$

*Input Gate.* In this gate, the goal is to determine what new information should be added to the network long term memory. The memory network has a  $\tanh$  activation

step because derivative of  $\tanh$  does not reach 0 immediately; the network can learn how to combine the pre-hidden state and the new memory update vector. The input gate is a sigmoid activated network as well. In this gate sigmoid function act as a filter. The output of the input gate is again pointwise multiplied then added to the cell state.

$$i_t = \sigma(x_t U_i + h_{t-1} W_i) \quad (10)$$

$$\hat{C}_t = \tanh(x_t U_g + h_{t-1} W_g) \quad (11)$$

*Output Gate.* The main objective of output gate is deciding the new hidden state. The output gate works like forget gate. In the first stage, the  $\tanh$  function is applied to the current cell state pointwise to obtain the squished cell state. This is followed by passing the previous hidden state and current input data through the sigmoid activated neural network to obtain the filter vector. Finally, one must apply this filter vector to the squished cell state by point wise multiplication. To convert the hidden state to the output, a linear layer needs to be applied in the very last step of the LSTM process.

$$o_t = \sigma(x_t U_o + h_{t-1} W_o) \quad (12)$$

$$C_t = \sigma(ft * C_{t-1} + i_t * \hat{C}_t) \quad (13)$$

$$h_t = \tanh(C_t) * o_t \quad (14)$$

The methodology of this study is illustrated in Figure 5.

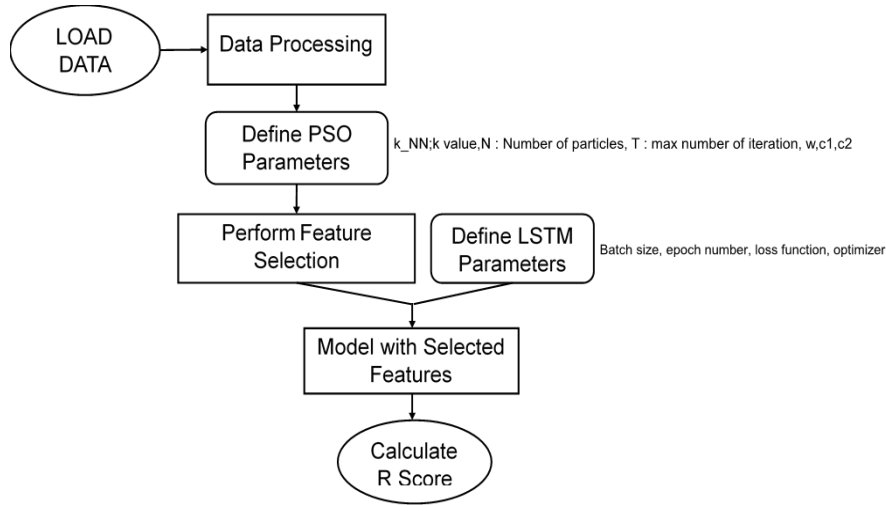

**Fig. 5.** Flowchart model.

**Data.** Market energy data from the Transparency Platform and TETC, historic data and the system direction as a target are chosen for the input for the PSO algorithm to find the best features. For market data, system marginal price (SMP) and market clearing price (MCP) for both lagged day and latest hour, frequency capacity price, petroleum pipeline company (BOTAS) price and net loading output data are considered. In

addition, CCGT coal, renewable energy, demand forecast, and demand forecast error are used as inputs. Year, day of the year, month, day of the month, weekday and hour are the historic features of the raw data input. The hourly values of the last two years are selected for the data. The correlation matrix of the data is illustrated in Figure 6.

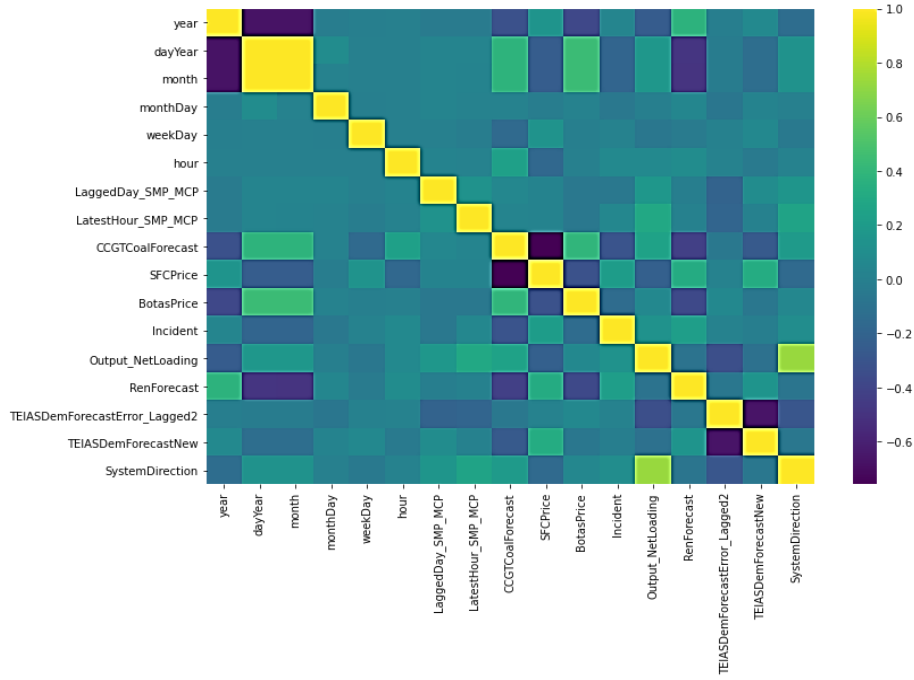

**Fig. 6.** Correlation matrix of the data

A total of 17 features are used as inputs for the PSO model. Best features are obtained from the model. These features are used as new parameters for the imbalance volume prediction data that will be used to find the results with the LSTM model.

## 5 Results and Discussion

In the first step, for the fitness function of the PSO algorithm, we need to find the error function. For this process, k-NN and the MLR are tested. k-NN provided the feature selection results quicker than the MLR (12 min vs. 17 min). k-NN is chosen for the error function (1- accuracy). For the k value, asset of 3 to 9 are tested and the best value 5 is taken for consideration. The hyperparameters are chosen from the literature; the inertia ( $w$ ) is 0.9, the acceleration coefficient for personal best is 2, and the acceleration coefficient for global best is 2. System upper and lower bounds are defined as 1 and 0. As a result of the PSO algorithm with the selected features, a total of 3 features are

selected out of 17. These are latest hour SMP and MCP, BOTAS price and net loading output. The feature selection process is illustrated in Figure 7.

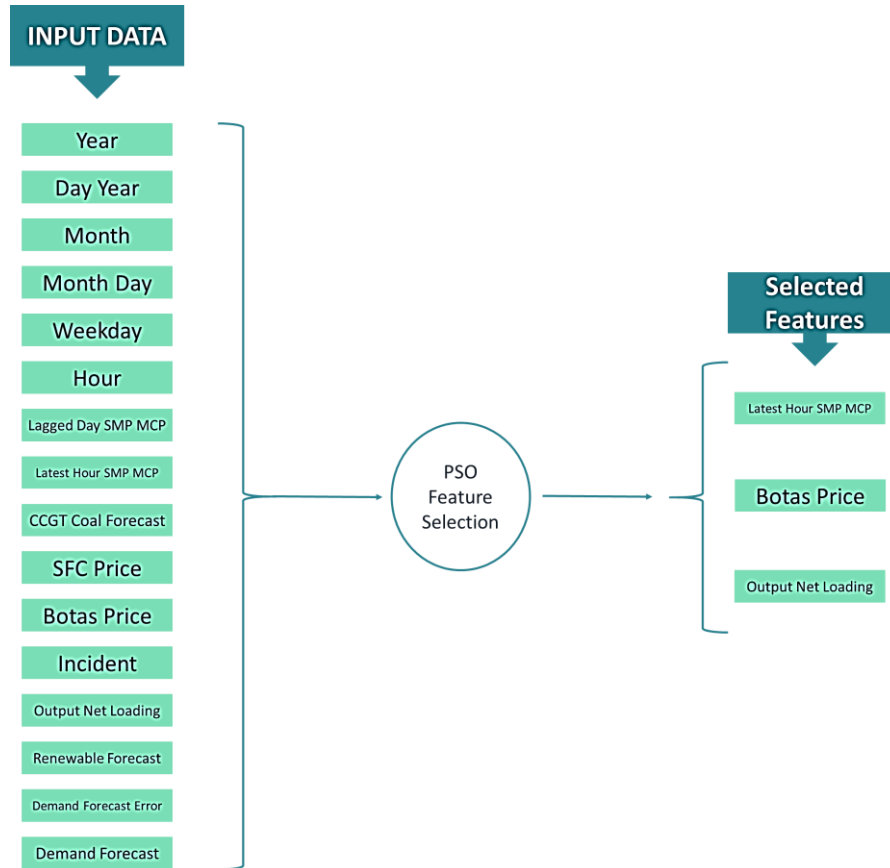

**Fig. 7.** Feature selection process

The change in fitness function error over iterations is given in Figure 8. Before starting the PSO modeling, the data were normalized. While the error values were 0.094 in the first iteration, they decreased to 0.04 levels as the particles approached the global optimum at the end of each iteration and continued at a constant value after a certain point. With the features we obtained as a result of the PSO algorithm, we can make predictions with cleaner perspective.

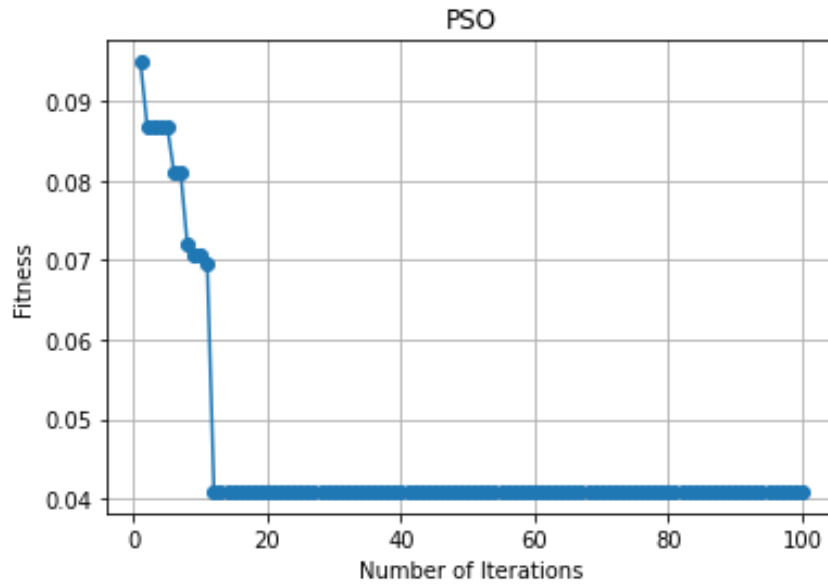

**Fig. 8.** Feature selection process of PSO

Selected features created a new data set with a new target which is imbalancing volume. Since we used classification methods to find fitness function error, we cannot use the imbalance volume at the feature selection process. This data set is used as input for LSTM. In the LSTM, 50-150 and 250 units are tested, but there is no significant change in the results. Eventually, 50 units are selected because of the faster performance. After a certain point, the error of the validation and training data remained stable. Hence, for the fastest performance, data are trained for 32 times. Optimizer is selected as *adam*. 32 training examples are utilized in one iteration. Error is calculated using Mean Absolute Error and a decline is observed in each train as illustrated for 1 hour ahead prediction in Figure 9.



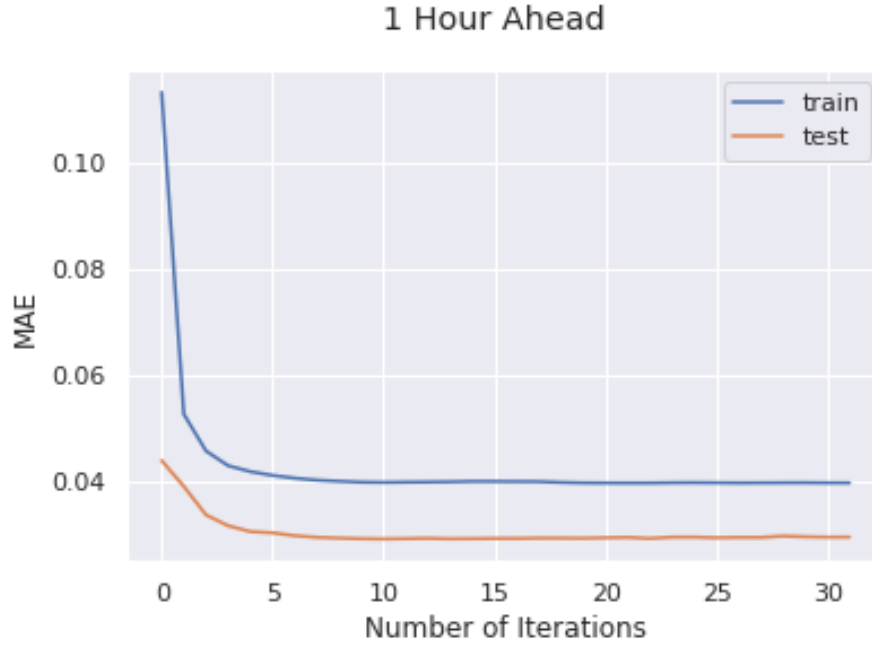

**Fig. 9.** Mean Absolute Error for 1 hour ahead model performance

This model is applied for 1 hour, 4-hours, 8-hours, 12-hours and 24-hours ahead and Mean Absolute Percentage Error (MAPE) is calculated. MAPE is the most common measure used to forecast error, and it works best if there are no extremes and no zeros in the data. While the proposed model produces much better result for 1 hour ahead, it may not be sufficient for 4 hours and earlier predictions. However, this model is likely to give better results than many models in the literature when the 1-hour-ahead predictions are compared (data usage can make differences). In Figure 10, the change of MAPE values according to time is shown. Although the MAPE values are higher in the previous estimates, it can be said that the system user will reduce the risks in taking an early position according to the model results. The MAPE levels are found to be 27.41 for 24 hours, 25.66 for 12 hours, 26.77 for 8 hours, 25.39 for 4 hours, 9.25 for 1 hour. Despite the low error rate of this model, the dataset should be reviewed carefully. The biggest problem of the data set is detected as the lack of hourly weather data which may affect the model significantly.

$$MAPE = \frac{1}{n} \sum_{t=1}^n \left| \frac{A_t - F_t}{A_t} \right| \quad (15)$$

n: number of fitted points

$A_t$ : actual value

$F_t$ : forecast value

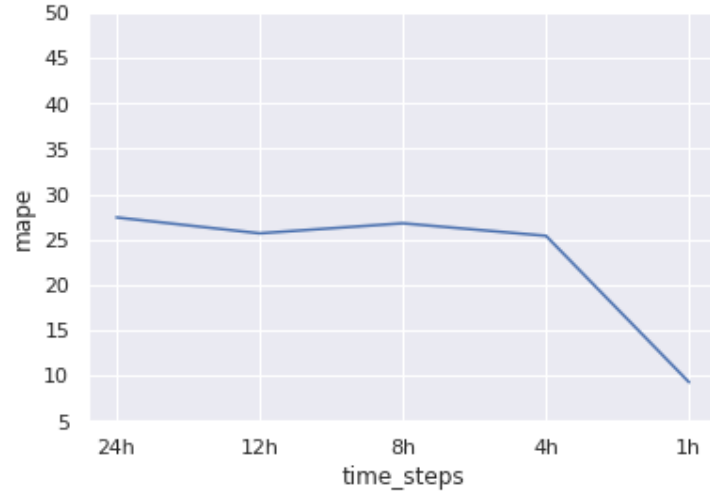

**Fig. 10.** MAPE levels for different time horizons

## 6 Conclusion

To know the system direction is very essential for the system participants since any imbalance costs is reflected to the utility companies. For this reason, participants should define their positions by using artificial intelligence or other prediction methods. This study is focused on predicting the imbalance direction using LSTM by selecting the best features by the PSO algorithm. In this study, a hybrid model is constituted to predict day-ahead and some time periods before the targeted hour. Therefore, in the next step, the LSTM structure has to be improved to make a classification in several time periods. The established model is applied for 1 hour, 4-hours, 8-hours 12-hours and 24-hours ahead. Also, Mean Absolute Percentage Error (MAPE) is calculated. The MAPE levels are found to be 27.4 for 24 hours, 25.7 for 12 hours, 26.8 for 8 hours, 25.4 for 4 hours, 9.3 for 1 hour. While the proposed model produces a much better result for 1 hour ahead, it may not be sufficient for 4 hours and earlier predictions. However, it can be said that with the increasing number of artificial intelligence applications in the energy field, the imbalance prediction will get closer to real-time and the benefits of system participants will increase. Moreover, acquisitions of the established model will assist all stakeholders and key market players in countries which has partly liberated power markets.

## References

1. Hache E, Palle A (2019) Renewable energy source integration into power networks, research trends and policy implications: A bibliometric and research actors survey analysis. *Energy Policy* 124:23-35.
2. Lago J, Poplavskaya K, Suryanarayana G, De Schutter B (2021) A market framework for grid balancing support through imbalances trading. *Renewable and Sustainable Energy Reviews* 137:110467.
3. Schillinger, M. (2020) Balancing-market design and opportunity cost: The Swiss case. *Utilities Policy* 64:101045.
4. Guven D, Ozozen A, Kayakutlu G, Kayalica MO (2021) Predicting Power Deviation in the Turkish Power Market based on Adaptive Factor Impacts. In: IFIP International Workshop on Artificial Intelligence for Knowledge Management. Springer Cham., pp 213-234.
5. Sirin SM, Yilmaz BN (2021) The impact of variable renewable energy technologies on electricity markets: An analysis of the Turkish balancing market. *Energy Policy* 151:112093.
6. Soini V (2021) Wind power intermittency and the balancing power market: Evidence from Denmark. *Energy economics* 100:105381.
7. Gebrekiros Y, Doorman G (2014) Balancing energy market integration in Northern Europe-Modeling and case study. In: 2014 IEEE PES General Meeting Conference & Exposition. IEEE, pp 1-5.
8. Müsgens F, Ockenfels A, Peek M (2014) Economics and design of balancing power markets in Germany. *International Journal of Electrical Power & Energy Systems* 55:392–401.
9. Hirth L, Ziegenhagen I (2015) Balancing power and variable renewables: Three links. *Renewable and Sustainable Energy Reviews* 50:1035–1051.
10. Knaut A, Obermüller F, Weiser F (2017) Tender Frequency and Market Concentration in Balancing Power Markets. Unpublished.
11. Ortner A, Totschnig G (2019) The future relevance of electricity balancing markets in Europe-a 2030 case study. *Energ. Strat. Rev.* 24: 111–120.
12. Kölmek MA, Navruz I (2015) Forecasting the day-ahead price in electricity balancing and settlement market of Turkey by using artificial neural networks. *Turkish Journal of Electrical Engineering & Computer Sciences* 23:841-852.
13. Dinler A (2021) Reducing balancing cost of a wind power plant by deep learning in market data: A case study for Turkey. *Applied Energy* 289:116728.
14. Lucas A, Pegios K, Kotsakis E, Clarke D (2020) Price Forecasting for the Balancing Energy Market Using Machine-Learning Regression. *Energies* 13:5420.
15. Overview of the Turkish Electricity Market August 2020. [pwc.com.tr](http://pwc.com.tr) & Aplus Enerji
16. Eberhart RC, Shi Y (1998) Comparison between genetic algorithms and particle swarm optimization. In: *Lecture Notes in Computer Science*. Springer Berlin Heidelberg, pp 611–616.
17. Brito R, Fong S, Zhuang Y, Wu Y (2017) Generating Neural Networks with Optimal Features through Particle Swarm Optimization. In: *Proceedings of the International Conference on Big Data and Internet of Thing - BDIOT2017*. ACM Press, pp 96-101.