



HAL
open science

Investigating Long-Term Context of Language Models on Brain Activity during Narrative Listening in fMRI

Subba Reddy Oota, Frédéric Alexandre, Xavier Hinaut

► **To cite this version:**

Subba Reddy Oota, Frédéric Alexandre, Xavier Hinaut. Investigating Long-Term Context of Language Models on Brain Activity during Narrative Listening in fMRI. FENS Forum 2022, Jul 2022, Paris, France. hal-03699886

HAL Id: hal-03699886

<https://inria.hal.science/hal-03699886>

Submitted on 20 Jun 2022

HAL is a multi-disciplinary open access archive for the deposit and dissemination of scientific research documents, whether they are published or not. The documents may come from teaching and research institutions in France or abroad, or from public or private research centers.

L'archive ouverte pluridisciplinaire **HAL**, est destinée au dépôt et à la diffusion de documents scientifiques de niveau recherche, publiés ou non, émanant des établissements d'enseignement et de recherche français ou étrangers, des laboratoires publics ou privés.

Introduction

- 1 Sequence-based and pretrained language models have been found to be successful for text-driven prediction of brain activations.
- 2 However, these models still lack long-term memory plausibility (i.e. how they deal with long-term dependencies and contextual information)

Can current language models deal with long-term dependencies?

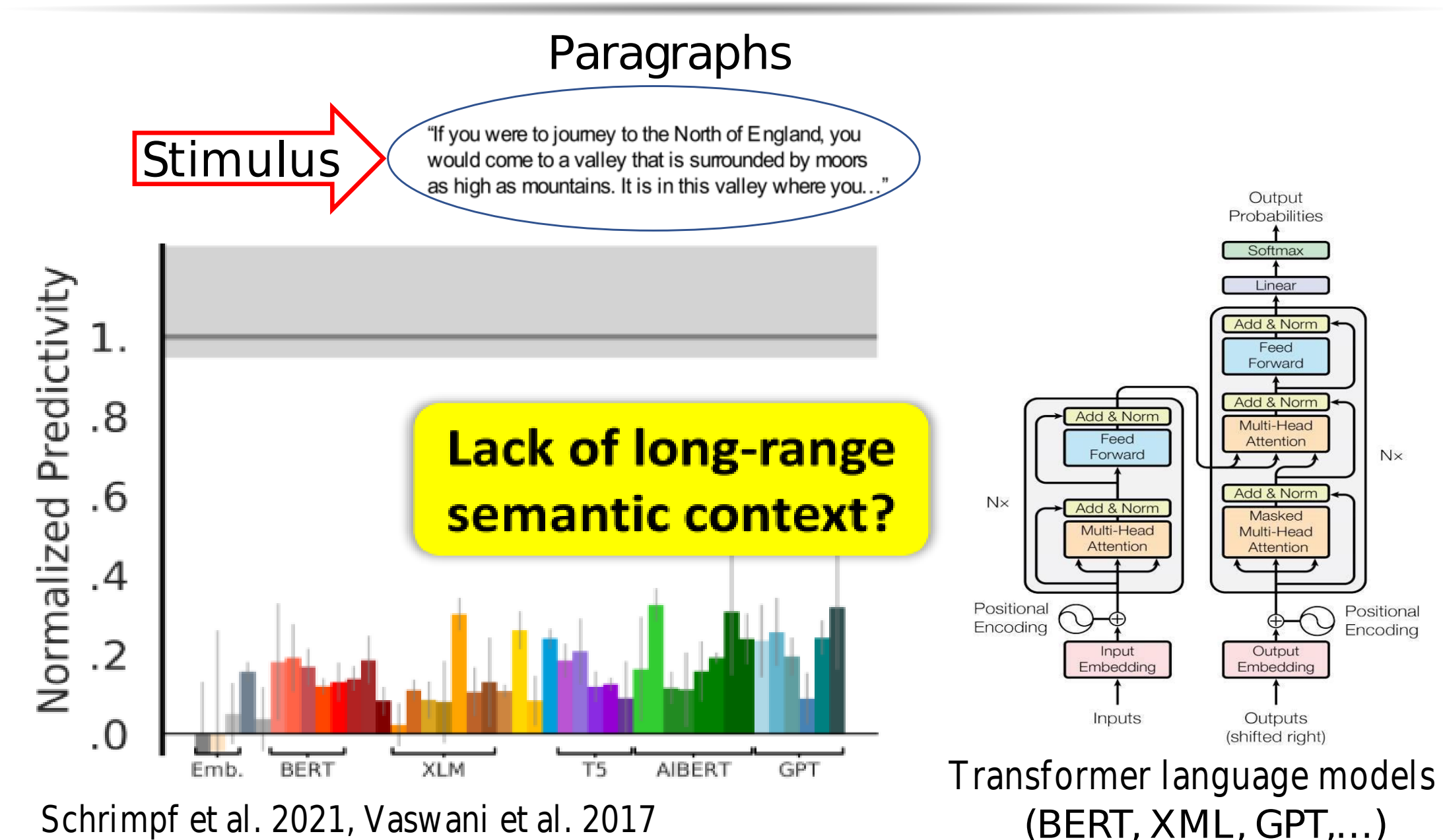

Figure 1: Sequence length is fixed to 512 words in Transformers.

Questions

- 1 What kind of language models can represent long-term dependencies?
- 2 Could these language models also predict better brain activity while subjects are engaged in longer stories?

Main Contributions

- 1 We propose the problem of finding which type of language models are the most predictive of fMRI brain activity for listening tasks.

Models Considered

- 1 GloVe, Long Short-Term Memory Networks (LSTM)
- 2 ELMo, Longformer

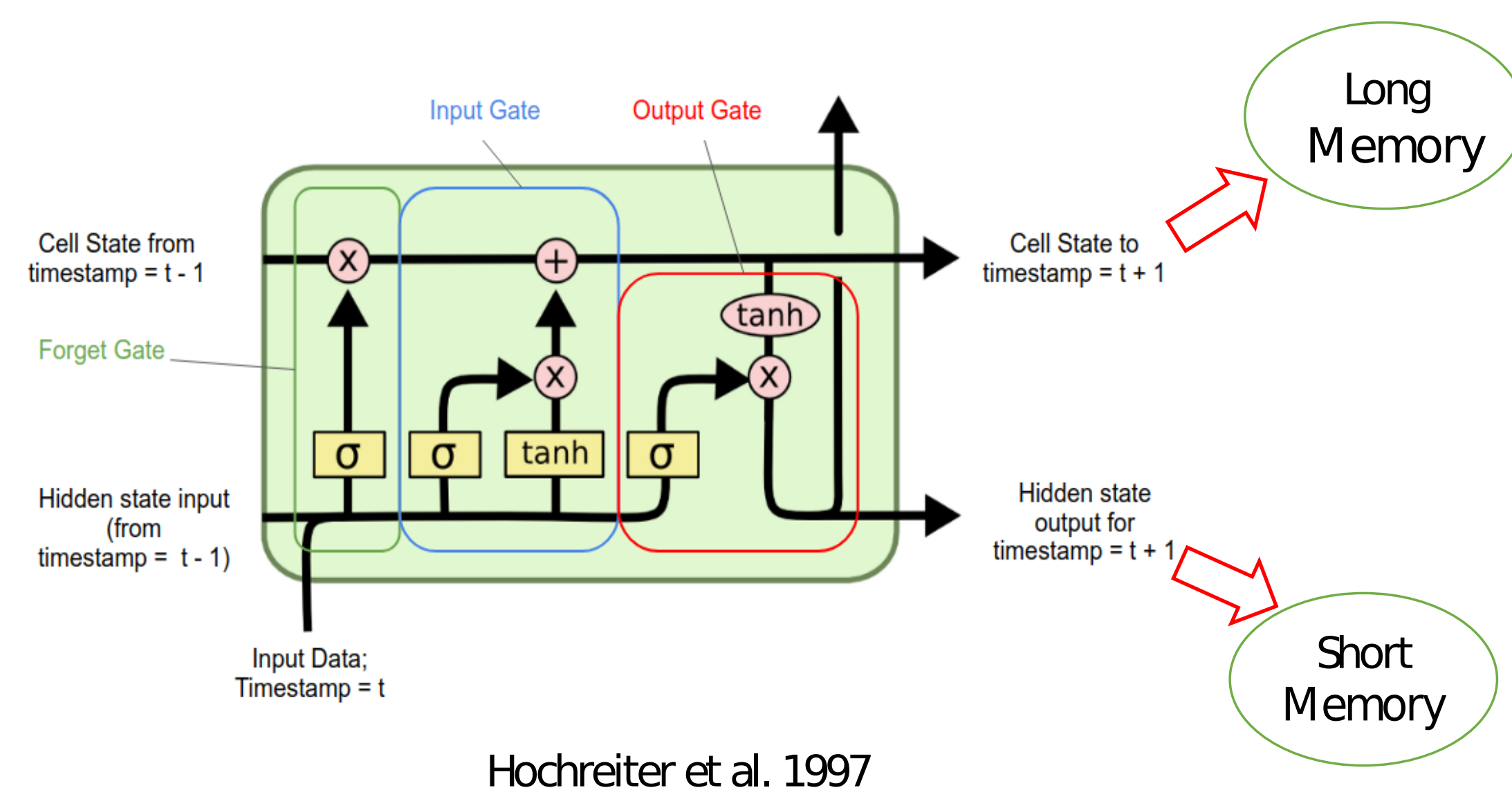

Evaluation Metrics

- 1 2V2 Accuracy
- 2 Pearson Correlation (R)

Brain Encoding

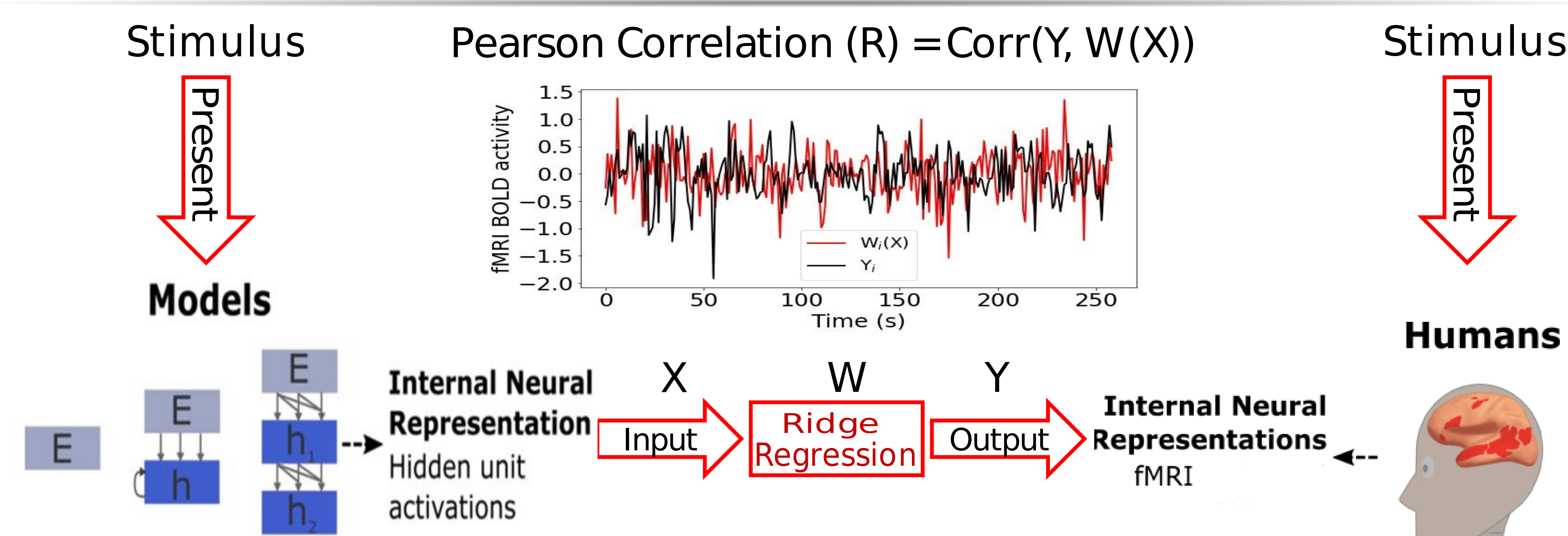

Narrative Listening (Pieman dataset from Nastase et al. 2021)

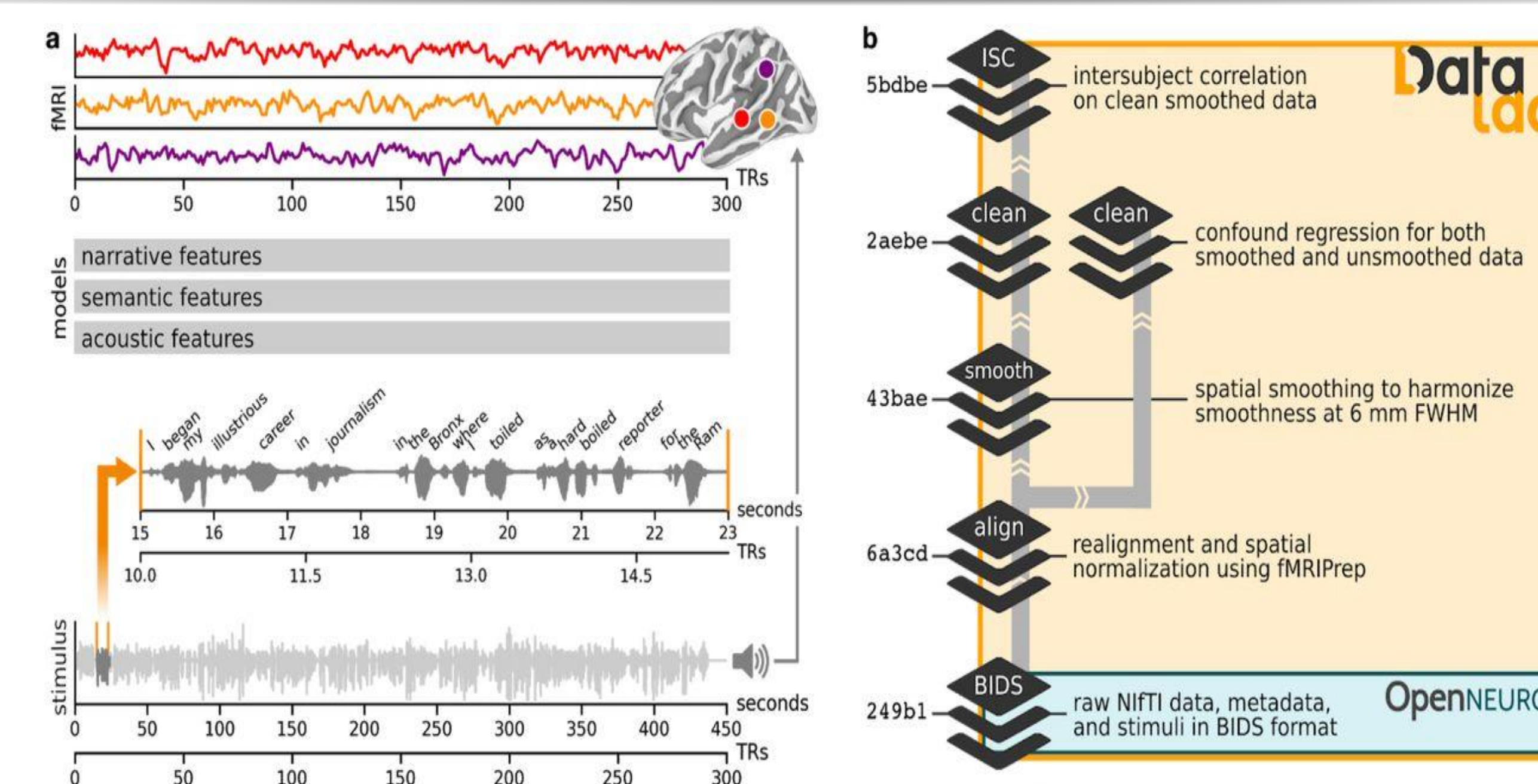

Figure 2: Whole Brain

Cognitive Insights

- 1 In LSTM, the cell state representations (long term memory vector) yield better encoding performance than hidden state representations.
- 2 We used different layers of ELMo and Longformer, where higher layers display better correlation for ELMo while intermediate layers show superior performance for Longformer.

Conclusion

- Language models with longer context (e.g. Longformer) better predict brain activity while subjects listening to stories.
- Future Directions: (i) Use more plausible language models than Transformers. (ii) Make hierarchical language models.

References

- [1] Martin Schrimpf et al. 2021. The neural architecture of language: Integrative modeling converges on predictive processing.
- [2] Ashish Vaswani et al. 2017. Attention is all you need.
- [3] Samuel A Nastase et al. 2021. The “narratives” fMRI dataset for evaluating models of naturalistic language comprehension.

Acknowledgements

- We thank Gaël Jobard and Clara Moreau for their very helpful comments on the poster.

Encoding Performance of Language Models

