



HAL
open science

Adaptive motion control of robot manipulators: A unified approach based on passivity

Bernard Brogliato, Ioan Doré Landau, Rogelio Lozano-Leal

► To cite this version:

Bernard Brogliato, Ioan Doré Landau, Rogelio Lozano-Leal. Adaptive motion control of robot manipulators: A unified approach based on passivity. *International Journal of Robust and Nonlinear Control*, 1991, 1 (3), pp.187-202. 10.1002/rnc.4590010305 . hal-03611279

HAL Id: hal-03611279

<https://inria.hal.science/hal-03611279v1>

Submitted on 17 Mar 2022

HAL is a multi-disciplinary open access archive for the deposit and dissemination of scientific research documents, whether they are published or not. The documents may come from teaching and research institutions in France or abroad, or from public or private research centers.

L'archive ouverte pluridisciplinaire **HAL**, est destinée au dépôt et à la diffusion de documents scientifiques de niveau recherche, publiés ou non, émanant des établissements d'enseignement et de recherche français ou étrangers, des laboratoires publics ou privés.

ADAPTIVE MOTION CONTROL OF ROBOT MANIPULATORS: A UNIFIED APPROACH BASED ON PASSIVITY

BERNARD BROGLIATO AND IOAN-DORÉ LANDAU

*Laboratoire d'Automatique de Grenoble, ENSIEG-INPG, URA CNRS 228, BP 46, 38402 Saint-Martin d'heres,
France*

AND

ROGELIO LOZANO-LEAL

*Université de Technologie de Compiègne, Heudiasyc, URA CNRS 817, Centre de Recherches de Royalieu,
BP 233, 60206 Compiègne Cedex, France*

SUMMARY

This paper presents a unified approach to direct adaptive motion control laws for robot manipulators that have been studied during the last few years by several authors. It provides a general approach based on passivity to demonstrate the global asymptotic stability of adaptive schemes applied to rigid multilinked manipulators. It is shown that most of the schemes fit within this framework, which presents the advantage of being more systematic than other techniques and therefore will enable a unified presentation of the several schemes proposed to date and will increase our understanding of adaptive control of robot manipulators.

1. INTRODUCTION

The last few years have witnessed an increasing interest in adaptive control of robot manipulators and several different schemes have been proposed. The first robot adaptive control algorithms were based on local linearization techniques.¹ The main drawback of this approach is the lack of global stability. More recently adaptive schemes based on linear parametrization of the robot dynamics have emerged.²⁻¹⁴ We will focus our attention on these latter, which can in turn be separated into two classes: (i) inverse dynamics based control schemes assuming joints acceleration measurements or inversion of the estimated inertia matrix,²⁻⁵ and (ii) schemes which use only joint velocity and position measurements and which do not require any inversion of the estimated inertia matrix.⁶⁻¹⁴ In view of the practical limitations of the earlier ones, we will consider here just those schemes using only joint position and velocity measurements. Passivity will be used as an analysis tool as advocated in Reference 15, where the authors considered the analysis of References 6 and 7 from the hyperstability point of view.

This paper exploits the passivity properties of mechanical manipulators to present an adaptive control scheme based on passivity. It provides a general framework that most of the

schemes proposed to date can be turned into. The simplicity of the approach will increase our understanding of direct adaptive control of robot manipulators.

The paper is organized as follows. Section 2 presents the notation and robots dynamics. A unified equivalent scheme of robot adaptive control is presented in Section 3. Section 4 is devoted to showing that almost all direct adaptive laws can be turned into that scheme. In order to complete the proof of stability, we show in section 5 that all the signals within the system remain bounded, utilizing passivity results previously stated. Conclusions are given in Section 6 and most of the proofs are given in the Appendices A–D.

2. DYNAMIC MODEL OF ROBOT MANIPULATORS

Consider a rigid, n -degree-of-freedom manipulator. Using the Lagrangian formulation, one can show that the dynamic model of such a mechanical system can be written as follows:

$$M(q)\ddot{q} + C(q, \dot{q})\dot{q} + g(q) = \tau \quad (1)$$

Where: q, \dot{q}, \ddot{q} represent the joint position, velocity and acceleration $n \times 1$ vectors, $M(q)$ is the $n \times n$ inertia matrix, $C(q, \dot{q})$ is a $n \times n$ matrix which represents centripets and Coriolis inertial terms, $g(q)$ represents the gravity torque $n \times 1$ vector and τ is the $n \times 1$ torque vector supplied by the joint actuators.

Though it is obvious that robot manipulators are complex nonlinear systems, the following properties make them appear as a particular class of these systems, and facilitate their study and design (see References 17 and 18 for details):

- (1) $M(q)$ is a symmetric positive-definite matrix, lower-bounded for $q \in R^n$.
- (2) Consider all the parameters of interest in adaptive control such as link masses, moments of inertia etc., represented by an $n \times r$ vector θ . Then the robot dynamic equations can be expressed as a linear relationship between these unknown parameters and torque τ :

$$\tau = Y(q, \dot{q}, \ddot{q})\theta$$

where $Y(q, \dot{q}, \ddot{q})$ is a $n \times r$ matrix of known functions, known as the regressor.

- (3) There exists a particular definition of $C(q, \dot{q})$ such that the matrix

$$N(q, \dot{q}) = C(q, \dot{q}) - \frac{1}{2} \dot{M}(q)$$

is skew-symmetric.

3. PASSIVITY RESULT

As will be shown in the next section, it is always possible (at least for the class of control laws considered here) to interpret the closed-loop error equation obtained by replacing the control law into the manipulator dynamics as a feedback system composed of three main blocks (Figure 1) where:

- (1) B1 contains signals resulting from the closed-loop equation and is always strictly passive.
- (2) B2 contains the robot-dynamics (with $g(q) = 0$), i.e.

$$\bar{\tau} = - [M(q)\dot{v} + C(q, \dot{q})v] \quad (2)$$

- (3) B3 contains the parameter adaptation algorithm.

(4) In order to avoid acceleration measurement, v is obtained by filtering the tracking error

$$v = H(s)^{-1}\tilde{q} \quad (3)$$

where the transfer function $H(s)$ will be specified later and the tracking error is given by

$$\tilde{q}(t) = q(t) - q_d(t) \quad (4)$$

q_d denoting the twice differentiable bounded desired trajectory.

We are now able to apply the following theorem (Reference 16, p. 181).

Theorem

Consider the scheme in Figure 1. Assume B1 is a strictly passive system. If B2 and B3 are passive blocks, then

$$v(t) \in L_2^2$$

Proof. The proof follows from standard passivity arguments (see References 15 and 16). In order to prove that the tracking error signal converges to zero, we now invoke the following lemma (Reference 16, p. 59).

Lemma

Let

$$\tilde{q} = H(s)v \quad (5)$$

where $H(s)$ is an $n \times m$ strictly proper, exponentially stable transfer function.

Then $v \in L_2^m$ implies that $\tilde{q} \in L_2^n \cap L_\infty^n$, $\dot{\tilde{q}} \in L_2^n$, \tilde{q} is continuous and $\tilde{q} \rightarrow 0$ as $t \rightarrow \infty$.

4. SYSTEM EQUIVALENT REPRESENTATION OF SEVERAL ADAPTIVE SCHEMES

We present in this section several adaptive control laws that can be studied using the passivity result presented in the previous section. For each of them, we will demonstrate that:

- (1) they can be analysed as an interconnection of the three main subsystems in Figure 1;
- (2) the blocks B1 and B3 are strictly passive and passive respectively.

First, we show that the subsystem B2 which contains the robot dynamics is passive.

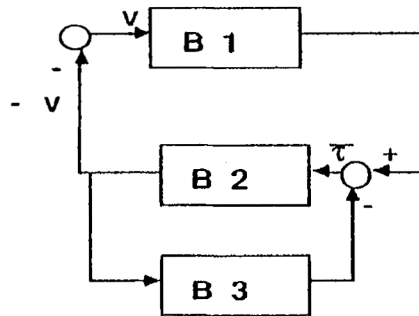

Figure 1. Closed-loop equivalent system

Passivity of the robot dynamics B2 block. We have

$$\bar{\tau} = -[M(q)\dot{v} + C(q, \dot{q})v]$$

Therefore

$$\begin{aligned} \langle \bar{\tau}, -v \rangle_T &= \int_0^T v^T \bar{\tau} dt = \int_0^T (v^T M(q)\dot{v} + v^T C(q, \dot{q})v) dt \\ &= \int_0^T \left\{ \frac{1}{2} \frac{d}{dt} (v^T M(q)v) - \frac{1}{2} v^T \dot{M}(q)v + v^T C(q, \dot{q})v \right\} dt \\ &= \frac{1}{2} \int_0^T \frac{d}{dt} (v^T M(q)v) dt + \int_0^T v^T \left(C(q, \dot{q}) - \frac{1}{2} \dot{M}(q) \right) v dt \end{aligned}$$

Knowing that $C(q, \dot{q}) - \frac{1}{2} \dot{M}(q)$ can be chosen as a skew-symmetric matrix (see, for example, Reference 17), we obtain

$$\langle \bar{\tau}, -v \rangle_T \geq -\frac{1}{2} v^T(0)M(q(0))v(0)$$

The remainder of the section will be organized as follows.

- (1) First we show that the adaptive laws proposed in References 6–8 can be treated together, in the sense that only the block B1 changes from one to another.
- (2) Then we perform a separate analysis for each law.^{9–14}

System equivalent representation of schemes proposed in References 6–8

We now consider the first three laws proposed in References 6–8. For each case the control law is given by

$$\tau = \hat{M}(q)\dot{a} + \hat{C}(q, \dot{q})a + \hat{g}(q) - H(v, \tilde{q}) \quad (6)$$

with $a = \dot{q}_d - \lambda \tilde{q}$, $v = \dot{\tilde{q}}$, $\lambda > 0$ where a is a signal resulting from an outloop control law: $a = a(q, \dot{q}, q_d, \dot{q}_d)$ and $(\hat{\cdot})$ represents the estimates of (\cdot) at time t and $(\tilde{\cdot}) = (\hat{\cdot}) - (\cdot)$. H is an operator to be defined later (see Reference 18 for details).

Substituting this control law into the robot dynamics, one gets the following error equation:

$$M(q)\dot{v} + C(q, \dot{q})v + H(v, \tilde{q}) = Y(q, \dot{q}, \dot{a}, a)\tilde{\theta} \quad (7)$$

where the three blocks B2, B1, and B3 clearly appear. The update law is given by:

$$\dot{\tilde{\theta}} = -\Gamma Y^T v \quad \Gamma = \Gamma^T > 0 \quad (8)$$

Passivity of the parameter estimation algorithm in the B3 block

$$\begin{aligned} \langle -v, Y\tilde{\theta} \rangle_T &= \int_0^T -v^T Y\tilde{\theta} dt \\ &= \int_0^T \dot{\tilde{\theta}}^T \Gamma^{-1} \tilde{\theta} dt \geq -\frac{1}{2} \tilde{\theta}^T(0)\Gamma^{-1}\tilde{\theta}(0) \end{aligned} \quad (9)$$

Where we simply use from (8) that:

$$v^T Y = -\dot{\tilde{\theta}}^T \Gamma^{-1}$$

So the mapping $-v \rightarrow Y\tilde{\theta}$ is passive.

Strict passivity of the BI block. It is sufficient that H be strictly passive for these adaptive laws to ensure the global asymptotic convergence of the tracking error. This is achieved by choosing in each case:

(1) *Scheme proposed in Reference 7.* In this case

$$H(\tilde{q}, v) = F_v v + F_p \tilde{q}, \quad \text{with } F_p, F_v > 0$$

so there exists a $\delta > 0$ such that

$$\langle v, F_v v + F_p \tilde{q} \rangle_T = \int_0^T (v^T F_v v + v^T F_p \tilde{q}) dt \geq \delta \|v\|_{2,T}^2 - \frac{1}{2} \tilde{q}^T(0) F_p \tilde{q}(0)$$

where $\|\cdot\|_{2,T}$ denotes the truncated L_2 norm.

(2) *Scheme proposed in Reference 8.* This time

$$H(\tilde{q}, v) = H(v) = \mu H^*(x)v$$

where $\mu > 0$, $H^*(x) = J^{-T} H(q) J^{-1}$ and x represents the cartesian co-ordinates. J is the square Jacobian matrix of the manipulator, assumed to be full-rank. In this case one needs the following additional assumption:

$$\text{there exists } \alpha > 0 \text{ such that } \alpha I \leq H^*(x)$$

Then

$$\langle v, \lambda H^*(x).v \rangle_T = \int_0^T v^T \lambda H^*(x)v dt \geq \lambda \alpha \|v\|_{2,T}^2$$

Remark. In case (2), the authors considered a unified approach of motion and force control in the cartesian space. The signal v is then defined by the following relation:

$$\dot{v} + \lambda v = -R[G(s)S\xi + (I - S)F(s)R^{-1}\tilde{F}]$$

where λ is a positive scalar, ξ is related to the tracking error $e = x_d - x$ and the measured force F by

$$\xi = R^{-1}e + \Lambda G(s)^{-1}R^{-1}F$$

Where Λ is a selection matrix: $\Lambda = 1$ or 0 , R is a constant matrix, $G(s)$ and $F(s)$ are transfer functions of degree 2, and S is the selection matrix, which is diagonal with elements being 1 or 0: the axis motion-controlled correspond to the '1', the others are force-controlled.

Then if $v \in L_2^n$, one can show that each component of $v = (v_1, v_2, \dots, v_n)$ is L_2 as well, so that lemma (Reference 16; p. 59) holds for each axis.

We are able to conclude

$$\begin{aligned} S\xi \text{ and } (I - S)R^{-1}\tilde{F} &\in L_2^n \cap L_\infty^n \\ S\dot{\xi} \text{ and } (I - S)R^{-1}\dot{\tilde{F}} &\in L_2^n \end{aligned}$$

Therefore

$$S\xi \text{ and } (I - S)R^{-1}\tilde{F} \text{ are continuous and tend towards zero as } t \rightarrow \infty$$

(3) *Scheme proposed in Reference 6.* In this case

$$H(v, \tilde{q}) = K_D v; K_D > 0$$

so there exists $\delta > 0$ such that:

$$\langle v, K_D v \rangle_T = \int_0^T v^T K_D v dt \geq \delta \|v\|_{2,T}^2$$

System equivalent representation of schemes proposed in References 9 and 10

In References 9 and 10 the authors have proposed a 'composite' adaptive law, with an update law utilizing both tracking and prediction errors. The control law is given as in (6) for $H(v, \tilde{q}) = K_D v$. Replacing it in the robot dynamics (1), one obtains (7). The update law is given by:

$$\dot{\Theta}(t) = -P(t)[Y^T v + \alpha(t)W^T e] \quad (10)$$

where e is the prediction error: $e = \hat{\tau}_f - \tau_f$ with τ_f the filtered torque obtained by

$$\tau_f = W(q, \dot{q}) \Theta$$

where $W(q, \dot{q}) = w(t)^* Y(q, \dot{q}, \tilde{q})$ and $w(t)$ is the impulse response of an exponentially stable, strictly proper filter.

Block B1 is identical to the previous case where $H(v, \tilde{q}) = K_D v$, and therefore is strictly passive. So we have only to prove that the update law defines a passive subsystem: choosing the most general algorithm (called, in Reference 9, inherently-bounded-gain method) we get:

$$\frac{d}{dt}(P^{-1}(t)) = -\lambda(t)[P^{-1}(t) - K_0^{-1}] + \alpha(t)W^T W \quad (11)$$

with $\lambda(t)$ and $\alpha(t)$ positive time-varying scalars; $K_0 > 0$.

$$\begin{aligned} \langle -v, Y\tilde{\theta} \rangle_T &= \int_0^T -\tilde{\theta}^T Y^T v dt = \int_0^T -\tilde{\theta}^T [-P^{-1}\dot{\tilde{\theta}} - \alpha W^T e] dt \\ &= \int_0^T \left\{ \tilde{\theta}^T \left[P^{-1}\dot{\tilde{\theta}} + \frac{d}{dt}(P^{-1})\tilde{\theta} \right] + \lambda \tilde{\theta}^T (P^{-1} - K_0^{-1})\tilde{\theta} \right\} dt \end{aligned}$$

But

$$P^{-1}\dot{\tilde{\theta}} + \frac{d}{dt}(P^{-1})\tilde{\theta} = \frac{d}{dt}(P^{-1}\tilde{\theta})$$

It follows that the first term in the integral can be written as:

$$\tilde{\theta}^T P^{-1} P \frac{d}{dt}(P^{-1}\tilde{\theta}) = u^T P \frac{du}{dt} = \frac{1}{2} \frac{d}{dt}(u^T P u) - \frac{1}{2} u^T \frac{dP}{dt} u$$

with $u = P^{-1}\tilde{\theta}$

Now using (11) and the following relation:

$$\frac{dP}{dt} = -P \frac{dP^{-1}}{dt} P$$

it follows that

$$u^T \frac{dP}{dt} u = \lambda u^T P [P^{-1} - K_0^{-1}] P u - \alpha u^T P W^T W P u$$

We finally get

$$\langle -v, Y\tilde{\theta} \rangle_T \geq \int_0^T \left\{ \frac{1}{2} \frac{d}{dt} (u^T P u) + \frac{\lambda}{2} \tilde{\theta}^T [P^{-1} - K_0^{-1}] \tilde{\theta} \right\} dt$$

as $P^{-1} - K_0^{-1} \geq 0$ we obtain

$$\langle -v, Y\tilde{\theta} \rangle_T \geq -\frac{1}{2} \tilde{\theta}^T(0) P^{-1}(0) \tilde{\theta}(0) \quad (12)$$

Remark. In Reference 9, the authors have considered separately several algorithms, from the simple gradient method to the inherently-bounded-gain method. It is straightforward to see that the IBG method is in fact the most general one, and that the other methods presented are particular cases of the IBG. For instance, by choosing $\lambda(t) = 0$ and $\alpha(T) = 1$, one obtains the standard-least-squares method; $K_0^{-1} = 0$ and $\lambda(t) = \lambda_0(1 - 1/k_0 \|P\|)$ leads to the gain-adjusted-forgetting method (GAF).

System equivalent representation of the scheme proposed in Reference 11

In Reference 11, the authors have proposed a so-called 'desired compensation adaptive law' (DCAL), which is based on the fact that the regressor is no longer a function of measured signals, but of desired trajectories, i.e.

$$\dot{\hat{\Theta}} = -\Gamma Y^T(q_d, \dot{q}_d, \ddot{q}_d) v = -\Gamma Y_d v \quad (13)$$

(For simplicity we will denote $Y(q_d, \dot{q}_d, \ddot{q}_d)$ by Y_d). It presents the advantage of being more computationally efficient, but leads to a more complex analysis.

The control law is given by

$$\tau = Y_d \hat{\Theta} - F_v v - F_p \tilde{q} - f(v, \tilde{q}) \quad (14)$$

with $f(v, \tilde{q}) = \sigma_n \|\tilde{q}\|^2 v$, σ_n, F_p and $F_v > 0$

where $f(v, \tilde{q})$ is an auxiliary nonlinear feedback term introduced to compensate the kinematic error due to Y_d in the update law. Replacing it in the robot dynamics leads to (7) with

$$H(v, \tilde{q}) = -F_p \tilde{q} - F_v v - f(v, \tilde{q}) - \Delta Y(v, \tilde{q}) \quad (15)$$

where $\Delta Y(v, \tilde{q}) = [Y(q, \dot{q}, \ddot{q}) - Y_d] \hat{\Theta}$.

The update law is a gradient, and therefore is passive.

Strict passivity of the block B1. One can show that, choosing F_v, F_p, σ_n , and λ large enough, one can obtain a strictly passive operator (see Appendix A for details).

System equivalent representation of schemes proposed in References 12 and 13

First, let us introduce a slight modification in the passivity theorem presented in Section 3. Assume that one is able to demonstrate passivity (or strict passivity), of any of the three blocks B1, B2, B3 only for a given set of instants $S = (T_i)_{i \in N}$, and not for all $T > 0$. Then the results of Section 3 will still hold. Indeed, it is straightforward to conclude that

$$\|v\|_{2T_i} < \infty \quad \text{for all } T_i \in S$$

Given any $T \geq 0$, there always exists a couple (T_i, T_{i+1}) such that $T_i \leq T \leq T_{i+1}$. Then

$$\int_0^{T_i} \|v(t)\|^2 dt \leq \int_0^T \|v(t)\|^2 dt \leq \int_0^{T_{i+1}} \|v(t)\|^2 dt < \infty$$

Then

$$\|v(t)\|_T < \infty \quad \text{for all } T > 0 \Rightarrow v \in L_2^n$$

and the rest of the analysis follows.

In Reference 12, the authors considered a ‘repetitive control law’, designed for robots which are required to execute the same motion with a fixed period t' , i.e.

$$\begin{aligned} q_d(t+t') &= q_d(t) \\ \dot{q}_d(t+t') &= \dot{q}_d(t) \\ \ddot{q}_d(t+t') &= \ddot{q}_d(t) \end{aligned}$$

The robot is expected to ‘learn’ the trajectory after consecutive iterations from a period to another. The repetitive control law is given by

$$\tau = \hat{w}_r(t) - F_v v - F_p \tilde{q} - f(\tilde{q}, v) \quad (16)$$

Where the last terms are identical to those of Reference 11 in the ‘DCAL’ algorithm, and

$$w_r(t) = Y(q_d, \dot{q}_d, \ddot{q}_d)\theta = Y_d \theta \quad (17)$$

Replacing it into the robot dynamics leads to

$$M(q)\dot{v} + C(q, \dot{q})v = -F_v v - F_p \tilde{q} - \Delta Y(\tilde{q}, v) - f(\tilde{q}, v) + \tilde{w}_r(t) \quad (18)$$

where the blocks B1, B2, B3 clearly appear. Note that the B1 block is identical to the one in Reference 11 and can be made strictly passive by appropriate choice of the gains in (16).

Passivity of block B3. In Reference 12, the authors introduced a projection operation to keep the estimates between lower and upper bounds, which are assumed to be known *a priori*, thus ensuring boundedness of the estimated $\hat{w}_r(t)$.

During phases of adaptation, the estimation algorithm is given by

$$\tilde{w}_r(t) = \tilde{w}_r(t-t') - K_L v(t) \quad K_L > 0$$

Assuming that there is no finite escape time and not taking into account the projection operation, one can show the passivity of the B3 block in this case too (see Appendix B for details).

Remark. The authors have also introduced¹³ a modification in their adaptation algorithm:

$$\tilde{w}_r(t) = \tilde{w}_r(t-t') - K_L v(t-t')$$

to allow sufficient time for computation. It can be shown that, adding a signal $-F_{v2}v$ to the B3 block (separating the gain F_v into two parts as done in Reference 13, this algorithm is also passive.

System equivalent representation of schemes proposed in References 14a and 14b

A new adaptation learning rule has been studied in Reference 14a. It presents the advantage that no projection operation is needed to keep the internal signals bounded. It is mainly based

on the fact that the unknown term $\tilde{w}_r(t)$ can be written as

$$\tilde{w}_r(t) = \int_0^{t'} K(t, \tau) \tilde{c}(t, \tau) d\tau \quad (19)$$

where $c(t, \tau)$ is an influence function, and $K(t, \tau)$ is a positive non-degenerate kernel (see Reference 14 for details). The update law is given by

$$\frac{\partial}{\partial t} \hat{c}(t, \tau) = -K_L K(t, \tau) v(t), \quad K_L = K_L^T > 0 \quad (20)$$

It is then possible to show that this learning rule is also passive (see Appendix C).

In order to reduce the on-line computations, the authors have also introduced a so-called delayed repetitive learning rule.^{14b} The influence function is now given by

$$\hat{c}_{k+1} = \hat{c}_k + \int_{(k-1)t'}^{kt'} K_L K(\sigma, \tau) v(\sigma) d\sigma \quad (21)$$

and the update law:

$$\hat{w}_r(t) = \int_0^{t'} K(t, \tau) \hat{c}_k(\tau) d\tau \quad (22)$$

for $kt' \leq t < (k+1)t', k = 1, 2, 3, \dots$

Assuming this time again there is no finite escape time (at least during the first period $0 \leq t < t'$), then one can show that this delayed algorithm is passive (see Appendix D).

5. STABILITY ANALYSIS

The foregoing studies have shown the global asymptotic convergence of the tracking error of the schemes considered. In order to complete the stability result, it only remains to state that all the signals in the equivalent feedback representation, including the estimates, are bounded. Similarly to what has been done in Reference 17, let us consider the following function:

$$V(T) = \gamma + \langle -v, \tilde{\tau} \rangle_T + \beta + \langle -v, Y\tilde{\theta} \rangle_T + \mu + \langle v, H(v, \tilde{q}) \rangle_T \quad (23)$$

Note that choosing γ, β and μ adequately ensures that V is a positive function, as we have shown previously that there exist $\gamma > 0, \beta > 0, \mu > 0$ and $\delta > 0$ such that for all $T > 0$

$$\langle -v, \tilde{\tau} \rangle_T \geq -\gamma, \langle -v, Y\tilde{\theta} \rangle_T \geq -\beta \quad \text{and} \quad \langle v, H(v, \tilde{q}) \rangle_T \geq \delta \|v\|_{2,T}^2 - \mu \geq -\mu$$

Choosing $\gamma = 1/2 v^T(0) M(q(0)) v(0)$, $V(T)$ can be rewritten as

$$V(T) = \frac{1}{2} v^T M(q) v + \beta + \int_0^T (-v^T Y\tilde{\theta}) dt + \mu + \int_0^T v^T H(v, \tilde{q}) dt \quad (24)$$

Differentiating V along the trajectories of the system leads to

$$\dot{V}(T) = 0 \quad \text{for all } T \geq 0$$

Hence one gets $V(T) = V(0)$ so $V \in L_\infty$ and then $V \in L_\infty^n$. Applying a similar result to the lemma in Section 3 (see Reference 17, p. 59) we get

$$\dot{\tilde{q}} \in L_\infty^n$$

and then $q, \dot{q}, a = a(q, \dot{q}, q_d, \dot{q}_d, \ddot{q}_d)$, $a = \dot{q} - v$ and $Y(q, \dot{q}, a, \dot{a})$ remain L_∞ -bounded.

(1) Schemes proposed in References 6–8 and 11. In these cases

$$\beta + \langle -v, Y\tilde{\theta} \rangle_T \geq \frac{1}{2} \tilde{\theta}^T(T) \Gamma \tilde{\theta}(T) \quad \text{so } \tilde{\theta} \in L_\infty^n \text{ and } Y\tilde{\theta} \in L_\infty^n$$

(where we have chosen $\beta = \frac{1}{2} \tilde{\theta}^T(0) \Gamma \tilde{\theta}(0)$).

(2) Schemes proposed in References 9 and 10. In this case one gets

$$\begin{aligned} \beta + \langle -v, Y\tilde{\theta} \rangle_T &= \int_0^T \left\{ \frac{1}{2} \frac{d}{dt} (u^T P u) + \frac{\lambda}{2} \tilde{\theta}^T [P^{-1} - K_0^{-1}] \tilde{\theta} \right\} dt \\ &\geq \frac{1}{2} \tilde{\theta}^T(T) P^{-1}(T) \tilde{\theta}(T) \geq 0 \quad (\text{as } P^{-1} - K_0^{-1} \geq 0) \end{aligned}$$

(where we have chosen $\beta = \frac{1}{2} \tilde{\theta}^T(0) P^{-1}(0) \tilde{\theta}(0)$). Hence

$$\tilde{\theta} \in L_\infty^m \text{ and } Y\tilde{\theta} \in L_\infty^n$$

Remark. We have shown that the closed-loop error equation can in each case be written as follows:

$$M(q)\dot{v} + C(q, \dot{q})v + H(v, \tilde{q}) = Y\tilde{\theta}$$

Then

$$\dot{v} = [M(q)]^{-1} [Y\tilde{\theta} - H(v, \tilde{q}) - C(q, \dot{q})v]$$

As the right-hand side of the expression above is bounded, one gets

$$\dot{v} \in L_\infty^n$$

Now, $\dot{\tilde{q}} = H(s)\dot{v}$; applying lemma (Reference 17, p. 59) one concludes:

$$\dot{\tilde{q}} \in L_\infty^n \cap L_2^n$$

$$\tilde{q} \in L_\infty^n$$

$\dot{\tilde{q}}$ is continuous and $\dot{\tilde{q}} \rightarrow 0$ as $t \rightarrow +\infty$

(3) Scheme proposed in Reference 12. Utilizing the same technique, we here replace $Y\tilde{\theta}$ by $\tilde{w}_r(t)$. Taking

$$\beta = \int_0^{t'} \|\tilde{w}_r(t)\|_{\tilde{K}_r^{-1}}^2 dt + \alpha$$

we obtain

$$\beta + \langle -v, \tilde{w}_r \rangle_{T_n} \geq \int_{(n-1)t'}^{nt'} \|\tilde{w}_r(t)\|_{\tilde{K}_r^{-1}}^2 dt \geq 0 \quad \text{for all } n \geq 2, \text{ with } T_n = nt'$$

It shows that \tilde{w}_r is $L_2[(n-1)t', nt']$ bounded. Hence, under the assumption that the algorithm does not diverge during the first period $0 \leq t \leq t'$, there is no finite escape time in the system. Unfortunately, L_∞ -boundedness cannot be ensured without a projection operation as done in Reference 12.

Moreover, boundedness of the several signals previously stated can no longer be ensured for all $t \geq 0$, as $V(T)$ is a positive definite function only for $T = T_n, n \in \mathcal{N}^*$. Note that as lemma in Section 3 still holds, one still gets

$$\tilde{q} \in L_\infty^n$$

Nevertheless, boundedness of the other signals for all $t \geq 0$ can be shown through a Lyapunov-type approach, as done in Reference 12.

(4) *Scheme proposed in Reference 14a.* We now choose

$$\beta = \frac{1}{2} \int_0^{t'} \tilde{c}(0, \tau)^T K_L^{-1} \tilde{c}(0, \tau) d\tau$$

Hence

$$\int_0^{t'} \|\tilde{c}(T, \tau)\|^2 d\tau \in L_\infty \quad \text{for all } T > 0$$

Following what has been done in Reference 14, this allows us to conclude on the boundedness of the estimated signals $w_r(t)$. Note also that, contrary to Reference 12, the analysis is done for all $T > 0$, and is not restricted to a set of discrete instants T_n . So the foregoing conclusions on the schemes of References 6–11 are available.

(5) *Scheme proposed in Reference 14b.* As for Reference 12, the passivity analysis of the update law has been done for a set of discrete instants T_n , and not for all $T > 0$. So the conclusions are equivalent. However, because of the particular form of the update law (21) and (22), and using the fact that $v \in L_2$, the estimates are bounded.

Remark. Concerning adaptation algorithms, one can note that the gradient method is wide spread in robot adaptive control, as can easily be seen as a passive map between its input and output. In Reference 15, the authors have exhibited a class of passive adaptation algorithms, known as the ‘integral + proportional PAA’, which had been first proposed in Reference 20, but never applied in the field of robot control.

In fact, though least-squares algorithms are recognized as ensuring better performances than the gradient method, one is only able to establish the passivity of the latter. In Reference 19, the authors have recently introduced a modified least-squares estimation algorithm based on passivity properties: Their control law is given by

$$\tau = \hat{M}(q)\dot{a} + \hat{C}(q, \dot{q})a + \hat{g}(q) - Kv$$

a resulting from an outloop control law as in Section 4 of this paper (see References 24 and 19 for further details). Replacing it in the robot dynamics leads to

$$M(q)\dot{v} + C(q, \dot{q})v = Y(q, \dot{q}, a, \dot{a})\tilde{\theta} - Kv$$

The modified least-squares algorithm is given by

$$\hat{\theta} = \hat{\theta}_L + s \quad \text{and} \quad \dot{\hat{\theta}}_L = -PY^T v$$

with

$$s = \frac{-Y^T}{1 + \text{tr}(Y^T Y)} \frac{v}{1 + v^T v} (\hat{\theta}_L^T A \hat{\theta}_L + M(1 + \lambda \lambda_{\max}(R)))$$

$$\dot{P} = \alpha(t) \left[-P \left\{ \frac{Y^T Y}{1 + \text{tr}(Y^T Y)} + \lambda R \right\} P + \lambda P \right]$$

$$\alpha(t) = \frac{v^T Y Y^T v}{(1 + v^T v)[1 + \text{tr}(Y^T Y)]}$$

$$A = \frac{Y^T Y}{1 + \text{tr}(Y^T Y)} + \lambda R$$

with $\lambda \geq 0$ and $R > 0$; $\lambda_{\min}(R) \leq P^{-1}(0) \leq \lambda_{\max}(R) + 1/\lambda$, where s is the modification to the least squares estimate that renders the mapping $-v \rightarrow Y\theta$ passive (see References 19 and 24 for details).

6. CONCLUSION

In this paper, we have shown that most of the direct continuous adaptive control laws proposed to date for rigid manipulators can be analysed through a passivity approach, and that the simple framework proposed enables simplifications to be made of certain analyses and provides a clear understanding of such algorithms.

One can now legitimately expect this different point of view to result in new algorithms designed directly from the passivity theorem. In fact, it has been shown that the passivity approach can lead to new adaptive control laws in the case of hybrid force/position control (see, for example, References 22 and 23 where extensions of the motion control laws in References 6 and 8 respectively have been proposed). Note also that some adaptive schemes recently proposed in the literature (see, for example, Reference 25) can be analysed through a passive point of view, although their structure slightly differs from the one presented here (namely, no use of property (3) in Section 2 is done in Reference 25). It has also to be emphasized that the study in this paper can be viewed as a particular (but important) case of the more general study concerning relationships between Lyapunov functions and passivity tools presented in Reference 26.

APPENDIX A: *Strict passivity of the B1 block*

In this case, we can write

$$\langle -v, H(v, \tilde{q}) \rangle_T = \int_0^T v^T [F_v v + F_p \tilde{q} + \sigma_n \|\tilde{q}\|^2 v + \Delta Y(v, \tilde{q})] dt$$

The proof mainly hinges on the following relation (see Reference 11 for details):

$$v^T \Delta Y(v, \tilde{q}) \geq -v^T [\lambda M(q) + b_1 I] v - v^T [-\lambda^2 M(q) + b_2 I] \tilde{q} - b_3 [\|v\|^2 \|\tilde{q}\| + \lambda \|v\| \|\tilde{q}\|^2]$$

with

$$\begin{aligned} b_1 &= b_1(\dot{q}_d) \geq 0 \\ b_2 &= b_2(\dot{q}_d, \ddot{q}_d) \geq 0 \\ b_3 &\geq 0 \end{aligned}$$

Then we can write:

$$\begin{aligned} \langle v, H(v, \tilde{q}) \rangle_T &\geq \int_0^T \{ \sigma_v v^T v + \sigma_p v^T \tilde{q} + \sigma_n \|\tilde{q}\|^2 \|v\|^2 - v^T [\lambda M(q) + b_1 I] v \\ &\quad - \int_0^T \{ v^T [-\lambda^2 M(q) + b_2 I] \tilde{q} - b_3 [\|v\|^2 \|\tilde{q}\| + \lambda \|v\| \|\tilde{q}\|^2] \} dt \end{aligned}$$

As it has been done in Reference 11, the last term in the integral can be written:

$$\begin{aligned} b_3 [\|v\|^2 \|\tilde{q}\| + \lambda \|v\| \|\tilde{q}\|^2] &= \frac{b_3}{4} \|v\|^2 + \lambda \frac{b_3}{4} \|\tilde{q}\|^2 - b_3 \|v\|^2 \left[\frac{1}{2} - \|\tilde{q}\| \right]^2 \\ &\quad - \lambda b_3 \|\tilde{q}\|^2 \left[\frac{1}{2} - \|v\| \right]^2 + (1 + \lambda) b_3 \|v\|^2 \|\tilde{q}\|^2 \end{aligned}$$

Grouping similar quadratic terms together,

$$\begin{aligned} \langle v, H(v, \tilde{q}) \rangle_T \geq & \int_0^T v^T \left[\left(\sigma_p - b_1 - \frac{b_3}{4} \right) I - \lambda M(q) \right] v \, dt + \int_0^T \|v\|^2 \|\tilde{q}\|^2 [\sigma_n - (1 + \lambda) b_3] \, dt \\ & + \int_0^T \left\{ v^T [(\sigma_p - b_2)I + \lambda^2 M(q)] \tilde{q} - \lambda \frac{b_3}{4} \|\tilde{q}\|^2 \right\} dt \end{aligned}$$

But

$$\begin{aligned} v^T [(\sigma_p - b_2)I + \lambda^2 M(q)] \tilde{q} &= \lambda_p^2 \sigma_p \|\tilde{q}\|^2 + \sigma_p \tilde{q}^T \dot{\tilde{q}} + v^T [\lambda^2 M(q) - b_2 I] \tilde{q} \\ &\geq \lambda \sigma_p \|\tilde{q}\|^2 + \frac{\sigma_p}{2} \frac{d}{dt} (\tilde{q}^T \tilde{q}) - \frac{1}{2} v^T [\lambda^2 M(q) - b_2 I] v - \frac{1}{2} \tilde{q}^T [\lambda^2 M(q) - b_2 I] \tilde{q} \end{aligned}$$

Finally we obtain

$$\begin{aligned} \langle v, H(v, \tilde{q}) \rangle_T \geq & \int_0^T v^T \left[\left(\sigma_v - b_1 + \frac{b_2}{2} - \frac{b_3}{4} \right) I - \lambda M(q) - \frac{\lambda^2}{2} M(q) \right] v \, dt \\ & + \int_0^T \tilde{q}^T \left[\left(\lambda \sigma_p + \frac{b_2}{2} - \lambda \frac{b_3}{4} \right) \left(I - \frac{\lambda^2}{2} M(q) \right) \right] \tilde{q} \, dt \\ & + \int_0^T \|v\|^2 \|\tilde{q}\|^2 [\sigma_n - (1 + \lambda) b_3] \, dt - \frac{\sigma_p}{2} \|\tilde{q}(0)\|^2 \end{aligned}$$

We are now able to claim that, provided F_p , F_v , σ_n and λ are chosen so that the following relations are satisfied:

$$\begin{aligned} F_p = \sigma_p I &\geq \frac{1}{\lambda} \left[\left(-\frac{b_2}{2} + \lambda \frac{b_3}{4} \right) I + \frac{\lambda^2}{2} M(q) \right] \\ F_v = \sigma_v I &\geq \left(b_1 - \frac{b_2}{2} + \frac{b_3}{4} \right) I + \lambda \left(1 + \frac{\lambda}{2} \right) M(q) \\ \sigma_n &\geq (1 + \lambda) b_3 \end{aligned}$$

Then the block B1 is a passive one. Moreover, if σ_v is chosen large enough, there exists a $\delta > 0$ such that:

$$\langle v, H(v, \tilde{q}) \rangle_T \geq \delta \|v\|_{2,T}^2 - \mu \quad \text{with } \mu = \frac{\sigma_p}{2} \|\tilde{q}(0)\|^2$$

and the block B1 is then strictly passive.

APPENDIX B: Passivity of the B3 block

For all $T_n = nt'$, $n \in \mathbb{N}^*$, one gets

$$\langle -v(t), \tilde{w}_r(t) \rangle_{T_n} = \sum_{k=0}^{n-1} \int_{kt'}^{(k+1)t'} -v^T \tilde{w}_r(t) \, dt = \sum_{k=0}^{n-1} \int_{kt'}^{(k+1)t'} -v^T \tilde{w}_r \, dt - \int_0^{t'} v^T \tilde{w}_r \, dt$$

We will assume now that there is no finite escape time in this algorithm so that the last integral term of the expression above is bounded:

$$\text{there exists } \alpha > 0 \text{ such that } \left| \int_0^{t'} v^T \tilde{w}_r \, dt \right| \leq \alpha < \infty$$

Then

$$\langle -v(t), \tilde{w}_r(t) \rangle_{T_n} \geq \sum_{k=1}^{n-1} \int_{kt'}^{(k+1)t'} -v^T \tilde{w}_r(t) \, dt - \alpha$$

As it has been done in Reference 12, the term under the integral can be rewritten

$$-v^T(t) \tilde{w}_r(t) = \frac{1}{2} [\tilde{w}_r^T(t) K_L^{-1} \tilde{w}_r^T(t) - \tilde{w}_r^T(t-t') K_L^{-1} \tilde{w}_r(t-t') + v^T(t) K_L v(t)]$$

Replacing this expression in the integral leads to

$$\langle -v, \tilde{w}_r \rangle_{T_n} \geq \sum_{k=1}^{n-1} \int_{kt'}^{(k+1)t'} \{ \|\tilde{w}_r(t)\|_{\tilde{K}_L^{-1}}^2 - \|\tilde{w}_r(t-t')\|_{\tilde{K}_L^{-1}}^2 \} dt - \alpha$$

Introducing the following variable change in the second term in the integral

$$u = t - t' \quad du = dt$$

one gets

$$\langle -v, \tilde{w}_r \rangle_{T_n} \geq \sum_{k=1}^{n-1} \left[\int_{kt'}^{(k+1)t'} \|\tilde{w}_r(t)\|_{\tilde{K}_L^{-1}}^2 dt - \int_{(k-1)t'}^{kt'} \|\tilde{w}_r(u)\|_{\tilde{K}_L^{-1}}^2 du \right] - \alpha$$

Noticing that all the terms under the integrals cancel but for the following ones:

$$\int_{(n-1)t'}^{nt'} \|\tilde{w}_r(t)\|_{\tilde{K}_L^{-1}}^2 dt \quad \text{and} \quad \int_0^{t'} \|\tilde{w}_r(t)\|_{\tilde{K}_L^{-1}}^2 dt$$

we obtain

$$\begin{aligned} \langle -v, \tilde{w}_r \rangle_{T_n} &\geq \int_{(n-1)t'}^{nt'} \|\tilde{w}_r(t)\|_{\tilde{K}_L^{-1}}^2 dt - \int_0^{t'} \|\tilde{w}_r(u)\|_{\tilde{K}_L^{-1}}^2 du - \alpha \\ &\geq - \int_0^{t'} \|\tilde{w}_r(u)\|_{\tilde{K}_L^{-1}}^2 du - \alpha \end{aligned}$$

Making the same assumption on the first period as previously, one sees that the estimation algorithm is passive for all T_n .

APPENDIX C: *Passivity of the B3 block*

$$\langle -v, \tilde{w}_r \rangle_T = \int_0^T -v^T \int_0^{t'} K(t, \tau) \tilde{c}(t, \tau) d\tau dt = \int_0^T \int_0^{t'} \left[\frac{\partial}{\partial t} \tilde{c}(t, \tau) \right]^T K_L^{-1} \tilde{c}(t, \tau) d\tau dt$$

which follows from the fact that

$$\frac{\partial}{\partial t} \tilde{c}(t, \tau) = \frac{\partial}{\partial t} \tilde{c}(t, \tau)$$

Then we obtain:

$$\begin{aligned} \langle -v, \tilde{w}_r \rangle_T &= \frac{1}{2} \left\{ \int_0^{t'} \tilde{c}(T, \tau)^T K_L^{-1} \tilde{c}(T, \tau) dt - \int_0^{t'} \tilde{c}(0, \tau)^T K_L^{-1} \tilde{c}(0, \tau) d\tau \right\} \\ &\geq -\frac{1}{2} \int_0^{t'} \tilde{c}(0, \tau)^T K_L^{-1} \tilde{c}(0, \tau) d\tau \\ &\geq -\frac{1}{2\sigma_{\max}(K_L)} \int_0^{t'} \|\tilde{c}(0, \tau)\|^2 d\tau \end{aligned}$$

Hence, with the assumption that no finite escape occurs during the first time period, the update law defines a passive subsystem.

APPENDIX D:

$$\langle -v, \tilde{w}_r \rangle_{T_n} = \int_0^{t'} -v^T \tilde{w}_r dt - \int_{t'}^{T_n} -v^T \tilde{w}_r dt$$

with $T_n = nt'$.

The first term of the left-hand side is bounded. We shall now focus on the second one.

$$- \int_{t'}^{T_n} -v^T \tilde{w}_r dt = - \sum_{k=2}^n \int_0^{t'} \tilde{c}_{k-1}^T(\tau) \int_{(k-1)t'}^{kt'} K(t, \tau) v(t) dt d\tau$$

Now

$$-\tilde{c}_{k-1}(\tau) = -\tilde{c}(1) + \sum_{i=1}^{k-2} \int_{(i-1)t'}^{it'} K_L K(\tau, \sigma) v(\sigma) d\sigma$$

Let us define

$$x(i) = \int_{(i-1)t'}^{it'} K_L^{1/2} K(\tau, \sigma) v(\sigma) d\sigma$$

Then we obtain:

$$\int_0^{T_n} -v^T \tilde{w}_r dt = \int_0^{t'} \sum_{k=2}^n x^T(k) \left[\sum_{i=1}^{k-2} x(i) - K_L^{-1/2} \tilde{c}_1 \right] d\tau$$

Now we use the fact that:

$$\begin{aligned} \sum_{k=2}^n x^T(k) \left[\sum_{i=1}^{k-2} x(i) - K_L^{-1/2} \tilde{c}_1 \right] &= \sum_{k=1}^n x^T(k) \left[\sum_{i=1}^k x(i) - K_L^{-1/2} \tilde{c}_1 \right] \\ &\quad - \sum_{k=2}^n x^T(k) [x(k) + x(k-1)] - x^T(1) [x(1) - K_L^{-1/2} \tilde{c}_1] \end{aligned}$$

and the following lemma.²⁰

Lemma

Given a sequence of real vectors $x(k)$ and a constant vector c , then the following relation is true:

$$\sum_{k=1}^n x^T(k) \left[\sum_{i=1}^k x(i) + c \right] \geq -\frac{1}{2} c^T c$$

For all $n \geq 1$. □

Hence we obtain

$$\langle -v, \tilde{w}_r \rangle_{T_n} \geq -a - \int_0^{t'} \left\{ \tilde{c}_1^T K_L^{-1} \tilde{c}_1 + \frac{3}{2} x^T(1)x(1) \right\} d\tau - \int_0^{t'} \sum_{k=2}^n \left\{ x^T(k)x(k) + x^T(k)x(k-1) \right\} d\tau$$

The second term of the right-hand side is bounded. Recalling the definition of $x(k)$, the third term can be written as:

$$- \int_0^{t'} \sum_{k=2}^n \{ x^T(k)x(k) + x^T(k)x(k-1) \} d\tau \geq -2 \sum_{k=1}^n \int_{(k-1)t'}^{kt'} v^T(t) x K_L v(t) dt$$

where

$$x = \int_0^{t'} \|K(\tau, \sigma)\|^2 d\tau$$

(see References 13 and 14 for further details). Then we get

$$\langle -v, \tilde{w}_r \rangle_{T_n} \geq -\alpha - \gamma - 2 \sum_{k=1}^n \int_{(k-1)t'}^{kt'} v^T(t) x K_L v(t) dt$$

where α and γ stand for the upper bounds of the initial terms. One can easily see that it is sufficient now to add an auxiliary signal $-F_{v2}v$ to \tilde{w}_r in order to obtain a passive subsystem, provided the following condition is fulfilled: $F_{v2} - 2xK_L > 0$.

REFERENCES

1. Hsia, T. C., 'Adaptive control of robot manipulators: a review', *IEEE International Conference on Robotics and Automation*, San Francisco, 1986.
2. Craig, J. J., Pl. Hsu, and S. Sastry, 'Adaptive control of mechanical manipulators', *IEEE International Conference on Robotics and Automation*, San Francisco, 1986.
3. Spong, M. W., and R. Ortega, 'On adaptive inverse dynamics control of rigid robots', *IEEE Transactions on Automatic Control*, **35**, 92-95 (1990).

4. Amestegui, M., R. Ortega, and J. M. Ibarra, 'Adaptive linearizing decoupling robot control: a comparative study of different parametrization', *Proceedings of the 5th Yale Workshop on Applications of Adaptive Systems*, New Haven, CT, 1987.
5. Craig, J. J., *Adaptive Control of Mechanical Manipulators*, Addison-Wesley, Reading, MA, 1988.
6. Slotine, J. J., and W. Li, 'Adaptive manipulator control: a case study', *IEEE Transactions on Automatic Control*, **33**, 995–1003 (1988).
7. Sadegh, N., and R. Horowitz, 'Stability analysis of adaptive controller for robotic manipulators', *IEEE International Conference on Robotics and Automation*, Raleigh, NC, 1987.
8. Kelly, R., and R. Carelli, 'Unified approach to adaptive control of robotic manipulators', *Proceedings of the 24th Conference on Decision and Control*, Austin, TX, 1988.
9. Slotine, J. J., and W. Li, 'Composite adaptive control of robot manipulators', *Automatica*, **25**, 509–520 (1989).
10. Slotine, J. J., and W. Li, 'On the adaptive control of robot manipulators', *International Journal of Robotics Research*, **6**, 49–59 (1987).
11. Sadegh, N., and R. Horowitz, 'Stability and robustness analysis of a class of adaptive controllers for robotic manipulators', *International Journal of Robotics Research*, **9**, 74–92 (1990).
12. Sadegh, N., R. Horowitz, W. W. Kao, and M. Tomizuka, 'A unified approach to design of adaptive and repetitive controllers for robotic manipulators', presented at the USA–Japan symposium on flexible automation, Minneapolis, MN, 1988.
13. Horowitz, R., W. W. Kao, M. Boals, and N. Sadegh, 'Digital implementation of repetitive controllers for robotic manipulators', presented at the 1989 IEEE International Conference on Robotics and Automation, Phoenix, AZ, 1989.
14. Messner, W., R. Horowitz, W. W. Kao, and M. Boals, 'A new adaptive learning rule', presented (a) at the 1989 SIAM Conference in the Nineties, and (b) at the 1990 IEEE International Conference on Robotics and Automation, Cincinnati, Ohio, 1989.
15. Landau, I. D., and R. Horowitz, 'Synthesis of adaptive controllers for robot manipulators using a passive feedback systems approach', *International Journal of Adaptive Control and Signal Processing*, **3**, 23–38 (1989).
16. Desoer, C., and M. Vidyasagar, *Feedback Systems: Input–Output Properties*, Academic Press, New York, 1975.
17. Ortega, R., and M. W. Spong, 'Adaptive motion control of rigid robots: a tutorial', *Automatica*, **25**, (1989).
18. Slotine, J. J. E., 'Putting physics in control', *Colloque Systèmes Non Linéaires*, CNRS, 13–17 June, Nantes, France, 1988.
19. Lozano-Leal, R., and C. Canudas de Wit, 'Passivity based adaptive control for mechanical manipulators using LS type estimation', *IEEE Transactions on Automatic Control*, **35**, 1363–1365 (1990).
20. Landau, I. D., *Adaptive Control: the Model Reference Approach*, Dekker, New York, 1979.
21. Vidyasagar, M., 'Input–output analysis of large scale interconnected systems: decomposition, well-posedness and stability', Springer-Verlag, New York, 1981.
22. Lozano-Leal, R., and B. Brogliato, 'Adaptive hybrid force/position control for redundant manipulators', *IEEE Transactions on Automatic Control*, (1992), in press.
23. Carelli, R., and R. Kelly, 'An adaptive impedance/force controller for robot manipulators', *IEEE Transactions on Automatic Control*, **36**, 967–971 (1991).
24. Brogliato, B., and R. Lozano-Leal, 'Passive least-squares type estimation algorithm for direct adaptive control', *4th Latin-American Congress on Automatics, IFAC/AMCA*, Puebla, November, 1990.
25. Johansson, R., 'Adaptive control of robot manipulator motion', *IEEE Transactions on Robotics and Automation*, **6**, 483–490 (1990).
26. Lozano-Leal, R., B. Brogliato, and I. D. Landau, 'Passivity and global stabilization of cascaded nonlinear systems', *IEEE Transactions on Automatic Control*, (1992), in press.