



HAL
open science

Scattering by finely-layered obstacles: frequency-explicit bounds and homogenization

Théophile Chaumont-Frelet, Euan A Spence

► **To cite this version:**

Théophile Chaumont-Frelet, Euan A Spence. Scattering by finely-layered obstacles: frequency-explicit bounds and homogenization. *SIAM Journal on Mathematical Analysis*, 2023, 55 (2), pp.1319-1363. 10.1137/21M1450136 . hal-03354770

HAL Id: hal-03354770

<https://inria.hal.science/hal-03354770v1>

Submitted on 26 Sep 2021

HAL is a multi-disciplinary open access archive for the deposit and dissemination of scientific research documents, whether they are published or not. The documents may come from teaching and research institutions in France or abroad, or from public or private research centers.

L'archive ouverte pluridisciplinaire **HAL**, est destinée au dépôt et à la diffusion de documents scientifiques de niveau recherche, publiés ou non, émanant des établissements d'enseignement et de recherche français ou étrangers, des laboratoires publics ou privés.



Distributed under a Creative Commons Attribution 4.0 International License

Scattering by finely-layered obstacles: frequency-explicit bounds and homogenization

T. Chaumont-Frelet*, E. A. Spence†

September 26, 2021

Abstract

We consider the scalar Helmholtz equation with variable, discontinuous coefficients, modelling transmission of acoustic waves through an anisotropic penetrable obstacle. We first prove a well-posedness result and a frequency-explicit bound on the solution operator, with both valid for sufficiently-large frequency and for a class of coefficients that satisfy certain monotonicity conditions in one spatial direction, and are only assumed to be bounded (i.e., L^∞) in the other spatial directions. This class of coefficients therefore includes coefficients modelling transmission by penetrable obstacles with a (potentially large) number of layers (in 2-d) or fibres (in 3-d). Importantly, the frequency-explicit bound holds uniformly for all coefficients in this class; this uniformity allows us to consider highly-oscillatory coefficients and study the limiting behaviour when the period of oscillations goes to zero. In particular, we bound the H^1 error committed by the first-order bulk correction to the homogenized transmission problem, with this bound explicit in both the period of oscillations of the coefficients and the frequency of the Helmholtz equation; to our knowledge, this is the first homogenization result for the Helmholtz equation that is explicit in these two quantities and valid without the assumption that the frequency is small.

Keywords: Helmholtz equation, high frequency, transmission problem, homogenization

AMS subject classifications: 35B27, 35J05, 35P25, 78M40

1 Introduction

1.1 Definition of the Helmholtz transmission problem

For $R > 0$, let $B_R := \{\mathbf{x} \in \mathbb{R}^d \mid |\mathbf{x}| < R\}$ and let $\Gamma_R := \partial B_R = \{\mathbf{x} \in \mathbb{R}^d \mid |\mathbf{x}| = R\}$. Let $\text{DtN}_k : H^{1/2}(\Gamma_R) \rightarrow H^{-1/2}(\Gamma_R)$ be the Dirichlet-to-Neumann map for the equation $\Delta u + k^2 u = 0$ posed in the exterior of B_R with the Sommerfeld radiation condition

$$\frac{\partial u}{\partial r}(\mathbf{x}) - ik u(\mathbf{x}) = o\left(\frac{1}{r^{(d-1)/2}}\right) \quad (1.1)$$

as $r := |\mathbf{x}| \rightarrow \infty$, uniformly in $\hat{\mathbf{x}} := \mathbf{x}/r$. The definition of DtN_k in terms of Hankel functions and polar coordinates (when $d = 2$)/spherical polar coordinates (when $d = 3$) is given in, e.g., [21, Equations 3.5 and 3.6] [66, §2.6.3], [54, Equations 3.7 and 3.10].

Let Sym denote the set of $d \times d$ real, symmetric matrices and let SPD denote the set of $d \times d$ real, symmetric, positive-definite matrices. Given $M_1, M_2 \in \text{SPD}$ we write $M_1 \preceq M_2$ to indicate inequality in the sense of quadratic forms, namely $M_1 \mathbf{v} \cdot \bar{\mathbf{v}} \leq M_2 \mathbf{v} \cdot \bar{\mathbf{v}}$ for all $\mathbf{v} \in \mathbb{C}^d$. For a non-negative scalar m and $M \in \text{SPD}$ we write $m \preceq M$ if $mI \preceq M$, and $M \preceq m$ if $M \preceq mI$, where I is the identity matrix.

We now give the weak form of the variable coefficient Helmholtz equation

$$\nabla \cdot (A \nabla u) + k^2 n u = -f. \quad (1.2)$$

*Inria, 2004 Route des Lucioles, 06902 Valbonne, France, and Laboratoire J.A. Dieudonné, Parc Valrose, 28 Avenue Valrose, 06000 Nice, France, theophile.chaumont@inria.fr

†Department of Mathematical Sciences, University of Bath, Bath, BA2 7AY, UK, E.A.Spence@bath.ac.uk

Definition 1.1 (Helmholtz transmission problem) Given $R > R_0 > 0$,

- $n \in L^\infty(\mathbb{R}^d, \mathbb{R})$ with $\text{supp}(1 - n) \subset B_{R_0}$ and such that

$$0 < n_{\min} \leq n(\mathbf{x}) \leq n_{\max} < \infty \quad \text{for almost every } \mathbf{x} \in \mathbb{R}^d, \quad (1.3)$$

- $\mathbf{A} \in L^\infty(\mathbb{R}^d, \text{SPD})$ with $\text{supp}(1 - \mathbf{A}) \subset B_{R_0}$ and such that

$$0 < A_{\min} \preceq \mathbf{A}(\mathbf{x}) \preceq A_{\max} < \infty \quad \text{for almost every } \mathbf{x} \in \mathbb{R}^d, \quad (1.4)$$

- $F \in (H^1(B_R))'$,

and $k > 0$, we say that $u \in H^1(B_R)$ satisfies the Helmholtz transmission problem if

$$b(u, w) = F(w) \quad \text{for all } w \in H^1(B_R), \quad (1.5)$$

where

$$b(v, w) := \int_{B_R} \left((\mathbf{A} \nabla v) \cdot \overline{\nabla w} - k^2 n v \overline{w} \right) - \langle \text{DtN}_k v, w \rangle_{\Gamma_R}, \quad (1.6)$$

where $\langle \cdot, \cdot \rangle_{\Gamma_R}$ denotes the duality pairing on Γ_R that is linear in the first argument and antilinear in the second.

An important special case of the Helmholtz transmission problem of Definition 1.1 is transmission through a (not necessarily connected) Lipschitz penetrable obstacle, given in the following lemma. We first introduce some notation. Let $D_{\text{in}} \subset \mathbb{R}^d$, $d = 2$ or 3 , be a bounded open set such that $D_{\text{out}} := \mathbb{R}^d \setminus \overline{D_{\text{in}}}$ is connected. For any $\varphi \in L^2_{\text{loc}}(\mathbb{R}^d)$, we write $\varphi_{\text{in}} := \varphi|_{D_{\text{in}}}$ and $\varphi_{\text{out}} := \varphi|_{D_{\text{out}}}$. Let $\Gamma := \partial D_{\text{in}} = \partial D_{\text{out}}$. When Γ is Lipschitz, we let \mathbf{n} denote the unit normal vector field on Γ pointing from D_{in} into D_{out} , $\partial_{\mathbf{n}}$ denote the corresponding Neumann trace on Γ , and $\partial_{\mathbf{n}, \mathbf{A}}$ denote the corresponding conormal-derivative trace (for $\mathbf{A} \in L^\infty(\mathbb{R}^d, \text{SPD})$); we do not use any notation for the Dirichlet trace on Γ .

Lemma 1.2 (Definition 1.1 includes transmission by a Lipschitz penetrable obstacle)

Let D_{in} , D_{out} , and Γ be as above, and assume further that Γ is Lipschitz. Let $f \in L^2(\mathbb{R}^d)$ with $\text{supp} f \subset B_R$, and let $g_N \in L^2(\Gamma)$. If \mathbf{A} and n in Definition 1.1 are such that

$$\text{supp}(1 - \mathbf{A}) = \text{supp}(1 - n) = D_{\text{in}} \quad \text{and} \quad F(w) = \int_{B_R} f \overline{w} - \int_{\Gamma} g_N \overline{w},$$

then the solution u of the Helmholtz transmission problem of Definition 1.1 is the restriction to B_R of $v \in H^1_{\text{loc}}(\mathbb{R}^d)$ satisfying the Sommerfeld radiation condition (1.1) (with u replaced by v) and

$$\Delta v_{\text{out}} + k^2 v_{\text{out}} = -f_{\text{out}} \text{ in } D_{\text{out}}, \quad \nabla \cdot (\mathbf{A} \nabla v_{\text{in}}) + k^2 n v_{\text{in}} = -f_{\text{in}} \text{ in } D_{\text{in}}, \quad (1.7a)$$

$$\text{and} \quad v_{\text{out}} = v_{\text{in}} \quad \text{and} \quad \partial_{\mathbf{n}} v_{\text{out}} = \partial_{\mathbf{n}, \mathbf{A}} v_{\text{in}} + g_N \text{ on } \Gamma, \quad (1.7b)$$

References for proof. This follows by combining, e.g., [53, Lemma 4.19] (to obtain the PDEs in (1.7a) and the jump relations in (1.7b)) and, e.g., [38, Lemma 3.3] (to obtain that v satisfies radiation condition (1.1)). \blacksquare

Remark 1.3 (Choice of parameters for transmission by a single penetrable obstacle)

When n is constant, \mathbf{A} is a constant scalar, and D_{in} is connected, the classical transmission problem (1.7) is governed by two free parameters. By rescaling $v_{\text{in}}, v_{\text{out}}, f_{\text{in}}, f_{\text{out}}$ and k , (1.7) covers all other problems involving transmission by a penetrable obstacle described by constant real (scalar) coefficients; see [59, Text after Definition 2.3].

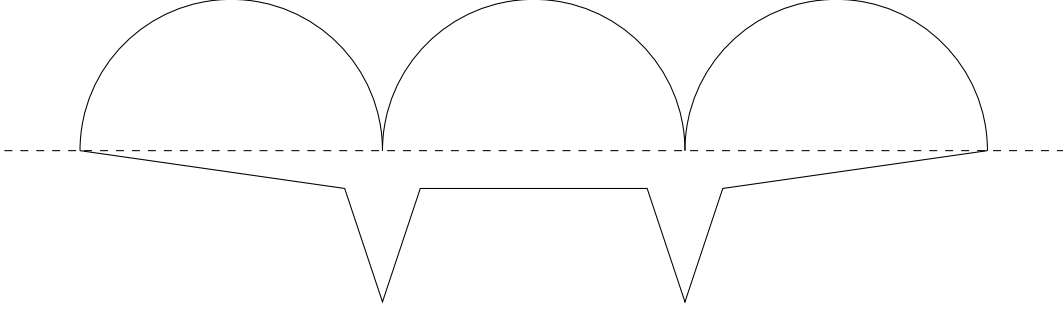

Figure 1.1: An example of a domain D_{in} satisfying the first bullet point in Example 1.5

1.2 Main result I: existence, uniqueness, and a priori bound on particular Helmholtz transmission problem

1.2.1 Statement of the result

For $\mathbf{x} \in \mathbb{R}^d$, we write $\mathbf{x} = (\mathbf{x}', x_d)$ with $\mathbf{x}' \in \mathbb{R}^{d-1}$ and $x_d \in \mathbb{R}$.

Condition 1.4 A and n satisfy the conditions in Definition 1.1. Additionally, A is such that

$$x_d [A(\mathbf{x} + h\mathbf{e}_d) - A(\mathbf{x})] \preceq 0 \quad \text{for all } h \geq 0 \text{ and for all } \mathbf{x} \in \mathbb{R}^d \quad (1.8)$$

and $(A)_{d\ell}(\mathbf{x}) = (A)_{\ell d}(\mathbf{x}) = 0$ for $\ell = 1, \dots, d-1$ and for all $\mathbf{x} \in \mathbb{R}^d$, and n is such that

$$x_d [n(\mathbf{x} + h\mathbf{e}_d) - n(\mathbf{x})] \geq 0 \quad \text{for all } h \geq 0 \text{ and for all } \mathbf{x} \in \mathbb{R}^d. \quad (1.9)$$

We make three remarks: (i) The monotonicity conditions (1.8) and (1.9) (i.e. that A decreases with distance from $x_d = 0$ and n increases) along with the assumptions that $\text{supp}(I - A)$ and $\text{supp}(1 - n)$ are compact imply that $A_{\min} \geq 1$ and $n_{\max} \leq 1$. (ii) Condition 1.4 only imposes constraints on the behaviour of A and n in the x_d direction, while the behaviour in the \mathbf{x}' directions is unconstrained. (iii) The origin of the condition that $(A)_{d\ell}(\mathbf{x}) = 0$ for $\ell = 1, \dots, d-1$, is discussed in Remark 2.3.

We are most interested in the following example of A and n satisfying Condition 1.4.

Example 1.5 (Example of A and n defined piecewise satisfying Condition 1.4)

- D_{in} is as in §1.1 and such that $\Gamma \cap \{\mathbf{x} : x_d \geq 0\}$ is the graph of a C^0 function $f_+ : \mathbf{x}' \rightarrow \mathbb{R}$, and $\Gamma \cap \{\mathbf{x} : x_d \leq 0\}$ is the graph of a C^0 function $f_- : \mathbf{x}' \rightarrow \mathbb{R}$.
- A is as in Definition 1.1 and furthermore

$$A(\mathbf{x}) = \mathbf{1}_{D_{\text{in}}}(\mathbf{x}) \tilde{A}(\mathbf{x}) + \mathbf{1}_{D_{\text{out}}}(\mathbf{x}) I,$$

where $\mathbf{1}_D$ denotes the indicator function of a set D and $\tilde{A} \in L^\infty(D_{\text{in}}, \text{SPD})$ satisfies (1.8) (with A replaced by \tilde{A}), $(\tilde{A})_{d\ell}(\mathbf{x}) = 0$ for $\ell = 1, \dots, d-1$ and for all $\mathbf{x} \in D_{\text{in}}$, and $\tilde{A}_{\min} \geq 1$.

- n is as in Definition 1.1 and furthermore

$$n(\mathbf{x}) = \mathbf{1}_{D_{\text{in}}}(\mathbf{x}) \tilde{n}(\mathbf{x}) + \mathbf{1}_{D_{\text{out}}}(\mathbf{x}),$$

where $\tilde{n} \in L^\infty(D_{\text{in}}, \mathbb{R})$ satisfies (1.8) (with n replaced by \tilde{n}), and $\tilde{n}_{\max} \leq 1$.

In Example 1.5, if Γ is Lipschitz, then the first bullet point can be replaced by

$$x_d \mathbf{e}_d \cdot \mathbf{n}(\mathbf{x}) \geq 0 \quad \text{for all } \mathbf{x} \in \Gamma \text{ such that } \mathbf{n}(\mathbf{x}) \text{ is defined,} \quad (1.10)$$

and the boundary value problem is then transmission through a Lipschitz penetrable obstacle as in Lemma 1.2.

The following theorem bounds the norm of the solution operator of the Helmholtz transmission problem; i.e., the operator norm of the (linear) mapping $(H^1(B_R))' \ni F \rightarrow u \in H^1(B_R)$, given by

$$C_{\text{sol}}(\mathbf{A}, n, k, R, R_0) := \sup_{\substack{F \in (H_k^1(B_R))' \\ \|F\|_{(H_k^1(B_R))'} = 1}} \|u\|_{H_k^1(B_R)}, \quad (1.11)$$

where, for a bounded open set D ,

$$\|u\|_{H_k^1(D)}^2 := \int_D |\nabla u|^2 + k^2 |u|^2 \quad \text{and} \quad \|F\|_{(H_k^1(D))'} := \sup_{\substack{v \in H^1(D) \\ \|v\|_{H_k^1(D)} = 1}} |F(v)|. \quad (1.12)$$

The construction in [21, Lemma 3.10] (see also [81, Lemma 4.12]) giving lower bounds on C_{sol} with $\mathbf{A} = \mathbf{I}$ and $n = 1$ shows that C_{sol} must grow at least linearly with k as $k \rightarrow \infty$.

Theorem 1.6 (Well-posedness under Condition 1.4) *There exists $C_{\text{wave}}, C_1 > 0$ such that the following holds. Given $R > R_0 > 0$ and \mathbf{A} and n satisfying Condition 1.4, if $kR_0 \geq C_{\text{wave}}$ then the Helmholtz transmission problem of Definition 1.1 exists, is unique, and*

$$C_{\text{sol}}(\mathbf{A}, n, k, R, R_0) \leq \frac{1}{n_{\min}} \left(1 + 2(kR)^2(1 + kR_0)C_1 \right) =: C_{\text{layer}}(kR, kR_0, n_{\min}). \quad (1.13)$$

The key point is that, other than n_{\min} , all the terms on the right-hand side of (1.13) are independent of \mathbf{A} and n . Explicit expressions for C_{wave} and C_1 are available; see Remark 3.5 below. The notation C_{wave} is chosen because this constant determines the minimum number of wavelengths in B_{R_0} for the results of the theorem to hold.

Theorem 1.6 is obtained as a corollary of the following result.

Theorem 1.7 (A priori bound under Condition 1.4 for L^2 data) *Under the assumptions of Theorem 1.6, if $F(v) = \int_{B_R} f \bar{v}$ and $kR_0 \geq C_{\text{wave}}$, then*

$$\|u\|_{H_k^1(B_R)} \leq C_1(1 + kR_0)(kR)R \|f\|_{L^2(B_R)}. \quad (1.14)$$

Remark 1.8 (Plane-wave scattering) *A common Helmholtz problem in applications is scattering of an incident field u_{inc} (such as a plane wave or a point source), creating a scattered field u_{sca} , satisfying the Sommerfeld radiation condition, with the total field $u_{\text{inc}} + u_{\text{sca}}$ satisfying the Helmholtz equation with zero right-hand side (see, e.g., [59, Definition 2.4]). This problem fits into the framework of Definition 1.1 with $u = u_{\text{sca}} + \chi u_{\text{inc}}$, where χ is a smooth cutoff function such that $\chi = 1$ on D_{in} and $\chi = 0$ in a neighborhood of ∂B_R , and $f := (\Delta \chi)u_{\text{inc}} + 2\nabla u_{\text{inc}} \cdot \nabla \chi$.*

1.2.2 Discussion of the novelty of the well-posedness result in Theorem 1.6

The standard way to prove well-posedness of the variable-coefficient Helmholtz equation is to prove a unique continuation principle (UCP) and use Fredholm theory. In 2-d, a UCP for the Helmholtz equation holds with $\mathbf{A} \in L^\infty$ and $n \in L^p$ with $p > 1$ [2], therefore the well-posedness result of Theorem 1.6 for $d = 2$ is not new.

In contrast, the well-posedness result of Theorem 1.6 for $d = 3$ is new. Indeed, when $d = 3$ the UCP holds when \mathbf{A} is piecewise Lipschitz [5], [52, Proposition 2.11] (by using the UCP in the Lipschitz case [34, 47]) and $n \in L^{3/2}$ [45, 89]. However, an example of an $\mathbf{A} \in C^{0,\alpha}$ for all $\alpha < 1$ for which the solution of the transmission problem is not unique at a particular $k > 0$ (and thus the UCP fails) is given in [31, Theorem 1]. The only other Helmholtz well-posedness result we are aware of that is valid for \mathbf{A} with no smoothness assumptions other than being L^∞ is in [38]. There, well-posedness is proved for $\mathbf{A} \in L^\infty$ satisfying a radial-monotonicity condition (as opposed to the monotonicity in a single coordinate direction in (1.8)). The method of proof in [38] is similar to the present paper (see the discussion in §1.2.5 below).

1.2.3 Discussion of the novelty of the bound in Theorem 1.6

The bound (1.14) is novel in two ways.

(i) A standard way of obtaining frequency-explicit bounds on solutions of the high-frequency Helmholtz equation is to consider the billiard flow defined by the (semiclassical) principal symbol of the Helmholtz equation and use associated results on propagation of singularities under this flow [56], [57], [44, Chapter 24]. However, this flow is not well-defined for the class of A and n in Condition 1.4.

(ii) Even when the flow is defined, while there has been a large amount of work on proving bounds that are explicit in k , there are relatively few bounds in the literature that are explicit *both* in k and in the coefficients A and n (such as (1.13)/(1.14)).

Regarding (i): the flow is defined as the solution $(\mathbf{x}(t), \boldsymbol{\xi}(t))$ of the Hamiltonian system

$$\dot{x}_i(t) = \partial_{\xi_i} p(\mathbf{x}(t), \boldsymbol{\xi}(t)), \quad \dot{\xi}_i(t) = -\partial_{x_i} p(\mathbf{x}(t), \boldsymbol{\xi}(t)), \quad (1.15)$$

where the Hamiltonian equals the semiclassical principal symbol of the Helmholtz equation, namely

$$p(\mathbf{x}, \boldsymbol{\xi}) := \sum_{i=1}^d \sum_{j=1}^d A_{ij}(\mathbf{x}) \xi_i \xi_j - n(\mathbf{x});$$

see, e.g., [91, Page 281]. By the Picard–Lindelöf theorem, the flow exists and is unique if A, n are both $C^{1,1}$, since the coefficients of the ODE system (1.15) are then Lipschitz. By the well-known examples of ODE non-uniqueness with non-Lipschitz coefficients, if A and n are rougher than $C^{1,1}$, then the flow is not guaranteed to be well-defined. The flow can be defined piecewise, with results about the behaviour of singularities hitting the interface given in [55, Chapter 11], [58], and k -explicit bounds on the solution of the Helmholtz transmission problem when A and/or n are discontinuous on a C^∞ strictly-convex interface given in [17], [73], [72]. However, it is not possible to define the flow for the range of coefficients covered by Condition 1.4, which need only be L^∞ in the \mathbf{x}' directions.

Regarding (ii): the first such bounds were proved for the exterior Helmholtz equation in [8] (for A variable and $n = 1$) and [9], (for n variable and $A = 1$). Recent such bounds were proved in [59, 38, 32, 79] (and for problems posed on bounded domains with impedance boundary conditions [23, Chapter 2], [6, 11, 67, 78, 38, 39]), the renewed interest due to growing interest in the numerical analysis of Helmholtz equation with variable coefficients [24, 6, 11, 67, 30, 33, 25, 26, 70, 39, 32, 71, 50, 36, 51].

1.2.4 Discussion about the k -dependence in the bound (1.14)

The key points are the following.

- There exist (fixed) A and n such that C_{sol} grows super-algebraically in k as $k \rightarrow \infty$ due to trapped rays [74, 73, 14, 15]. The polynomial bound on C_{sol} in (1.13) shows that this behaviour is ruled out by Condition 1.4, which is consistent with the physical understanding of what causes rays to be trapped for the transmission problem.
- The recent results of [78] show that, in 1-d, C_{sol} can grow exponentially through a sequence n_j, k_j , with $k_j \rightarrow \infty$ as $j \rightarrow \infty$; these examples involve piecewise constant n (i.e. a 1-d layered medium), and the key point is that to get the exponential growth the width of the pieces need to be tied to k in a delicate way. This behaviour is ruled out for the layered obstacles included in Condition 1.4 via the polynomial bound on C_{sol} in (1.13), which is uniform in A and n satisfying Condition 1.4. Exponential growth of C_{sol} through a sequence n_j, k_j , with $k_j \rightarrow \infty$ as $j \rightarrow \infty$, in $d > 1$ is still possible through layered obstacles if the layers are radial – this is shown in [79], with radially symmetric n chosen based on the 1-d results of [78].

We now give more detail on these two points.

The case A and n fixed and $k \rightarrow \infty$. For the Helmholtz transmission problem of Definition 1.1, super-algebraic growth of C_{sol} through a sequence of k_j s has been proved in the following two cases.

- (i) A and n are as in Lemma 1.2 with D_{in} a C^∞ convex domain with strictly positive curvature, and the jumps of A and n have a certain combination of signs (e.g., moving outwards, A jumps down with n fixed, or n jumps up with A fixed) so that rays can be totally internally reflected when hitting Γ from inside D_{in} [73] (see also [14], [15], [1, Chapter 5] for similar results in the specific case when the obstacle is a ball). The solutions corresponding to the trapped rays are known as “whispering-gallery modes”; see, e.g., [3] and the references therein.
- (ii) $A = 1$ and n is C^∞ and spherically symmetric with $2n(r_1) + (\partial n / \partial r)(r_1) < 0$ for some r_1 [74] (see also [38, Theorem 7.7(ii)]¹; this condition on n causes great circles on $r = r_1$ to be stable trapped rays; see [74, Page 572]).

Neither of the situations in (i) or (ii) are allowed under Condition 1.4. Indeed, Condition 1.4 implies that $A_{\text{min}} \geq 1$ and $n_{\text{max}} \leq 1$ (as noted just below the condition), and these prevent A and n having the “bad” jumps in (i). Furthermore, the monotonicity condition on n (1.9) prevents n from satisfying the condition in (ii).

The case when A and n can depend on k and $k \rightarrow \infty$. For (1.2) posed on a 1-d interval with either Dirichlet or impedance boundary conditions at either end, and at least one of the ends having impedance boundary conditions, bounds on the Helmholtz solution where A and n have finite number of jumps are given in [24], [39]. These results have $C_{\text{sol}} \leq \exp(C(A, n))$ (see [39, Theorem 5.4 and 5.10]), but $C_{\text{sol}} \rightarrow \infty$ if the number of jumps goes to infinity. The fact that C_{sol} is independent of k is consistent with the fact that, for fixed A and n geometric-optic rays are not trapped, since although A and n can jump across interfaces, the 1-d nature of the problem means that no rays can get trapped moving tangent to the interface (like in Point (i) above).

The paper [78] considers the 1-d case with $A = 1$ and n variable and proves

- there exist sequences n_j, k_j (with $k_j \rightarrow \infty$ as $j \rightarrow \infty$) such that C_{sol} grows exponentially as $j \rightarrow \infty$ [78, Remark 14],
- if the number of jumps $\lesssim k$ then $C_{\text{sol}} \leq \exp(C(n)k)$, but $C(n)$ doesn’t blow up with number of jumps [78, Prop. 18], and
- for a class of n that oscillate between two values, with an arbitrarily-large number of jumps, $C_{\text{sol}} \leq \exp(C(n)k)$ and $C(n)$ doesn’t blow up with number of jumps [78, Theorem 22].

The paper [79] generates the results of [78] to radially-symmetric n in 3-d (see [79, Theorem 3.7] for the upper bounds and [79, Lemma 4.3] for the examples of exponential blow-up).

1.2.5 Summary of the ideas behind the proof of Theorem 1.6

Theorem 1.6 is proved by the following five steps.

- (i) Observing that Theorem 1.6 follows from Theorem 1.7 since $b(\cdot, \cdot)$ satisfies a Gårding inequality; see Lemma 2.9 below.
- (ii) Observing that, by Fredholm theory, to prove Theorem 1.7 it is sufficient to prove the bound (1.14) under the assumption of existence (see Lemma 2.8).
- (iii) Approximating the coefficients A and n in Condition 1.4 by a sequence of smooth coefficients $(A^\ell)_{\ell=0}^\infty$ and $(n^\ell)_{\ell=0}^\infty$ satisfying Condition 3.1 below (see §3.2); this condition is similar to Condition 1.4, but involves derivatives of the smooth coefficients A^ℓ and n^ℓ .
- (iv) Proving the bound (1.14) for these smooth coefficients, importantly with the constants C_{wave} and C_1 independent of ℓ , using a novel Morawetz-type identity ((2.2) below) involving a particular vector field and associated arguments introduced recently in [22] (see §3.1). The key point is that the vector field (defined by (3.4)) equals $\mathbf{e}_d x_d$ in a neighbourhood of $\text{supp}(1 - A)$ and

¹Strictly speaking, [74] proves the existence of a sequence of resonances exponentially close to the real axis, but then the “resonances to quasimodes” result of [84] implies super-algebraic growth through a sequence of real k_j s.

$\text{supp}(1 - n)$, where \mathbf{e}_d denotes the unit vector in the x_d direction; this vector field is constant in the \mathbf{x}' directions, and so “does not see” the behaviour of \mathbf{A} and n in these directions, hence why no constraint is imposed on this behaviour.

(v) Using approximation arguments from [38] to prove the bound (1.14) for the original \mathbf{A} and n (see Lemma 2.10); these approximation arguments were inspired by similar arguments in [86] in the setting of rough-surface scattering (with this thesis recently made available as [4]).

1.3 Main result II: homogenization

An attractive feature of Theorem 1.6 is that it does not constrain the variations of \mathbf{A} or n along the \mathbf{x}' hyperplane. In particular, highly-oscillatory coefficients are allowed, and the results in this section concern the limiting behaviour when the period of oscillations goes to zero. Theorem 1.6 would also allow one to do homogenization under assumptions other than periodicity (see, e.g., [27, Chapter 13]), but for simplicity we only consider a periodic setting here.

1.3.1 Statement of the result

With $\varepsilon > 0$ a (small) oscillation period, we define oscillatory coefficients n_ε and \mathbf{A}_ε created by repeating functions \hat{n} and $\hat{\mathbf{A}}$ on a grid of size ε inside a bounded Lipschitz domain D_{in} .

Definition 1.9 (Oscillatory coefficients in D_{in}) Let $Y := (0, 1)^d$ (i.e., the unit cube in \mathbb{R}^d). If $\hat{n} \in L^\infty(Y, \mathbb{R})$ and $\hat{\mathbf{A}} \in L^\infty(Y, \text{SPD})$, let

$$\hat{n}^\varepsilon(\mathbf{x}) := \hat{n}\left(\left\{\frac{\mathbf{x}}{\varepsilon}\right\}\right) \quad \text{and} \quad \hat{\mathbf{A}}^\varepsilon(\mathbf{x}) := \hat{\mathbf{A}}\left(\left\{\frac{\mathbf{x}}{\varepsilon}\right\}\right)$$

for all $\mathbf{x} \in \mathbb{R}^d$, where $\{\mathbf{x}/\varepsilon\}_j = (x_j/\varepsilon) \bmod 1$. Then, given a bounded Lipschitz domain D_{in} satisfying (1.10), let

$$n_\varepsilon := \mathbf{1}_{D_{\text{in}}}\hat{n}^\varepsilon + \mathbf{1}_{D_{\text{out}}} \quad \text{and} \quad \mathbf{A}_\varepsilon := \mathbf{1}_{D_{\text{in}}}\hat{\mathbf{A}}^\varepsilon + \mathbf{1}_{D_{\text{out}}}\mathbf{I}. \quad (1.16)$$

We now impose constraints on \hat{n} and $\hat{\mathbf{A}}$ so that n_ε and \mathbf{A}_ε satisfy Condition 1.4 (and so Theorem 1.6 applies) – these are the first three points in Condition 1.10 below. We also impose additional constraints on \hat{n} and $\hat{\mathbf{A}}$ so that the correctors in the homogenization argument (see §4 below) have sufficient regularity – these constraints are in the final point in Condition 1.10.

Condition 1.10 (Admissible periodic patterns) $\hat{n} \in L^\infty(Y)$ and $\hat{\mathbf{A}} \in L^\infty(Y, \text{SPD})$ are admissible periodic patterns if

- \hat{n} and $\hat{\mathbf{A}}$ are independent of y_d
- $\hat{A}_{d\ell} = 0$ for $\ell = 1, \dots, d - 1$,
- $\hat{\mathbf{A}}_{\text{min}} \geq 1$ and $\hat{n}_{\text{max}} \leq 1$,
- either
 - (a) \hat{n} and $\hat{\mathbf{A}}$ only depend on y_1 (or, when $d = 3$, only on y_2) and $\hat{\mathbf{A}}$ is piecewise $C^{0,1}$.
 - (b) the periodic extension of $\hat{\mathbf{A}}$ is piecewise $C^{1,1}$ and that of \hat{n} is piecewise H^1 on a partition of \mathbb{R}^d that consists of subdomains with $C^{2,1}$ boundaries.

The class of coefficients covered by Condition 1.10 corresponds to obstacles made of thin layers in 2D, and of thin layers or fibers in 3D.

Remark 1.11 (Physical relevance of finely-layered and finely-fibred materials) Many key applications motivating homogenized theory are based on “composite” or “meta” materials. Such materials are based on blending two (or more) materials in a periodic manner at a fine scale, and thus are modelled by piecewise-constant periodic patterns, as covered by Condition 1.10. Particular instances of layered and fibred media arise when considering the propagation of elastic waves through rocks [16] and electromagnetic waves in thin-film coatings [18] or optical fibres [88].

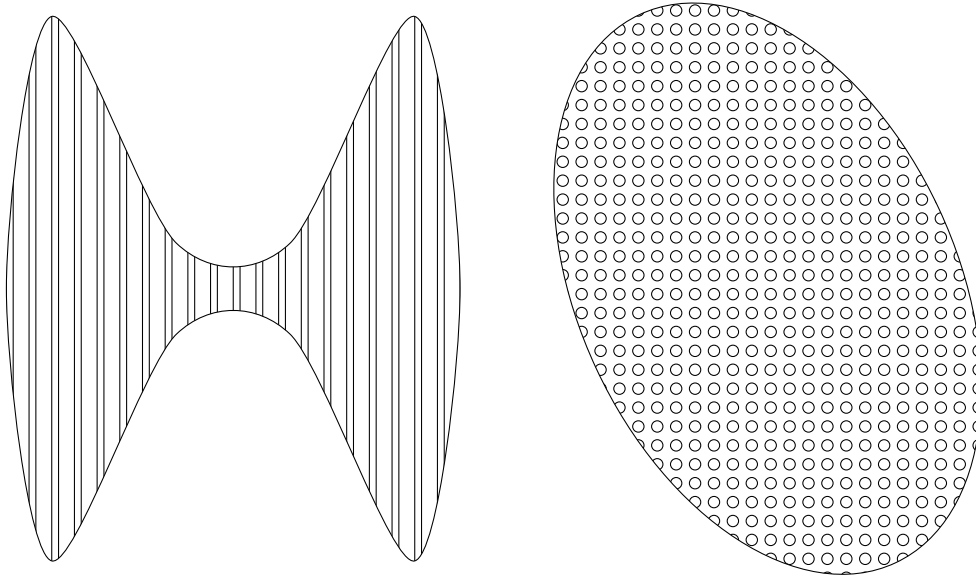

Figure 1.2: Sketches of admissible periodic patterns, with the black lines representing discontinuities in the coefficients. Left-panel: if the coefficients in this 2-d domain are constant in the vertical direction, then they satisfy (a) in Condition 1.10. Right-panel: horizontal cross section of a 3-d domain satisfying (b) in Condition 1.10.

Corollary 1.12 *Let C_{wave} be as in Theorem 1.6. If \hat{n} and $\hat{\mathbf{A}}$ satisfy Condition 1.10 and $kR_0 \geq C_{\text{wave}}$, then, for all $\varepsilon > 0$, the solution of the variational problem (1.5) with coefficients n_ε and \mathbf{A}_ε exists and is unique, and, with C_{layer} defined by (1.13),*

$$C_{\text{sol}}(\mathbf{A}_\varepsilon, n_\varepsilon, k, R, R_0) \leq C_{\text{layer}}(kR, kR_0, \hat{n}_{\min}). \quad (1.17)$$

Crucially, the bound (1.17) is uniform in ε , and this uniformity allows us to extract a convergent subsequence u_ε . In fact, by classical homogenization theory [7, 27], in the limit $\varepsilon \rightarrow 0$, the whole sequence u_ε to u_0 weakly in $H^1(B_R)$ and strongly in $L^2(B_R)$, where u_0 is the solution to the transmission problem of Definition 1.1 with constant “homogenized” coefficients \mathbf{A}^H and n^H . These homogenized coefficients are obtained from $\hat{\mathbf{A}}$ and \hat{n} by averaging formulas given by (4.7) and (4.2) below; note that these are the same formulas for the coercive case (see, e.g., [7, Chapter 1], [27, Chapter 6]).

Recall that a domain $D \subset \mathbb{R}^d$ is *star-shaped with respect to the point* $\mathbf{x}_0 \in \mathbb{R}^d$ if, whenever $\mathbf{x} \in D$, the line segment $[\mathbf{x}_0, \mathbf{x}] \in D$.

Lemma 1.13 (Well-posedness of the homogenized problem) *Let C_{wave} be as in Theorem 1.7. Given \hat{n} and $\hat{\mathbf{A}}$ satisfying Condition 1.10, let n^H and \mathbf{A}^H be defined by (4.2) and (4.7), respectively, and let $u_0 \in H^1(B_R)$ be the solution of the variational problem (1.5) with coefficients n^H and \mathbf{A}^H (we then say that u_0 is the solution of the homogenized problem).*

Then, if $kR_0 \geq C_{\text{wave}}$, u_0 exists and is unique, and

$$C_{\text{sol}}(\mathbf{A}^H, n^H, k, R, R_0) \leq C_{\text{layer}}(kR, kR_0, \hat{n}_{\min}). \quad (1.18)$$

Furthermore, if D_{in} is additionally star-shaped with respect to a point, then, for all $k > 0$, u_0 exists and is unique, and

$$C_{\text{sol}}(\mathbf{A}^H, n^H, k, R, R_0) \leq \frac{1}{\hat{n}_{\min}} \left(1 + kR \frac{4}{\sqrt{\hat{n}_{\min}}} \sqrt{1 + \frac{1}{\hat{n}_{\min}} \left(1 + \frac{d-1}{2kR} \right)^2} \right). \quad (1.19)$$

Theorem 1.14 (k - and ε -explicit homogenization error estimate in $H_k^1(B_R)$) Let C_{wave} and C_{layer} be as in Theorem 1.6. Let \hat{n} and \hat{A} satisfy Condition 1.10 and assume that Γ is $C^{1,1}$. Given $f \in L^2(B_R)$, let u_ε be the solution of the variational problem (1.5) with coefficients A_ε and n_ε and $F(v) := \int_{B_R} f \bar{v}$. Let u_0 be the solution of the variational problem (1.5) with this F and coefficients A^H and n^H , and let u_1^ε be defined in terms of u_0 by (4.9) and (4.1) below.

If $kR_0 \geq C_{\text{wave}}$ then u_ε , u_0 , and u_1^ε exist and are unique, and there exist $C_2, C_3 > 0$ (depending only on \hat{A}, \hat{n} , and D_{in}) such that

$$k \|u_\varepsilon - u_0 - \varepsilon u_1^\varepsilon\|_{H_k^1(D_{\text{in}})} + k \|u_\varepsilon - u_0\|_{H_k^1(D_{\text{out}})} \leq C_2 C_{\text{layer}}(kR, kR_0, \hat{n}_{\text{min}}) \left((k\varepsilon)^{1/2} + k\varepsilon \right) \left(\|u_0\|_{H^2(B_R)} + k \|u_0\|_{H_k^1(B_R)} \right) \quad (1.20)$$

$$\leq C_3 C_{\text{layer}}(kR, kR_0, \hat{n}_{\text{min}}) \left((k\varepsilon)^{1/2} + k\varepsilon \right) C_{\text{sol}}(A^H, n^H, k, R, R_0) \|f\|_{L^2(B_R)}. \quad (1.21)$$

Since

$$\|u_\varepsilon\|_{H_k^1(B_R)} \leq \|u_\varepsilon - u_0\|_{H_k^1(B_R)} + \|u_0\|_{H_k^1(B_R)},$$

the bound on $u_\varepsilon - u_0$ from Theorem 1.14 and the definition of $C_{\text{sol},H}$ then imply the following bound on $C_{\text{sol}}(A_\varepsilon, n_\varepsilon, k, R, R_0)$.

Corollary 1.15 (Improved bound on $C_{\text{sol},\varepsilon}$ for $k\varepsilon$ sufficiently small (depending on k))

Let C_{wave} and C_{layer} be as in Theorem 1.6. Let \hat{n} and \hat{A} satisfy Condition 1.10 and assume that Γ is $C^{1,1}$. Then there exists C_5 (depending only on \hat{A}, \hat{n} , and D_{in}) such that if $kR_0 \geq C_{\text{wave}}$ then

$$C_{\text{sol}}(A_\varepsilon, n_\varepsilon, k, R, R_0) \leq \frac{C_5}{\hat{n}_{\text{min}}} \left[1 + \left((k\varepsilon)^{1/2} + k\varepsilon \right) C_{\text{layer}}(kR, kR_0, \hat{n}_{\text{min}}) \right] C_{\text{sol}}(A^H, n^H, k, R, R_0). \quad (1.22)$$

Corollary 1.15 shows that if $k\varepsilon$ is sufficiently small (depending on k), then the problem with coefficients A_ε and n_ε inherits the behaviour of the solution operator for the homogenized problem.

1.3.2 Discussion of the novelty and context of Theorem 1.14.

The first thing to highlight about Theorem 1.14 is that it is a k -explicit analogue of the H^1 error bound in [13, Theorem 2]. More precisely, [13, Theorem 2] proves the bound

$$\|u_\varepsilon - u_0 - \varepsilon u_1^\varepsilon\|_{H_k^1(D_{\text{in}})} + \|u_\varepsilon - u_0\|_{H_k^1(D_{\text{out}})} \leq C(k) \varepsilon^{1/2} \|u_0\|_{H^2(B_R)},$$

for some unspecified $C(k)$, with this bound valid for sufficiently small kR and then arbitrarily small ε/R . In contrast, in Theorem 1.14, kR can be arbitrarily large, and ε/R can be tied to kR . We recall that (i) a main novelty of [13, Theorem 2] is that it uses boundary correctors for homogenization of a transmission problem (as opposed to using boundary correctors for problems on bounded domains with Dirichlet or Neumann boundary conditions; see, e.g., [7, 64, 65, 40, 90, 41, 68, 46, 48, 85, 49, 80]), and (ii) [13, Theorem 2] also proves the L^2 error estimate $\|u_\varepsilon - u_0\|_{L^2(B_R)} \leq C(k) \varepsilon \|u_0\|_{H^2(B_R)}$, but for brevity we have not pursued here obtaining a k -explicit analogue of this result.

The main obstacle for obtaining homogenization results about the Helmholtz equation for large kR is that the first step of the homogenization procedure relies on a uniform-in- ε bound on the H^1 norm of u_ε , which allows one to extract a weakly-converging subsequence. Such estimate is immediate for the coercive PDE $-\nabla \cdot (A_\varepsilon u) = f$, since the coercivity constant only depends on A_{min} , which is independent of ε . In Appendix C, we recall how the $b(\cdot, \cdot)$ defined by (1.6) is coercive if kR is sufficiently small, with both the coercivity constant (and hence C_{sol}) and the constant for “sufficiently small” independent of ε and depending on A_{min} and n_{max} ; see Lemma C.1 below. Therefore, homogenization results for the Helmholtz equation can be obtained for kR sufficiently small, and this is implicitly what [13] do.² In contrast, if kR is sufficiently large, then $b(\cdot, \cdot)$ is

²The paper [13] cites [12, Theorem 5.26] as a reference for C_{sol} being independent of ε and depending on A_ε and n_ε only through $A_{\text{max}}, A_{\text{min}}, n_{\text{max}}$, and n_{min} (see [13, Bottom of Page 2539 and top of Page 2540]). Actually, [12, Theorem 5.26] records how Fredholm theory proves an a priori bound on the solution of the transmission problem; however this theory (relying on abstract functional analysis arguments) is unable to give the constant in this bound. The arguments in [13] hold, however, with the results of Appendix C replacing reference to [12, Theorem 5.26], and under the explicit assumption that kR is sufficiently small.

not coercive (see, e.g., [82, §6.1.6]); furthermore, at least when A_ε and n_ε are smooth, [32] shows that C_{sol} depends on global properties of A_ε and n_ε (more precisely, C_{sol} is proportional to the length of the longest ray in B_R). Therefore, obtaining a uniform-in- ε bound on C_{sol} for arbitrary A_ε and n_ε and arbitrary kR is very challenging. The present paper bypasses this fundamental problem by considering the restricted class of A_ε and n_ε of Condition 1.10, for which Theorem 1.6 gives the required bound that is uniform in ε and valid for large kR . Another place where this problem is bypassed is [10]: this paper considers homogenization of particular 2-d Helmholtz transmission problem (where the contrast in the coefficients depends on ε). The result of [10] is that, via a contradiction argument, the sequence u_ε is bounded in L^2 and two-scale converges to the homogenized solution (albeit without an error estimate); this result is valid for fixed k , excluding a countable set, but crucially not assumed to be small.

Finally, we note that another difference between the analysis in the present paper and that of [13] is that, for simplicity, [13] assume that \hat{A} , \hat{n} , and D_{in} are C^∞ , but the present paper makes much weaker regularity assumptions on \hat{A} , \hat{n} , and D_{in} . In particular, we allow for piecewise smooth \hat{A} and \hat{n} ; recall from Remark 1.11 that these are particularly important in applications.

1.3.3 Discussion of the k - and ε -dependence of the bounds in Theorem 1.14 and Corollary 1.15

The bound (1.20) shows that the “relative error”

$$\frac{k\|u_\varepsilon - u_0 - \varepsilon u_1^\varepsilon\|_{H_k^1(D_{\text{in}})} + k\|u_\varepsilon - u_0\|_{H_k^1(D_{\text{out}})}}{\|u_0\|_{H^2(B_R)} + k\|u_0\|_{H_k^1(B_R)}} \quad (1.23)$$

is controllably small if $C_{\text{layer}}(kR, kR_0, \hat{n}_{\text{min}})(k\varepsilon)^{1/2}$ is small, independently of k and ε , i.e., if $k\varepsilon \leq c(kR)^{-6}$ (with c independent of k and ε) by the definition of $C_{\text{layer}}(kR, kR_0, n_{\text{min}})$ (1.13). While this is certainly pessimistic, to our knowledge it is the first homogenization result for the Helmholtz equation that is explicit in both ε and k . Note that $C_{\text{layer}}(kR, kR_0, n_{\text{min}}) \gtrsim kR$ (see the discussion after (1.12)), and therefore even if we obtained a sharper upper bound on $C_{\text{layer}}(kR, kR_0, n_{\text{min}})$, the bound (1.20) would still only show that (1.23) is small when $k\varepsilon \leq c(kR)^{-1}$. (Note that the factor of $C_{\text{layer}}(kR, kR_0, n_{\text{min}})$ in the bound on (1.23) from (1.20) arises from the standard treatment of $u_\varepsilon - u_0$ minus the correctors as a solution of the PDE – in our case the Helmholtz equation; see (4.27) and (4.28) below.)

The bound (1.22) shows that if $C_{\text{layer}}(kR, kR_0, \hat{n}_{\text{min}})(k\varepsilon)^{1/2}$ is bounded independently of k and ε , then

$$C_{\text{sol}}(A_\varepsilon, n_\varepsilon, k, R, R_0) \lesssim C_{\text{sol}}(A^H, n^H, k, R, R_0). \quad (1.24)$$

From (1.17) and (1.18), both $C_{\text{sol}}(A_\varepsilon, n_\varepsilon, k, R, R_0)$ and $C_{\text{sol}}(A^H, n^H, k, R, R_0)$ are $\leq C_{\text{layer}}(kR, kR_0, n_{\text{min}})$. Therefore, the bound (1.24) is only interesting when $C_{\text{sol}}(A^H, n^H, k, R, R_0) \ll C_{\text{layer}}(kR, kR_0, n_{\text{min}})$. A concrete case when this is true is when D_{in} is star-shaped with respect to a point, since then $C_{\text{sol}}(A^H, n^H, k, R, R_0) \lesssim kR$ by (1.19) (which is the smallest possible growth of C_{sol} with kR), whereas $C_{\text{layer}}(kR, kR_0, n_{\text{min}}) \lesssim (kR)^3$ by its definition (1.13).

2 Preliminary results

2.1 Morawetz-type identities and associated results

When writing these identities, it is convenient to use the notation that $\langle \mathbf{a}, \mathbf{b} \rangle := \sum_{j=1}^d a_j \bar{b}_j$ for $\mathbf{a}, \mathbf{b} \in \mathbb{C}^d$. Here and in the rest of the paper, we use the convention that all indices are lowered, and repeated indices i, j , and ℓ , are summed over, but *not* repeated indices d .

Lemma 2.1 (Morawetz-type identity) *Let $D \subset \mathbb{R}^d$. Let $v \in C^2(D)$, $A \in C^1(D, \text{Sym})$, $n \in C^1(D, \mathbb{R})$, $\mathbf{Z} \in C^1(D, \mathbb{R}^d)$, $\alpha \in C^2(D, \mathbb{R})$, and $\beta \in C^1(D, \mathbb{R})$. Let*

$$\mathcal{L}_{A,n}v := \nabla \cdot (A\nabla v) + k^2 n v \quad \text{and} \quad \mathcal{Z}v := \mathbf{Z} \cdot \nabla v - ik\beta v + \alpha v. \quad (2.1)$$

Then, in D ,

$$\begin{aligned} 2\Re\{\overline{\mathcal{Z}v} \mathcal{L}_{A,n}v\} &= \nabla \cdot \left[2\Re\{\overline{\mathcal{Z}v} A \nabla v\} + \mathbf{Z} \left(k^2 n |v|^2 - \langle A \nabla v, \nabla v \rangle \right) - \nabla \alpha |v|^2 \right] - (2\alpha - \nabla \cdot \mathbf{Z}) \langle A \nabla v, \nabla v \rangle \\ &\quad + \left\langle ((\mathbf{Z} \cdot \nabla) A) \nabla v, \nabla v \right\rangle - \left((\nabla \cdot \mathbf{Z} - 2\alpha) n + \mathbf{Z} \cdot \nabla n \right) k^2 |v|^2 - 2\Re\langle A \nabla v, \partial \mathbf{Z} \nabla v \rangle \\ &\quad - 2\Re\{ik\bar{v} \langle A \nabla v, \nabla \beta \rangle\} - 2\Re\{\bar{v} \langle (A - I) \nabla v, \nabla \alpha \rangle\} + \Delta \alpha |v|^2, \end{aligned} \quad (2.2)$$

where $\partial \mathbf{Z}$ is the derivative matrix of \mathbf{Z} , i.e. $(\partial \mathbf{Z})_{ij} = \partial_i Z_j$.

Proof. Splitting $\mathcal{Z}v$ up into its component parts, we see that the identity (2.2) is the sum of the following four identities:

$$\begin{aligned} 2\Re\{\mathbf{Z} \cdot \overline{\nabla v} \mathcal{L}_{A,n}v\} &= \nabla \cdot \left[2\Re\{\mathbf{Z} \cdot \overline{\nabla v} A \nabla v\} + \mathbf{Z} \left(k^2 n |v|^2 - \langle A \nabla v, \nabla v \rangle \right) \right] + \nabla \cdot \mathbf{Z} \langle A \nabla v, \nabla v \rangle \\ &\quad - 2\Re\langle A \nabla v, \partial \mathbf{Z} \nabla v \rangle + \left\langle ((\mathbf{Z} \cdot \nabla) A) \nabla v, \nabla v \right\rangle - (\nabla \cdot \mathbf{Z} n + \mathbf{Z} \cdot \nabla n) k^2 |v|^2, \end{aligned} \quad (2.3)$$

$$2\Re\{ik\beta \bar{v} \mathcal{L}_{A,n}v\} = \nabla \cdot [2\Re\{ik\beta \bar{v} A \nabla v\}] - 2\Re\{ik\bar{v} \langle A \nabla v, \nabla \beta \rangle\}, \quad (2.4)$$

$$2\Re\{\alpha \bar{v} \mathcal{L}_{A,n}v\} = \nabla \cdot [2\Re\{\alpha \bar{v} A \nabla v\}] + 2\alpha k^2 n |v|^2 - 2\alpha \langle A \nabla v, \nabla v \rangle - 2\Re\{\bar{v} \langle A \nabla v, \nabla \alpha \rangle\}. \quad (2.5)$$

and

$$0 = -\nabla \cdot [\nabla \alpha |v|^2] + 2\Re\{\bar{v} \nabla \alpha \cdot \nabla v\} + \Delta \alpha |v|^2. \quad (2.6)$$

To prove (2.4), (2.5), and (2.6), expand the divergences on the right-hand sides (remembering that α and β are real and that A is symmetric, so $\langle A \boldsymbol{\xi}, \boldsymbol{\xi} \rangle$ is real for any $\boldsymbol{\xi} \in \mathbb{C}^d$).

The basic ingredient of (2.3) is the identity

$$(\overline{\mathbf{Z} \cdot \nabla v}) \nabla \cdot (A \nabla v) = \nabla \cdot [(\mathbf{Z} \cdot \overline{\nabla v}) A \nabla v] - \langle A \nabla v, \partial \mathbf{Z} \nabla v \rangle - ((\mathbf{Z} \cdot \nabla) \overline{\nabla v}) \cdot A \nabla v. \quad (2.7)$$

To prove this, expand the divergence on the right-hand side and use the fact that the second derivatives of v commute. We would like each term on the right-hand side of (2.7) to either be single-signed or be the divergence of something. To deal with the final term we use the identity

$$2\Re\{(\mathbf{Z} \cdot \nabla) \overline{\nabla v} \cdot A \nabla v\} = \nabla \cdot [\mathbf{Z} \langle A \nabla v, \nabla v \rangle] - (\nabla \cdot \mathbf{Z}) \langle A \nabla v, \nabla v \rangle - \left\langle ((\mathbf{Z} \cdot \nabla) A) \nabla v, \nabla v \right\rangle, \quad (2.8)$$

which can be proved by expanding the divergence on the right-hand side and using the fact that A is symmetric. Therefore, taking twice the real part of (2.7) and using (2.8) yields

$$\begin{aligned} 2\Re\{(\mathbf{Z} \cdot \nabla v) \nabla \cdot (A \nabla v)\} &= \nabla \cdot \left[2\Re\{(\mathbf{Z} \cdot \overline{\nabla v}) A \nabla v\} - \mathbf{Z} \langle A \nabla v, \nabla v \rangle \right] + (\nabla \cdot \mathbf{Z}) \langle A \nabla v, \nabla v \rangle \\ &\quad + \left\langle ((\mathbf{Z} \cdot \nabla) A) \nabla v, \nabla v \right\rangle - 2\Re\langle A \nabla v, \partial \mathbf{Z} \nabla v \rangle. \end{aligned} \quad (2.9)$$

Now add k^2 times

$$2\Re\{(\mathbf{Z} \cdot \overline{\nabla v}) n v\} = \nabla \cdot [\mathbf{Z} n |v|^2] - (\nabla \cdot \mathbf{Z}) n |v|^2 - \mathbf{Z} \cdot \nabla n |v|^2$$

(which is the analogue of (2.8) with the vector ∇v replaced by the scalar v and the matrix A replaced by the scalar n) to (2.9) to obtain (2.3). \blacksquare

Remark 2.2 (Bibliographic remarks on Morawetz-type identities for $\mathcal{L}_{A,n}$) *Multiplying Δv by a derivative of v goes back to Rellich [75, 76], and multiplying $\nabla \cdot (A \nabla v)$ by a derivative of v goes back to Hörmander [43] and Payne and Weinberger [69] (e.g., the identity (2.2) with $\mathbf{Z} = \mathbf{x}$ and n, α , and β all equal zero appears as [69, Equation 2.4]).*

In the context of the Helmholtz equation, the identity (2.2) with $A = I$, $n = 1$, \mathbf{x} replaced by a general vector field, and α and β replaced by general scalar fields was the heart of Morawetz's paper [62] (following the earlier work [61, 63]); hence why we call (2.2) a "Morawetz-type" identity. The identity (2.2) with $\mathbf{Z} = \mathbf{x}$, A variable, and $n = 1$ was used by Bloom in [8], and the identity (2.2) with $\mathbf{Z} = \mathbf{x}$, $A = I$, and variable n was used in Bloom and Kazarinoff in [9]. To our knowledge, the present paper is the first time that the identity (2.2), with A, n, \mathbf{Z}, β , and α all variable, has appeared in the literature.

Remark 2.3 (The origin of the condition $(A)_{d\ell} = 0$ for $\ell = 1, \dots, d-1$ in Condition 1.4)
Our argument below requires that the term $2\Re\langle A\nabla v, \partial\mathbf{Z}\nabla v \rangle$ be bounded below by a multiple of $|\partial_d v|^2$ when $\mathbf{Z} = \mathbf{e}_d x_d$. Under this choice of \mathbf{Z} ,

$$2\Re\langle A\nabla v, \partial\mathbf{Z}\nabla v \rangle = 2\Re\left\{\overline{\partial_d v}\left(\sum_{\ell=1}^d (A_{d\ell})\partial_\ell v\right)\right\}, \quad (2.10)$$

hence we impose that $(A)_{d\ell} = 0$ for $\ell = 1, \dots, d-1$.

For notational convenience, given $\mathbf{A}, n, \mathbf{Z}, \beta$, and α , we let

$$\mathbf{Q}(v) := 2\Re(\overline{\mathbf{Z}v} A\nabla v) + \mathbf{Z}(k^2 n|v|^2 - \langle A\nabla v, \nabla v \rangle) - \nabla\alpha|v|^2, \quad (2.11)$$

and

$$\begin{aligned} P(v) := & 2\Re(\overline{\mathbf{Z}v} \mathcal{L}_{\mathbf{A},n} v) + (2\alpha - \nabla \cdot \mathbf{Z})\langle A\nabla v, \nabla v \rangle \\ & - \left\langle ((\mathbf{Z} \cdot \nabla)A)\nabla v, \nabla v \right\rangle + \left((\nabla \cdot \mathbf{Z} - 2\alpha)n + \mathbf{Z} \cdot \nabla n \right) k^2 |v|^2 + 2\Re\langle A\nabla v, \partial\mathbf{Z}\nabla v \rangle \\ & + 2\Re(ik\bar{v}\langle A\nabla v, \nabla\beta \rangle) + 2\Re(\bar{v}\langle (A - I)\nabla v, \nabla\alpha \rangle) - \Delta\alpha|v|^2, \end{aligned} \quad (2.12)$$

so that the identity (2.2) becomes

$$\nabla \cdot \mathbf{Q}(v) = P(v).$$

Lemma 2.4 (The Morawetz-type identity (2.2) integrated over a ball) *Recall the notation that $B_R := \{\mathbf{x} : |\mathbf{x}| < R\}$ and $\Gamma_R := \partial B_R$. On Γ_R , let ∂_r denote the normal derivative and let ∇_S denote the surface gradient. Let $v \in H^2(B_R)$, $\mathbf{A} \in C^1(\overline{B_R}, \text{SPD})$, $n \in C^1(\overline{B_R}, \mathbb{R})$, $\mathbf{Z} \in C^1(\overline{B_R}, \mathbb{R}^d)$, $\beta \in C^1(\overline{B_R}, \mathbb{R})$, and $\alpha \in C^2(\overline{B_R}, \mathbb{R})$. Suppose further that, in a neighbourhood of Γ_R , $\mathbf{A} = I$, $n = 1$, $\mathbf{Z} = \mathbf{x}$, and α is constant. Then*

$$\int_{B_R} P(v) = \int_{\Gamma_R} R \left(|\partial_r v|^2 - |\nabla_S u|^2 + k^2 |u|^2 \right) - 2k \Im \int_{\Gamma_R} \beta \bar{v} \partial_r v + 2\alpha \Re \int_{\Gamma_R} \bar{v} \partial_r v \quad (2.13)$$

where $P(v)$ is defined by (2.12).

Proof. We first assume that $v \in C^\infty(\overline{B_R})$. Given a Lipschitz domain D with outward-pointing unit normal vector $\boldsymbol{\nu}$, recall that the divergence theorem $\int_D \nabla \cdot \mathbf{F} = \int_{\partial D} \mathbf{F} \cdot \boldsymbol{\nu}$ is valid when $\mathbf{F} \in C^1(\overline{D}, \mathbb{C}^d)$ [53, Theorem 3.34], and thus for $\mathbf{F} \in H^1(D, \mathbb{C}^d)$ by the density of $C^1(\overline{D})$ in $H^1(D)$ [53, Theorem 3.29] and the continuity of trace operator from $H^1(D)$ to $H^{1/2}(\partial D)$ [53, Page 77]. Recall that the product of a $H^1(D)$ function and a $C^1(\overline{D})$ function is in $H^1(D)$, and the usual product rule for differentiation holds for such functions. This result implies that \mathbf{Q} defined by (2.11) is in $H^1(D, \mathbb{C}^d)$ and then (2.2) implies that $\int_{B_R} \nabla \cdot \mathbf{Q} = \int_{B_R} P$. We now need to show that $\mathbf{Q} \cdot \widehat{\mathbf{x}}$ equals the integrand on the right-hand side of (2.13).

The assumptions that $\mathbf{A} = I$, $n = 1$, $\mathbf{Z} = \mathbf{x}$, and α is constant in a neighbourhood of Γ_R imply that, in this neighbourhood,

$$\mathbf{Q}(v) := 2\Re((\mathbf{x} \cdot \nabla v + ik\beta\bar{v} + \alpha\bar{v})\nabla v) + \mathbf{x}(k^2|v|^2 - |\nabla v|^2). \quad (2.14)$$

Since $v \in C^\infty(\overline{B_R})$, $\nabla v = \widehat{\mathbf{x}}\partial_r v + \nabla_S v$ on Γ_R . Using this, along with the fact that $\widehat{\mathbf{x}} \cdot \nabla_S v = 0$, in (2.14), we find that $\mathbf{Q} \cdot \widehat{\mathbf{x}}$ equals the integrand on the right-hand side of (2.13).

We have therefore proved the result under the additional condition that $v \in C^\infty(\overline{B_R})$. The result for $v \in H^2(B_R)$ then follows from (i) the density of $C^\infty(\overline{B_R})$ in $H^2(B_R)$ [53, Page 77] and (ii) the fact that (2.13) is continuous in v with respect to the topology of $H^2(B_R)$. (Regarding (ii), recall that, since $\Gamma_R \in C^{1,1}$, both ∂_r and ∇_S map $H^2(B_R) \rightarrow L^2(\Gamma_R)$ by properties of the trace map [53, Theorem 3.37].) \blacksquare

The following lemma deals with the contribution from Γ_R in (2.13) when v equals a solution of the Helmholtz equation satisfying the Sommerfeld radiation condition.

Lemma 2.5 (Inequality on Γ_R for outgoing Helmholtz solutions) *Let u be a solution of the homogeneous Helmholtz equation in $\mathbb{R}^d \setminus \overline{B_{R_0}}$, for some $R_0 > 0$, satisfying the Sommerfeld radiation condition (1.1). Let $\alpha \in \mathbb{R}$ with $2\alpha \geq d - 1$. Then, for $R > R_0$,*

$$\int_{\Gamma_R} R \left(|\partial_r u|^2 - |\nabla_S u|^2 + k^2 |u|^2 \right) - 2kR \Im \int_{\Gamma_R} \bar{u} \partial_r u + 2\alpha \Re \int_{\Gamma_R} \bar{u} \partial_r u \leq 0, \quad (2.15)$$

where ∇_S is the surface gradient on $r = R$.

References for proof of Lemma 2.5. See [21, Lemma 2.1] or [83, Lemma 2.4] for the proof when $d = 2, 3$ and [59, Lemma 4.4] for general $d \geq 2$. \blacksquare

The idea behind the proof of Lemma 2.5 is that, when $2\alpha = d - 1$, the result follows integrating over $\mathbb{R}^d \setminus \overline{B_R}$ the following identity, which first appeared as [63, Equation 1.2],

$$\begin{aligned} 2\Re\{\overline{\mathcal{M}_\alpha v} \mathcal{L}v\} &= \nabla \cdot \left[2\Re\{\overline{\mathcal{M}_\alpha v} \nabla v\} + (k^2 |v|^2 - |\nabla v|^2) \mathbf{x} \right] \\ &\quad + (2\alpha - (d - 1))(k^2 |v|^2 - |\nabla v|^2) - \left(|\nabla v|^2 - \left| \frac{\partial v}{\partial r} \right| \right) - \left| \frac{\partial v}{\partial r} - ikv \right|^2. \end{aligned} \quad (2.16)$$

where

$$\mathcal{M}_\alpha v := r \left(\frac{\partial v}{\partial r} - ikv + \frac{\alpha}{r} v \right), \quad (2.17)$$

$\alpha \in \mathbb{R}$, and $\partial v / \partial r = \mathbf{x} \cdot \nabla v / r$. In particular, with (2.16) written as $\nabla \cdot \mathbf{Q}(v) = P(v)$, the term on the left-hand side of (2.15) is $\int_{\Gamma_R} \mathbf{Q}(u)$; this is why the constant in (2.15) is denoted by α , to emphasise its connection with the function α in (2.1)/(2.17). Lemma 2.5 therefore implies that if the multiplier \mathcal{Z} (2.1) in the integrated identity (2.13) is equal to \mathcal{M}_α (with $2\alpha \geq d - 1$) outside a large ball, then the right-hand side of (2.13) is ≤ 0 .

2.2 Background results for the Helmholtz transmission problem

Lemma 2.6 (Two key properties of DtN_k)

(i)
$$\Re\{-\langle \text{DtN}_k \phi, \phi \rangle_{\Gamma_R}\} \geq 0 \quad \text{for all } \phi \in H^{1/2}(\Gamma_R), \quad (2.18)$$

where $\langle \cdot, \cdot \rangle_{\Gamma_R}$ denotes the duality pairing on Γ_R .

(ii) There exists $C_{\text{DtN}} > 0$, independent of k , such that

$$\left| \langle \text{DtN}_k u, v \rangle_{\Gamma_R} \right| \leq C_{\text{DtN}} \|u\|_{H_k^1(D_R)} \|v\|_{H_k^1(D_R)} \quad \text{for all } u, v \in H^1(D_R). \quad (2.19)$$

References for the proof. (i) is proved in [66, Theorem 2.6.4, p.97], [54, Lemma 3.3], or [21, Lemma 2.1], and (ii) is proved in [54, Lemma 3.3]. \blacksquare

Lemma 2.7 (Continuity of the sesquilinear form) *The sesquilinear form $a(\cdot, \cdot)$ of the transmission problem defined by (1.6) is continuous on $H^1(B_R)$.*

Proof of Lemma 2.7. This follows from the Cauchy-Schwarz inequality and the inequalities (1.3), (1.4), (2.19). \blacksquare

Lemma 2.8 (Well-posedness from an a priori bound) *Suppose that, under the assumption of existence, the solution of the transmission problem (1.5) with $F(v) = \int_{B_R} f \bar{v}$ and $f \in L^2(B_R)$ satisfies*

$$\|u\|_{H_k^1(B_R)} \leq C(A, n, k, R) \|f\|_{L^2(B_R)} \quad \text{for all } k \geq k_0, \quad (2.20)$$

for some $C(A, n, k, R) > 0$ and $k_0 > 0$. Then the Helmholtz transmission problem of Definition 1.1 is well-posed: i.e., given $F \in (H^1(B_R))'$, let \tilde{u} satisfy the variational problem (1.5); then, if $k \geq k_0$, \tilde{u} exists, is unique, and the map $F \mapsto \tilde{u}$ is continuous (i.e., $C_{\text{sol}} < \infty$)

Proof. The inequalities (2.18), (1.3), and (1.4) imply that, for any $v \in H^1(B_R)$,

$$\begin{aligned} \Re b(v, v) &\geq A_{\min} \|\nabla v\|_{L^2(B_R)}^2 - k^2 n_{\max} \|v\|_{L^2(B_R)}^2 \\ &\geq A_{\min} \|v\|_{H_k^1(B_R)}^2 - k^2 (n_{\max} + A_{\min}) \|v\|_{L^2(B_R)}^2; \end{aligned} \quad (2.21)$$

i.e. $b(\cdot, \cdot)$ satisfies a Gårding inequality. A bound on the solution in terms of the data such as (2.20), under the assumption of existence, shows that the solution of the boundary value problem (if it exists) is unique. Since $b(\cdot, \cdot)$ is continuous and satisfies a Gårding inequality, the result then follows from Fredholm theory; see, e.g., [53, Theorems 2.27 and 2.34], [29, §6.2.3]. ■

Lemma 2.9 (Well-posedness and bound for $f \in L^2$ implies well-posedness and bound for $F \in (H^1)'$.) *Assume that A and n are such that, given $f \in L^2(B_R)$, the solution of the transmission problem of Definition 1.1 with $F(v) = \int_{B_R} f \bar{v}$ exists, is unique, and satisfies the bound (2.20) for some $C(A, n, k, R) > 0$ and $k_0 > 0$. Given $F \in (H^1(B_R))'$, let \tilde{u} satisfy the variational problem (1.5). Then \tilde{u} exists, is unique, and satisfies the bound*

$$\|\tilde{u}\|_{H_k^1(B_R)} \leq \frac{1}{\min(A_{\min}, n_{\min})} \left(1 + 2n_{\max} k C(A, n, k, R)\right) \|F\|_{(H_k^1(B_R))'}, \quad \text{for all } k \geq k_0.$$

References for the proof. This is proved in [38, Proof of Lemma 5.1] using the fact that $b(\cdot, \cdot)$ satisfies the Gårding inequality (2.21). Note that [38, Lemma 5.1] is a generalisation to the heterogeneous case of a well-known argument going back at least to [21, Text between Lemmas 3.3 and 3.4]. ■

In the rest of the paper, $|\cdot|_2$ denotes *both* the Euclidean vector norm on \mathbb{C}^d and the induced matrix norm on $\mathbb{C}^{d \times d}$, and $\|A\|_{L^2(B_R, \mathbb{C}^{d \times d})} := \| |A(\cdot)|_2 \|_{L^2(B_R)}$ for $A \in \mathbb{C}^{d \times d}$.

Lemma 2.10 (Solution of variational problems by approximation) *Given coefficients A and n satisfying the conditions in Definition 1.1, assume that there exist sequences of coefficients $(A^\ell)_{\ell=0}^\infty$ and $(n^\ell)_{\ell=0}^\infty$ satisfying, for every ℓ , the conditions in Definition 1.1 (possibly with different limits $n_{\min}, n_{\max}, A_{\min}$, and A_{\max} in the inequalities (1.3) and (1.4)), and such that (i)*

$$\|A - A^\ell\|_{L^2(B_R, \mathbb{C}^{d \times d})} \leq \frac{1}{\ell} \quad \text{and} \quad \|n - n^\ell\|_{L^2(B_R)} \leq \frac{1}{\ell} \quad \text{for all } \ell,$$

and (ii) there exists an $\ell_0 > 0$ and $C(k, R) > 0$ such that, for every $\ell \geq \ell_0$, the solution of the variational problem (1.5) with $F(v) = \int_{B_R} f \bar{v}$ and coefficients A^ℓ and n^ℓ exists, is unique, and satisfies the bound

$$\|u\|_{H_k^1(B_R)} \leq C(k, R) \|f\|_{L^2(B_R)}. \quad (2.22)$$

Then the solution of the variational problem (1.5) with $F(v) = \int_{B_R} f \bar{v}$ and with coefficients A and n exists, is unique, and satisfies the bound (2.22).

References for the proof. The proof is contained in [38, Pages 2901 and 2902] (with A_δ, n_δ replaced by A^ℓ, n^ℓ). ■

Lemma 2.10 holds with the $\|f\|_{L^2(B_R)}$ in the bound (2.22) replaced by $\|F\|_{(H_k^1(B_R))'}$ (with a different $C(k, R)$), thereby covering more general variational problems. In the rest of the paper, however, we only use Lemma 2.10 as stated, i.e. applied to variational problems with right-hand sides of the form $\int_{B_R} f \bar{v}$.

2.3 Traces and weighted Sobolev spaces

We repeatedly use the following standard trace result (see, e.g., [53, Theorem 3.37]).

Lemma 2.11 *If D is a bounded $C^{\ell-1,1}$ domain and $1/2 < s \leq \ell$, then the trace operator is bounded $H^s(D) \rightarrow H^{s-1/2}(\partial D)$.*

We use also the multiplicative trace inequality for Lipschitz D , i.e. that there exists $C_{\text{tr}} > 0$ such that

$$\|v\|_{L^2(\partial D)}^2 \leq C_{\text{tr}} \left(\frac{1}{\ell_D} \|v\|_{L^2(D)}^2 + \|v\|_{L^2(D)} \|v\|_{H^1(D)} \right) \quad \text{for all } v \in H^1(D), \quad (2.23)$$

where ℓ_D is the diameter of D (see [42, Theorem 1.5.1.10, last formula on Page 41]) and thus, with $\|\cdot\|_{H_k^1(D)}$ defined by (1.12),

$$k^{1/2} \|v\|_{L^2(\partial D)} \lesssim \|v\|_{H_k^1(D)} \quad \text{for all } v \in H^1(D). \quad (2.24)$$

We define $\|\cdot\|_{H_k^s(\partial D)}$ for $s = 1$ by

$$\|\phi\|_{H_k^1(\partial D)}^2 := \|\nabla_{\partial D} \phi\|_{L^2(\partial D)}^2 + k^2 \|\phi\|_{L^2(\partial D)}^2,$$

and for $0 < s < 1$ by interpolation, choosing the specific norm given by the complex interpolation method (equivalently, by real methods of interpolation appropriately defined and normalised; see, e.g., [20, Remark 3.6]). We then define the norms on $H^s(\partial D)$ and $H_k^s(\partial D)$ for $-1 \leq s < 0$ by duality,

$$\|\phi\|_{H^s(\partial D)} := \sup_{0 \neq \psi \in H^{-s}(\partial D)} \frac{|\langle \phi, \psi \rangle_{\partial D}|}{\|\psi\|_{H^{-s}(\partial D)}} \quad \text{and} \quad \|\phi\|_{H_k^s(\partial D)} := \sup_{0 \neq \psi \in H^{-s}(\partial D)} \frac{|\langle \phi, \psi \rangle_{\partial D}|}{\|\psi\|_{H_k^{-s}(\partial D)}},$$

for $\phi \in H^s(\partial D)$, where $\langle \phi, \psi \rangle_{\partial D}$ denotes the standard duality pairing that reduces to $(\phi, \psi)_{\partial D}$, the inner product on $L^2(\partial D)$, when $\psi \in L^2(\partial D)$. In the terminology of [20, Remark 3.8], with the norms we have selected, $\{H_k^s(\partial D) : -1 \leq s \leq 1\}$ are *exact interpolation scales*.

Finally, we need the weighted analogue of Lemma 2.11 with $s = 1$; see, e.g., [66, Theorem 5.6.4].

Lemma 2.12 (Trace and extension in k -weighted spaces) *If D is Lipschitz, then given $k_0 > 0$ there exists C , depending on k_0 but independent of k , such that*

$$\|v\|_{H_k^{1/2}(\partial D)} \leq C \|v\|_{H_k^1(D)} \quad \text{for all } v \in H^1(D) \text{ and } k \geq k_0.$$

Furthermore, there exists an extension operator $E : H^{1/2}(\partial D) \rightarrow H^1(D)$ such that, given $k_0 > 0$ there exists C' , depending on k_0 but independent of k , such that

$$\|E(\phi)\|_{H_k^1(D)} \leq C' \|\phi\|_{H_k^{1/2}(\partial D)} \quad \text{for all } \phi \in H^{1/2}(\Gamma). \quad (2.25)$$

3 Proof of Theorem 1.6 (the well-posedness result)

We follow the steps outlined in §1.2.5. In §3.1 we prove the analogue of Theorem 1.7 for smooth coefficients satisfying Condition 3.1. In §3.2 we show how coefficients satisfying Condition 1.4 can be approximated by coefficients satisfying Condition 3.1. Theorem 1.7 then follows from using Lemma 2.10. Having proved Theorem 1.7, Theorem 1.6 then follows from Lemma 2.9.

3.1 The analogue of Theorem 1.7 for a class of smooth coefficients

3.1.1 Statement of the result

Condition 3.1 (A particular class of smooth coefficients)

- $A \in C^\infty(\mathbb{R}^d, \text{SPD})$, $n \in C^\infty(\mathbb{R}^d, \text{SPD})$,
- there exist $A_{\min}, A_{\max}, n_{\min}$, and n_{\max} such that A and n satisfy (1.4) and (1.3), respectively,
- there exists $0 < R_0 < R$ such that $\text{supp}(1 - A) \subset B_{R_0}$ and $\text{supp}(1 - n) \subset B_{R_0}$,
-

$$x_d \frac{\partial A}{\partial x_d}(\mathbf{x}) \preceq 0 \quad \text{and} \quad x_d \frac{\partial n}{\partial x_d}(\mathbf{x}) \geq 0 \quad \text{for all } \mathbf{x} \in \mathbb{R}^d, \quad (3.1)$$

- $(A_{d\ell})(\mathbf{x}) = 0$ for $\ell = 1, \dots, d-1$ and for all $\mathbf{x} \in \mathbb{R}^d$.

Observe that the monotonicity conditions in (3.1) are the continuous versions of (1.8) and (1.9) from Condition 1.4. In addition, the conditions (3.1) along with the assumptions $\text{supp}(1-A) \subset B_{R_0}$ and $\text{supp}(1-n) \subset B_{R_0}$ imply that $A_{\min} \geq 1$ and $n_{\max} \leq 1$.

Lemma 3.2 (Bound for coefficients satisfying Condition 3.1) *There exist $C_{\text{wave}}, C_1 > 0$ such that the following holds. Given $R > R_0 > 0$, A and n satisfying Condition 3.1, and $f \in L^2(B_R)$, if $kR_0 \geq C_{\text{wave}}$, then the variational problem (1.5) with $F(v) = \int_{B_R} f \bar{v}$ and coefficients A and n has a unique solution that satisfies the bound (1.14).*

3.1.2 Overview of the ideas behind the proof of Lemma 3.2

The basic idea is to use the integrated Morawetz identity (2.13) in B_R with $v = u$,

- \mathbf{Z} given by the vector field in Definition 3.3 below; the key point is that \mathbf{Z} transitions from being equal to $x_d \mathbf{e}_d$ in B_{R_0} (and hence in a neighbourhood of $\text{supp}(1-A)$ and $\text{supp}(1-n)$) to being equal to \mathbf{x} in $\mathbb{R}^d \setminus B_{R_1}$ for some $0 < R_0 < R_1 < R$, with this transition controlled by a radial function χ transitioning from 0 (in B_{R_0}) to 1 (in $\mathbb{R}^d \setminus B_{R_1}$);
- $\beta = R$; and
- $2\alpha = \nabla \cdot \mathbf{Z} - q\chi$ for some $q \in [0, 1]$ (to be fixed later in the proof).

These choices allow us to use the inequality of Lemma 2.5 in (2.13) and obtain that $\int_{B_R} P(u) \leq 0$. The expression for $P(u)$ (2.12) can then be simplified, and bounded below using the monotonicity assumptions (3.1) on A and n , with the result that

$$\begin{aligned} & \int_{B_R} \left(2|\partial_d u|^2(1-\chi) + |\nabla u|^2(2-q)\chi + qk^2|u|^2\chi + 2r|\partial_r u|^2\chi' \right) dx - 2\Re \int_{B_R} x_d \partial_d \bar{u} \partial_r u \chi' \\ & \leq -2kR\Im \int_{B_R} f \bar{u} + \Re \int_{B_R} f \left(2x_d \partial_d \bar{u} (1-\chi) + 2r \partial_r \bar{u} \chi + 2\alpha \bar{u} \right) + \int_{B_R} \Delta \alpha |u|^2. \end{aligned} \quad (3.2)$$

Observe that when $\chi = 0$ (i.e. in B_{R_0}) we only have control of $|\partial_d u|^2$ in the first integral on the left-hand side, but in $\text{supp}(\chi)$ we have control of $|\nabla u|^2 + k^2|u|^2$.

The rest of the argument consists of

1. getting rid of the sign-indefinite ‘‘cross’’ term in the second integral on the left-hand side of (3.2);
2. using the following Poincaré-Friedrichs-type inequality [22, Lemma 2.7] to put $|u|^2$ back in B_{R_0} (i.e. where $\chi = 0$),

$$\int_{B_{2R}} |v|^2 \leq 8 \int_{B_{\sqrt{13}R} \setminus B_{2R}} |v|^2 + 4R^2 \int_{B_{\sqrt{13}R}} |\partial_d v|^2 \quad \text{for all } R > 0 \text{ and } v \in H^1(\mathbb{R}^d);$$

3. using the following consequence of Green’s identity and the inequality (2.18) to put $|\nabla u|^2$ back in B_{R_0} ,

$$\min \{A_{\min}, 1\} \int_{B_R} |\nabla u|^2 \leq \max \{n_{\max}, 1\} \int_{B_R} |u|^2 + \Re \int_{B_R} f \bar{u}; \quad (3.3)$$

4. bounding the term on the right-hand side of (3.2) involving the Laplacian of α ;
5. using the inequality $2ab \leq \delta a^2 + \delta^{-1}b^2$ (for $a, b, \delta > 0$) on the other terms on the right-hand side of (3.2).

Regarding 1: this involves imposing a constraint on the growth of χ (see Point (ii) in Definition 3.3 and the discussion below this definition). Regarding 2: here is the place where we lose powers of k compared to the nontrapping estimate, since, in the Poincaré-Friedrichs-type inequality, $|\partial_d u|^2$ is bounded below by $|u|^2$ without a corresponding factor of k^2 .

The paper [22] considers the constant-coefficient Helmholtz equation posed outside a class of obstacles, the prototypical example of which is two aligned cubes (so that there exist weakly-trapped rays between the two components of the obstacle). The arguments in [22] use the same vector field \mathbf{Z} we use here, and, in fact, [22] obtains exactly the inequality (3.2) in the course of its arguments. The details of the Steps 1-5 above are therefore exactly as in [22], and so we do not repeat the details below, instead making precise reference to the relevant results in [22].

3.1.3 The proof of Lemma 3.2

Definition 3.3 (The vector field \mathbf{Z}) *Given $0 < R_0 < R_1 < \infty$ such that $\text{supp}(1 - \mathbf{A}) \subset B_{R_0}$ and $\text{supp}(1 - n) \subset B_{R_0}$ and $\chi \in C^3[0, \infty)$ with*

- (i) $\chi(r) = 0$ for $0 \leq r \leq R_0$, $\chi(r) = 1$, for $r \geq R_1$, $0 < \chi(r) < 1$, for $R_0 < r < R_1$; and
- (ii) $0 \leq r\chi'(r) < 4$, for $r > 0$;

let

$$\mathbf{Z}(\mathbf{x}) := \mathbf{e}_d x_d (1 - \chi(r)) + \mathbf{x} \chi(r), \quad \mathbf{x} \in \mathbb{R}^d. \quad (3.4)$$

The requirement (ii) on χ is needed to control the term $2\Re \int_{B_R} x_d \partial_d \bar{u} \partial_r u \chi'(r) dx$ on the left-hand side of (3.2), ensuring that this left-hand side is bounded below by a multiple of $\int_{B_R} (|\partial_d u|^2 + \chi |\nabla u|^2) dx$. This requirement imposes a constraint on R_1/R_0 ; indeed, [22, Remark 1.5] shows that if χ satisfies Points (i) and (ii) in Definition 3.3, then $R_1/R_0 > e^{1/4} \approx 1.284$, and, conversely, if $R_1/R_0 > e^{1/4}$, then there exists a $\chi \in C^3[0, \infty)$ satisfying Points (i) and (ii) in Definition 3.3.

Lemma 3.4 *Let u be the solution of the transmission problem of Definition 1.1, with $F(v) = \int_{B_R} f \bar{v}$ and coefficients \mathbf{A} and n satisfying Condition 3.1. Let α be defined by*

$$2\alpha := \nabla \cdot \mathbf{Z} - q \chi(r), \quad (3.5)$$

for some $q \in [0, 1]$, with χ as in Definition 3.3. Then u exists and the inequality (3.2) holds.

Proof of Lemma 3.4. Since \mathbf{A} and n satisfying Condition 3.1 are C^∞ , the existence of u follows from the unique continuation principle (see the references in §1.2.2) and Fredholm theory (see the proof of Lemma 2.8). Since $\mathbf{A} \in C^\infty$, $u \in H^2(B_R)$ for any $R > 0$ by H^2 regularity for the operator $\nabla \cdot (\mathbf{A}\nabla)$; see, e.g., [53, Theorem 4.16]. By Lemmas 2.4 and 2.5,

$$\int_{B_R} P(u) \leq 0, \quad (3.6)$$

where $P(u)$ is defined by (2.12). We first claim that, in B_R ,

$$P(u) \geq -2\Re(\overline{\mathbf{Z}u} f) - q\chi |\nabla u|^2 + q\chi k^2 |u|^2 + 2\Re\langle \mathbf{A}\nabla u, \partial \mathbf{Z} \nabla u \rangle - \Delta \alpha |u|^2. \quad (3.7)$$

Indeed, this follows from using (i) the conditions on $\partial \mathbf{A} / \partial x_d$ and $\partial n / \partial x_d$ (3.1), noting that when $\mathbf{A} \neq \mathbf{I}$ and $n \neq 1$, $\mathbf{Z} = x_d \mathbf{e}_d$, (ii) the definitions of α (3.5) and $\beta = R$, (iii) the fact that when $\chi \neq 0$, $\mathbf{A} = \mathbf{I}$ and $n = 1$, (iv) the fact that α is constant when $\mathbf{A} \neq \mathbf{I}$.

To deal with the term $\Re\langle \mathbf{A}\nabla u, \partial \mathbf{Z} \nabla u \rangle$, we first observe that (with the summation convention for the indices i and j but not d)

$$\langle \nabla v, \partial \mathbf{Z} \nabla v \rangle = \partial_i Z_j \partial_i \bar{v} \partial_j v = |\partial_{dv}|^2 (1 - \chi(r)) + |\nabla v|^2 \chi(r) + (r |\partial_r v|^2 - x_d \overline{\partial_{dv}} \partial_r v) \chi'(r). \quad (3.8)$$

Next, when $\mathbf{A} \neq \mathbf{I}$, $\chi = 0$ so $\mathbf{Z} = x_d \mathbf{e}_d$; therefore $((\partial \mathbf{Z}) \nabla u)_i = \delta_{id} \partial_d u$, so that (2.10) above holds. The assumption that $(\mathbf{A}_{d\ell}) = 0$ for $\ell = 1, \dots, d-1$ implies that, when $\mathbf{A} \neq \mathbf{I}$, $\langle \mathbf{A}\nabla u, \partial \mathbf{Z} \nabla u \rangle = (\mathbf{A})_{dd} |\partial_d u|^2$. The fact that $A_{\min} \geq 1$ (noted after Condition 3.1) implies that $(\mathbf{A})_{dd} \geq 1$, and so

$$\text{when } \mathbf{A} \neq \mathbf{I}, \quad \langle \mathbf{A}\nabla u, \partial \mathbf{Z} \nabla u \rangle \geq |\partial_d u|^2. \quad (3.9)$$

Since $\chi = 0$ when $\mathbf{A} \neq \mathbf{I}$, we can combine (3.8) and (3.9) to obtain that

$$\langle \mathbf{A} \nabla v, \partial \mathbf{Z} \nabla v \rangle \geq |\partial_d v|^2 (1 - \chi(r)) + |\nabla v|^2 \chi(r) + (r |\partial_r v|^2 - x_d \overline{\partial_d v} \partial_r v) \chi'(r). \quad (3.10)$$

Combining (3.7) and (3.10) we have

$$\begin{aligned} P(u) \geq & -2\Re(\overline{\mathbf{Z}u} f_{\text{out}}) + 2|\partial_d u|^2 (1 - \chi(r)) + |\nabla u|^2 (2 - q) \chi(r) + qk^2 |u|^2 \chi(r) \\ & + 2r |\partial_r u|^2 \chi'(r) - 2\Re(x_d \overline{\partial_d u} \partial_r u \chi'(r)) - \Delta \alpha |u|^2. \end{aligned}$$

and (3.2) then follows from (3.6) by expanding the $\overline{\mathbf{Z}u} f$ term using that

$$\mathbf{Z} \cdot \nabla u = x_d \partial_d u (1 - \chi(r)) + r \partial_r u \chi(r).$$

Proof of Lemma 3.2. The inequality (3.2) in Lemma 3.4 is identical to the inequality that is the result of [22, Lemma 3.1]. The results [22, Lemmas 3.2, 3.3, 3.4, 3.5] (discussed in §3.1.2) then go through ad verbatim (with the value of q fixed in [22, Lemma 3.5]); in seeing this, observe that, since $A_{\min} \geq 1$ and $n_{\max} \leq 1$, the factors in front of the integrals of $|\nabla u|^2$ and $|u|^2$ in (3.3) are both one, as they are in the analogous inequality [22, Equation 2.11]. Lemma 3.2 is then a consequence of [22, Lemma 3.5] (see [22, Proof of Theorem 1.10 from Lemma 3.5]). ■

Remark 3.5 (Explicit expressions for C_{wave} , and k_0) C_1 is given in terms of χ in [22, Equation 3.22] (see the discussion in [22, Proof of Theorem 1.10 from Lemma 3.5]).

C_{wave} is given in terms of the function χ in Definition 3.3 in [22, Equation 3.20]. Indeed, to see that [22, Equation 3.20] is a condition of the form $kR_0 \geq C_{\text{wave}}$ with C_{wave} dependent only on χ , we need to show that $(R_0)^2 m_\alpha(R)$ is a dimensionless quantity depending only on χ , where $m_\alpha(R) := \sup_{\mathbf{x} \in B_R} \Delta \alpha(\mathbf{x})$ and $2\alpha = \nabla \cdot \mathbf{Z} - q\chi$ (as in §3.1.2), with \mathbf{Z} defined by (3.4). By definition, α is constant for $R \geq R_1$ (see [22, Equation 3.15]), and thus $m_\alpha(R) = m_\alpha(R_1)$. The only constraint on R_1 is that R_1/R_0 is sufficiently large (see the discussion below Definition 3.3); therefore, we can choose R_1 to be proportional to R_0 , and thus $(R_0)^2 m_\alpha(R)$ is a dimensionless quantity depending only on χ as claimed.

3.2 Approximation of \mathbf{A} and n satisfying Condition 1.4 by \mathbf{A}_δ and n_δ satisfying Condition 3.1

Lemma 3.6 (Approximation of \mathbf{A} and n satisfying Condition 1.4) *Given \mathbf{A} and n satisfying Condition 1.4, there exist $(\mathbf{A}^\ell)_{\ell=0}^\infty, (n^\ell)_{\ell=0}^\infty$ such that, for ℓ sufficiently large, (i) \mathbf{A}^ℓ and n^ℓ satisfy Condition 3.1, and (ii)*

$$\|\mathbf{A}^\ell - \mathbf{A}\|_{L^2(B_R, \mathbb{C}^{d \times d})} \leq \frac{1}{\ell} \quad \text{and} \quad \|n^\ell - n\|_{L^2(B_R)} \leq \frac{1}{\ell}.$$

Proof. The idea of the proof is to mollify \mathbf{A} and n to approximate them by families of C^∞ functions \mathbf{A}_δ and n_δ that satisfy Condition 3.1. However, before mollification, we first must approximate \mathbf{A} and n by functions that are constant in the x_d direction in a neighbourhood of $x_d = 0$. To see why this is necessary, suppose that, in some compact set, n is only a function of x_d , and equals C for $0 \leq x_d < c$ and $C - x_d$ for $-c < x_d < 0$ (observe that this function satisfies the monotonicity assumption (1.9) in $-c < x_d < c$). Then, with n_δ the standard mollification of n , given $\delta > 0$, there exists an $x_d^* > 0$ such that $(\partial n_\delta / \partial x_d)|_{x_d=x_d^*} \leq 0$, violating the requirement on n_δ in (3.1).

Let $0 < R_0 < R$ be such that $\text{supp}(\mathbf{I} - \mathbf{A})$ and $\text{supp}(1 - n)$ are both $\subset B_{R_0}$. Given $\delta_1 > 0$, let

$$\tilde{\mathbf{A}}_{\delta_1}(\mathbf{x}) := \begin{cases} A_{\max} \mathbf{I}, & \text{for } \mathbf{x} \in \{(\mathbf{x}', x_d) : |\mathbf{x}'| \leq R_0, |x_d| \leq \delta_1\}, \\ \mathbf{A}(\mathbf{x}), & \text{otherwise,} \end{cases} \quad (3.11)$$

and let

$$\tilde{n}_{\delta_1}(\mathbf{x}) := \begin{cases} n_{\min} \mathbf{I}, & \text{for } \mathbf{x} \in \{(\mathbf{x}', x_d) : |\mathbf{x}'| \leq R_0, |x_d| \leq \delta_1\}, \\ n(\mathbf{x}), & \text{otherwise,} \end{cases}$$

Observe that (i), $\tilde{\mathbf{A}}_{\delta_1}$ and \tilde{n}_{δ_1} satisfy Condition 1.4, (ii) $\text{supp}(1 - \tilde{\mathbf{A}}_{\delta_1})$ and $\text{supp}(1 - \tilde{n}_{\delta_1})$ are both $\subset B_{R_1(\delta_1)}$, where $R_1(\delta_1) := \sqrt{R_0^2 + \delta_1^2}$, and (iii) there exists $C_d > 0$ (depending only on the dimension d) such that

$$\|\mathbf{A} - \tilde{\mathbf{A}}_{\delta_1}\|_{L^2(B_R, \mathbb{C}^{d \times d})} \leq C_d(R_0)^{d-1} \delta_1 A_{\max} \quad \text{and} \quad \|n - \tilde{n}_{\delta_1}\|_{L^2(B_R)} \leq C_d(R_0)^{d-1} \delta_1 n_{\max}. \quad (3.12)$$

Let $\psi \in C_0^\infty(\mathbb{R}^d)$ be defined by

$$\psi(\mathbf{x}) := \begin{cases} C \exp((|\mathbf{x}|^2 - 1)^{-1}) & \text{if } |\mathbf{x}| < 1, \\ 0 & \text{if } |\mathbf{x}| \geq 1, \end{cases}$$

where C is chosen so that $\int_{\mathbb{R}^d} \psi(\mathbf{x}) d\mathbf{x} = 1$. Define $\psi_\delta(\mathbf{x}) := \delta^{-d} \psi(\mathbf{x}/\delta)$, so that $\psi_\delta(\mathbf{x}) = 0$ if $|\mathbf{x}| > \delta$ and $\int_{\mathbb{R}^d} \psi_\delta(\mathbf{x}) d\mathbf{x} = 1$. Let

$$(\tilde{\mathbf{A}}_{\delta_1})_\delta(\mathbf{x}) := (\tilde{\mathbf{A}}_{\delta_1} * \psi_\delta)(\mathbf{x}) = \int_{|\mathbf{y}| < \delta} \tilde{\mathbf{A}}_{\delta_1}(\mathbf{x} - \mathbf{y}) \psi_\delta(\mathbf{y}) d\mathbf{y},$$

where the convolution is understood element-wise, and similarly

$$(\tilde{n}_{\delta_1})_\delta(\mathbf{x}) := (\tilde{n}_{\delta_1} * \psi_\delta)(\mathbf{x}) = \int_{|\mathbf{y}| < \delta} \tilde{n}_{\delta_1}(\mathbf{x} - \mathbf{y}) \psi_\delta(\mathbf{y}) d\mathbf{y}.$$

Standard properties of mollifiers (see, e.g., [29, §C.4 Theorem 6]) imply that

- $(\tilde{\mathbf{A}}_{\delta_1})_\delta, (\tilde{n}_{\delta_1})_\delta \in C^\infty(\mathbb{R}^d)$,
- given $R > 0$, both $\|(\tilde{\mathbf{A}}_{\delta_1})_\delta - \tilde{\mathbf{A}}_{\delta_1}\|_{L^2(B_R; \mathbb{C}^{d \times d})}$ and $\|(\tilde{n}_{\delta_1})_\delta - \tilde{n}_{\delta_1}\|_{L^2(B_R)}$ $\rightarrow 0$ as $\delta \rightarrow 0$, and
- $n_{\min} \leq (\tilde{n}_{\delta_1})_\delta \leq n_{\max}$ and $A_{\min} \preceq (\tilde{\mathbf{A}}_{\delta_1})_\delta \preceq A_{\max}$ for all $\mathbf{x} \in \mathbb{R}^d$.

Since $(\tilde{\mathbf{A}}_{\delta_1})_\delta$ is formed from $\tilde{\mathbf{A}}_{\delta_1}$ by elementwise convolution, the condition $((\tilde{\mathbf{A}}_{\delta_1})_\delta)_{d\ell}(\mathbf{x}) = 0$ for $\ell = 1, \dots, d-1$ and for all $\mathbf{x} \in \mathbb{R}^d$ in Condition 3.1 follows from the corresponding condition on $\tilde{\mathbf{A}}_{\delta_1}$, which follows from the corresponding condition on \mathbf{A} in Condition 1.4. Furthermore, since $\text{supp}(1 - \tilde{\mathbf{A}}_{\delta_1})$ and $\text{supp}(1 - \tilde{n}_{\delta_1}) \subset B_{R_1(\delta_1)}$, the definitions of \mathbf{A}_δ and n_δ imply that $\text{supp}(1 - \mathbf{A}_\delta)$ and $\text{supp}(1 - n) \subset B_{R_1(\delta_1) + \delta}$ which is $\subset B_R$ for $\delta < R - R_1(\delta_1) = R - \sqrt{R_0^2 + \delta_1^2}$.

We now show that, when δ is sufficiently small, $(\tilde{\mathbf{A}}_{\delta_1})_\delta$ and $(\tilde{n}_{\delta_1})_\delta$ satisfy the monotonicity conditions (3.1) (with \mathbf{A} replaced by $(\tilde{\mathbf{A}}_{\delta_1})_\delta$ and n replaced by $(\tilde{n}_{\delta_1})_\delta$). Observe that

$$(\tilde{\mathbf{A}}_{\delta_1})_\delta(\mathbf{x} + h\mathbf{e}_d) - (\tilde{\mathbf{A}}_{\delta_1})_\delta(\mathbf{x}) = \int_{|\mathbf{y}| < \delta} \left[\tilde{\mathbf{A}}_{\delta_1}(\mathbf{x} + h\mathbf{e}_d - \mathbf{y}) - \tilde{\mathbf{A}}_{\delta_1}(\mathbf{x} - \mathbf{y}) \right] \psi_\delta(\mathbf{y}) d\mathbf{y}. \quad (3.13)$$

We claim that, when $\delta \leq \delta_1$, (i) when $x_d > 0$, the integrand on the right-hand side of (3.13) is $\preceq 0$ for all $h \geq 0$, and (ii) when $x_d < 0$, the integrand on the right-hand side of (3.13) is $\succeq 0$ for all $h \geq 0$. To see (i), first recall that, from its definition (3.11), $\tilde{\mathbf{A}}_{\delta_1}(\mathbf{z})$ is constant in the z_d direction when $|z_d| \leq \delta_1$. If $x_d \geq \delta_1$ then $x_d - y_d > 0$, and the integrand on the right-hand side of (3.13) is $\preceq 0$ by (1.8). If $0 < x_d < \delta_1$, $x_d - y_d$ is no longer > 0 for all $|\mathbf{y}| < \delta$, but $x_d - y_d > -\delta_1$, and the fact that $\tilde{\mathbf{A}}_{\delta_1}(\mathbf{z})$ is constant in the z_d direction when $|z_d| \leq \delta_1$ implies that the integrand on the right-hand side of (3.13) is either $= 0$ (when $x_d - y_d + h \leq \delta_1$) or $\preceq 0$ by (1.8) (when $x_d - y_d + h > \delta_1$). The proof of (ii) is similar. We have therefore shown that, for δ sufficiently small,

$$x_d \left[(\tilde{\mathbf{A}}_{\delta_1})_\delta(\mathbf{x} + h\mathbf{e}_d) - (\tilde{\mathbf{A}}_{\delta_1})_\delta(\mathbf{x}) \right] \preceq 0 \quad \text{for all } h \geq 0;$$

since $(\tilde{\mathbf{A}}_{\delta_1})_\delta \in C^\infty(\mathbb{R}^d)$ this implies that $x_d(\partial(\tilde{\mathbf{A}}_{\delta_1})_\delta/\partial x_d)(\mathbf{x}) \preceq 0$. In an essentially-identical way (with inequality in the sense of quadratic forms replaced by standard inequality), we find that $x_d(\partial(\tilde{n}_{\delta_1})_\delta/\partial x_d)(\mathbf{x}) \geq 0$.

We have therefore shown that $(\tilde{\mathbf{A}}_{\delta_1})_\delta$ and $(\tilde{n}_{\delta_1})_\delta$ satisfy Condition 3.1 for $\delta \leq \min\{\delta_1, R - \sqrt{R_0^2 + \delta_1^2}\}$, where the first term in the minimum ensures that $(\tilde{\mathbf{A}}_{\delta_1})_\delta$ and $(\tilde{n}_{\delta_1})_\delta$ satisfy the monotonicity condition (3.1), and the second term in the minimum ensures that $\text{supp}(1 - (\tilde{\mathbf{A}}_{\delta_1})_\delta)$ and $\text{supp}(1 - (\tilde{n}_{\delta_1})_\delta)$ are both $\subset B_R$.

We now define A^ℓ to be $(\tilde{A}_{\delta_1})_\delta$ for specific δ_1 and δ , and similarly for n^ℓ . Indeed, from the properties of mollifiers above we have that, given $\delta_1 > 0$, $\varepsilon > 0$, there exists $\delta^* = \delta^*(A, d, \delta_1, \varepsilon) > 0$ such that

$$\|(\tilde{A}_{\delta_1})_\delta - \tilde{A}_{\delta_1}\|_{L^2(B_R; \mathbb{C}^{d \times d})} \leq \frac{\varepsilon}{2} \quad \text{for all } \delta \leq \delta^*(A, d, \delta_1, \varepsilon). \quad (3.14)$$

Set $\delta_1 := (2C_d(R_0)^{d-1}A_{\max}\ell)^{-1}$; then, if $\delta \leq \delta^*(A, d, \delta_1, \ell^{-1})$, the inequalities (3.12) and (3.14) imply that

$$\begin{aligned} \|A - (\tilde{A}_{\delta_1})_\delta\|_{L^2(B_R; \mathbb{C}^{d \times d})} &\leq \|A - \tilde{A}_{\delta_1}\|_{L^2(B_R; \mathbb{C}^{d \times d})} + \|\tilde{A}_{\delta_1} - (\tilde{A}_{\delta_1})_\delta\|_{L^2(B_R; \mathbb{C}^{d \times d})}, \\ &\leq C_d(R_0)^{d-1}\delta_1 A_{\max} + \frac{1}{2\ell} \leq \frac{1}{2\ell} + \frac{1}{2\ell} = \frac{1}{\ell}. \end{aligned}$$

Recall from above that $(\tilde{A}_{\delta_1})_\delta$ and $(\tilde{n}_{\delta_1})_\delta$ satisfy Condition 3.1 when $\delta \leq \min\{\delta_1, R - \sqrt{R_0^2 + \delta_1^2}\}$. We therefore set

$$\delta := \min \left\{ \delta_1, R - \sqrt{R_0^2 + \delta_1^2}, \delta^*(A, d, \delta_1, \ell^{-1}) \right\} \quad \text{and} \quad A^\ell := (\tilde{A}_{\delta_1})_\delta;$$

then $\|A - A^\ell\|_{L^2(B_R; \mathbb{R}^{d \times d})} \leq \ell^{-1}$ and A^ℓ satisfies Condition 3.1. The definition of n^ℓ follows in an essentially-identical way. \blacksquare

4 Proofs of Lemma 1.13, Theorem 1.14, and Corollary 1.15

If $v : D_{\text{in}} \times Y \rightarrow \mathbb{C}$, let $v^\varepsilon : D_{\text{in}} \rightarrow \mathbb{C}$ denote the function

$$v^\varepsilon(\mathbf{x}) := v\left(\mathbf{x}, \left\{\frac{\mathbf{x}}{\varepsilon}\right\}\right),$$

where $\{\mathbf{y}\} = \mathbf{y} \bmod 1$. (As a special case of this, if $v : Y \rightarrow \mathbb{C}$, then $v^\varepsilon(\mathbf{x}) := v(\{\mathbf{x}/\varepsilon\})$.) Given such a v ,

$$\frac{\partial v^\varepsilon}{\partial x_j} = \left(\frac{\partial v}{\partial x_j} + \frac{1}{\varepsilon} \frac{\partial v}{\partial y_j} \right)^\varepsilon. \quad (4.1)$$

From here on, when we use the notation \lesssim , the omitted constant only depends on \hat{n} , $\hat{\mathbf{A}}$, and D_{in} .

4.1 The homogenized problem

4.1.1 The homogenized coefficients

The homogenized coefficient n^H is the mean value of \hat{n} over the periodic cell Y , i.e., (recalling that $|Y| = 1$)

$$n^H := \int_Y \hat{n}. \quad (4.2)$$

The definition of A^H requires the auxiliary functions $\hat{\chi}_j$, $j = 1, 2, 3$, and matrices $\hat{\mathbf{C}}$ and $\hat{\mathbf{B}}$.

Let $H_{\#}^1(Y)$ be the subspace of $H_{\text{per}}^1(Y)$ consisting of functions with zero mean. The function $\hat{\chi}_j \in H_{\#}^1(Y)$ is defined as the solution of

$$-\nabla_{\mathbf{y}} \cdot (\hat{\mathbf{A}} \nabla_{\mathbf{y}} \hat{\chi}_j) = -\frac{\partial(\hat{\mathbf{A}})_{j\ell}}{\partial y_\ell} \quad (4.3)$$

where the index ℓ on the right-hand side is summed over, and the derivative on the right-hand side is understood in a distributional sense. Lemma A.2 shows that $\hat{\chi}_j$, $j = 1, 2, 3$, exists, is unique, and is in $H^{1+s}(Y) \cap C^1(\mathcal{P})$ (i.e., C^1 on each element of the partition \mathcal{P}) for some $s > 0$, with

$$\|\hat{\chi}_j\|_{H^{1+s}(Y)} \lesssim 1 \quad \text{and} \quad \|\hat{\chi}_j\|_{W^{1,\infty}(\mathcal{P})} \lesssim 1, \quad (4.4)$$

where both the omitted constant and s depend only on $\hat{\mathbf{A}}$. The matrix $\hat{\mathbf{C}}$ is defined by

$$(\hat{\mathbf{C}})_{j\ell} := \frac{\partial \hat{\chi}_\ell}{\partial y_j}, \quad 1 \leq j, \ell \leq d. \quad (4.5)$$

Because of (4.4), $(\widehat{\mathbf{C}})_{j\ell} \in H^s(Y) \cap C^0(\mathcal{P})$ for some $s > 0$ with

$$\|\widehat{\mathbf{C}}\|_{H^s(Y)} \lesssim 1 \quad \text{and} \quad \|\widehat{\mathbf{C}}\|_{L^\infty(Y)} \lesssim 1.$$

With

$$\widehat{\mathbf{B}} := \widehat{\mathbf{A}}(1 - \widehat{\mathbf{C}}), \tag{4.6}$$

the homogenized matrix coefficient \mathbf{A}^H is the mean value of $\widehat{\mathbf{B}}$ over the periodic cell Y , i.e.,

$$(\mathbf{A}^H)_{j\ell} = \int_Y (\widehat{\mathbf{B}})_{j\ell}, \quad 1 \leq j, \ell \leq d; \tag{4.7}$$

note that $\mathbf{A}^H \in \text{SPD}$ by, e.g., [7, Remarks 2.6 and 2.7], [27, §6.3]. We now claim that $\widehat{\mathbf{B}} \in H^s(Y) \cap C^0(\mathcal{P}) \cap L^\infty(Y)$ for some $0 < s < 1/2$; indeed, this follows from the facts that $\widehat{\mathbf{C}} \in H^s(Y)$, $\widehat{\mathbf{A}}$ is (at least) piecewise $C^{0,1}$ (by Condition 1.10), and a piecewise H^s function for $s < 1/2$ is in $H^s(Y)$ (by the definition of the Slobodeckij seminorm).

4.1.2 Basic properties of the homogenized problem

We now prove Lemma 1.13, i.e., well-posedness of the homogenized problem.

Proof of Lemma 1.13. We first show that if \widehat{n} and $\widehat{\mathbf{A}}$ are admissible periodic patterns (in the sense of Definition 1.10), then n^H and \mathbf{A}^H satisfy Condition 1.4; once this is established, the bound (1.18) follows from Theorem 1.6.

Since both n^H and \mathbf{A}^H are constant in D_{in} , they are clearly independent of x_d ; the monotonicity conditions (1.8) and (1.9) therefore hold if $n^H \leq 1$ and $\mathbf{A}^H \succeq \mathbf{I}$. Recall from the discussion below Condition 1.4 that $n_{\text{max}} \leq 1$ and $A_{\text{min}} \geq 1$. Since n^H is obtained from \widehat{n} through simple averaging (4.2), $n^H \leq 1$. While the averaging process is more complicated for \mathbf{A}^H , [27, Theorem 13.7] implies that $\mathbf{A}^H \succeq \mathbf{I}$.

Therefore, to show that n^H and \mathbf{A}^H satisfy Condition 1.4, it only remains to show that $\mathbf{A}_{d,\ell}^H = 0$ for $\ell = 1, \dots, d-1$. By (4.7),

$$\mathbf{A}^H = \int_Y \widehat{\mathbf{B}} = \int_Y \widehat{\mathbf{A}} - \int_Y \widehat{\mathbf{A}}\widehat{\mathbf{C}},$$

it is sufficient to show that $(\widehat{\mathbf{C}})_{\ell d} = 0$ for $\ell = 1, \dots, d-1$. By the definition of $\widehat{\mathbf{C}}$ (4.5),

$$(\widehat{\mathbf{C}})_{d\ell} := \frac{\partial \widehat{\chi}_\ell}{\partial y_d} = 0$$

since $\widehat{\chi}$ is independent of y_d , and

$$(\widehat{\mathbf{C}})_{\ell d} := \frac{\partial \widehat{\chi}_d}{\partial y_\ell};$$

however, $\widehat{\chi}_d = 0$ since the right-hand side of (4.4) is

$$-\sum_{\ell=1}^d \frac{\partial(\widehat{\mathbf{A}})_{d\ell}}{\partial y_\ell} = -\frac{\partial(\widehat{\mathbf{A}})_{dd}}{\partial y_d} = 0,$$

because $\widehat{\mathbf{A}}$ is independent of y_d .

If D_{in} is star-shaped, since $\mathbf{A}^H \succeq \mathbf{I}$ and $n^H \leq 1$, \mathbf{A}^H and n^H satisfy [38, Condition 2.6] with $\mu_1 = A_{\text{min}} = 1$ and $\mu_2 = n_{\text{min}}$ (see the example in [38, Condition 2.10]) and so, by [38, Theorem 2.7], if $F(v) = \int_{B_R} f \bar{v}$, then

$$\|u_0\|_{H_k^1(B_R)} \leq \frac{2}{\sqrt{n_{\text{min}}}} \sqrt{R^2 + \frac{1}{n_{\text{min}}} \left(R + \frac{d-1}{2k}\right)^2} \|f\|_{L^2(B_R)} \quad \text{for all } k > 0;$$

the bound (1.19) follows from combining this with Lemma 2.9. ■

Lemma 4.1 (Shift property for the homogenized problem) *If Γ is $C^{1,1}$, then for all $g \in L^2(B_R)$, if $v \in H^1(B_R)$ satisfies*

$$-\nabla \cdot (\mathbf{A}^H \nabla v) = g \text{ in } B_R$$

then $v \in H^2(D_{\text{in}})$ with

$$|v|_{H^2(D_{\text{in}})} \lesssim \|g\|_{L^2(B_R)}.$$

Proof. Since \mathbf{A}^H is constant in both D_{in} and D_{out} , Lemma 4.1 holds if Γ is $C^{1,1}$ by, e.g., [53, Theorem 4.18]. (If Γ has edges or corners, similar shift properties hold but with the angles of edges/corners constrained by the values of \mathbf{A}^H , see, e.g., [28].) ■

We abbreviate $C_{\text{sol}}(\mathbf{A}^H, n^H, k, R, R_0)$ by $C_{\text{sol},H}$ in the rest of the paper.

Lemma 4.2 (Bounds on u_0) *Assume that \hat{n} and $\hat{\mathbf{A}}$ satisfy Condition 1.10, and Γ is $C^{1,1}$. Then, for all $f \in L^2(B_R)$, the solution u_0 of (1.5) with coefficients n^H and \mathbf{A}^H and $F(v) = \int_{B_R} f \bar{v}$ satisfies*

$$\|u_0\|_{H^2(B_R)} + k \|u_0\|_{H_k^1(B_R)} \lesssim C_{\text{sol},H} \|f\|_{L^2(B_R)}. \quad (4.8)$$

Proof. The bound on $\|u\|_{H_k^1(B_R)}$ in (4.8) follows from the definition of $C_{\text{sol},H}$. The bound on $\|u\|_{H^2(B_R)}$ in (4.8) follows from Lemma 4.1 with $v = u$, $g = n^H k^2 u + f$, and $\alpha = 0$, and the fact that $C_{\text{sol},H} \gtrsim 1$ (as noted below (1.12)). ■

4.2 The first-order, second-order, and boundary correctors

Periodic homogenization relies on the formal asymptotic expansion

$$u_\varepsilon(\mathbf{x}) = u_0(\mathbf{x}) + \varepsilon u_1^\varepsilon(\mathbf{x}) + \varepsilon^2 u_2^\varepsilon(\mathbf{x}) + \dots,$$

where u_0 is the homogenized solution and u_1, u_2 are “two scale” functions usually called “correctors”. Since, in our case, the homogenization process only takes place in D_{in} , we need an additional corrector, called the “boundary corrector”, to deal with the interface Γ .

4.2.1 The first-order corrector

The first-order corrector $u_1 : D_{\text{in}} \times Y \rightarrow \mathbb{C}$ is defined by

$$u_1(\mathbf{x}, \mathbf{y}) := -\hat{\chi}_j(\mathbf{y}) \frac{\partial u_0}{\partial x_j}(\mathbf{x}). \quad (4.9)$$

Lemma 4.3 (Key properties of the first-order corrector)

$$\nabla_{\mathbf{y}} u_1 = -\hat{\mathbf{C}} \nabla u_0 \quad \text{for a.e. } \mathbf{y} \in Y, \quad (4.10)$$

and

$$k \|u_1^\varepsilon\|_{L^2(D_{\text{in}})} + \|(\nabla_{\mathbf{x}} u_1)^\varepsilon\|_{L^2(D_{\text{in}})} \lesssim k \|u_0\|_{H_k^1(B_R)} + |u_0|_{H^2(D_{\text{in}})}. \quad (4.11)$$

Furthermore,

$$\|u_1^\varepsilon\|_{H_k^1(B_R)} \lesssim (1 + (k\varepsilon)^{-1}) \left(|u_0|_{H^2(D_{\text{in}})} + k \|u_0\|_{H_k^1(B_R)} \right), \quad (4.12)$$

and, if $kR_0 \gtrsim 1$,

$$\|u_1^\varepsilon\|_{H_k^{1/2}(\Gamma)} \lesssim (1 + (k\varepsilon)^{-1/2}) \left(k \|u_0\|_{H^1(D_{\text{in}})} + \|u_0\|_{H^2(D_{\text{in}})} \right). \quad (4.13)$$

Proof. By the definitions of $\hat{\mathbf{C}}$ (4.5) and of u_1 (4.9),

$$\frac{\partial u_1}{\partial y_\ell} = -\frac{\partial \hat{\chi}_j}{\partial y_\ell} \frac{\partial u_0}{\partial x_j} = \left(-\hat{\mathbf{C}} \nabla u_0 \right)_\ell,$$

which is (4.10). By the definition of u_1 (4.9) and the bound on $\widehat{\chi}_j$ (4.4),

$$\|u_1^\varepsilon\|_{L^2(D_{\text{in}})} \leq \|\widehat{\chi}_j\|_{L^\infty(Y)} \left\| \frac{\partial u_0}{\partial x_j} \right\|_{L^2(D_{\text{in}})} \lesssim |u_0|_{H^1(D_{\text{in}})}$$

and

$$\|(\nabla_{\mathbf{x}} u_1)^\varepsilon\|_{L^2(D_{\text{in}})} \leq \|\widehat{\chi}_j\|_{L^\infty(Y)} \left\| \frac{\partial u_0}{\partial x_j} \right\|_{H^1(D_{\text{in}})} \lesssim |u_0|_{H^2(D_{\text{in}})},$$

and then the bound (4.11) follows.

By (4.1) and (4.10),

$$\nabla(u_1^\varepsilon) = (\nabla_{\mathbf{x}} u_1)^\varepsilon + \frac{1}{\varepsilon} (\nabla_{\mathbf{y}} u_1)^\varepsilon = (\nabla_{\mathbf{x}} u_1)^\varepsilon - \frac{1}{\varepsilon} \widehat{\mathbf{C}}^\varepsilon \nabla u_0.$$

Therefore

$$\|\nabla(u_1^\varepsilon)\|_{L^2(D_{\text{in}})} \lesssim |u_0|_{H^2(D_{\text{in}})} + \varepsilon^{-1} |u_0|_{H^1(D_{\text{in}})} \lesssim (k\varepsilon)^{-1} \left(|u_0|_{H^2(D_{\text{in}})} + k \|u_0\|_{H_k^1(B_R)} \right).$$

Then, the bound (4.12) follows from combining this with the bound on $\|u_1^\varepsilon\|_{L^2(D_{\text{in}})}$ in (4.11).

Let the operator $T : \mathbf{L}^2(\Gamma) \rightarrow L^2(\Gamma)$ be defined by $T\mathbf{v} := -\widehat{\chi}_j^\varepsilon \mathbf{v}_j$ for all $\mathbf{v} \in \mathbf{L}^2(\Gamma)$; then

$$\|T\mathbf{v}\|_{L^2(\Gamma)} \lesssim \|\mathbf{v}\|_{\mathbf{L}^2(\Gamma)} \quad \text{for all } \mathbf{v} \in \mathbf{L}^2(\Gamma).$$

In addition, $T : \mathbf{H}^1(\Gamma) \rightarrow H^1(\Gamma)$ with

$$\|T\mathbf{v}\|_{H^1(\Gamma)} \lesssim \varepsilon^{-1} \|\mathbf{v}\|_{L^2(\Gamma)} + \|\mathbf{v}\|_{\mathbf{H}^1(\Gamma)} \quad \text{for all } \mathbf{v} \in \mathbf{H}^1(\Gamma).$$

By interpolation (see, e.g., [53, Appendix B]), T then maps $\mathbf{H}^{1/2}(\Gamma) \rightarrow H^{1/2}(\Gamma)$ with

$$\|T\mathbf{v}\|_{H^{1/2}(\Gamma)} \lesssim \varepsilon^{-1/2} \|\mathbf{v}\|_{L^2(\Gamma)} + |\mathbf{v}|_{\mathbf{H}^{1/2}(\Gamma)}.$$

We now observe that $u_1^\varepsilon|_\Gamma = T((\nabla u_0)|_\Gamma)$, so that

$$\|u_1^\varepsilon\|_{H^{1/2}(\Gamma)} \lesssim \varepsilon^{-1/2} \|\nabla u_0\|_{L^2(\Gamma)} + |\nabla u_0|_{\mathbf{H}^{1/2}(\Gamma)}. \quad (4.14)$$

By Lemma 2.11,

$$\|\nabla u_0\|_{\mathbf{H}^{1/2}(\Gamma)} \lesssim \|u_0\|_{H^2(D_{\text{in}})}, \quad (4.15)$$

and, by (2.23),

$$\|\nabla u_0\|_{L^2(\Gamma)}^2 \lesssim \frac{1}{R_0} \|u_0\|_{H^1(D_{\text{in}})}^2 + \|u_0\|_{H^1(D_{\text{in}})} \|u_0\|_{H^2(D_{\text{in}})} \quad (4.16)$$

$$\lesssim \frac{1}{k} \left(1 + \frac{1}{kR_0} \right) \left(k^2 \|u_0\|_{H^1(D_{\text{in}})}^2 + \|u_0\|_{H^2(D_{\text{in}})}^2 \right). \quad (4.17)$$

Using (4.15) and (4.16) in (4.14), and recalling the assumption that $kR_0 \gtrsim 1$, the result (4.13) follows. \blacksquare

4.2.2 The second-order corrector

The second-order corrector arises since \widehat{n}^ε varies (in addition to $\widehat{\mathbf{A}}^\varepsilon$ varying); that corrector is formally defined by

$$u_2(\mathbf{x}, \mathbf{y}) := k^2 \widehat{\mu}(\mathbf{y}) u_0(\mathbf{x}),$$

where $\widehat{\mu}$ is the unique element of $H_{\sharp}^1(Y)$ such that

$$-\nabla_{\mathbf{y}} \cdot \left(\widehat{\mathbf{A}} \nabla_{\mathbf{y}} \widehat{\mu} \right) = \widehat{n} - n^H. \quad (4.18)$$

By Lemma A.2, $\widehat{\mu} \in C^1(\mathcal{P})$ with

$$\|\widehat{\mu}\|_{W^{1,\infty}(\mathcal{P})} \lesssim 1.$$

We can actually bypass referring explicitly to this second-order corrector in the rest of proof of Theorem 1.14, and directly establish the following result (where, both here and in the rest of the paper, $(\cdot, \cdot)_{D_{\text{in}}}$ denotes the $L^2(D_{\text{in}})$ inner product, and similarly for inner products over other domains).

Lemma 4.4 (Bound on the contribution from the second-order corrector)

$$k^2 |((\widehat{n}^\varepsilon - n^H)u_0, v)_{D_{\text{in}}}| \lesssim \varepsilon \left(k \|u_0\|_{H_k^1(D_{\text{in}})} \right) \|v\|_{H_k^1(D_{\text{in}})} \quad \text{for all } v \in H^1(D_{\text{in}}). \quad (4.19)$$

Proof. Since both $\widehat{\mathbf{A}}$ and $\widehat{\mu}$ are independent of \mathbf{x} , by (4.18),

$$-\nabla \cdot \left[(\widehat{\mathbf{A}} \nabla_{\mathbf{y}} \widehat{\mu})^\varepsilon \right] = -\frac{1}{\varepsilon} \left[\nabla_{\mathbf{y}} \cdot (\widehat{\mathbf{A}} \nabla_{\mathbf{y}} \widehat{\mu}) \right]^\varepsilon = \frac{1}{\varepsilon} (\widehat{n}^\varepsilon - n^H) \in L^\infty(D_{\text{in}}).$$

Therefore,

$$\begin{aligned} -\nabla \cdot (u_0 (\widehat{\mathbf{A}} \nabla_{\mathbf{y}} \widehat{\mu})^\varepsilon) &= -u_0 \nabla \cdot (\widehat{\mathbf{A}} \nabla_{\mathbf{y}} \widehat{\mu})^\varepsilon - \nabla u_0 \cdot (\widehat{\mathbf{A}} \nabla_{\mathbf{y}} \widehat{\mu})^\varepsilon \\ &= \frac{1}{\varepsilon} (\widehat{n}^\varepsilon - n^H) u_0 - \nabla u_0 \cdot (\widehat{\mathbf{A}} \nabla_{\mathbf{y}} \widehat{\mu})^\varepsilon. \end{aligned}$$

By Condition 1.10 and Lemma A.2, $\widehat{\mathbf{A}} \in C^0(\mathcal{S})$ and $\widehat{\mu} \in C^1(\mathcal{S})$. Therefore, the function $(\widehat{\mathbf{A}} \nabla_{\mathbf{y}} \widehat{\mu})^\varepsilon$ is piecewise continuous on a partition of D_{in} consisting of a finite number of open sets, so that its trace on ∂D_{in} is well-defined. In addition,

$$\|(\widehat{\mathbf{A}} \nabla_{\mathbf{y}} \widehat{\mu})^\varepsilon\|_{L^\infty(D_{\text{in}})} \leq \|\widehat{\mathbf{A}}\|_{L^\infty(Y)} \|\nabla_{\mathbf{y}} \widehat{\mu}\|_{L^\infty(Y)} \lesssim 1$$

and similarly

$$\|(\widehat{\mathbf{A}} \nabla_{\mathbf{y}} \widehat{\mu})^\varepsilon\|_{L^\infty(\partial D_{\text{in}})} \lesssim 1.$$

By Green's first identity in D_{in} ,

$$\begin{aligned} \int_{D_{\text{in}}} u_0 (\widehat{\mathbf{A}} \nabla_{\mathbf{y}} \widehat{\mu})^\varepsilon \cdot \nabla v &= \int_{\Gamma} u_0 (\widehat{\mathbf{A}} \nabla_{\mathbf{y}} \widehat{\mu})^\varepsilon \cdot \boldsymbol{\nu} v - \int_{D_{\text{in}}} \nabla \cdot (u_0 \widehat{\mathbf{A}} \nabla_{\mathbf{y}} \widehat{\mu})^\varepsilon v \\ &= \int_{\Gamma} u_0 (\widehat{\mathbf{A}} \nabla_{\mathbf{y}} \widehat{\mu})^\varepsilon \cdot \boldsymbol{\nu} v + \frac{1}{\varepsilon} \int_{D_{\text{in}}} (\widehat{n}^\varepsilon - n^H) u_0 v - \int_{D_{\text{in}}} \nabla u_0 \cdot (\widehat{\mathbf{A}} \nabla_{\mathbf{y}} \widehat{\mu})^\varepsilon v, \end{aligned}$$

and thus

$$\frac{1}{\varepsilon} \int_{D_{\text{in}}} (\widehat{n}^\varepsilon - n^H) u_0 v = \int_{\Gamma} u_0 (\widehat{\mathbf{A}} \nabla_{\mathbf{y}} \widehat{\mu})^\varepsilon \cdot \boldsymbol{\nu} v - \int_{D_{\text{in}}} \nabla u_0 \cdot (\widehat{\mathbf{A}} \nabla_{\mathbf{y}} \widehat{\mu})^\varepsilon v - \int_{D_{\text{in}}} u_0 (\widehat{\mathbf{A}} \nabla_{\mathbf{y}} \widehat{\mu})^\varepsilon \cdot \nabla v$$

To estimate each term in the right-hand side, we use the Cauchy-Schwarz inequality on each L^2 inner-product, so that

$$\begin{aligned} |((\widehat{n}^\varepsilon - n^H)u_0, v)_{D_{\text{in}}}| &\leq \varepsilon \|(\widehat{\mathbf{A}} \nabla_{\mathbf{y}} \widehat{\mu})^\varepsilon\|_{L^\infty(D_{\text{in}})} \|u_0\|_{L^2(D_{\text{in}})} \|v\|_{H^1(D_{\text{in}})} \\ &\quad + \varepsilon \|(\widehat{\mathbf{A}} \nabla_{\mathbf{y}} \widehat{\mu})^\varepsilon\|_{L^\infty(D_{\text{in}})} \|u_0\|_{H^1(D_{\text{in}})} \|v\|_{L^2(D_{\text{in}})} + \varepsilon \|(\widehat{\mathbf{A}} \nabla_{\mathbf{y}} \widehat{\mu})^\varepsilon\|_{L^\infty(\Gamma)} \|u_0\|_{L^2(\Gamma)} \|v\|_{L^2(\Gamma)} \\ &\lesssim \varepsilon \left(\|u_0\|_{L^2(D_{\text{in}})} \|v\|_{H^1(D_{\text{in}})} + \|u_0\|_{H^1(D_{\text{in}})} \|v\|_{L^2(D_{\text{in}})} + \|u_0\|_{L^2(\Gamma)} \|v\|_{L^2(\Gamma)} \right). \end{aligned}$$

Multiplying by k^2 and then using (2.24), we have

$$\begin{aligned} k^2 |((\widehat{n}^\varepsilon - n^H)u_0, v)_{D_{\text{in}}}| &\lesssim k \varepsilon \left(k \|u_0\|_{L^2(D_{\text{in}})} \|v\|_{H^1(D_{\text{in}})} + k \|u_0\|_{H^1(D_{\text{in}})} \|v\|_{L^2(D_{\text{in}})} + k \|u_0\|_{L^2(\Gamma)} \|v\|_{L^2(\Gamma)} \right) \\ &\lesssim k \varepsilon \|u_0\|_{H_k^1(D_{\text{in}})} \|v\|_{H_k^1(D_{\text{in}})}, \end{aligned}$$

which is the result (4.19). \blacksquare

4.2.3 Boundary corrector

The following lemma is proved using Theorem B.6 from Appendix B. A similar result (without the explicit k -dependence) appears in [68, Lemma 2.2] and [13, Page 2536].

Lemma 4.5 (Existence of vector potential) *There exists a vector potential $\mathbf{q} : D_{\text{in}} \times Y \rightarrow \mathbb{C}^d$ such that*

$$\nabla_{\mathbf{y}} \times \mathbf{q} = (\widehat{\mathbf{B}} - \mathbf{A}^H) \nabla u_0, \quad (4.20)$$

$$\|(\nabla_{\mathbf{x}} \times \mathbf{q})^\varepsilon\|_{L^2(D_{\text{in}})} \lesssim \|u_0\|_{H^2(D_{\text{in}})} \quad (4.21)$$

and, if $kR_0 \gtrsim 1$,

$$\|\nabla \times \mathbf{q}^\varepsilon \cdot \boldsymbol{\nu}\|_{\mathbf{H}^{-1/2}(\Gamma)} \lesssim (1 + (k\varepsilon)^{-1/2}) \left(k \|u_0\|_{H^1(D_{\text{in}})} + \|u_0\|_{H^2(D_{\text{in}})} \right). \quad (4.22)$$

Proof of Lemma 4.5 using Theorem B.6. To apply Theorem B.6, we need to show that (i) $(\widehat{\mathbf{B}} - \mathbf{A}^H) \in H^s(Y) \cap L^\infty(Y)$ for some $s > 0$, (ii) $(\widehat{\mathbf{B}} - \mathbf{A}^H)$ does not depend on y_d , and (iii) $\nabla_{\mathbf{y}} \cdot ((\widehat{\mathbf{B}} - \mathbf{A}^H)\mathbf{w}) = 0$ for all $\mathbf{w} \in \mathbb{C}^d$ independent of \mathbf{y} .

Regarding (i): this is shown under (4.7). Regarding (ii): \mathbf{A}^H is constant, and therefore independent of y_d . $\widehat{\mathbf{A}}$ is independent of y_d by Condition 1.10, therefore so are the $\widehat{\chi}_j$ by Lemma A.2, therefore so is $\widehat{\mathbf{C}}$ by (4.5), and therefore so is $\widehat{\mathbf{B}}$ by (4.6). Regarding (iii): by the definition of $\widehat{\mathbf{B}}$ (4.6), for $\mathbf{w} \in \mathbb{C}^d$ independent of \mathbf{y} ,

$$\nabla_{\mathbf{y}} \cdot ((\widehat{\mathbf{B}} - \mathbf{A}^H)\mathbf{w}) = \nabla_{\mathbf{y}} \cdot (\widehat{\mathbf{B}}\mathbf{w}) = \nabla_{\mathbf{y}} \cdot (\widehat{\mathbf{A}}\mathbf{w}) - \nabla_{\mathbf{y}} \cdot (\widehat{\mathbf{A}}\widehat{\mathbf{C}}\mathbf{w}),$$

which equals zero by (4.3) and the definition of $\widehat{\mathbf{C}}$ (4.5). \blacksquare

Let $b^\varepsilon(\cdot, \cdot)$ denote the sesquilinear form $b(\cdot, \cdot)$ (1.6) with coefficients \mathbf{A}_ε and n_ε . Let $b_{\text{out}}(\cdot, \cdot)$ denote the sesquilinear form $b(\cdot, \cdot)$ with integration over B_R replaced by integration over D_{out} (and recall that, in D_{out} , $\mathbf{A}_\varepsilon = \mathbf{I}$ and $n_\varepsilon = 1$ by (1.16)).

We now define the boundary corrector θ_ε as the unique element of $H^1(B_R)$ such that

$$b^\varepsilon(\theta_\varepsilon, v) = b_{\text{out}}(E(u_1^\varepsilon), v) + (\nabla \times \mathbf{q}^\varepsilon \cdot \boldsymbol{\nu}, v)_\Gamma \quad \text{for all } v \in H^1(B_R), \quad (4.23)$$

where E is the extension operator in Lemma 2.11. Since the right-hand side of (4.23) is an element of $(H^1(B_R))'$, the problem (4.23) is indeed well-posed; the rationale for choosing this particular right-hand side becomes clear in the proof of Lemma 4.7 below.

Lemma 4.6 (Bound on the norm of the boundary corrector) *If $\theta_\varepsilon \in H^1(B_R)$ is the boundary corrector defined by (4.23) and $kR_0 \gtrsim 1$, then*

$$\begin{aligned} \|\theta_\varepsilon\|_{H_k^1(B_R)} &\lesssim C_{\text{layer}}(kR, kR_0, \widehat{n}_{\min}) (\|u_1^\varepsilon\|_{H_k^{1/2}(\Gamma)} + \|\nabla \times \mathbf{q}^\varepsilon \cdot \boldsymbol{\nu}\|_{H^{-1/2}(\Gamma)}) \\ &\lesssim C_{\text{layer}}(kR, kR_0, \widehat{n}_{\min}) (1 + (k\varepsilon)^{-1/2}) (k\|u_0\|_{H^1(D_{\text{in}})} + \|u_0\|_{H^2(D_{\text{in}})}). \end{aligned} \quad (4.24)$$

Proof. Let $\psi \in (H^1(B_R))'$ be defined such that

$$\langle \psi, v \rangle = b^\varepsilon(\theta_\varepsilon, v) \quad \text{for all } v \in H^1(B_R).$$

By (1.17),

$$\|\theta_\varepsilon\|_{H_k^1(B_R)} \leq C_{\text{layer}}(kR, kR_0, \widehat{n}_{\min}) \|\psi\|_{(H_k^1(B_R))'},$$

so that it remains to estimate the dual norm of ψ . By the definition of θ_ε (4.23), continuity of b_{out} , and Lemma 2.11, for all $v \in H^1(B_R)$,

$$\begin{aligned} |\langle \psi, v \rangle| &\leq |b_{\text{out}}(E(u_1^\varepsilon), v)| + |(\nabla \times \mathbf{q}^\varepsilon \cdot \boldsymbol{\nu}, v)_\Gamma| \\ &\lesssim \|E(u_1^\varepsilon)\|_{H_k^1(D_{\text{out}})} \|v\|_{H_k^1(D_{\text{out}})} + \|(\nabla \times \mathbf{q}^\varepsilon) \cdot \boldsymbol{\nu}\|_{H^{-1/2}(\Gamma)} \|v\|_{H^{1/2}(\Gamma)} \\ &\lesssim (\|u_1^\varepsilon\|_{H_k^{1/2}(\Gamma)} + \|(\nabla \times \mathbf{q}^\varepsilon) \cdot \boldsymbol{\nu}\|_{H^{-1/2}(\Gamma)}) \|v\|_{H_k^1(B_R)}, \end{aligned}$$

and the inequality (4.24) follows. The second inequality then follows from using the bounds (4.13) and (4.22). \blacksquare

4.3 Proof of Theorem 1.14

The proof relies on the following error estimate involving the boundary corrector θ_ε , whose proof is postponed until Section 4.4.

Lemma 4.7 (Error estimate with a boundary corrector) *Let $u_{1,\varepsilon} \in H^1(B_R)$ be defined by*

$$u_{1,\varepsilon} := \begin{cases} u_1^\varepsilon & \text{in } D_{\text{in}}, \\ E(u_1^\varepsilon) & \text{in } D_{\text{out}}. \end{cases} \quad (4.25)$$

where the extension operator E is as in Lemma 2.12. Then,

$$\|u_\varepsilon - (u_0 + \varepsilon(u_{1,\varepsilon} - \theta_\varepsilon))\|_{H_k^1(B_R)} \lesssim C_{\text{layer}}(kR, kR_0, \widehat{n}_{\min}) \varepsilon \left(\|u_0\|_{H^2(B_R)} + k\|u_0\|_{H_k^1(B_R)} \right). \quad (4.26)$$

Remark 4.8 (Difference between our first-order and boundary correctors and those in [13] .) In [13], the first-order corrector is defined by u_1^ε in D_{in} and zero in D_{out} , and is therefore not in $H^1(B_R)$ because of the jump on Γ . Analogously, the boundary corrector θ_ε defined by [13, Equation 18] has a jump on Γ and is not in $H^1(B_R)$. In contrast, both our first-order corrector $u_{1,\varepsilon}$ (4.25) and our boundary corrector θ_ε (4.23) are defined so that they are in $H^1(B_R)$.

Proof of Theorem 1.14 using Lemma 4.7. By (in this order) the triangle inequality, the definition of $u_{1,\varepsilon}$ (4.25), the triangle inequality again and the bound (2.25), the bounds (4.26) and (4.24), and the fact that $C_{\text{layer}}(kR, kR_0, \widehat{n}_{\min}) \gtrsim 1$,

$$\begin{aligned} & k \|u_\varepsilon - u_0 - \varepsilon u_1^\varepsilon\|_{H_k^1(D_{\text{in}})} + k \|u_\varepsilon - u_0\|_{H_k^1(D_{\text{out}})} \\ & \leq k \|u_\varepsilon - u_0 - \varepsilon u_{1,\varepsilon}\|_{H_k^1(B_R)} + k\varepsilon \|E(u_1^\varepsilon)\|_{H_k^1(B_R)}, \\ & \lesssim k \|u_\varepsilon - u_0 - \varepsilon(u_{1,\varepsilon} - \theta_\varepsilon)\|_{H_k^1(B_R)} + k\varepsilon \|\theta_\varepsilon\|_{H_k^1(B_R)} + k\varepsilon \|u_1^\varepsilon\|_{H_k^{1/2}(\Gamma)}, \\ & \lesssim C_{\text{layer}}(kR, kR_0, \widehat{n}_{\min}) k\varepsilon \left(\|u_0\|_{H^2(B_R)} + k \|u_0\|_{H_k^1(B_R)} \right) \\ & \quad + C_{\text{layer}}(kR, kR_0, \widehat{n}_{\min}) k\varepsilon \left(\|u_1^\varepsilon\|_{H_k^{1/2}(\Gamma)} + \|\nabla \times \mathbf{q}^\varepsilon \cdot \boldsymbol{\nu}\|_{H^{-1/2}(\Gamma)} \right). \end{aligned}$$

The bound (1.20) then follows from the bounds (4.22) and (4.13); the bound (1.21) then follows from the bound (4.8). \blacksquare

4.4 Proof of Lemma 4.7

Since

$$\|\phi\|_{H_k^1(B_R)} = \sup_{\substack{\psi \in (H_k^1(B_R))' \\ \psi \neq 0}} \frac{|\langle \phi, \psi \rangle|}{\|\psi\|_{(H_k^1(B_R))'}}$$

(see, e.g., [53, Page 76 and Theorem 3.30]), if we can show that

$$|(u_\varepsilon - (u_0 + \varepsilon(u_{1,\varepsilon} - \theta_\varepsilon)), \psi)_{B_R}| \lesssim \mathcal{M} \|\psi\|_{(H_k^1(B_R))'} \quad (4.27)$$

for all $\psi \in L^2(B_R)$, with

$$\mathcal{M} := C_{\text{layer}}(kR, kR_0, \widehat{n}_{\min}) \varepsilon \left(\|u_0\|_{H^2(B_R)} + k \|u_0\|_{H_k^1(B_R)} \right),$$

then the bound (4.26) follows since $L^2(B_R)$ is dense in $(H^1(B_R))'$. With ψ an arbitrary element of $L^2(B_R)$, let $W_\varepsilon \in H^1(B_R)$ be the solution of the adjoint problem

$$b^\varepsilon(v, W_\varepsilon) = (v, \psi)_{B_R} \quad \text{for all } v \in H^1(B_R). \quad (4.28)$$

We now claim that

$$b^\varepsilon(\overline{W_\varepsilon}, v) = (\overline{\psi}, v)_{B_R} \quad \text{for all } v \in H^1(B_R);$$

indeed, this follows from that fact that $b^\varepsilon(\cdot, \cdot)$ is the sesquilinear form $b(\cdot, \cdot)$ (1.6) with coefficients \mathbf{A}_ε and n_ε , and the fact that $\langle \text{DtN}_k \phi, \overline{\psi} \rangle_\Gamma = \langle \text{DtN}_k \psi, \overline{\phi} \rangle_\Gamma$ (from Green's second identity and the Sommerfeld radiation condition (1.1); see, e.g., [82, Lemma 6.13]). Then, by (1.17),

$$\|W_\varepsilon\|_{H_k^1(B_R)} \leq C_{\text{layer}}(kR, kR_0, \widehat{n}_{\min}) \|\psi\|_{(H_k^1(B_R))'}. \quad (4.29)$$

The following lemmas involve different components of the inner product on the left-hand side of (4.27); we highlight that the first lemma is the point where the existence of the vector-potential (4.20) is used.

Lemma 4.9 (The terms in the inner product (4.27) involving $u_\varepsilon - u_0$)

$$\begin{aligned} (u_\varepsilon - u_0, \psi)_{B_R} &= -k^2 ((n^H - \widehat{n}^\varepsilon)u_0, W_\varepsilon)_{D_{\text{in}}} - ((\widehat{\mathbf{A}}\widehat{\mathbf{C}})^\varepsilon \nabla u_0, \nabla W_\varepsilon)_{D_{\text{in}}} \\ & \quad + \varepsilon ((\nabla_{\mathbf{x}} \times \mathbf{q})^\varepsilon, \nabla W_\varepsilon)_{D_{\text{in}}} - \varepsilon ((\nabla \times \mathbf{q}^\varepsilon) \cdot \boldsymbol{\nu}, W_\varepsilon)_\Gamma \end{aligned} \quad (4.30)$$

Proof. By the definition of W_ε (4.28),

$$(u_\varepsilon - u_0, \psi)_{B_R} = b^\varepsilon(u_\varepsilon, W_\varepsilon) - b^\varepsilon(u_0, W_\varepsilon).$$

Since u_ε and u_0 are the solutions to the oscillatory and homogenized problems, respectively,

$$b^\varepsilon(u_\varepsilon, v) = (f, v)_{B_R} = b^H(u_0, v) \quad \text{for all } v \in H^1(B_R),$$

where $b^H(\cdot, \cdot)$ denotes the sesquilinear form $b(\cdot, \cdot)$ (1.6) with coefficients \mathbf{A}^H and n^H in D_{in} and $\mathbf{A} = \mathbf{I}$ and $n = 1$ in D_{out} . Therefore, since b^H and b^ε are identical on D_{out} ,

$$(u_\varepsilon - u_0, \psi) = b^H(u_0, W_\varepsilon) - b^\varepsilon(u_0, W_\varepsilon) = ((\mathbf{A}^H - \widehat{\mathbf{A}}^\varepsilon) \nabla u_0, \nabla W_\varepsilon)_{D_{\text{in}}} - k^2((n^H - \widehat{n}^\varepsilon) u_0, W_\varepsilon)_{D_{\text{in}}}. \quad (4.31)$$

Lemma 4.4 bounds the second term on the right-hand side; we therefore focus on the first term. Since $\widehat{\mathbf{B}} := \widehat{\mathbf{A}}(\mathbf{I} - \widehat{\mathbf{C}})$, $(\mathbf{A}^H - \widehat{\mathbf{A}}^\varepsilon) + (\widehat{\mathbf{A}}\widehat{\mathbf{C}})^\varepsilon = \mathbf{A}^H - \widehat{\mathbf{B}}^\varepsilon$, and thus

$$\begin{aligned} ((\mathbf{A}^H - \widehat{\mathbf{A}}^\varepsilon) \nabla u_0, \nabla W_\varepsilon)_{D_{\text{in}}} + ((\widehat{\mathbf{A}}\widehat{\mathbf{C}})^\varepsilon \nabla u_0, \nabla W_\varepsilon)_{D_{\text{in}}} &= ((\mathbf{A}^H - \widehat{\mathbf{B}}^\varepsilon) \nabla u_0, \nabla W_\varepsilon)_{D_{\text{in}}} \\ &= ((\mathbf{A}^H - \widehat{\mathbf{B}}) \nabla u_0)^\varepsilon, \nabla W_\varepsilon)_{D_{\text{in}}}. \end{aligned}$$

By the definition of \mathbf{q} (4.20), $((\mathbf{A}^H - \widehat{\mathbf{B}}) \nabla u_0)^\varepsilon = -(\nabla_{\mathbf{y}} \times \mathbf{q})^\varepsilon$, and thus

$$((\mathbf{A}^H - \widehat{\mathbf{A}}^\varepsilon) \nabla u_0, \nabla W_\varepsilon)_{D_{\text{in}}} = -((\widehat{\mathbf{A}}\widehat{\mathbf{C}})^\varepsilon \nabla u_0, \nabla W_\varepsilon)_{D_{\text{in}}} - ((\nabla_{\mathbf{y}} \times \mathbf{q})^\varepsilon, \nabla W_\varepsilon)_{D_{\text{in}}};$$

combining this with (4.31) yields

$$(u_\varepsilon - u_0, \psi)_{B_R} = -k^2((n^H - \widehat{n}^\varepsilon) u_0, W_\varepsilon)_{D_{\text{in}}} - ((\widehat{\mathbf{A}}\widehat{\mathbf{C}})^\varepsilon \nabla u_0, \nabla W_\varepsilon)_{D_{\text{in}}} - ((\nabla_{\mathbf{y}} \times \mathbf{q})^\varepsilon, \nabla W_\varepsilon)_{D_{\text{in}}}. \quad (4.32)$$

We now focus on the term involving $(\nabla_{\mathbf{y}} \times \mathbf{q})^\varepsilon$. By (4.1),

$$(\nabla_{\mathbf{y}} \times \mathbf{q})^\varepsilon = \varepsilon(\nabla \times \mathbf{q}^\varepsilon - (\nabla_{\mathbf{x}} \times \mathbf{q})^\varepsilon)$$

and thus, by the divergence theorem,

$$\begin{aligned} ((\nabla_{\mathbf{y}} \times \mathbf{q})^\varepsilon, \nabla W_\varepsilon)_{D_{\text{in}}} &= \varepsilon(\nabla \times \mathbf{q}^\varepsilon, \nabla W_\varepsilon)_{D_{\text{in}}} - \varepsilon((\nabla_{\mathbf{x}} \times \mathbf{q})^\varepsilon, \nabla W_\varepsilon)_{D_{\text{in}}} \\ &= \varepsilon((\nabla \times \mathbf{q}^\varepsilon) \cdot \boldsymbol{\nu}, W_\varepsilon)_\Gamma - \varepsilon((\nabla_{\mathbf{x}} \times \mathbf{q})^\varepsilon, \nabla W_\varepsilon)_{D_{\text{in}}}, \end{aligned}$$

where we have crucially used that $\nabla \cdot \nabla \times \mathbf{q}^\varepsilon = 0$; the result (4.30) then follows by combining this last equality with (4.32). \blacksquare

Lemma 4.10 (The term in the inner product (4.27) involving $\varepsilon u_{1,\varepsilon}$)

$$\begin{aligned} -(\varepsilon u_{1,\varepsilon}, \psi)_{B_R} &= -\varepsilon b_{\text{out}}(E(u_1^\varepsilon), W_\varepsilon) + ((\widehat{\mathbf{A}}\widehat{\mathbf{C}})^\varepsilon \nabla u_0, \nabla W_\varepsilon)_{D_{\text{in}}} \\ &\quad + k^2 \varepsilon (\widehat{n}^\varepsilon u_1^\varepsilon, W_\varepsilon)_{D_{\text{in}}} - \varepsilon ((\widehat{\mathbf{A}} \nabla_{\mathbf{x}} u_1)^\varepsilon, \nabla W_\varepsilon)_{D_{\text{in}}}. \end{aligned} \quad (4.33)$$

Proof. By the definitions of W_ε (4.28) and $u_{1,\varepsilon}$ (4.25),

$$-(\varepsilon u_{1,\varepsilon}, \psi)_{B_R} = -\varepsilon b^\varepsilon(u_{1,\varepsilon}, W_\varepsilon) = -\varepsilon b_{\text{out}}(E(u_1^\varepsilon), W_\varepsilon) - \varepsilon b_{\text{in}}^\varepsilon(u_1^\varepsilon, W_\varepsilon),$$

where $b_{\text{in}}^\varepsilon(\cdot, \cdot) := b^\varepsilon(\cdot, \cdot) - b_{\text{out}}(\cdot, \cdot)$. By this definition,

$$-\varepsilon b_{\text{in}}^\varepsilon(u_1^\varepsilon, W_\varepsilon) = -\varepsilon (\widehat{\mathbf{A}}^\varepsilon \nabla u_1^\varepsilon, \nabla W_\varepsilon)_{D_{\text{in}}} + \varepsilon k^2 (\widehat{n}^\varepsilon u_1^\varepsilon, W_\varepsilon)_{D_{\text{in}}}.$$

and so to prove the result (4.33), we only need to prove that

$$-\varepsilon (\widehat{\mathbf{A}}^\varepsilon \nabla u_1^\varepsilon, \nabla W_\varepsilon)_{D_{\text{in}}} = ((\widehat{\mathbf{A}}\widehat{\mathbf{C}})^\varepsilon \nabla u_0, \nabla W_\varepsilon)_{D_{\text{in}}} - \varepsilon ((\widehat{\mathbf{A}} \nabla_{\mathbf{x}} u_1)^\varepsilon, \nabla W_\varepsilon)_{D_{\text{in}}}. \quad (4.34)$$

By (4.1) and (4.10),

$$\nabla(u_1^\varepsilon) = (\nabla_{\mathbf{x}}u_1)^\varepsilon + \frac{1}{\varepsilon}(\nabla_{\mathbf{y}}u_1)^\varepsilon = (\nabla_{\mathbf{x}}u_1)^\varepsilon - \frac{1}{\varepsilon}\widehat{\mathbf{C}}^\varepsilon\nabla u_0;$$

therefore,

$$\widehat{\mathbf{A}}^\varepsilon\nabla(u_1^\varepsilon) = (\widehat{\mathbf{A}}\nabla_{\mathbf{x}}u_1)^\varepsilon - \frac{1}{\varepsilon}(\widehat{\mathbf{A}}\widehat{\mathbf{C}})^\varepsilon\nabla u_0,$$

and (4.34) (and hence (4.33)) follows. \blacksquare

Proof of Lemma 4.7. By the discussion at the start of the subsection, it is sufficient to prove (4.27). By the definitions of W_ε (4.28) and θ_ε (4.23)

$$\varepsilon(\theta_\varepsilon, \psi) = \varepsilon b^\varepsilon(\theta_\varepsilon, W_\varepsilon) = \varepsilon b_{\text{out}}(E(u_1^\varepsilon), W_\varepsilon) + \varepsilon((\nabla \times \mathbf{q}^\varepsilon) \cdot \boldsymbol{\nu}, W_\varepsilon)_\Gamma. \quad (4.35)$$

We now rewrite

$$(u_\varepsilon - (u_0 + \varepsilon(u_{1,\varepsilon} - \theta_\varepsilon)), \psi)_{B_R}$$

using (4.30), (4.33), and (4.35), to obtain that

$$\begin{aligned} & (u_\varepsilon - (u_0 + \varepsilon(u_{1,\varepsilon} - \theta_\varepsilon)), \psi)_{B_R} \\ &= -k^2((n^H - \widehat{n}^\varepsilon)u_0, W_\varepsilon)_{D_{\text{in}}} - ((\widehat{\mathbf{A}}\widehat{\mathbf{C}})^\varepsilon\nabla u_0, \nabla W_\varepsilon)_{D_{\text{in}}} + \varepsilon((\nabla_{\mathbf{x}} \times \mathbf{q})^\varepsilon, \nabla W_\varepsilon)_{D_{\text{in}}} \\ & \quad - \varepsilon((\nabla \times \mathbf{q}^\varepsilon) \cdot \boldsymbol{\nu}, W_\varepsilon)_\Gamma - \varepsilon b_{\text{out}}(E(u_1^\varepsilon), W_\varepsilon) + ((\widehat{\mathbf{A}}\widehat{\mathbf{C}})^\varepsilon\nabla u_0, \nabla W_\varepsilon)_{D_{\text{in}}} + k^2\varepsilon(\widehat{n}^\varepsilon u_1^\varepsilon, W_\varepsilon)_{D_{\text{in}}} \\ & \quad - \varepsilon((\widehat{\mathbf{A}}\nabla_{\mathbf{x}}u_1)^\varepsilon, \nabla W_\varepsilon)_{D_{\text{in}}} + \varepsilon b_{\text{out}}(E(u_1^\varepsilon), W_\varepsilon) + \varepsilon((\nabla \times \mathbf{q}^\varepsilon) \cdot \boldsymbol{\nu}, W_\varepsilon)_\Gamma \\ &= -k^2((n^H - \widehat{n}^\varepsilon)u_0, W_\varepsilon)_{D_{\text{in}}} + \varepsilon((\nabla_{\mathbf{x}} \times \mathbf{q})^\varepsilon, \nabla W_\varepsilon)_{D_{\text{in}}} - k^2\varepsilon(\widehat{n}^\varepsilon u_1^\varepsilon, W_\varepsilon)_{D_{\text{in}}} + \varepsilon((\widehat{\mathbf{A}}\nabla_{\mathbf{x}}u_1)^\varepsilon, \nabla W_\varepsilon)_{D_{\text{in}}}. \end{aligned}$$

In particular, we see that the terms $\varepsilon((\nabla \times \mathbf{q}^\varepsilon) \cdot \boldsymbol{\nu}, W_\varepsilon)_\Gamma$ and $\varepsilon b_{\text{out}}(E(u_1^\varepsilon), W_\varepsilon)$, present in the right-hand sides of (4.30) and (4.33), respectively, have been removed thanks to the definition of the boundary corrector θ_ε (4.23) and its consequence (4.35).

We now bound each of the four terms on the right-hand side. By (4.19),

$$k^2|((n^H - \widehat{n}^\varepsilon)u_0, W_\varepsilon)_{D_{\text{in}}}| \lesssim k\varepsilon \|u_0\|_{H_k^1(B_R)} \|W_\varepsilon\|_{H_k^1(D_{\text{in}})},$$

and by (4.21),

$$\varepsilon|((\nabla_{\mathbf{x}} \times \mathbf{q})^\varepsilon, \nabla W_\varepsilon)_{D_{\text{in}}}| \lesssim \varepsilon \|u_0\|_{H^2(B_R)} \|W_\varepsilon\|_{H_k^1(D_{\text{in}})}.$$

Using the fact that $\|\widehat{n}^\varepsilon\|_{L^\infty(Y)} \lesssim 1$ (by Definition 1.9), the Cauchy–Schwarz inequality, and the bound (4.11), we have

$$k^2\varepsilon|(\widehat{n}^\varepsilon u_1^\varepsilon, W_\varepsilon)_{D_{\text{in}}}| \lesssim \varepsilon(k\|u_1^\varepsilon\|_{L^2(D_{\text{in}})}) (k\|W_\varepsilon\|_{L^2(D_{\text{in}})}) \lesssim \varepsilon(\|u_0\|_{H^2(B_R)} + k\|u_0\|_{H_k^1(B_R)}) \|W_\varepsilon\|_{H_k^1(D_{\text{in}})}.$$

Similarly, using that $\|\widehat{\mathbf{A}}\|_{L^\infty(Y)} \lesssim 1$ (again by Definition 1.9), and the bound (4.11), we have

$$\begin{aligned} \varepsilon|((\widehat{\mathbf{A}}\nabla_{\mathbf{x}}u_1)^\varepsilon, \nabla W_\varepsilon)_{D_{\text{in}}}| &\leq \varepsilon\|\widehat{\mathbf{A}}^\varepsilon\|_{L^\infty(D_{\text{in}})}\|(\nabla_{\mathbf{x}}u_1)^\varepsilon\|_{L^2(D_{\text{in}})}\|W_\varepsilon\|_{H^1(D_{\text{in}})} \\ &\lesssim \varepsilon(\|u_0\|_{H^2(B_R)} + k\|u_0\|_{H_k^1(B_R)})\|W_\varepsilon\|_{H_k^1(D_{\text{in}})}. \end{aligned}$$

Combining these bounds, we have

$$|(u_\varepsilon - (u_0 + \varepsilon(u_{1,\varepsilon} - \theta_\varepsilon)), \psi)_{B_R}| \lesssim \varepsilon(\|u_0\|_{H^2(B_R)} + k\|u_0\|_{H_k^1(B_R)})\|W_\varepsilon\|_{1,k,D_{\text{in}}}$$

and then using (4.29) we obtain (4.27). \blacksquare

4.5 Proof of Corollary 1.15

By Lemma 2.9, it is sufficient to prove that, if $F(v) = \int_{B_R} f \bar{v}$, then

$$\|u_\varepsilon\|_{H_k^1(B_R)} \lesssim \frac{C_{\text{sol},H}}{k} \left[1 + C_{\text{layer}}(kR, kR_0, n_{\min}) \left((k\varepsilon)^{1/2} + k\varepsilon \right) \right] \|f\|_{L^2(B_R)}. \quad (4.36)$$

By the triangle inequality, Theorem 1.14, and the definition of $C_{\text{sol},H}$ (1.11),

$$\begin{aligned} \|u_\varepsilon\|_{H_k^1(B_R)} &\leq \|u_\varepsilon - u_0\|_{H_k^1(B_R)} + \|u_0\|_{H_k^1(B_R)}, \\ &\leq \frac{C_{\text{sol},H}}{k} C_4 C_{\text{layer}}(kR, kR_0, n_{\min}) \left((k\varepsilon)^{1/2} + k\varepsilon \right) \|f\|_{L^2(B_R)} + \varepsilon \|u_1^\varepsilon\|_{H_k^1(D_{\text{in}})} + \frac{C_{\text{sol},H}}{k} \|f\|_{L^2(B_R)}, \end{aligned} \quad (4.37)$$

The bound on u_1^ε (4.12) and the bound (4.8) imply that

$$\varepsilon \|u_1^\varepsilon\|_{H_k^1(D_{\text{in}})} \lesssim \varepsilon (1 + (k\varepsilon)^{-1}) \left(\|u_0\|_{H^2(D_{\text{in}})} + k \|u_0\|_{H_k^1(B_R)} \right) \lesssim \frac{C_{\text{sol},H}}{k} (1 + k\varepsilon) \|f\|_{L^2(B_R)}; \quad (4.38)$$

the bound (4.36) then follows by combining (4.37) and (4.38).

A Regularity of periodic cell problems

The goal of this section is to show that the functions $\hat{\chi}_j$ and $\hat{\mu}$ appearing in the homogenization section have the required regularity, namely that $\hat{\chi}_j \in H^{1+s}(Y) \cap C^1(\mathcal{P})$, for some $s > 0$, and that $\hat{\mu} \in C^1(\mathcal{P})$. Recall that $H_{\#}^1(Y)$ is the subspace of $H_{\text{per}}^1(Y)$ consisting of functions with zero mean.

Lemma A.1 *Given $f \in (H^1(Y))'$ with $\langle f, 1 \rangle = 0$, there exists a unique element $u \in H_{\#}^1(Y)$ such that, in a distributional sense,*

$$-\nabla \cdot (\hat{\mathbf{A}} \nabla u) = f \text{ in } Y. \quad (A.1)$$

Furthermore, if $\hat{\mathbf{A}}(\mathbf{y})$ does not depend on y_ℓ for some $\ell \in \{1, \dots, d\}$ and

$$\langle f, v \rangle = \int_Y f_0 v + \sum_{j=1}^d \int_Y f_j \frac{\partial v}{\partial y_j} \quad \text{for all } v \in H^1(Y) \quad (A.2)$$

where $f_0, f_j \in L^2(Y)$ are functions that are independent of y_ℓ , then u does not depend on y_ℓ .

Proof. Given $f \in (H^1(Y))'$, by the Poincaré-Wirtinger inequality and the Lax-Milgram lemma applied in the space $H_{\#}^1(Y)$, there exists a unique $u \in H_{\#}^1(Y)$ such that

$$(\hat{\mathbf{A}} \nabla u, \nabla v)_Y = \langle f, v \rangle \quad \text{for all } v \in H_{\#}^1(Y). \quad (A.3)$$

Now let $\phi \in C_c^\infty(Y)$, with $\phi_0 \in \mathbb{C}$ the mean value of ϕ . Then $\tilde{\phi} = \phi - \phi_0 \in H_{\#}^1(Y)$, so that, by (A.3) and the fact that $\langle f, \phi_0 \rangle = 0$,

$$(\hat{\mathbf{A}} \nabla u, \nabla \phi)_Y = (\hat{\mathbf{A}} \nabla u, \nabla \tilde{\phi})_Y = \langle f, \tilde{\phi} \rangle = \langle f, \phi \rangle;$$

the result (A.1) follows. Since functions in $H_{\#}^1(Y)$ can be periodically extended, the translation operation $\tau_{h,\ell} : v(\mathbf{y}) \rightarrow v(\mathbf{y} + h\mathbf{e}_\ell)$ is well-defined. Then, with the summation convention,

$$\begin{aligned} (\hat{\mathbf{A}} \nabla(\tau_{h,\ell} u), \nabla v)_Y &= (\hat{\mathbf{A}} \nabla u, \nabla(\tau_{-h,\ell} v))_Y = (f_0, \tau_{-h,\ell} v)_Y + (f_j, \partial_j(\tau_{-h,\ell} v))_Y \\ &= (\tau_{h,\ell} f_0, v)_Y + (\tau_{h,\ell} f_j, \partial_j v)_Y = (f_0, v)_Y + (f_j, \partial_j v)_Y, \end{aligned}$$

so that $u = \tau_{h,\ell} u$ for all $h \in \mathbb{R}$; therefore u does not depend on y_ℓ . \blacksquare

Lemma A.2 *If Condition 1.10 holds, then $\widehat{\chi}_j$, $j = 1, 2, 3$, defined by (4.3) exists, is unique, and satisfies $\widehat{\chi}_j \in H^{1+s}(Y) \cap C^1(\mathcal{P})$, for some $s > 0$, and $\widehat{\mu}$ defined by (4.18) exists, is unique, and satisfies $\widehat{\mu} \in C^1(\mathcal{P})$. Furthermore, if $\widehat{\mathbf{A}}$ and \widehat{n} do not depend on y_ℓ , then neither do $\widehat{\chi}_j$ and $\widehat{\mu}$.*

Proof. We first claim that both $\widehat{\chi}_j$ and μ satisfy equations of the form (A.1), (A.2) with $\langle f, 1 \rangle = 0$. For μ this is immediate from (4.18) and the fact that, by the definition of n^H (4.2), $(n^H - \widehat{n}, 1)_Y = 0$. For $\widehat{\chi}_j$, observe that, by its definition (4.3), for all $v \in H^1(Y)$,

$$-\left\langle \frac{\partial(\widehat{\mathbf{A}})_{j\ell}}{\partial y_\ell}, v \right\rangle = \left((\widehat{\mathbf{A}})_{j\ell}, \frac{\partial v}{\partial y_\ell} \right)_Y, \quad \text{so that} \quad -\left\langle \frac{\partial(\widehat{\mathbf{A}})_{j\ell}}{\partial y_\ell}, 1 \right\rangle = 0.$$

Therefore, by Lemma A.1, both $\widehat{\chi}_j$ defined by (4.3) and μ defined by (4.18) exist and are unique. The lemma also implies that if $\widehat{\mathbf{A}}$ and \widehat{n} do not depend on y_ℓ , then neither do $\widehat{\chi}_j$ and $\widehat{\mu}$.

We now give the details of the proof of the regularity for $\widehat{\chi}_j$; the proof of the regularity of $\widehat{\mu}$ is very similar. Our goal is to use

1. that, for functions depending on r variables, then, if $t > 0$, there exists $C > 0$ such that

$$\|v\|_{C^{0,t}(Y)} \lesssim \|v\|_{H^{r/2+t}(Y)} \quad (\text{A.4})$$

i.e., Sobolev embedding (see, e.g., [53, Theorem 3.26]), and

2. an elliptic regularity shift.

Regarding 2.: such a shift is well-known, at least in the non-periodic case. To go from the periodic case to the non-periodic case, we extend the functions u , f_0 and f_j in (A.1) and (A.2) by periodicity and multiply by a cutoff function, and obtain a problem posed in a bounded domain in $\Omega \subset \mathbb{R}^d$ with $Y \subset\subset \Omega$. We can then just use the standard interior regularity shift result; see, e.g., [53, Theorem 4.20].

We need to check that *both* the coefficient $\widehat{\mathbf{A}}$ of the PDE (4.3) *and* the right-hand side $-\partial(\widehat{\mathbf{A}})_{j\ell}/\partial y_\ell$ have sufficient regularity under either (a) or (b) in Condition 1.10.

If (a) holds, then both $\widehat{\mathbf{A}}$ and $\widehat{\chi}_j$ only depend on y_1 , so that (4.3) becomes

$$-\frac{d}{dy_1} \left((\widehat{\mathbf{A}})_{11} \frac{d\widehat{\chi}_j}{dy_1} \right) = -\frac{d(\widehat{\mathbf{A}})_{11}}{dy_1}.$$

Therefore, if $\widehat{\mathbf{A}}$ is piecewise $C^{0,1}$, then $d(\widehat{\mathbf{A}})_{11}/dy_1$ is piecewise L^2 , and $\widehat{\chi}_j$ is piecewise H^2 by elliptic regularity (see, e.g., [53, Theorem 4.20]). By (A.4), $\widehat{\chi}_j$ is C^0 and piecewise C^1 . By the definition of the Slobodeckii seminorm, if $0 \leq s < 1/2$, then a function that is locally H^s is in $H^s(Y)$. Therefore, $\nabla \widehat{\chi}_j \in H^s(Y)$ for $s < 1/2$; thus $\chi_j \in H^{1+s}(Y)$ for $s < 1/2$.

Finally, for (b), by integrating by parts piecewise the right-hand side of the variational problem defining $\widehat{\chi}_j$, we find that, for all $v \in H_{\sharp}^1(Y)$,

$$\begin{aligned} (\widehat{\mathbf{A}} \nabla \widehat{\chi}_j, \nabla v)_Y &= \sum_{\omega \in \mathcal{P}} \left((\widehat{\mathbf{A}})_{j\ell}, \frac{\partial v}{\partial y_\ell} \right)_\omega = \sum_{\omega \in \mathcal{P}} \left\{ \left((\widehat{\mathbf{A}})_{j\ell} \boldsymbol{\nu}_{\omega,\ell}, v \right)_{\partial\omega} - \left(\frac{\partial(\widehat{\mathbf{A}})_{j\ell}}{\partial y_\ell}, v \right)_\omega \right\} \\ &= \sum_{\Gamma \in \partial\mathcal{P}} \left([(\widehat{\mathbf{A}})_{j\ell}] \boldsymbol{\nu}_{\Gamma,\ell}, v \right)_\Gamma - \sum_{\omega \in \mathcal{P}} \left(\frac{\partial(\widehat{\mathbf{A}})_{j\ell}}{\partial y_\ell}, v \right)_\omega \end{aligned}$$

where $\partial\mathcal{P}$ denotes the set of interfaces of the partition, and $[\cdot]$ denotes the jump of a function across an interface Γ . By elliptic regularity (see, e.g. [53, Theorem 4.20]), since each Γ is $C^{2,1}$, the periodic extension of $\widehat{\mathbf{A}}$ is piecewise $C^{1,1}$ and hence piecewise H^2 , we have

$$\|\widehat{\chi}_j\|_{H^3(\mathcal{P})} \lesssim \left\| \frac{\partial(\widehat{\mathbf{A}})_{j\ell}}{\partial y_\ell} \right\|_{H^1(\mathcal{P})} + \sum_{\Gamma \in \partial\mathcal{P}} \| [(\widehat{\mathbf{A}})_{j\ell}] \cdot \boldsymbol{\nu}_{\ell,\Gamma} \|_{H^{3/2}(\Gamma)} \lesssim \|\widehat{\mathbf{A}}\|_{H^2(\mathcal{P})},$$

by continuity of the trace map $H^2(D) \rightarrow H^{3/2}(D)$ for a $C^{1,1}$ domain D (see, e.g., [53, Theorem 3.37]). By (A.4) with $r = 2$, $\nabla \widehat{\chi}_j \in C^{0,t}(\mathcal{P})$ for all $0 < t < 1$, and thus certainly $\widehat{\chi}_j \in C^1(\mathcal{P})$. Finally, exactly as in (a), since $\nabla \widehat{\chi}_j$ is locally H^s for $s \leq 2$, it is in $H^s(Y)$ for $s < 1/2$; thus $\chi_j \in H^{1+s}(Y)$ for $s < 1/2$. \blacksquare

B Periodic vector potentials

The goal of this appendix is to prove Theorem B.6 below, from which Lemma 4.5 follows.

B.1 Periodic Sobolev spaces

In this section $C^\infty(\mathbb{R}^d)$ is the space of smooth complex vector-valued functions; i.e., $C^\infty(\mathbb{R}^d) := C^\infty(\mathbb{R}^d; \mathbb{C}^d)$. $Y = (0, 1)^d$ is the d -dimensional unit cube. The space $C_{\text{per}}^\infty(Y)$ consists of those functions in $C^\infty(\mathbb{R}^d)$ that are Y -periodic, i.e. $\phi \in C^\infty(\mathbb{R}^d)$ and $\phi(\mathbf{y} + \mathbf{e}_j) = \phi(\mathbf{y})$ for all $\mathbf{y} \in \mathbb{R}^d$, where, for $1 \leq j \leq d$, \mathbf{e}_j denotes the j^{th} vector in the canonical basis of \mathbb{R}^d . For $\phi \in C_{\text{per}}^\infty(Y)$,

$$\begin{aligned} \|\phi\|_{\text{div}, Y}^2 &:= \|\phi\|_{L^2(Y)}^2 + \|\nabla_{\mathbf{y}} \cdot \phi\|_{L^2(Y)}^2, & \|\phi\|_{\text{curl}, Y}^2 &:= \|\phi\|_{L^2(Y)}^2 + \|\nabla_{\mathbf{y}} \times \phi\|_{L^2(Y)}^2, \\ \|\phi\|_{H^1(Y)}^2 &:= \|\phi\|_{L^2(Y)}^2 + \|\nabla_{\mathbf{y}} \phi\|_{L^2(Y)}^2, \end{aligned}$$

and $\mathbf{H}_{\text{per}}(\text{div}, Y)$, $\mathbf{H}_{\text{per}}(\text{curl}, Y)$ and $\mathbf{H}_{\text{per}}^1(Y)$ are the closures of $C_{\text{per}}^\infty(Y)$ in $L^2(Y)$ with respect to the $\|\cdot\|_{\text{div}, Y}$, $\|\cdot\|_{\text{curl}, Y}$ and $\|\cdot\|_{H^1(Y)}$ norms, respectively.

The spaces $C_{\#}^\infty(Y)$, $\mathbf{H}_{\#}(\text{div}, Y)$, $\mathbf{H}_{\#}(\text{curl}, Y)$ and $\mathbf{H}_{\#}^1(Y)$ are the subspaces of $C_{\text{per}}^\infty(Y)$, $\mathbf{H}_{\text{per}}(\text{div}, Y)$, $\mathbf{H}_{\text{per}}(\text{curl}, Y)$ and $\mathbf{H}_{\text{per}}^1(Y)$, respectively, consisting of functions with zero mean. Since the map $L^2(Y) \rightarrow \mathbb{C}^d$ defined by $\phi \mapsto \frac{1}{|Y|} \int_Y \phi$ is bounded, $C_{\#}^\infty(Y)$ is dense in $\mathbf{H}_{\#}(\text{div}, Y)$, $\mathbf{H}_{\#}(\text{curl}, Y)$, and $\mathbf{H}_{\#}^1(Y)$.

B.2 Fourier series

For $\alpha \in \mathbb{Z}^d$, let

$$|\alpha|^2 := \sum_{j=1}^d \alpha_j^2 \quad \text{and} \quad e^\alpha(\mathbf{y}) := e^{2\pi i \alpha \cdot \mathbf{y}} \quad \text{for all } \mathbf{y} \in \mathbb{R}^d.$$

For $\phi \in L_{\text{per}}^2(Y)$, we define $\phi^\alpha \in \mathbb{Z}^d$ by

$$(\phi^\alpha)_j := (\phi_j, e^\alpha)_{L^2(Y)} \quad \text{for all } \alpha \in \mathbb{Z}^d.$$

Then, by the L^2 theory of Fourier series (see, e.g., [77, §4.26, Page 91] for the results in one dimension, and, e.g., [37, Prop. 3.1.15 and 3.1.16, Page 170] for the results in arbitrary dimensions) $\sum_{\alpha \in \mathbb{Z}^d} |\phi^\alpha|^2 < \infty$ and

$$\phi = \sum_{\alpha \in \mathbb{Z}^d} \phi^\alpha e^\alpha,$$

where the sum converges in $L^2(Y)$. Conversely, if $\{\tilde{\psi}^\alpha\}_{\alpha \in \mathbb{Z}^d}$ is a set of coefficients satisfying $\sum_{\alpha} |\tilde{\psi}^\alpha|^2 < \infty$ then there exists a unique $\psi \in L^2(Y)$ such that $\psi^\alpha = \tilde{\psi}^\alpha$ and

$$\psi := \sum_{\alpha \in \mathbb{Z}^d} \psi^\alpha e^\alpha,$$

where the sum converges in $L^2(Y)$. If $\phi \in \mathbf{H}_{\text{per}}(\text{div}, Y)$ then, by the divergence theorem (see, e.g., [60, Part 2 of Theorem 3.24])

$$(\nabla_{\mathbf{y}} \cdot \phi)^\alpha = 2\pi i \alpha \cdot \phi^\alpha \quad \text{so that} \quad \nabla_{\mathbf{y}} \cdot \phi = 2\pi i \sum_{\alpha \in \mathbb{Z}^d} (\alpha \cdot \phi^\alpha) e^\alpha. \quad (\text{B.1})$$

Similarly if $\phi \in \mathbf{H}_{\text{per}}(\text{curl}, Y)$ then integration by parts (see, e.g., [60, Theorem 3.29]) gives

$$(\nabla_{\mathbf{y}} \times \phi)^\alpha = 2\pi i \alpha \times \phi^\alpha \quad \text{so that} \quad \nabla_{\mathbf{y}} \times \phi = 2\pi i \sum_{\alpha \in \mathbb{Z}^d} (\alpha \times \phi^\alpha) e^\alpha. \quad (\text{B.2})$$

B.3 Sobolev norms defined by Fourier coefficients

For $s \in \mathbb{R}_+$, we define the Sobolev semi-norms on vector- and scalar-valued functions by

$$|\phi|_{\mathbf{H}^s(Y)}^2 := (2\pi)^s \sum_{\alpha \in \mathbb{Z}^d} |\alpha|^{2s} |\phi^\alpha|^2 \quad \text{and} \quad |\phi|_{\mathbf{H}^s(Y)}^2 := (2\pi)^s \sum_{\alpha \in \mathbb{Z}^d} |\alpha|^{2s} |\phi^\alpha|^2; \quad (\text{B.3})$$

where $|\cdot|_2$ denotes the Euclidean norm on \mathbb{C}^d (and the modulus on \mathbb{C}); observe that then

$$|\phi|_{\mathbf{H}^s(Y)}^2 = \sum_{j=1}^d |\phi_j|_{\mathbf{H}^s(Y)}^2 \quad (\text{B.4})$$

Let

$$\|\phi\|_{\mathbf{H}^m(Y)}^2 := \sum_{s=0}^m |\phi|_{\mathbf{H}^s(Y)}^2, \quad m \in \mathbb{Z}^+, \quad \text{and} \quad \|\phi\|_{\mathbf{H}^t(Y)}^2 := \sum_{s=0}^{\lfloor t \rfloor} |\phi|_{\mathbf{H}^s(Y)}^2 + |\phi|_{\mathbf{H}^t(Y)}^2, \quad t \in \mathbb{R}^+ \setminus \mathbb{Z}^+, \quad (\text{B.5})$$

and similarly for scalar-valued functions. We use below the particular consequence of (B.4) and (B.5) that

$$\|\phi\|_{\mathbf{H}^{1+s}(Y)}^2 = \sum_{j=1}^d \|\phi_j\|_{\mathbf{H}^{1+s}(Y)}^2. \quad (\text{B.6})$$

Lemma B.1 *Let $0 \leq s \leq 1$. If $\phi \in \mathbf{H}_{\text{per}}(\text{div}, Y)$ with $\nabla_{\mathbf{y}} \cdot \phi = 0$ and $\nabla_{\mathbf{y}} \times \phi \in \mathbf{H}^s(Y)$, then $\phi \in \mathbf{H}^{1+s}(Y)$ with*

$$|\phi|_{\mathbf{H}^{1+s}(Y)} \leq |\nabla_{\mathbf{y}} \times \phi|_{\mathbf{H}^s(Y)}. \quad (\text{B.7})$$

An immediate consequence of Lemma B.1 is that

$$\text{if } \phi \in \mathbf{H}_{\text{per}}(\text{div}, Y) \cap \mathbf{H}_{\text{per}}(\text{curl}, Y) \text{ then } \phi \in \mathbf{H}_{\text{per}}^1(Y). \quad (\text{B.8})$$

Proof of Lemma B.1. The identity

$$|\alpha|^2 \mathbf{v} = (\alpha \cdot \mathbf{v}) \alpha + (\alpha \times \mathbf{v}) \times \alpha,$$

holds for all $\alpha \in \mathbb{Z}^d$ and $\mathbf{v} \in \mathbb{C}^d$. Using this with $\mathbf{v} = \phi^\alpha$, along with (B.1) and (B.2), we have

$$\begin{aligned} 2\pi i |\alpha|^2 \phi^\alpha &= 2\pi i (\alpha \cdot \phi^\alpha) \alpha + 2\pi i (\alpha \times \phi^\alpha) \times \alpha = (\nabla_{\mathbf{y}} \cdot \phi)^\alpha \alpha + (\nabla_{\mathbf{y}} \times \phi)^\alpha \times \alpha \\ &= (\nabla_{\mathbf{y}} \times \phi)^\alpha \times \alpha, \end{aligned}$$

since $\nabla_{\mathbf{y}} \cdot \phi = 0$ by assumption. Therefore

$$2\pi |\alpha| |\phi^\alpha| = \frac{|(\nabla_{\mathbf{y}} \times \phi)^\alpha \times \alpha|}{|\alpha|} \leq |(\nabla_{\mathbf{y}} \times \phi)^\alpha|.$$

Recalling the definition (B.3), we have

$$\begin{aligned} |\phi|_{\mathbf{H}^{1+s}(Y)}^2 &= (2\pi)^{2(1+s)} \sum_{\alpha \in \mathbb{Z}^d} |\alpha|^{2(1+s)} |\phi^\alpha|^2 = (2\pi)^{2s} \sum_{\alpha \in \mathbb{Z}^d} |\alpha|^{2s} (2\pi |\alpha| |\phi^\alpha|)^2 \\ &\leq (2\pi)^{2s} \sum_{\alpha \in \mathbb{Z}^d} |\alpha|^{2s} |(\nabla_{\mathbf{y}} \times \phi)^\alpha|^2 = |\nabla_{\mathbf{y}} \times \phi|_{\mathbf{H}^s(Y)}^2. \end{aligned}$$

■

B.4 Univariate vector potentials

Lemma B.2 For all $\phi \in \mathbf{H}_{\sharp}(\operatorname{div}, Y)$ with $\nabla_{\mathbf{y}} \cdot \phi = 0$, there exists a unique $\mathbf{q} \in \mathbf{H}_{\sharp}^1(Y)$ such that

$$\nabla_{\mathbf{y}} \times \mathbf{q} = \phi \quad \text{and} \quad \nabla_{\mathbf{y}} \cdot \mathbf{q} = 0. \quad (\text{B.9})$$

In addition,

$$\|\mathbf{q}\|_{\mathbf{H}^1(Y)} \leq \left(1 + \frac{1}{\pi}\right) \|\phi\|_{\mathbf{L}^2(Y)}. \quad (\text{B.10})$$

The analogue of Lemma B.2 in bounded domains appears in, e.g., [35, Theorem 3.4].

Proof of Lemma B.2. Under the assumption that the solution $\mathbf{q} \in \mathbf{H}_{\sharp}^1(Y)$ exists and is unique, the inequality (B.7) with $s = 0$ shows that

$$\|\mathbf{q}\|_{\mathbf{H}^1(Y)} \leq \|\nabla_{\mathbf{y}} \times \mathbf{q}\|_{\mathbf{L}^2(Y)} = \|\phi\|_{\mathbf{L}^2(Y)}.$$

Since the mean value of \mathbf{q} vanishes and Y is convex, the Poincaré inequality

$$\|\mathbf{q}\|_{\mathbf{L}^2(Y)} \leq \frac{1}{\pi} \|\mathbf{q}\|_{\mathbf{H}^1(Y)},$$

holds, and (B.10) immediately follows. We now show that if the solution to (B.10) exists, it is necessarily unique. It is sufficient to prove that if $\phi = \mathbf{0}$, then $\mathbf{q} = \mathbf{0}$. If $\phi = \mathbf{0}$ then $\nabla_{\mathbf{y}} \times \mathbf{q} = \mathbf{0}$, and $\|\mathbf{q}\|_{\mathbf{H}^1(Y)} = 0$ by (B.7); therefore \mathbf{q} is constant. But since $\mathbf{q} \in \mathbf{H}_{\sharp}^1(Y)$, its mean value vanishes, showing that $\mathbf{q} = \mathbf{0}$. It remains to prove existence; given $\phi \in \mathbf{H}_{\sharp}(\operatorname{div}, Y)$, define the vector \mathbf{q}^{α} by

$$\mathbf{q}^{\mathbf{0}} := \mathbf{0}, \quad \mathbf{q}^{\alpha} := -\frac{1}{2\pi i} \frac{\alpha \times \phi^{\alpha}}{|\alpha|^2}, \quad \alpha \in \mathbb{Z}^d \setminus \{\mathbf{0}\}. \quad (\text{B.11})$$

Since $\sum_{\alpha \in \mathbb{Z}^d} |\mathbf{q}^{\alpha}|^2 \leq (2\pi)^{-1} \sum_{\alpha} |\phi^{\alpha}|^2 < \infty$, the results recapped in §B.2 imply that

$$\mathbf{q} := \sum_{\alpha \in \mathbb{Z}^d} \mathbf{q}^{\alpha} e^{\alpha} \in \mathbf{L}^2(Y).$$

Since $(\mathbf{q}, 1)_Y = \mathbf{q}^{\mathbf{0}} = \mathbf{0}$, $\mathbf{q} \in \mathbf{L}_{\sharp}^2(Y)$. It remains to show that \mathbf{q} satisfies (B.9), since then the fact that $\mathbf{q} \in \mathbf{H}_{\sharp}^1(Y)$ will then follow from $\phi \in \mathbf{L}^2(Y)$ and the relation (B.8).

First, since $\alpha \cdot (\alpha \times \mathbf{v}) = 0$ for all $\mathbf{v} \in \mathbb{C}^d$, $\alpha \cdot \mathbf{q}^{\alpha} = 0$ for all $\alpha \in \mathbb{Z}^d$; therefore (B.1) implies that $\nabla_{\mathbf{y}} \cdot \mathbf{q} = 0$. Next, the fact that $\nabla_{\mathbf{y}} \cdot \phi = 0$ implies by (B.1) that $\alpha \cdot \phi^{\alpha} = 0$ for all $\alpha \in \mathbb{Z}^d \setminus \{\mathbf{0}\}$. Therefore,

$$|\alpha|^2 \phi^{\alpha} = (\alpha \cdot \phi^{\alpha}) \alpha + (\alpha \times \phi^{\alpha}) \times \alpha = (\alpha \times \phi^{\alpha}) \times \alpha = 2\pi i |\alpha|^2 (\alpha \times \mathbf{q}^{\alpha}),$$

and therefore

$$2\pi i (\alpha \times \mathbf{q}^{\alpha}) = \phi^{\alpha} \quad (\text{B.12})$$

for all $\alpha \in \mathbb{Z}^d \setminus \{\mathbf{0}\}$. For $\alpha = \mathbf{0}$,

$$2\pi i (\alpha \times \mathbf{q}^{\alpha}) = \mathbf{0} = \phi^{\alpha}, \quad (\text{B.13})$$

since $\phi \in \mathbf{H}_{\sharp}(\operatorname{div}, Y)$. Combining (B.12), (B.13), and (B.2), we find that $\nabla_{\mathbf{y}} \times \mathbf{q} = \phi$, which concludes the proof. \blacksquare

The next lemma involves the $\mathbf{L}^{\infty}(Y)$ and $L^{\infty}(Y)$ norms defined by

$$\|\mathbf{q}\|_{\mathbf{L}^{\infty}(Y)} := \operatorname{ess\,sup}_{\mathbf{y} \in Y} |\mathbf{q}(\mathbf{y})|_2 \quad \text{and} \quad \|q\|_{L^{\infty}(Y)} := \operatorname{ess\,sup}_{\mathbf{y} \in Y} |q(\mathbf{y})|. \quad (\text{B.14})$$

Theorem B.3 Let $\phi \in \mathbf{H}_{\sharp}(\operatorname{div}, Y)$ with $\nabla_{\mathbf{y}} \cdot \phi = 0$, and assume that ϕ does not depend on the y_d variable.

(i) If $\mathbf{q} \in \mathbf{H}_{\sharp}^1(Y)$ is the unique solution to (B.9), then \mathbf{q} does not depend on the y_d variable.

(ii) If, in addition, $\phi \in \mathbf{H}^s(Y)$ for some $s > 0$, then $\mathbf{q} \in \mathbf{L}^{\infty}(Y)$ and there exists $C_{\operatorname{emb}, s} > 0$ such that

$$\|\mathbf{q}\|_{\mathbf{L}^{\infty}(Y)} \leq C_{\operatorname{emb}, s} \left(1 + \frac{1}{\pi}\right) \|\phi\|_{\mathbf{H}^s(Y)}. \quad (\text{B.15})$$

Proof. (i) We consider the case $d = 3$; the case $d = 2$ is very similar (and easier). For $\mathbf{y} \in \mathbb{R}^3$, we write $\mathbf{y} = (\mathbf{y}', y_3)$ for $\mathbf{y}' \in Y' = (0, 1)^2$. Similarly, for $\boldsymbol{\psi} \in \mathbb{R}^3$ we write $\boldsymbol{\psi} = (\boldsymbol{\psi}', \psi_3)$. We introduce the notation that, for $\boldsymbol{\psi}'(\mathbf{y}')$ a two-dimensional vector independent of y_3 , $\operatorname{div}_{\mathbf{y}'} \boldsymbol{\psi}' := \partial_{y_1} \psi'_1 + \partial_{y_2} \psi'_2$ and $\operatorname{curl}_{\mathbf{y}'} \boldsymbol{\psi}' := \partial_{y_1} \psi'_2 - \partial_{y_2} \psi'_1$. Furthermore, if $\psi_3(\mathbf{y}')$ is a scalar field that does not depend on y_3 , then $\mathbf{curl}_{\mathbf{y}'} \psi_3 := (\partial_{y_2} \psi_3, -\partial_{y_1} \psi_3)$ (i.e. $\mathbf{curl}_{\mathbf{y}'}$ is the rotation of the gradient of ψ). These definitions imply that, if $\boldsymbol{\psi} = (\boldsymbol{\psi}', \psi_3)$ is a vector field that does not depend on y_3 , then

$$\mathbf{curl}_{\mathbf{y}} \boldsymbol{\psi} = (\mathbf{curl}_{\mathbf{y}'} \psi_3, \operatorname{curl}_{\mathbf{y}'} \boldsymbol{\psi}'). \quad (\text{B.16})$$

Now, since $\boldsymbol{\phi}$ is independent of y_3 and $\nabla_{\mathbf{y}} \cdot \boldsymbol{\phi} = 0$, $\operatorname{div}_{\mathbf{y}'} \boldsymbol{\phi}' = 0$. Observe that, with the notation $\boldsymbol{\phi} = (\boldsymbol{\phi}', \phi_3)$, both $\boldsymbol{\phi}'$ and ϕ_3 have mean value zero. Using the lower-dimensional analogues of the Fourier-series argument used to prove Lemma B.2, one can show that there exists a unique $p_d \in H_{\sharp}(\mathbf{curl}, Y')$ and a unique $\mathbf{p}' \in \mathbf{H}_{\sharp}(\operatorname{curl}, Y')$ such that

$$\mathbf{curl}_{\mathbf{y}'} p_3 = \boldsymbol{\phi}', \quad \begin{cases} \operatorname{curl}_{\mathbf{y}'} \mathbf{p}' = \boldsymbol{\phi}_3, \\ \operatorname{div}_{\mathbf{y}'} \mathbf{p}' = 0. \end{cases} \quad (\text{B.17})$$

Indeed, the Fourier coefficients of p_3 and \mathbf{p}' are given by

$$(p_3)^{\boldsymbol{\alpha}} = \begin{cases} |\boldsymbol{\alpha}|^{-2}(\alpha_2, -\alpha_1) \cdot (\boldsymbol{\phi}')^{\boldsymbol{\alpha}}, & \boldsymbol{\alpha} \neq \mathbf{0}, \\ 0, & \boldsymbol{\alpha} = \mathbf{0}, \end{cases} \quad \text{and} \quad (\mathbf{p}')^{\boldsymbol{\alpha}} = \begin{cases} |\boldsymbol{\alpha}|^{-2}(\alpha_2, -\alpha_1)(\boldsymbol{\phi}_d)^{\boldsymbol{\alpha}}, & \boldsymbol{\alpha} \neq \mathbf{0}, \\ 0, & \boldsymbol{\alpha} = \mathbf{0}, \end{cases}$$

(compare to (B.11)). We then set $\mathbf{p} := (\mathbf{p}', p_3)$. Since \mathbf{p}' and p_3 both have mean value zero, so does \mathbf{p} . Since \mathbf{p} is independent of y_3 , (B.16) implies that

$$\nabla_{\mathbf{y}} \times \mathbf{p} = (\mathbf{curl}_{\mathbf{y}'} p_3, \operatorname{curl}_{\mathbf{y}'} \mathbf{p}'),$$

which equals $\boldsymbol{\phi}$ by (B.17); therefore $\mathbf{p} \in \mathbf{H}_{\sharp}(\mathbf{curl}, Y)$. Since $\nabla_{\mathbf{y}} \cdot \mathbf{p} = \operatorname{div}_{\mathbf{y}'} \mathbf{p}' + \partial p_3 / \partial y_3 = 0$, $\mathbf{p} \in \mathbf{H}_{\sharp}(\operatorname{div}, Y)$ and then the relation (B.8) implies that $\mathbf{p} \in \mathbf{H}_{\sharp}^1(Y)$. Since the solution to (B.9) is unique by Lemma B.2, $\mathbf{q} = \mathbf{p}$, so that \mathbf{q} does not depend on y_3 .

(ii) Since $\nabla \times \mathbf{q} = \boldsymbol{\phi} \in \mathbf{H}^s(Y)$, $\mathbf{q} \in \mathbf{H}^{1+s}(Y)$ by Lemma B.1, with

$$|\mathbf{q}|_{\mathbf{H}^{1+s}(Y)} \leq |\boldsymbol{\phi}|_{\mathbf{H}^s(Y)}.$$

Using this with (B.10), we find that

$$\begin{aligned} \|\mathbf{q}\|_{\mathbf{H}^{1+s}(Y)}^2 &= \|\mathbf{q}\|_{\mathbf{H}^1(Y)}^2 + |\mathbf{q}|_{\mathbf{H}^{1+s}(Y)}^2 \\ &\leq \left(1 + \frac{1}{\pi}\right)^2 \|\boldsymbol{\phi}\|_{\mathbf{L}^2(Y)}^2 + |\boldsymbol{\phi}|_{\mathbf{H}^s(Y)}^2 \leq \left(1 + \frac{1}{\pi}\right)^2 \|\boldsymbol{\phi}\|_{\mathbf{H}^s(Y)}^2, \end{aligned} \quad (\text{B.18})$$

Our goal is now to use Sobolev embedding to bound $\|\mathbf{q}\|_{\mathbf{L}^\infty(Y)}$ by $\|\mathbf{q}\|_{\mathbf{H}^{1+s}(Y)}$. Recall that $\|v\|_{\mathbf{L}^\infty} \lesssim \|v\|_{\mathbf{H}^{d/2+s}}$ for $0 < s < 1$ (see, e.g., [53, Theorem 3.26]), indicating that for $d = 3$ we require the $\mathbf{H}^{3/2+s}$ norm of \mathbf{q} . However, since \mathbf{q} and its components are only functions of $\mathbf{y}' \in Y' \subset \mathbb{R}^{d-1}$, and $d - 1 \leq 2$, we only require the \mathbf{H}^{1+s} norm of \mathbf{q} . Given $0 < s < 1$, there exists a constant $C_{\text{emb},s}$ such that

$$\|\boldsymbol{\psi}\|_{\mathbf{L}^\infty(Y')} \leq C_{\text{emb},s} \|\boldsymbol{\psi}\|_{\mathbf{H}^{1+s}(Y')} \quad \text{for all } \boldsymbol{\psi} \in \mathbf{H}^{1+s}(Y'). \quad (\text{B.19})$$

Using (in this order) the definition of the $\mathbf{L}^\infty(Y)$ norm (B.14), the bound (B.19), the fact that (by Part (i)) $\mathbf{q} \in \mathbf{H}^{1+s}(Y)$ and does not depend on the y_d variable, and the property (B.6), we have

$$\|\mathbf{q}\|_{\mathbf{L}^\infty(Y)}^2 \leq \sum_{j=1}^d \|q_j\|_{\mathbf{L}^\infty(Y')}^2 \leq C_{\text{emb},s}^2 \sum_{j=1}^d \|q_j\|_{\mathbf{H}^{1+s}(Y')}^2 = C_{\text{emb},s}^2 \|\mathbf{q}\|_{\mathbf{H}^{1+s}(Y)}^2. \quad (\text{B.20})$$

The result (B.15) then follows from combining (B.20) and (B.18) ■

B.5 Bivariate vector potentials

We now consider functions $\phi : D_{\text{in}} \times Y \rightarrow \mathbb{C}$ such that

$$\phi(\mathbf{x}, \mathbf{y}) = \widehat{\mathbf{M}}(\mathbf{y})\mathbf{v}(\mathbf{x}), \quad (\text{B.21a})$$

where $\widehat{\mathbf{M}}$ is a Y -periodic matrix-valued function with zero mean value that does not depend on y_d and is such that

$$\widehat{\mathbf{M}}_{j\ell} \in H^s(Y) \cap L^\infty(Y) \quad (\text{B.21b})$$

for some fixed $s > 0$, and $\mathbf{v} \in \mathbf{H}^2(D_{\text{in}})$. We further assume that

$$\nabla_{\mathbf{y}} \cdot \phi(\mathbf{x}, \cdot) = 0$$

in the sense of distribution for a.e. $\mathbf{x} \in D_{\text{in}}$.

Lemma B.4 *Assume that ϕ satisfies (B.21) and additionally that $\mathbf{v} \in C^\infty(\overline{D_{\text{in}}})$. Then, for all $\mathbf{x} \in \overline{D_{\text{in}}}$, there exists a unique $\mathbf{q}(\mathbf{x}, \cdot) \in \mathbf{H}_{\sharp}^1(Y)$ such that*

$$\nabla_{\mathbf{y}} \times \mathbf{q}(\mathbf{x}, \cdot) = \phi(\mathbf{x}, \cdot) \quad \text{and} \quad \nabla_{\mathbf{y}} \cdot \mathbf{q}(\mathbf{x}, \cdot) = 0 \quad (\text{B.22})$$

for all $\mathbf{y} \in Y$. Furthermore, $\mathbf{q} \in C^\infty(\overline{D_{\text{in}}}, \mathbf{H}_{\sharp}^1(Y))$ with

$$\|(\partial_{\mathbf{x}}^{\boldsymbol{\beta}} \mathbf{q})(\mathbf{x}, \cdot)\|_{\mathbf{H}^1(Y)} \leq \left(1 + \frac{1}{\pi}\right) \|\widehat{\mathbf{M}}(\cdot) \partial_{\mathbf{x}}^{\boldsymbol{\beta}} \mathbf{v}(\mathbf{x}, \cdot)\|_{\mathbf{L}^2(Y)} \quad (\text{B.23})$$

and $\mathbf{q}(\mathbf{x}, \cdot) \in C^\infty(\overline{D_{\text{in}}}, \mathbf{L}^\infty(Y))$ with

$$\|(\partial_{\mathbf{x}}^{\boldsymbol{\beta}} \mathbf{q})(\mathbf{x}, \cdot)\|_{\mathbf{L}^\infty(Y)} \leq C_{\text{emb},s} \left(1 + \frac{1}{\pi}\right) \|\widehat{\mathbf{M}}\|_{\mathbf{H}^s(Y)} |(\partial^{\boldsymbol{\beta}} \mathbf{v})(\mathbf{x})| \quad (\text{B.24})$$

for all $\boldsymbol{\beta} \in \mathbb{Z}_+^d$ and $\mathbf{x} \in \overline{D_{\text{in}}}$. In particular,

$$\|(\partial_{\mathbf{x}}^{\boldsymbol{\beta}} \mathbf{q})^\varepsilon\|_{\mathbf{L}^2(D_{\text{in}})} \leq C_{\text{emb},s} \left(1 + \frac{1}{\pi}\right) \|\widehat{\mathbf{M}}\|_{\mathbf{H}^s(Y)} \|\partial^{\boldsymbol{\beta}} \mathbf{v}\|_{\mathbf{L}^2(D_{\text{in}})}, \quad (\text{B.25})$$

and

$$\|(\partial_{\mathbf{x}}^{\boldsymbol{\beta}} \mathbf{q})^\varepsilon\|_{\mathbf{L}^2(\Gamma)} \leq C_{\text{emb},s} \left(1 + \frac{1}{\pi}\right) \|\widehat{\mathbf{M}}\|_{\mathbf{H}^s(Y)} \|\partial^{\boldsymbol{\beta}} \mathbf{v}\|_{\mathbf{L}^2(\Gamma)}, \quad (\text{B.26})$$

for all $\boldsymbol{\beta} \in \mathbb{Z}_+^d$.

Proof. The existence and uniqueness of the solution $\mathbf{q}(\mathbf{x}, \cdot) \in \mathbf{H}_{\sharp}^1(Y)$ for all $\mathbf{x} \in \overline{D_{\text{in}}}$ is a direct consequence of Theorem B.3. Now, set $\delta > 0$ and define $D_{\text{in}}^\delta \subset D_{\text{in}}$ as the subset of D_{in} of distance $\geq \delta$ from Γ . With $\mathbf{x} \in D_{\text{in}}^\delta$ and $\mathbf{x}' \in D_{\text{in}}$,

$$\begin{cases} \nabla_{\mathbf{y}} \times (\mathbf{q}(\mathbf{x}, \cdot) - \mathbf{q}(\mathbf{x}', \cdot)) &= \phi(\mathbf{x}, \cdot) - \phi(\mathbf{x}', \cdot) \\ \nabla_{\mathbf{y}} \cdot (\mathbf{q}(\mathbf{x}, \cdot) - \mathbf{q}(\mathbf{x}', \cdot)) &= 0, \end{cases}$$

so that, by (B.10),

$$\begin{aligned} \|\mathbf{q}(\mathbf{x}, \cdot) - \mathbf{q}(\mathbf{x}', \cdot)\|_{\mathbf{H}^1(Y)} &\leq \left(1 + \frac{1}{\pi}\right) \|\phi(\mathbf{x}, \cdot) - \phi(\mathbf{x}', \cdot)\|_{\mathbf{L}^2(Y)} \\ &\leq \left(1 + \frac{1}{\pi}\right) |\mathbf{x} - \mathbf{x}'| \sup_{\mathbf{x} \in D_{\text{in}}} \|\widehat{\mathbf{M}}(\cdot) \nabla_{\mathbf{x}} \mathbf{v}(\mathbf{x}, \cdot)\|_{\mathbf{L}^2(Y)}, \end{aligned}$$

and, by (B.15),

$$\|\mathbf{q}(\mathbf{x}, \cdot) - \mathbf{q}(\mathbf{x}', \cdot)\|_{\mathbf{L}^\infty(Y)} \leq C_{\text{emb},s} \left(1 + \frac{1}{\pi}\right) \|\phi(\mathbf{x}, \cdot) - \phi(\mathbf{x}', \cdot)\|_{\mathbf{H}^s(Y)},$$

$$\leq C_{\text{emb},s} \left(1 + \frac{1}{\pi}\right) |\mathbf{x} - \mathbf{x}'| \sup_{\mathbf{x} \in D_{\text{in}}} \|\widehat{\mathbf{M}}(\cdot) \nabla_{\mathbf{x}} \mathbf{v}(\mathbf{x}, \cdot)\|_{\mathbf{H}^s(Y)}.$$

Since the above inequalities hold for any $\mathbf{x}' \in D_{\text{in}}$, we deduce that

$$\sup_{\mathbf{x} \in D_{\text{in}}^\delta} \|\nabla_{\mathbf{x}} \mathbf{q}(\mathbf{x}, \cdot)\|_{\mathbf{H}^1(Y)} \leq \left(1 + \frac{1}{\pi}\right) \sup_{\mathbf{x} \in D_{\text{in}}} \|\widehat{\mathbf{M}}(\cdot) \nabla_{\mathbf{x}} \mathbf{v}(\mathbf{x}, \cdot)\|_{\mathbf{L}^2(Y)},$$

and

$$\sup_{\mathbf{x} \in D_{\text{in}}^\delta} \|\nabla_{\mathbf{x}} \mathbf{q}(\mathbf{x}, \cdot)\|_{\mathbf{L}^\infty(Y)} \leq C_{\text{emb},s} \left(1 + \frac{1}{\pi}\right) \sup_{\mathbf{x} \in D_{\text{in}}} \|\widehat{\mathbf{M}}(\cdot) \nabla_{\mathbf{x}} \mathbf{v}(\mathbf{x}, \cdot)\|_{\mathbf{H}^s(Y)}.$$

But now, since the upper bounds are independent of δ , we obtain (B.23) and (B.24) for $|\beta| = 1$ by letting $\delta \rightarrow 0$. We have there proved that $\mathbf{q} \in C^1(\overline{D_{\text{in}}}, \mathbf{H}^1(Y)) \cap C^1(\overline{D_{\text{in}}}, \mathbf{L}^\infty(Y))$; we can therefore differentiate (B.22) with respect to x_j , to obtain that $\partial_{x_j} \mathbf{q} \in C^0(\overline{D_{\text{in}}}, \mathbf{H}^1(Y)) \cap C^0(\overline{D_{\text{in}}}, \mathbf{L}^\infty(Y))$. By linearity, we can then repeating the above argument with $\tilde{\mathbf{q}} := \partial_{x_j} \mathbf{q}$ and $\tilde{\phi} = \partial_{x_j} \phi$. We then obtain (B.23) and (B.24) by induction on $|\beta|$.

By integrating over D_{in} and using (B.24), we have

$$\begin{aligned} \|(\partial_{\mathbf{x}}^\beta \mathbf{q})^\varepsilon\|_{\mathbf{L}^2(D_{\text{in}})}^2 &= \int_{D_{\text{in}}} \left| (\partial_{\mathbf{x}}^\beta \mathbf{q}) \left(\mathbf{x}, \frac{\mathbf{x}}{\varepsilon} \right) \right|^2 d\mathbf{x} \leq \int_{D_{\text{in}}} \|(\partial_{\mathbf{x}}^\beta \mathbf{q})(\mathbf{x}, \cdot)\|_{\mathbf{L}^\infty(Y)}^2 d\mathbf{x}, \\ &\leq (C_{\text{emb},s})^2 \left(1 + \frac{1}{\pi}\right)^2 \|\widehat{\mathbf{M}}\|_{\mathbf{H}^s(Y)}^2 \int_{D_{\text{in}}} |(\partial^\beta \mathbf{v})(\mathbf{x})|^2 d\mathbf{x}, \end{aligned} \quad (\text{B.27})$$

and (B.25) follows. The bound (B.26) follows similarly, but integrating over Γ . \blacksquare

Theorem B.5 *Assume that $\phi : D_{\text{in}} \times Y \rightarrow \mathbb{C}$ satisfies the three conditions in (B.21) with $\mathbf{v} \in \mathbf{H}^2(D_{\text{in}})$. Then there exists a unique vector potential $\mathbf{q} \in \mathbf{H}^2(D_{\text{in}}, \mathbf{H}_\sharp^1(Y))$ such that*

$$\nabla_{\mathbf{y}} \times \mathbf{q}(\mathbf{x}, \cdot) = \phi(\mathbf{x}, \cdot) \quad \text{and} \quad \nabla_{\mathbf{y}} \cdot \mathbf{q}(\mathbf{x}, \cdot) = 0$$

for a.e. $\mathbf{x} \in D_{\text{in}}$. Furthermore,

$$\|(\nabla_{\mathbf{x}} \times \mathbf{q})^\varepsilon\|_{\mathbf{L}^2(D_{\text{in}})} \leq C_{\text{emb},s} \left(1 + \frac{1}{\pi}\right) \|\widehat{\mathbf{M}}\|_{\mathbf{H}^s(Y)} |\mathbf{v}|_{\mathbf{H}^1(D_{\text{in}})}, \quad (\text{B.28})$$

$$\|\nabla \times \mathbf{q}^\varepsilon \cdot \boldsymbol{\nu}\|_{\mathbf{H}^{-1}(\Gamma)} \leq \|\mathbf{q}^\varepsilon \times \boldsymbol{\nu}\|_{\mathbf{L}^2(\Gamma)} \leq C_{\text{emb},s} \left(1 + \frac{1}{\pi}\right) \|\widehat{\mathbf{M}}\|_{\mathbf{H}^s(Y)} \|\mathbf{v}\|_{\mathbf{L}^2(\Gamma)}, \quad (\text{B.29})$$

and

$$\|\nabla \times \mathbf{q}^\varepsilon \cdot \boldsymbol{\nu}\|_{\mathbf{L}^2(\Gamma)} \leq \frac{1}{\varepsilon} \|\widehat{\mathbf{M}}\|_{\mathbf{L}^\infty(Y)} \|\mathbf{v}\|_{\mathbf{L}^2(\Gamma)} + C_{\text{emb},s} \left(1 + \frac{1}{\pi}\right) \|\widehat{\mathbf{M}}\|_{\mathbf{H}^s(Y)} |\mathbf{v}|_{\mathbf{H}^1(\Gamma)}. \quad (\text{B.30})$$

In addition, if $kR_0 \gtrsim 1$,

$$\|\nabla \times \mathbf{q}^\varepsilon \cdot \boldsymbol{\nu}\|_{\mathbf{H}^{-1/2}(\Gamma)} \lesssim (1 + (k\varepsilon)^{-1/2}) \left(k \|\mathbf{v}\|_{\mathbf{L}^2(D_{\text{in}})} + |\mathbf{v}|_{\mathbf{H}^1(D_{\text{in}})}\right) \quad (\text{B.31})$$

(where the omitted constants depend on $\|\widehat{\mathbf{M}}\|_{\mathbf{H}^s(Y)}$ and $\|\widehat{\mathbf{M}}\|_{\mathbf{L}^\infty(Y)}$).

Proof. Once we have shown that \mathbf{q} exists, is unique, and satisfies the bounds (B.25) and (B.26) for $|\beta| \leq 1$ the bound (B.28) is a direct consequence of (B.25), and the bound on $\|\mathbf{q}^\varepsilon \times \boldsymbol{\nu}\|_{\mathbf{L}^2(\Gamma)}$ in (B.29) is a direct consequence of (B.26). We now prove the bound

$$\|\nabla \times \mathbf{q}^\varepsilon \cdot \boldsymbol{\nu}\|_{\mathbf{H}^{-1}(\Gamma)} \leq \|\mathbf{q}^\varepsilon \times \boldsymbol{\nu}\|_{\mathbf{L}^2(\Gamma)} \quad (\text{B.32})$$

to complete the proof of (B.29). Consider a test function $\phi \in C^\infty(\overline{D_{\text{in}}})$. Observe that

$$(\nabla \times \mathbf{q}^\varepsilon \cdot \boldsymbol{\nu}, \phi)_\Gamma = (\nabla \times \mathbf{q}^\varepsilon, \nabla \phi)_{D_{\text{in}}} = -(\mathbf{q}^\varepsilon \times \boldsymbol{\nu}, \nabla \phi)_\Gamma,$$

with the first equality holding by the divergence theorem and the fact that $\nabla \cdot (\nabla \times \mathbf{q}^\varepsilon) = 0$, and the second equality holding by the Green-type identity in, e.g., [60, Theorem 3.29] and the fact that $\nabla \times (\nabla \phi) = \mathbf{0}$. The bound (B.32) then follows since $\gamma(C^\infty(\overline{D_{\text{in}}}))$ is dense in $H^1(\Gamma)$ (see, e.g., [19, Page 276]).

To prove (B.30), we observe that, by (4.1),

$$\nabla \times \mathbf{q}^\varepsilon = (\nabla_{\mathbf{x}} \times \mathbf{q})^\varepsilon + \frac{1}{\varepsilon} (\nabla_{\mathbf{y}} \times \mathbf{q})^\varepsilon = (\nabla_{\mathbf{x}} \times \mathbf{q})^\varepsilon + \frac{1}{\varepsilon} \widehat{\mathbf{M}}^\varepsilon \mathbf{v}.$$

Since $(\widehat{\mathbf{M}})_{j\ell} \in L^\infty(Y)$ for $1 \leq j, \ell \leq d$, (B.30) follows from this last equality by taking norms and using (B.26).

To prove (B.31), we let $T : \mathbf{L}^2(\Gamma) \rightarrow \mathbf{H}^{-1}(\Gamma)$ be the operator $T : \mathbf{v} \rightarrow \nabla \times \mathbf{q}^\varepsilon \cdot \boldsymbol{\nu}$. By interpolation (see, e.g., [53, Appendix B]) using the bounds (B.29) and (B.30) (similar to in the proof of Lemma 4.3), we have

$$\|\nabla \times \mathbf{q}^\varepsilon \cdot \boldsymbol{\nu}\|_{\mathbf{H}^{-1/2}(\Gamma)} \lesssim \varepsilon^{-1/2} \|\mathbf{v}\|_{\mathbf{L}^2(\Gamma)} + |\mathbf{v}|_{\mathbf{H}^1(\Gamma)} \quad \text{for all } \mathbf{v} \in \mathbf{H}^1(D_{\text{in}}).$$

By the multiplicative trace inequality (2.23),

$$\begin{aligned} \varepsilon^{-1} \|\mathbf{v}\|_{\mathbf{L}^2(\Gamma)}^2 &\lesssim \frac{1}{R\varepsilon} \|\mathbf{v}\|_{\mathbf{L}^2(D_{\text{in}})}^2 + \varepsilon^{-1} \|\mathbf{v}\|_{\mathbf{L}^2(D_{\text{in}})} |\mathbf{v}|_{\mathbf{H}^1(D_{\text{in}})} \\ &\lesssim \frac{1}{R\varepsilon} \|\mathbf{v}\|_{\mathbf{L}^2(D_{\text{in}})}^2 + \frac{k}{\varepsilon} \|\mathbf{v}\|_{\mathbf{L}^2(D_{\text{in}})} + \frac{1}{k\varepsilon} |\mathbf{v}|_{\mathbf{H}^1(D_{\text{in}})}^2 \lesssim \frac{1}{k\varepsilon} \left(1 + \frac{1}{kR}\right) k^2 \|\mathbf{v}\|_{\mathbf{L}^2(D_{\text{in}})}^2 + \frac{1}{k\varepsilon} |\mathbf{v}|_{\mathbf{H}^1(D_{\text{in}})}^2, \end{aligned}$$

and then (B.31) follows from the assumption that $kR_0 \gtrsim 1$.

It therefore remains to show that \mathbf{q} exists, is unique, and satisfies the bounds (B.25) and (B.26) for $|\beta| \leq 1$. Given $\mathbf{v} \in \mathbf{H}^2(D_{\text{in}})$ there exist $\mathbf{v}_n \in \mathbf{C}^\infty(\overline{D_{\text{in}}})$ such that $\mathbf{v}_n \rightarrow \mathbf{v}$ in $\mathbf{H}^2(D_{\text{in}})$ as $n \rightarrow \infty$. Let $\mathbf{q}_n \in C^\infty(\overline{D_{\text{in}}}, \mathbf{H}_\#^1(Y))$ be the solution of

$$\nabla_{\mathbf{y}} \times \mathbf{q}_n(\mathbf{x}, \mathbf{y}) = \widehat{\mathbf{M}}(\mathbf{y}) \mathbf{v}_n(\mathbf{x}), \quad \nabla_{\mathbf{y}} \cdot \mathbf{q}_n(\mathbf{x}, \mathbf{y}) = 0,$$

which exists by Lemma B.4. By linearity,

$$\nabla_{\mathbf{y}} \times (\mathbf{q}_n - \mathbf{q}_m)(\mathbf{x}, \mathbf{y}) = \widehat{\mathbf{M}}(\mathbf{y}) (\mathbf{v}_n - \mathbf{v}_m)(\mathbf{x}), \quad \nabla_{\mathbf{y}} \cdot (\mathbf{q}_n - \mathbf{q}_m)(\mathbf{x}, \mathbf{y}) = 0.$$

The definition of the Bochner norm

$$\|\mathbf{q}\|_{H^2(\overline{D_{\text{in}}}, \mathbf{H}_\#^1(Y))}^2 := \sum_{|\beta| \leq 2} \|\partial_{\mathbf{x}}^\beta \mathbf{q}\|_{L^2(\overline{D_{\text{in}}}, \mathbf{H}_\#^1(Y))}^2$$

and the bound (B.23) imply that

$$\|\mathbf{q}_n - \mathbf{q}_m\|_{H^2(\overline{D_{\text{in}}}, \mathbf{H}_\#^1(Y))} \leq \left(1 + \frac{1}{\pi}\right) \|\widehat{\mathbf{M}}\|_{L^\infty(Y)} \|\mathbf{v}_n - \mathbf{v}_m\|_{H^2(\overline{D_{\text{in}}})}$$

for all n, m . Therefore \mathbf{q}_n is Cauchy sequence in $H^2(\overline{D_{\text{in}}}, \mathbf{H}_\#^1(Y))$ and converges to some $\mathbf{q} \in H^2(\overline{D_{\text{in}}}, \mathbf{H}_\#^1(Y))$. By continuity of weak derivative operators, $\nabla_{\mathbf{y}} \times \mathbf{q} = \phi$ and $\nabla_{\mathbf{y}} \cdot \mathbf{q} = 0$ for a. e. $\mathbf{x} \in D_{\text{in}}$. Furthermore, by (B.24),

$$\int_{D_{\text{in}}} \|(\partial_{\mathbf{x}}^\beta \mathbf{q}_n)(\mathbf{x}, \cdot)\|_{L^\infty(Y)}^2 d\mathbf{x} \leq (C_{\text{emb},s})^2 \left(1 + \frac{1}{\pi}\right)^2 \|\widehat{\mathbf{M}}\|_{H^s(Y)}^2 \int_{D_{\text{in}}} |(\partial^\beta \mathbf{v}_n)(\mathbf{x})|^2 d\mathbf{x}$$

and

$$\int_{D_{\text{in}}} \|(\partial_{\mathbf{x}}^\beta (\mathbf{q}_n - \mathbf{q}_m))(\mathbf{x}, \cdot)\|_{L^\infty(Y)}^2 d\mathbf{x} \leq (C_{\text{emb},s})^2 \left(1 + \frac{1}{\pi}\right)^2 \|\widehat{\mathbf{M}}\|_{H^s(Y)}^2 \int_{D_{\text{in}}} |(\partial^\beta (\mathbf{v}_n - \mathbf{v}_m))(\mathbf{x})|^2 d\mathbf{x}$$

for $|\beta| \leq 2$ and $n, m \in \mathbb{N}$. Therefore \mathbf{q}_n is a Cauchy sequence in $H^2(D_{\text{in}}, \mathbf{L}^\infty(Y))$ and

$$\int_{D_{\text{in}}} \|(\partial_{\mathbf{x}}^\beta \mathbf{q})(\mathbf{x}, \cdot)\|_{L^\infty(Y)}^2 d\mathbf{x} \leq (C_{\text{emb},s})^2 \left(1 + \frac{1}{\pi}\right)^2 \|\widehat{\mathbf{M}}\|_{H^s(Y)}^2 \int_{D_{\text{in}}} |(\partial^\beta \mathbf{v})(\mathbf{x})|^2 d\mathbf{x} \quad (\text{B.33})$$

for $|\beta| \leq 2$. The bounds (B.25) and (B.26) for $|\beta| \leq 2$ therefore follow from (B.33) using similar reasoning to in (B.27). \blacksquare

Theorem B.6 Let Γ be $C^{1,1}$. Assume that $u_0 \in H^2(D_{\text{in}})$, $\widehat{\mathbf{M}} \in H_{\sharp}^s(Y) \cap L^\infty(Y)$, for some $s > 0$, and that $\widehat{\mathbf{M}}$ does not depend on y_d . Assume further that $\nabla_{\mathbf{y}} \cdot (\widehat{\mathbf{M}}\mathbf{w}) = 0$ for all $\mathbf{w} \in \mathbb{C}^d$ independent of \mathbf{y} . Then there exists a unique vector potential $\mathbf{q} \in H^1(D_{\text{in}}, \mathbf{H}_{\sharp}^1(Y))$ such that

$$\nabla_{\mathbf{y}} \times \mathbf{q}(\mathbf{x}, \cdot) = \widehat{\mathbf{M}}(\mathbf{y}) \nabla u_0(\mathbf{x}) \quad \text{and} \quad \nabla_{\mathbf{y}} \cdot \mathbf{q}(\mathbf{x}, \cdot) = 0$$

for a.e. $\mathbf{x} \in D_{\text{in}}$. Furthermore,

$$\|(\nabla_{\mathbf{x}} \times \mathbf{q})^\varepsilon\|_{L^2(D_{\text{in}})} \lesssim |u|_{H^2(D_{\text{in}})}, \quad \|\mathbf{q}^\varepsilon \times \boldsymbol{\nu}\|_{L^2(\Gamma)} \lesssim |u_0|_{H^1(\Gamma)}, \quad (\text{B.34})$$

and, if $kR_0 \gtrsim 1$,

$$\|\nabla \times \mathbf{q}^\varepsilon \cdot \boldsymbol{\nu}\|_{\mathbf{H}^{-1/2}(\Gamma)} \lesssim (1 + (k\varepsilon)^{-1/2}) (k\|u_0\|_{H^1(D_{\text{in}})} + \|u_0\|_{H^2(D_{\text{in}})}) \quad (\text{B.35})$$

(where the omitted constants depend on $\|\widehat{\mathbf{M}}\|_{\mathbf{H}^s(Y)}$ and $\|\widehat{\mathbf{M}}\|_{L^\infty(Y)}$).

Proof. By applying Theorem B.5 with $\mathbf{v} = \nabla u_0$, we see that \mathbf{q} exists and the bounds in (B.34), (B.35) hold when $u_0 \in H^3(D_{\text{in}})$. By the density of $H^3(D_{\text{in}})$ in $H^2(D_{\text{in}})$, and the fact that right-hand sides of the bounds (B.34) are controlled by $\|u_0\|_{H^2(D_{\text{in}})}$, \mathbf{q} exists and the bounds in (B.34), (B.35) hold for $u_0 \in H^2(D_{\text{in}})$. \blacksquare

C Bounding $C_{\text{sol}}(\mathbf{A}_\varepsilon, n_\varepsilon, k, R, R_0)$ for kR sufficiently small

As discussed in §1.3.2, in [13, Bottom of Page 2539 and top of Page 2540] $C_{\text{sol}}(\mathbf{A}_\varepsilon, n_\varepsilon, k, R, R_0)$ is assumed to be independent of ε and to only depend on $n_{\text{min}}, n_{\text{max}}, A_{\text{min}}$, and A_{max} . We now show that this is true if kR is sufficiently small.

By [54, Lemma 3.3], given $k_0, R_0 > 0$, there exist $\widetilde{C}_{\text{DtN}} = \widetilde{C}_{\text{DtN}}(k_0 R_0)$ such that

$$-\Re \langle \text{DtN}_k \phi, \phi \rangle_{\Gamma_R} \geq \widetilde{C}_{\text{DtN}} R^{-1} \|\phi\|_{L^2(\Gamma_R)}^2 \quad \text{for all } \phi \in H^{1/2}(\Gamma_R), \quad k \geq k_0, \text{ and } R \geq R_0. \quad (\text{C.1})$$

By, e.g., [87, Corollary A.15], there exists $C_{\text{PF}} = C_{\text{PF}}(\Omega_-)$ ('PF' standing for 'Poincaré–Friedrichs') such that

$$R^{-2} \|v\|_{L^2(B_R)}^2 \leq C_{\text{PF}} \left(R^{-1} \|v\|_{L^2(\Gamma_R)}^2 + \|\nabla v\|_{L^2(B_R)}^2 \right) \quad \text{for all } v \in H^1(B_R). \quad (\text{C.2})$$

Lemma C.1 (Coercivity of $b(\cdot, \cdot)$ for kR sufficiently small) *If*

$$kR \leq \frac{3n_{\text{max}} C_{\text{PF}}}{\min\{A_{\text{min}}, \widetilde{C}_{\text{DtN}}\}}, \quad (\text{C.3})$$

then

$$\Re b(v, v) \geq \frac{\min\{A_{\text{min}}, \widetilde{C}_{\text{DtN}}\}}{2} \|\nabla v\|_{L^2(B_R)}^2 + \frac{n_{\text{max}}}{2} k^2 \|v\|_{L^2(B_R)}^2 \quad \text{for all } v \in H^1(B_R). \quad (\text{C.4})$$

The bound

$$C_{\text{sol}}(\mathbf{A}_\varepsilon, n_\varepsilon, k, R, R_0) \leq \left(\min\left\{ \min\{A_{\text{min}}, \widetilde{C}_{\text{DtN}}\}, n_{\text{max}} \right\} \right)^{-1}$$

under the assumption (C.3) then immediately follows from the Lax–Milgram lemma and the definition of C_{sol} (1.11)

Proof of Lemma C.1. Using the definition of $b(\cdot, \cdot)$ (1.6) and the inequalities (C.1) and (C.2), we have

$$\begin{aligned} \Re b(v, v) &\geq A_{\text{min}} \|\nabla v\|_{L^2(B_R)}^2 - k^2 n_{\text{max}} \|v\|_{L^2(B_R)}^2 + R^{-1} \widetilde{C}_{\text{DtN}} \|v\|_{L^2(\Gamma_R)}^2, \\ &\geq \min\{A_{\text{min}}, \widetilde{C}_{\text{DtN}}\} \left(\|\nabla v\|_{L^2(B_R)}^2 + \frac{1}{R} \|v\|_{L^2(\Gamma_R)}^2 \right) - k^2 n_{\text{max}} \|v\|_{L^2(B_R)}^2, \\ &\geq \frac{\min\{A_{\text{min}}, \widetilde{C}_{\text{DtN}}\}}{2} \left(\|\nabla v\|_{L^2(B_R)}^2 + \frac{1}{R} \|v\|_{L^2(\Gamma_R)}^2 \right) + n_{\text{max}} \left(-1 + \frac{\min\{A_{\text{min}}, \widetilde{C}_{\text{DtN}}\}}{2n_{\text{max}}(kR)^2 C_{\text{PF}}} \right) k^2 \|v\|_{L^2(B_R)}^2, \end{aligned}$$

and the result (C.4) follows. \blacksquare

Acknowledgements. The authors thank Kirill Cherednichenko (University of Bath), Daniel Peterseim (Universität Augsburg), and Barbara Verfürth (KIT) for useful discussions about the homogenisation literature. EAS was supported by EPSRC grant EP/R005591/1.

References

- [1] G. S. Alberti and Y. Capdeboscq. *Lectures on elliptic methods for hybrid inverse problems*. Société Mathématique de France, 2018.
- [2] G. Alessandrini. Strong unique continuation for general elliptic equations in 2D. *Journal of Mathematical Analysis and Applications*, 386(2):669–676, 2012.
- [3] V. M. Babich and V. S. Buldyrev. *Short-Wavelength Diffraction Theory*. Springer-Verlag, Berlin, 1991.
- [4] T. Baden-Riess. PHD Thesis: Existence, Uniqueness & Explicit Bounds for Scattering By Rough Surfaces. *arXiv preprint arXiv:1904.04011*, 2019.
- [5] J. M. Ball, Y. Capdeboscq, and B. Tsering-Xiao. On uniqueness for time harmonic anisotropic Maxwell’s equations with piecewise regular coefficients. *Math. Mod. Meth. App. S.*, 22(11):1250036, 2012.
- [6] H. Barucq, T. Chaumont-Frelet, and C. Gout. Stability analysis of heterogeneous Helmholtz problems and finite element solution based on propagation media approximation. *Math. Comp.*, 86(307):2129–2157, 2017.
- [7] A. Bensoussan, J.-L. Lions, and G. Papanicolaou. *Asymptotic analysis for periodic structures*. American Mathematical Soc., 1978.
- [8] C. O. Bloom. Estimates for solutions of reduced hyperbolic equations of the second order with a large parameter. *Journal of Mathematical Analysis and Applications*, 44(2):310–332, 1973.
- [9] C. O. Bloom and N. D. Kazarinoff. A priori bounds for solutions of the Dirichlet problem for $[\Delta + \lambda^2 n(x)]u = f(x, \lambda)$ on an exterior domain. *Journal of Differential Equations*, 24(3):437–465, 1977.
- [10] G Bouchitté and D. Felbacq. Homogenization near resonances and artificial magnetism from dielectrics. *C. R. Math. Acad. Sci. Paris*, 339(5):377–382, 2004.
- [11] D. L. Brown, D. Gallistl, and D. Peterseim. Multiscale Petrov-Galerkin method for high-frequency heterogeneous Helmholtz equations. In *Meshfree methods for partial differential equations VIII*, pages 85–115. Springer, 2017.
- [12] F. Cakoni and D. Colton. *Qualitative Approach to Inverse Scattering Theory*. Springer, 2014.
- [13] F. Cakoni, B. B. Guzina, and S. Moskow. On the homogenization of a scalar scattering problem for highly oscillating anisotropic media. *SIAM Journal on Mathematical Analysis*, 48(4):2532–2560, 2016.
- [14] Y. Capdeboscq. On the scattered field generated by a ball inhomogeneity of constant index. *Asymptot. Anal.*, 77(3-4):197–246, 2012.
- [15] Y. Capdeboscq, G. Leadbetter, and A. Parker. On the scattered field generated by a ball inhomogeneity of constant index in dimension three. In *Multi-scale and high-contrast PDE: from modelling, to mathematical analysis, to inversion*, volume 577 of *Contemp. Math.*, pages 61–80. Amer. Math. Soc., Providence, RI, 2012.
- [16] J.M. Carcione, D. Kosloff, and A. Behle. Long-wave anisotropy in stratified media: A numerical test. *Geophysics*, 56(2):245–254, 1991.
- [17] F. Cardoso, G. Popov, and G. Vodev. Distribution of resonances and local energy decay in the transmission problem II. *Mathematical Research Letters*, 6:377–396, 1999.
- [18] M.A. Keçebaş and K. Sendur. Enhancing the spectral reflectance of refractory metals by multilayer optical thin-film coatings. *J. Optical Soc. America B*, 35(8):1845–1853, 2018.
- [19] S. N. Chandler-Wilde, I. G. Graham, S. Langdon, and E. A. Spence. Numerical-asymptotic boundary integral methods in high-frequency acoustic scattering. *Acta Numerica*, 21(1):89–305, 2012.
- [20] S. N. Chandler-Wilde, D. P. Hewett, and A. Moiola. Interpolation of Hilbert and Sobolev spaces: quantitative estimates and counterexamples. *Mathematika*, 61:414–443, 2015.
- [21] S. N. Chandler-Wilde and P. Monk. Wave-number-explicit bounds in time-harmonic scattering. *SIAM J. Math. Anal.*, 39(5):1428–1455, 2008.
- [22] S. N. Chandler-Wilde, E. A. Spence, A. Gibbs, and V. P. Smyshlyaev. High-frequency bounds for the helmholtz equation under parabolic trapping and applications in numerical analysis. *SIAM Journal on Mathematical Analysis*, 52(1):845–893, 2020.
- [23] T. Chaumont Frelet. *Approximation par éléments finis de problèmes d’Helmholtz pour la propagation d’ondes sismiques*. PhD thesis, Rouen, INSA, 2015.
- [24] T. Chaumont-Frelet. On high order methods for the heterogeneous Helmholtz equation. *Computers & Mathematics with Applications*, 72(9):2203–2225, 2016.
- [25] T. Chaumont-Frelet and S. Nicaise. Wavenumber explicit convergence analysis for finite element discretizations of general wave propagation problem. *IMA J. Numer. Anal.*, 40(2):1503–1543, 2020.
- [26] T. Chaumont-Frelet and F. Valentin. A multiscale hybrid-mixed method for the Helmholtz equation in heterogeneous domains. *SIAM Journal on Numerical Analysis*, 58(2):1029–1067, 2020.

- [27] D. Cioranescu and P. Donato. *An introduction to homogenization*. Oxford University Press, 1999.
- [28] M. Costabel, M. Dauge, and S. Nicaise. Singularities of Maxwell interface problems. *ESAIM Math. Model. Numer. Anal.*, 33(3):627–649, 1999.
- [29] L. C. Evans. *Partial differential equations*. American Mathematical Society Providence, RI, 1998.
- [30] J. Fang, J. Qian, L. Zepeda-Núñez, and H. Zhao. A hybrid approach to solve the high-frequency Helmholtz equation with source singularity in smooth heterogeneous media. *J. Comp. Phys.*, 371:261–279, 2018.
- [31] N. Filonov. Second-order elliptic equation of divergence form having a compactly supported solution. *Journal of Mathematical Sciences*, 106(3):3078–3086, 2001.
- [32] J. Galkowski, E. A. Spence, and J. Wunsch. Optimal constants in nontrapping resolvent estimates. *Pure and Applied Analysis*, 2(1):157–202, 2020.
- [33] M. Ganesh and C. Morgenstern. A coercive heterogeneous media Helmholtz model: formulation, wavenumber-explicit analysis, and preconditioned high-order FEM. *Numerical Algorithms*, pages 1–47, 2019.
- [34] N. Garofalo and F.-H. Lin. Unique continuation for elliptic operators: A geometric-variational approach. *Communications on Pure and Applied Mathematics*, 40(3):347–366, 1987.
- [35] V. Girault and P.-A. Raviart. *Finite element methods for Navier-Stokes equations: theory and algorithms*. Springer Science & Business Media, 1986.
- [36] S. Gong, I. G. Graham, and E. A. Spence. Domain decomposition preconditioners for high-order discretisations of the heterogeneous Helmholtz equation. *IMA J. Num. Anal.*, 41(3):2139–2185, 2021.
- [37] L. Grafakos. *Classical Fourier Analysis*. Number 249 in Graduate Texts in Mathematics. Springer, 2008.
- [38] I. G. Graham, O. R. Pembrey, and E. A. Spence. The Helmholtz equation in heterogeneous media: a priori bounds, well-posedness, and resonances. *Journal of Differential Equations*, 266(6):2869–2923, 2019.
- [39] I. G. Graham and S. Sauter. Stability and finite element error analysis for the Helmholtz equation with variable coefficients. *Math. Comp.*, 89(321):105–138, 2020.
- [40] G. Griso. Error estimate and unfolding for periodic homogenization. *Asymptotic Analysis*, 40(3, 4):269–286, 2004.
- [41] G. Griso. Interior error estimate for periodic homogenization. *Analysis and Applications*, 4(01):61–79, 2006.
- [42] P. Grisvard. *Elliptic problems in nonsmooth domains*. Pitman, Boston, 1985.
- [43] L. Hörmander. Uniqueness theorems and estimates for normally hyperbolic partial differential equations of the second order. *CR du douzième congrès des mathématiciens scandinaves*, pages 105–115, 1953.
- [44] L. Hörmander. *The analysis of linear partial differential operators III: pseudo-differential operators*. Springer, 1985.
- [45] D. Jerison and C. E. Kenig. Unique continuation and absence of positive eigenvalues for Schrödinger operators. *Annals of Mathematics*, 121(3):463–488, 1985.
- [46] V. V. Jikov, S. M. Kozlov, and O. A. Oleinik. *Homogenization of differential operators and integral functionals*. Springer Science & Business Media, 2012.
- [47] J. L. Kazdan. Unique continuation in geometry. *Comm. Pure Appl. Math*, 41(5):667–681, 1988.
- [48] C. Kenig, F. Lin, and Z. Shen. Homogenization of elliptic systems with Neumann boundary conditions. *Journal of the American Mathematical Society*, 26(4):901–937, 2013.
- [49] C. Kenig, F. Lin, and Z. Shen. Periodic homogenization of Green and Neumann functions. *Communications on Pure and Applied Mathematics*, 67(8):1219–1262, 2014.
- [50] D. Lafontaine, E. A. Spence, and J. Wunsch. Wavenumber-explicit convergence of the *hp*-FEM for the full-space heterogeneous Helmholtz equation with smooth coefficients. *arXiv preprint arXiv:2010.00585*, 2020.
- [51] D. Lafontaine, E. A. Spence, and J. Wunsch. Decompositions of high-frequency Helmholtz solutions via functional calculus, and application to the finite element method. *arXiv preprint arXiv:2102.13081*, 2021.
- [52] H. Liu, L. Rondi, and J. Xiao. Mosco convergence for $H(\text{curl})$ spaces, higher integrability for Maxwell’s equations, and stability in direct and inverse EM scattering problems. *Journal of the European Mathematical Society*, 21(10):2945–2993, 2019.
- [53] W. McLean. *Strongly elliptic systems and boundary integral equations*. Cambridge University Press, 2000.
- [54] J. M. Melenk and S. Sauter. Convergence analysis for finite element discretizations of the Helmholtz equation with Dirichlet-to-Neumann boundary conditions. *Math. Comp*, 79(272):1871–1914, 2010.
- [55] R. Melrose and M. Taylor. Boundary problems for wave equations with grazing and gliding rays. *preprint*. <http://mtaylor.web.unc.edu/files/2018/04/glide.pdf>.
- [56] R. B. Melrose and J. Sjöstrand. Singularities of boundary value problems. I. *Communications on Pure and Applied Mathematics*, 31(5):593–617, 1978.
- [57] R. B. Melrose and J. Sjöstrand. Singularities of boundary value problems. II. *Communications on Pure and Applied Mathematics*, 35(2):129–168, 1982.
- [58] L. Miller. Refraction of high-frequency waves density by sharp interfaces and semiclassical measures at the boundary. *J. Math. Pures Appl. (9)*, 79(3):227–269, 2000.

- [59] A. Moiola and E. A. Spence. Acoustic transmission problems: wavenumber-explicit bounds and resonance-free regions. *Math. Mod. Meth. App. S.*, 29(2):317–354, 2019.
- [60] P. Monk. *Finite element methods for Maxwell’s equations*. Oxford University Press, 2003.
- [61] C. S. Morawetz. The decay of solutions of the exterior initial-boundary value problem for the wave equation. *Communications on Pure and Applied Mathematics*, 14(3):561–568, 1961.
- [62] C. S. Morawetz. Decay for solutions of the exterior problem for the wave equation. *Comm. Pure Appl. Math.*, 28(2):229–264, 1975.
- [63] C. S. Morawetz and D. Ludwig. An inequality for the reduced wave operator and the justification of geometrical optics. *Comm. Pure Appl. Math.*, 21:187–203, 1968.
- [64] S. Moskow and M. Vogelius. First-order corrections to the homogenised eigenvalues of a periodic composite medium. A convergence proof. *Proc. Roy. Soc. Edin. A.*, 127(6):1263–1299, 1997.
- [65] S. Moskow and M. Vogelius. First order corrections to the homogenized eigenvalues of a periodic composite medium. The case of Neumann boundary conditions. *Technical report*, 1997.
- [66] J. C. Nédélec. *Acoustic and electromagnetic equations: integral representations for harmonic problems*. Springer Verlag, 2001.
- [67] M. Ohlberger and B. Verfürth. A new heterogeneous multiscale method for the helmholtz equation with high contrast. *Multiscale Modeling & Simulation*, 16(1):385–411, 2018.
- [68] D. Onofrei and B. Vernescu. Error estimates for periodic homogenization with non-smooth coefficients. *Asymptotic Analysis*, 54(1-2):103–123, 2007.
- [69] L. E. Payne and H. F. Weinberger. New bounds for solutions of second order elliptic partial differential equations. *Pacific Journal of Mathematics*, 8(3):551–573, 1958.
- [70] O. R. Pembro. *The Helmholtz Equation in Heterogeneous and Random Media: Analysis and Numerics*. PhD thesis, University of Bath, 2020.
- [71] D. Peterseim and B. Verfürth. Computational high frequency scattering from high-contrast heterogeneous media. *Mathematics of Computation*, 89:2649–2674, 2020.
- [72] G. Popov and G. Vodev. Distribution of the resonances and local energy decay in the transmission problem. *Asymptotic Analysis*, 19(3-4):253–265, 1999.
- [73] G. Popov and G. Vodev. Resonances near the real axis for transparent obstacles. *Communications in Mathematical Physics*, 207(2):411–438, 1999.
- [74] J. V. Ralston. Trapped rays in spherically symmetric media and poles of the scattering matrix. *Communications on Pure and Applied Mathematics*, 24(4):571–582, 1971.
- [75] F. Rellich. Darstellung der Eigenwerte von $\Delta u + \lambda u = 0$ durch ein Randintegral. *Mathematische Zeitschrift*, 46(1):635–636, 1940.
- [76] F. Rellich. Über das asymptotische Verhalten der Lösungen von $\Delta u + \lambda u = 0$ in unendlichen Gebieten. *Jahresbericht der Deutschen Mathematiker-Vereinigung*, 53:57–65, 1943.
- [77] W. Rudin. *Real and complex analysis*. McGraw-Hill, 3rd edition, 1986.
- [78] S. Sauter and C. Torres. Stability estimate for the Helmholtz equation with rapidly jumping coefficients. *Zeitschrift für angewandte Mathematik und Physik*, 69(6):139, 2018.
- [79] S. Sauter and C. Torres. The Heterogeneous Helmholtz Problem with Spherical Symmetry: Green’s Operator and Stability Estimates. *arXiv preprint arXiv:2006.15866*, 2020.
- [80] A. Semin, B. Delourme, and K. Schmidt. On the homogenization of the Helmholtz problem with thin perforated walls of finite length. *ESAIM: Mathematical Modelling and Numerical Analysis*, 52(1):29–67, 2018.
- [81] E. A. Spence. Wavenumber-explicit bounds in time-harmonic acoustic scattering. *SIAM Journal on Mathematical Analysis*, 46(4):2987–3024, 2014.
- [82] E. A. Spence. Overview of Variational Formulations for Linear Elliptic PDEs. In A. S. Fokas and B. Pelloni, editors, *Unified transform method for boundary value problems: applications and advances*, pages 93–159. SIAM, 2015.
- [83] E. A. Spence, S. N. Chandler-Wilde, I. G. Graham, and V. P. Smyshlyaev. A new frequency-uniform coercive boundary integral equation for acoustic scattering. *Comm. Pure Appl. Math.*, 64(10):1384–1415, 2011.
- [84] P. Stefanov. Resonances near the real axis imply existence of quasimodes. *Comptes Rendus de l’Académie des Sciences-Series I-Mathematics*, 330(2):105–108, 2000.
- [85] T. Suslina. Homogenization of the Neumann problem for elliptic systems with periodic coefficients. *SIAM Journal on Mathematical Analysis*, 45(6):3453–3493, 2013.
- [86] M. Thomas. *Analysis of Rough Surface Scattering Problems*. PhD thesis, University of Reading, 2006.
- [87] A. Toselli and O. Widlund. *Domain Decomposition Methods: Algorithms and Theory*. Springer, 2005.
- [88] S. Upendar, R.F. Ando, M.A. Schmidt, and T. Weiss. Orders of magnitude loss reduction in photonic bandgap fibers by engineering the core surround. *Optics express*, 29(6):8606–8616, 2021.
- [89] T. H. Wolff. A property of measures in \mathbb{R}^N and an application to unique continuation. *Geometric & Functional Analysis*, 2(2):225–284, 1992.
- [90] V. V. Zhikov and S. E. Pastukhova. On operator estimates for some problems in homogenization theory. *Russian Journal of Mathematical Physics*, 12(4):515–524, 2005.
- [91] M. Zworski. *Semiclassical analysis*, volume 138 of *Graduate Studies in Mathematics*. American Mathematical Society, Providence, RI, 2012.