



**HAL**  
open science

# Equivalence of Linear Complementarity Problems: Theory and Application to Nonsmooth Bifurcations

Felix Miranda-Villatoro, Fernando Castaños, Alessio Franci

► **To cite this version:**

Felix Miranda-Villatoro, Fernando Castaños, Alessio Franci. Equivalence of Linear Complementarity Problems: Theory and Application to Nonsmooth Bifurcations. 2021. hal-03319638v1

**HAL Id: hal-03319638**

**<https://inria.hal.science/hal-03319638v1>**

Preprint submitted on 13 Aug 2021 (v1), last revised 21 Mar 2023 (v2)

**HAL** is a multi-disciplinary open access archive for the deposit and dissemination of scientific research documents, whether they are published or not. The documents may come from teaching and research institutions in France or abroad, or from public or private research centers.

L'archive ouverte pluridisciplinaire **HAL**, est destinée au dépôt et à la diffusion de documents scientifiques de niveau recherche, publiés ou non, émanant des établissements d'enseignement et de recherche français ou étrangers, des laboratoires publics ou privés.

# Equivalence of Linear Complementarity Problems: Theory and Application to Nonsmooth Bifurcations

Félix A. Miranda-Villatoro, Fernando Castaños, *Member, IEEE*, and Alessio Franci

**Abstract**—Linear complementarity problems provide a powerful framework to model nonsmooth phenomena in a variety of real-world applications. In dynamical control systems, they appear coupled to a linear input-output system in the form of linear complementarity systems. Mimicking the program that led to the foundation of bifurcation theory in smooth maps, we introduce a novel notion of equivalence between linear complementarity problems that sets the basis for a theory of bifurcations in a large class of nonsmooth maps, including, but not restricted to, steady-state bifurcations in linear complementarity systems. Our definition exploits the rich geometry of linear complementarity problems and leads to constructive algebraic conditions for identifying and classifying the nonsmooth singularities associated with nonsmooth bifurcations. We thoroughly illustrate our theory on an extended applied example, the design of bistability in an electrical network, and a more theoretical one, the identification and classification of all possible equivalence classes in two-dimensional linear complementarity problems.

**Index Terms**—Bifurcations, linear complementarity problems, nonsmooth dynamics, piecewise linear equations.

## I. INTRODUCTION

COMPLEMENTARITY conditions emerge naturally in a variety of contexts, from economics to engineering, from operations research to optimization. Electrical networks with semiconductor devices [1]–[3], mechanical systems with unilateral constraints [4], price equilibrium, traffic network [5], and portfolio selection problems [6] can all be modeled using a formalism in which decision variables must satisfy a set of complementarity conditions. Linear complementarity problems (LCPs) are nonsmooth problems in which a set of complementarity conditions is coupled with a set of linear relations among the problem variables. Due to the broad spectrum of applications, complementarity problems (and LCPs in

particular) have been extensively studied, see, e.g., [7]–[12] and references therein. Complementarity problems appear in nonlinear control theory in the form of linear complementarity systems (LCSs), which are defined by coupling a set of complementarity conditions to a linear input–output control system, see, e.g., [13]–[16].

Because of their nonlinear nature, LCSs can undergo bifurcations at which equilibria, limit cycles, or other types of steady-state solutions appear, disappear, or change stability. From a control-theoretical perspective, knowing which bifurcations can occur in a controlled system is instrumental for two complementary reasons. Suppose the control objective is to preserve the stability of a desired set point. In that case, bifurcations must be avoided, and knowing the types of bifurcation that the system can undergo guides the design of stabilizing control laws [17]–[21]. On the other hand, if the goal is to design rich nonlinear temporal and distributed behaviors, then bifurcations must be sought because, in their vicinity, the nonlinear behavior can be modulated with enhanced sensitivity. This second use of bifurcations in control systems has been explored in [22]–[24] for the design of neuro-inspired control systems and in [25]–[28] for the design of bio-inspired collective decision making in multi-agent systems.

As opposed to smooth bifurcation theory, a nonsmooth bifurcation theory for LCSs is entirely undeveloped. Here, we elaborate on our preliminary results [29] and introduce novel theoretical tools to analyze and design the possible ways in which the set of solutions to an LCP changes as a function of control and system parameters. We propose these tools as candidates for the development of a nonsmooth bifurcation theory for LCSs.

The first contribution of our paper is to show that steady-state bifurcations (i.e., those bifurcations solely involving equilibrium points) of an LCS are fully characterized by the (nonsmooth) singularities of an auxiliary LCP. The definition of the auxiliary LCP depends both on the linear part and on the complementarity conditions of the LCS. The problem of analyzing, classifying, and detecting steady-state bifurcation in LCSs thus reduces to the problem of analyzing, classifying, and detecting nonsmooth singularities in LCPs.

The second main contribution of our paper is the introduction of a notion of equivalence between LCPs. Various notions of equivalence between vector fields are at the basis of smooth bifurcation theory in its different flavors [30]–

This paragraph of the first footnote will contain the date on which you submitted your paper for review. It will also contain support information, including sponsor and financial support acknowledgment. For example, “This work was supported in part by the U.S. Department of Commerce under Grant BS123456.”

Félix A. Miranda-Villatoro is with the Univ. Grenoble-Alpes, INRIA, CNRS, LJK, Grenoble INP, 38000 Grenoble, France (e-mail: felix.miranda-villatoro@inria.fr).

Fernando Castaños is with the Departamento de Control Automático, CINVESTAV-IPN, 2508 Av. IPN, 07360, Mexico City, Mexico (e-mail: fernando.castanos@cinvestav.mx).

Alessio Franci is with the Departamento de Matemáticas, Universidad Autónoma de México, Circuito exterior S/N, C.U., 04510. Mexico City, Mexico (e-mail: afranci@ciencias.unam.mx).

[32]. In line with the smooth theory, we declare two LCPs to be equivalent if one can be transformed into the other by suitable coordinate changes. Roughly speaking, according to our definition, two LCPs are equivalent if the geometry of their solution space is the same, in the sense that regular (singular) solutions to the first LCP can be put in one-to-one correspondence with regular (singular) solutions to the second LCP via a homeomorphism. Crucially, this notion of equivalence allows us to characterize which LCPs are *LCP-stable*, i.e., those LCPs for which the geometry of the solution space is not destroyed by perturbations. This class of LCPs is particularly relevant in a control-theoretical setting because an associated LCS inherits this robustness.

Again in line with the smooth theory, the coordinate transformations defining our notion of LCP-equivalence are required to be continuous, i.e., they are topological isomorphisms. However, topological equivalence alone turns out to be too crude a concept in the LCP setting. This is akin to the situation in smooth singularity theory where, for having a meaningful notion of equivalence, additional structure (smoothness) is imposed on the coordinate transformations. The intrinsic nonsmoothness of LCPs places these problems at a different stage, so a novel framework is required. It has long been recognized that the so-called complementary cones associated with an LCP play a central role in their analysis and reflect its rich geometric structure. Thus, the additional restriction we impose on the coordinate transformations is to preserve the Boolean algebra generated by the complementary cones. The proposed equivalence relation proves to be a powerful framework for the analysis, classification, and design of LCPs and LCSs.

The applicability of our theory is illustrated in two extended examples. In the first (more applied) example, we consider the LCS associated with a general electrical circuit with two transistors in feedback interconnection. It is known that this circuit is essential to achieve negative resistance and thus bistability and switches [33], but a rigorous and constructive characterization of its steady states has remained elusive. Our theory allows us to derive constructive and rigorous conditions to ensure LCP-stability, and thus robustness to disturbances and parametric uncertainties of the circuit, and ensure bistability of its input-output behavior. In the second (more theoretical) example, we provide an exhaustive classification of two-dimensional LCPs. Inspired by the concept of organizing center in smooth singularity theory, we derive the classification by first characterizing two-dimensional LCP-unstable complementarity problems and then characterizing the open complement of this unstable set.

The manuscript is organized in the following way: Section II introduces the notation used in this work, whereas linear complementarity problems and useful properties are recalled in Section III. Section IV motivates the proposed framework of LCP-equivalence in the context of LCSs. Afterward, Sections V and VI constitute the main body of the paper, where the notions of LCP-equivalence and LCP-stability are studied, and the main results are presented. Subsequently, the proposed framework is applied in Section VII to the design of bistable LCSs and in Section VIII to the classification of LCPs.

## II. NOTATION

Let  $X$  be a non-empty set. The power set of  $X$  is denoted as  $\mathcal{P}(X)$ . Whenever  $X$  is finite,  $|X|$  denotes its cardinality. For a set  $Y \subset X$ ,  $Y^c$  denotes its complement in  $X$ ,  $Y^c := X \setminus Y$ . The notations  $\text{int } Y$ ,  $\text{bdr } Y$  and  $\text{cl } Y$  stand for the interior, the boundary and the closure of  $Y$ , respectively.

Given an integer  $n$ , we use  $[1 \dots n]$  to denote the interval of all integers between 1 and  $n$ . We endow all subsets of  $\mathbb{N}$  with the natural order. Let  $A \in \mathbb{R}^{n \times m}$ ,  $\alpha \subseteq [1 \dots n]$ , and  $\beta \subseteq [1 \dots m]$ . The submatrix  $A_{\alpha, \beta} \in \mathbb{R}^{|\alpha| \times |\beta|}$  is the matrix  $[A_{ij}]_{i \in \alpha, j \in \beta}$ . The notation  $A_{\cdot, \beta}$  stands for the submatrix  $A_{[1 \dots n], \beta}$ . We omit the braces whenever  $\beta$  is a singleton, that is,  $A_{\cdot, j} = A_{\cdot, \{j\}}$ . The (polyhedral) cone generated by  $A$  is the set of all positive linear combinations of the columns of  $A$ , that is,

$$\text{pos } A := \left\{ x \in \mathbb{R}^n \mid x = \sum_{j=1}^m p_j A_{\cdot, j}, \right. \\ \left. p_j \geq 0, j \in [1 \dots m] \right\}.$$

The columns of  $A$  are the *generators* of  $\text{pos } A$ . The cone  $\text{pos } A$  is said to be *pointed* if there is no non-trivial subspace contained in it, whereas it is said to be *strictly pointed* if  $\ker(A) \cap \mathbb{R}_+^n = \{0\}$ , where

$$\mathbb{R}_+^m := \{x \in \mathbb{R}^m \mid x_i \geq 0, i \in [1 \dots m]\}$$

denotes the positive orthant of  $\mathbb{R}^m$  and  $\ker(A)$  is the null space of  $A$ . Finally, we denote the projection of  $x \in \mathbb{R}^n$  onto the positive orthant  $\mathbb{R}_+^n$  by  $[x]^+$ , that is,

$$[x]^+ := \arg \min_{w \in \mathbb{R}_+^n} \frac{1}{2} \|x - w\|^2.$$

## III. THE LINEAR COMPLEMENTARITY PROBLEM

We start with a brief introduction to the LCP and its geometric properties. We also recall some equivalent formulations that will be useful in the sequel.

*Definition 1:* Given a matrix  $M \in \mathbb{R}^{n \times n}$  and a vector  $q \in \mathbb{R}^n$ , the *linear complementarity problem*  $\text{LCP}(M, q)$  consists in finding a vector  $z \in \mathbb{R}^n$  such that

$$\mathbb{R}_+^n \ni Mz + q \perp z \in \mathbb{R}_+^n. \quad (1)$$

Condition (1) is called the complementarity condition, it is the compact form of the following three conditions: 1)  $Mz + q \in \mathbb{R}_+^n$ ; 2)  $z \in \mathbb{R}_+^n$ ; and 3)  $(Mz + q)^\top z = 0$ .

Linear complementarity problems have a rich geometric structure that determines the properties of their solution set. In what follows, we introduce the necessary elements for the geometric analysis of LCPs.

*Definition 2:* Given an  $\text{LCP}(M, q)$  and a subset  $\alpha \subseteq [1 \dots n]$ . The *complementary matrix*  $C_M(\alpha) \in \mathbb{R}^{n \times n}$  is the matrix whose columns are

$$C_M(\alpha)_{\cdot, j} = \begin{cases} -M_{\cdot, j} & j \in \alpha \\ I_{\cdot, j} & j \notin \alpha \end{cases}. \quad (2)$$

The cone generated by  $C_M(\alpha)$ ,  $\text{pos } C_M(\alpha)$ , is called a *complementary cone* of  $M$ .

A *facet* of  $\text{pos } C_M(\alpha)$  is an  $(n-1)$ -dimensional face of the form  $\text{pos } C_M(\alpha)_{,i^c}$  for some  $i \in [1 \dots n]$  and  $i^c$  the complement of  $\{i\}$  in  $[1 \dots n]$ . In what follows,  $\mathcal{K}(M)$  denotes the union of all facets of the complementary cones of  $M \in \mathbb{R}^{n \times n}$ .

The complementary cone  $\text{pos } C_M(\alpha)$  is called *non-degenerate* if it is solid, that is, if  $C_M(\alpha)$  is nonsingular. Otherwise,  $\text{pos } C_M(\alpha)$  is called *degenerate*.

*Definition 3:* A matrix  $M \in \mathbb{R}^{n \times n}$  is said to be *non-degenerate* if all its complementary cones,  $\text{pos } C_M(\alpha)$ ,  $\alpha \subseteq [1 \dots n]$  are non-degenerate.

*Definition 4 ([34], [35]):* We say that  $M \in \mathbb{R}^{n \times n}$  belongs to the class  $R_0$  if, for each  $\alpha \subseteq [1 \dots n]$ , we have  $\ker(C_M(\alpha)) \cap \mathbb{R}_+^n = \{0\}$ .

The previous definition implies that all the complementary cones are strictly pointed, that is, that  $M$  does not have zero columns nor complementary cones that are subspaces [12, Thm. 6.1.19].

Now we define the piecewise linear map  $f_M : \mathbb{R}^n \rightarrow \mathbb{R}^n$  as

$$f_M(x) := C_{-M}(\alpha)x \text{ for } x \in \text{pos } C_I(\alpha). \quad (3)$$

Note that the cones  $\text{pos } C_I(\alpha)$  are simply the  $2^n$  orthants in  $\mathbb{R}^n$  indexed by  $\alpha \subseteq [1 \dots n]$ , and that

$$f_M(\text{pos } C_I(\alpha)) = \text{pos } C_M(\alpha). \quad (4)$$

*Theorem 1 ([12]):* Let  $z \in \mathbb{R}_+^n$  be a solution to the LCP( $M, q$ ). Then,  $x = (M - I_n)z + q$  is a solution to the equation

$$f_M(x) - q = 0 \quad (5)$$

Conversely, if  $x \in \mathbb{R}^n$  is a solution to (5), then  $z = [-x]^+$  is a solution to the LCP( $M, q$ ).

It follows that the LCP( $M, q$ ) and the problem (5) are equivalent in the sense that we only need to know the solutions to one of them in order to know the solutions to the other.

The functional representation (5) lends itself to the application of degree theory.

*Definition 5:* Let  $M \in \mathbb{R}^{n \times n}$  be an  $R_0$ -matrix and  $x \in \mathbb{R}^n$  be in the interior of  $\text{pos } C_I(\alpha)$  for some  $\alpha \subseteq [1 \dots n]$ . The *index* of  $f_M$  at  $x$ , denoted as  $\text{ind}_M(x)$ , is given by

$$\text{ind}_M(x) = \text{sgn}(\det M_{\alpha,\alpha}).$$

By convention, if  $\alpha = \emptyset$ , then  $\text{ind}_M(x) = 1$ .

*Definition 6:* Let  $M \in \mathbb{R}^{n \times n}$  be an  $R_0$ -matrix and let  $q \in \mathbb{R}^n$  be such that  $f_M^{-1}(q)$  consists of finitely many points and  $\text{ind}_M(x)$  is well-defined for all  $x \in f_M^{-1}(q)$ . The *degree* of  $f_M$  at  $q$ , denoted as  $\text{deg}_M(q)$  is

$$\text{deg}_M(q) = \sum_{x \in f_M^{-1}(q)} \text{ind}_M(x).$$

Note that, for a given  $\alpha \subseteq [1 \dots n]$ , the index of  $f_M$  at  $x$  is the same for all  $x \in \text{int } \text{pos } C_I(\alpha)$  so, there are as many indices as there are subsets in  $[1 \dots n]$ . For matrices in the class  $R_0$ , the degree is the same for any  $q \notin \mathcal{K}(M)$  [12, Theorem 6.1.14]. Thus, for  $R_0$ -matrices the degree is global and one only needs to test one point  $q \notin \mathcal{K}(M)$ . The reader is addressed to [12], [36], [37] and references therein for a detailed account of degree theory in the context of complementarity problems.

The solutions to the LCP( $M, q$ ) depend on the geometry of the complementary cones  $\text{pos } C_M(\alpha)$ . More precisely, there exists at least one solution  $x$  of (3) for every  $\alpha \subseteq [1 \dots n]$  such that  $q \in \text{pos } C_M(\alpha)$ . If  $C_M(\alpha)$  is nonsingular the associated solution is unique, whereas there exists a continuum of solutions if  $C_M(\alpha)$  is singular. Thus, for a given  $q$ , there can be no solutions, there can be one solution, multiple isolated solutions, or a continuum of solutions, depending on how many complementary cones  $q$  belongs to and what the properties of these cones are.

We will later make use of an alternative representation of  $f_M$ .

*Lemma 1:* The map (3) can also be written as

$$f_M(x) = [x]^+ - M[-x]^+. \quad (6)$$

*Proof:* It follows from (2) that, for  $x \in \text{pos } C_I(\alpha)$ , we have  $x_j \leq 0$  if  $j \in \alpha$ , whereas  $x_j \geq 0$  if  $j \notin \alpha$ . Then, equation (3) can be written as

$$\begin{aligned} f_M(x) &= \sum_{j=1}^n C_{-M}(\alpha)_{,j} x_j = \sum_{j \notin \alpha} I_{,j} x_j + \sum_{j \in \alpha} M_{,j} x_j \\ &= \sum_{j=1}^n I_{,j} [x_j]^+ - \sum_{j=1}^n M_{,j} [-x_j]^+, \end{aligned}$$

from which (6) follows directly. ■

#### IV. BIFURCATIONS IN LINEAR COMPLEMENTARITY SYSTEMS

We are interested in LCSs of the form

$$\dot{\xi}(t) = A\xi(t) + Bz(t) + E_1 r \quad (7a)$$

$$w(t) = C\xi(t) + Dz(t) + E_2 s, \quad (7b)$$

$$\mathbb{R}_+^m \ni w(t) \perp z(t) \in \mathbb{R}_+^m \quad (7c)$$

where  $\xi(t) \in \mathbb{R}^n$  is the state of the system at time  $t$ ,  $z(t)$ ,  $w(t) \in \mathbb{R}^m$  are the so-called complementary variables (they can be interpreted as external port variables), and  $r \in \mathbb{R}^l$ ,  $s \in \mathbb{R}^l$  are vectors of parameters. The matrices  $A, B, C, D, E_1$  and  $E_2$  are constant and of appropriate dimensions. Allow us to provide an example.

##### A. LCS model of a circuit with bipolar transistors

Motivated by the work of Chua *et al.* on negative resistance devices [33], we consider the circuit in Fig. 1. The circuit topology is fairly general as, by opening or short-circuiting some of the resistors, it is possible to recover many of the circuits considered in [33].

The circuit contains two bipolar junction transistors (BJTs) that we describe using a dynamical version of the Ebers-Moll model depicted in Fig. 2 (see, e.g., [38]), where each capacitor models the charge storage effects of the P-N and N-P junctions.

Each diode in Fig. 2 satisfies the complementarity condition

$$0 \leq I_d \perp V^* - V_d \geq 0,$$

where  $I_d$  is the current flowing through the diode,  $V_d$  is the voltage across its terminals, and  $V^*$  is the forward voltage of

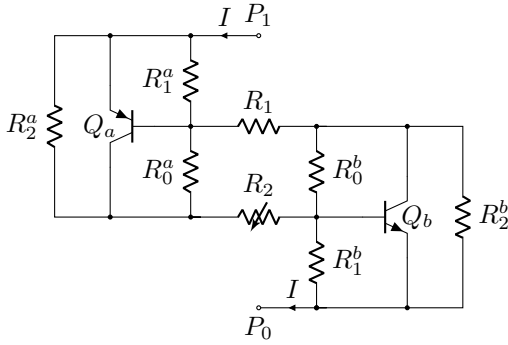

Fig. 1. Feedback interconnection of PNP and NPN transistors showing differential negative resistance between terminals  $P_1$  and  $P_0$ .

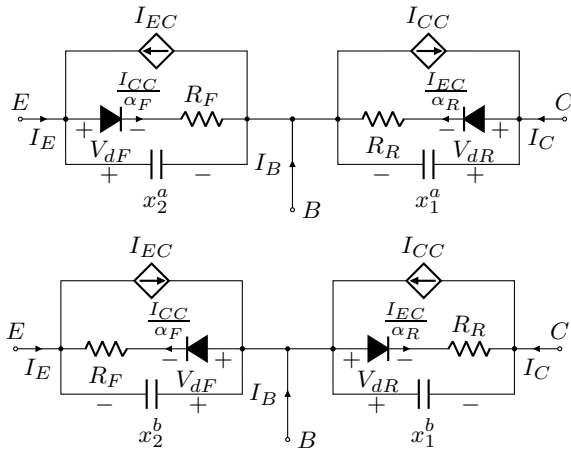

Fig. 2. Ebers-Moll model of bipolar junction transistors. PNP transistor (above), and NPN transistor (below).

the diode (typically between 0.3 V–0.7 V). After the application of Kirchhoff's laws, we realize that the circuit evolves according to (7a)–(7c) with state  $\xi = [x_1^a, x_2^a, x_1^b, x_2^b]^T \in \mathbb{R}^4$ . Here,  $x_k^a$  and  $x_k^b$ ,  $k \in \{1, 2\}$ , are the voltages across the capacitors of the transistors  $Q_a$  and  $Q_b$ , respectively (see Fig. 2). The complementary variables are given by  $z = [I_{EC}^a, I_{CC}^a, I_{EC}^b, I_{CC}^b] \in \mathbb{R}^4$  and  $w = [V^* - V_{dR}^a, V^* - V_{dF}^a, V^* - V_{dR}^b, V^* - V_{dF}^b]^T \in \mathbb{R}^4$ . We have the parameters  $s = V^*$  and  $r = P_1 - P_0$ , the latter being the potential difference across the terminals shown in Fig. 1. The remaining parameters are

$$\begin{aligned} A &= Q \begin{bmatrix} A_{1,1} & A_{1,2} \\ A_{1,2}^T & A_{2,2} \end{bmatrix}, \quad B = Q \begin{bmatrix} T & 0 \\ 0 & T \end{bmatrix}, \\ E_1 &= Q[-G_2, G_1 + G_2, -G_1, G_1 + G_2]^T, \quad E_2 = \mathbf{1}_4, \\ Q &= \text{Diag} \left( \frac{1}{C_1^a}, \frac{1}{C_2^a}, \frac{1}{C_1^b}, \frac{1}{C_2^b} \right), \quad C = -I_4, \\ D &= \text{Diag} \left( \frac{R_R}{\alpha_R}, \frac{R_F}{\alpha_F}, \frac{R_R}{\alpha_R}, \frac{R_F}{\alpha_F} \right), \end{aligned} \quad (8)$$

where  $\mathbf{1}_4 \in \mathbb{R}^4$  is a vector of ones and

$$\begin{aligned} A_{1,1} &= \begin{bmatrix} -(G_0^a + G_2^a + G_2) & G_2^a + G_2 \\ G_2^a + G_2 & -(G_1^a + G_2^a + G_1 + G_2) \end{bmatrix}, \\ A_{2,2} &= \begin{bmatrix} -(G_0^b + G_2^b + G_1) & G_2^b + G_1 \\ G_2^b + G_1 & -(G_1^b + G_2^b + G_1 + G_2) \end{bmatrix}, \\ A_{1,2} &= \begin{bmatrix} 0 & G_2 \\ G_1 & -(G_1 + G_2) \end{bmatrix}, \quad T = \begin{bmatrix} -\frac{1}{\alpha_R} & 1 \\ 1 & -\frac{1}{\alpha_F} \end{bmatrix}, \end{aligned} \quad (9)$$

with  $G_k^j = 1/R_k^j$ ,  $k \in \{1, 2\}$ ,  $j \in \{a, b\}$ . Finally,  $\alpha_F, \alpha_R \in (0, 1)$  are the forward and reverse gains of the bipolar transistors.

### B. Steady-state LCS bifurcations are determined by LCP singularities

The main issues addressed in the literature about LCS are well-posedness and asymptotic behavior of the resulting trajectories (see, e.g., [13]–[16], [39]). If  $D$  is a  $P$ -matrix (i.e., all its principal minors are positive) then, for every  $\xi$  and  $s$ , there exists a unique  $z$  satisfying (7b),(7c) and given by

$$z = [-f_D^{-1}(C\xi + E_2s)]^+. \quad (10)$$

Substituting (10) in (7a), (7) can be written explicitly as

$$\dot{\xi}(t) = F(\xi(t), r, s) \quad (11)$$

with

$$F(\xi, r, s) = A\xi + B[-f_D^{-1}(C\xi + E_2s)]^+ + E_1r. \quad (12)$$

Furthermore, it can be readily shown that  $F$  is globally Lipschitz-continuous in  $\xi$ , so that (7a)–(7c) is well posed, i.e., its solutions are global and unique. A less-explored problem is understanding how the equilibria of (7) change, appear, and disappear as a function of the input parameters  $r$  and  $s$ , that is, what is the nonsmooth steady-state bifurcation structure of (7).

The following definition formalizes the notion of nonsmooth (steady-state) bifurcation. It uses a notion of regularity that is closely related to that proposed in [40] and it is inspired by the notion of smooth steady-state bifurcation used in [41].

**Definition 7:** Given a Lipschitz-continuous map depending on  $m$  parameters,  $g : \mathbb{R}^n \times \mathbb{R}^m \rightarrow \mathbb{R}^n$ , a point  $(y_0, p_0)$  is a *regular solution* of  $g$  if  $g(y_0, p_0) = 0$  and there exists a neighborhood  $W = U \times V$  of  $(y_0, p_0)$  such that the map  $p \mapsto \{y \in U \mid g(y, p) = 0\}$  is single-valued and Lipschitz-continuous over  $V^1$ . Solutions of  $g(y, p) = 0$  that are not regular are called *bifurcations* of  $g$ .

Let  $\partial_y g(y, p)$  denote the Clarke generalized Jacobian of  $g$  with respect to  $y$  at  $(y, p)$ , that is,

$$\partial_y g(y, p) = \text{co} \left\{ \lim_{i \rightarrow \infty} D_y g(y_i, p) \mid y_i \rightarrow y, y_i \notin \Omega_g \right\},$$

where  $\Omega_g$  is the set of measure zero where the Jacobian  $D_y g$  of the Lipschitz-continuous map  $g$  does not exist. We say that  $\partial_y g(y, p)$  is of *maximal rank*, or *nonsingular*, if every matrix in  $\partial_y g(y, p)$  is nonsingular. Conversely, we say that  $\partial_y g(y, p)$  is singular if it contains a singular matrix. The following

<sup>1</sup>To simplify the exposition, a multi-valued map whose image is a singleton will be treated as a single-valued map.

proposition is a direct consequence of the nonsmooth Implicit Function Theorem [42, p. 256].

*Proposition 1:* If  $(y_0, p_0)$  is a bifurcation of  $g$  then  $\partial_y g(y_0, p_0)$  is singular.

The following theorem shows that equilibria of (7) can be put in one-to-one correspondence with the solution of an associated LCP.

*Theorem 2:* Consider (7) with  $A, B, C$  nonsingular and  $D$  a  $P$ -matrix. Define

$$M = D - CA^{-1}B \quad (13)$$

$$\bar{q}(r, s) = E_2 s - CA^{-1}E_1 r \quad (14)$$

$$X(\xi, s) = f_D^{-1}(C\xi + E_2 s) \quad (15)$$

and denote by

$$X^{-1}(x, s) = C^{-1}(f_D(x) - E_2 s) \quad (16)$$

the inverse of  $X(\cdot, s)$ . Then,  $F(\xi, r, s) = 0$  implies that  $f_M(X(\xi, s)) = \bar{q}(r, s)$ . Conversely,  $f_M(x) = \bar{q}(r, s)$  implies that  $F(X^{-1}(x, s), r, s) = 0$ .

Note that, since  $D$  is a  $P$ -matrix,  $X$  and  $X^{-1}$  are well-defined, see e.g., [12, Theorem 3.3.7].

*Proof:* It follows from Lemma 1 that  $f_D(x) = [x]^+ - D[-x]^+$  and  $f_M(x) = [x]^+ - (D - CA^{-1}B)[-x]^+$ , leading to

$$f_M(x) = f_D(x) + CA^{-1}B[-x]^+ . \quad (17)$$

Suppose that  $F(\xi, r, s) = 0$  and let  $x = X(\xi, s)$ . By (15), we have

$$f_D(x) = C\xi + E_2 s$$

which, when substituted in (17), yields

$$f_M(x) = C\xi + E_2 s + CA^{-1}B[-x]^+ . \quad (18)$$

Since  $A$  is nonsingular, we can solve for  $\xi$  in (12) to obtain

$$\xi = -A^{-1}(B[-x]^+ + E_1 r) . \quad (19)$$

Substitution of (19) into (18) leads us to  $f_M(x) = \bar{q}(r, s)$ .

Conversely, suppose that  $f_M(x) = \bar{q}(r, s)$  and set  $\xi = X^{-1}(x, s)$ . It follows from (17) and (16) that

$$\xi + A^{-1}(B[-x]^+ + E_1 r) \in \text{Ker } C , \quad (20)$$

where  $\text{Ker } C$  denotes the null space of  $C$ . Since  $C$  is nonsingular by hypothesis, then (19) holds and therefore  $F(\xi, r, s) = 0$ . ■

*Remark 1:* In the more general case where  $B \in \mathbb{R}^{n \times m}$ ,  $C \in \mathbb{R}^{m \times n}$ , and  $A \in \mathbb{R}^{n \times n}$  is nonsingular, all equilibria of (7) satisfy  $f_M(x) = \bar{q}(r, s)$  for  $x = X(\xi, s)$ . However, not all solutions of  $f_M(x) = \bar{q}(r, s)$  can be mapped to equilibrium points of (7).

*Corollary 1:* Under the same assumptions and definitions used in Theorem 2, the point  $(\xi_0, r_0, s_0)$  is a bifurcation of  $F$  if, and only if,  $(x_0, q_0) = (X(\xi_0, s_0), \bar{q}(r_0, s_0))$  is a bifurcation of  $(x, q) \mapsto f_M(x) - q$ .

*Proof:* By Theorem 2,

$$\{x \mid f_M(x) = \bar{q}(r, s)\} = \{X(\xi, s) \mid F(\xi, r, s) = 0\}$$

and, similarly,

$$\{\xi \mid F(\xi, r, s) = 0\} = \{X^{-1}(x, s) \mid f_M(x) = \bar{q}(r, s)\} .$$

Then, the map  $(r, s) \mapsto \{x \mid f_M(x) = \bar{q}(r, s)\}$  can be expressed as the composition of the map  $(r, s) \mapsto \{\xi \mid F(\xi, r, s) = 0\}$  and the Lipschitz map  $X(\cdot, s)$ , and, vice versa, the map  $(r, s) \mapsto \{x \mid f_M(x) = \bar{q}(r, s)\}$  can be expressed as the composition of the map  $(r, s) \mapsto \{x \mid f_M(x) = \bar{q}(r, s)\}$  and the Lipschitz map  $X^{-1}(\cdot, s)$ . Recalling that the composition of Lipschitz-continuous maps is Lipschitz-continuous, the map  $(r, s) \mapsto \{\xi \mid F(\xi, r, s) = 0\}$  is single-valued and Lipschitz-continuous in a neighborhood of  $(\xi_0, r_0, s_0)$  if, and only if, the map  $(r, s) \mapsto \{x \mid f_M(x) = \bar{q}(r, s)\}$  is single-valued and Lipschitz-continuous in a neighborhood  $(X(\xi_0, s_0), r_0, s_0)$ . ■

It follows that the steady-state bifurcations of an LCS are fully characterized by the bifurcations of an associated LCP. Furthermore, by Proposition 1, we can make two key observations. First, LCS bifurcations are non-hyperbolic equilibria of (7), in the sense that Jacobian  $\partial_\xi F(\xi, r, s)$  at a bifurcation point contains matrices with some zero eigenvalues. As such, system (7) can lose stability at bifurcations. Second, bifurcations of an LCP can be found constructively by looking for its *singularities*, i.e., points  $(x_0, q_0)$  such that  $f_M(x_0) - q_0 = 0$  and  $\partial_x f_M(x_0)$  is singular. Observing that

$$\partial f_M(x) = \text{co}\{C_{-M}(\alpha) \mid x \in \text{pos } C_I(\alpha)\} ,$$

it follows that  $\partial f_M(x)$  is a singleton whenever  $x$  belongs to the interior of an orthant and a set of matrices whenever  $x$  belongs to the common boundary of two or more orthants. Hence, for a point  $(x_0, q_0)$  to be a nonsmooth singularity of the LCP( $M, q$ ) it is necessary that, for some  $\alpha \subseteq [1 \dots n]$ , either  $x_0 \in \text{bdr pos } C_I(\alpha)$  or  $x_0 \in \text{int pos } C_I(\alpha)$  with  $C_{-M}(\alpha)$  singular. In the former case  $\partial f_M$  is a set for which the maximal rank condition may not hold, whereas in the latter case  $\partial f_M$  is a singular matrix and therefore it is not of maximal rank. Note that, in both cases,  $q_0 \in \text{bdr } C_M(\alpha)$ . Therefore, nonsmooth bifurcations in LCPs are essentially determined by the configuration of the complementarity cones and how  $q$  moves across them. The notion of equivalence for LCPs introduced in the next section helps in the task of analyzing and classifying complementarity-cone configurations, as illustrated through both applied and theoretical extended examples.

## V. EQUIVALENCE OF LCPs

Our notion of equivalence between an LCP( $M, q$ ) and an LCP( $N, r$ ) involves both topological and algebraic properties. The algebraic properties deal with the relations among the complementary cones of  $M$  and  $N$ . The relevant algebraic structure is that of a Boolean algebra, a subject that we now briefly recall (see [43], [44] for more details).

*Definition 8:* Let  $X$  be a set. A *field of sets* is a pair  $(X, \mathcal{F})$ , where  $\mathcal{F} \subseteq \mathcal{P}(X)$  is any non-empty family of sets that is closed under the set operations of complement and finite union.

It follows easily from the De Morgan rules that a field of sets  $(X, \mathcal{F})$  is also closed under finite intersections of sets. Note also that  $\emptyset$  and  $X$  are always members of  $\mathcal{F}$ . In the cases when the set  $X$  is clear from the context, we will denote the field of sets simply by the collection  $\mathcal{F}$ . Fields of sets are concrete examples of Boolean algebras, see, e.g., [44]. Therefore, the usual algebraic concepts apply to them.

*Definition 9:* Consider the fields  $(X, \mathcal{F})$  and  $(\hat{X}, \hat{\mathcal{F}})$ . A mapping  $h : \mathcal{F} \rightarrow \hat{\mathcal{F}}$  is said to be *Boolean* if, for all  $P_1, P_2 \in \mathcal{F}$ ,

$$h(P_1 \cap P_2) = h(P_1) \cap h(P_2)$$

and

$$h(X \setminus P_1) = \hat{X} \setminus h(P_1).$$

A Boolean map that is also a bijection is said to be a *Boolean isomorphism*. A Boolean isomorphism that maps a field of sets to itself is said to be a *Boolean automorphism*.

*Definition 10:* A map  $\varphi_* : \mathcal{F} \rightarrow \hat{\mathcal{F}}$  is said to be *induced* by a map  $\varphi : \hat{X} \rightarrow X$  if, for every set  $P \in \mathcal{F}$ ,

$$\varphi_*(P) = \varphi^{-1}(P).$$

Let  $\mathcal{G} \subseteq \mathcal{P}(X)$ . The field of sets *generated* by  $\mathcal{G}$ , denoted  $\text{span} \mathcal{G}$ , is the intersection of all the fields of sets containing  $\mathcal{G}$ . That is, it is the smallest field of sets containing  $\mathcal{G}$ . In what follows, we consider the collection of complementary cones  $\mathcal{G}_M = \{\text{pos } C_M(\alpha)\}_\alpha$  and we denote the field of sets generated by  $\mathcal{G}_M$  as  $\mathcal{F}_M$ .

We are now ready to introduce our main definition.

*Definition 11:* Two matrices  $M, N \in \mathbb{R}^{n \times n}$  are *LCP-equivalent*, denoted  $M \sim N$ , if the fields of sets  $\mathcal{F}_M$  and  $\mathcal{F}_N$  are isomorphic and the Boolean isomorphism  $\varphi_* : \mathcal{F}_M \rightarrow \mathcal{F}_N$  is induced by a homeomorphism  $\varphi : \mathbb{R}^n \rightarrow \mathbb{R}^n$ .

In other words, two matrices are LCP-equivalent if the Boolean structures of their associated complementary cones are isomorphic. That is, if there is a bijection  $\varphi_* : \mathcal{F}_M \rightarrow \mathcal{F}_N$  preserving intersections, unions, and complements of complementary cones. Since  $\varphi_*$  is required to be induced by a homeomorphism, it suffices to verify that  $\varphi$  induces a bijection from  $\mathcal{G}_M$  to  $\mathcal{G}_N$  [29, Cor. 12].

As an illustration, let us consider the matrices

$$M = \begin{bmatrix} 1 & 1 \\ 1 & 1 \end{bmatrix} \quad \text{and} \quad N = \begin{bmatrix} 1 & -1 \\ 1 & 0 \end{bmatrix}. \quad (21)$$

The associated complementary cones are depicted in Fig. 3. Note that, although  $M$  is singular and  $N$  is not, they are in fact LCP-equivalent. To see this, consider the homeomorphism  $\varphi : \mathbb{R}^2 \rightarrow \mathbb{R}^2$ ,

$$\varphi(q') = \begin{bmatrix} -1 & 0 \\ -1 & 1 \end{bmatrix} q'.$$

Simple but lengthy computations show that

$$\varphi_* : \text{pos } C_M(\alpha) \mapsto \text{pos } C_N(\beta(\alpha))$$

with  $\beta : \mathcal{P}([1 \dots n]) \rightarrow \mathcal{P}([1 \dots n])$  given by

$$\emptyset \mapsto \{1\}, \quad \{1\} \mapsto \emptyset, \quad \{2\} \mapsto \{1, 2\}, \quad \{1, 2\} \mapsto \{2\}.$$

That is,  $\varphi$  induces a bijection  $\mathcal{G}_M \rightarrow \mathcal{G}_N$  and hence an isomorphism  $\mathcal{F}_M \rightarrow \mathcal{F}_N$ .

*Theorem 3:* Consider two matrices  $M, N \in \mathbb{R}^{n \times n}$  and suppose there exists homeomorphisms  $\varphi, \psi : \mathbb{R}^n \rightarrow \mathbb{R}^n$  such that

$$f_M = \varphi \circ f_N \circ \psi, \quad (22)$$

where  $\psi$  induces a Boolean automorphism on  $\mathcal{F}_I$ . Then,  $M \sim N$ .

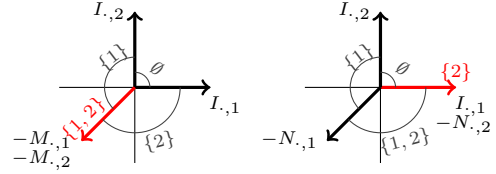

Fig. 3. Complementary cones associated with the matrices  $M$  (left) and  $N$  (right) from (21). Red rays denote degenerate complementary cones.

*Proof:* Since  $\psi_*$  is an automorphism on  $\mathcal{F}_I$ , for any  $\alpha \subseteq [1 \dots n]$ , there exists a unique  $\beta \subseteq [1 \dots n]$  such that  $\text{pos } C_I(\alpha) = \psi^{-1}(\text{pos } C_I(\beta))$ . It then follows from (3) and (22) that  $\varphi^{-1}(C_{-M}(\alpha)x) = C_{-N}(\beta)\psi(x)$  for  $x \in \text{pos } C_I(\alpha)$ . By (4) we finally have

$$\varphi^{-1}(\text{pos } C_M(\alpha)) = \text{pos } C_N(\beta),$$

which shows that  $\varphi$  induces a bijection from  $\mathcal{G}_M$  to  $\mathcal{G}_N$ . ■

There is a slightly weaker converse result.

*Theorem 4:* Consider two non-degenerate matrices  $M, N \in \mathbb{R}^{n \times n}$  and suppose that  $M \sim N$  with homeomorphism  $\varphi$ . Then, there exists another homeomorphism  $\psi : \mathbb{R}^n \rightarrow \mathbb{R}^n$  that induces an automorphism  $\psi_* : \mathcal{F}_I \rightarrow \mathcal{F}_I$  and such that (22) holds.

*Proof:* The bijectivity of  $\varphi_* : \mathcal{F}_M \rightarrow \mathcal{F}_N$  implies that, for each  $\alpha \subseteq [1 \dots n]$ , there exists a unique  $\beta \subseteq [1 \dots n]$  such that

$$\varphi_*(\text{pos } C_M(\alpha)) = \text{pos } C_N(\beta). \quad (23)$$

We will explicitly construct a piecewise linear map  $\psi : \mathbb{R}^n \rightarrow \mathbb{R}^n$  and verify (22). By (4) and (23), for each  $x \in \text{pos } C_I(\alpha)$  there exists an  $x' \in \text{pos } C_I(\beta)$  such that

$$\varphi^{-1}(C_{-M}(\alpha)x) = C_{-N}(\beta)x'. \quad (24)$$

Moreover,  $x'$  is unique by the invertibility of  $C_{-N}$  (which follows by the non-degeneracy of  $N$ ). We define  $\psi : x \mapsto x'$  with  $x'$  so constructed, so that

$$\varphi^{-1}(C_{-M}(\alpha)x) = C_{-N}(\beta)\psi(x)$$

for  $x \in \text{pos } C_I(\alpha)$ . This is simply an explicit rewriting of (22). Since  $\varphi^{-1}$  is bijective, we can reverse the argument in order to find  $\psi^{-1}$ . The continuity of  $\psi$  and  $\psi^{-1}$  are simple consequences of the continuity of  $\varphi$ ,  $\varphi^{-1}$ ,  $f_M$  and  $f_N$ .

Finally, note that  $\psi$  induces a permutation on  $\mathcal{G}_I$ , and hence an automorphism on  $\mathcal{F}_I$ . ■

Condition (22) is the commutative diagram

$$\begin{array}{ccc} \mathbb{R}^n & \xrightarrow{\psi} & \mathbb{R}^n \\ f_M \downarrow & & \downarrow f_N \\ \mathbb{R}^n & \xleftarrow{\varphi} & \mathbb{R}^n \end{array}.$$

It is standard in the literature of singularity theory [30] and ensures that we can continuously map solutions of the problem  $f_M(x) = q$  into solutions of the problem  $f_N(x') = \varphi^{-1}(q)$ . The requirement on  $\psi$  being a Boolean automorphism implies that  $\psi$  maps orthants into orthants, intersections of orthants into intersections of orthants, and so forth; and this ensures

that the complementarity condition is not destroyed by the homeomorphisms.

Linear homeomorphisms preserving the complementarity conditions include permutations of coordinates and dilations of the coordinate axes [37].

*Corollary 2:* Let  $P \in \mathbb{R}^{n \times n}$  be a permutation matrix. Then, for any matrix  $M \in \mathbb{R}^{n \times n}$ ,  $M \sim N = P^\top M P$ .

*Proof:* Let  $\varphi(q') = P q'$  and  $\psi(x) = P^\top x$ , and note that  $\psi$  induces a Boolean automorphism on  $\mathcal{F}_I$ . Also, note that  $P[x]^+ = [P x]^+$ . The proof then follows from (6),

$$\begin{aligned} f_M(x) &= [x]^+ - M[-x]^+ = \\ &P([P^\top x]^+ - N[-P^\top x]^+) = \varphi \circ f_N \circ \psi(x). \end{aligned}$$

*Corollary 3:* Let  $D \in \mathbb{R}^{n \times n}$  be a diagonal matrix with strictly positive entries. Then, for any matrix  $M \in \mathbb{R}^{n \times n}$ ,  $M \sim D^{-1} M D$  and  $M \sim M D$ .

*Proof:* For the first equivalence, let  $\varphi(q') = D q'$  and  $\psi(x) = D^{-1} x$ , and note that  $\psi$  is a Boolean automorphism on  $\mathcal{F}_I$ . We also have  $D[x]^+ = [D x]^+$ . As in the previous corollary,  $f_M(x) = \varphi \circ f_N \circ \psi(x)$ . For the second equivalence, let  $\varphi$  be the identity map,  $\varphi(q) = q$ , and  $\psi(x) = C_{-D}(\alpha)x$  for  $x \in \text{pos } C_I(\alpha)$ . Both  $\varphi$  and  $\psi$  are continuous and invertible. Hence,  $f_{MD}(x) = C_{-MD}(\alpha)x = C_{-M}(\alpha)C_{-D}(\alpha)x = \varphi \circ f_M \circ \psi(x)$ , for some  $\alpha \in [1 \dots n]$  and the conclusion follows. ■

*Definition 12:* Let  $M \in \mathbb{R}^{n \times n}$  and  $\beta \subseteq [1 \dots n]$  be such that  $M_{\beta, \beta}$  is nonsingular. The *principal pivotal transform* (PPT) of  $M$  relative to  $\beta$  is the matrix  $N \in \mathbb{R}^{n \times n}$  defined by

$$\begin{aligned} N_{\beta, \beta} &= (M_{\beta, \beta})^{-1} \\ N_{\beta, \beta^c} &= -(M_{\beta, \beta})^{-1} M_{\beta, \beta^c} \\ N_{\beta^c, \beta} &= M_{\beta^c, \beta} (M_{\beta, \beta})^{-1} \\ N_{\beta^c, \beta^c} &= M_{\beta^c, \beta^c} - M_{\beta^c, \beta} (M_{\beta, \beta})^{-1} M_{\beta, \beta^c} \end{aligned}$$

By convention, the PPT of  $M$  relative to  $\emptyset$  is  $M$ .

*Corollary 4:* Let  $N$  be the PPT of  $M$  with respect to  $\beta$ . Then,  $M \sim N$ .

*Proof:* If  $\beta = \emptyset$  the result holds trivially, so we suppose that  $\beta \neq \emptyset$ . Let  $P \in \mathbb{R}^{n \times n}$  be the permutation matrix such that  $P^\top \xi = [\xi_\beta^\top, \xi_{\beta^c}^\top]^\top$  and define  $\psi(x) = C_I(\beta)x$ . It follows from (6) that

$$\begin{aligned} &P^\top (f_M \circ \psi)(x) \\ &= [P^\top C_I(\beta)x]^+ - P^\top M P [-P^\top C_I(\beta)x]^+ \\ &= \begin{bmatrix} -x_\beta \\ x_{\beta^c} \end{bmatrix}^+ - \begin{bmatrix} M_{\beta, \beta} & M_{\beta, \beta^c} \\ M_{\beta^c, \beta} & M_{\beta^c, \beta^c} \end{bmatrix} \begin{bmatrix} x_\beta \\ -x_{\beta^c} \end{bmatrix}^+ \\ &= \begin{bmatrix} -M_{\beta, \beta} & 0 \\ -M_{\beta^c, \beta} & I_{|\beta^c|} \end{bmatrix} \begin{bmatrix} x_\beta \\ x_{\beta^c} \end{bmatrix}^+ - \begin{bmatrix} -I_{|\beta|} & M_{\beta, \beta^c} \\ 0 & M_{\beta^c, \beta^c} \end{bmatrix} \begin{bmatrix} -x_\beta \\ -x_{\beta^c} \end{bmatrix}^+ \\ &= \begin{bmatrix} -M_{\beta, \beta} & 0 \\ -M_{\beta^c, \beta} & I_{|\beta^c|} \end{bmatrix} ([P^\top x]^+ - P^\top N P [-P^\top x]^+) \\ &= \begin{bmatrix} -M_{\beta, \beta} & 0 \\ -M_{\beta^c, \beta} & I_{|\beta^c|} \end{bmatrix} P^\top f_N(x) \end{aligned}$$

Hence,  $f_N = \varphi \circ f_M \circ \psi$  with

$$\varphi(q') = P \begin{bmatrix} -M_{\beta, \beta}^{-1} & 0 \\ -M_{\beta^c, \beta} M_{\beta, \beta}^{-1} & I_{|\beta^c|} \end{bmatrix} P^\top q'. \quad (25)$$

Therefore,  $N \sim M$ . ■

## VI. STABILITY OF LCPS

We are now concerned with how stable the structure of the complementary cones of an LCP( $M, q$ ) is with respect to changes in  $M$ .

### A. Definition and characterization of stability

Henceforth, we consider the usual topology on the vector space  $\mathbb{R}^{n \times n}$ .

*Definition 13:* A matrix  $M \in \mathbb{R}^{n \times n}$  is *LCP-stable* if there exists a neighborhood  $U$  of  $M$  such that  $M \sim N$  for all  $N \in U$ .

In order to characterize LCP stability, we take a deeper look into the geometric properties of the facets of the complementary cones. Recalling that  $\mathcal{K}(M)$  denotes the union of all facets of the complementary cones of  $M \in \mathbb{R}^{n \times n}$ . Then,  $\mathcal{K}(M) = \bigcup_\alpha \text{bdr } C_M(\alpha)$  [12, p. 511] and it breaks down  $\mathbb{R}^n$  into a finite number of connected regions.

*Definition 14:* Let  $M \in \mathbb{R}^{n \times n}$ . The *partition induced* by  $M$ , denoted as  $\mathcal{Q}_M$ , is the finite family of connected components of  $\mathbb{R}^n \setminus \mathcal{K}(M)$ .

A set  $Q_M^i \in \mathcal{Q}_M$  is called a *cell* of  $\mathcal{Q}_M$ . The number of cells,  $r$ , in the partition induced by  $M$  depends on the number of solid complementary cones and how they intersect. The following properties are easy to verify,

- i)  $Q_M^i \cap Q_M^j = \emptyset$  for  $i \neq j$ ,  $i, j \in [1 \dots r]$ ,
- ii)  $\mathbb{R}^n = \text{cl } \bigcup_i Q_M^i$ ,
- iii)  $\mathcal{K}(M) = \bigcup_i \text{bdr } Q_M^i$ .

The cells of the partition are (non-necessarily convex) open cones delimited by the facets of the solid complementary cones of  $M$ . For  $P$ -matrices, the cells of the partition precisely agree with the interior of the complementary cones of  $M$ , see e.g., [45].

*Lemma 2:* Let  $M \in \mathbb{R}^{n \times n}$  be an  $R_0$  matrix and let  $r$  be the number of sets in  $\mathcal{Q}_M$ . For every  $\alpha \subseteq [1 \dots n]$  there exists  $J \subseteq [1 \dots r]$  such that either

$$\text{pos } C_M(\alpha) = \text{cl } \bigcup_{j \in J} Q_M^j$$

(when  $\text{pos } C_M(\alpha)$  has non-empty interior) or

$$\text{pos } C_M(\alpha) \subset \bigcup_{j \in J} \text{bdr } Q_M^j$$

(when the interior of  $\text{pos } C_M(\alpha)$  is empty).

*Proof:* Assume first that  $\text{pos } C_M(\alpha)$  is a solid cone. Then, there exists  $j_1 \in [1 \dots r]$  such that  $Q_M^{j_1} \subset \text{pos } C_M(\alpha)$ . Let  $\mu(E)$  be the Lebesgue measure of  $E \subset \mathbb{R}^n$ . If

$$\mu(\text{pos } C_M(\alpha) \setminus Q_M^{j_1}) = 0,$$

then  $\text{pos } C_M(\alpha) = \text{cl } Q_M^{j_1}$ , as desired. If

$$\mu(\text{pos } C_M(\alpha) \setminus Q_M^{j_1}) > 0,$$



then there exists  $j_2 \in [1 \dots r]$ ,  $j_2 \neq j_1$ , such that  $Q_M^{j_2} \subset (\text{pos } C_M(\alpha) \setminus Q_M^{j_1})$ . As before, if

$$\mu\left(\text{pos } C_M(\alpha) \setminus \left(Q_M^{j_1} \cup Q_M^{j_2}\right)\right) = 0,$$

then  $\text{pos } C_M(\alpha) = \text{cl}\left(Q_M^{j_1} \cup Q_M^{j_2}\right)$ , as desired. Since  $\text{pos } C_M(\alpha)$  is strictly pointed and  $\mathcal{Q}_M$  is finite and the union is dense in  $\mathbb{R}^n$  (property ii) above), the procedure just introduced stops after a finite number of iterations with  $J \subset [1 \dots r]$  and the result follows. Suppose now that  $\text{pos } C_M(\alpha)$  is degenerate. Then,  $\text{pos } C_M(\alpha) \subset \bigcup_{j \in J} \text{bdr } Q_M^j \subset \mathcal{K}(M)$  for some  $J \subset [1 \dots r]$ . ■

*Corollary 5:*  $M \sim N$  if, and only if, there exists a bijection  $\hat{\varphi}_* : \mathcal{Q}_M \rightarrow \mathcal{Q}_N$  induced by a homeomorphism  $\hat{\varphi} : \mathbb{R}^n \rightarrow \mathbb{R}^n$ .

*Proof:* Suppose that  $M \sim N$ . Then, there is a homeomorphism  $\varphi : \mathbb{R}^n \rightarrow \mathbb{R}^n$  such that

$$\varphi^{-1}(\text{bdr } \text{pos } C_M(\alpha)) = \text{bdr } \text{pos } C_N(\beta(\alpha))$$

and

$$\varphi^{-1}(\text{int } C_M(\alpha)) = \text{int } C_N(\beta(\alpha)),$$

for all  $\alpha \subset [1 \dots n]$  and some

$$\beta : \mathcal{P}([1 \dots n]) \rightarrow \mathcal{P}([1 \dots n]).$$

Thus,  $\varphi^{-1}$  maps connected regions of  $\mathbb{R}^n \setminus \mathcal{K}(M)$  into connected regions of  $\mathbb{R}^n \setminus \mathcal{K}(N)$ , thereby inducing a bijection between  $\mathcal{Q}_M$  and  $\mathcal{Q}_N$ .

On the other hand, if  $\hat{\varphi}$  induces a bijection  $\hat{\varphi}_*$ , it follows from Lemma 2 and the continuity of  $\hat{\varphi}$ , that  $\hat{\varphi}$  also induces an isomorphism between  $\mathcal{F}_M$  and  $\mathcal{F}_N$ . ■

Corollary 5 implies that, if  $M \sim N$ , then  $\mathcal{Q}_M$  and  $\mathcal{Q}_N$  must have the same number of cells.

Consider a matrix  $M \in \mathbb{R}^{n \times n}$  and a vector  $-M_{\cdot,k}$  with  $k \in [1 \dots n]$ , and let  $\mathcal{T}_k(M)$  be the collection of facets for which  $-M_{\cdot,k}$  is not a generator,

$$\mathcal{T}_k(M) := \left\{ S \subset \mathbb{R}^n \mid S = \text{pos } C_M(\alpha)_{\cdot,ic}, \right. \\ \left. \alpha \subseteq [1 \dots n], k \notin \alpha, i \in [1 \dots n] \right\}.$$

*Definition 15:* Given  $M \in \mathbb{R}^{n \times n}$ , we say that  $M$  is *weakly degenerate* if it has a degenerate complementary cone or if

$$-M_{\cdot,k} \in \bigcup_{S \in \mathcal{T}_k(M)} S$$

for some  $k \in [1 \dots n]$ .

As an illustration, consider the matrix

$$M = \begin{bmatrix} \frac{1}{2} & \frac{5}{3} & 0 \\ 1 & 1 & 0 \\ -\frac{3}{10} & -1 & 1 \end{bmatrix}. \quad (26)$$

It is lengthy but straightforward to verify that there are no degenerate complementary cones, so  $M$  is non-degenerate. However, note that

$$\mathcal{T}_2(M) = \left\{ \text{pos}[I_{\cdot,2}, I_{\cdot,3}], \text{pos}[I_{\cdot,2}, -M_{\cdot,3}], \text{pos}[I_{\cdot,1}, I_{\cdot,3}], \right. \\ \left. \text{pos}[-M_{\cdot,1}, I_{\cdot,3}], \text{pos}[I_{\cdot,1}, -M_{\cdot,3}], \right. \\ \left. \text{pos}[-M_{\cdot,1}, -M_{\cdot,3}], \text{pos}[I_{\cdot,1}, I_{\cdot,2}], \text{pos}[-M_{\cdot,1}, I_{\cdot,2}] \right\}$$

and that  $-M_{\cdot,2} \in \text{pos}[-M_{\cdot,1}, I_{\cdot,2}]$ , so  $M$  is a weakly degenerate matrix. Fig. 4 depicts the partitions that  $M$  and a perturbation  $\tilde{M}$  induce on the unit ball.

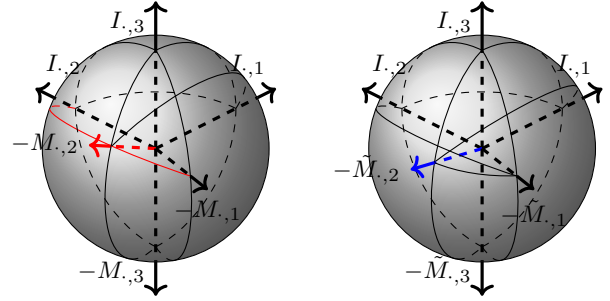

**Fig. 4.** Projection onto the unit ball of complementary cones of the matrix  $M$  defined in (26)(left) and a perturbation  $\tilde{M}$  (right). The generator  $-M_{\cdot,2} \in \text{pos}[-M_{\cdot,1}, I_{\cdot,2}]$  (in red). Thus,  $M$  is weakly degenerate whereas  $\tilde{M}$  is not.

*Lemma 3:* The set of weakly degenerate matrices is nowhere dense in  $\mathbb{R}^{n \times n}$ .

*Proof:* By definition, a weakly degenerate matrix  $M$  belongs to the union of the set of singular matrices and the set

$$H := \left\{ M \in \mathbb{R}^{n \times n} \mid \text{there exist } k \in [1 \dots n] \text{ and } S \in \mathcal{T}_k(M) \text{ such that } -M_{\cdot,k} \in S \right\}. \quad (27)$$

It is well known that the set of singular matrices is nowhere dense in  $\mathbb{R}^{n \times n}$ . Indeed, the same is true for the set  $H$ . Consider  $\hat{S} \in \mathbb{R}^{n \times (n-1)}$  such that  $\text{pos } \hat{S} \in \mathcal{T}_k(M)$ . It follows that  $\det([\hat{S}, -M_{\cdot,k}]) = 0$  and  $H$  is nowhere dense. To conclude, recall that the finite union of nowhere dense sets is again nowhere dense. ■

*Theorem 5:* A matrix  $M \in \mathbb{R}^{n \times n}$  is LCP-stable if, and only if,  $M$  is not weakly degenerate.

*Proof:* Let us assume first that some complementary cones of  $M$  are degenerate. Since the set of matrices with non-zero principal minors is dense in the set of square matrices, there exists a matrix  $N$ , arbitrarily close to  $M$ , without degenerate complementary cones. A bijection  $\varphi_* : \mathcal{G}_M \rightarrow \mathcal{G}_N$  necessarily maps a complementary cone with empty interior onto a complementary cone with non-empty interior. Clearly,  $\varphi : \mathbb{R}^n \rightarrow \mathbb{R}^n$  cannot be invertible and hence cannot be a homeomorphism. Therefore,  $M$  is not LCP-stable.

Assume now that  $M \in H$ . Then, there is  $J \subset [1 \dots n]$  such that, for each  $k \in J$ , there exists a matrix  $\hat{S} \in \mathbb{R}^{n \times (n-1)}$  satisfying

$$\text{pos}[\hat{S}, -M_{\cdot,k}] = \text{pos } \hat{S} = S \in \mathcal{T}_k(M).$$

From Lemma 3, there exists  $N \in \mathbb{R}^{n \times n}$  arbitrarily close to  $M$  such that  $N$  is not weakly degenerate. In other words,  $\det[\hat{S}, -N_{\cdot,k}] \neq 0$ , so that  $\text{pos}[\hat{S}, -N_{\cdot,k}]$  has non-empty interior. Once again, there is no homeomorphism mapping  $\text{pos}[\hat{S}, -M_{\cdot,k}]$  into  $\text{pos}[\hat{S}, -N_{\cdot,k}]$ . It follows that  $M$  is not LCP-stable.

For sufficiency, let us assume that  $M$  is not weakly degenerate. There exists a neighborhood  $U$  of  $M$  such that, for every  $N \in U$ , the partitions  $\mathcal{Q}_M$  and  $\mathcal{Q}_N$  have the same number of

cells. Indeed, each cell in  $\mathcal{Q}_M$  is a solid cone by construction and, because there are no degenerate cones nor  $k \in [1 \dots n]$  such that  $-M_{\cdot,k} \in S$  for some  $S \in \mathcal{T}_k(M)$ , the cells remain solid for sufficiently small perturbations. Thus, neither new cells appear nor existing cells disappear in  $U$ .

Now, there exist refinements  $\hat{\mathcal{Q}}_M$  and  $\hat{\mathcal{Q}}_N$  of the partitions induced by  $M$  and  $N \in U$ , respectively, such that each cell is a convex cone with exactly  $n$  generators and the number of cells is the same for both partitions. There is thus a one-to-one map  $\eta : \hat{\mathcal{Q}}_M \rightarrow \hat{\mathcal{Q}}_N$  such that neighbors are preserved, that is, any two cells in  $\hat{\mathcal{Q}}_M$  sharing a  $p$ -dimensional face are mapped under  $\eta$  into cells in  $\hat{\mathcal{Q}}_N$  sharing also a  $p$ -dimensional face. Let  $\hat{Q}_k(M)$  and  $\hat{Q}_k(N) = \eta(\hat{Q}_k(M))$  be, respectively, matrices that generate the cells of the new partitions  $\hat{\mathcal{Q}}_M$  and  $\hat{\mathcal{Q}}_N$ , where  $k \in [1 \dots \hat{r}]$  and  $\hat{r} = |\hat{\mathcal{Q}}_M| = |\hat{\mathcal{Q}}_N|$ . Define  $\hat{\varphi} : \mathbb{R}^n \rightarrow \mathbb{R}^n$  as the piecewise linear function

$$\hat{\varphi}(q') = \hat{Q}_k(M)\hat{Q}_k(N)^{-1}q' \text{ for } q' \in \text{pos } \hat{Q}_k(N). \quad (28)$$

Notice that  $\hat{\varphi}$  is continuous by construction, since neighbor cells share  $n - 1$  generators. That is,

$$\lim_{\substack{q'_i \rightarrow q \\ q'_i \in \text{pos } \hat{Q}_k(N)}} \hat{\varphi}(q'_i) = \lim_{\substack{q'_i \rightarrow q \\ q'_i \in \text{pos } \hat{Q}_s(N)}} \hat{\varphi}(q'_i)$$

for any  $q' \in \text{pos } \hat{Q}_k(N) \cap \text{pos } \hat{Q}_s(N)$ . Finally, by similar arguments,  $\hat{\varphi}^{-1}$  exists and is also continuous. Furthermore,  $\hat{\varphi}_* : \mathcal{Q}_M \rightarrow \mathcal{Q}_N$  is a bijection. Therefore,  $M$  and  $N$  are LCP-equivalent and, since  $N$  is arbitrary, we conclude that  $M$  is LCP-stable. ■

## B. Explicit conditions for stability

Weak degeneracy is connected to the *positive* linear dependence property of particular subsets of generators of  $M$ , which is difficult to verify for large matrices [46]. On the other hand, efficient algorithms for verifying linear dependence are readily available. This motivates the following.

*Corollary 6:* If all minors of  $M \in \mathbb{R}^{n \times n}$  are different from zero, then  $M$  is LCP-stable.

*Proof:* Note that, if every minor of  $M$  is non-zero, then  $M$  cannot be weakly degenerate. Indeed, using Laplace's expansion we can see that, for any non-empty sets  $\alpha, \beta \subseteq [1 \dots n]$  such that  $|\alpha| = |\beta|$ ,

$$|\det M_{\alpha,\beta}| = |\det [I_{\cdot,\alpha^c}, M_{\cdot,\beta}]|. \quad (29)$$

Thus, our assumption on the minors of  $M$  implies that any subset of  $n$  vectors of

$$\{I_{\cdot,1}, \dots, I_{\cdot,n}, -M_{\cdot,1}, \dots, -M_{\cdot,n}\}$$

is linearly independent. Consequently,  $M$  does not have degenerate cones and  $-M_{\cdot,k}$  is not in the linear span of  $S$  for all  $S \in \mathcal{T}_k(M)$ . That is,  $M$  is not weakly degenerate. ■

## VII. APPLICATION TO NEGATIVE-RESISTANCE CIRCUITS

We will apply the results of the previous sections to the analysis of the circuit described in Section IV-A. The application is motivated by [33], where the authors present

a heuristic procedure for constructing negative differential-resistance devices using only BJTs and resistors. The design strategy outlined in [33] ensures the satisfaction of an analytic condition that is necessary for having multiple solutions. Still, the question of whether a particular circuit actually exhibits negative resistance is settled by simulations. In this section, we employ the LCP formalism to derive necessary and sufficient conditions for having a negative resistance. Our objective is to find values of parameters that guarantee bistability of the network, resulting in the hysteretic behavior intrinsic of differential negative-resistance devices.

### A. Circuit equilibria

Recall that the equilibria of (7) are characterized by the solutions to the LCP( $M, q$ ), where  $M$  and  $q$  are given in (13) and (14). The matrix inverse in (13) complicates the computation of equilibria and the ensuing bifurcation analysis. Fortunately, the results of the previous sections ease the computational burden and open the way for an analytical treatment.

Let  $A, B, C \in \mathbb{R}^{4 \times 4}$  be nonsingular and defined by (8) and (9), and let  $N := -CA^{-1}B$ . By applying a pivotal transformation to  $N$  with  $\beta = \{1, 2, 3, 4\}$  we obtain

$$\hat{M} := -B^{-1}AC^{-1}.$$

By Corollary 4,  $N \sim \hat{M}$ . Let  $M$  and  $q$  be defined by (13), (14), (8) and (9). If  $N$  is stable,  $M = N + D \sim \hat{M}$  for  $\|D\|$  small enough. Moreover, the solutions of the LCP( $M, q$ ) can be continuously mapped into the solutions of the LCP( $\hat{M}, \hat{q}$ ) with

$$\hat{q} := B^{-1}(AC^{-1}E_2s - E_1r),$$

where the expression follows from  $\hat{q} = \varphi^{-1}(q)$  with  $\varphi$  as in (25).

The interest of  $M \sim \hat{M}$  is that we no longer require to compute  $M$ , which involves the inverse of  $A$ , defined by (8) and (9). Instead, we require to compute  $\hat{M}$ , which is easy, since  $B$  is block diagonal and  $C = -I_4$ . Indeed,  $\hat{M}$  is given explicitly in Equation (\*).

### B. Circuit bifurcations

We regard the potential difference  $r = P_1 - P_0$  as a bifurcation or control parameter. We wish to find a set of resistor values for which, by changing  $r$ , the circuit transitions from global stability to bistability. The following corollary gives sufficient conditions for attaining this objective.

*Corollary 7 ([37, Corollary 4.3]):* Let  $\hat{M} \in \mathbb{R}^{n \times n}$  be an  $R_0$ -matrix such that  $\deg_{\hat{M}}(q) = 1$  for some  $q \in \mathbb{R}^n$  and  $f_{\hat{M}}$  has only one negative index. Then, there is  $\alpha_0 \subseteq [1 \dots n]$  such that, for any  $\hat{q} \in \text{int pos } C_{\hat{M}}(\alpha_0)$ , the LCP( $\hat{M}, \hat{q}$ ) has exactly three solutions, whereas if  $\hat{q} \in \mathbb{R}^n \setminus \text{pos } C_{\hat{M}}(\alpha_0)$ , the solution is unique.

With an explicit expression for  $\hat{M}$ , it is straightforward to check the conditions of Corollary 7.

$$\hat{M} = \begin{bmatrix} \frac{G_0^a + (1-\alpha_F)(G_2^a + G_2)}{\alpha_R G_0^a - (1-\alpha_R)(G_2^a + G_2)} & \frac{\alpha_F(G_1^a + G_1) - (1-\alpha_F)(G_2^a + G_2)}{G_1^a + G_1 + (1-\alpha_R)(G_2^a + G_2)} & -G_1 & \frac{\alpha_F G_1 - (1-\alpha_F)G_2}{G_1 + (1-\alpha_R)G_2} \\ -G_2 & \frac{\alpha_F G_2 - (1-\alpha_F)G_1}{G_2 + (1-\alpha_R)G_1} & -\frac{G_1}{\alpha_R} & \frac{\alpha_F}{\alpha_R} \\ -\frac{G_2}{\alpha_R} & \frac{\alpha_F}{\alpha_R} & \frac{G_0^b + (1-\alpha_F)(G_2^b + G_1)}{\alpha_R} & \frac{\alpha_F(G_1^b + G_2) - (1-\alpha_F)(G_2^b + G_1)}{\alpha_R} \\ \frac{G_0^b - (1-\alpha_R)(G_2^b + G_1)}{\alpha_R} & \frac{\alpha_F}{\alpha_R} & \frac{G_1^b + G_2 + (1-\alpha_R)(G_2^b + G_1)}{\alpha_R} & \frac{\alpha_F}{\alpha_R} \end{bmatrix}. \quad (*)$$

$R_0^a = 100 \Omega$	$R_1^a = 2.2 \text{ k}\Omega$	$R_2^a = 100 \Omega$
$R_0^b = 100 \Omega$	$R_1^b = 100 \Omega$	$R_2^b = 10 \text{ k}\Omega$
	$R_1 = 10 \Omega$	$R_2 = 0 \Omega - 1 \text{ k}\Omega$

TABLE I

VALUES OF THE PARAMETERS USED FOR THE CIRCUIT OF FIG. 1.

*Proposition 2:* Let  $\hat{M} \in \mathbb{R}^{4 \times 4}$  be given by (\*) with all parameters finite and positive, and with  $\alpha_F, \alpha_R \in (0, 1)$ . Define

$$\begin{aligned} \gamma := & G_0^a G_0^b + (1-\alpha_F)(G_0^a G_2^b + G_0^b G_2^a + (1-\alpha_F)G_2^a G_2^b) \\ & + (1-\alpha_F)(G_0^a + (1-\alpha_F)G_2^a)G_1 \\ & - ((2\alpha_F - 1)G_1 - (1-\alpha_F)(G_0^b + (1-\alpha_F)G_2^b))G_2. \end{aligned} \quad (30)$$

If:

- $\gamma > 0$ , then the LCP( $\hat{M}, \hat{q}$ ) has a unique solution, regardless of  $\hat{q}$ .
- $\gamma < 0$ , then the LCP( $\hat{M}, \hat{q}$ ) may have a unique solution or three solutions, depending on the specific value of  $\hat{q}$ .
- $\gamma = 0$ , then  $\hat{M}$  is LCP-unstable.

*Proof:* Let  $\hat{\alpha}_0 = \{1, 3\}$ . After lengthy but simple computations, we find that the minor  $\det \hat{M}_{\hat{\alpha}_0, \hat{\alpha}_0} > 0$  if, and only if,  $\gamma > 0$ ; whereas the remaining principal minors are always positive. Thus, for  $\gamma > 0$ ,  $\hat{M}$  is a matrix of class  $P$  and the solution of the complementarity problem is unique, regardless of  $\hat{q}$ . If, on the other hand,  $\gamma < 0$ , then the conditions of Corollary 7 hold and the result follows. Finally, if  $\gamma = 0$ , then  $\hat{M}$  is degenerate and hence LCP-unstable. ■

For real transistors we have  $\alpha_F \in [0.8, 0.99]$  and  $\alpha_R \approx 0.5$  [38]. It thus follows that we can make  $\gamma < 0$  by setting  $G_1$  and  $G_2$  large enough, whenever the remaining conductances stay finite. Regarding the condition  $\hat{q} \in \text{int pos } C_{\hat{M}}(\hat{\alpha}_0)$  in Corollary 7, we will verify it numerically once the resistor parameters have been chosen. For concreteness, we consider all capacitors with the same value of  $100 \mu\text{F}$ ,  $\alpha_F = 0.99$ ,  $\alpha_R = 0.5$ , and  $s = 0.7$  V. The values of the resistances  $R_k^j$ ,  $k \in \{0, 1, 2\}$ ,  $j \in \{a, b\}$  are selected arbitrarily, whereas  $G_1$  is chosen in such a way that the factor associated with  $G_2$  in (30) is strictly negative. The chosen values are shown in Table I.

With the setting described in the previous paragraph, we can use  $G_2$  to set the sign of  $\gamma$ . Fig. 5 shows the region of the  $(R_2, r)$ -plane for which  $\gamma < 0$  and  $C_{\hat{M}}^{-1}(\hat{\alpha}_0)\hat{q} \in \text{int } \mathbb{R}_+^4$ . For instance, the parameters  $R_2 = 20 \Omega$  and  $r = 1.2$  V lie in the interior of the feasible region. It is easy to verify that, for the chosen parameters,  $\gamma < 0$  so, by Proposition 2, the LCP( $\hat{M}, \hat{q}$ ) has three solutions.

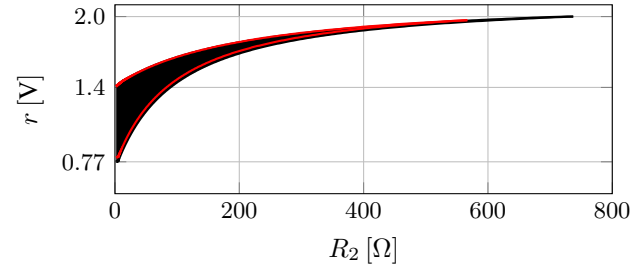

Fig. 5. Region of parameters (black-filled) in the  $(R_2, r)$ -plane for which  $\text{ind}_{\hat{M}}(x) = -1$ ,  $x \in \text{int pos } C_I(\hat{\alpha}_0)$  and  $\hat{q} \in \text{int pos } C_{\hat{M}}(\hat{\alpha}_0)$ . We have set  $\hat{M}$  as in (\*),  $\hat{\alpha}_0 = \{1, 3\}$  and used the parameters shown in Table I. The red line indicates the boundary of the feasible region for the original problem with  $D$  as in (8) and  $R_R = R_F = 1 \Omega$ .

For the parameters of Table I we have

$$N = -CA^{-1}B = \begin{bmatrix} 60.12 & -4.83 & 87.66 & -45.17 \\ 1.92 & 48.50 & 137.58 & -92.83 \\ 39.80 & 3.16 & 104.60 & -49.62 \\ 41.86 & -44.98 & -42.36 & 48.15 \end{bmatrix}. \quad (31)$$

It is a simple exercise to verify that all the minors of  $N$  are different from zero. Thus, it follows from Corollary 6 that  $N$  is LCP-stable. The solutions of the LCP( $\hat{M}, \hat{q}$ ) can be continuously mapped to the solutions of the original LCP( $M, q$ ) whenever  $\|D\|$  is small enough. For instance, the parameters  $R_R = R_F = 1 \Omega$  yield an  $R_0$ -matrix  $M$  such that  $\det M_{\alpha_0, \alpha_0} < 0$  and  $q \in \text{int } C_M(\alpha_0)$  with  $\alpha_0 = \{2, 4\}$ ; while the rest of the principal minors are positive. Therefore, by Corollary 7 there exists three equilibria for such parameters.

### C. Asymptotic properties of the circuit

It only rest to show that, with the chosen parameters, the network shows bistability. To that end, we use the recent approach of dominant systems developed in [47], [48]. Specifically, with our selection of parameters, the system (7a)-(7b) is strictly 1-passive from the “input”  $z$  to the “output”  $w$ . That is, it satisfies the  $\lambda$ -parameterized linear matrix inequality

$$\begin{bmatrix} A^\top P + PA + 2\lambda P + \varepsilon I & PB_1 - C^\top \\ B_1^\top P - C & -D - D^\top \end{bmatrix} \leq 0$$

for values of  $\lambda \in [105, 135]$  and

$$P = \begin{bmatrix} -1.87 & -5.96 & -2.42 & 3.65 \\ -5.96 & -5.66 & -5.90 & -0.18 \\ -2.42 & -5.90 & -0.86 & 4.42 \\ 3.65 & -0.18 & 4.42 & 4.67 \end{bmatrix} \times 10^{-3},$$

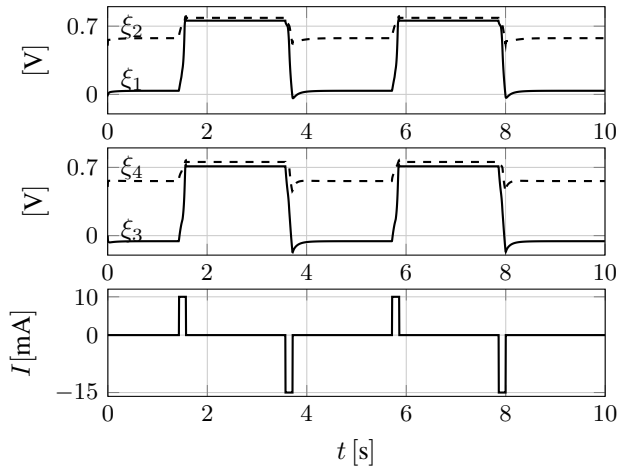

Fig. 6. Time trajectories of states  $\xi_1, \xi_2$  (top) and  $\xi_3, \xi_4$  (middle) of the circuit of Fig. 1. The extra current input  $I$  (bottom) confirms the bistable nature of the circuit.

which has inertia  $(1, 0, 3)$ . Now, since the complementarity condition (7c) is incrementally passive (0-passive in the language of [47]), we conclude that the closed-loop (7a)-(7c) is 1-passive with rate  $\lambda > 0$  and therefore 1-dominant. Hence, the asymptotic behavior of the network is topologically equivalent to the asymptotic behavior of a 1-dimensional system. Further, standard computations show that the trajectories are bounded and there is one unstable equilibrium, leading us to the desired conclusion. Fig. 6 shows the time evolution of the states of the network for the choice of parameters described above when an additional current source is connected between the terminals  $P_1 - P_0$ , confirming the desired bistable behavior.

### VIII. CLASSIFICATION OF TWO-DIMENSIONAL LCPS

In this section, we apply the results on LCP equivalence and stability in order to classify all possible cone configurations of 2-dimensional LCPS. Our incentive for studying such a low-dimensional problem in full detail comes from the fact that, in some cases, the singularities of an LCP can be assessed by studying a lower-dimensional one.

*Example 1:* Let

$$M = \begin{bmatrix} M_{11} & M_{12} \\ 0 & M_{22} \end{bmatrix} \quad \text{and} \quad q = \begin{bmatrix} q_1 \\ q_2 \end{bmatrix},$$

and consider a triangular LCP( $M, q$ ). Suppose that  $M_{22}$  is a  $P$ -matrix. Then,  $x_2$  is uniquely given by

$$x_2 = f_{M_{22}}^{-1}(q_2).$$

Moreover, since  $M_{22}$  is a  $P$ -matrix,  $f_{M_{22}}$  is regular. The problem can be then rewritten as

$$f_{M_{11}}(x_1) = \bar{q}_1, \quad \bar{q}_1 = M_{12}[-f_{M_{22}}^{-1}(q_2)]^+ + q_1,$$

from where we see that the nonsmooth singularities of the LCP( $M, q$ ) are determined by the nonsmooth singularities of the lower-dimensional LCP( $M_{11}, \bar{q}_1$ ).

Using the characterization of stable LCPS provided by Theorem 5, we start by enumerating all the unstable matrices. Such enumeration is performed by writing down all

the conditions leading to weakly degenerate matrices. For  $n = 2$ , such classification is relatively easy since, in  $\mathbb{R}^{2 \times 2}$ , weakly degenerate matrices either satisfy  $-M_{.,k} \in \text{pos } I_{.,k}$ , for  $k \in [1 \dots 2]$ , or they have degenerate complementary cones. Moreover, it follows from Corollary 3 that any matrix  $N \in \mathbb{R}^{2 \times 2}$  is LCP-equivalent to the matrix

$$M(\theta_1, \theta_2) = \begin{bmatrix} r_1 \cos(\theta_1 + \pi) & r_2 \cos(\theta_2 + \frac{3\pi}{2}) \\ r_1 \sin(\theta_1 + \pi) & r_2 \sin(\theta_2 + \frac{3\pi}{2}) \end{bmatrix}, \quad (32)$$

where  $r_1, r_2 \in \{0, 1\}$  and  $(\theta_1, \theta_2) \in [0, 2\pi) \times [0, 2\pi)$  are angles measured in counterclockwise direction with respect to the rays  $\text{pos } I_{.,1}$  and  $\text{pos } I_{.,2}$ , respectively. In what follows, we use the representation (32) for enumerating all  $2 \times 2$  unstable matrices. First we consider the class of strongly degenerate matrices, for which at least one column is zero. It is characterized by the conditions

$$\begin{aligned} r_1 r_2 &= 0 \\ (\theta_1, \theta_2) &\in [0, 2\pi) \times [0, 2\pi) \end{aligned} \quad (33)$$

The second class of unstable matrices encompasses the strongly degenerate matrices for which at least one complementary cone is a subspace of  $\mathbb{R}^n$ . This class is characterized by the conditions

$$\begin{aligned} r_1 &= r_2 = 1, \\ (\theta_1, \theta_2) &\in \Theta^+ \cup \left( \left\{ \frac{3\pi}{2} \right\} \times [0, 2\pi) \right) \\ &\quad \cup \left( [0, 2\pi) \times \left\{ \frac{\pi}{2} \right\} \right), \end{aligned} \quad (34)$$

where

$$\Theta^+ = \left\{ (\theta_1, \theta_2) \mid \theta_1 \in [0, 2\pi), \theta_2 = \left( \theta_1 + \frac{\pi}{2} \right) \bmod 2\pi \right\}.$$

Certainly, matrices satisfying either (33) or (34), lie outside of the  $R_0$ -class.

Finally, we consider the class of unstable  $R_0$ -matrices embracing the remaining degenerate and weakly degenerate matrices. This class is characterized by the conditions

$$\begin{aligned} r_1 &= r_2 = 1, \\ (\theta_1, \theta_2) &\in \Theta^- \cup \left( \left\{ \frac{\pi}{2} \right\} \times [0, 2\pi) \right) \\ &\quad \cup \left( [0, 2\pi) \times \left\{ \frac{3\pi}{2} \right\} \right), \end{aligned} \quad (35)$$

where

$$\Theta^- := \left\{ (\theta_1, \theta_2) \mid \theta_1 \in [0, 2\pi), \theta_2 = \left( \theta_1 - \frac{\pi}{2} \right) \bmod 2\pi \right\}.$$

The list of unstable normal forms complements the stable normal forms enumerated in [29]. However, the list (33)-(35) is more fundamental, in the sense that representatives of all stable classes can be obtained as perturbations of conditions (33)-(35).

Fig. 7 illustrates the partition of the space of  $2 \times 2$  matrices at different levels. Line segments and points with the same color, style and shape are LCP-equivalent. Unstable matrices satisfying (33), (34), and (35) are depicted using dotted, dashed, and solid lines, respectively. The double annular mark at the bottom left corner represents the zero matrix ( $r_1 =$



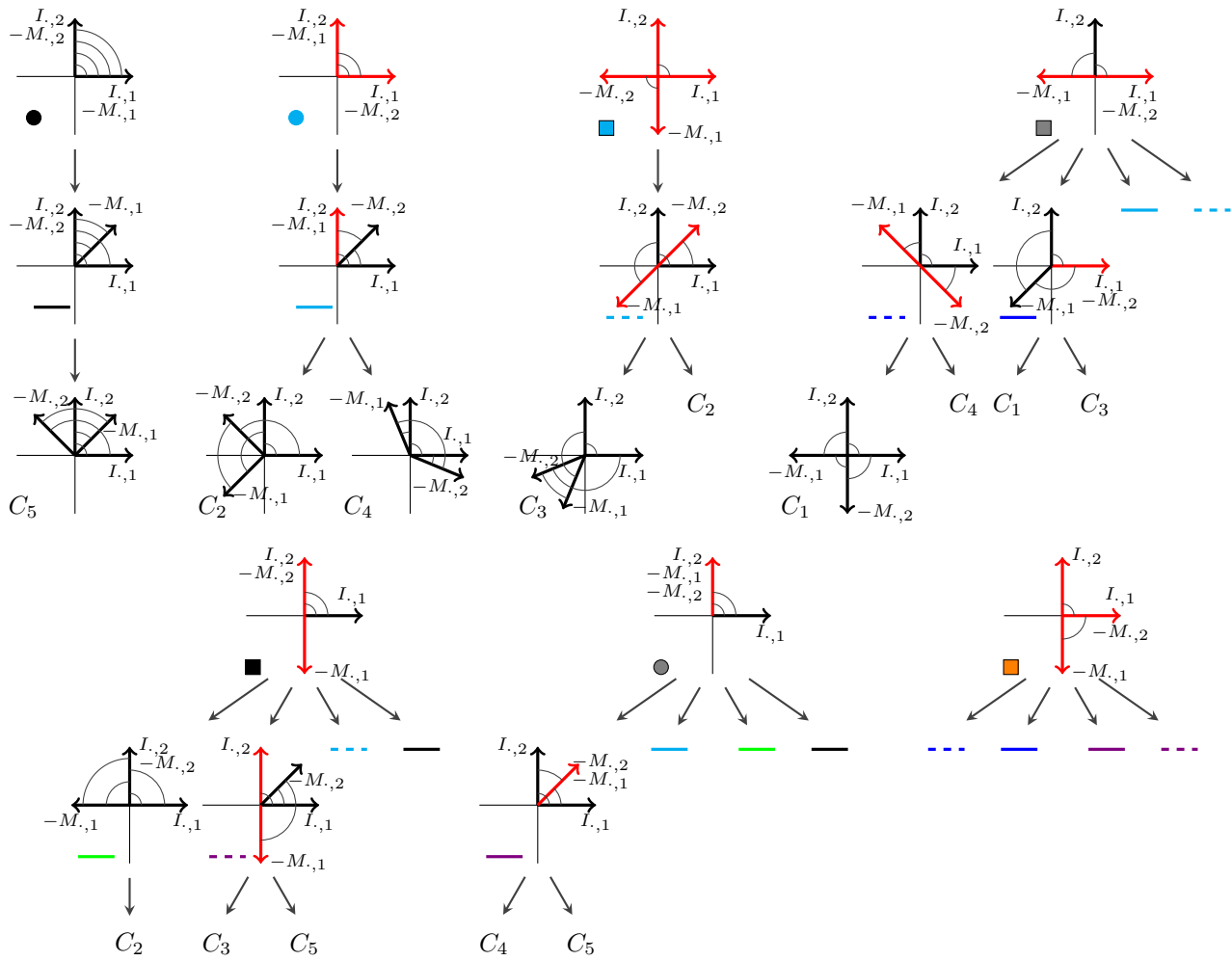

Fig. 8. Complementary cone configurations of representative members of the classes depicted in the central square in Fig. 7. Highly-degenerate configurations (circles and squares) break down into less-degenerate configurations (solid and dashed lines), which in turn break down into the stable configurations ( $C_1 - C_5$ ). Red rays denote degenerate cones.

[29] F. Castañós, F. A. Miranda-Villatoro, and A. Franci, "A notion of equivalence for linear complementarity problems with application to the design of non-smooth bifurcations," in *21st IFAC World Congress*, 2020.

[30] V. I. Arnold, A. N. Varchenko, and S. M. Gusein-Zade, *Singularities of Differentiable Maps*. Birkhäuser, 1985, vol. 1.

[31] M. Golubitsky and D. Schaeffer, *Singularities and Groups in Bifurcation Theory*, ser. Applied Mathematical Sciences. New York: Springer, 1985, vol. I.

[32] J. Guckenheimer and P. Holmes, *Nonlinear Oscillations, Dynamical Systems and Bifurcations of Vector Fields*. Springer-Verlag, 1983.

[33] L. O. Chua, J. Yu, and Y. Yu, "Negative resistance devices: Part I," *Circuit Theory and Applications*, vol. 11, pp. 161 – 186, 1983.

[34] R. A. Danao, "Q-matrices and boundedness of solutions to linear complementarity problems," *Journal of Optimization Theory and Applications*, vol. 83, no. 2, pp. 321–332, 1994.

[35] R. D. Doverspike, "Some perturbation results for the linear complementarity problem," *Mathematical Programming*, vol. 23, pp. 181 – 192, 1982.

[36] C. B. Garcia, F. J. Gould, and T. R. Turnbull, "Relations between PL maps, complementary cones, and degree in linear complementarity problems," in *Homotopy Methods and Global Convergence*, B. C. Eaves, F. J. Gould, H.-O. Peitgen, and M. J. Todd, Eds. Plenum Publishing Corporation, 1981, pp. 91–144.

[37] R. Howe and R. Stone, "Linear complementarity and the degree of mappings," in *Homotopy Methods and Global Convergence*, B. C. Eaves, F. J. Gould, H.-O. Peitgen, and M. J. Todd, Eds. Plenum Publishing Corporation, 1981, pp. 91–144.

[38] I. E. Getreu, *Modeling the Bipolar Transistor*. Amsterdam, The Netherlands: Elsevier Scientific Publishing Company, 1978.

[39] B. Brogliato and A. Tanwani, "Dynamical systems coupled with monotone set-valued operators: formalisms, applications, well-posedness, and stability," *SIAM Review*, vol. 62, no. 1, pp. 3 – 129, 2020.

[40] S. M. Robinson, "Strongly regular generalized equations," *Mathematics of Operations Research*, vol. 5, no. 1, 1980.

[41] M. Golubitsky and D. G. Schaeffer, *Singularities and Groups in Bifurcation Theory: Volume I*. Springer Science & Business Media, 1985, vol. 51.

[42] F. H. Clarke, *Optimization and nonsmooth analysis*. Society for Industrial and Applied Mathematics, 1990.

[43] S. Givant and P. R. Halmos, *Introduction to Boolean Algebras*. New York: Springer-Verlag, 2009.

[44] R. Sikorski, *Boolean Algebras*. Berlin, Germany: Springer-Verlag, 1969.

[45] H. Samelson, R. M. Thrall, and O. Wesler, "A partition theorem for Euclidean  $n$ -space," *Proceedings of the American Mathematical Society*, vol. 9, no. 5, pp. 805 – 807, 1958.

[46] R. G. Regis, "On the properties of positive spanning sets and positive bases," *Optimization and Engineering*, vol. 17, pp. 229 – 262, 2016.

[47] F. Forni and R. Sepulchre, "Differential dissipativity theory for dominance analysis," *IEEE Trans. Autom. Control*, vol. 64, pp. 2340 – 2351, 2019.

[48] F. A. Miranda-Villatoro, F. Forni, and R. Sepulchre, "Dominance analysis of linear complementarity systems," in *23rd International Symposium on Mathematical Theory of Networks and Systems*, 2018.