



HAL
open science

Equivalence of Linear Complementarity Problems: Theory and Application to Nonsmooth Bifurcations

Felix Miranda-Villatoro, Fernando Castaños, Alessio Franci

► **To cite this version:**

Felix Miranda-Villatoro, Fernando Castaños, Alessio Franci. Equivalence of Linear Complementarity Problems: Theory and Application to Nonsmooth Bifurcations. 2023. hal-03319638v2

HAL Id: hal-03319638

<https://inria.hal.science/hal-03319638v2>

Preprint submitted on 21 Mar 2023

HAL is a multi-disciplinary open access archive for the deposit and dissemination of scientific research documents, whether they are published or not. The documents may come from teaching and research institutions in France or abroad, or from public or private research centers.

L'archive ouverte pluridisciplinaire **HAL**, est destinée au dépôt et à la diffusion de documents scientifiques de niveau recherche, publiés ou non, émanant des établissements d'enseignement et de recherche français ou étrangers, des laboratoires publics ou privés.

EQUIVALENCE OF LINEAR COMPLEMENTARITY PROBLEMS: THEORY AND APPLICATION TO NONSMOOTH BIFURCATIONS

FÉLIX A. MIRANDA-VILLATORO, FERNANDO CASTAÑOS, AND ALESSIO FRANCI

ABSTRACT. Linear complementarity problems provide a powerful framework to model nonsmooth phenomena in a variety of real-world applications. In dynamical control systems, they appear coupled to a linear input-output system in the form of linear complementarity systems. Mimicking the general strategy that led to the foundation of bifurcation theory in smooth maps, we introduce a novel notion of equivalence between linear complementarity problems that sets the basis for a theory of bifurcations in a large class of nonsmooth maps, including, but not restricted to, steady-state bifurcations in linear complementarity systems. Our definition exploits the rich geometry of linear complementarity problems and leads to constructive algebraic conditions for identifying and classifying the nonsmooth singularities associated with nonsmooth bifurcations. We thoroughly illustrate our theory on an extended applied example, the design of bistability in an electrical network, and a more theoretical one, the identification and classification of all possible equivalence classes in two-dimensional linear complementarity problems.

1. INTRODUCTION

Complementarity conditions first appeared in the context of constrained optimization, in the form of the Karush-Kuhn-Tucker conditions to which the Lagrange multipliers are subject to [1]. Yet, complementarity conditions emerge naturally in many other modeling contexts including artificial intelligence, economics, and engineering. Electrical networks with semiconductor devices [2, 3, 4], mechanical systems with unilateral constraints [5], price equilibrium, traffic network [6], layers of ReLU nonlinearities used in deep neural networks [7], and portfolio selection problems [8] can all be modeled using a formalism in which decision variables must satisfy a set of complementarity conditions but the equations are otherwise linear. Linear complementarity problems (LCPs) are nonsmooth problems in which a set of complementarity conditions is coupled with a set of linear relations among the problem variables. Due to the broad spectrum of applications, complementarity problems (and LCPs in particular) have been extensively studied, see, e.g., [9, 10, 11, 12, 13, 14] and references therein. Complementarity problems appear in nonlinear control theory in the form of linear complementarity systems (LCSs), which are defined by coupling a set of complementarity conditions to an

Date: March 21, 2023.

Key words and phrases. Bifurcations, linear complementarity problems, nonsmooth dynamics, piecewise linear equations.

Félix A. Miranda-Villatoro is with the TRIPOP Team at the Centre de Recherche Inria de l'Université Grenoble-Alpes, LJK, 38000, Grenoble, France (e-mail: felix.miranda-villatoro@inria.fr).

Fernando Castaños is with the Departamento de Control Automático, Cinvestav-IPN, 2508 Av. IPN, 07360, Mexico City, Mexico (e-mail: fernando.castanos@cinvestav.mx).

Alessio Franci is with the Departamento de Matemáticas, Universidad Autónoma de México, Circuito exterior S/N, C.U., 04510. Mexico City, Mexico (e-mail: afranci@ciencias.unam.mx).

otherwise linear input–output control system, see, e.g., [15, 16, 17, 18]. Biological systems like gene and molecule regulatory networks [19] and neurons [20] can also be modeled as LCSs. Because of their nonlinear nature, LCSs can undergo bifurcations at which equilibria, limit cycles, or other types of steady-state solutions appear, disappear, or change stability. From a control-theoretical perspective, bifurcation theory is instrumental for two complementary reasons: stabilization, by avoiding the bifurcation through control [21, 22, 23, 24, 25], and realization of complex nonlinear behaviors, like neuro-inspired control system [26, 27, 28] or bio-inspired decision making [29, 30, 31, 32, 33], by exploiting the rigorously predictable nonlinear behaviors happening close to a bifurcation. Bifurcation theory is a key control-theoretical tool in all cases in which control systems must deal with behaviors beyond equilibrium stabilization. See, e.g., [34, Chapter 2]. Although non-smooth bifurcation problems have been studied in a variety of contexts (see, e.g., [35, 36] and references therein), a general bifurcation theory for LCSs is entirely undeveloped. Here, we elaborate on our preliminary results [37] and introduce novel theoretical tools to analyze and design the possible ways in which the set of solutions to an LCP changes as a function of control and system parameters. We propose these tools as candidates for the development of a non-smooth bifurcation theory for LCSs. As opposed to existing efforts in bifurcation theory for general non-smooth dynamical systems, focusing on specific, low-dimensional, examples in a piecemeal fashion, our goal is to develop a systematic theory amenable to general results. We propose LCSs as the framework in which to develop our theory because both mathematically tractable, due to the linear complementarity structure, and general, due to the fact that any smooth nonlinear vector field can be approximated (in the uniform metric) by a piece-wise linear one and, therefore [38], by an LCS. The first contribution of our paper is to show that equilibrium bifurcations (i.e., those bifurcations solely involving equilibrium points) of an LCS are fully characterized by the (nonsmooth) singularities of an auxiliary LCP. The second contribution of our paper is to introduce of a notion of equivalence between LCPs that allows us to characterize which LCPs are *LCP-stable*, i.e., those LCPs for which the geometry of the solution space is not destroyed by perturbations. This class of LCPs is particularly relevant in a control-theoretical setting because an associated LCS inherits this robustness. It is also crucial to study LCSs bifurcations, because problems that are not LCP-stable constitute degenerate situations akin to organizing bifurcations [39, 40] in smooth bifurcation theory. The theory is illustrated in details on practical and mathematical examples throughout the paper. With respect to the conference version [37] this paper: *i*) applies LCP singularity theory to LCS bifurcation theory, *ii*) provides both sufficient *and* necessary conditions for a matrix to be stable and it does so in arbitrary dimension, *iii*) uses the necessary and sufficient conditions for LCP-stability to list both LCP-stable *and* LCP-unstable 2×2 matrices, *iv*) introduces the notion of *weak convergence* and uses it for the computation of stability margins for LCPs, *v*) introduces the notion of one-parameter and multi-parameter bifurcation diagram for both LCPs and LCSs and computes them in various examples. The manuscript is organized as follows: Section 2 introduces the notation used in this work. LCSs are introduced in Section 3. Bifurcations in LCSs and their connection with LCP singularities, together with the needed background on LCPs, are introduced in Section 4. Sections 5 and 6 constitute the main technical body of the paper, where the notions of LCP-equivalence and LCP-stability are studied, and the main technical results are presented. Subsequently, the proposed framework is applied in Section 7 to the design of bistable LCSs and in Section 8 to the classification of two-dimensional LCPs.

2. NOTATION

Let X be a non-empty set. The power set of X is denoted as $\mathcal{P}(X)$. Whenever X is finite, $|X|$ denotes its cardinality. For a set $Y \subset X$, Y^c denotes its complement in X , $Y^c := X \setminus Y$. The notations $\text{int } Y$, $\text{bdr } Y$ and $\text{cl } Y$ stand for the interior, the boundary and the closure of Y , respectively. Given an integer n , we use $[1 \dots n]$ to denote the interval of all integers between 1 and n . We endow all subsets of \mathbb{N} with the natural order. Let $A \in \mathbb{R}^{n \times m}$, $\alpha \subseteq [1 \dots n]$, and $\beta \subseteq [1 \dots m]$. The submatrix $A_{\alpha, \beta} \in \mathbb{R}^{|\alpha| \times |\beta|}$ is the matrix $[A_{ij}]_{i \in \alpha, j \in \beta}$. The notation $A_{\cdot, \beta}$ stands for the submatrix $A_{[1 \dots n], \beta}$. We omit the braces whenever β is a singleton, that is, $A_{\cdot, j} = A_{\cdot, \{j\}}$. The (polyhedral) cone generated by A is the set of all positive linear combinations of the columns of A , that is,

$$\text{pos } A := \left\{ x = \sum_{j=1}^m p_j A_{\cdot, j} \mid p_j \geq 0, j \in [1 \dots m] \right\}.$$

The columns of A are the *generators* of $\text{pos } A$. The cone $\text{pos } A$ is said to be *pointed* if there is no non-trivial subspace contained in it, whereas it is said to be *strictly pointed* if $\ker(A) \cap \mathbb{R}_+^m = \{0\}$, where

$$\mathbb{R}_+^m := \{x \in \mathbb{R}^m \mid x_i \geq 0, i \in [1 \dots m]\}$$

denotes the positive orthant of \mathbb{R}^m and $\ker(A)$ is the null space of A . Finally, we denote the projection of $x \in \mathbb{R}^n$ onto the positive orthant \mathbb{R}_+^n by $[x]^+$, that is,

$$[x]^+ := \arg \min_{w \in \mathbb{R}_+^n} \frac{1}{2} \|x - w\|^2.$$

3. LINEAR COMPLEMENTARITY SYSTEMS

Let us start with a formal definition of the linear complementarity problem.

Definition 3.1. Given a matrix $M \in \mathbb{R}^{n \times n}$ and a vector $q \in \mathbb{R}^n$, the *linear complementarity problem* $\text{LCP}(M, q)$ consists in finding a vector $z \in \mathbb{R}^n$ such that

$$(3.1) \quad \mathbb{R}_+^n \ni Mz + q \perp z \in \mathbb{R}_+^n.$$

Condition (3.1) is called the *complementarity condition*, it is the compact form of the following three conditions: 1) $Mz + q \in \mathbb{R}_+^n$, 2) $z \in \mathbb{R}_+^n$, and 3) $(Mz + q)^\top z = 0$. An LCS is a linear system coupled to an LCP, i.e., a system of the form

$$(3.2a) \quad \dot{\xi}(t) = A\xi(t) + Bz(t) + E_1 r,$$

$$(3.2b) \quad w(t) = C\xi(t) + Dz(t) + E_2 s,$$

$$(3.2c) \quad \mathbb{R}_+^m \ni w(t) \perp z(t) \in \mathbb{R}_+^m,$$

where $\xi(t) \in \mathbb{R}^n$ is the state of the system at time t , $z(t)$, $w(t) \in \mathbb{R}^m$ are the so-called complementary variables (they can be interpreted as external port variables), and $r \in \mathbb{R}^l$, $s \in \mathbb{R}^l$ are vectors of parameters. The matrices A, B, C, D, E_1 and E_2 are constant and of appropriate dimensions. It is noteworthy that, even though the right-hand sides of (3.2a)-(3.2b) are affine functions of the state, the time evolution of the state in (3.2) is, in general, nonlinear (and nonsmooth) due to the complementarity condition (3.2c). In practice, complementarity systems such as (3.2) arise naturally in different fields such as contact mechanics [5], electronics [2, 3], mathematical biology [41], finance [8], etc. Moreover, in the context of control systems, Lur'e systems with piecewise-linear or relay-type feedback also can be written within the formalism of LCSs. As an illustration, let us consider the

piecewise-linear chaotic Rössler-like circuit [42]

$$\begin{aligned}\dot{\xi}(t) &= A\xi(t) + Bg(y(t)) \\ y(t) &= C\xi(t) \\ g(y(t)) &= \begin{cases} 0 & \text{if } y(t) \leq 3 \\ \mu(y(t) - 3) & \text{if } y(t) > 3 \end{cases},\end{aligned}$$

which can be written using complementary variables as,

$$\begin{aligned}\dot{\xi}(t) &= A\xi(t) + Bz(t) \\ w(t) &= -\mu C\xi(t) + z(t) + 3\mu \\ 0 &\leq w(t) \perp z(t) \geq 0.\end{aligned}$$

The fact that the piecewise-linear function g above can be written in the complementarity formalism is not a coincidence. Indeed, there is a close relationship between piecewise-linear maps and linear complementarity problems, so that (under mild regularity assumptions) any continuous piecewise-linear map can be written as the solution of an LCP [38, 43]. This property, together with the fact that the set of piecewise-linear functions is dense in the set of continuous functions with compact domain, gives LCSs a powerful framework for approximating complicated nonlinear phenomena. Besides continuous piecewise-linear feedback laws, it is also possible to model some set-valued maps. Consider, for instance, the LCS

$$(3.3a) \quad \dot{\xi}(t) = A\xi(t) + B \begin{bmatrix} 1 & -1 \end{bmatrix} z(t)$$

$$(3.3b) \quad w(t) = \begin{bmatrix} 1 & 1 \\ 1 & 1 \end{bmatrix} z(t) + \begin{bmatrix} 1 \\ -1 \end{bmatrix} C\xi(t) + \begin{bmatrix} -1 \\ -1 \end{bmatrix}$$

$$(3.3c) \quad \mathbb{R}_+^2 \ni w(t) \perp z(t) \in \mathbb{R}_+^2.$$

The LCP (3.3b)-(3.3c) has the solution

$$z(t) = \begin{bmatrix} 1 - C\xi(t) \\ 0 \end{bmatrix} \quad \text{if } C\xi(t) < 0, \quad z(t) = \begin{bmatrix} 0 \\ 1 + C\xi(t) \end{bmatrix} \quad \text{if } C\xi(t) > 0,$$

and

$$z(t) \in \left\{ \begin{bmatrix} 1 + \theta \\ -\theta \end{bmatrix}, \theta \in [-1, 0] \right\}, \quad \text{if } C\xi(t) = 0.$$

Hence,

$$\begin{bmatrix} 1 & -1 \end{bmatrix} z(t) \in -C\xi(t) - \text{Sgn}(C\xi(t)),$$

where $\text{Sgn} : \mathbb{R} \rightrightarrows [-1, 1]$ is the set-valued sign map

$$\text{Sgn}(x) = \begin{cases} -1 & \text{if } x < 0 \\ [-1, 1] & \text{if } x = 0 \\ 1 & \text{if } x > 0 \end{cases}.$$

Therefore, Eq. (3.3) is just another representation of a linear system with set-valued feedback, as those studied in set-valued sliding-mode control [44, 45]. Since the complementarity condition (3.2c) is equivalent to the inclusion

$$-z(t) \in \mathbf{N}_{\mathbb{R}_+^m}(w(t))$$

with $\mathbf{N}_S : S \rightrightarrows \mathbb{R}^n$ the normal cone to the set S [13, Proposition 1.1.3], the LCS (3.2) encompasses systems with state constraints [46]. In particular, when $D = 0$, Eq. (3.2) becomes

$$(3.4) \quad \dot{\xi}(t) \in A\xi(t) - B\mathbf{N}_{\mathbb{R}_+^m}(C\xi(t) + E_2s) + E_1r.$$

For the system to be well-defined, the trajectories of (3.4) must satisfy the state constraint $C\xi(t) + E_2s \in \mathbb{R}_+^m$ at all times t . An important difference between the

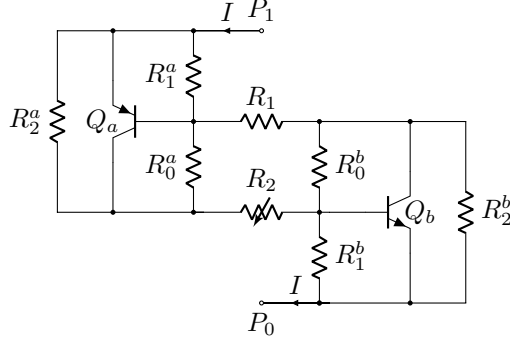

FIGURE 1. Feedback interconnection of PNP and NPN transistors showing differential negative resistance between terminals P_1 and P_0 .

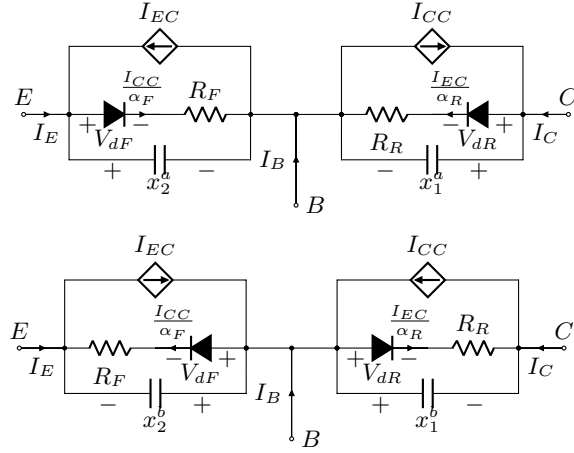

FIGURE 2. Ebers-Moll model of bipolar junction transistors. PNP transistor (above), and NPN transistor (below).

differential inclusions (3.4) and (3.3) is that the former is not of Filippov type, as the normal cone \mathbf{N}_S is not bounded at points on $\text{bdr } S$. We see that the set of possible behaviors of an LCS is broad enough to model a variety of nonlinear phenomena involving multiple equilibria, limit cycles, sliding modes, state constraints, and chaotic behavior, to mention a few.

LCS model of a circuit with bipolar transistors. Motivated by the work of Chua *et al.* on negative resistance devices [47], we consider the circuit in Fig. 1. The circuit topology is fairly general as, by opening or short-circuiting some of the resistors, it is possible to recover many of the circuits considered in [47]. This circuit is chosen as a practically relevant running example to illustrate the theory developed throughout the paper but all the results are general and many other systems, including mechanical or biological ones, could have been chosen to this purpose. The circuit contains two bipolar junction transistors (BJTs) that we describe using a dynamical version of the Ebers-Moll model depicted in Fig. 2 (see, e.g., [48]), where each capacitor models the charge storage effects of the P-N and N-P junctions. Each diode in Fig. 2 satisfies the complementarity condition

$$0 \leq I_d \perp (V^* - V_d) \geq 0,$$

where I_d is the current flowing through the diode, V_d is the voltage across its terminals, and V^* is the forward voltage of the diode (typically between 0.3 V–0.7 V). After the application of Kirchoff's laws, we realize that the circuit evolves according to (3.2a)–(3.2c) with state $\xi = [x_1^a, x_2^a, x_1^b, x_2^b]^\top \in \mathbb{R}^4$. Here, x_k^a and x_k^b , $k \in \{1, 2\}$, are the voltages across the capacitors of the transistors Q_a and Q_b , respectively (see Fig. 2). The complementary variables are given by $z = [I_{EC}^a, I_{CC}^a, I_{EC}^b, I_{CC}^b] \in \mathbb{R}^4$ and $w = [V^* - V_{dR}^a, V^* - V_{dF}^a, V^* - V_{dR}^b, V^* - V_{dF}^b]^\top \in \mathbb{R}^4$. We have the parameters $s = V^*$ and $r = P_1 - P_0$, the latter being the potential difference across the terminals shown in Fig. 1. The remaining parameters are

$$(3.5) \quad \begin{aligned} A &= Q \begin{bmatrix} A_{1,1} & A_{1,2} \\ A_{1,1}^\top & A_{2,2} \end{bmatrix}, \quad B = Q \begin{bmatrix} T & 0 \\ 0 & T \end{bmatrix}, \\ E_1 &= Q[-G_2, G_1 + G_2, -G_1, G_1 + G_2]^\top, \quad E_2 = \mathbf{1}_4, \\ Q &= \text{Diag} \left(\frac{1}{C_1^a}, \frac{1}{C_2^a}, \frac{1}{C_1^b}, \frac{1}{C_2^b} \right), \quad C = -I_4, \\ D &= \text{Diag} \left(\frac{R_R}{\alpha_R}, \frac{R_F}{\alpha_F}, \frac{R_R}{\alpha_R}, \frac{R_F}{\alpha_F} \right), \end{aligned}$$

where $\mathbf{1}_4 \in \mathbb{R}^4$ is a vector of ones and

$$(3.6) \quad \begin{aligned} A_{1,1} &= \begin{bmatrix} -(G_0^a + G_2^a + G_2) & G_2^a + G_2 \\ G_2^a + G_2 & -(G_1^a + G_2^a + G_1 + G_2) \end{bmatrix}, \\ A_{2,2} &= \begin{bmatrix} -(G_0^b + G_2^b + G_1) & G_2^b + G_1 \\ G_2^b + G_1 & -(G_1^b + G_2^b + G_1 + G_2) \end{bmatrix}, \\ A_{1,2} &= \begin{bmatrix} 0 & G_2 \\ G_1 & -(G_1 + G_2) \end{bmatrix}, \quad T = \begin{bmatrix} -\frac{1}{\alpha_R} & 1 \\ 1 & -\frac{1}{\alpha_F} \end{bmatrix}, \end{aligned}$$

with $G_k^j = 1/R_k^j$, $k \in \{1, 2\}$, $j \in \{a, b\}$. Finally, $\alpha_F, \alpha_R \in (0, 1)$ are the forward and reverse gains of the bipolar transistors.

4. BIFURCATIONS IN LINEAR COMPLEMENTARITY SYSTEMS

In this section, we recall some facts about the solutions to LCPs and propose a procedure for detecting bifurcations in LCSs.

4.1. Background on LCPs. Linear complementarity problems have a rich geometric structure that determines the properties of their solution set. In what follows, we introduce the necessary elements for the geometric analysis of LCPs.

Definition 4.1. Given an LCP(M, q) and a subset $\alpha \subseteq [1 \dots n]$. The *complementary matrix* $C_M(\alpha) \in \mathbb{R}^{n \times n}$ is the matrix whose columns are

$$(4.1) \quad C_M(\alpha)_{\cdot, j} = \begin{cases} -M_{\cdot, j} & j \in \alpha \\ I_{\cdot, j} & j \notin \alpha \end{cases}.$$

The cone generated by $C_M(\alpha)$, $\text{pos } C_M(\alpha)$, is called a *complementary cone* of M .

A *facet* of $\text{pos } C_M(\alpha)$ is an $(n - 1)$ -dimensional face of the form

$$\text{pos } C_M(\alpha)_{\cdot, i^c}$$

for some $i \in [1 \dots n]$ and i^c the complement of $\{i\}$ in $[1 \dots n]$. In what follows, $\mathcal{K}(M)$ denotes the union of all facets of the complementary cones of $M \in \mathbb{R}^{n \times n}$. The complementary cone $\text{pos } C_M(\alpha)$ is called *non-degenerate* if it is solid, that is, if $C_M(\alpha)$ is nonsingular. Otherwise, $\text{pos } C_M(\alpha)$ is called *degenerate*.

Definition 4.2. A matrix $M \in \mathbb{R}^{n \times n}$ is said to be *non-degenerate* if all its complementary cones, $\text{pos } C_M(\alpha)$, $\alpha \subseteq [1 \dots n]$ are non-degenerate.

Definition 4.3 ([49, 50]). We say that $M \in \mathbb{R}^{n \times n}$ belongs to the class R_0 if, for each $\alpha \subseteq [1 \dots n]$, we have $\ker(C_M(\alpha)) \cap \mathbb{R}_+^n = \{0\}$.

The previous definition implies that all the complementary cones are strictly pointed, that is, that M does not have zero columns nor complementary cones that are subspaces [14, Thm. 6.1.19]. Now we define the piecewise linear map $f_M : \mathbb{R}^n \rightarrow \mathbb{R}^n$ as

$$(4.2) \quad f_M(x) := C_{-M}(\alpha)x \quad \text{for } x \in \text{pos } C_I(\alpha).$$

Note that the cones $\text{pos } C_I(\alpha)$ are the 2^n orthants in \mathbb{R}^n , so f_M is defined orthant-wise and $\alpha \subseteq [1 \dots n]$ is simply a placeholder used for indexing each orthant. Also, mark that

$$(4.3) \quad f_M(\text{pos } C_I(\alpha)) = \text{pos } C_M(\alpha).$$

Theorem 4.4 ([14]). Let $z \in \mathbb{R}_+^n$ be a solution to the LCP(M, q). Then, $x = (M - I_n)z + q$ is a solution to the equation

$$(4.4) \quad f_M(x) - q = 0.$$

Conversely, if $x \in \mathbb{R}^n$ is a solution to (4.4), then $z = [-x]^+$ is a solution to the LCP(M, q).

It follows that the LCP(M, q) and the problem (4.4) are equivalent in the sense that we only need to know the solutions to one of them in order to know the solutions to the other. The functional representation (4.4) lends itself to the application of degree theory.

Definition 4.5. Let $M \in \mathbb{R}^{n \times n}$ be an R_0 -matrix and $x \in \mathbb{R}^n$ be in the interior of $\text{pos } C_I(\alpha)$ for some $\alpha \subseteq [1 \dots n]$. The *index* of f_M at x , denoted as $\text{ind}_M(x)$, is given by

$$\text{ind}_M(x) = \text{sgn}(\det M_{\alpha, \alpha}).$$

By convention, if $\alpha = \emptyset$, then $\text{ind}_M(x) = 1$.

Definition 4.6. Let $M \in \mathbb{R}^{n \times n}$ be an R_0 -matrix and let $q \in \mathbb{R}^n$ be such that $f_M^{-1}(q)$ consists of finitely many points and $\text{ind}_M(x)$ is well-defined for all $x \in f_M^{-1}(q)$. The *degree* of f_M at q , denoted as $\text{deg}_M(q)$ is

$$\text{deg}_M(q) = \sum_{x \in f_M^{-1}(q)} \text{ind}_M(x).$$

Note that, for a given $\alpha \subseteq [1 \dots n]$, the index of f_M at x is the same for all $x \in \text{int pos } C_I(\alpha)$ so, there are as many indices as there are subsets in $[1 \dots n]$. For matrices in the class R_0 , the degree is the same for any $q \notin \mathcal{K}(M)$ [14, Theorem 6.1.14]. Thus, for R_0 -matrices the degree is global and one only needs to test one point $q \notin \mathcal{K}(M)$. The reader is addressed to [14, 51, 52] and references therein for a detailed account of degree theory in the context of complementarity problems. The solutions to the LCP(M, q) depend on the geometry of the complementary cones $\text{pos } C_M(\alpha)$. More precisely, there exists at least one solution x of (4.2) for every $\alpha \subseteq [1 \dots n]$ such that $q \in \text{pos } C_M(\alpha)$. If $C_M(\alpha)$ is nonsingular the associated solution is unique, whereas there exists a continuum of solutions if $C_M(\alpha)$ is singular. Thus, for a given q , there can be no solutions, there can be one solution, multiple isolated solutions, or a continuum of solutions, depending on how many complementary cones q belongs to and what the properties of these cones are. We will later make use of an alternative representation of f_M .

Lemma 4.7. The map (4.2) can also be written as

$$(4.5) \quad f_M(x) = [x]^+ - M[-x]^+.$$

4.2. LCS bifurcations are determined by LCP singularities. The main issues addressed in the literature about LCS are well-posedness and asymptotic behavior of the resulting trajectories (see, e.g., [18, 45, 17, 16, 15]). If D is a P -matrix (i.e., all its principal minors are positive) then, the inverse f_D^{-1} is well-defined [14, Theorem 3.3.7], so for every ξ and s , there exists a unique z satisfying (3.2b)-(3.2c) and given by

$$(4.6) \quad z = [-f_D^{-1}(C\xi + E_2s)]^+ .$$

Substituting (4.6) in (3.2a), (3.2) can be written explicitly as

$$(4.7) \quad \dot{\xi}(t) = F(\xi(t), r, s)$$

with

$$(4.8) \quad F(\xi, r, s) = A\xi + B[-f_D^{-1}(C\xi + E_2s)]^+ + E_1r .$$

Furthermore, it can be readily shown that F is globally Lipschitz-continuous in ξ [53], so that (3.2) is well posed, i.e., its solutions are global and unique. A less-explored problem is understanding how the equilibria of (3.2) change, appear, and disappear as a function of the input parameters r and s , that is, what is the nonsmooth equilibrium bifurcation structure of (3.2). The following definition formalizes the notion of non-smooth equilibrium bifurcation. It uses a notion of regularity that is closely related to that proposed in [54] and it is inspired by the notion of smooth equilibrium bifurcation used in [39].

Definition 4.8. Given a Lipschitz-continuous map depending on m parameters, $g : \mathbb{R}^n \times \mathbb{R}^m \rightarrow \mathbb{R}^n$, a point (y_0, p_0) is a *regular solution* of g if $g(y_0, p_0) = 0$ and there exists a neighborhood $W = U \times V$ of (y_0, p_0) such that the map $p \mapsto \{y \in U \mid g(y, p) = 0\}$ is single-valued and Lipschitz-continuous over V^1 . Solutions of $g(y, p) = 0$ that are not regular are called *bifurcations* of g .

Let $\partial_y g(y, p)$ denote the Clarke generalized Jacobian of g with respect to y at (y, p) , that is,

$$\partial_y g(y, p) = \text{co} \left\{ \lim_{i \rightarrow \infty} D_y g(y_i, p) \mid y_i \rightarrow y, y_i \notin \Omega_g \right\} ,$$

where Ω_g is the set of measure zero where the Jacobian $D_y g$ of the Lipschitz-continuous map g does not exist. We say that $\partial_y g(y, p)$ is of *maximal rank*, or *nonsingular*, if every matrix in $\partial_y g(y, p)$ is nonsingular. Conversely, we say that $\partial_y g(y, p)$ is singular if it contains a singular matrix. The following proposition is a direct consequence of the nonsmooth Implicit Function Theorem [55, p. 256].

Proposition 4.9. *If (y_0, p_0) is a bifurcation of g then $\partial_y g(y_0, p_0)$ is singular.*

The following theorem shows that equilibria of (3.2) can be put in one-to-one correspondence with the solution of an associated LCP.

Theorem 4.10. *Consider (3.2) with D a P -matrix and A nonsingular, and define*

$$(4.9a) \quad M = D - CA^{-1}B$$

$$(4.9b) \quad \bar{q}(r, s) = E_2s - CA^{-1}E_1r .$$

If ξ^ is an equilibrium of (4.7), then $x^* = X(\xi^*, s)$ with*

$$(4.10) \quad X(\xi, s) = f_D^{-1}(C\xi + E_2s)$$

¹To simplify the exposition, a multi-valued map whose image is a singleton will be treated as a single-valued map.

is a solution of $f_M(x^*) = \bar{q}(r, s)$. Conversely, if x^* is a solution of $f_M(x^*) = \bar{q}(r, s)$, then $\xi^* = \Xi(x^*, r)$ with

$$(4.11) \quad \Xi(x, r) = -A^{-1} (B[-x]^+ + E_1 r)$$

is an equilibrium of (4.7).

Corollary 4.11. *Under the same assumptions and definitions used in Theorem 4.10, the point (ξ_0, r_0, s_0) is a bifurcation of F if, and only if, $(x_0, q_0) = (X(\xi_0, s_0), \bar{q}(r_0, s_0))$ is a bifurcation of $(x, q) \mapsto f_M(x) - q$.*

It follows that the steady-state bifurcations of an LCS are characterized by the bifurcations of an associated LCP. Furthermore, by Proposition 4.9, we can make two key observations. First, LCS bifurcations are non-hyperbolic equilibria of (3.2), in the sense that Jacobian $\partial_\xi F(\xi, r, s)$ at a bifurcation point contains matrices with some zero eigenvalues. As such, system (3.2) can lose stability at bifurcations. Second, bifurcations of an LCP can be found constructively by looking for its *singularities*, i.e., points (x_0, q_0) such that $f_M(x_0) - q_0 = 0$ and $\partial_x f_M(x_0)$ is singular. Observing that

$$\partial f_M(x) = \text{co} \{C_{-M}(\alpha) \mid x \in \text{pos } C_I(\alpha)\} ,$$

it follows that $\partial f_M(x)$ is a singleton whenever x belongs to the interior of an orthant and a set of matrices whenever x belongs to the common boundary of two or more orthants. Hence, for a point (x_0, q_0) to be a nonsmooth singularity of the LCP(M, q) it is necessary that, for some $\alpha \subseteq [1 \dots n]$, either $x_0 \in \text{bdr pos } C_I(\alpha)$ or $x_0 \in \text{int pos } C_I(\alpha)$ with $C_{-M}(\alpha)$ singular. In the former case ∂f_M is a set for which the maximal rank condition may not hold, whereas in the latter case ∂f_M is a singular matrix and therefore it is not of maximal rank. Note that, in both cases, $q_0 \in \text{bdr } C_M(\alpha)$. Therefore, nonsmooth bifurcations in LCPs are essentially determined by the configuration of the complementarity cones and how q moves across them. In practice, the *path* traced by q depends on control (or *bifurcation*) parameters $\lambda \in \mathbb{R}^l$. That is, $q = \bar{q}(\lambda)$ where $\bar{q} : \mathbb{R}^l \rightarrow \mathbb{R}^n$ is assumed continuous. Thereby, as λ changes, the number of solutions of the LCP might change depending on the properties and the number of complementary cones that $\bar{q}(\lambda)$ traverses. A *bifurcation diagram* is a graphical representation of how equilibrium solutions change as a function of λ . The notion of equivalence for LCPs introduced in the next section helps in the task of analyzing and classifying complementarity-cone configurations (and therefore LCP singularities and associated LCS bifurcations), as illustrated through both applied and theoretical extended examples.

5. EQUIVALENCE OF LCPS

Our notion of equivalence between an LCP(M, q) and an LCP(N, r) involves both topological and algebraic properties. The algebraic properties deal with the relations among the complementary cones of M and N . The relevant algebraic structure is that of a Boolean algebra, a subject that we now briefly recall (see [56, 57] for more details).

Definition 5.1. Let X be a set. A *field of sets* is a pair (X, \mathcal{F}) , where $\mathcal{F} \subseteq \mathcal{P}(X)$ is any non-empty family of sets that is closed under the set operations of complement and finite union.

It follows easily from the De Morgan rules that a field of sets (X, \mathcal{F}) is also closed under finite intersections of sets. Note also that \emptyset and X are always members of \mathcal{F} . In the cases when the set X is clear from the context, we will denote the field of sets simply by the collection \mathcal{F} . Fields of sets are concrete examples of Boolean algebras, see, e.g., [57]. Therefore, the usual algebraic concepts apply to them.

Definition 5.2. Consider the fields (X, \mathcal{F}) and $(\hat{X}, \hat{\mathcal{F}})$. A mapping $h : \mathcal{F} \rightarrow \hat{\mathcal{F}}$ is said to be *Boolean* if, for all $P_1, P_2 \in \mathcal{F}$,

$$h(P_1 \cap P_2) = h(P_1) \cap h(P_2)$$

and

$$h(X \setminus P_1) = \hat{X} \setminus h(P_1).$$

A Boolean map that is also a bijection is said to be a *Boolean isomorphism*. A Boolean isomorphism that maps a field of sets to itself is said to be a *Boolean automorphism*.

Definition 5.3. A map $\varphi_* : \mathcal{F} \rightarrow \hat{\mathcal{F}}$ is said to be *induced* by a map $\varphi : \hat{X} \rightarrow X$ if, for every set $P \in \mathcal{F}$,

$$\varphi_*(P) = \varphi^{-1}(P).$$

Let $\mathcal{G} \subseteq \mathcal{P}(X)$. The field of sets *generated* by \mathcal{G} , denoted $\text{span } \mathcal{G}$, is the intersection of all the fields of sets containing \mathcal{G} . That is, it is the smallest field of sets containing \mathcal{G} . In what follows, we consider the collection of complementary cones $\mathcal{G}_M = \{\text{pos } C_M(\alpha)\}_\alpha$ and we denote the field of sets generated by \mathcal{G}_M as \mathcal{F}_M . We are now ready to introduce our main definition.

Definition 5.4. Two matrices $M, N \in \mathbb{R}^{n \times n}$ are *LCP-equivalent*, denoted $M \sim N$, if the fields of sets \mathcal{F}_M and \mathcal{F}_N are isomorphic and the Boolean isomorphism $\varphi_* : \mathcal{F}_M \rightarrow \mathcal{F}_N$ is induced by a homeomorphism $\varphi : \mathbb{R}^n \rightarrow \mathbb{R}^n$.

In other words, two matrices are LCP-equivalent if the Boolean structures of their associated complementary cones are isomorphic. That is, if there is a bijection $\varphi_* : \mathcal{F}_M \rightarrow \mathcal{F}_N$ preserving intersections, unions, and complements of complementary cones. Since φ_* is required to be induced by a homeomorphism, it suffices to verify that φ induces a bijection from \mathcal{G}_M to \mathcal{G}_N [37, Cor. 12]. As an illustration, let us consider the matrices

$$(5.1) \quad M = \begin{bmatrix} 1 & 1 \\ 1 & 1 \end{bmatrix} \quad \text{and} \quad N = \begin{bmatrix} 1 & -1 \\ 1 & 0 \end{bmatrix}.$$

The associated complementary cones and illustrative LCP bifurcation diagrams are depicted in Fig. 3. Note that, although M is singular and N is not, they are in fact LCP-equivalent. To see this, consider the homeomorphism $\varphi : \mathbb{R}^2 \rightarrow \mathbb{R}^2$,

$$\varphi(q') = \begin{bmatrix} -1 & 0 \\ -1 & 1 \end{bmatrix} q'.$$

Simple but lengthy computations show that

$$\varphi_* : \text{pos } C_M(\alpha) \mapsto \text{pos } C_N(\beta(\alpha))$$

with $\beta : \mathcal{P}([1 \dots n]) \rightarrow \mathcal{P}([1 \dots n])$ given by

$$\emptyset \mapsto \{1\}, \quad \{1\} \mapsto \emptyset, \quad \{2\} \mapsto \{1, 2\}, \quad \{1, 2\} \mapsto \{2\}.$$

That is, φ induces a bijection $\mathcal{G}_M \rightarrow \mathcal{G}_N$ and hence an isomorphism $\mathcal{F}_M \rightarrow \mathcal{F}_N$. LCP-equivalence ensures that the two problems have similar bifurcation diagrams in all cases in which the bifurcation parameter paths in the two problems traverse isomorphic complementarity cones. This is the case of the example in Fig. 3, which leads in both problems to a continuous bifurcation diagram characterized by the transition from one to an infinity (at the crossing of the degenerate cone) to one solution. The notion of equivalence between bifurcation diagrams will be formalized in future works.

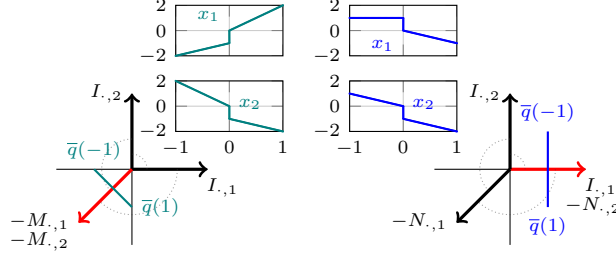

FIGURE 3. Complementary cones associated with the matrices M (left) and N (right) from (5.1). Red rays denote degenerate complementary cones, whereas the line segments denote the path \bar{q} . The boxes show the associated LCP bifurcation diagrams for the two affine paths indicated by the thin gray (left) and thin blue (right) line, respectively.

Theorem 5.5. Consider two matrices $M, N \in \mathbb{R}^{n \times n}$ and suppose there exists homeomorphisms $\varphi, \psi : \mathbb{R}^n \rightarrow \mathbb{R}^n$ such that

$$(5.2) \quad f_M = \varphi \circ f_N \circ \psi,$$

where ψ induces a Boolean automorphism on \mathcal{F}_I . Then, $M \sim N$.

There is a slightly weaker converse result.

Theorem 5.6. Consider two non-degenerate matrices $M, N \in \mathbb{R}^{n \times n}$ and suppose that $M \sim N$ with homeomorphism φ . Then, there exists another homeomorphism $\psi : \mathbb{R}^n \rightarrow \mathbb{R}^n$ that induces an automorphism $\psi_* : \mathcal{F}_I \rightarrow \mathcal{F}_I$ and such that (5.2) holds.

Condition (5.2) is the commutative diagram

$$\begin{array}{ccc} \mathbb{R}^n & \xrightarrow{\psi} & \mathbb{R}^n \\ f_M \downarrow & & \downarrow f_N \\ \mathbb{R}^n & \xleftarrow{\varphi} & \mathbb{R}^n \end{array}.$$

It is standard in the literature of singularity theory [58] and ensures that we can continuously map solutions of the problem $f_M(x) = q$ into solutions of the problem $f_N(x') = \varphi^{-1}(q)$. The requirement on ψ being a Boolean automorphism implies that ψ maps orthants into orthants, intersections of orthants into intersections of orthants, and so forth; and this ensures that the complementarity condition is not destroyed by the homeomorphisms. Linear homeomorphisms preserving the complementarity conditions include permutations of coordinates and dilations of the coordinate axes [52].

Corollary 5.7. Let $P \in \mathbb{R}^{n \times n}$ be a permutation matrix. Then, for any matrix $M \in \mathbb{R}^{n \times n}$, $M \sim N = P^\top M P$.

Corollary 5.8. Let $D \in \mathbb{R}^{n \times n}$ be a diagonal matrix with strictly positive entries. Then, for any matrix $M \in \mathbb{R}^{n \times n}$, $M \sim D^{-1} M D$ and $M \sim M D$.

Definition 5.9. Let $M \in \mathbb{R}^{n \times n}$ and $\beta \subseteq [1 \dots n]$ be such that $M_{\beta, \beta}$ is nonsingular. The principal pivotal transform (PPT) of M relative to β is the matrix $N \in \mathbb{R}^{n \times n}$

defined by

$$\begin{aligned} N_{\beta,\beta} &= (M_{\beta,\beta})^{-1} \\ N_{\beta,\beta^c} &= -(M_{\beta,\beta})^{-1} M_{\beta,\beta^c} \\ N_{\beta^c,\beta} &= M_{\beta^c,\beta} (M_{\beta,\beta})^{-1} \\ N_{\beta^c,\beta^c} &= M_{\beta^c,\beta^c} - M_{\beta^c,\beta} (M_{\beta,\beta})^{-1} M_{\beta,\beta^c} \end{aligned}$$

By convention, the PPT of M relative to \emptyset is M .

Corollary 5.10. *Let N be the PPT of M with respect to β . Then, $M \sim N$.*

6. STABILITY OF LCPS

Given an $LCP(M, q)$, we are now concerned with characterizing stability of the structure of the complementary cones with respect to changes in M and, therefore, the stability of its nonsmooth equilibrium bifurcations.

6.1. Definition and characterization of stability. Henceforth, we consider the usual topology on the vector space $\mathbb{R}^{n \times n}$.

Definition 6.1. A matrix $M \in \mathbb{R}^{n \times n}$ is *LCP-stable* if there exists a neighborhood U of M such that $M \sim N$ for all $N \in U$.

In order to characterize LCP stability, we take a deeper look into the geometric properties of the facets of the complementary cones. Recalling that $\mathcal{K}(M)$ denotes the union of all facets of the complementary cones of $M \in \mathbb{R}^{n \times n}$. Then, $\mathcal{K}(M) = \bigcup_{\alpha} \text{bdr } C_M(\alpha)$ [14, p. 511] and it breaks down \mathbb{R}^n into a finite number of connected regions.

Definition 6.2. Let $M \in \mathbb{R}^{n \times n}$. The *partition induced by M* , denoted as \mathcal{Q}_M , is the finite family of connected components of $\mathbb{R}^n \setminus \mathcal{K}(M)$.

A set $Q_M^i \in \mathcal{Q}_M$ is called a *cell* of \mathcal{Q}_M . The number of cells, r , in the partition induced by M depends on the number of solid complementary cones and how they intersect. The following properties are easy to verify,

- i) $Q_M^i \cap Q_M^j = \emptyset$ for $i \neq j$, $i, j \in [1 \dots r]$,
- ii) $\mathbb{R}^n = \text{cl} \bigcup_i Q_M^i$,
- iii) $\mathcal{K}(M) = \bigcup_i \text{bdr } Q_M^i$.

The cells of the partition are (non-necessarily convex) open cones delimited by the facets of the solid complementary cones of M . For P -matrices, the cells of the partition precisely agree with the interior of the complementary cones of M , see e.g., [59].

Lemma 6.3. *Let $M \in \mathbb{R}^{n \times n}$ be an R_0 matrix and let r be the number of sets in \mathcal{Q}_M . For every $\alpha \subseteq [1 \dots n]$ there exists $J \subset [1 \dots r]$ such that either*

$$\text{pos } C_M(\alpha) = \text{cl} \bigcup_{j \in J} Q_M^j$$

(when $\text{pos } C_M(\alpha)$ has non-empty interior) or

$$\text{pos } C_M(\alpha) \subset \bigcup_{j \in J} \text{bdr } Q_M^j$$

(when the interior of $\text{pos } C_M(\alpha)$ is empty).

Corollary 6.4. *$M \sim N$ if, and only if, there exists a bijection $\hat{\varphi}_* : \mathcal{Q}_M \rightarrow \mathcal{Q}_N$ induced by a homeomorphism $\hat{\varphi} : \mathbb{R}^n \rightarrow \mathbb{R}^n$.*

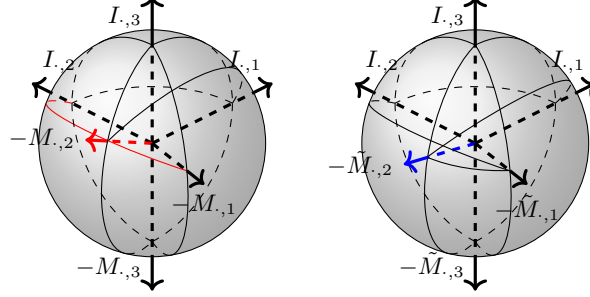

FIGURE 4. Projection onto the unit ball of complementary cones of the matrix M defined in (6.2)(left) and a perturbation \tilde{M} (right). The generator $-M_{.2} \in \text{pos}[-M_{.1}, I_{.2}]$ (in red). Thus, M is weakly degenerate whereas \tilde{M} is not.

Corollary 6.4 implies that, if $M \sim N$, then \mathcal{Q}_M and \mathcal{Q}_N must have the same number of cells. Consider a matrix $M \in \mathbb{R}^{n \times n}$ and a vector $-M_{.k}$ with $k \in [1 \dots n]$, and let $\mathcal{T}_k(M)$ be the collection of facets for which $-M_{.k}$ is not a generator,

$$\mathcal{T}_k(M) := \left\{ S \subset \mathbb{R}^n \mid S = \text{pos } C_M(\alpha)_{.,ic}, \alpha \subseteq [1 \dots n], k \notin \alpha, i \in [1 \dots n] \right\}.$$

Definition 6.5. Given $M \in \mathbb{R}^{n \times n}$, we say that M is *weakly degenerate* if it has a degenerate complementary cone or if

$$(6.1) \quad -M_{.k} \in \bigcup_{S \in \mathcal{T}_k(M)} S$$

for some $k \in [1 \dots n]$.

As an illustration, consider the matrix

$$(6.2) \quad M = \begin{bmatrix} \frac{1}{2} & \frac{5}{3} & 0 \\ 1 & 1 & 0 \\ -\frac{3}{10} & -1 & 1 \end{bmatrix}.$$

It is lengthy but straightforward to verify that there are no degenerate complementary cones, so M is non-degenerate. However, note that

$$\mathcal{T}_2(M) = \left\{ \text{pos}[I_{.2}, I_{.3}], \text{pos}[I_{.2}, -M_{.3}], \text{pos}[I_{.1}, I_{.3}], \text{pos}[-M_{.1}, I_{.3}], \right. \\ \left. \text{pos}[I_{.1}, -M_{.3}], \text{pos}[-M_{.1}, -M_{.3}], \text{pos}[I_{.1}, I_{.2}], \text{pos}[-M_{.1}, I_{.2}] \right\}$$

and that $-M_{.2} \in \text{pos}[-M_{.1}, I_{.2}]$, so M is a weakly degenerate matrix. Fig. 4 depicts the partitions that M and a perturbation \tilde{M} induce on the unit ball.

Lemma 6.6. *The set of weakly degenerate matrices is nowhere dense in $\mathbb{R}^{n \times n}$.*

Theorem 6.7. *A matrix $M \in \mathbb{R}^{n \times n}$ is LCP-stable if, and only if, M is not weakly degenerate.*

6.2. Explicit conditions for stability. Weak degeneracy is connected to the *positive* linear dependence property of particular subsets of generators of M , which is difficult to verify for large matrices [60]. On the other hand, efficient algorithms for verifying linear dependence are readily available. The fact that linear independence implies positive independence motivates the following.

Corollary 6.8. *If all minors of $M \in \mathbb{R}^{n \times n}$ are different from zero, then M is LCP-stable.*

Note that the condition of the corollary is sufficient but not necessary. For example, the identity I_n is stable, yet more than one of its minors are zero.

6.3. Stability margin. Let $\text{dist}(\cdot, S) : \mathbb{R}^n \rightarrow \mathbb{R}_+$ be the classical Euclidean distance from a point to a closed convex set $S \subset \mathbb{R}^n$, and let $\text{lin } A$ be the linear hull (span) of the columns of A .

Definition 6.9. The stability margin of M , $\text{sm} : \mathbb{R}^{n \times n} \rightarrow \mathbb{R}_+$, is given as,

$$(6.3) \quad \text{sm}(M) = \min \{d \mid d \in \mathcal{A} \cup \mathcal{B}\},$$

where

$$\begin{aligned} \mathcal{A} &= \left\{ \text{dist}(-\overline{M}_k; S) \mid S \in \mathcal{T}_k(M), k \in [1 \dots n] \right\}, \\ \mathcal{B} &= \left\{ \text{dist}(-\overline{M}_k; \text{lin } C_M(\alpha)_{\cdot, k^c}) \mid \alpha \subseteq [1 \dots n], k \in [1 \dots n] \right\}, \end{aligned}$$

and the column $\overline{M}_{\cdot, k} = \frac{1}{\|M_{\cdot, k}\|} M_{\cdot, k}$ is taken as a point in \mathbb{R}^n .

Note that \mathcal{A} contains zero elements whenever (6.1) holds, whereas \mathcal{B} contains zero elements whenever there are degenerate complementary cones. Thus, $\text{sm}(M) = 0$ if, and only if, M is not LCP-stable. It follows from the definition that, for any $M \in \mathbb{R}^{n \times n}$, $\text{sm}(M) \in [0, 1]$ and $\text{sm}(M) = 1$ if, and only if, $M = \text{Diag}\{a_1, \dots, a_n\}$, where $a_i > 0$ for $i \in [1 \dots n]$.

Example 6.10. Consider the matrix

$$(6.4) \quad M(\varepsilon) = \begin{bmatrix} -1 + \varepsilon & \varepsilon \\ \varepsilon & -1 + \varepsilon \end{bmatrix}.$$

Simple computations lead us to

$$\begin{aligned} \mathcal{A} &= \left\{ 1, \frac{|\varepsilon|}{\sqrt{(1-\varepsilon)^2 + \varepsilon^2}} \right\}, \\ \mathcal{B} &= \left\{ \frac{|1-\varepsilon|}{\sqrt{(1-\varepsilon)^2 + \varepsilon^2}}, \sin \left(\arccos \left(\frac{2\varepsilon(1-\varepsilon)}{(1-\varepsilon)^2 + \varepsilon^2} \right) \right) \right\}, \end{aligned}$$

where $\arccos : [-1, 1] \rightarrow [0, \pi]$. Note that $\text{sm}(M(\varepsilon)) = 0$ for $\varepsilon \in \{0, 1/2, 1\}$ and also $\lim_{\varepsilon \rightarrow \pm\infty} \text{sm}(M(\varepsilon)) = 0$ which indeed characterize all unstable cases for $M(\varepsilon)$. Fig. 5 below depicts the stability margin of (6.4) as a function of ε . The stability margin (6.3) can also be used for defining the *most stable matrices*. It can be seen in Fig. 5 that, for the matrix in (6.4), local maxima are attained at $\varepsilon \in \{-1.37, 0.37, 0.64, 2.37\}$. It is shown in Section 8 below that such points indeed coincide with the centers of mass of the stable regions presented in the classification diagram of Fig. 8.

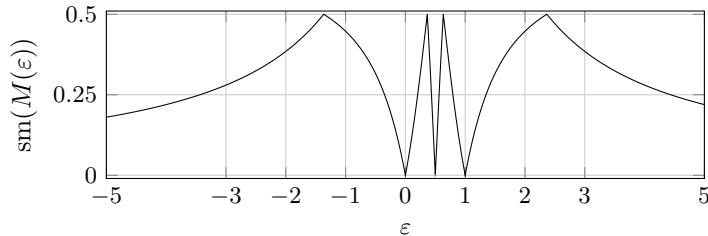

FIGURE 5. Stability margin of the matrix $M(\varepsilon)$ in (6.4) with local minima at $\varepsilon \in \{0, 1/2, 1\}$ (corresponding to unstable configurations), and local maxima at $\varepsilon \in \{-1.37, 0.37, 0.64, 2.37\}$.

7. APPLICATION TO NEGATIVE-RESISTANCE CIRCUITS

We will apply the results of the previous sections to the analysis of the circuit described in Section 3. The application is motivated by [47], where the authors present a heuristic procedure for constructing negative differential-resistance devices using only BJTs and resistors. The design strategy outlined in [47] ensures the satisfaction of an analytic condition that is necessary for having multiple solutions. Still, the question of whether a particular circuit actually exhibits negative resistance is settled by simulations. In this section, we employ the LCP formalism to derive necessary and sufficient conditions for having a negative resistance. Our objective is to find values of parameters that guarantee bistability of the network, resulting in the hysteretic behavior intrinsic of differential negative-resistance devices.

7.1. Circuit equilibria. Recall that the equilibria of (3.2) are characterized by the solutions to the LCP(M, q), where M and q are given in (4.9a) and (4.9b). The matrix inverse in (4.9a) complicates the computation of equilibria and the ensuing bifurcation analysis. Fortunately, the results of the previous sections ease the computational burden and open the way for an analytical treatment. Let $A, B, C \in \mathbb{R}^{4 \times 4}$ be nonsingular and defined by (3.5) and (3.6), and let $N := -CA^{-1}B$. By applying a pivotal transformation to N with $\beta = \{1, 2, 3, 4\}$ we obtain

$$\hat{M} := -B^{-1}AC^{-1}.$$

By Corollary 5.10, $N \sim \hat{M}$. Let M and q be defined by (4.9a), (4.9b), (3.5) and (3.6). If N is stable, $M = N + D \sim \hat{M}$ for $\|D\|$ small enough. Moreover, the solutions of the LCP(M, q) can be continuously mapped into the solutions of the LCP(\hat{M}, \hat{q}) with

$$\hat{q} := B^{-1}(AC^{-1}E_2s - E_1r),$$

where the expression follows from $\hat{q} = \varphi^{-1}(q)$ with φ as in (A.8). The interest of $M \sim \hat{M}$ is that we no longer require to compute M , which involves the inverse of A , defined by (3.5) and (3.6). Instead, we require to compute \hat{M} , which is easy, since B is block diagonal and $C = -I_4$. Indeed, \hat{M} is given explicitly by the submatrices

$$(7.1) \quad \begin{aligned} \hat{M}_{1,1} &= \begin{bmatrix} \frac{G_0^a + (1-\alpha_F)(G_2^a + G_2)}{\alpha_R G_0^a - (1-\alpha_R)(G_2^a + G_2)} & \frac{\alpha_F(G_1^a + G_1) - (1-\alpha_F)(G_2^a + G_2)}{G_1^a + G_1 + (1-\alpha_R)(G_2^a + G_2)} \\ \frac{\alpha_F G_1 - (1-\alpha_F)G_2}{\alpha_R} & \frac{\alpha_F}{\alpha_R} \end{bmatrix}, \\ \hat{M}_{1,2} &= \begin{bmatrix} -G_1 & \frac{\alpha_F G_1 - (1-\alpha_F)G_2}{\alpha_R} \\ -\frac{G_1}{\alpha_R} & \frac{G_1 + (1-\alpha_R)G_2}{\alpha_R} \end{bmatrix}, \quad \hat{M}_{2,1} = \begin{bmatrix} -G_2 & \frac{\alpha_F G_2 - (1-\alpha_F)G_1}{\alpha_R} \\ -\frac{G_2}{\alpha_R} & \frac{G_2 + (1-\alpha_R)G_1}{\alpha_R} \end{bmatrix}, \\ \hat{M}_{2,2} &= \begin{bmatrix} \frac{G_0^b + (1-\alpha_F)(G_2^b + G_1)}{\alpha_R} & \frac{\alpha_F(G_1^b + G_2) - (1-\alpha_F)(G_2^b + G_1)}{G_1^b + G_2 + (1-\alpha_R)(G_2^b + G_1)} \\ \frac{\alpha_F}{\alpha_R} & \frac{\alpha_F}{\alpha_R} \end{bmatrix}. \end{aligned}$$

7.2. Circuit bifurcations. We regard the potential difference $r = P_1 - P_0$ as a bifurcation or control parameter. We wish to find a set of resistor values for which, by changing r , the circuit transitions from global stability to bistability. The following corollary gives sufficient conditions for attaining this objective.

Corollary 7.1 ([52, Corollary 4.3]). *Let $\hat{M} \in \mathbb{R}^{n \times n}$ be an R_0 -matrix such that $\deg_{\hat{M}}(q) = 1$ for some $q \in \mathbb{R}^n$ and $f_{\hat{M}}$ has only one negative index. Then, there is $\alpha_0 \subseteq [1 \dots n]$ such that, for any $\hat{q} \in \text{int pos } C_{\hat{M}}(\alpha_0)$, the LCP(\hat{M}, \hat{q}) has exactly three solutions, whereas if $\hat{q} \in \mathbb{R}^n \setminus \text{pos } C_{\hat{M}}(\alpha_0)$, the solution is unique.*

With an explicit expression for \hat{M} , it is straightforward to check the conditions of Corollary 7.1.

$R_0^a = 100 \Omega$	$R_1^a = 2.2 \text{ k}\Omega$	$R_2^a = 100 \Omega$
$R_0^b = 100 \Omega$	$R_1^b = 100 \Omega$	$R_2^b = 10 \text{ k}\Omega$
$R_1 = 10 \Omega \quad R_2 = 0 \Omega - 1 \text{ k}\Omega$		

TABLE 1. Values of the parameters used for the circuit of Fig. 1.

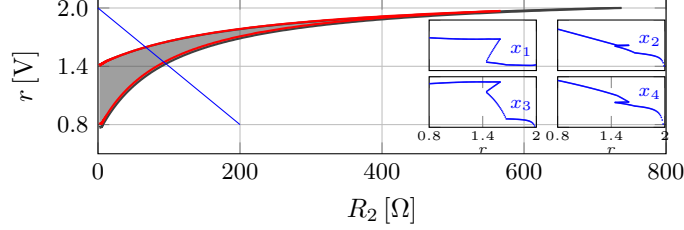

FIGURE 6. Two-parameter bifurcation diagram in the (R_2, r) -plane. The open set U_3 where $\text{LCP}(\hat{M}, \hat{q})$ has three solutions is highlighted in gray. There is only one solution in $U_1 = \text{int } \mathbb{R}^2 \setminus U_3$. The circuit bifurcates at $\text{bdr } U_3$. The set of parameters U_c for which the original $\text{LCP}(M, q)$ bifurcates is shown in red.

Proposition 7.2. *Let $\hat{M} \in \mathbb{R}^{4 \times 4}$ be given by (7.1) with all parameters finite and positive, and with $\alpha_F, \alpha_R \in (0, 1)$. Define*

$$(7.2) \quad \gamma := G_0^a G_0^b + (1 - \alpha_F) (G_0^a G_2^b + G_0^b G_2^a + (1 - \alpha_F) G_2^a G_2^b) \\ + (1 - \alpha_F) (G_0^a + (1 - \alpha_F) G_2^a) G_1 \\ - ((2\alpha_F - 1)G_1 - (1 - \alpha_F) (G_0^b + (1 - \alpha_F) G_2^b)) G_2 .$$

If:

- $\gamma > 0$, then the $\text{LCP}(\hat{M}, \hat{q})$ has a unique solution, regardless of \hat{q} .
- $\gamma < 0$, then the $\text{LCP}(\hat{M}, \hat{q})$ may have a unique solution or three solutions, depending on the specific value of \hat{q} .
- $\gamma = 0$, then \hat{M} is LCP-unstable.

For real transistors we have $\alpha_F \in [0.8, 0.99]$ and $\alpha_R \approx 0.5$ [48]. It thus follows that we can make $\gamma < 0$ by setting G_1 and G_2 large enough, whenever the remaining conductances stay finite. Regarding the condition $\hat{q} \in \text{int pos } C_{\hat{M}}(\hat{\alpha}_0)$ in Corollary 7.1, we will verify it numerically once the resistor parameters have been chosen. For concreteness, we consider all capacitors with the same value of $100 \mu\text{F}$, $\alpha_F = 0.99$, $\alpha_R = 0.5$, and $s = 0.7 \text{ V}$. The values of the resistances R_k^j , $k \in \{0, 1, 2\}$, $j \in \{a, b\}$ are selected arbitrarily, whereas G_1 is chosen in such a way that the factor associated with G_2 in (7.2) is strictly negative. The chosen values are shown in Table 1.

With the setting described in the previous paragraph, we can use G_2 to set the sign of γ . Fig. 6 shows the (R_2, r) -bifurcation diagrams of $\text{LCP}(\hat{M}, \hat{q})$ and $\text{LCP}(M, q)$.

7.3. Asymptotic properties of the circuit. It only rest to show that, with the chosen parameters, the network shows bistability. To that end, we use the recent approach of dominant systems developed in [61, 62]. Specifically, with our selection of parameters, the system (3.2a)-(3.2b) is strictly 1-passive from the “input” z to

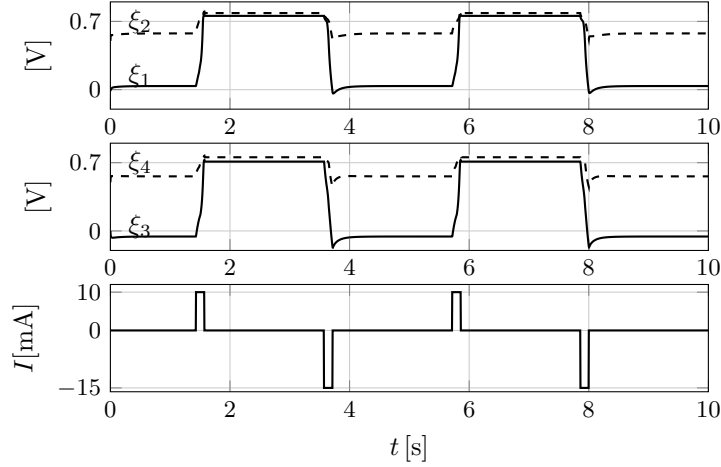

FIGURE 7. Time trajectories of states ξ_1, ξ_2 (top) and ξ_3, ξ_4 (middle) of the circuit of Fig. 1. The extra current input I (bottom) confirms the bistable nature of the circuit.

the “output” w . That is, it satisfies the λ -parameterized linear matrix inequality

$$\begin{bmatrix} A^\top P + PA + 2\lambda P + \varepsilon I & PB_1 - C^\top \\ B_1^\top P - C & -D - D^\top \end{bmatrix} \leq 0$$

for values of $\lambda \in [105, 135]$ and

$$P = \begin{bmatrix} -1.87 & -5.96 & -2.42 & 3.65 \\ -5.96 & -5.66 & -5.90 & -0.18 \\ -2.42 & -5.90 & -0.86 & 4.42 \\ 3.65 & -0.18 & 4.42 & 4.67 \end{bmatrix} \times 10^{-3},$$

which has inertia $(1, 0, 3)$. Now, since the complementarity condition (3.2c) is incrementally passive (0-passive in the language of [61]), we conclude that the closed-loop (3.2a)-(3.2c) is 1-passive with rate $\lambda > 0$ and therefore 1-dominant. Hence, the asymptotic behavior of the network is topologically equivalent to the asymptotic behavior of a 1-dimensional system. Further, standard computations show that the trajectories are bounded and there is one unstable equilibrium, leading us to the desired conclusion. Fig. 7 shows the time evolution of the states of the network for the choice of parameters described above when an additional current source is connected between the terminals $P_1 - P_0$, confirming the desired bistable behavior.

8. CLASSIFICATION OF TWO-DIMENSIONAL LCPS AND THEIR STABILITY MARGINS

In this section, we apply the results on LCP equivalence and stability in order to classify all possible cone configurations of 2-dimensional LCPS and, therefore, all possible bifurcations of an associated LCS. Our incentive for studying such a low-dimensional problem in full detail comes from the fact that, in some cases, the singularities of an LCP can be assessed by studying a lower-dimensional one.

Example 8.1. Let

$$M = \begin{bmatrix} M_{11} & M_{12} \\ 0 & M_{22} \end{bmatrix} \quad \text{and} \quad q = \begin{bmatrix} q_1 \\ q_2 \end{bmatrix},$$

and consider a triangular LCP(M, q). Suppose that M_{22} is a P -matrix. Then, x_2 is uniquely given by

$$x_2 = f_{M_{22}}^{-1}(q_2) .$$

Moreover, since M_{22} is a P -matrix, $f_{M_{22}}$ is regular. The problem can be then rewritten as

$$f_{M_{11}}(x_1) = \bar{q}_1 , \quad \bar{q}_1 = M_{12}[-f_{M_{22}}^{-1}(q_2)]^+ + q_1 ,$$

from where we see that the nonsmooth singularities of the LCP(M, q) are determined by the nonsmooth singularities of the lower-dimensional LCP(M_{11}, \bar{q}_1).

Using the characterization of stable LCPs provided by Theorem 6.7, we start by enumerating all the unstable matrices. Such enumeration is performed by writing down all the conditions leading to weakly degenerate matrices. For $n = 2$, such classification is relatively easy since, in $\mathbb{R}^{2 \times 2}$, weakly degenerate matrices either satisfy $-M_{.,k} \in \text{pos } I_{.,k}$, for $k \in [1 \dots 2]$, or they have degenerate complementary cones. Moreover, it follows from Corollary 5.8 that any matrix $N \in \mathbb{R}^{2 \times 2}$ is LCP-equivalent to the matrix

$$(8.1) \quad M(\theta_1, \theta_2) = \begin{bmatrix} r_1 \cos(\theta_1 + \pi) & r_2 \cos(\theta_2 + \frac{3\pi}{2}) \\ r_1 \sin(\theta_1 + \pi) & r_2 \sin(\theta_2 + \frac{3\pi}{2}) \end{bmatrix} ,$$

where $r_1, r_2 \in \{0, 1\}$ and $(\theta_1, \theta_2) \in [0, 2\pi) \times [0, 2\pi)$ are angles measured in counterclockwise direction with respect to the rays $\text{pos } I_{.,1}$ and $\text{pos } I_{.,2}$, respectively. In what follows, we use the representation (8.1) for enumerating all 2×2 unstable matrices. First we consider the class of strongly degenerate matrices, for which at least one column is zero. It is characterized by the conditions

$$(8.2) \quad \begin{aligned} r_1 r_2 &= 0 \\ (\theta_1, \theta_2) &\in [0, 2\pi) \times [0, 2\pi) . \end{aligned}$$

The second class of unstable matrices encompasses the strongly degenerate matrices for which at least one complementary cone is a subspace of \mathbb{R}^n . This class is characterized by the conditions

$$(8.3) \quad \begin{aligned} r_1 = r_2 &= 1 , \\ (\theta_1, \theta_2) &\in \Theta^+ \cup \left(\left\{ \frac{3\pi}{2} \right\} \times [0, 2\pi] \right) \\ &\cup \left([0, 2\pi) \times \left\{ \frac{\pi}{2} \right\} \right) , \end{aligned}$$

where

$$\Theta^+ = \left\{ (\theta_1, \theta_2) \mid \theta_1 \in [0, 2\pi), \theta_2 = \left(\theta_1 + \frac{\pi}{2} \right) \bmod 2\pi \right\} .$$

Certainly, matrices satisfying either (8.2) or (8.3), lie outside of the R_0 -class. Finally, we consider the class of unstable R_0 -matrices embracing the remaining degenerate and weakly degenerate matrices. This class is characterized by the conditions

$$(8.4) \quad \begin{aligned} r_1 = r_2 &= 1 , \\ (\theta_1, \theta_2) &\in \Theta^- \cup \left(\left\{ \frac{\pi}{2} \right\} \times [0, 2\pi) \right) \\ &\cup \left([0, 2\pi) \times \left\{ \frac{3\pi}{2} \right\} \right) , \end{aligned}$$

where

$$\Theta^- := \left\{ (\theta_1, \theta_2) \mid \theta_1 \in [0, 2\pi), \theta_2 = \left(\theta_1 - \frac{\pi}{2} \right) \bmod 2\pi \right\} .$$

The list of unstable normal forms complements the stable normal forms enumerated in [37]. However, the list (8.2)-(8.4) is more fundamental, in the sense that representatives of all stable classes can be obtained as perturbations of conditions (8.2)-(8.4). Figure 8 illustrates the partition of the space of 2×2 matrices at

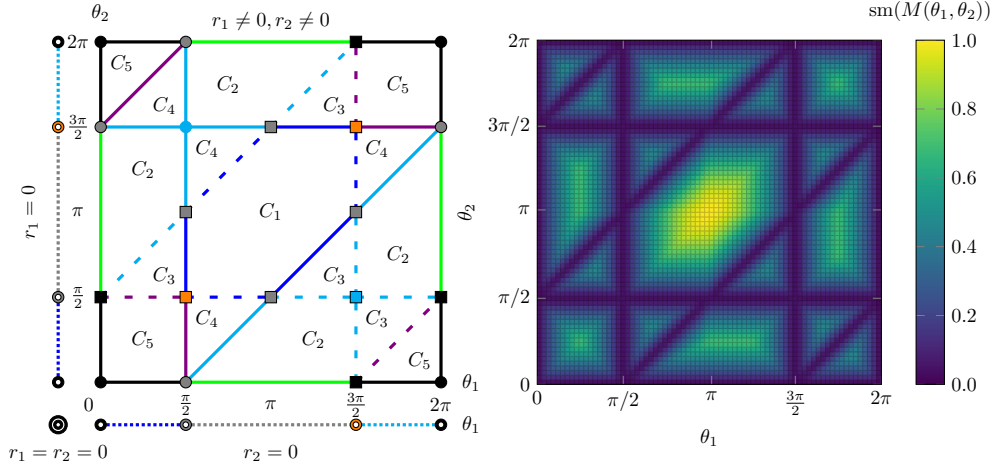

FIGURE 8. (Left) Classification of 2×2 matrices (8.1). Line segments and points with the same color, style and shape are LCP-equivalent. In the central square, regions of stable matrices (C_1 – C_5) are delimited by the unstable matrices satisfying (8.2)–(8.4). (Right) Stability margin (6.3) of 2×2 matrices in the space of parameters (θ_1, θ_2) for the case $r_1 \neq 0$ and $r_2 \neq 0$. Note that local maxima are closer to the centers of mass of the stable regions.

different levels. Line segments and points with the same color, style and shape are LCP-equivalent. Unstable matrices satisfying (8.2), (8.3), and (8.4) are depicted using dotted, dashed, and solid lines, respectively. The double annular mark at the bottom left corner represents the zero matrix ($r_1 = r_2 = 0$). Perturbations of this matrix will lead to any of the other three cases: a point on the left vertical line characterizing the cases where $r_1 = 0$, a point on the bottom horizontal line characterizing the cases where $r_2 = 0$, or a point on the central square for which $r_1 \neq 0$ and $r_2 \neq 0$. Connected white regions on the central square correspond to stable matrices. It turns out that there are five different classes of stable matrices² in $\mathbb{R}^{2 \times 2}$. The complementary cones of representative members of each class are shown in Fig. 9. From Example 6.10 we concluded that the stability margin of the matrix in (6.4) reaches its maximum value at

$$\varepsilon \in \{-1.37, 0.37, 0.64, 2.37\}.$$

In terms of the normal form (8.1) those points correspond to the cases,

$$(\theta_1, \theta_2) \in \left\{ \left(\frac{\pi}{6}, \frac{11\pi}{6} \right), \left(\frac{11\pi}{6}, \frac{\pi}{6} \right), \left(\frac{5\pi}{3}, \frac{\pi}{3} \right), \left(\frac{4\pi}{3}, \frac{2\pi}{3} \right) \right\}.$$

Simple computations show that local maxima are attained at the center of mass of regions delimiting stable classes (see right-hand side of Fig. 8). It is verified that the stability margin indeed characterizes the stable and unstable configurations shown in the left-hand side of Fig. 8, thus providing a computational tool that can be used for assessing the LCP-stability of larger matrices. We conclude this section by pointing out that the classification diagrams in Figs. 8-9 allow us to derive some properties and relations concerning well-known families of matrices associated to LCPS [63]. For instance, the union of all LCP-stable matrices together with their

²In [37], the classes C_2 and C_4 were mistakenly taken to be the same one.

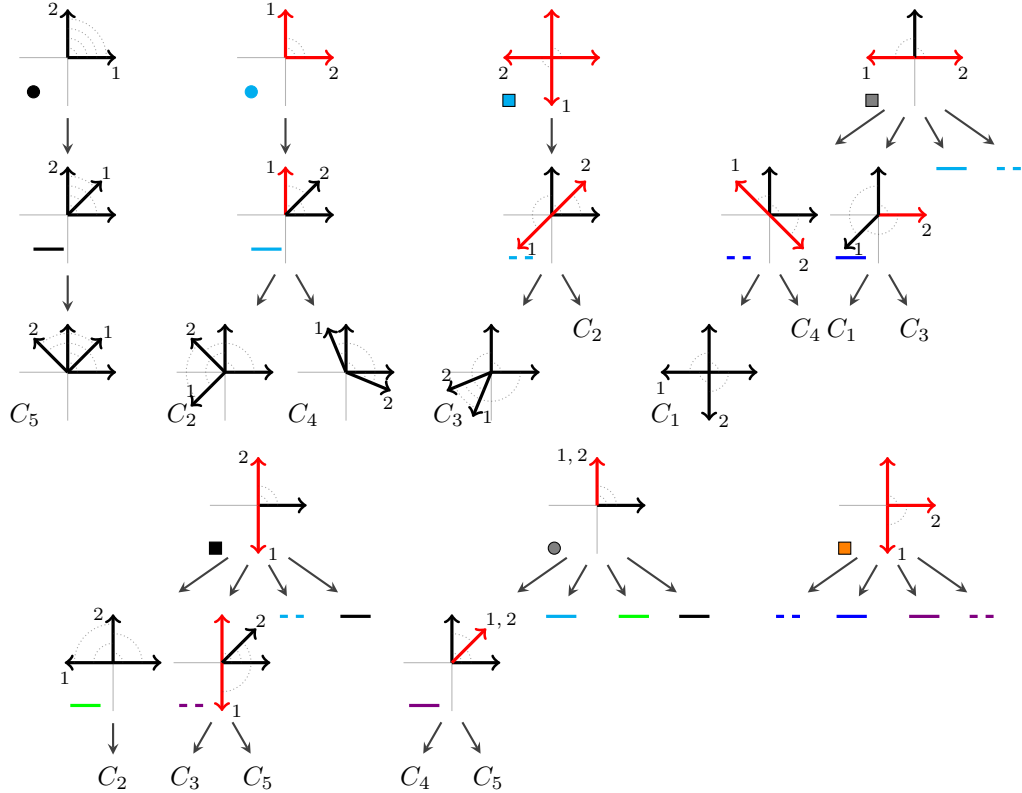

FIGURE 9. Complementary cone configurations of representative members of the classes depicted in the central square in Fig. 8. Highly-degenerate configurations (circles and squares) break down into less-degenerate configurations (solid and dashed lines), which in turn break down into the stable configurations ($C_1 - C_5$). Red rays denote degenerate cones and the labels 1 and 2 on the rays stand for the rays $\text{pos}(-M_{.,1})$ and $\text{pos}(-M_{.,2})$, respectively.

solid-line boundaries match the set of 2×2 R_0 -matrices, which is open [50]. The class C_1 agrees with the set of P -matrices for which there is a unique solution to $\text{LCP}(M, q)$ for any $q \in \mathbb{R}^2$, whereas the closure of C_1 is the set of P_0 -matrices. The set of Q -matrices, for which $\text{LCP}(M, q)$ admits at least one solution for any $q \in \mathbb{R}^2$, is the union of the stable classes C_1 and C_3 , together with their shared boundaries (blue solid lines in Fig. 8) which is also an open set. It is worth to remark that the set of Q matrices is not connected, since $M(\theta_1, \frac{\pi}{2})$ is not a Q -matrix for any $\theta_1 \in [0, 2\pi)$. A matrix M is copositive if $x^\top Mx \geq 0$ for all $x \in \mathbb{R}_+^n$, it is strictly copositive if $x^\top Mx > 0$ for all $x \in \mathbb{R}_+^n \setminus \{0\}$. Strictly copositive matrices are important from an algorithmic viewpoint, as for such matrices the convergence of Lemke's algorithm towards a solution is guaranteed [64].

Proposition 8.2. *Any 2×2 Q -matrix is LCP-equivalent to a strictly copositive matrix.*

The fact that strictly copositive matrices are Q -matrices holds for the general case in \mathbb{R}^n [14, Theorem 3.8.5]. However, in general, the converse does not hold.

That is, not all Q -matrices are strictly copositive. Thus, the relevance of Proposition 8.2 relies on the fact that, in the planar case, there is a bijection between the solutions of $\text{LCP}(M_1, q_1)$, with M_1 a Q -matrix, and the solutions of $\text{LCP}(M_2, q_2)$ for some M_2 strictly copositive. The LCP-equivalence between Q and strictly copositive matrices rests an open question in the general case.

9. CONCLUSIONS

Motivated by developing a general non-smooth bifurcation theory, we related LCS equilibrium bifurcations with LCP singularities and leveraged the rich LCP geometry to derive a notion of equivalence between LCPs that is akin the classical notion of topological equivalence at the foundations of smooth bifurcation theory. Our notion of equivalence allows us to characterize both stable and unstable (from the viewpoint of bifurcations) of LCPs and therefore to determine under which condition a model is fragile (i.e., prone to lose its bifurcation behavior) or robust (i.e., prone to preserve its bifurcation behavior) under parameter perturbations. We illustrated our theory on a fairly general prototypical negative resistance circuit using resistors and bipolar transistors. For this circuit, our methods provides constructive conditions to modulate the circuit behavior through parameter tuning. We also applied our notion of equivalence to the full characterization of stable and unstable LCPs in two dimensions and compute their stability margins. Future work will consider the extension of our notion of equivalence to allow complementarity problems of different dimensions, as well as extensions to other types of complementarity problems and general (i.e., not purely equilibrium) bifurcations on linear complementarity systems.

APPENDIX A. PROOFS

Of Lemma 4.7. It follows from (4.1) that, for $x \in \text{pos } C_I(\alpha)$, we have $x_j \leq 0$ if $j \in \alpha$, whereas $x_j \geq 0$ if $j \notin \alpha$. Then, equation (4.2) can be written as

$$\begin{aligned} f_M(x) &= \sum_{j=1}^n C_{-M}(\alpha)_{.,j} x_j = \sum_{j \notin \alpha} I_{.,j} x_j + \sum_{j \in \alpha} M_{.,j} x_j \\ &= \sum_{j=1}^n I_{.,j} [x_j]^+ - \sum_{j=1}^n M_{.,j} [-x_j]^+, \end{aligned}$$

from which (4.5) follows directly. \square

Of Theorem 4.10. It follows from Lemma 4.7 that $f_D(x) = [x]^+ - D[-x]^+$ and $f_M(x) = [x]^+ - (D - CA^{-1}B)[-x]^+$, leading to

$$(A.1) \quad f_M(x) = f_D(x) + CA^{-1}B[-x]^+.$$

Suppose that $F(\xi^*, r, s) = 0$ and set $x^* = X(\xi^*, s)$. By (4.10), we have

$$(A.2) \quad f_D(x^*) = C\xi^* + E_2s$$

which, when substituted in (A.1), yields

$$(A.3) \quad f_M(x^*) = C\xi^* + E_2s + CA^{-1}B[-x^*]^+.$$

Since A is nonsingular, we can use (4.8) and rewrite $F(\xi^*, r, s) = 0$ as

$$(A.4) \quad \xi^* = -A^{-1}(B[-x^*]^+ + E_1r).$$

Substitution of (A.4) into (A.3) leads us to $f_M(x^*) = \bar{q}(r, s)$.

Conversely, suppose that $f_M(x^*) = \bar{q}(r, s)$. Equation (A.1) implies that

$$(A.5) \quad f_D(x^*) + CA^{-1}B[-x^*]^+ = E_2s - CA^{-1}E_1r.$$

Set $\xi^* = \Xi(x^*, r)$. It follows from the definition of Ξ that

$$C\xi^* + E_2s = -CA^{-1}(B[-x^*]^+ + E_1r) + E_2s$$

which, according to (A.5), gives (A.2). Finally, by combining (A.2) and (4.11) we obtain the equilibrium condition

$$\xi^* = -A^{-1}(B[-f_D^{-1}(C\xi^* + E_2s)]^+ + E_1r) .$$

□

Of Corollary 4.11. By Theorem 4.10,

$$\{x \mid f_M(x) = \bar{q}(r, s)\} = \{X(\xi, s) \mid F(\xi, r, s) = 0\}$$

and, similarly,

$$\{\xi \mid F(\xi, r, s) = 0\} = \{\Xi(x, s) \mid f_M(x) = \bar{q}(r, s)\} .$$

Then, the map $(r, s) \mapsto \{x \mid f_M(x) = \bar{q}(r, s)\}$ can be expressed as the composition of the map $(r, s) \mapsto \{\xi \mid F(\xi, r, s) = 0\}$ and the Lipschitz map $X(\cdot, s)$, and, vice versa, the map $(r, s) \mapsto \{\xi \mid F(\xi, r, s) = 0\}$ can be expressed as the composition of the map $(r, s) \mapsto \{x \mid f_M(x) = \bar{q}(r, s)\}$ and the Lipschitz map $\Xi(\cdot, s)$. Recalling that the composition of Lipschitz-continuous maps is Lipschitz-continuous, the map $(r, s) \mapsto \{\xi \mid F(\xi, r, s) = 0\}$ is single-valued and Lipschitz-continuous in a neighborhood of (ξ_0, r_0, s_0) if, and only if, the map $(r, s) \mapsto \{x \mid f_M(x) = \bar{q}(r, s)\}$ is single-valued and Lipschitz-continuous in a neighborhood $(X(\xi_0, s_0), r_0, s_0)$. □

Of Theorem 5.5. Since ψ_* is an automorphism on \mathcal{F}_I , for any $\alpha \subseteq [1 \dots n]$, there exists a unique $\beta \subseteq [1 \dots n]$ such that $\text{pos } C_I(\alpha) = \psi^{-1}(\text{pos } C_I(\beta))$. It then follows from (4.2) and (5.2) that $\varphi^{-1}(C_{-M}(\alpha)x) = C_{-N}(\beta)\psi(x)$ for $x \in \text{pos } C_I(\alpha)$. By (4.3) we finally have

$$\varphi^{-1}(\text{pos } C_M(\alpha)) = \text{pos } C_N(\beta) ,$$

which shows that φ induces a bijection from \mathcal{G}_M to \mathcal{G}_N . □

Of Theorem 5.6. The bijectivity of $\varphi_* : \mathcal{F}_M \rightarrow \mathcal{F}_N$ implies that, for each $\alpha \subseteq [1 \dots n]$, there exists a unique $\beta \subseteq [1 \dots n]$ such that

$$(A.6) \quad \varphi_*(\text{pos } C_M(\alpha)) = \text{pos } C_N(\beta) .$$

We will explicitly construct a piecewise linear map $\psi : \mathbb{R}^n \rightarrow \mathbb{R}^n$ and verify (5.2). By (4.3) and (A.6), for each $x \in \text{pos } C_I(\alpha)$ there exists an $x' \in \text{pos } C_I(\beta)$ such that

$$(A.7) \quad \varphi^{-1}(C_{-M}(\alpha)x) = C_{-N}(\beta)x' .$$

Moreover, x' is unique by the invertibility of C_{-N} (which follows by the non-degeneracy of N). We define $\psi : x \mapsto x'$ with x' so constructed, so that

$$\varphi^{-1}(C_{-M}(\alpha)x) = C_{-N}(\beta)\psi(x)$$

for $x \in \text{pos } C_I(\alpha)$. This is simply an explicit rewriting of (5.2). Since φ^{-1} is bijective, we can reverse the argument in order to find ψ^{-1} . The continuity of ψ and ψ^{-1} are simple consequences of the continuity of φ , φ^{-1} , f_M and f_N . Finally, note that ψ induces a permutation on \mathcal{G}_I , and hence an automorphism on \mathcal{F}_I . □

Of Corollary 5.7. Let $\varphi(q') = Pq'$ and $\psi(x) = P^\top x$, and note that ψ induces a Boolean automorphism on \mathcal{F}_I . Also, note that $P[x]^+ = [Px]^+$. The proof then follows from (4.5),

$$f_M(x) = [x]^+ - M[-x]^+ = P([P^\top x]^+ - N[-P^\top x]^+) = \varphi \circ f_N \circ \psi(x) .$$

□

Of Corollary 5.8. For the first equivalence, let $\varphi(q') = Dq'$ and $\psi(x) = D^{-1}x$, and note that ψ is a Boolean automorphism on \mathcal{F}_I . We also have $D[x]^+ = [Dx]^+$. As in the previous corollary, $f_M(x) = \varphi \circ f_N \circ \psi(x)$. For the second equivalence, let φ be the identity map, $\varphi(q) = q$, and $\psi(x) = C_{-D}(\alpha)x$ for $x \in \text{pos } C_I(\alpha)$. Both φ and ψ are continuous and invertible. Hence, $f_{MD}(x) = C_{-MD}(\alpha)x = C_{-M}(\alpha)C_{-D}(\alpha)x = \varphi \circ f_M \circ \psi(x)$, for some $\alpha \in [1 \dots n]$ and the conclusion follows. \square

Of Corollary 5.10. If $\beta = \emptyset$ the result holds trivially, so we suppose that $\beta \neq \emptyset$. Let $P \in \mathbb{R}^{n \times n}$ be the permutation matrix such that $P^\top \xi = [\xi_\beta^\top, \xi_{\beta^c}^\top]^\top$ and define $\psi(x) = C_I(\beta)x$. It follows from (4.5) that

$$\begin{aligned} & P^\top (f_M \circ \psi)(x) \\ &= [P^\top C_I(\beta)x]^+ - P^\top M P [-P^\top C_I(\beta)x]^+ \\ &= \begin{bmatrix} -x_\beta \\ x_{\beta^c} \end{bmatrix}^+ - \begin{bmatrix} M_{\beta,\beta} & M_{\beta,\beta^c} \\ M_{\beta^c,\beta} & M_{\beta^c,\beta^c} \end{bmatrix} \begin{bmatrix} x_\beta \\ -x_{\beta^c} \end{bmatrix}^+ \\ &= \begin{bmatrix} -M_{\beta,\beta} & 0 \\ -M_{\beta^c,\beta} & I_{|\beta^c|} \end{bmatrix} \begin{bmatrix} x_\beta \\ x_{\beta^c} \end{bmatrix}^+ - \begin{bmatrix} -I_{|\beta|} & M_{\beta,\beta^c} \\ 0 & M_{\beta^c,\beta^c} \end{bmatrix} \begin{bmatrix} -x_\beta \\ -x_{\beta^c} \end{bmatrix}^+ \\ &= \begin{bmatrix} -M_{\beta,\beta} & 0 \\ -M_{\beta^c,\beta} & I_{|\beta^c|} \end{bmatrix} ([P^\top x]^+ - P^\top N P [-P^\top x]^+) \\ &= \begin{bmatrix} -M_{\beta,\beta} & 0 \\ -M_{\beta^c,\beta} & I_{|\beta^c|} \end{bmatrix} P^\top f_N(x) \end{aligned}$$

Hence, $f_N = \varphi \circ f_M \circ \psi$ with

$$(A.8) \quad \varphi(q') = P \begin{bmatrix} -M_{\beta,\beta}^{-1} & 0 \\ -M_{\beta^c,\beta} M_{\beta,\beta}^{-1} & I_{|\beta^c|} \end{bmatrix} P^\top q'.$$

Therefore, $N \sim M$. \square

Of Lemma 6.3. Assume first that $\text{pos } C_M(\alpha)$ is a solid cone. Then, there exists $j_1 \in [1 \dots r]$ such that $Q_M^{j_1} \subset \text{pos } C_M(\alpha)$. Let $\mu(E)$ be the Lebesgue measure of $E \subset \mathbb{R}^n$. If

$$\mu(\text{pos } C_M(\alpha) \setminus Q_M^{j_1}) = 0,$$

then $\text{pos } C_M(\alpha) = \text{cl } Q_M^{j_1}$, as desired. If

$$\mu(\text{pos } C_M(\alpha) \setminus Q_M^{j_1}) > 0,$$

then there exists $j_2 \in [1 \dots r]$, $j_2 \neq j_1$, such that $Q_M^{j_2} \subset (\text{pos } C_M(\alpha) \setminus Q_M^{j_1})$. As before, if

$$\mu(\text{pos } C_M(\alpha) \setminus (Q_M^{j_1} \cup Q_M^{j_2})) = 0,$$

then $\text{pos } C_M(\alpha) = \text{cl } (Q_M^{j_1} \cup Q_M^{j_2})$, as desired. Since $\text{pos } C_M(\alpha)$ is strictly pointed and \mathcal{Q}_M is finite and the union is dense in \mathbb{R}^n (property ii) above), the procedure just introduced stops after a finite number of iterations with $J \subset [1 \dots r]$ and the result follows. Suppose now that $\text{pos } C_M(\alpha)$ is degenerate. Then, $\text{pos } C_M(\alpha) \subset \bigcup_{j \in J} \text{bdr } Q_M^j \subset \mathcal{K}(M)$ for some $J \subset [1 \dots r]$. \square

Of Corollary 6.4. Suppose that $M \sim N$. Then, there is a homeomorphism $\varphi : \mathbb{R}^n \rightarrow \mathbb{R}^n$ such that

$$\varphi^{-1}(\text{bdr } \text{pos } C_M(\alpha)) = \text{bdr } \text{pos } C_N(\beta(\alpha))$$

and

$$\varphi^{-1}(\text{int } C_M(\alpha)) = \text{int } C_N(\beta(\alpha)),$$

for all $\alpha \subset [1 \dots n]$ and some

$$\beta : \mathcal{P}([1 \dots n]) \rightarrow \mathcal{P}([1 \dots n]) .$$

Thus, φ^{-1} maps connected regions of $\mathbb{R}^n \setminus \mathcal{K}(M)$ into connected regions of $\mathbb{R}^n \setminus \mathcal{K}(N)$, thereby inducing a bijection between \mathcal{Q}_M and \mathcal{Q}_N . On the other hand, if $\hat{\varphi}$ induces a bijection $\hat{\varphi}_*$, it follows from Lemma 6.3 and the continuity of $\hat{\varphi}$, that $\hat{\varphi}$ also induces an isomorphism between \mathcal{F}_M and \mathcal{F}_N . \square

Of Lemma 6.6. By definition, a weakly degenerate matrix M belongs to the union of the set of singular matrices and the set

(A.9)

$$H := \{M \in \mathbb{R}^{n \times n} \mid \text{there exist } k \in [1 \dots n] \text{ and } S \in \mathcal{T}_k(M) \text{ such that } -M_{\cdot,k} \in S\} .$$

It is well known that the set of singular matrices is nowhere dense in $\mathbb{R}^{n \times n}$. Indeed, the same is true for the set H . Consider $\hat{S} \in \mathbb{R}^{n \times (n-1)}$ such that $\text{pos } \hat{S} \in \mathcal{T}_k(M)$. It follows that $\det([\hat{S}, -M_{\cdot,k}]) = 0$ and H is nowhere dense. To conclude, recall that the finite union of nowhere dense sets is again nowhere dense. \square

Of Theorem 6.7. Let us assume first that some complementary cones of M are degenerate. Since the set of matrices with non-zero principal minors is dense in the set of square matrices, there exists a matrix N , arbitrarily close to M , without degenerate complementary cones. A bijection $\varphi_* : \mathcal{G}_M \rightarrow \mathcal{G}_N$ necessarily maps a complementary cone with empty interior onto a complementary cone with non-empty interior. Clearly, $\varphi : \mathbb{R}^n \rightarrow \mathbb{R}^n$ cannot be invertible and hence cannot be a homeomorphism. Therefore, M is not LCP-stable. Assume now that $M \in H$. Then, there is $J \subset [1 \dots n]$ such that, for each $k \in J$, there exists a matrix $\hat{S} \in \mathbb{R}^{n \times (n-1)}$ satisfying

$$\text{pos}[\hat{S}, -M_{\cdot,k}] = \text{pos } \hat{S} = S \in \mathcal{T}_k(M) .$$

From Lemma 6.6, there exists $N \in \mathbb{R}^{n \times n}$ arbitrarily close to M such that N is not weakly degenerate. In other words, $\det[\hat{S}, -N_{\cdot,k}] \neq 0$, so that $\text{pos}[\hat{S}, -N_{\cdot,k}]$ has non-empty interior. Once again, there is no homeomorphism mapping $\text{pos}[\hat{S}, -M_{\cdot,k}]$ into $\text{pos}[\hat{S}, -N_{\cdot,k}]$. It follows that M is not LCP-stable. For sufficiency, let us assume that M is not weakly degenerate. There exists a neighborhood U of M such that, for every $N \in U$, the partitions \mathcal{Q}_M and \mathcal{Q}_N have the same number of cells. Indeed, each cell in \mathcal{Q}_M is a solid cone by construction and, because there are no degenerate cones nor $k \in [1 \dots n]$ such that $-M_{\cdot,k} \in S$ for some $S \in \mathcal{T}_k(M)$, the cells remain solid for sufficiently small perturbations. Thus, neither new cells appear nor existing cells disappear in U . Now, there exist refinements $\hat{\mathcal{Q}}_M$ and $\hat{\mathcal{Q}}_N$ of the partitions induced by M and $N \in U$, respectively, such that each cell is a convex cone with exactly n generators and the number of cells is the same for both partitions. There is thus a one-to-one map $\eta : \hat{\mathcal{Q}}_M \rightarrow \hat{\mathcal{Q}}_N$ such that neighbors are preserved, that is, any two cells in $\hat{\mathcal{Q}}_M$ sharing a p -dimensional face are mapped under η into cells in $\hat{\mathcal{Q}}_N$ sharing also a p -dimensional face. Let $\hat{Q}_k(M)$ and $\hat{Q}_k(N) = \eta(\hat{Q}_k(M))$ be, respectively, matrices that generate the cells of the new partitions $\hat{\mathcal{Q}}_M$ and $\hat{\mathcal{Q}}_N$, where $k \in [1 \dots \hat{r}]$ and $\hat{r} = |\hat{\mathcal{Q}}_M| = |\hat{\mathcal{Q}}_N|$. Define $\hat{\varphi} : \mathbb{R}^n \rightarrow \mathbb{R}^n$ as the piecewise linear function

$$(A.10) \quad \hat{\varphi}(q') = \hat{Q}_k(M)\hat{Q}_k(N)^{-1}q' \text{ for } q' \in \text{pos } \hat{Q}_k(N) .$$

Notice that $\hat{\varphi}$ is continuous by construction, since neighbor cells share $n - 1$ generators. That is,

$$\lim_{\substack{q'_i \rightarrow q \\ q'_i \in \text{pos } \hat{Q}_k(N)}} \hat{\varphi}(q'_i) = \lim_{\substack{q'_i \rightarrow q \\ q'_i \in \text{pos } \hat{Q}_s(N)}} \hat{\varphi}(q'_i)$$

for any $q' \in \text{pos } \hat{Q}_k(N) \cap \text{pos } \hat{Q}_s(N)$. Finally, by similar arguments, $\hat{\varphi}^{-1}$ exists and is also continuous. Furthermore, $\hat{\varphi}_* : \mathcal{Q}_M \rightarrow \mathcal{Q}_N$ is a bijection. Therefore, M and N are LCP-equivalent and, since N is arbitrary, we conclude that M is LCP-stable. \square

Of Corollary 6.8. Note that, if every minor of M is non-zero, then M cannot be weakly degenerate. Indeed, using Laplace's expansion we can see that, for any non-empty sets $\alpha, \beta \subseteq [1 \dots n]$ such that $|\alpha| = |\beta|$,

$$(A.11) \quad |\det M_{\alpha,\beta}| = |\det[I_{\cdot,\alpha^c}, M_{\cdot,\beta}]|.$$

Thus, our assumption on the minors of M implies that any subset of n vectors of

$$\{I_{\cdot,1}, \dots, I_{\cdot,n}, -M_{\cdot,1}, \dots, -M_{\cdot,n}\}$$

is linearly independent. Consequently, M does not have degenerate cones and $-M_{\cdot,k}$ is not in the linear span of S for all $S \in \mathcal{T}_k(M)$. That is, M is not weakly degenerate. \square

Of Proposition 7.2. Let $\hat{\alpha}_0 = \{1, 3\}$. After lengthy but simple computations, we find that the minor $\det \hat{M}_{\hat{\alpha}_0, \hat{\alpha}_0} > 0$ if, and only if, $\gamma > 0$; whereas the remaining principal minors are always positive. Thus, for $\gamma > 0$, \hat{M} is a matrix of class P and the solution of the complementarity problem is unique, regardless of \hat{q} . If, on the other hand, $\gamma < 0$, then the conditions of Corollary 7.1 hold and the result follows. Finally, if $\gamma = 0$, then \hat{M} is degenerate and hence LCP-unstable. \square

Of Proposition 8.2. As mentioned above, the set of Q -matrices is the union of three classes, the classes C_1 , C_3 , and their common boundary. Thus, it suffices to show that there is at least one strictly copositive matrix in each class. To that end, let us consider the set,

$$\Lambda := \left\{ (\theta_1, \theta_2) \mid \theta_1 \in \left(\pi, \frac{3\pi}{2} \right), \text{ and } \theta_2 \in \left(\frac{\pi}{2}, \pi \right) \right\}.$$

The conclusion follows by noting that, for any $(\theta_1, \theta_2) \in \Lambda$, $M(\theta_1, \theta_2)$ is strictly copositive and the fact that Λ intersects the three classes of Q -matrices (see Fig. 8). \square

REFERENCES

- [1] S. Boyd and L. Vandenberghe, *Convex Optimization*. Cambridge, UK: Cambridge University Press, 2006.
- [2] V. Acary, O. Bonnefon, and B. Brogliato, *Nonsmooth modeling and simulation for switched circuits*, ser. Lecture Notes in Electrical Engineering. Springer, 2011.
- [3] S. Adly, *A Variational Approach to Nonsmooth Dynamics: Applications in Unilateral Mechanics and Electronics*. Springer, 2017.
- [4] D. Goeleven, *Complementarity and variational inequalities in electronics*. Academic Press, 2017.
- [5] B. Brogliato, *Nonsmooth mechanics: models, dynamics and control*, 2nd ed. London: Springer-Verlag, 1999.
- [6] A. Nagurney, *Network economics: A variational inequality approach*, ser. Advances in Computational Economics. Springer-Science+Business Media, 1999.
- [7] I. Goodfellow, Y. Bengio, and A. Courville, *Deep learning*. MIT press, 2016.
- [8] M. C. Ferris and J. S. Pang, "Engineering and economic applications of complementarity problems," *SIAM Reviews*, vol. 39, pp. 669 – 713, 1997.
- [9] K. G. Murty, *Linear complementarity, linear and nonlinear programming*. Berlin: Helderman Verlag, 1988.
- [10] G. Isac, *Complementarity Problems*, ser. Lecture Notes in Mathematics. Springer-Verlag, 1992.
- [11] D. M. Leenaerts and W. M. G. Bokhoven, *Piecewise linear modeling and analysis*, ser. Kluwer Academic. New York: Springer, 1998.

- [12] S. C. Billups and K. G. Murty, “Complementarity problems,” *Journal of Computational and Applied Mathematics*, vol. 124, pp. 303 – 318, 2000.
- [13] F. Facchinei and J. S. Pang, *Finite-Dimensional Variational Inequalities and Complementarity Problems*, ser. Springer series in operations research. New York: Springer, 2003, vol. I.
- [14] R. W. Cottle, J. S. Pang, and R. E. Stone, *The Linear Complementarity Problem*, ser. Classics in Applied Mathematics. Society for Industrial and Applied Mathematics, 2009.
- [15] A. J. van der Schaft and J. M. Schumacher, “Complementarity modeling of hybrid systems,” *IEEE Trans. Autom. Control*, vol. 43, pp. 483 – 490, 1998.
- [16] W. P. M. H. Heemels, J. M. Schumacher, and S. Weiland, “Linear complementarity systems,” *SIAM Journal on Applied Mathematics*, vol. 60, no. 4, pp. 1234 – 1269, 2000.
- [17] M. K. Çamlıbel, W. P. M. H. Heemels, and J. M. Schumacher, “On linear passive complementarity systems,” *European Journal of Control*, vol. 8, no. 3, pp. 220–237, 2002.
- [18] B. Brogliato, “Some perspectives on the analysis and control of complementarity systems,” *IEEE Trans. Autom. Control*, vol. 48, no. 6, pp. 918 – 935, 2003.
- [19] R. Casey, H. d. Jong, and J.-L. Gouzé, “Piecewise-linear models of genetic regulatory networks: equilibria and their stability,” *Journal of mathematical biology*, vol. 52, no. 1, pp. 27–56, 2006.
- [20] H. McKean Jr, “Nagumo’s equation,” *Advances in mathematics*, vol. 4, no. 3, pp. 209–223, 1970.
- [21] G. Chen, D. J. Hill, and X. Yu, *Bifurcation control: theory and applications*. Springer Science & Business Media, 2003, vol. 293.
- [22] A. J. Krener, W. Kang, and D. E. Chang, “Control bifurcations,” *IEEE Transactions on Automatic Control*, vol. 49, no. 8, pp. 1231–1246, 2004.
- [23] E. H. Abed and J.-H. Fu, “Local feedback stabilization and bifurcation control, I. Hopf bifurcation,” *Systems & Control Letters*, vol. 7, no. 1, pp. 11–17, 1986.
- [24] —, “Local feedback stabilization and bifurcation control, II. stationary bifurcation,” *Systems & Control Letters*, vol. 8, no. 5, pp. 467–473, 1987.
- [25] G. Chen, J. L. Moiola, and H. O. Wang, “Bifurcation control: theories, methods, and applications,” *International Journal of Bifurcation and Chaos*, vol. 10, no. 03, pp. 511–548, 2000.
- [26] F. Castaños and A. Franci, “Implementing robust neuromodulation in neuromorphic circuits,” *Neurocomputing*, vol. 233, pp. 3–13, 2017.
- [27] A. Franci and R. Sepulchre, “Realization of nonlinear behaviors from organizing centers,” in *53rd IEEE Conference on Decision and Control*. IEEE, 2014, pp. 56–61.
- [28] A. Franci, G. Drion, and R. Sepulchre, “The sensitivity function of excitable feedback systems,” in *2019 IEEE 58th Conference on Decision and Control (CDC)*. IEEE, 2019, pp. 4723–4728.
- [29] R. Gray, A. Franci, V. Srivastava, and N. E. Leonard, “Multiagent decision-making dynamics inspired by honeybees,” *IEEE Transactions on Control of Network Systems*, vol. 5, no. 2, pp. 793–806, 2018.
- [30] A. Franci, A. Bizyaeva, S. Park, and N. E. Leonard, “Analysis and control of agreement and disagreement opinion cascades,” *Swarm Intelligence*, pp. 1–36, 2021.
- [31] A. Bizyaeva, A. Franci, and N. E. Leonard, “Nonlinear opinion dynamics with tunable sensitivity,” *arXiv preprint arXiv:2009.04332*, 2020.
- [32] A. Franci, M. Golubitsky, A. Bizyaeva, and N. E. Leonard, “A model-independent theory of consensus and dissensus decision making,” *arXiv preprint arXiv:1909.05765*, 2019.
- [33] A. Franci, M. Golubitsky, I. Stewart, A. Bizyaeva, and N. Leonard, “Breaking indecision in multi-agent, multi-option dynamics,” *SIAM Journal on Applied Dynamical Systems*, 2023.
- [34] H. K. Khalil, *Nonlinear Systems*. Upper Saddle River, New Jersey: Prentice-Hall, 2002.
- [35] O. Makarenkov and J. Lamb, “Dynamics and bifurcations of nonsmooth systems: A survey,” *Physica D: Nonlinear Phenomena*, vol. 241, no. 22, pp. 1826–1844, 2012.
- [36] M. Di Bernardo, C. Budd, A. Champneys, P. Kowalczyk, A. Nordmark, G. Tost, and P. Pironen, “Bifurcations in nonsmooth dynamical systems,” *SIAM review*, vol. 50, no. 4, pp. 629–701, 2008.
- [37] F. Castaños, F. A. Miranda-Villatoro, and A. Franci, “A notion of equivalence for linear complementarity problems with application to the design of non-smooth bifurcations,” in *21st IFAC World Congress*, 2020.
- [38] B. C. Eaves and C. E. Lemke, “Equivalence of LCP and PLS,” *Mathematics of Operation Research*, vol. 6, no. 4, pp. 475–484, 1981.
- [39] M. Golubitsky and D. G. Schaeffer, *Singularities and Groups in Bifurcation Theory: Volume I*. Springer Science & Business Media, 1985, vol. 51.

- [40] J. Guckenheimer and P. Holmes, *Nonlinear Oscillations, Dynamical Systems and Bifurcations of Vector Fields*. Springer-Verlag, 1983.
- [41] V. Acary, H. de Jong, and B. Brogliato, “Numerical simulation of piecewise-linear models of gene regulatory networks using complementarity systems,” *Physica D*, vol. 269, pp. 103–119, 2014.
- [42] T. L. Carroll, “A simple circuit for demonstrating regular and synchronized chaos,” *American Journal of Physics*, vol. 63, no. 4, pp. 377–379, 1995.
- [43] B. C. Eaves and C. E. Lemke, “On the equivalence of the linear complementarity problem and a system of piecewise linear equations: part II,” in *Homotopy Methods and Global Convergence*, B. C. Eaves, F. J. Gould, H.-O. Peitgen, and M. J. Todd, Eds. Plenum Publishing Corporation, 1981, pp. 79–90.
- [44] F. A. Miranda-Villatoro, B. Brogliato, and F. Castaños, “Set-valued sliding-mode control of uncertain linear systems: continuous and discrete-time analysis,” *SIAM Journal on Control and Optimization*, vol. 56, no. 3, pp. 1756–1793, 2018.
- [45] B. Brogliato and A. Tanwani, “Dynamical systems coupled with monotone set-valued operators: formalisms, applications, well-posedness, and stability,” *SIAM Review*, vol. 62, no. 1, pp. 3 – 129, 2020.
- [46] N. Papageorgiou, “Differential inclusions with state constraints,” *Proceedings of the Edinburgh Mathematical Society*, vol. 32, pp. 81–98, 1989.
- [47] L. O. Chua, J. Yu, and Y. Yu, “Negative resistance devices: Part I,” *Circuit Theory and Applications*, vol. 11, pp. 161 – 186, 1983.
- [48] I. E. Getreu, *Modeling the Bipolar Transistor*. Amsterdam, The Netherlands: Elsevier Scientific Publishing Company, 1978.
- [49] R. A. Danao, “Q-matrices and boundedness of solutions to linear complementarity problems,” *Journal of Optimization Theory and Applications*, vol. 83, no. 2, pp. 321–332, 1994.
- [50] R. D. Doverspike, “Some perturbation results for the linear complementarity problem,” *Mathematical Programming*, vol. 23, pp. 181 – 192, 1982.
- [51] C. B. Garcia, F. J. Gould, and T. R. Turnbull, “Relations between PL maps, complementary cones, and degree in linear complementarity problems,” in *Homotopy Methods and Global Convergence*, B. C. Eaves, F. J. Gould, H.-O. Peitgen, and M. J. Todd, Eds. Plenum Publishing Corporation, 1981, pp. 91–144.
- [52] R. Howe and R. Stone, “Linear complementarity and the degree of mappings,” in *Homotopy Methods and Global Convergence*, B. C. Eaves, F. J. Gould, H.-O. Peitgen, and M. J. Todd, Eds. Plenum Publishing Corporation, 1981, pp. 91–144.
- [53] M. S. Gowda, “On the continuity of the solution map in linear complementarity problems,” *SIAM Journal on Optimization*, vol. 2, no. 4, pp. 619–634, 1992.
- [54] S. M. Robinson, “Strongly regular generalized equations,” *Mathematics of Operations Research*, vol. 5, no. 1, 1980.
- [55] F. H. Clarke, *Optimization and nonsmooth analysis*. Society for Industrial and Applied Mathematics, 1990.
- [56] S. Givant and P. R. Halmos, *Introduction to Boolean Algebras*. New York: Springer-Verlag, 2009.
- [57] R. Sikorski, *Boolean Algebras*. Berlin, Germany: Springer-Verlag, 1969.
- [58] V. I. Arnold, A. N. Varchenko, and S. M. Gusein-Zade, *Singularities of Differentiable Maps*. Birkhäuser, 1985, vol. 1.
- [59] H. Samelson, R. M. Thrall, and O. Wesler, “A partition theorem for Euclidean n -space,” *Proceedings of the American Mathematical Society*, vol. 9, no. 5, pp. 805 – 807, 1958.
- [60] R. G. Regis, “On the properties of positive spanning sets and positive bases,” *Optimization and Engineering*, vol. 17, pp. 229 – 262, 2016.
- [61] F. Forni and R. Sepulchre, “Differential dissipativity theory for dominance analysis,” *IEEE Trans. Autom. Control*, vol. 64, pp. 2340 – 2351, 2019.
- [62] F. A. Miranda-Villatoro, F. Forni, and R. Sepulchre, “Dominance analysis of linear complementarity systems,” in *23rd International Symposium on Mathematical Theory of Networks and Systems*, 2018.
- [63] R. W. Cottle, “A field guide to the matrix classes found in the literature of the linear complementarity problem,” *Journal of Global Optimization*, vol. 46, pp. 571 – 580, 2010.
- [64] R. W. Cottle and G. B. Dantzig, “Complementary pivot theory of mathematical programming,” *Linear Algebra and its Applications*, vol. 1, pp. 103–125, 1968.