



HAL
open science

Treelength of Series-parallel graphs

Thomas Dissaux, Guillaume Ducoffe, Nicolas Nisse, Simon Nivelle

► **To cite this version:**

Thomas Dissaux, Guillaume Ducoffe, Nicolas Nisse, Simon Nivelle. Treelength of Series-parallel graphs. LAGOS 2021 - XI Latin and American Algorithms, Graphs and Optimization Symposium, May 2021, São Paulo / Virtual, Brazil. 10.1016/j.procs.2021.11.008 . hal-03175837

HAL Id: hal-03175837

<https://inria.hal.science/hal-03175837>

Submitted on 21 Mar 2021

HAL is a multi-disciplinary open access archive for the deposit and dissemination of scientific research documents, whether they are published or not. The documents may come from teaching and research institutions in France or abroad, or from public or private research centers.

L'archive ouverte pluridisciplinaire **HAL**, est destinée au dépôt et à la diffusion de documents scientifiques de niveau recherche, publiés ou non, émanant des établissements d'enseignement et de recherche français ou étrangers, des laboratoires publics ou privés.

Treelength of Series-parallel graphs

Thomas Dissaux, Guillaume Ducoffe, Nicolas Nisse, Simon Nivelle

► **To cite this version:**

Thomas Dissaux, Guillaume Ducoffe, Nicolas Nisse, Simon Nivelle. Treelength of Series-parallel graphs. [Research Report] Inria & Université Cote d'Azur, CNRS, I3S, Sophia Antipolis, France. 2020. hal-03010346

HAL Id: hal-03010346

<https://hal.archives-ouvertes.fr/hal-03010346>

Submitted on 17 Nov 2020

HAL is a multi-disciplinary open access archive for the deposit and dissemination of scientific research documents, whether they are published or not. The documents may come from teaching and research institutions in France or abroad, or from public or private research centers.

L'archive ouverte pluridisciplinaire **HAL**, est destinée au dépôt et à la diffusion de documents scientifiques de niveau recherche, publiés ou non, émanant des établissements d'enseignement et de recherche français ou étrangers, des laboratoires publics ou privés.

Treelength of Series-parallel graphs*

Thomas Dissaux¹, Guillaume Ducoffe², Nicolas Nisse¹, and Simon Nivelles³

¹Université Côte d’Azur, CNRS, Inria, I3S, Sophia Antipolis, France

²University of Bucharest & National Institute of Research and Development in Informatics, Romania

³INSPÉ Paris, Sorbonne Université, France

November 17, 2020

Abstract

The *length* of a *tree-decomposition* of a graph is the maximum distance between two vertices of a same bag of the decomposition. The *treelength* of a graph is the minimum length among its tree-decomposition. Treelength of graphs has been studied for its algorithmic applications in classical metric problems such as Traveling Salesman Problem or metric dimension of graphs and also, in compact routing in the context of distributed computing. Deciding whether the treelength of a general graph is at most 2 is NP-complete (graphs of treelength one are precisely the chordal graphs), and it is known that the treelength of a graph cannot be approximated up to a factor less than $\frac{3}{2}$ (the best known approximation algorithm for treelength has an approximation ratio of 3). However, nothing is known on the computational complexity of treelength in planar graphs, except that the treelength of any outerplanar graph is equal to the third of the maximum size of its isometric cycles. This work initiates the study of treelength in planar graphs by considering its next natural subclass, namely the one of series-parallel graphs.

We first fully describe the treelength of melon graphs (set of pairwise internally disjoint paths linking two vertices), showing that, even in such a restricted graph class, the expression of the treelength is not trivial. Then, we show that treelength can be approximated up to a factor $\frac{3}{2}$ in series-parallel graphs. Our main result is a polynomial-time algorithm for deciding whether a series-parallel graph has treelength at most 2. Our latter result relies on a characterization of series-parallel graphs with treelength 2 in terms of an infinite family of forbidden isometric subgraphs.

1 Introduction

Treewidth. *Tree-decompositions* of graphs have been initially introduced by Halin [18] and then rediscovered as part of the Graph Minor Theory by Robertson and Seymour [23]. Roughly speaking, a tree-decomposition of a graph describes it using a set of subsets (called *bags*) of its

*T. Dissaux and N. Nisse are partly funded by STIC-AmSud project GALOP, PHC Xu Guangqi project DESPROGES, the UCA^{JEDI} Investments in the Future project managed by the National Research Agency (ANR-15-IDEX-01), the ANR project MULTIMOD (ANR-17-CE22-0016) and the ANR project Digraphs (ANR-19-CE48-0013).

G. Ducoffe was supported by project PN 19 37 04 01 “New solutions for complex problems in current ICT research fields based on modelling and optimization”, funded by the Romanian Core Program of the Ministry of Research and Innovation (MCI) 2019-2022, and by a grant of Romanian Ministry of Research and Innovation CCCDI-UEFISCDI. project no. 17PCCDI/2018.

vertices that are organized in a tree-like fashion. The classical measure of a tree-decomposition is its *width*, i.e., the maximum size (minus one) of its bags, and the *treewidth*, denoted by $tw(G)$, of a graph G is the minimum width of its tree-decompositions. Tree-decompositions have been extensively studied due to their various algorithmic applications. For instance, numerous NP-hard problems can be solved in linear time in bounded treewidth graphs [3, 8]; tree-decompositions are used as part of many efficient parametrized algorithms [5]; they play a crucial role in the design of sub-exponential algorithms in the context of bi-dimensionality [10], *etc.* (see [9, 12] for more details).

To make the most of previous results, being able to compute tree-decompositions with small width is an important pre-requisite. Unfortunately, computing the treewidth of an n -node graph G is NP-hard [1] and the best known approximation algorithm has approximation-ratio $O(\sqrt{\log tw(G)})$ [17]. While computing the treewidth is *FPT*, i.e., deciding whether $tw(G) \leq k$ can be solved in time $O(2^{k^3} n)$ [6], the latter algorithm cannot be used in practice since it is super-exponential in k and due to the large constant hidden in the “big O ”. On the positive side, an integer k being fixed, there exists an algorithm that, given an input n -node graph G , decides if $tw(G) > k$ or computes a tree-decomposition of G with width at most $5k$ in time $O(2^k n)$ [4]. The case of planar graphs is particularly interesting since, while approximation algorithms exist [19, 24], the status of the computational complexity of treewidth in planar graphs is open since 30 years.

Treelength. Appart from its width, other parameters have been proposed as “measures” of a tree-decomposition. In particular, the *length* (resp., *breadth*) of a tree-decomposition is the maximum *diameter* (resp., *radius*) of its bags. The *treelength* of a graph G , denoted by $tl(G)$, is then the minimum length of its tree-decomposition [13] and the *treewidth* is defined accordingly [14]. Both treelength and treewidth also have algorithmic interests. For instance, the *Traveling Salesman Problem* admits a FPTAS in bounded treelength graphs [21]; *metric dimension* is FPT in the treelength [2]; efficient compact routing schemes and sparse additive spanners can be built in the class of bounded treelength or bounded treewidth graphs [13, 14, 20], *etc.* Unfortunately, both these parameters are not even FPT since deciding if a graph has treelength at most two (resp., has treewidth at most one) is NP-complete [15, 22]. On the positive side, both parameters can be efficiently approximated: treelength can be approximated up to a factor 3 using a BFS-like algorithm [13] (the approximation for treewidth follows since the treelength of a graph is at most twice its treewidth). Concerning treelength and treewidth of planar graphs, very few is known. In [15], it was shown that deciding whether the treewidth is at most one can be solved in polynomial-time in the class of $K_{3,3}$ -minor-free graphs. The treelength of an *outerplanar* graph equals the third of its largest *isometric* cycle [13], but it is not even known whether deciding if the treelength of a planar graph is at most two can be solved in polynomial-time.

This paper initiates the study of computational complexity of treelength in planar graphs by considering its next (after outerplanar graphs) natural subclass, namely in *series-parallel* graphs [16, 25].

Relationship between treewidth and treelength. Another motivation for this work is that achieving exact (or better approximation) algorithms for computing the treelength may lead toward better (more efficient or with better approximation ratio) approximation algorithms for computing the treewidth in large graph classes. In general, treewidth and treelength are not comparable. The treewidth of any n -node cycle equals 2 while its treelength equals $\lceil \frac{n}{3} \rceil$ [13]. On the other hand, the treewidth of the complete graph with n vertices equals $n - 1$ while its treelength equals one. However, these graph classes (cycles and complete graphs) are somehow the extreme cases since it has been proved that, in the class of graphs G excluding an *apex*

graph as minor (including planar graphs) and with bounded largest isometric cycle, $tw(G) = \Theta(tl(G))$ [7]. More specifically, [11] presents a polynomial-time algorithm that, given a tree-decomposition of length ℓ of a planar graph G , computes tree-decomposition of width at most 9ℓ for G . Therefore, computing tree-decompositions with “small” length would imply “good” approximation algorithms for the treewidth of planar graphs.

Our contributions. We focus on the computation of the treelength in series-parallel graphs. Section 2 is devoted to the formal definitions of the main concepts used throughout the paper. In Section 3, we consider *melon* graphs, i.e., series-parallel graphs G obtained by identifying the endpoints of pairwise internally disjoint paths $(P_i)_{i \leq p}$ of respective length ℓ_i (with $\ell_1 \geq \dots \geq \ell_p$). We show that, in any melon graph G , $tl(G) = \min\{\lceil \frac{lc(G)}{3} \rceil, \max\{\lceil \frac{is(G)}{3} \rceil, \ell_p\}\}$ where $is(G)$ (resp., $lc(G)$) is the size of a largest isometric (resp., of a largest) cycle in G . Moreover, we exhibit an example of series-parallel graph for which it seems harder to link the treelength to the size of its maximum (isometric) cycles. In our next results, we make use of the *nested ear-decompositions* [16] of series-parallel graphs. In Section 4, we design a $\frac{3}{2}$ -approximation algorithm for computing the treelength of series-parallel graphs. In Section 5, our main result is that a series-parallel graph G has treelength at most two if and only if its largest isometric cycle has length at most 6 and G has no *Dumbo graph* (see definition below) as isometric subgraph. This characterization leads to a polynomial-time algorithm that decides if a series-parallel graph has treelength at most two. Finally, we conclude in Section 6 by discussing how our results may be generalized to compute treelength of series-parallel graphs.

2 Preliminaries

In this paper, we consider only undirected unweighted simple (without loops nor parallel edges) graphs. A graph $G = (V, E)$ is *connected* if, for every $u, v \in V$, there exists a path between u and v in G . We now only consider connected graphs. For any $v \in V$, let $N_G(v)$ be the neighbors of v in G (i.e. $N_G(v) = \{w \in V(G) \mid (v, w) \in E(G)\}$) and let $N_G(S)$ be the set of vertices in G adjacent to a vertex in S (i.e. $N_G(S) = \bigcup_{v \in S} N_G(v) \setminus S$). The *distance* $d_G(u, v)$ in $G = (V, E)$ between two vertices $u, v \in V$ equals the minimum *length* (number of edges) of a path linking u and v in G , and $P_G(u, v)$ denotes any shortest u, v -path. The *diameter* of G is the maximum distance between its vertices, i.e., $\max_{u, v \in V} d_G(u, v)$. A *subgraph* $H = (V(H) \subseteq V, E(H) \subseteq E \cap (V(H) \times V(H)))$ of G is *isometric* if $d_H(u, v) = d_G(u, v)$ for every $u, v \in V(H)$, i.e., if H *preserves* the distances of G . Let $is(G)$ be the largest size of an isometric cycle in G .

Tree-decompositions. A *tree-decomposition* of a graph $G = (V, E)$ is a pair $(T, \mathcal{X} = \{X_t \mid t \in V(T)\})$ such that T is a tree, and \mathcal{X} is a set of subsets (called *bags*) of vertices of G , indexing the nodes of T such that:

- $\bigcup_{t \in V(T)} X_t = V(G)$;
- for every $\{u, v\} \in E(G)$, there exists $t \in V(T)$ such that $u, v \in X_t$;
- for every $v \in V(G)$, the set $\{t \in V(T) \mid v \in X_t\}$ induces a subtree of T .

We may further assume that (T, \mathcal{X}) is *reduced*, i.e., no bag is included in another one. The *width* of (T, \mathcal{X}) equals $\max_{t \in V(T)} |X_t| - 1$, i.e., the largest size (minus one) of the bags of (T, \mathcal{X}) . The *treewidth* $tw(G)$ of G is the minimum width of the tree-decompositions of G . The *length*, denoted by $length(T, \mathcal{X})$, of (T, \mathcal{X}) equals $\max_{t \in V(T)} \max_{u, v \in X_t} d_G(u, v)$, i.e., the maximum diameter (in G) of its bags. The *treelength* $tl(G)$ of G is the minimum length of the tree-decompositions of G .

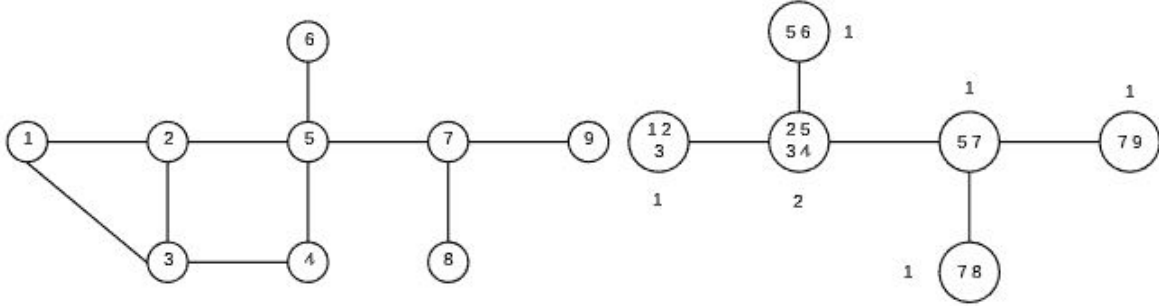

Figure 1: Example of a tree-decomposition (T, \mathcal{X}) (right) of minimum length for the graph G (left) with each bag's diameters (integer outside the bags).

In what follows, we will use the following lemma that follows from the fact that $tl(C_n) = \lceil \frac{n}{3} \rceil$ for any n -node cycle C_n [13].

Lemma 1 [13] *Let G be any graph and H be any isometric subgraph of G . Then, $tl(H) \leq tl(G)$. In particular, $tl(G) \geq \lceil \frac{is(G)}{3} \rceil$.*

Given a connected graph $G = (V, E)$, a set $S \subset V$ is a *separator* if $G \setminus S$ (obtained from G by removing the vertices of S) is not connected. It is well known that, in any reduced tree-decomposition, the intersection between two adjacent bags is a separator of the graph. The set S is a *clique separator* of G if moreover the subgraph $G[S]$ induced by S in G is a complete graph. It is easy to show that, for any graph G with a clique separator S and \mathcal{C} being the set of connected components of $G \setminus S$, then $tw(G) = \max_{C \in \mathcal{C}} tw(G[C \cup S])$ and $tl(G) = \max_{C \in \mathcal{C}} tl(G[C \cup S])$.

A graph G is called *prime* if it does not admit any clique separator. Therefore, from now on, we will only consider prime graphs. In particular, we only consider *2-connected* graphs, i.e., graphs with no separator of size one.

Series-parallel graphs. An (s, t) -series-parallel graph is any graph (with two distinguished vertices s and t) recursively defined as follows. An edge st is a (s, t) -series-parallel graph. Moreover, given an (s_1, t_1) -series-parallel graph G_1 and an (s_2, t_2) -series-parallel graph G_2 , a (s, t) -series-parallel graph G can be obtained from G_1 and G_2 either:

serie composition: by identifying t_1 and s_2 (in which case $s = s_1$, and $t = t_2$) or,

parallel composition: by identifying s_1 and s_2 on the one hand, and t_1 and t_2 on the other hand (in which case $s = s_1 = s_2$, and $t = t_1 = t_2$).

A graph $G = (V, E)$ is *series-parallel* if there are two vertices $s, t \in V$ such that G is an (s, t) -series-parallel graph. It is well known that a graph is K_4 -minor free, or equivalently has treewidth at most 2, if and only if its 2-connected components are series-parallel []. Note that outerplanar graphs are precisely $(K_4, K_{2,3})$ -minor free graphs and so 2-connected outerplanar graphs are included in the class of series-parallel graphs.

Note that, in any series-parallel graph G , a largest isometric cycle (and so $is(G)$) can be computed in linear time by a simple dynamic programming algorithm (using a recursive sequence of compositions that can be obtained in linear time [25]).

Ear-decompositions. An *ear-decomposition* of a graph $G = (V, E)$ is a partition (E_0, E_1, \dots, E_p) of E such that E_0 induces a cycle in G and, for every $1 \leq i \leq p$, E_i induces a path between

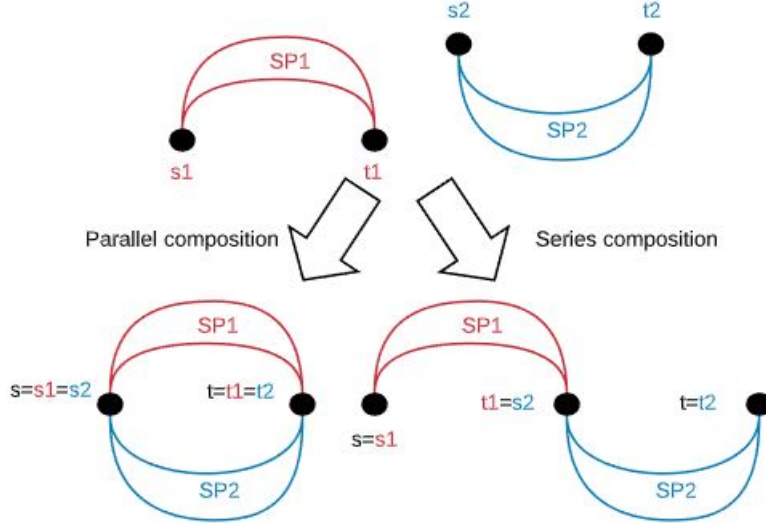

Figure 2: Series and parallel composition for two series-parallel graph

two vertices a_i and b_i in G . Moreover, $V(E_i) \cap V(G_{i-1}) = \{a_i, b_i\}$ where G_{i-1} is the subgraph induced by $\bigcup_{j \leq i-1} V(E_j)$ (that is, the path induced by E_i is internally disjoint from $V(E_0), \dots, V(E_{i-1})$). We say that a_i and b_i are the *attachment vertices* of E_i in G_{i-1} . It is well known that a graph admits an ear decomposition if and only if it is 2-connected [12].

An ear decomposition is *nested* if moreover, for every $1 \leq i \leq i' \leq p$:

- the attachment vertices a_i and b_i of E_i appear in a previous ear E_j , with $j < i$, *i.e.* there exists $j < i$ such that $a_i, b_i \in V(E_j)$, in which case we say that E_i is attached to E_j . Let j_i be the smallest index $0 \leq j < i$ such that E_i is attached to E_j , and
- if two ears E_i and $E_{i'}$ are both attached to some ear E_j , then either the path $P_{E_j}(a_i, b_i)$ between a_i and b_i in E_j contains (not necessarily properly) $P_{E_j}(a_{i'}, b_{i'})$, or vice versa, or $P_{E_j}(a_i, b_i)$ and $P_{E_j}(a_{i'}, b_{i'})$ are internally vertex-disjoint. That is, two ears “do not cross” each other.

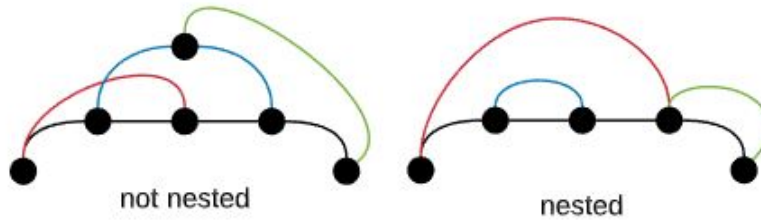

Figure 3: Example of nested and not nested ears

A graph is a 2-connected series-parallel graph if and only if it admits a nested ear decomposition [16]. It is easy to prove that we may further assume that E_0 is a largest isometric cycle of G and that, for every $1 \leq i \leq p$, $|E_i| \geq |P_{E_{j_i}}(a_i, b_i)|$, *i.e.*, equivalently that G_i is an isometric

subgraph of G for every $1 \leq i \leq p$. A nested ear-decomposition satisfying the latter condition is called *increasing*.

Lemma 2 *For any 2-connected series-parallel graph G , an increasing nested ear decomposition starting from a maximum isometric cycle of G can be computed in quadratic time.*

Proof. First, note that we can compute in polynomial time a maximal isometric cycle C of G and its length. Then we can compute an increasing nested ear decomposition of G in polynomial time as follow:

- Step E_0 : $G_0 = G[V(C)]$
- Step E_i : with $1 \leq i \leq p$: Let C_1, \dots, C_k be the k connected component of $G \setminus G_{i-1}$. Let C^* be any component C_j for any $1 \leq j \leq k$ union $V(N_{G_{i-1} \cup C_j}(C_j))$. Note that $V(N_{G_{i-1} \cup C_j}(C_j)) = \{a_i, b_i\}$. Let E_i be a shortest path between a_i and b_i and $G_i = G[V(G_{i-1}) \cup V(E_i)]$

Note that since we define E_i as a shortest path, it is impossible that an ear E'_i is attached to E_i such that $|E'_i| < |P_{E_i}(a_i, b_i)|$. ■

3 Simple series-parallel graphs

This section is devoted to the simplest (including the cycles) subclass of 2-connected series-parallel graphs that we call the *melon* graphs. A *melon* graph is any graph $G = (P_1, \dots, P_p)$ obtained from two vertices x and y by adding $p \geq 2$ internally vertex-disjoint paths P_1, \dots, P_p between x and y . In what follows, let $\ell_i = |P_i|$ be the length of P_i for every $1 \leq i \leq p$ and, w.l.o.g., let us assume that $\ell_1 \geq \dots \geq \ell_p > 0$. Note that a largest isometric cycle of G consists of P_1 and P_p and so $is(G_S) = \ell_1 + \ell_p$ and that a largest cycle consists of P_1 and P_2 and has size $lc(G) = \ell_1 + \ell_2 \geq is(G)$.

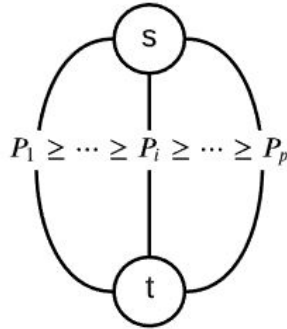

Figure 4: melon graphs

Theorem 1 *For any melon graph $G = (P_1, \dots, P_p)$, $tl(G) = \min\{\lceil \frac{lc(G)}{3} \rceil; \max\{\lceil \frac{is(G)}{3} \rceil, |P_p|\}\}$.*

Proof. Let us first show the upper bounds in each of the three cases: $\ell_p = |P_p| \leq \lceil \frac{is(G)}{3} \rceil$ (in which case we aim at proving that $tl(G) = \lceil \frac{is(G)}{3} \rceil$); $\lceil \frac{is(G)}{3} \rceil \leq \ell_p \leq \lceil \frac{lc(G)}{3} \rceil$ (in which case $tl(G) = \ell_p$); and $\lceil \frac{lc(G)}{3} \rceil \leq \ell_p$ (in which case $tl(G) = \lceil \frac{lc(G)}{3} \rceil$).

- First, let us assume that $\ell_p \leq \lceil \frac{\ell_1 + \ell_p}{3} \rceil$. Let $I_1 = \{1 \leq i < p \mid \ell_i > \lceil \frac{\ell_1 + \ell_p}{3} \rceil - \ell_p\}$ and let $I_2 = \{1, \dots, p-1\} \setminus I_1$. Note that, for any $i \in I_2$, $\ell_i = |P_i| \leq \lceil \frac{\ell_1 + \ell_p}{3} \rceil$.

For any $i \in I_1$, let z_i be the vertex of P_i such that the subpath P'_i of P_i from x to z_i has length $\lceil \frac{\ell_1 + \ell_p}{3} \rceil - \ell_p$ and does not pass through y (possibly $z_i = x$). The path $P_p \cup P'_i$ going from y to z_i and passing through x has length $\lceil \frac{is(G)}{3} \rceil$. For any $i \in I_1$, let $P''_i = (P_i \setminus P'_i) \cup z_i$ and let γ_i be the "central vertex" of P''_i , i.e., such that $d_{P''_i}(\gamma_i, z_i) = \lfloor \frac{|P''_i|}{2} \rfloor$. Let Q_i (resp. Q'_i) be the subpath of P''_i going from γ_i to z_i (resp., to y_i). Note that $|Q_i| \leq |Q'_i| = \lceil \frac{\ell_p + \ell_i - \lceil \frac{\ell_1 + \ell_p}{3} \rceil}{2} \rceil \leq \lceil \frac{\ell_1 + \ell_p}{3} \rceil$.

For any $i \in I_2$, let $z_i = x$ and $V(P'_i) = \{z_i\}$ and $P''_i = P_i$. Then Q_i and Q'_i are then defined similarly as above. By definition of I_2 , $|Q_i| \leq |Q'_i| \leq |P_i| \leq \lceil \frac{\ell_1 + \ell_p}{3} \rceil$.

Let us build a tree-decomposition as follows. Start with a bag $X_0 = V(P_p)$. For every $1 \leq i < p$, add a bag $X_i^1 = X_0 \cup V(P'_i)$ adjacent to X_0 , then a bag $C_i = \{z_i, \gamma_i, y\}$ adjacent to X_i^1 and two bags $X_i^2 = V(Q_i)$ and $X_i^3 = V(Q'_i)$ both adjacent to C_i . By previous paragraph, this is a tree-decomposition with length $\lceil \frac{\ell_1 + \ell_p}{3} \rceil$ (see Figure 5).

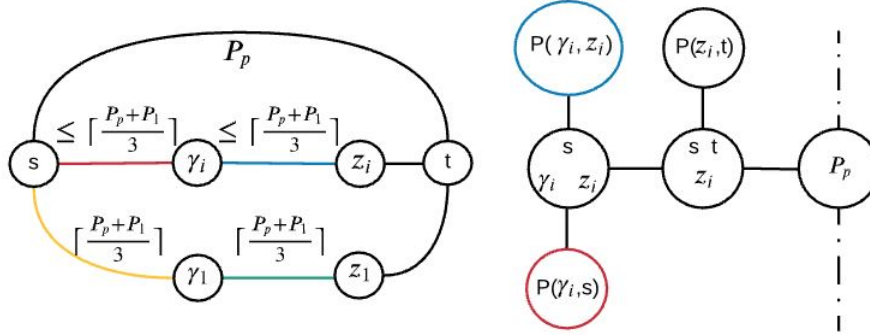

Figure 5: case $\ell_n \leq \lceil \frac{\ell_1 + \ell_n}{3} \rceil$

- Let us assume that $\lceil \frac{\ell_1 + \ell_p}{3} \rceil \leq \ell_p \leq \lceil \frac{\ell_1 + \ell_2}{3} \rceil$. The tree-decomposition is obtained as in the previous case with the only difference that $z_i = x$ for every $1 \leq i \leq p$ (i.e., $P'_i = \{z_i\}$ for every i). This is a tree-decomposition with length ℓ_p (see Figure 6).

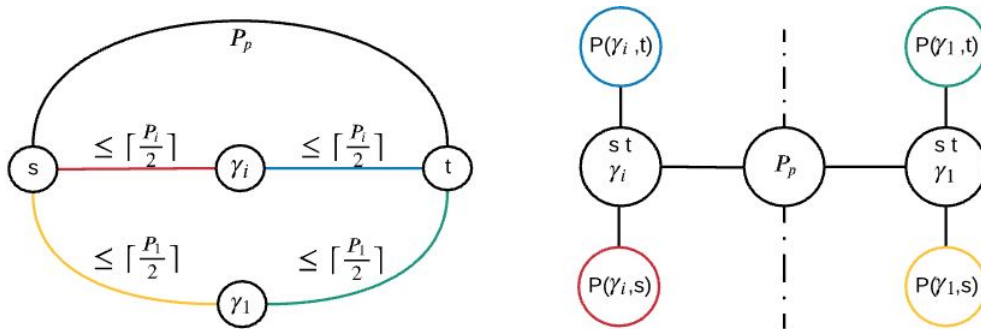

Figure 6: case $\lceil \frac{\ell_1 + \ell_n}{3} \rceil \leq \ell_n \leq \lceil \frac{\ell_1 + \ell_2}{3} \rceil$

- Finally, let us consider the case when $\lceil \frac{\ell_1 + \ell_2}{3} \rceil < \ell_p$. For every $1 \leq i \leq p$, let γ_i be the vertex of P_i at distance $\lceil \frac{\ell_1 + \ell_2}{3} \rceil < \ell_p$ from x and let P'_i be the subpath of P_i which is a shortest path from x to γ_i . For every $1 \leq i, j \leq p$, $d_G(\gamma_i, \gamma_j) \leq \lceil \frac{\ell_1 + \ell_2}{3} \rceil$ (via the shortest path going through y). Let Q be the subtree induced by $\{x, \gamma_1, \dots, \gamma_p\}$ and the connected component of $G \setminus \{x, \gamma_1, \dots, \gamma_p\}$ that contains y .

Let us build a tree-decomposition as follows. Start with a bag $X_0 = \{x, \gamma_1, \dots, \gamma_p\}$. For every $1 \leq i \leq p$, add a bag $X_i = V(P'_i)$ adjacent to X_0 . Finally, add a bag $X_{p+1} = V(Q)$ adjacent to X_0 . This is a tree-decomposition with length $\lceil \frac{\ell_1 + \ell_2}{3} \rceil$ (see Figure 7).

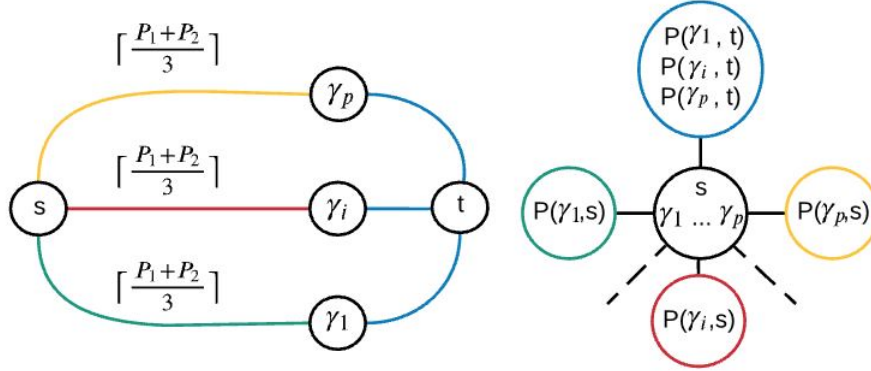

Figure 7: case $\lceil \frac{\ell_1 + \ell_2}{3} \rceil < \ell_n$

Now, let us prove the lower bounds. By Lemma 1, in all cases, $tl(G) \geq \lceil \frac{is(G)}{3} \rceil = \lceil \frac{\ell_1 + \ell_p}{3} \rceil$. We now prove that, if $\ell_p > \lceil \frac{\ell_1 + \ell_p}{3} \rceil$, then $tl(G) \geq \min\{\ell_p, \lceil \frac{\ell_1 + \ell_2}{3} \rceil\}$. For purpose of contradiction, let us assume that $tl(G) < k$ for some $k \leq \min\{\ell_p, \lceil \frac{\ell_1 + \ell_2}{3} \rceil\}$ and consider a tree-decomposition (T, \mathcal{B}) of G with minimum length. Let α (resp. β) be the vertex at distance k from x on $P_1 \setminus y$ (resp. on $P_2 \setminus y$). Note that α and β are well defined since either $\ell_1 \geq \ell_2 \geq \ell_p > \lceil \frac{\ell_1 + \ell_2}{3} \rceil \geq k$ or $\lceil \frac{\ell_1 + \ell_2}{3} \rceil \geq \ell_p > \lceil \frac{\ell_1 + \ell_p}{3} \rceil$ and so $\ell_1 \geq \ell_2 > \ell_p \geq k$. Since $k \leq \min\{\ell_p, \lceil \frac{\ell_1 + \ell_2}{3} \rceil\}$, $d_G(\alpha, \beta) \geq k$ and therefore, no bag of (T, \mathcal{B}) can contain at least two of x, α and β . Let B_x, B_α and B_β be three bags containing x, α and β respectively. There are several cases to be considered.

- First, let us assume that B_x is on the path of T between B_α and B_β . Therefore, α and β must be in different connected components of $G \setminus B_x$. Hence, B_x must contain a vertex of the path from α to β going through y (and not through x). Every vertex of this path is at distance at least k from x , a contradiction.
- Second, assume that B_α is on the path of T between B_x and B_β . Therefore, x and β must be in different connected components of $G \setminus B_\alpha$. Hence, B_α must contain a vertex of the path from x to β not going through y . Every vertex of this path is at distance at least k from α , a contradiction.
- Finally, assume that there is a bag B such that B_x, B_α and B_β are each in distinct connected component of $T \setminus B$. The set B must separate x, α and β . Therefore, B must contain a vertex in each of the three paths from x to α (not going through y), from x to β (not going through y) and from α to β going through y (and not through x). Since the cycle $P_1 \cup P_2$ containing these three vertices has length at least $3k \leq \ell_1 + \ell_2$ and $k \leq |P_p| = \ell_p$, at least two of these three vertices are at distance at least k , a contradiction.

■

The above result lets think that the treelength of series-parallel graphs cannot be expressed by a “nice” formula (such that in the case of outerplanar graphs). The next subclass of series-parallel graphs (with only four vertices with degree larger than 2, see Figure 8) lets think that the situation is even worse. Let $p \geq 1$. Let G_p be the graph obtained from a cycle of length $16p$ and let a, b, c, d be four distinct vertices of it such that $d(a, b) = d(c, d) = 4p$ and $d(a, d) = d(b, c) = 2p$. Then, add one path of length $8p$ from a to b and one path of length $8p$ from c to d . Note that $is(G) = 12p$, that its largest cycle has length $20p$, all other cycles have length $16p$ and that its maximal subpaths with internal vertices of degree 2 have length $2p, 4p$ or $8p$. By similar arguments as in previous proof, it can be shown that $tl(G_p) = 5p$ which seems not directly related to the invariants previously mentioned.

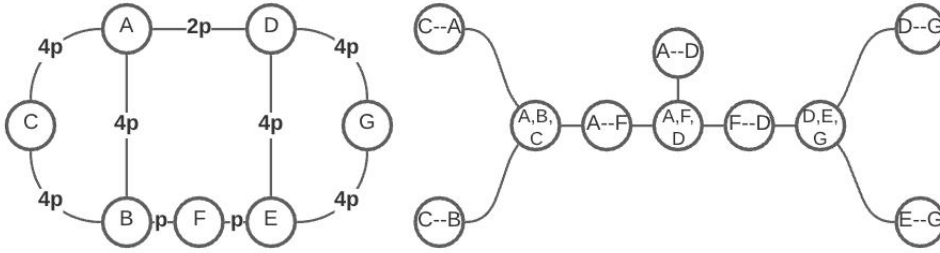

Figure 8: The graph G_p (left) and a tree-decomposition of length $5p$ (right)

Lemma 3 For any $p \in \mathbb{N}^*$, $tl(G_p) = 5p$.

Proof. Let us build a tree-decomposition as follows (see Figure 8). Start with a bag $X_0 = \{A, B, C\}$. Add two bags adjacent to X_0 containing respectively the shortest subpath of K between A and C , and the shortest subpath of K between B and C . Then, add a bag X_1 , adjacent to X_0 , containing the shortest subpath of K between A and B , and the shortest subpath of P between B and F (the diameter of this bag is $5p$). Add the bag $X_2 = \{A, D, F\}$ adjacent to X_1 . Add a bag, adjacent to X_2 , containing the shortest path from A to D (subpath of P). Add the bag X_3 , adjacent to X_2 , containing the shortest path (subpath of P) from D to F (this bag has also diameter $5a$). Then, add the bag $X_4 = \{D, E, G\}$ adjacent to X_3 . Finally, add the bags, adjacent to X_4 , containing respectively the shortest path from D to G in Q , and from E to G . This tree-decomposition has length $5p$. To prove the lower bound, let us consider the vertices A, F and G . In any tree-decomposition of length $< 5p$, no bag can contain at least two of these vertices. Let B_A, B_F and B_G be some bags containing respectively A, F and G in such a decomposition (that we suppose to exist for purpose of contradiction). There are several cases to be considered.

- First, let us assume that B_F is on the path of T between B_A and B_G . Therefore, A and G must be in different connected components of $G_p \setminus B_F$. Hence, B_F must contain a vertex of the shortest path from A to G going through D . Every vertex of this path is at distance at least $5p$ from F , a contradiction.
- Second, assume that B_A is on the path of T between B_F and B_G . Therefore, F and G must be in different connected components of $G_p \setminus B_A$. Hence, B_A must contain a vertex of the shortest path from G to F not going through E . Every vertex of this path is at distance at least $5p$ from A , a contradiction.

- Then, assume that B_G is on the path of T between B_F and B_A . Therefore, F and A must be in different connected components of $G_p \setminus B_G$. Hence, B_G must contain a vertex of the shortest path from A to F not going through B . Every vertex of this path is at distance at least $5p$ from G , a contradiction.
- Finally, assume that there is a bag B_0 such that B_A , B_G and B_F are each in distinct connected components of $T \setminus B_0$. The set B_0 must separate A , F and G . There are several cases to be considered.
 - Assume first that B_0 contains a vertex v of the shortest path between B and A . B_0 must also contain a vertex u of the shortest path from G to A (containing D). For $d_G(v, u) < 5p$, then $d_G(A, u) \leq a$. Finally, B_0 must contain a vertex on the shortest path from G to F (going through E) which are all at distance at least $5p$ from u , a contradiction.
 - Otherwise, B_0 must contain a vertex v of the shortest path from B to A . B_0 must also contain a vertex u of the path between A and G (containing D) and a vertex w of the path from F to G (through E). For $d_G(u, w) < 5p$, then $d_G(A, u) > a$. For $d_G(v, u) < 5p$, v must be between A and C . Hence $d_G(v, w) > 5p$, a contradiction.

■

4 Approximation algorithm

This section shows that, even if it is still unknown whether computing the treelength of series-parallel graphs can be done in polynomial time, there exists an efficient approximation algorithm using ear-decompositions.

Theorem 2 *For any series-parallel graph G , a tree-decomposition of G with length at most $\frac{3}{2} \cdot tl(G)$ can be computed in quadratic time.*

Proof. By a remark in Section 2, it is sufficient to consider 2-connected graphs. Let G be a 2-connected series-parallel graph. It follows from lemma 1 that $tl(G) \geq \lceil \frac{is(G)}{3} \rceil$. Let us see how to compute a tree-decomposition of length at most $\lceil \frac{is(G)}{2} \rceil$. Intuitively, every bag will consist of a subgraph of an isometric cycle, and so, for every x and y in a same bag, they will belong to an isometric cycle C and $d_G(x, y) = d_C(x, y) \leq |C|/2 \leq \lfloor \frac{is(G)}{2} \rfloor$. Let us consider an increasing nested ear decomposition \mathcal{E} starting with a maximal isometric cycle E_0 for G (it exists and can be computed in quadratic time by Lemma 2). Let us build the decomposition as follows. Start with a bag containing E_0 . Then, for every $1 \leq i \leq p$, let us connect a bag consisting of E_i to the bag containing E_{j_i} where $0 \leq j_i \leq i \leq p$ and j_i is the minimum index such that E_{j_i} contains a_i and b_i . Recall that G_i is the subgraph induced by E_0, \dots, E_i . Since \mathcal{E} is an increasing nested ear decomposition, $d_{G_{i-1}}(a_i, b_i) \leq |E_i|$ for every $1 \leq i \leq p$ and therefore $V(E_i) \cup P_{G_{i-1}}(a_i, b_i)$ induces an isometric cycle (recall that $P_{G_{i-1}}(a_i, b_i)$ is any shortest a_i, b_i -path in G_{i-1}). Therefore, the length of the tree-decomposition is at most $\lfloor \frac{is(G)}{2} \rfloor \leq \lfloor \lceil \frac{is(G)}{3} \rceil \cdot \frac{3}{2} \rfloor \leq tl(G) \cdot \frac{3}{2}$. ■

5 Characterization of series-parallel graphs with treelength 2

Before stating our main theorem, a last ingredient is required, namely the *Dumbo* graphs. A *Dumbo* graph is any graph built as follows (see Figure 9). Start with a cycle $C_0 = (v_0, \dots, v_5)$

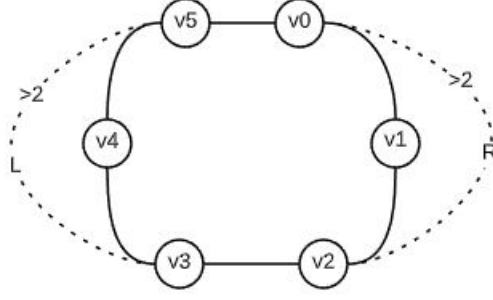

Figure 9: a Dumbo Graph of length 2

of length 6, and add a path R of length (number of edges) at least 3 between v_0 and v_2 and a path L of length at least 3 between v_3 and v_5 . Note that a Dumbo graph is series-parallel.

This section is devoted to prove the following theorem which highly relies on the ear-decompositions of series-parallel graphs.

Theorem 3 *For any series-parallel graph G , $tl(G) \leq 2$ if and only if $is(G) \leq 6$ and G does not contain a Dumbo graph as isometric subgraph.*

Moreover, there is a polynomial algorithm that either computes a tree-decomposition of length at most 2 of G or exhibits a certificate that $tl(G) > 2$ (a large isometric cycle or an isometric Dumbo subgraph).

The “if” part follows from Lemma 1 ($tl(G) \geq \lceil \frac{is(G)}{3} \rceil$) and from the following lemma.

Lemma 4 *If a series-parallel graph G contains a Dumbo graph as isometric subgraph, then $tl(G) > 2$.*

Proof. Let $G = (V, E)$ be any series-parallel graph containing a Dumbo graph $D = (C_0, R, L)$ as isometric subgraph. For purpose of contradiction, let us assume that G admits a tree-decomposition (T, \mathcal{X}) of length at most 2. By Lemma 5, there must be a bag $X \in \mathcal{X}$ containing $\{v_0, v_2, v_4\}$ or $\{v_1, v_3, v_5\}$. By symmetry, let us assume that $\{v_0, v_2, v_4\} \subseteq X$. Let z be a vertex of $L \setminus \{v_5, v_3\}$ such that $|dist(z, v_5) - dist(z, v_3)| \leq 1$. Note that $dist(z, v_5), dist(z, v_3) \geq 1$ and $\max\{dist(z, v_5), dist(z, v_3)\} \geq 2$. Moreover, because G is series-parallel, every path from z to v_0, v_2 or v_4 goes through v_3 or v_5 (otherwise, there would be a K_4 minor). Note also that no bag contains $\{v_0, v_2, v_4, z\}$ since z is at distance at least 3 from some of v_0, v_2, v_4 .

Let Y be a bag containing z that is closest to X , and let X' be the bag containing v_0, v_2, v_4 that is closest to Y . Let $Z' \notin \{X', Y\}$ be the neighbor of X' on the path between X' and Y in T and let $Z = X' \cap Z'$ (or $Z = X' \cap Y$ if $X'Y \in E(T)$). Note that $z \notin Z$. Note also that at least one of v_0, v_2 and v_4 is not in Z (otherwise, it would contradict either the fact that X' is closest to Y or that no bag contains all v_0, v_2, v_4 and z). Let $W = \{v_0, v_2, v_4\} \setminus Z$. By the properties of tree-decomposition, Z must separate every $w \in W$ from z . There are several cases to be considered depending on which vertex of v_0, v_2 and v_4 are not in Z :

- If at least v_2 belongs to Z , then $W \subseteq \{v_0, v_4\}$. Hence, there must be u in the z - v_5 subpath of L that is in Z if v_0 or v_4 are in W (i.e in every case) and there must be v in the z - v_3 subpath of L that is in Z if v_4 is in W . Since $z \notin Z$, $u \neq z$ and $d(u, v_3) \geq 2$ and then $d(u, v_2) \geq 3$. Therefore, there is no tree-decomposition of length 2 with at least v_2 in Z .

- If at least v_0 belongs to Z , then $W \subseteq \{v_2, v_4\}$. Hence, there must be v in the z - v_3 subpath of L that is in Z if v_2 or v_4 are in W (i.e in every case) and there must be u in the z - v_5 subpath of L that is in Z if v_4 is in W . Since $z \notin Z$, $v \neq z$ and $d(v, v_5) \geq 2$ and then $d(v, v_0) \geq 3$. Therefore, there is no tree-decomposition of length 2 with at least v_0 in Z .
- Finally, if at least v_4 belongs to Z , then $W \subseteq \{v_0, v_2\}$. Hence, there must be u in the z - v_5 subpath of L that is in Z if v_0 is in W and there must be v in the z - v_3 subpath of L that is in Z if v_2 is in W . Since $z \notin Z$, $v \neq z$, $u \neq z$, $d(u, v_3) \geq 2$ and $d(v, v_5) \geq 2$ and then $d(v, v_0) \geq 3$ and $d(u, v_2) \geq 3$. Therefore, there is no tree-decomposition of length 2 with at least v_4 in Z .

■

The “only if” part follows from Lemma 7 whose proof describes the algorithm. Lemma 5 and Lemma 6 will be used in the proof of Lemma 7 to deal with the case of ears of length 2.

Given a graph G and a tree-decomposition (T, \mathcal{X}) of G . Let S be any subtree of T . Let G_S denote the subgraph of G induced by $\{v \in X_t \mid t \in S\}$.

Lemma 5 *Let G be any graph and C be any isometric cycle of length ℓ . In any tree-decomposition (T, \mathcal{X}) of G with length at most $\lceil \frac{\ell}{3} \rceil$, there exists a bag $X \in \mathcal{X}$ containing three vertices $a, b, c \in V(C)$ such that $\lceil \frac{\ell}{3} \rceil = \text{dist}(a, b) \geq \text{dist}(a, c) \geq \lfloor \frac{\ell}{3} \rfloor$ and $\text{dist}(a, c) \geq \text{dist}(c, b) \geq \lfloor \frac{\ell}{3} \rfloor - 1$.*

Proof. Let (T, \mathcal{X}) be any tree-decomposition of G of length at most $\lceil \frac{\ell}{3} \rceil$. Note that, by Theorem 1, (T, \mathcal{X}) has length exactly $\lceil \frac{\ell}{3} \rceil$. Since every edge must appear in some bag, there must be bags containing at least two vertices of C . For every $X \in \mathcal{X}$ with $|X \cap V(C)| \geq 2$, let $d(X) = \max_{u, v \in X \cap V(C)} \text{dist}(u, v)$. Let X be a bag maximizing $d(X)$ and $a, b \in X \cap V(C)$ with $\text{dist}(a, b) = d(X)$. Since $d(X) \leq \text{length}(X)$, then $\text{dist}(a, b) \leq \lceil \frac{\ell}{3} \rceil$. Let P be the path of C between a and b of length $\ell - \text{dist}(a, b)$, and let $c \in V(P)$ such that $0 \leq \text{dist}(a, c) - \text{dist}(b, c) \leq 1$. By definition, $\text{dist}(a, c), \text{dist}(b, c) \geq \lfloor \frac{\ell}{3} \rfloor$. If $c \in X$, then a, b, c and X satisfy the statement with $\lceil \frac{\ell}{3} \rceil = \text{dist}(a, b) \geq \text{dist}(a, c) \geq \text{dist}(b, c) = \lfloor \frac{\ell}{3} \rfloor$.

For purpose of contradiction, let us assume that no bag contains a, b and c . Let Y be a bag containing c (exists by the properties of a tree-decomposition) that is closest to X in T and let X' be a bag containing a and b that is closest to Y . Let $Z \notin \{X', Y\}$ be any bag on the path between X' and Y in T (or $Z = X' \cap Y$ if $X'Y \in E(T)$). Note that $c \notin Z$. Note also that at least one of a and b is not in Z (otherwise, it would contradict either the fact that X' is closest to Y or that no bag contains all a, b, c). Without loss of generality, let us assume that $a \notin Z$. By the properties of tree-decomposition, Z must separate a and c . Hence, there is a vertex u between a and c in P that belongs to Z . If $u \in X'$, then a, b and u are the required vertices. Indeed, by the maximality of $\text{dist}(a, b)$, $\text{dist}(a, b) \geq \text{dist}(u, b)$ and so the shortest path between u and b in C goes through c . Hence $\text{dist}(u, b) > \text{dist}(b, c) \geq \lfloor \frac{\ell}{3} \rfloor$ and so $\text{dist}(u, b) = \text{dist}(a, b) = \lceil \frac{\ell}{3} \rceil$ and $\text{dist}(u, a) = \lfloor \frac{\ell}{3} \rfloor - 1$.

Let us now assume that $u \notin X'$. Let e be the edge incident to X' in the path between X' and Y in T . Let T_1 be the component of $T \setminus e$ containing X' , and let T_2 be the other component (containing Y). Let $P' = (a = u_0, \dots, u_k = c)$ be the subpath from a to c in P (note that $u \in P'$). Let $0 \leq i \leq k$ be the smallest integer such that $u_i \in G_{T_1} \setminus G_{T_2}$ and $u_{i+1} \in G_{T_2} \setminus G_{T_1}$. Such an integer exists since $a \in G_{T_1} \setminus G_{T_2}$ and $u \in G_{T_2} \setminus G_{T_1}$. This implies that the edge $u_i u_{i+1}$ cannot appear in any bag, a contradiction.

■

Some notations are still needed. Let G be a 2-connected series-parallel graph with a nested increasing ear decomposition $\mathcal{E} = (E_i)_{0 \leq i \leq p}$ such that E_0 is a largest isometric cycle of G . Recall

that a_i and b_i denote the endpoints of E_i ($a_i, b_i \in V(G_{i-1})$). Let $\ell_i = |E_i|$ and $d_i = d_{G_{i-1}}(a_i, b_i)$. Since \mathcal{E} is increasing, $d_i \leq \ell_i$ for all $1 \leq i \leq p$. Finally, for any subgraph H of G induced by $\bigcup_{i' \leq j \leq i} V(E_{j'})$, let $\text{Att}(H) \subseteq V(H)$ be the set of vertices of H that are the attachment vertices (a_k and b_k) of some ear E_k with $k > i$.

Lemma 6 *Let G be any 2-connected series-parallel graph without clique-separator, with an increasing nested ear decomposition $\mathcal{E} = (E_i)_{0 \leq i \leq p}$. Let (T', \mathcal{X}') be a tree-decomposition, with length at least 2, of the subgraph G_j of G induced by E_0, \dots, E_j and let E_i be such that $1 \leq j_i \leq j < i \leq p$ and $|E_i| = 2$. Then, there exists a tree-decomposition (T, \mathcal{X}) of $G_j \cup E_i$ with same length and such that, for every $B' \in \mathcal{X}'$, there exists $B \in \mathcal{X}$ such that $B' \subseteq B$.*

Proof. Note that by hypothesis, both endpoints of E_i belong to G' since they belong to E_{j_i} . Let us first suppose that the endpoints of E_i are in a same bag B of (T', \mathcal{X}') . Then, the tree-decomposition obtained from (T', \mathcal{X}') by adding a bag $V(E_i)$ adjacent to B satisfies the statement of the Lemma.

Let us now consider the case where no bag of (T', \mathcal{X}') contains the endpoints a_i and b_i of E_i . Let $X \in \mathcal{X}'$ and $Y \in \mathcal{X}'$ be such that $a_i \in X$, $b_i \in Y$ and the distance in T between two such bags is minimum.

Note that, because G has no edge-separator and because the ears are added in increasing order (i.e. $2 \leq d_i \leq \ell_i = 2$), a_i and b_i must have common neighbors in G' . Note also that, because G is series-parallel (in particular, the ears are nested) without clique separator, then every common neighbor w of a_i and b_i satisfies $N(w) = \{a_i, b_i\}$.

By the tree-decomposition properties, every bag W on the X - Y path in T' must separate $X \setminus Y$ from $Y \setminus X$. In particular, $N_{G'}(a_i) \cap N_{G'}(b_i) \subseteq W$. Similarly, $N_{G'}(a_i) \cap N_{G'}(b_i) \subseteq X$ and $N_{G'}(a_i) \cap N_{G'}(b_i) \subseteq Y$. Let v be the common neighbor of a_i and b_i in E_i . Then, adding v to every bag W on the X - Y path in T' (including X and Y) gives the desired decomposition. In particular, for every $v' \in W$, $\text{dist}_G(v', w) = \text{dist}_G(v', v)$ where w is any vertex in $N_{G'}(a_i) \cap N_{G'}(b_i)$, and so the obtained tree-decomposition has same length as (T', \mathcal{X}') . ■

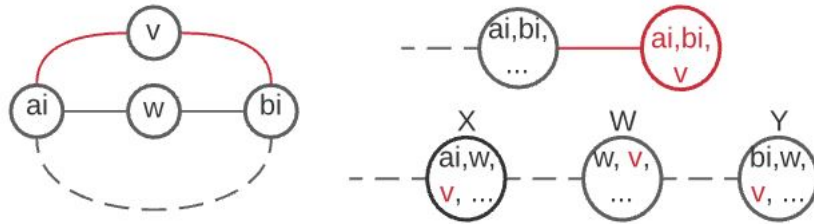

Figure 10: a graph $G_j \cup E_i$ with $\ell_i = 2$ (left) and the update of a tree-decomposition of G_j to a tree-decomposition of $G_j \cup E_i$ when the endpoints of E_i are contained in a same bag (right-top) or when they are in different bags (right-bottom) from Lemma 6

Lemma 7 *Let G be any (simple) prime series-parallel graph and with $is(G) \leq 6$. If G does not contain a Dumbo graph as isometric subgraph, then $tl(G) \leq 2$.*

Proof. Let us assume that G is not a chordal graph in which case the result is trivial (recall that $tl(G) = 1$ if and only if G is chordal, which can be decided in linear time). Hence, we may assume that $tl(G) \geq 2$.

Let G be any series-parallel graph without clique-separator, with $is(G) \leq 6$, and with no Dumbo graph as isometric subgraph. Let $\mathcal{E} = (E_i)_{0 \leq i \leq p}$ be an increasing nested ear-decomposition of G with E_0 being a largest isometric cycle. Note that \mathcal{E} contains no ear of length one since G is simple, series-parallel and prime .

We will build a sequence $\mathcal{E}_1 \subset \mathcal{E}_2 \subset \dots \subset \mathcal{E}_{p'} = \mathcal{E}$ such that $E_0 \in \mathcal{E}_1$ and for every $1 \leq i \leq p'$,

1. $G^i = G[\bigcup_{E \in \mathcal{E}_i} V(E)]$ is an isometric series-parallel subgraph of G with \mathcal{E}_i as ear-decomposition;
2. There are no ears of length two is attached to G^i , i.e., every ear of \mathcal{E} not yet in G^i with both endpoints in G^i has length at least 3;
3. G^i admits a tree-decomposition (T^i, \mathcal{X}^i) of length 2, and
4. For every ear $E_j \in \mathcal{E} \setminus \mathcal{E}_i$ attached to G^i , there exists $t \in V(T^i)$ such that $\{a_j, b_j\} \subseteq X_t^i \in \mathcal{X}^i$, i.e., every ear not yet in G^i with both endpoints in G^i (so with length at least 3) has both its endpoints in some bag of (T^i, \mathcal{X}^i) .

The proof is by induction on $1 \leq i \leq p'$. The base case consists in building \mathcal{E}_1 . There are several cases depending of the size of E_0 , $4 \leq \ell_0 \leq 6$ ($|E_0| = \ell_0 > 3$ since G is not chordal). Let us first build \mathcal{E}_1 . There are several cases depending of the size of E_0 .

- If $E_0 = (a, b, c, d)$ has length 4 (it cannot have length 3 since G is not chordal), recall that since G is series-parallel, the ears are nested, there cannot be an ear attached to a and c and an ear attached to b and d . Indeed, since G has no clique separator, no ear can be attached to two adjacent vertices and every ear attached to E_0 has a length 2 (else $is(G) > 4$). Then, up to symmetries, $Att(E_0) = \{a, c\}$ (if $Att(E_0) = \emptyset$, then $G = E_0$ and the result is trivial) (see Figure 11). Let \mathcal{E}_1 consist of E_0 and the set of all ears of length

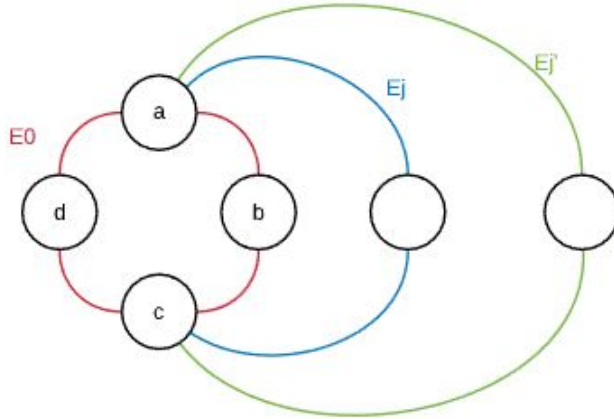

Figure 11: case where E_0 has length 4

two attached to a and c . Then, (T^1, \mathcal{X}^1) is the tree-decomposition with one "central" bag $\{a, b, c, d\}$ with one neighbouring bag E_j for every ear $E_j \in \mathcal{E}_1 \setminus \{E_0\}$ (see Figure 12). (T^1, \mathcal{X}^1) is clearly a tree-decomposition of G^1 with length 2. Finally, because the ears are nested and there are no clique separators, every ear in $\mathcal{E} \setminus \mathcal{E}_1$ with attachment vertices in G^1 must have a and c as attachment vertices. If such an ear in $\mathcal{E} \setminus \mathcal{E}_1$ exists, it must have length at least 3 which would contradict the fact that E_0 is a largest isometric cycle. Hence, no such ear exists and $G^1 = G$.

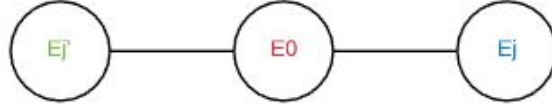

Figure 12: Tree-decomposition of G when E_0 has length 4

- If $E_0 = (a, b, c, d, e)$ has length 5 then, up to symmetries, $Att(E_0) \subseteq \{a, c, d\}$ (if $Att(E_0) = \emptyset$, then $G = E_0$ and the result is trivial). More precisely, ears can be attached to a and c or to a and d . Indeed, since G has no clique separator, no ear can be attached to two adjacent vertices (see Figure 13). Let \mathcal{E}_1 consist of E_0 and the set of all ears of length

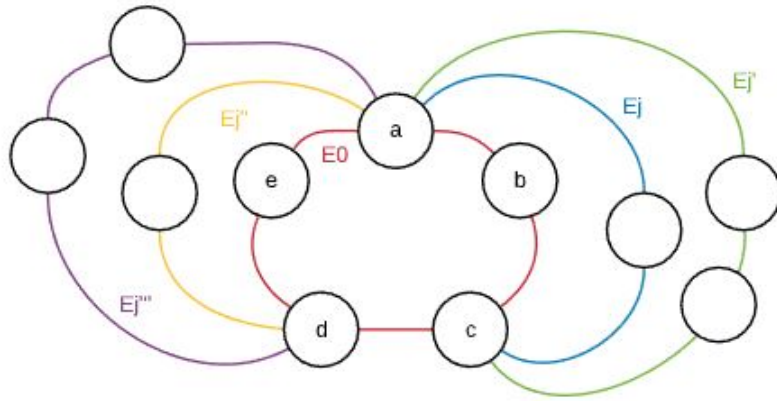

Figure 13: case where E_0 has length 5 (E_j and E_j'' are contained in a bag since they have length 2. E_j' and E_j''' are not contained in a bag since they have length 3)

two attached to E_0 . Then, (T^1, \mathcal{X}^1) is the tree-decomposition with one "central" bag $\{a, b, c, d, e\}$ with one neighbouring bag E_j for every ear $E_j \in \mathcal{E}_1 \setminus \{E_0\}$ (see Figure 14). (T^1, \mathcal{X}^1) is clearly a tree-decomposition of G^1 with length 2. Finally, every ear in $\mathcal{E} \setminus \mathcal{E}_1$ attached to G^1 has its attachment vertices in E_0 because G is series-parallel and so, the ears are nested. More precisely, otherwise, since an ear cannot have adjacent attachment vertices (no clique separator), there would be an ear $E_j \in \mathcal{E} \setminus \mathcal{E}_1$ and one ear $E_k \in \mathcal{E}_1 \setminus \{E_0\}$ (w.l.o.g., say with attachment vertices a and c) with $a_j \in E_k \setminus \{a, c\}$ and $b_j \notin \{a, c\}$. This would imply that G contains a K_4 as minor, a contradiction.

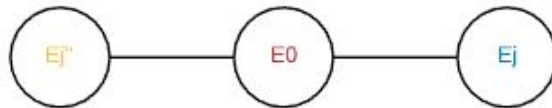

Figure 14: Tree-decomposition of \mathcal{E}_1 when E_0 has length 5 (E_j and E_j'' are contained in a bag since they have length 2. E_j' and E_j''' are not contained in a bag since they have length 3)

- Then, let us consider the case when $E_0 = (a, b, c, d, e, f)$ has length 6. If there is an ear attached to two vertices at distance 3, note that every such ear has length exactly 3 since E_0 is a largest isometric cycle. Moreover, all such ears have the same attachment vertices since the ears are nested (otherwise, there would be a K_4 minor). W.l.o.g., let a and d be

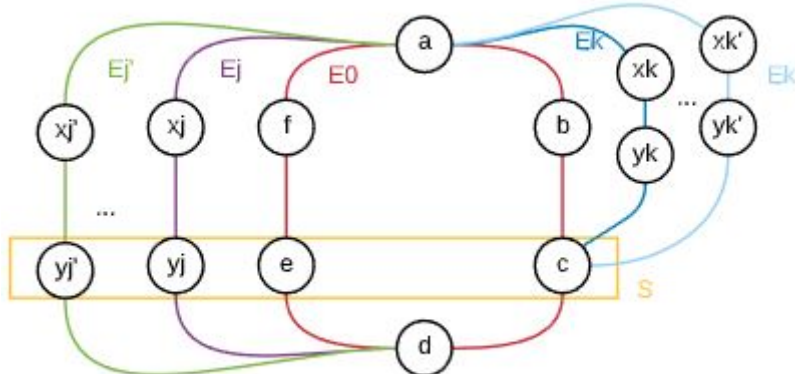

Figure 15: case where E_0 has length 6

the attachment vertices of all (if any) ears attached to vertices at distance 3 in E_0 . Let \mathcal{E}'_1 consists of E_0 and all ears $E_j = (a_j = a, x_j, y_j, b_j = d)$ attached to a and d . Since G has no Dumbo graph as isometric subgraph, there are no two ears $X, Y \in \mathcal{E} \setminus \mathcal{E}'_1$ of length at least three such that X is attached to a and c (resp., e) or to a and y_j for some ear $E_j \in \mathcal{E}'_1$ and Y is attached to d and f (resp. b) or to d and x_k for some ear $E_k \in \mathcal{E}'_1$. Therefore, w.l.o.g., all ears of length at least 3 that are attached to $G' = G[\bigcup_{E \in \mathcal{E}'_1} V(E)]$ have a and some vertex in $B = \{c, e\} \cup \bigcup_{E_j \in \mathcal{E}'_1} \{y_j\}$ as attachment vertices (see Figure 15). Let (T', \mathcal{X}') be the tree-decomposition with one “central” bag $C = B \cup \{a\}$ with one neighbouring bag $\{a, x_j, y_j\}$ for every ear $E_j \in \mathcal{E}'_1 \setminus \{E_0\}$, one neighbouring bag $\{a, b, c\}$, one neighbouring bag $\{a, f, e\}$, and one neighbouring bag $\{d\} \cup B$. Then, (T', \mathcal{X}') is clearly a tree-decomposition of G' of length 2 such that all ears of length at least 3 attached to G' have their attachment vertices in C . Finally, let F be the set of all ears of length 2 attached to G' . Let $\mathcal{E}_1 = \mathcal{E}'_1 \cup F$. By Lemma 6, from (T', \mathcal{X}') , we can obtain a tree-decomposition (T^1, \mathcal{X}^1) of G^1 of length 2 such that every bag in \mathcal{X}' is contained in some bag of \mathcal{X}^1 (see Figure 16).

Finally, since G has no clique separator and is series-parallel (in particular the ears are nested), every ear attached to G^1 must have both its attachment vertices in a same bag of (T^1, \mathcal{X}^1) , and must have length at least 3 (since otherwise it would have been included in \mathcal{E}_1).

Now, let's prove by induction on $1 \leq i < p'$ that we can build an ear decomposition \mathcal{E}_{i+1} from \mathcal{E}_i with all the desired properties. Let E_j be any shortest ear not in \mathcal{E}_i with attachment vertices $\{a_j, b_j\} \in V(G^i)$. Because G has no clique separator and, by the induction hypothesis, G^i has a tree-decomposition (T^i, \mathcal{X}^i) of length 2 with a bag containing a_j and b_j , note that $d_j = \text{dist}_G(a_j, b_j) = \text{dist}_{G^i}(a_j, b_j) = 2$. Moreover, because $is(G) = 6$ and that there is no ear of length two attached to G^i , the length ℓ_j of E_j is such that $3 \leq \ell_j \leq 4$. There are two cases depending of the length of E_j .

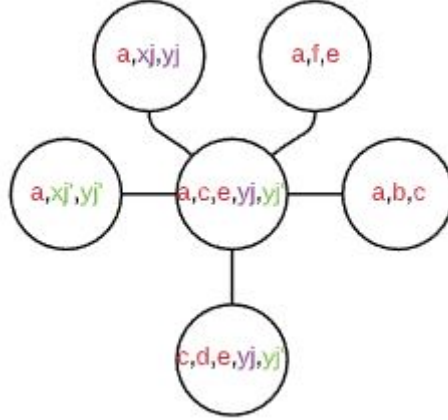

Figure 16: Tree-decomposition of \mathcal{E}_1 when E_0 has length 6

- If $E_j = (a_j, x, y, b_j)$ has length 3, then up to symmetries $Att(G^i \cup E_j) \cap V(E_j) \subseteq \{a_j, y, b_j\}$. Indeed, since G has no clique separator, no ear can be attached to two adjacent vertices and since all ears of \mathcal{E} are nested, there isn't an ear attached to a_j and y and another one to x and b_j , or an ear attached to a vertex of $V(E_j) \setminus \{a_j, b_j\}$ and to a vertex of $V(G_i) \setminus \{a_j, b_j\}$ (see Figure 17). Let \mathcal{E}'_{i+1} consist of \mathcal{E}_i and E_j . Let $G' = G[\bigcup_{E \in \mathcal{E}'_{i+1}} V(E)]$ and (T', \mathcal{X}') be the tree-decomposition build from (T^i, \mathcal{X}^i) with a bag $B = \{a_j, x, y, b_j\}$ connected to a bag of (T^i, \mathcal{X}^i) containing a_j and b_j . Then, (T', \mathcal{X}') is clearly a tree-decomposition of G' of length 2. Finally, let F be the set of all ears of length 2 attached to G' (note that, because of the induction hypothesis and the fact that the initial ear decomposition is increasing, all such ears are attached to a_j and y). Let $\mathcal{E}_{i+1} = \mathcal{E}'_{i+1} \cup F$. By Lemma 6, from (T', \mathcal{X}') , we can obtain a tree-decomposition $(T^{i+1}, \mathcal{X}^{i+1})$ of G^{i+1} of length 2 such that every bag of \mathcal{X}' is contained in some bag of \mathcal{X}^{i+1} (see Figure 17). Clearly if there is an ear attached to the only middle vertex of an ear E_f of F then by definition of a nested ear decomposition, it's second endpoint is a vertex in E_f which contradicts the fact that G has no clique-separator. We can deduce that for every E_m attached to G^{i+1} there exists $t \in V(T^{i+1})$ such that $\{a_m, b_m\} \subseteq X_t^{i+1}$.

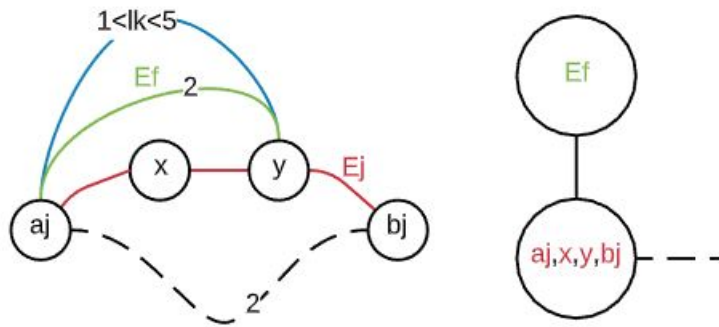

Figure 17: case where E_j has length 3

- Now, let us assume that $E_j = (a_j, x, y, z, b_j)$ has length 4. There are several cases depending of the vertices of E_j that are attachment vertices for other ears E_l in $\mathcal{E} \setminus (\mathcal{E}_i \cup \{E_j\})$ attached to E_j . Because G has no clique separator and \mathcal{E} is an increasing nested ear decomposition, we have these following possibilities up to symmetries.

- If $\text{Att}(E_j) \subseteq \{a_j, y, b_j\}$, (see Figure 18), then let \mathcal{E}'_{i+1} consist of \mathcal{E}_i and E_j . Let (T', \mathcal{X}') be the tree-decomposition of $G' = G[\bigcup_{E \in \mathcal{E}'_{i+1}} V(E)]$ built from (T^i, \mathcal{X}^i) as follows. Let B be any bag of (T^i, \mathcal{X}^i) containing both a_j and b_j (exists by the induction hypothesis). Let us add the bag $\{a_j, y, b_j\}$ adjacent to B and to the bags $\{a_j, x, y\}$ and $\{y, z, b_j\}$. Since (T^i, \mathcal{X}^i) is a tree-decomposition of G^i of length 2, then (T', \mathcal{X}') is also a tree-decomposition of G' of length 2. Let F be the set of ears of length 2 attached to E_j and let \mathcal{E}_{i+1} consist of \mathcal{E}'_{i+1} and F . By lemma 6, we can obtain from (T', \mathcal{X}') a tree-decomposition $(T^{i+1}, \mathcal{X}^{i+1})$ of length 2 of G^{i+1} . Finally, $(T^{i+1}, \mathcal{X}^{i+1})$ satisfies the desired properties (in particular because G has no edge separator, every ear attached to G^{i+1} has its attachment vertices in a bag of $(T^{i+1}, \mathcal{X}^{i+1})$).

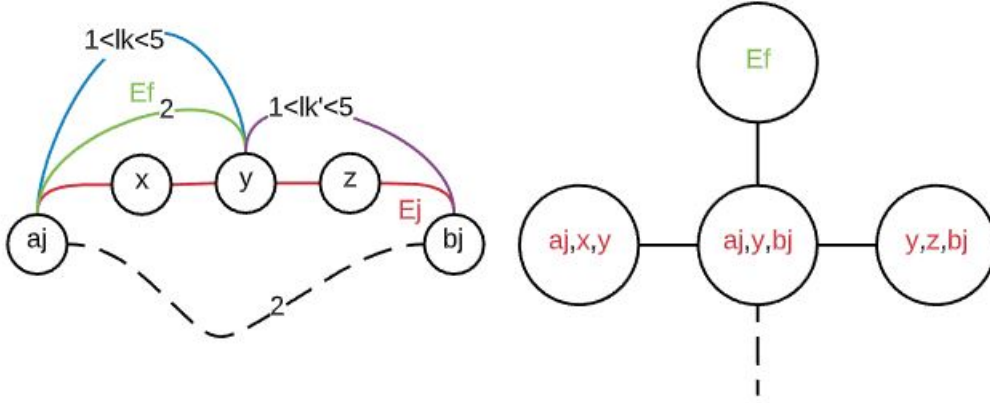

Figure 18: case where E_j has length 4 and $\text{Att}(E_j) \subseteq \{a_j, y, b_j\}$

- Now, let us assume, up to symmetry, that there exists an ear E' attached to a_j and z . Note that such an ear has length exactly 3 since \mathcal{E} is an increasing nested ear decomposition and no isometric cycle has length more than 6. Let \mathcal{E}' be the set of all ears $E_{j'} = (a_j = a_{j'}, x_{j'}, y_{j'}, b_{j'} = z) \notin \mathcal{E}_i$ of length 3 attached to a_j and z (in particular, E' is such an ear), and let \mathcal{E}'_{i+1} consist of $\mathcal{E}_i \cup E_j \cup \mathcal{E}'$. (see Figure 19). Let us first show that no ear $E_q \in \mathcal{E} \setminus \mathcal{E}'_{i+1}$ of length at least 3 is attached to $x_{j'}$ and $b_{j'}$ for some j' such that $E_{j'} \in \mathcal{E}'$ (resp. to x and z). For purpose of contradiction, let us assume that such an ear E_q exists. Recall that, by the induction hypothesis, a_j and b_j must belong to a same bag of (T^i, \mathcal{X}^i) of length 2 and that, because there is no clique separator, $a_j, b_j \notin E(G)$. Hence, $\text{dist}_G(a_j, b_j) = \text{dist}_{G^i}(a_j, b_j) = 2$. Let E_ℓ be the first (i.e., with minimum ℓ) ear of G^i containing both a_j and b_j (such an ear must exist since E_j can only be attached to the vertices of some previous ear).
 - * If $E_\ell = E_0$, then, the subgraph induced by $V(E_0) \cup V(E_{j'}) \cup V(E_q)$ (resp. $V(E_0) \cup V(E_j) \cup V(E_q)$) is an isometric Dumbo graph, a contradiction.
 - * Otherwise (if $\ell \neq 0$), let a_ℓ and b_ℓ be the end points of E_ℓ , and let G^* be the subgraph induced by the vertices of the ears in $\{E_m \in \mathcal{E}^i \mid m < \ell\}$. Note that

G^* is an isometric subgraph of G^i . W.l.o.g., $a_\ell \notin \{a_j, b_j\}$ (otherwise this would contradict that E_ℓ is the first ear in which both a_j and b_j appear). Let P be any shortest a_ℓ - b_ℓ path in G^* . Since a_ℓ and b_ℓ are not adjacent (otherwise there would be an edge separator in G), P has length at least 2. Then, the subgraph induced by $V(P) \cup V(E_\ell) \cup V(E_{j'}) \cup V(E_q)$ (resp. $V(P) \cup V(E_\ell) \cup V(E_j) \cup V(E_q)$) is an isometric Dumbo graph, a contradiction.

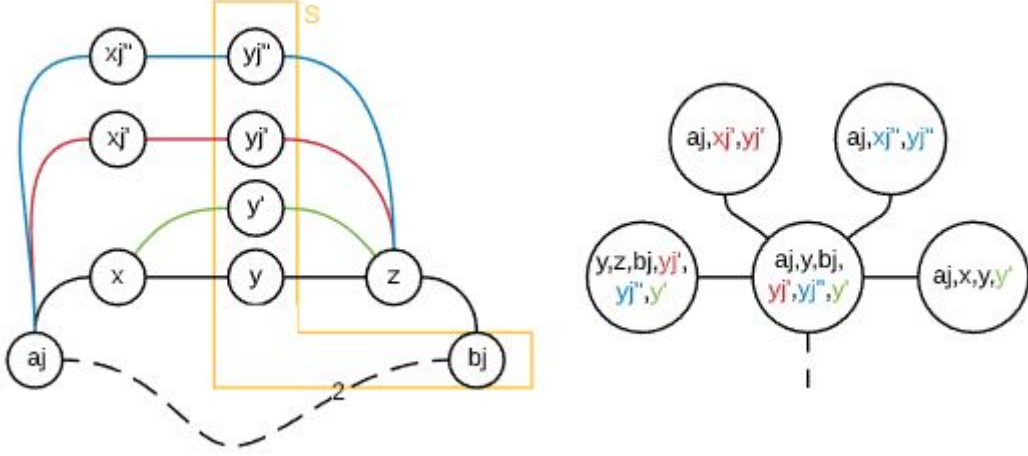

Figure 19: case where E_j has length 4 and there is at least one ear attached to a_j and z

Let B be any bag of (T^i, \mathcal{X}^i) containing both a_j and b_j (exists by the induction hypothesis). Let $B' = \{a_j, b_j, y\} \cup_{j', E_{j'} \in \mathcal{E}'} \{y_{j'}\}$, let $B_{j'} = \{a_j, x_{j'}, y_{j'}\}$ for all j' such that $E_{j'} \in \mathcal{E}'$, let $B'' = \{b_j, z, y\} \cup_{j', E_{j'} \in \mathcal{E}'} \{y_{j'}\}$, and let $B_j = \{a_j, x, y\}$.

Let (T', \mathcal{X}') be the tree-decomposition of $G' = G[\cup_{E \in \mathcal{E}'_{i+1}} V(E)]$ built from (T^i, \mathcal{X}^i) by adding the bag B' adjacent to B , to B'' , to B_j and to $B_{j'}$ for all j' such that $E_{j'} \in \mathcal{E}'$. It can be shown that (T', \mathcal{X}') is a tree-decomposition of G' , with length 2 and such that every ear of length at least 3 attached to G' has both its attachment vertices in some bag of (T', \mathcal{X}') . Let F be the set of ears of length 2 attached to some ear in $\mathcal{E}' \cup E_j$ and let \mathcal{E}_{i+1} consist of \mathcal{E}'_{i+1} union F . By lemma 6, we can obtain from (T', \mathcal{X}') a tree-decomposition $(T^{i+1}, \mathcal{X}^{i+1})$ of length 2 of G^{i+1} .

Finally, $(T^{i+1}, \mathcal{X}^{i+1})$ satisfies the desired properties (in particular because G has no edge separator, every ear attached to G^{i+1} has its attachment vertices in a bag of $(T^{i+1}, \mathcal{X}^{i+1})$). ■

6 Further work

This work presents the first characterization of the treelength of a class of graphs in terms of forbidden isometric subgraphs. In particular, we show that deciding if the treelength of a series-parallel graph is at most 2 can be done in polynomial time while this problem is NP-complete in general graphs. Our approach seems difficult to generalize to larger values of the treelength. Indeed, for treelength 3, we have already identified about 20 infinite families of forbidden isometric subgraphs. All these families are slight variations of the Dumbo graphs but

we still do not know how to describe them in a synthetic way. The next step is then to find a polynomial-time algorithm that computes the treelength of series-parallel graphs (or to prove that it is an NP-hard problem). The main goal is to further investigate the computational complexity of computing the treelength (or even the treewidth) of planar graphs. Designing better approximation algorithms for general or planar or series-parallel graphs is also an interesting open problem.

References

- [1] S. Arnborg, D. G. Corneil, and A. Proskurowski. Complexity of finding embeddings in a k -tree. *SIAM J. of Discrete Mathematics*, 8(2):277–284, 1987.
- [2] R. Belmonte, F. V. Fomin, P. A. Golovach, and M. S. Ramanujan. Metric dimension of bounded tree-length graphs. *SIAM J. Discret. Math.*, 31(2):1217–1243, 2017.
- [3] H. L. Bodlaender, M. Cygan, S. Kratsch, and J. Nederlof. Deterministic single exponential time algorithms for connectivity problems parameterized by treewidth. *Inf. Comput.*, 243:86–111, 2015.
- [4] H. L. Bodlaender, P. Grønås Drange, M. S. Dregi, F. V. Fomin, D. Lokshtanov, and M. Pilipczuk. A $c^k n$ 5-approximation algorithm for treewidth. *SIAM J. Comput.*, 45(2):317–378, 2016.
- [5] H. L. Bodlaender, F. V. Fomin, D. Lokshtanov, E. Penninkx, S. Saurabh, and D. M. Thilikos. (meta) kernelization. *J. ACM*, 63(5):44:1–44:69, 2016.
- [6] H. L. Bodlaender and T. Kloks. Efficient and constructive algorithms for the pathwidth and treewidth of graphs. *J. Algorithms*, 21(2):358–402, 1996.
- [7] D. Coudert, G. Ducoffe, and N. Nisse. To Approximate Treewidth, Use Treelength! *SIAM J. on Disc. Maths.*, 30(3):13, 2016.
- [8] B. Courcelle and M. Mosbah. Monadic second-order evaluations on tree-decomposable graphs. *Theor. Comput. Sci.*, 109(1&2):49–82, 1993.
- [9] M. Cygan, F. V. Fomin, L. Kowalik, D. Lokshtanov, D. Marx, Ma. Pilipczuk, Mi. Pilipczuk, and S. Saurabh. *Parameterized Algorithms*. Springer, 2015.
- [10] E. D. Demaine and M. Hajiaghayi. The bidimensionality theory and its algorithmic applications. *Comput. J.*, 51(3):292–302, 2008.
- [11] Y. Dieng and C. Gavaille. On the tree-width of planar graphs. *Electron. Notes Discret. Math.*, 34:593–596, 2009.
- [12] R. Diestel. *Graph Theory, 4th Edition*, volume 173 of *Graduate texts in mathematics*. Springer, 2012.
- [13] Y. Dourisboure and C. Gavaille. Tree-decompositions with bags of small diameter. *Discrete Maths.*, 307(16):2008–2029, 2007.
- [14] F. F. Dragan and E. Köhler. An approximation algorithm for the tree t -spanner problem on unweighted graphs via generalized chordal graphs. *Algorithmica*, 69(4):884–905, 2014.

- [15] G. Ducoffe, S. Legay, and N. Nisse. On the complexity of computing treebreadth. *Algorithmica*, 82(6):1574–1600, 2020.
- [16] D. Eppstein. Parallel recognition of series-parallel graphs. *Inf. Comput.*, 98(1):41–55, May 1992.
- [17] U. Feige, M.T. Hajiaghayi, and J. R. Lee. Improved approximation algorithms for minimum weight vertex separators. *SIAM J. Comput.*, 38:629–657, 2008.
- [18] R. Halin. S-functions for graphs. *Journal of Geometry*, 8:171–186, 1976.
- [19] F. Kammer and T. Tholey. Approximate tree decompositions of planar graphs in linear time. *TCS*, 645:60–90, 2016.
- [20] A. Kosowski, B. Li, N. Nisse, and K. Suchan. k-chordal graphs: From cops and robber to compact routing via treewidth. *Algorithmica*, 72(3):758–777, 2015.
- [21] R. Krauthgamer and J. R. Lee. Algorithms on negatively curved spaces. In *47th Annual IEEE Symposium on Foundations of Computer Science (FOCS 2006), 21-24 October 2006, Berkeley, California, USA, Proceedings*, pages 119–132. IEEE Computer Society, 2006.
- [22] D. Lokshtanov. On the complexity of computing treelength. *Discrete Applied Mathematics*, 158:820–827, 01 2010.
- [23] N. Robertson and P. D. Seymour. Graph minors. ii. algorithmic aspects of tree-width. *J. of Algorithms*, 7(3):309 – 322, 1986.
- [24] P. D. Seymour and R. Thomas. Call routing and the ratcatcher. *Comb.*, 14(2):217–241, 1994.
- [25] J. Valdes, R. E. Tarjan, and E. L. Lawler. The recognition of series parallel digraphs. *SIAM J. Comput.*, 11:298–313, 1982.