



HAL
open science

Privacy Impact on Generalized Nash Equilibrium in Peer-to-Peer Electricity Market

Ilia Shilov, H el ene Le Cadre, Ana BuŐic

► **To cite this version:**

Ilia Shilov, H el ene Le Cadre, Ana BuŐic. Privacy Impact on Generalized Nash Equilibrium in Peer-to-Peer Electricity Market. *Operations Research Letters*, 2021, 49, pp.759-766. 10.1016/j.orl.2021.08.001 . hal-03112775

HAL Id: hal-03112775

<https://inria.hal.science/hal-03112775v1>

Submitted on 17 Jan 2021

HAL is a multi-disciplinary open access archive for the deposit and dissemination of scientific research documents, whether they are published or not. The documents may come from teaching and research institutions in France or abroad, or from public or private research centers.

L'archive ouverte pluridisciplinaire **HAL**, est destin ee au d ep ot et  a la diffusion de documents scientifiques de niveau recherche, publi es ou non,  emanant des  tablissements d'enseignement et de recherche fran ais ou  trangers, des laboratoires publics ou priv es.

Privacy Impact on Generalized Nash Equilibrium in Peer-to-Peer Electricity Market

Ilia Shilov^{a,b,1}, H el ene Le Cadre^b, Ana Basic^a

^aInria Paris, DI ENS, CNRS, PSL University, France

^bVITO/EnergyVille, Thorpark 8310, Genk, Belgium

Abstract

We consider a peer-to-peer electricity market, where agents hold private information that they might not want to share. The problem is modeled as a noncooperative communication game, which takes the form of a Generalized Nash Equilibrium Problem, where the agents determine their randomized reports to share with the other market players, while anticipating the form of the peer-to-peer market equilibrium. In the noncooperative game, each agent decides on the deterministic and random parts of the report, such that (a) the distance between the deterministic part of the report and the truthful private information is bounded and (b) the expectation of the privacy loss random variable is bounded. This allows each agent to change her privacy level. We characterize the equilibrium of the game, prove the uniqueness of the Variational Equilibria and provide a closed form expression of the privacy price. In addition, we provide a closed form expression to measure the impact of the privacy preservation caused by inclusion of random noise and deterministic deviation from agents' true values. Numerical illustrations are presented on the 14-bus IEEE network.

Keywords: Peer-to-peer market, communication game, generalized Nash equilibrium, variational equilibrium, privacy

1. Introduction

The large-scale integration of Distributed Energy Resources (DERs), the increasing share of Renewable Energy Source (RES) - based generators in the energy mix and the more proactive role of prosumers, have led to the evolution of electricity markets from centralized pool-based organizations to decentralized peer-to-peer market designs [20]. Within this peer-to-peer electricity market, agents negotiate their energy procurement seeking to minimize their costs with respect to both individual and coupling constraints, while preserving a certain level of privacy [1]. The problem is modeled as a generalized Nash equilibrium problem (GNEP), parametrized in the privacy level, chosen by the agents.

Information sharing in the peer-to-peer market can improve agents' performance, but also may violate their privacy, leading to the disclosure of agent's private information [10]. This calls for the design of new communication mechanisms that capture the agents' ability to define the information they want to share (their report) with the other market participants, while preserving their privacy [4]. In many applications, this problem is usually addressed by including noise to the reports that the agents subsequently use to compute the market equilibrium [1]. However, this approach does not include the ability of the agents to act strategically on the values of their report. Moreover, the question of the optimal noise distribution is crucial in such a framework [11].

To analyse the market in presence of shared coupling constraints, we employ Generalized Nash Equilibrium (GNE) as

solution concept [16], and a refinement of it, called Variational Equilibria (VE), assuming the shadow variables associated with the shared coupling constraints are aligned among the agents. In our proposed framework, agents compute GNE with respect to the constraints that bound (a) the distance between the deterministic deviation from the true values of the private information and (b) the Kullback-Leibler divergence, that measures the effect of the additive random noise included in the reports.

Game theoretic approaches integrating the prosumers' strategic behaviors in the peer-to-peer trading are considered in [1], [19]. The economic dispatch in energy communities under different structures of communications is analysed in [14], [15]. The impact of privacy on an energy community was analyzed in the literature, e.g. in [1], where the sensitive information and the noise added to agents' reports were considered as exogenous parameters. Using a prediction model, Fioretto et al. provide a privacy-preserving mechanism, to protect the information exchanged between the different market operators while guaranteeing their coordination [4].

The anticipation of the actions of the agents in our model is represented by the common knowledge of the *form of the solution*. This anticipation will be used in strategic behavior framework to compute the prosumers' optimal deviation in their private information reports.

Various definitions of privacy have been introduced in the data science literature [13]. Several information metrics: e.g., mutual information, entropy, Kullback-Leibler divergence, and Fisher information are used to quantify information release [3], [11]. Differential privacy (DP) was recently successfully applied to multi-energy market operations [4] and dynamical systems [11]. DP relies on adding noise to the reports from predetermined distributions. In our model we also use the additive

Email address: ilia.shilov@inria.fr (Ilia Shilov)

¹Corresponding author

noise, but we relax the assumptions of DP mechanism and focus on the prosumers' ability to determine their noise distribution. It is done by bounding the expectation of the *privacy loss random variable* [2], which constitutes exactly the Kullback-Leibler divergence for the introduced privacy-preserving randomized mechanism.

To analyse the market in presence of shared coupling constraints, we employ Generalized Nash Equilibrium (GNE) as solution concept [16], and a refinement of it, called Variational Equilibria (VE) [16, 17]. We focus on a certain properties of the game, such as *aggregative* and *potential* structure. Different algorithms using such properties as strong/strict-monotonicity of the game operator for computing VE using decentralized or semi-decentralized structure for multi-agent equilibrium problems in generalized aggregative games has recently gained high research interest [5], [6].

1.1. Contributions

We relate the notion of privacy preservation resulting from the non-disclosure of the nominal demands and RES-based generations of the prosumers in [1], to the privacy mechanism with the additive Gaussian noise, that allows each agent to control her privacy level. It is done, firstly, by choosing the deterministic value to report to other agents; secondly, by using the random noise added to that value. We quantify the impact of privacy on the prosumers' costs and provide an analytical expression of the market equilibria. In addition, we allow each agent to change her level of privacy and show the existence of the incentives for the prosumers to deviate from their true sensitive parameter values. We rely on the notion of strong monotonicity to prove the existence and uniqueness of the solution to our problem. Using Kullback-Leibler divergence, we measure the cost of privacy, caused by inclusion of the random noise. All the theoretical results are illustrated on the 14-bus IEEE network.

The organization of the rest of this paper is as follows: in Section 2 we first describe the peer-to-peer electricity trading problem in Subsections 2.1 and 2.2, which constitutes a basis for our communication game, that will be defined in Subsection 2.4. In Section 3 we provide the analytical expression of the GNE, prove the uniqueness of the VE of the game and provide an expression for the utility gap, caused by the introduction of the privacy. Theoretical results are illustrated on the 14-bus IEEE network in Section 4.

2. Statement of the problem

2.1. Preliminaries

In distributed control systems there is a usual trade-off between privacy and cost: to obtain a better solution, each agent relies on the information of the other agents in the system, which they might not have incentives to provide.

Consider a single-settlement market for peer-to-peer electricity trading made of a set \mathcal{N} of N agents, each one of them being located in a node of a communication network, that is modeled as a graph $\mathcal{G} := (\mathcal{N}, E)$ where $E \subseteq \mathcal{N} \times \mathcal{N}$ is the set of communication links between the players. Let Ω_n be the

set of nodes, player n wants to trade electricity with. Being the interface node between the local electricity market and at the distribution level and the transmission power network, node 0 can communicate with any other nodes in $\Omega_0 := \mathcal{N} \setminus 0$. The graph \mathcal{G} does not necessarily reflect the distribution power network constraints.

In this paper we focus on the privacy issues that arise after solving the peer-to-peer electricity trading problem, considered in [1].

Each agent n chooses independently her bilateral trades \mathbf{q}_n with agents she wants to trade electricity with, self-generation G_n and flexible demand D_n , in order to minimize her cost function Π_n :

$$\begin{aligned} \Pi_n(D_n, G_n, \mathbf{q}_n) := & \underbrace{1/2 \cdot a_n G_n^2 + b_n G_n + d_n}_{C_n(G_n)} + \\ & + \underbrace{\tilde{a}_n (D_n - D_n^*)^2 - \tilde{b}_n}_{U_n(D_n)} + \underbrace{\sum_{m \in \Omega_n, m \neq n} c_{nm} q_{mn}}_{\tilde{C}_n(\mathbf{q})}, \end{aligned} \quad (1)$$

where $a_n, b_n, d_n, \tilde{a}_n, \tilde{b}_n > 0$ and D_n^* denotes the *nominal demand* of agent n [1]. Thus, the vector of agent n 's decision variables is (D_n, G_n, \mathbf{q}_n) , where $\mathbf{q}_n := (q_{mn})_{m \in \Omega_n}$ is the vector of the quantities exchanged between n and m in the direction from m to n , q_{mn} , for all $m \in \Omega_n \setminus \{n\}$. We use the following convention: if $q_{mn} \geq 0$, then n buys q_{mn} from m , otherwise ($q_{mn} < 0$) n sells $-q_{mn}$ to m . We let Q_n denote the *net import* of agent n : $Q_n := \sum_{m \in \Omega_n} q_{mn}$.

Each agent computes trading cost $\tilde{C}_n(\mathbf{q})$ using c_{nm} which might represent preferences measured through product differentiation prices [1], [12] on the possible trades with the neighbors, or taxes. The following condition on agent's trades called *trading reciprocity constraint* couples the decisions of two neighboring agents, ensuring for every node $m \in \Omega_n$ that $q_{mn} + q_{nm} = 0$. Note, that this formulation of the coupling constraints differs from the one presented in [1], as we use equality constraint in our model, instead of the inequality. That means that the energy surplus is not allowed in the electricity trading model. Let $\kappa_{nm} \in [0, +\infty)$ be the equivalent trading capacity between node n and node m , such that $\kappa_{nm} = \kappa_{mn}$ and $\forall m \in \Omega_n$. This equivalent trading capacity is used to bound the trading flows such that $q_{mn} \leq \kappa_{mn}$.

Local supply and demand should satisfy the following balance equality in each node n in \mathcal{N} : $D_n = G_n + \Delta G_n + \sum_{m \in \Omega_n} q_{mn}$, where ΔG_n is the *renewable energy sources (RES)-based generation* at node n , assumed to be non-flexible.

2.2. Electricity trading problem

As it was discussed in the introduction, each agent holds some private information that takes the form of nominal demand D_n^* and RES-based generation ΔG_n , which she does not desire to reveal to the other agents in the system. In the further analysis, we assume $y_n := D_n^* - \Delta G_n$ to be the private information of agent n . We assume that the agents desire to solve the electricity trading problem endowed with the set of coupled

constraints while not allowing the other agents to infer their values of y_n . We denote $\mathbf{x}_n := (D_n, G_n, \mathbf{q}_n)$ to be the vector that contains agent n 's decision variables and \mathbf{x}_{-n} is the vector of the other agents' actions. We recall the optimization problem formulated in [1] for the clearing of the peer-to-peer electricity market.

2.2.1. Peer-to-peer market design

In the peer-to-peer setting the problem of the electricity trading takes the form of generalized Nash equilibrium problem i.e., a game where the feasible sets of the players depend on the other players' actions. With the notation introduced above, it means that each agent solves the following optimization problem:

$$\min_{\mathbf{x}_n} \quad \Pi_n(\mathbf{x}_n), \quad (2a)$$

$$s.t. \quad \underline{G}_n \leq G_n \leq \overline{G}_n \quad (\underline{\mu}_n, \overline{\mu}_n) \quad (2b)$$

$$\underline{D}_n \leq D_n \leq \overline{D}_n \quad (\underline{\nu}_n, \overline{\nu}_n) \quad (2c)$$

$$q_{mn} + q_{nm} = 0 \quad (\zeta_{nm}) \quad (2d)$$

$$q_{mn} \leq \kappa_{mn} \quad (\xi_{nm}) \quad (2e)$$

$$D_n = G_n + \Delta G_n + \sum_{m \in \Omega_n} q_{mn} \quad (\lambda_n), \quad (2f)$$

where the corresponding dual variables are placed in blue at the right of each constraint. Note that in (2) the feasible set of the agent n can be rewritten in a more compact form $\mathcal{C}_n(\mathbf{x}_{-n}) = \{\mathbf{x}_n | (2b) - (2f) \text{ hold}\}$. This notation will be used later in the paper.

We introduce the following assumption to guarantee that the interface trading capacities are big enough to supply trading needs of all the agents and that differentiation prices are symmetric for trading with the root node.

Assumption 1. We assume that there are large trading capacities from and to node 0 – that is $\xi_{0n} = \xi_{n0} = 0 \forall n \in \mathcal{N}$ and $c_{n0} = c_{0n}$ for all $n \in \mathcal{N}$.

The following subsection describes the computation of $\tilde{C}_n(\mathbf{q})$ in the different setting for the differentiation prices.

2.3. Computation of the trading cost

Under the conditions of Assumption 1, Proposition 8 in [1] states that:

Proposition 2. For any couple of nodes $n \in \mathcal{N}, m \in \Omega_n, m \neq n$ with asymmetric preferences (such as $c_{mn} > c_{nm}$ or $c_{mn} < c_{nm}$) imply that the node with the smaller preference for the other saturates the line.

We focus on two opposite instances:

1. All c_{nm} are homogeneous. That means that $c_{nm} = c$ for all $n, m \in \mathcal{N}$. This case reflects the interpretation of c_{nm} as the taxes for energy trading, that should be naturally non-discriminating among agents. In this case bilateral trade cost is given by:

$$\tilde{C}_n(\mathbf{q}_n) = c \cdot Q_n \quad (3)$$

2. All c_{nm} for $m, n \neq 0$ are heterogeneous. This framework represents the case, when all $c_{nm}, m, n \neq 0$ are drawn from some continuous distribution (e.g. uniform). Under the Assumption 1 we are able to obtain the expressions for $\tilde{C}_n(\mathbf{q}_n)$ in this framework for agent n . Again using Proposition 2 we have that $q_{n0} = Q_n - \sum_{m \in \Omega_n, m \neq 0} \kappa_{nm} \text{sgn}(c_{mn} - c_{nm})$, where Q_n is obtained by combining (2f) and expressions for D_n, G_n . Thus, we are able to obtain the cost expressions for each agents n directly:

Proposition 3. Bilateral trade costs for any agent $n \in \mathcal{N}$ in the network except root node 0 are given by

$$\begin{aligned} \tilde{C}_n(\mathbf{q}_n) = & c_{0n} [Q_n - \sum_{m \in \Omega_n, m \neq 0} \kappa_{nm} \text{sgn}(c_{mn} - c_{nm})] \\ & + \sum_{k \in \Omega_n, k \neq 0} c_{nk} \kappa_{nk} \text{sgn}(c_{kn} - c_{nk}). \end{aligned} \quad (4)$$

Bilateral costs for node 0 are expressed as

$$\tilde{C}_0(\mathbf{q}_0) = \sum_{n \in \Omega_0} c_{0n} \left[\sum_{m \in \Omega_n, m \neq 0} \kappa_{nm} \text{sgn}(c_{mn} - c_{nm}) - Q_n \right] \quad (5)$$

Remark 4. We do not impose any condition on the ratio between the values of the coefficients c_{nm} . Choosing $c_{0n} < c_{mn}, \forall m, n \in \mathcal{N}$, we can ensure the preference for the local trades.

3. Intermediate case. To demonstrate the difficulties arising in the general case for computing bilateral trades, we consider the intermediate case, in which there exists **one** additional symmetric relation $c_{n'm'} = c_{m'n'}$ for $m', n' \neq 0$. Thus, for this pair of nodes we have that

$$Q_{n'} = q_{0n'} + q_{m'n'} + \sum_{k \neq m' \in \Omega_{n'}} \kappa_{n'k} \text{sgn}(c_{kn'} - c_{n'k})$$

$$Q_{m'} = q_{0m'} + q_{n'm'} + \sum_{k \neq n' \in \Omega_{m'}} \kappa_{m'k} \text{sgn}(c_{km'} - c_{m'k}),$$

where $q_{m'n'} = -q_{n'm'}$, which gives us a system of two equations with three unknown variables $q_{0n'}, q_{0m'}, q_{m'n'}$. Writing the similar equation for every node $k \neq m', n', 0$, we get $N - 3$ equations with $N - 3$ unknowns and adding the expression for Q_0 we obtain linear system with N independent equations and N unknown variables. It follows that adding even one symmetric relation leads to the system of N equations with $N + 1$ unknowns.

2.3.1. On the link between electricity trading and communication game

It is shown in [1], that at the VE, agent n 's decision variables \mathbf{x}_n^* depend on the dual variable λ_n , which, under the Assumption 1 is aligned across agents: $\lambda_n = \lambda_0, \forall n \in \mathcal{N}$, where λ_0 is the uniform market clearing price. The equilibrium expressions, provided in [1], also hold for our model with equality constraint (2d). λ_0 depends on the private information y_n of the agents. Formally, λ_0 is given by:

$$\lambda_0 = \frac{\sum_n y_n + \sum_n \frac{b_n}{a_n}}{\sum_n \left(\frac{1}{2a_n} + \frac{1}{a_n} \right)} \quad (6)$$

and the decision variables D_n and G_n are given at the equilibrium by the following expressions: $D_n(\mathbf{y}) = D_n^* - \frac{1}{2a_n}\lambda_0$, $G_n(\mathbf{y}) = -\frac{b_n}{a_n} + \frac{1}{a_n}\lambda_0$. The expression for Q_n is obtained from the supply demand equality condition (2f): $Q_n(\mathbf{y}) = D_n^* + \frac{b_n}{a_n} - (\frac{1}{a_n} + \frac{1}{2a_n})\lambda_0 - \Delta G_n$.

Thus, to solve (2) each agent needs to compute the uniform market clearing price λ_0 , which requires a knowledge of all the $(y_n)_n$ in the system. It leads to a question for each agent n of how to determine the report of her private information, so that it has the minimal impact on her cost, while guaranteeing that the certain level of privacy is met. That is, each agent n anticipates the form of the solution of the electricity trading problem at the equilibrium and determines the report \tilde{y}_n of her private information, that she submits to the other agents in the system.

In order to do so, each agent n minimizes the difference between the cost of the problem with the modified values and the optimal solution of the problem (2) with the truthful reports Π_n^* :

$$\begin{aligned} \min_{\tilde{y}_n} \quad & \mathbb{E} \left[\Pi_n(\tilde{y}_n, \tilde{\mathbf{y}}_{-n}) - \Pi_n^* \right], \\ \text{s.t.} \quad & \mathbf{x}_n^*(\tilde{\mathbf{y}}) \in \mathcal{C}_n(\mathbf{x}_{-n}^*(\tilde{\mathbf{y}})), \end{aligned} \quad (7)$$

where the expectation is taken in order to account for both randomized and deterministic cases. Note that \mathbf{x}_n^* depends on $\tilde{\mathbf{y}}$ because in the expressions for the decision variables $D_n(\cdot)$, $G_n(\cdot)$ and $q_n(\cdot)$ we use the reports $\tilde{\mathbf{y}}$ instead of the true values \mathbf{y} as the input. Also note that Π_n^* is a constant as it is calculated using true values of \mathbf{y} , thus it can be omitted from the objective function.

Remark 5. In (7) we assume that the form of the electricity trading problem is known by all the agents in the system. It enables each agent to anticipate the **form of the solution** $x_n^*(\cdot)$, for all $n \in \mathcal{N}$ and thus, based on this form to decide on the optimal information $\tilde{y}_n, \forall n \in \mathcal{N}$ to report to the other agents **before** they actually obtain the solution of the electricity trading problem. Note that it differs from [4], as we take the form of the solution \mathbf{x}^* of the GNEP as given.

2.4. Communication game

The report of the agent n takes the form $\tilde{y}_n = \hat{y}_n + \varepsilon_n$. The first part of the report captures the ability of agent n to act strategically on her report by determining the deterministic part \hat{y}_n that solves the cost minimization problem. In the second part of the report, each agent implements a randomized mechanism $M(\cdot)$ by choosing the noise ε_n to add to \hat{y}_n in order to preserve a certain level of privacy.

2.4.1. Privacy loss definition

First, we define an upper bounded distance as a symmetric adjacency relation $y_n \simeq \hat{y}_n$ for agent n : $y_n \simeq \hat{y}_n \iff d(y_n, \hat{y}_n) \leq \alpha_n$, where α_n is chosen beforehand and reflects the amount of information agent n desires to preserve [22].

Definition 6 (Privacy loss). Given a randomized mechanism M , let $p_{M(y_n)}(z)$ denote the density of the random variable $Z =$

$M(y_n)$. The privacy loss function of $M(\cdot)$ on a pair of $y_n \simeq \hat{y}_n$ is defined as $l_{M, y_n, \hat{y}_n}(z) = \log(p_{M(y_n)}(z)/p_{M(\hat{y}_n)}(z))$. The privacy loss random variable $L_{M, y_n, \hat{y}_n} := l_{M, y_n, \hat{y}_n}(Z)$ is the transformation of the output random variable $Z = M(y_n)$ by the function l_{M, y_n, \hat{y}_n} .

We assume that each agent samples a Gaussian noise $\varepsilon_n \sim \mathcal{N}(0, \sigma_n^2)$, thus obtaining the report $\tilde{y}_n \sim \mathcal{N}(\hat{y}_n, \sigma_n^2)$. When the Gaussian isotropic random noise is added to the deterministic value of the input, it is well-known that the privacy loss random variable is also Gaussian:

Lemma 7 ([2]). The privacy loss L_{M, y_n, \hat{y}_n} of a Gaussian output perturbation mechanism follows a distribution $\mathcal{N}(\eta, 2\eta)$, with $\eta = D^2/2\sigma^2$, where $D = \|y_n - \hat{y}_n\|$.

2.4.2. A randomized mechanism for information reporting

We aim to allow agents to be able to decide on the optimal noise added to their private information, by choosing the optimal variance V_n . For simplicity of notations, we denote $V_n := \sigma_n^2$.

First, each agent chooses the neighboring input $\hat{y}_n \simeq y_n$, on which she later implements $M(\cdot)$. It is reflected in the constraint (8d). In the constraint (8e), the expectation of the privacy loss random variable measures the expected privacy loss of the mechanism $M(y_n)$ on the fixed private information y_n, \hat{y}_n . In other words, it shows, how much information can be extracted from the report \tilde{y}_n . Note, that it is exactly the Kullback-Leibler divergence (or the relative entropy) between M 's output distributions on y_n and \hat{y}_n .

Thus, to decide on the optimal value of the report \tilde{y}_n , each agent needs to solve the following optimization problem:

$$\min_{\hat{y}_n, V_n} \quad \mathbb{E}_{\varepsilon_n \sim \mathcal{N}(0, V_n)} \left[\Pi_n(\hat{\mathbf{y}}, \varepsilon) \right] \quad (8a)$$

$$\text{s.t.} \quad \underline{G}'_n \leq \mathbb{E}_{\varepsilon_n \sim \mathcal{N}(0, V_n)} [G_n(\hat{\mathbf{y}})] \leq \overline{G}'_n \quad (\underline{\mu}_n, \overline{\mu}_n) \quad (8b)$$

$$\underline{D}'_n \leq \mathbb{E}_{\varepsilon_n \sim \mathcal{N}(0, V_n)} [D_n(\hat{\mathbf{y}})] \leq \overline{D}'_n \quad (\underline{\nu}_n, \overline{\nu}_n) \quad (8c)$$

$$(\hat{y}_n - y_n)^2 \leq \alpha_n^2 \quad (\underline{\gamma}_n, \overline{\gamma}_n) \quad (8d)$$

$$\mathbb{E}[L_{M, y_n, \hat{y}_n}] \leq A_n \quad (\underline{\beta}_n, \overline{\beta}_n) \quad (8e)$$

where $\underline{G}'_n = \underline{G}_n + \omega_{G_n}$, $\overline{G}'_n = \overline{G}_n - \omega_{G_n}$ and $\underline{D}'_n = \underline{D}_n + \omega_{D_n}$, $\overline{D}'_n = \overline{D}_n - \omega_{D_n}$, in which $\omega_{D_n}, \omega_{G_n} > 0$ are introduced in order to account for the strictly feasible solutions of problem (2). In the numerical experiments we set $\omega_{D_n}, \omega_{G_n}$ to be a small, e.g. 10^{-3} .

As it is shown below, the only term depending on the variance in the utility function of the agent n is $\frac{B_n}{B} \sum_m V_m$. In the special case $y_n = \hat{y}_n$ for some n , where the constraint (8e) $\frac{(\hat{y}_n - y_n)^2}{2V_n} \leq A_n$ holds for any $0 < V_n < \infty$. The possible convention could be to exclude this constraint from the consideration, when $y_n = \hat{y}_n$ and set $V_n = 0$.

The condition for the uniform market clearing price λ_0 to have a form given in (6) is to have zero total net import, i.e. $\sum_n Q_n = 0$. In the case a *fully coordinated mechanism* is implemented, i.e the local MO has an access to all the constraints

and parameters of the agents and solves the problem in a centralized way, it is possible to oblige agents to align their reports $\tilde{\mathbf{y}}$ such that $\mathbb{E}\left[\sum_n Q_n(\tilde{\mathbf{y}})\right] = \sum_n (y_n - \hat{y}_n) = 0$. It follows that $\sum_n \hat{y}_n = \sum_n y_n$. So, when we compute λ_0 using $\tilde{\mathbf{y}}$ instead of \mathbf{y} , we obtain $\mathbb{E}[\lambda_0(\tilde{\mathbf{y}})] = \frac{1}{B}(\sum_n \hat{y}_n + \sum_n \frac{b_n}{a_n}) = \frac{1}{B}(\sum_n y_n + \sum_n \frac{b_n}{a_n})$. Thus, the final market clearing price does not depend on the reports of the agents, which is formalized in the following statement:

Proposition 8. *When the prosumers align their reports $\tilde{\mathbf{y}}$ so that the condition $\mathbb{E}\left[\sum_n Q_n(\tilde{\mathbf{y}})\right] = 0$ is met, then the uniform market clearing price λ_0 depends only on the true values of their initial parameters \mathbf{y} .*

In the case a peer-to-peer communication mechanism is implemented, the sum of the net imports at each node might not be equal to zero. Indeed, agents might have incentives to violate this condition in order to decrease their costs. Thus, the condition $\sum_n Q_n = 0$ might not hold.

On the market level it is necessary for the condition of zero total net import to hold such that supply and demand balance each other in problem (2) [15]. Also, note that non zero total net import $\sum_n Q_n \neq 0$ implies that there exists at least one pair of agents (n, m) with $q_{nm} + q_{mn} \neq 0$. Besides, this might cause the violation of the capacity condition $q_{nm} \leq \kappa_{nm}$. It means that the local Market Operator (MO) has to compensate the difference $\mathbb{E}\left[\sum_n Q_n(\tilde{\mathbf{y}})\right]$ caused by the lack of coordination in the agents' reports. In the case $\mathbb{E}\left[\sum_n Q_n(\tilde{\mathbf{y}})\right] \leq 0$, there is an energy surplus in the system, which can be sold by the MO (by the intermediate of an aggregator) to the wholesale market at price p^0 . If $\mathbb{E}\left[\sum_n Q_n(\tilde{\mathbf{y}})\right] \geq 0$, then the MO (by the intermediate of an aggregator) has to buy the energy on the wholesale market at price p^0 , which depends on the wholesale market price, in order to supply the system demand.

When the constraints and the private information of the agents are not shared, the MO only knows the aggregate deviation $\sum_n (y_n - \hat{y}_n)$ thus penalties imposed on the agents depend on it and not on the personal deviation $y_n - \hat{y}_n$ of the agent n .

Remark 9. *For prosumers, imports/exports of energy from/to the community manager are possible at prices p^-/p^+ respectively such that $p^+ \leq p^0 \leq p^-$. To avoid non-differentiability in the utility function, we let $p^+ = p^0 = p^-$.*

To compensate for the cost of buying the lack of energy at the local market level from the wholesale market, the MO imposes penalty to each prosumer that takes the form $P(\tilde{\mathbf{y}}) = \frac{p^0}{N} \sum_n (y_n - \hat{y}_n)$. Note that in case of the excess of the production on the local market level, the prosumers will be equally reimbursed based on the surplus produced. The division by N is introduced in order to equally split the burden of the non zero total net import and mitigate the possible volatility of the price p^0 .

Assumption 10. *A local MO ensures the compensation for the nonzero total net import. This implies that the formula for λ_0 in (6) is used by all the prosumers to compute their decision variables.*

Proposition 11. *Dual variables $\underline{\beta}_n, \bar{\beta}_n$ for the constraint (8e) can be interpreted as the privacy price for agent n and are computed by the formula*

$$(\bar{\beta}_n + \underline{\beta}_n)^2 = \frac{B_n^2 (\hat{y}_n - y_n)^2}{4B^4}$$

Proof. Constraint (8e) can be rewritten as follows, when we consider $V_n \neq 0$ for all $n \in \mathcal{N}$: $\mathbb{E}[L_{M, y_n, \hat{y}_n}] \leq A_n \iff (\hat{y}_n - y_n)^2 \leq 2V_n A_n$. In the following analysis, we denote $B_n := \frac{1}{a_n} + \frac{1}{2a_n}$ and $B := \sum_n B_n$. The objective function (8a) of the agent n depends linearly on the V_n , thus attaining the minimum with respect to this decision variable on the lower boundary of the feasible region. The lower boundary is given by the constraint (8e), from which we can conclude that $V_n = \frac{(\hat{y}_n - y_n)^2}{2A_n}$ for any given value of the decision variable \hat{y}_n for any agent n . From the KKT conditions we have that $V_n = \frac{2B^4}{A_n B_n^2} (\bar{\beta}_n + \underline{\beta}_n)^2$, from which we obtain the expression for $(\bar{\beta}_n + \underline{\beta}_n)^2$.

First, from the complementarity conditions we know that either of $\underline{\beta}_n, \bar{\beta}_n$ equals 0. Clearly, it is non-negative term that appears in the utility of the agent n at the equilibrium. Thus, we can view $\underline{\beta}_n, \bar{\beta}_n$ as a *privacy price*. ■

Remark 12. *The privacy price increases with respect to the distance between the truthful (y_n) and biased (\hat{y}_n) values of agent n 's private information.*

3. Equilibrium problems

3.1. Aggregate game formulation

Note that as λ_0 depends on the sum of $\sum_n (D_n^* - \Delta G_n)$, the objective function in (8) has an *aggregative game* structure, i.e. it depends on player n 's decision \hat{y}_n and on the aggregate of the other agents' decisions.

Below we provide the computations of the objective function of agents $\Pi_n(\tilde{y}_n, \hat{y}_{-n})$ both in (i) the fully coordinated mechanism and (ii) the peer-to-peer coordination mechanism.

To arrive to this closed form expression, we observe that $\tilde{y}_n \sim \mathcal{N}(\hat{y}_n, V_n)$. The sum of normal variables is a normal variable itself: $\sum_n \tilde{y}_n \sim \mathcal{N}(\sum_n \hat{y}_n, \sum_n V_n)$, from where it follows that $(\sum_n \tilde{y}_n + \sum_n \frac{b_n}{a_n}) \sim \mathcal{N}(\sum_n \hat{y}_n + \sum_n \frac{b_n}{a_n}, \sum_n V_n)$. Using a formula for the second moment of the normal distribution, expression (3) and Proposition 3, we obtain the expression for the utility of the agents in cases (i) and (ii).

In the homogeneous differentiation price case $c_{nm} = c$, the cost function of agent n is given by

$$\begin{aligned} \mathbb{E}[\Pi_n(\tilde{\mathbf{y}})] &= \frac{B_n}{2B^2} \left[\left(\sum_m \hat{y}_m + \sum_m \frac{b_m}{a_m} \right)^2 + \sum_m V_m \right] \\ &+ c \left[D_n^* - \Delta G_n + \frac{b_n}{a_n} - \frac{B_n}{B} \left(\sum_m \hat{y}_m + \sum_m \frac{b_m}{a_m} \right) \right] \\ &+ \frac{p^0}{N} \sum_m (y_m - \hat{y}_m) - \frac{b_n^2}{2a_n} + d_n - \tilde{b}_n, \end{aligned}$$

Expression for the utility in the case when c_{nm} are heterogeneous is similar, except that for $\tilde{C}_n(\mathbf{q}_n)$, we use the expressions from Proposition 3.

3.2. GNE computation

3.2.1. c_{nm} are homogeneous

From the computations of the KKT conditions, we obtain that $\frac{B_n}{B^2} \sum_{m \in \mathcal{N}} \hat{y}_m + M'_n = 0$, $\forall n \in \mathcal{N}$, where $M'_n := \frac{B_n}{B^2} \sum_m \frac{b_m}{a_m} - \frac{p^0}{N} - \frac{cB_n}{B} + \frac{1}{a_n B} (\bar{\mu}_n - \underline{\mu}_n) + \frac{1}{2a_n B} (\underline{\nu}_n - \bar{\nu}_n) + \bar{\gamma}_n - \underline{\gamma}_n + \bar{\beta}_n - \underline{\beta}_n$.

3.2.2. c_{nm} are heterogeneous for $m \neq 0$

Analogously, first order stationarity conditions for agents $n \in \mathcal{N}$ are given by $\frac{B_n}{B^2} \sum_{m \in \mathcal{N}} \hat{y}_m + M''_n = 0$, with $M''_n := \frac{B_n}{B^2} \sum_n \frac{b_n}{a_n} - c_{0n} \frac{B_n}{B} - \frac{p^0}{N} + \frac{1}{a_n B} (\bar{\mu}_n - \underline{\mu}_n) + \frac{1}{2a_n B} (\underline{\nu}_n - \bar{\nu}_n) + \bar{\gamma}_n - \underline{\gamma}_n + \bar{\beta}_n - \underline{\beta}_n$ and $M''_0 = \frac{B_0}{B^2} \sum_n \frac{b_n}{a_n} + \frac{1}{a_0 B} (\bar{\mu}_0 - \underline{\mu}_0) + \sum_{n \neq 0} c_{0n} \frac{B_n}{B} - \frac{p^0}{N} + \frac{1}{2a_0 B} (\underline{\nu}_0 - \bar{\nu}_0) + \bar{\gamma}_0 - \underline{\gamma}_0 + \bar{\beta}_0 - \underline{\beta}_0$.

3.3. Uniqueness of the Variational Equilibrium

Definition 13. An operator $F : K \subseteq \mathbb{R}^n \rightarrow \mathbb{R}^n$ is strongly monotone on the set $\hat{K} \subseteq K$ with monotonicity constant $\alpha > 0$ if $(F(x) - F(y))^\top (x - y) \geq \alpha \|x - y\|^2$, $\forall x, y \in \hat{K}$. The operator is monotone if $\alpha = 0$

In order to show the uniqueness of the VE of the problem (8), we check if the operator

$$F(\hat{\mathbf{y}}, \mathbf{V}) := [\nabla_n \mathbb{E}(\Pi_n(\hat{\mathbf{y}}, \mathbf{V}))]_{n=1}^N \quad (9)$$

is strongly monotone. To do so, we use the following lemma:

Lemma 14 ([6]). A continuously differentiable operator $F : K \subseteq \mathbb{R}^n \rightarrow \mathbb{R}^n$ is α -strongly monotone with monotonicity constant α (resp. monotone) if and only if $\nabla_x F(x) \succeq \alpha I$ (resp. $\nabla_x F(x) \succeq 0$) for all $x \in K$. Moreover, if K is compact, then there exists $\alpha > 0$ such that $\nabla_x F(x) \succeq \alpha I$ for all $x \in K$ if and only if $\nabla_x F(x) \succ 0$ for all $x \in K$.

For homogeneous differentiation price $c_{nm} = c$, $F(\hat{\mathbf{y}}, \mathbf{V})$ writes as follows:

$$F(\hat{\mathbf{y}}, \mathbf{V}) = \text{col} \left\{ \left(\frac{B_i}{B^2} \left(\sum_m \hat{y}_m + \sum_m \frac{b_m}{a_m} \right) - c \frac{B_i}{B} - \frac{p^0}{N}, \frac{V_i B_i}{B^2} \right)_{i=0}^{N-1} \right\} \quad (10)$$

When differentiation prices c_{nm} are heterogeneous for $m \neq 0$, operator $F(\hat{\mathbf{y}}, \mathbf{V})$ is obtained similarly, but for the expressions of $\hat{C}_n(\mathbf{q}_n)$, we take expressions from Proposition 3.

Lemma 15. Operator $F(\hat{\mathbf{y}}, \mathbf{V})$ defined in (10) is strongly monotone.

Proof. The proof can be found in the Appendix. ■

Proposition 16. By the strong monotonicity of $F(\hat{\mathbf{y}}, \mathbf{V})$, VE of the game (8) is unique [16].

3.4. Generalized Potential Game extension

Assumption 17. Assume that $\forall i, j \in \mathcal{N} : \frac{B_i}{B} \simeq \frac{B_j}{B}$, i.e. each agent n 's contribution B_n to the sum B is relatively small. Denote $H := \frac{B_n}{B} \forall n \in \mathcal{N}$.

Proposition 18. Under Assumption 17, the game (8) is a Generalized Potential Game.

Proof. The proof can be found in the Appendix. ■

Generalized Potential Games constitute a subclass of games for which the convergence of the BR algorithms is established [7] in the deterministic case. Taking into account that the BR scheme is suited for our private framework, an interesting direction of the research would be to establish the convergence of the BR algorithm for the stochastic NE of the GPG.

4. Numerical Results

4.1. Algorithm description

In the paper [21], authors employ the penalized individual cost functions to deal with coupled constraints and provide a three stochastic gradient strategies with constant step-sizes in order to approach the Nash Equilibrium. In order to establish their results, authors consider the model with the operator $F(\hat{\mathbf{y}}, \mathbf{V})$ to be strongly-monotone and Lipschitz continuous, which holds for our case. We consider the scheme, called by the authors as *Diffusion Adapt-then-Penalize*:

$$\begin{cases} \psi_\nu^k = \hat{y}_\nu^{k-1} - \mu \nabla_{\hat{y}_\nu} \Pi_\nu(\hat{y}_\nu, \tilde{\mathbf{y}}_{-\nu}) \\ \hat{y}_\nu^k = \psi_\nu^k - \mu R \nabla_{\hat{y}_\nu} (\theta_\nu(\psi_\nu^k)), \end{cases}$$

where μ denotes the step-size, R - penalty parameter and $\theta_\nu(\cdot)$ - penalty function for the coupling constraints, which we choose to be the sum over all the constraints of the form $x \leq 0$, of all functions $p_\nu(x)$ such that $p_\nu(x) = \sum \mathbb{I}_{x \geq 0} \cdot x^2/2$.

4.2. Numerics

We consider the IEEE 14-bus network system, which is depicted in Figure 1, where each bus (node) of the network corresponds to a prosumer in our model. We consider the system, which consists of the agents with the non-zero self-generation and demand parameters, thus we exclude one interim node 6, which sole purpose in the initial 14-bus system is to connect the flows. Thus, in our model there are 13 buses (nodes). As parameters of the algorithm, we set $\mu = 0.003$ and $R = 700$. We first focus on the homogeneous differentiation price case $c_{nm} = 1.0$ [\$/MWh], for all $n, m \in \mathcal{N}$. The cost p^0 , used by local MO to trade with the wholesale market, is set to be higher than c and equals 5.0 [\$/MWh]. The natural assumption is the homogeneity of the self-generation parameters of the prosumers, which we set to be $a_n = 0.5, b_n = 6.0$ for all $n \in \mathcal{N}$. Also, there are three nodes (2, 5, 7) that are additionally equipped with a RES-based generation. Values on the links between the nodes on Figure 1 specify the trading capacity parameters κ_{nm} . Recall from the Assumption 1 that there are large trading capacities to and from node 0, thus we do not

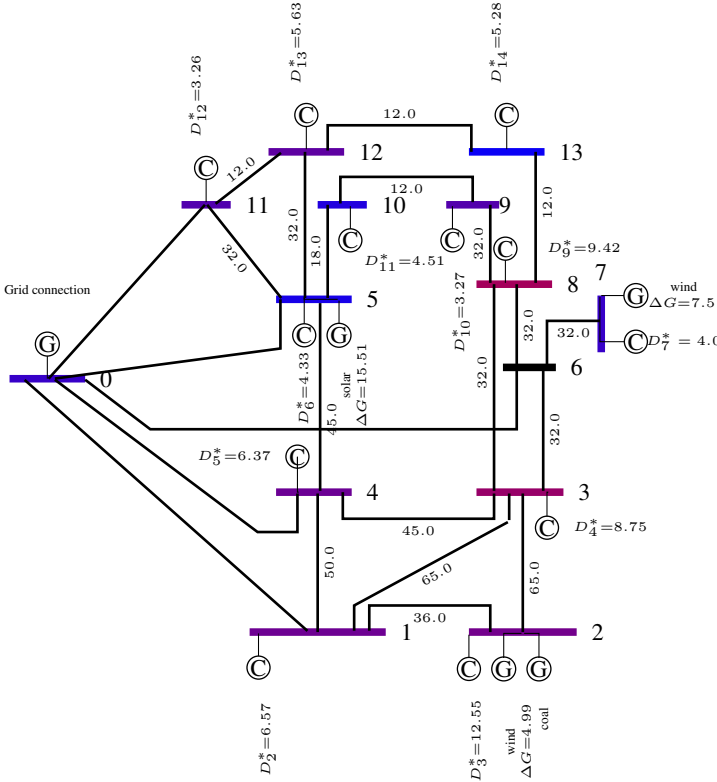

Figure 1: IEEE 14-bus network system

specify them on the scheme. The nominal demands and RES-based generations in Figure 1 are given in [GWh]. All the parameters that are used to calibrate the agents' utility functions are specified in Table 1.

Table 1: Agents' utility function parameters.

Node	\tilde{a}	\tilde{b}	\tilde{d}	\bar{D}	\bar{G}
0	1.5	0.0	9	25.0	100.0
1	1.18	5.09	15	26.7	100.0
2	1.0	3.78	14	99.2	80.0
3	0.57	4.36	0.0	52.8	20.0
4	1.24	5.03	0.0	12.6	20.0
5	1.62	3.04	2.0	16.2	20.0
6	1.54	4.29	0.0	19.9	20.0
7	1.5	0.0	11.0	25.0	50.0
8	0.31	2.75	0.0	34.5	20.0
9	4.36	4.67	0.0	14.0	20.0
10	1.63	3.32	0.0	8.5	20.0
11	5.16	5.5	0.0	11.1	20.0
12	1.96	6.21	0.0	18.5	20.0

We measure the impact of our mechanism on the cost of the agents, measured through the agent's utility gap $\mathbb{E}[\Pi_n^* - \Pi_n(\tilde{y}_n, \tilde{y}_{-n})]$ for each agent n . In Figure 2, we plot the utility gap as a function of A_n for all the agents. We observe that the nodes 3 and 8 decrease their costs the most among all the prosumers and nodes 9 and 11 have, on the contrary, increasing costs. From Table 1 it can be seen that node 3 and 8

have the minimal flexible demand coefficients: $\tilde{a}_3 = 0.57$ and $\tilde{a}_8 = 0.31$. Similarly, nodes 9 and 11 have the biggest flexible demand coefficients: $\tilde{a}_9 = 4.36$ and $\tilde{a}_{11} = 5.16$. The cost of the demand flexibility affects the utility of the agents, i.e. small cost allows them to adjust their demand such that they can decrease their costs, while deviating from their true values.

For the graphs shown below, we set $\alpha_n = 3.0$ when we plot the dependance w.r.t. A_n , and $A_n = 10.0$ when we plot the dependance w.r.t. α_n . For this choice of parameters, the color of the nodes in Figure 1 shows the *privacy price* $\underline{\beta}_n, \bar{\beta}_n$ [\$/MWh] from Proposition 11 in each $n \in \mathcal{N}$. Light blue denotes the lowest privacy price ($1.129 \cdot 10^{-3}$ [\$/MWh]) and dark violet denotes the highest ($2.827 \cdot 10^{-2}$ [\$/MWh]).

Figure 3 represents the dependence of the plot of the utility gap on the parameter α_n of the agents. It is shown, that when the maximal bound on the distance is low, the agents expectedly deviate from their costs Π_n^* . As soon as α_n increases, thus providing more possibility to deviate, agents tend to show the similar behavior as on the plot with respect to A_n : nodes 3 and 8 gain the most and nodes 9 and 11 have the increasing costs.

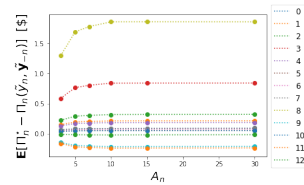

Figure 2: Utility gap wrt. A_n

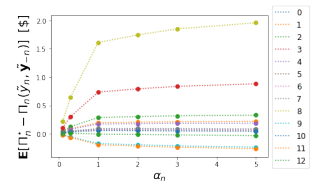

Figure 3: Utility gap wrt. α_n

Figures 4 and 5 depict the dependance of the social cost of the system w.r.t. A_n and α_n respectively. We compare three instances: peer-to-peer communication mechanism, fully coordinated communication mechanism and the social cost evaluated in the truthful reports. Note, that the latter one provides the same cost when Proposition 8 holds.

It can be seen that increase in A_n affects the peer-to-peer communication the most, which is caused by the decrease of the privacy price induced by the noise in the agents' reports (recall, that the variance is given by $V_n = \frac{2B^4}{A_n B_n^2} (\bar{\beta}_n + \underline{\beta}_n)^2$), thus allowing them to compute their decision variables more precisely. Clearly, it affects the centralized communication mechanism less. On the other hand, increase of the α_n affects the centralized communication mechanism the most, as it allows the local MO to find an optimal solution for each agent in the system, thus leading to the biggest decrease in the costs.

The results above are shown in the homogeneous A_n, α_n and c_{nm} case. Heterogeneity in the distance parameters α_n and A_n does not affect the behavior of the agents in the system described above. Nevertheless, setting parameters α_n to be small for those who deviate the most (e.g. nodes 3 and 8) can bound their influence on the sum $\sum_n \tilde{y}_n$, thus, bounding the deviation from the $\sum_n y_n$.

In the case of heterogeneous differentiation prices c_{nm} for $n, m \neq 0$, we compute the trading costs of the agents, using the expressions given in Proposition 3. Numerical experiments show the same behavior for all the agents in the system, while

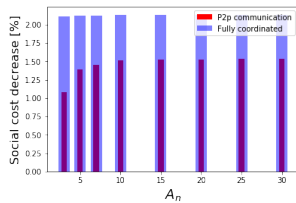

Figure 4: Social cost decrease wrt. A_n

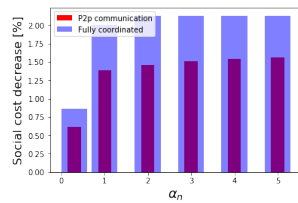

Figure 5: Social cost decrease wrt. α_n

distinguishing the node 0: in this setting it decreases its cost the most. An interesting research direction would be to adapt the penalty for the prosumers in order to account for this behavior.

5. Conclusion

In our work we considered a peer-to-peer electricity market, in which agents have private information. The problem is modeled as a noncooperative communication game, which takes the form of a GNEP, where the agents determine their randomized reports to share with the other market players, while anticipating the form of the peer-to-peer market equilibrium. Agents decide on the deterministic and random parts of the report, such that the (a) the distance between the deterministic part of the report and the truthful private information is bounded (b) expectation of the privacy loss random variable is bounded. This allows them to act strategically on the values of the deterministic part and to choose the random noise included in their reports. We characterized the equilibrium of the problem and proved the uniqueness of the Variational Equilibria. We provided a closed form expression for the privacy price. The theoretical results are illustrated on the 14-bus IEEE network, using the stochastic gradient descent algorithm. We show the impact of the privacy preservation caused by inclusion of random noise and deterministic deviation from agents' true values.

Since our problem has a potential form under mild assumptions, as the next step, we will focus on the development of the distributed learning algorithm for the stochastic NE of the Generalized Potential Game. Another interesting research direction would be to consider the decentralized communication mechanism, where agents do not have the ability to anticipate the form of the uniform market price.

References

- [1] H. Le Cadre, P. Jacquot, C. Wan and C. Alasseur, "Peer-to-Peer Electricity Markets: From Variational to Generalized Nash Equilibrium", *European Journal of Operational Research*, vol. 282, no.2, pp. 753–771, 2020.
- [2] B. Balle and Yu-Xiang Wang, "Improving the Gaussian Mechanism for Differential Privacy: Analytical Calibration and Optimal Denoising", *Proceedings of the 35th International Conference on Machine Learning*, 2018.
- [3] F. Farokhi, H. Sandberg, "Optimal Privacy-Preserving Policy Using Constrained Additive Noise to Minimize the Fisher Information", *IEEE 56th Annual Conference on Decision and Control (CDC)*, Melbourne, Australia, 2017
- [4] F. Fioletto, L. Mitridati and P. Van Hentenryck "Differential Privacy for Stackelberg Games", *Proceedings Proceedings of the Twenty-Ninth International Joint Conference on Artificial Intelligence (IJCAI-20)*, 2020

- [5] G. Belgioioso and S. Grammatico "A Douglas–Rachford Splitting for Semi-decentralized Equilibrium Seeking in Generalized Aggregative Games", *IEEE Conference on Decision and Control (CDC)*, 2018
- [6] D. Paccagnan, B. Gentile, F. Parise, M. Kamgarpour and J. Lygeros, "Nash and Wardrop Equilibria in Aggregative Games With Coupling Constraints," *IEEE Transactions on Automatic Control*, vol. 64, no. 4, pp. 1373–1388, April 2019
- [7] F. Facchinei, V. Piccialli and M. Sciandrone, "Decomposition Algorithms for Generalized Potential Games", *Comput Optim Appl* 50, 2011
- [8] H. Gerard, V. Leclere, A. Philpott, "On risk averse competitive equilibrium", *Operations Research Letters*, vol. 46, no. 1, pp. 19–26, 2017.
- [9] V. Dvorkin, J. Kazempour, P. Pinson, "Electricity market equilibrium under information asymmetry", *Operations Research Letters*, vol. 47, no. 6, pp. 521–526, 2019.
- [10] S. Xie, H. Wang, Y. Hong, M. Thai, "Privacy Preserving Distributed Energy Trading", *Proceedings of the 40th International Conference on Distributed Computing Systems*, 2020
- [11] C. Murguia, I. Shames, F. Farokhi, D. Nedic, and H. Vincent Poor "On Privacy of Dynamical Systems: An Optimal Probabilistic Mapping Approach", *IEEE Transactions*, VOL. 14, NO. 8, 2020
- [12] Sorin E., Bobo L., Pinson P. "Consensus-based Approach to Peer-to-Peer Electricity Markets with Product Differentiation", *IEEE Transactions on Power Systems*, 2018
- [13] C. Goncalves, R. J. Bessa, P. Pinson, "A critical overview of privacy-preserving approaches for collaborative forecasting", *International Journal of Forecasting*, 2020
- [14] F. Moret and P. Pinson, "Energy collectives: A community and fairness based approach to future electricity markets", *IEEE Transactions on Power Systems*, vol. 34, no. 5, pp. 3994–4004, 2019.
- [15] F. Moret, P. Pinson, and A. Papakonstantinou, "Heterogeneous risk preferences in community-based electricity markets", *European Journal of Operational Research*, vol. 287, no. 1, pp. 36–48, 2020.
- [16] A. A. Kulkarni and U. V. Shanbhag, "On the variational equilibrium as a refinement of the Generalized Nash equilibrium", *Automatica*, vol. 48, no. 1, pp. 45–55, 2012.
- [17] J. B. Rosen, "Existence and Uniqueness of Equilibrium Points for Concave N-Person Game", *Econometrica*, vol. 33, no. 3, pp. 520–534, 1965.
- [18] T. Sousa, T. Soares, P. Pinson, F. Moret, T. Baroche, E. Sorin, *Peer-to-peer and community-based markets: A comprehensive review*, *Renewable and Sustainable Energy Reviews*, Volume 104, 2019
- [19] G. Belgioioso, W. Ananduta, S. Grammatico and C. Ocampo-Martinez, "Energy Management and Peer-to-peer Trading in Future Smart Grids: A Distributed Game-Theoretic Approach", *European Control Conference*, 2020.
- [20] W. Tushar, T. K. Saha, C. Yuen, D. Smith, and H. V. Poor, "Peer-to-Peer Trading in Electricity Networks: An Overview", *IEEE Trans. on Smart Grid*, vol. 11, no. 4, 2020
- [21] C. Yu, M. van der Schaar and A. H. Sayed, "Distributed Learning for Stochastic Generalized Nash Equilibrium Problems," in *IEEE Transactions on Signal Processing*, 2017
- [22] K. Chatzikokolakis, M. E. Andres, N. E. Bordenabe, and C. Palamidessi, "Broadening the scope of differential privacy using metrics", *In International Symposium on Privacy Enhancing Technologies Symposium*, 2013
- [23] J. Koshal, A. Nedic, U. Shanbhag, "Distributed Algorithms for Aggregative Games on Graphs", *Operations Research*, 2016

6. Appendix

6.1. Proof of Lemma 15

Proof. First, note that for heterogeneous c_{nm} , operator $F(\hat{\mathbf{y}}, \mathbf{V})$ writes as follows for nodes $i \neq 0$:

$$F(\hat{\mathbf{y}}, \mathbf{V}) = \text{col} \left\{ \left(\frac{B_i}{B^2} \left(\sum_m \hat{y}_m + \sum_m \frac{b_m}{a_m} \right) + \right. \right. \\ \left. \left. - c_{i0} \frac{B_i}{B} - \frac{p^0}{N}, \frac{V_i B_i}{B^2} \right)_{i=1}^{N-1} \right\}, \quad (11)$$

and for node 0 we can write it as follows:

$$F(\hat{\mathbf{y}}, \mathbf{V}) = \left(\frac{B_0}{B^2} \left(\sum_m \hat{y}_m + \sum_m \frac{b_m}{a_m} \right) + \right. \\ \left. + \sum_{m \neq 0} c_{0m} \frac{B_m}{B} - \frac{p^0}{N}, \frac{V_0 B_0}{B^2} \right). \quad (12)$$

We want to prove that the operator $F(\hat{\mathbf{y}}, \mathbf{V})$ defined in (10) or in (11) and (12) is strongly monotone.

We denote vector z to be $z := (\hat{y}_0, V_0, \dots, \hat{y}_{N-1}, V_{N-1})$. We need to investigate whether $\nabla_z F(\hat{\mathbf{y}}, \mathbf{V})$ is positive-definite.

Denote $F(\hat{\mathbf{y}}, \mathbf{V})_{i1} := \frac{B_i}{B^2} \left(\sum_n \hat{y}_n + \sum_n \frac{b_n}{a_n} \right) - c \frac{B_i}{B} - \frac{p^0}{N}$ for the homogeneous c_{nm} case, and $F(\hat{\mathbf{y}}, \mathbf{V})_{i2} = \frac{V_i B_i}{B^2}$. Similarly, for the heterogeneous c_{nm} case, denote $F(\hat{\mathbf{y}}, \mathbf{V})_{i1} := \frac{B_i}{B^2} \left(\sum_n \hat{y}_n + \sum_n \frac{b_n}{a_n} \right) - c_{i0} \frac{B_i}{B} - \frac{p^0}{N}$ for $i \neq 0$ and $F(\hat{\mathbf{y}}, \mathbf{V})_{01} := \frac{B_0}{B^2} \left(\sum_n \hat{y}_n + \sum_n \frac{b_n}{a_n} \right) + \sum_{m \neq 0} c_{0m} \frac{B_m}{B} - \frac{p^0}{N}$. Thus we have that $\frac{\partial F(\hat{\mathbf{y}}, \mathbf{V})_{i1}}{\partial \hat{y}_j} = \frac{B_i}{B^2}$, $\forall j \in \mathcal{N}$ and $\frac{\partial F(\hat{\mathbf{y}}, \mathbf{V})_{i2}}{\partial V_i} = \frac{B_i}{B^2}$. All other partial derivatives are 0. Thus $\nabla_z F(\hat{\mathbf{y}}, \mathbf{V})$ is a matrix defined with its entries to be

$$\nabla_z F(\hat{\mathbf{y}}, \mathbf{V})_{ij} = \begin{cases} \frac{B_{\frac{i+j}{2}}}{B^2} & \text{if } i, j \text{ are even} \\ \frac{B_{\frac{i+1}{2}}}{B^2} & \text{if } i, j \text{ are odd and } i = j \\ 0 & \text{otherwise} \end{cases}$$

Symmetric matrix A is positive definite on compact if its quadratic form is positive: $x^\top A x > 0$, $\forall x \in \mathbb{R}^n \setminus 0$. Note, that non-symmetric matrix A is positive definite iff symmetric matrix $\frac{1}{2}(A + A^\top)$ is. In our case the quadratic form is given by the following expression:

$$\frac{1}{2} z^\top (\nabla_z F(\hat{\mathbf{y}}, \mathbf{V}) + \nabla_z F(\hat{\mathbf{y}}, \mathbf{V})^\top) z = \\ = \frac{1}{B^2} \sum_{i=1}^N B_i \hat{y}_i^2 + \frac{1}{2B^2} \sum_{i=1}^N \sum_{j \neq i}^N (B_i + B_j) \hat{y}_i \hat{y}_j + \frac{1}{B^2} \sum_{i=1}^N B_i V_i \\ \geq \frac{1}{B^2} \sum_{i=1}^N B_i \hat{y}_i^2 + \frac{1}{B^2} \sum_{i=1}^N \sum_{j \neq i}^N \sqrt{B_i B_j} \hat{y}_i \hat{y}_j + \frac{1}{B^2} \sum_{i=1}^N B_i V_i \\ = \frac{1}{B^2} \left(\sum_{i=1}^N \sqrt{B_i} \hat{y}_i \right)^2 + \frac{1}{B^2} \sum_{i=1}^N B_i V_i,$$

which is positive for all $(\hat{y}_i, V_i)_i$ in the feasible region. ■

6.2. Proof of Proposition 18

Proof. The notion of Generalized Potential Game is widely used in the literature, see e.g. [7]. To verify that our game is indeed the potential game, consider function $\mathcal{P}(\hat{\mathbf{y}})$, defined as follows:

$$\mathcal{P}(\hat{\mathbf{y}}, \mathbf{V}) = \sum_{i=1}^N \left[\frac{H \hat{y}_i}{B} \left(\frac{1}{2} \sum_n \hat{y}_n + \sum_n \frac{b_n}{a_n} \right) - \frac{p^0 \hat{y}_i}{N} - \frac{cH \hat{y}_i}{B} \right. \\ \left. + \frac{H}{B} V_i \right]$$

We can check that it is a potential function. Indeed, for all $\hat{\mathbf{y}}_{-n}$, and for all admissible x_n, z_n, x'_n, z'_n :

$$\Pi_n(x_n, \hat{\mathbf{y}}_{-n}, x'_n, \mathbf{V}_{-n}) - \Pi_n(z_n, \hat{\mathbf{y}}_{-n}, z'_n, \mathbf{V}_{-n}) = \\ = \frac{H}{2B} \left[(x_n - z_n)(x_n + z_n + 2 \sum_{m \neq n} \hat{y}_m + 2 \sum_{k \in \mathcal{N}} \frac{b_k}{a_k}) \right] \\ - \frac{(x_n - z_n)cH}{B} - \frac{p^0}{N}(x_n - z_n) + \\ + \frac{H}{B}(x'_n - z'_n) = \\ = P(x_n, \hat{\mathbf{y}}_{-n}, x'_n, \mathbf{V}_{-n}) - P(z_n, \hat{\mathbf{y}}_{-n}, z'_n, \mathbf{V}_{-n}) \quad (13)$$

■