



HAL
open science

Russian Style (Lack of) Randomness

Léo Perrin

► **To cite this version:**

| Léo Perrin. Russian Style (Lack of) Randomness. 2019. hal-02396756

HAL Id: hal-02396756

<https://inria.hal.science/hal-02396756>

Preprint submitted on 6 Dec 2019

HAL is a multi-disciplinary open access archive for the deposit and dissemination of scientific research documents, whether they are published or not. The documents may come from teaching and research institutions in France or abroad, or from public or private research centers.

L'archive ouverte pluridisciplinaire **HAL**, est destinée au dépôt et à la diffusion de documents scientifiques de niveau recherche, publiés ou non, émanant des établissements d'enseignement et de recherche français ou étrangers, des laboratoires publics ou privés.

Russian Style (Lack of) Randomness

Léo Perrin

Based on joint works with **A. Biryukov** (uni.lu), **X. Bonnetain** (SECRET), **A. Udovenko** (uni.lu), and **S. Tian** (SECRET+China)

September 11, 2019



No secret structure was enforced during construction of the S-box. At the same time, it is obvious that for any transformation a lot of representations are possible (see, for example, a lot of AES S-box representations).

VS.

$$\mathcal{I}_{\kappa,S} : \begin{cases} \mathbb{F}_{2^8} & \rightarrow \mathbb{F}_{2^8} \\ 0 & \mapsto \kappa(0), \\ (\alpha^{2^m+1})^j & \mapsto \kappa(2^m - j), \text{ for } 1 \leq j \leq 2^m - 1, \\ \alpha^{j+(2^m+1)j} & \mapsto \kappa(2^m - i) \oplus (\alpha^{2^m+1})^{s(j)}, \text{ for } 0 < i, 0 \leq j < 2^m - 1. \end{cases}$$

Outline

- 1 Standards and S-boxes
- 2 Reverse-Engineering the Russian S-box
- 3 A Better Understanding of this S-box
- 4 Conclusion

Outline

- 1 Standards and S-boxes
 - Two Russian Standards
 - S-Boxes
- 2 Reverse-Engineering the Russian S-box
- 3 A Better Understanding of this S-box
- 4 Conclusion

Kuznyechik/Streebog

Streebog

Type Hash function

Publication 2012

Kuznyechik

Type Block cipher

Publication 2015



Kuznyechik/Streebog

Streebog

Type Hash function

Publication 2012

Kuznyechik

Type Block cipher

Publication 2015



Common ground

- Both are standard symmetric primitives in Russia.
- Both were designed by the FSB (TC26).
- Both use the same 8×8 S-Box, Π .

S-Boxes

Definition (S(ubstitution)-box)

An S-box $S : \mathbb{F}_2^n \rightarrow \mathbb{F}_2^n$ is a small **non-linear** function operating on a small block size (typically $n \in \{4, 8\}$) which **can** be specified via its lookup table.

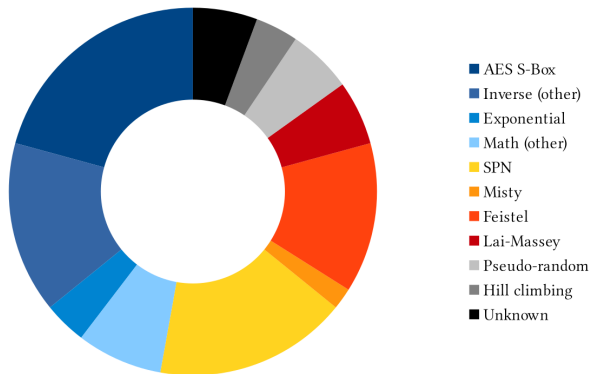

Cryptographic strength vs. Implementation efficiency

The Russian S-box

$\pi' = (252, 238, 221, 17, 207, 110, 49, 22, 251, 196, 250, 218, 35, 197, 4, 77, 233, 119, 240, 219, 147, 46, 153, 186, 23, 54, 241, 187, 20, 205, 95, 193, 249, 24, 101, 90, 226, 92, 239, 33, 129, 28, 60, 66, 139, 1, 142, 79, 5, 132, 2, 174, 227, 106, 143, 160, 6, 11, 237, 152, 127, 212, 211, 31, 235, 52, 44, 81, 234, 200, 72, 171, 242, 42, 104, 162, 253, 58, 206, 204, 181, 112, 14, 86, 8, 12, 118, 18, 191, 114, 19, 71, 156, 183, 93, 135, 21, 161, 150, 41, 16, 123, 154, 199, 243, 145, 120, 111, 157, 158, 178, 177, 50, 117, 25, 61, 255, 53, 138, 126, 109, 84, 198, 128, 195, 189, 13, 87, 223, 245, 36, 169, 62, 168, 67, 201, 215, 121, 214, 246, 124, 34, 185, 3, 224, 15, 236, 222, 122, 148, 176, 188, 220, 232, 40, 80, 78, 51, 10, 74, 167, 151, 96, 115, 30, 0, 98, 68, 26, 184, 56, 130, 100, 159, 38, 65, 173, 69, 70, 146, 39, 94, 85, 47, 140, 163, 165, 125, 105, 213, 149, 59, 7, 88, 179, 64, 134, 172, 29, 247, 48, 55, 107, 228, 136, 217, 231, 137, 225, 27, 131, 73, 76, 63, 248, 254, 141, 83, 170, 144, 202, 216, 133, 97, 32, 113, 103, 164, 45, 43, 9, 91, 203, 155, 37, 208, 190, 229, 108, 82, 89, 166, 116, 210, 230, 244, 180, 192, 209, 102, 175, 194, 57, 75, 99, 182).$

*Screen capture of the specification of **Kuznyechik** (2015).*

Why we need S-box reverse-engineering

The security of a cipher hinges on its S-box: we **need** to know how it works!

Outline

- 1 Standards and S-boxes
- 2 Reverse-Engineering the Russian S-box
 - Jackson Pollock
 - TU-Decomposition
 - The TKlog
- 3 A Better Understanding of this S-box
- 4 Conclusion

A Key Tool for Analysing S-Boxes

Linear Approximations Table (LAT)

The LAT of $S : \{0, 1\}^n \rightarrow \{0, 1\}^n$ is a $2^n \times 2^n$ matrix such that

$$\begin{aligned} \text{LAT}_S[a, b] &= \sum_{x \in \mathbb{F}_2^n} (-1)^{a \cdot x \oplus b \cdot S(x)} \\ &= 2 \times (\#\{x \in \mathbb{F}_2^n, a \cdot x = b \cdot S(x)\}) - 2^n. \end{aligned}$$

¹Biryukov, Perrin. *On reverse-engineering S-Boxes with hidden design criteria or structure*. CRYPTO'15

A Key Tool for Analysing S-Boxes

Linear Approximations Table (LAT)

The LAT of $S : \{0, 1\}^n \rightarrow \{0, 1\}^n$ is a $2^n \times 2^n$ matrix such that

$$\begin{aligned} \text{LAT}_S[a, b] &= \sum_{x \in \mathbb{F}_2^n} (-1)^{a \cdot x \oplus b \cdot S(x)} \\ &= 2 \times (\#\{x \in \mathbb{F}_2^n, a \cdot x = b \cdot S(x)\}) - 2^n. \end{aligned}$$

"Jackson Pollock" Representation¹

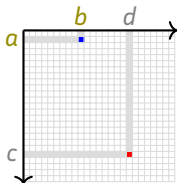

$$|\text{LAT}_S[a, b]| = 0$$

$$|\text{LAT}_S[c, d]| \geq 20$$

¹Biryukov, Perrin. *On reverse-engineering S-Boxes with hidden design criteria or structure*. CRYPTO'15

The LAT of π

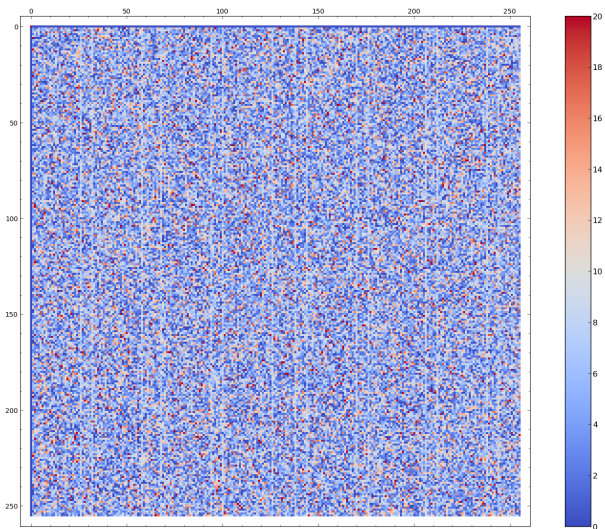

The LAT of π

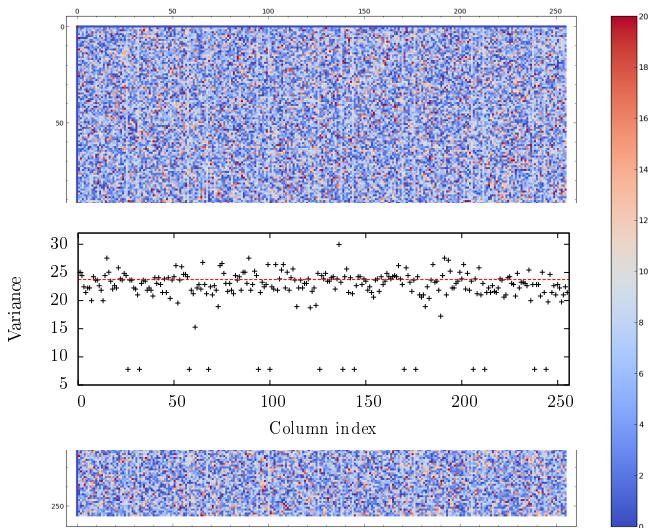

The LAT of π (reordered columns)

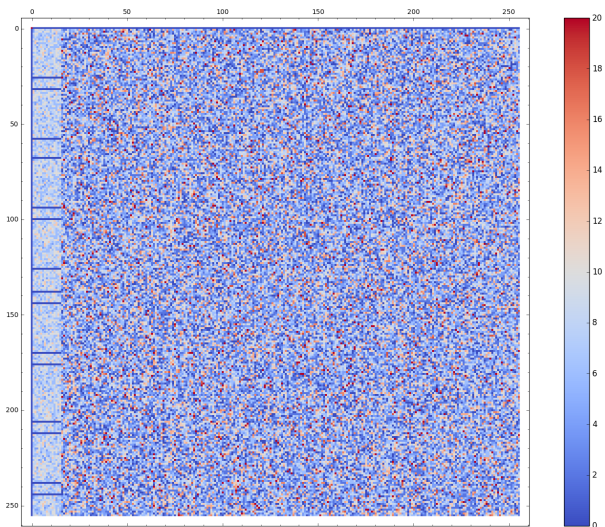

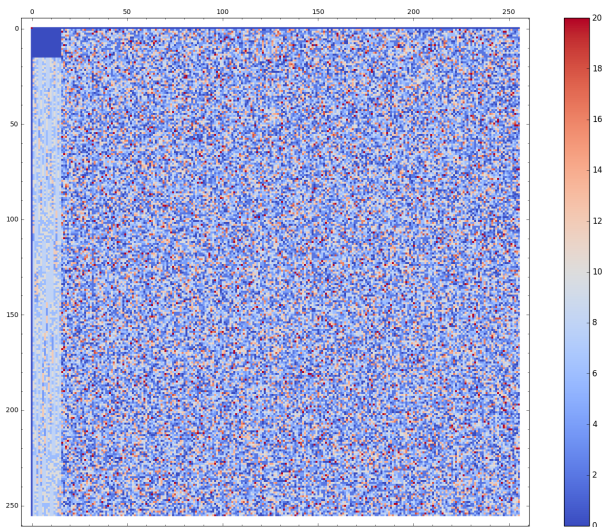
The LAT of $l_2 \circ \pi \circ l_1$ 

First Complete Decomposition of π

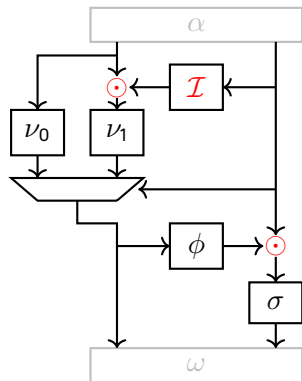

\odot Multiplication in \mathbb{F}_{2^4}

\mathcal{I} Inversion in \mathbb{F}_{2^4}

ν_0, ν_1, σ 4×4 permutations

ϕ 4×4 function

α, ω Linear permutations

Conclusion for Kuznyechik/Streebog?

The Russian S-Box was built like a strange Feistel...

²L. Perrin, A. Udovenko. *Exponential S-boxes: a link between the S-boxes of BelT and Kuznyechik/Streebog*. IACR ToSC. 2016.

Conclusion for Kuznyechik/Streebog?

The Russian S-Box was built like a
strange Feistel...

... or was it?

²L. Perrin, A. Udovenko. *Exponential S-boxes: a link between the S-boxes of BelT and Kuznyechik/Streebog*. IACR ToSC. 2016.

Conclusion for Kuznyechik/Streebog?

The Russian S-Box was built like a
strange Feistel...

... or was it?

Belarussian inspiration

- The last standard of Belarus (BelT) uses an 8-bit S-box,
- somewhat similar to π ...
- ... based on a **finite field exponential!**
- We deduced another decomposition² but not a satisfactory one.

²L. Perrin, A. Udovenko. *Exponential S-boxes: a link between the S-boxes of BelT and Kuznyechik/Streebog*. IACR ToSC. 2016.

Timeline

July 2012 GOST standardization of Streebog

Aug. 2013 RFC for Streebog (RFC6986)

June 2015 GOST standardization of Kuznyechik

Mar. 2016 RFC for Kuznyechik (RFC7801)

Timeline

July 2012 GOST standardization of Streebog

Aug. 2013 RFC for Streebog (RFC6986)

June 2015 GOST standardization of Kuznyechik

Mar. 2016 RFC for Kuznyechik (RFC7801)

May 2016 Publication of the first decomposition (TU-decomposition)

Feb 2017 Publication of the second decomposition (Belarus-like)

Timeline

- July 2012 GOST standardization of Streebog
- Aug. 2013 RFC for Streebog (RFC6986)
- June 2015 GOST standardization of Kuznyechik
- Mar. 2016 RFC for Kuznyechik (RFC7801)
- May 2016 Publication of the first decomposition (TU-decomposition)
- Feb 2017 Publication of the second decomposition (Belarus-like)
- Oct. 2018 ISO standardization of Streebog (ISO 10118-3)

A Third and Final Decomposition: the TKlog

π is a TKlog!

A TKlog operates on $\mathbb{F}_{2^{2m}}$ and uses:

- α : a generator of $\mathbb{F}_{2^{2m}}$,
- κ : an affine function $\mathbb{F}_2^m \rightarrow \mathbb{F}_{2^{2m}}$ with $\kappa(\mathbb{F}_2^m) \oplus \mathbb{F}_{2^m} = \mathbb{F}_{2^{2m}}$,
- s : a permutation of $\mathbb{Z}/(2^m - 1)\mathbb{Z}$.

The corresponding TKlog is denoted $\mathcal{T}_{\kappa,s}$ and it works as follows:

$$\begin{cases} \mathcal{T}_{\kappa,s}(0) & = \kappa(0), \\ \mathcal{T}_{\kappa,s}((\alpha^{2^m+1})^j) & = \kappa(2^m - j), \text{ for } 1 \leq j \leq 2^m - 1, \\ \mathcal{T}_{\kappa,s}(\alpha^{i+(2^m+1)j}) & = \kappa(2^m - i) \oplus (\alpha^{2^m+1})^{s(j)}, \text{ for } 0 < i, 0 \leq j < 2^m - 1. \end{cases}$$

Cosets to Cosets

Russia's π

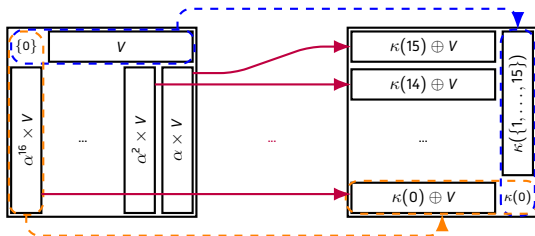

Backdoored S-box

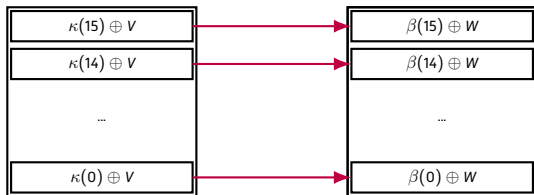

Outline

- 1 Standards and S-boxes
- 2 Reverse-Engineering the Russian S-box
- 3 A Better Understanding of this S-box**
 - Generation Process
 - Anomalies
 - The Kolmogorov Anomaly
- 4 Conclusion

From the Designers, at ISO

questioned is the S-box π . This S-box was chosen from Streebog hash-function and it was synthesized in 2007. Note that through many years of cryptanalysis no weakness of this S-box was found. The S-box π was obtained by pseudo-random search and the following properties were taken into account.

[...]

No secret structure was enforced during construction of the S-box. At the same time, it is obvious that for any transformation a lot of representations are possible (see, for example, a lot of AES S-box representations).

From the Designers, at ISO

questioned is the S-box π . This S-box was chosen from Streebog hash-function and it was synthesized in 2007. Note that through many years of cryptanalysis no weakness of this S-box was found. The S-box π was obtained by pseudo-random search and the following properties were taken into account.

[...]

No secret structure was enforced during construction of the S-box. At the same time, it is obvious that for any transformation a lot of representations are possible (see, for example, a lot of AES S-box representations).

Everything is wrong (except for the AES bit).

A Key Concept: "Anomalies" (1/2)

How "far" is the behaviour of a specific S-box π from that of a "random S-box"?

A Key Concept: "Anomalies" (1/2)

How "far" is the behaviour of a specific S-box π from that of a "random S-box"?

First idea

What is the probability of a specific property of the S-box?

A Key Concept: "Anomalies" (1/2)

How "far" is the behaviour of a specific S-box π from that of a "random S-box"?

First idea

What is the probability of a specific property of the S-box?

Does not work!

The properties we consider are not intended for that purpose.

- $\Pr [\text{Differential uniformity} = 8] \approx 2^{-16.15} \approx (72000)^{-1}$
- $\Pr [\text{Differential uniformity} = 6] \approx 2^{-164.5} \approx (3 \cdot 10^{49})^{-1}$

A Key Concept: "Anomalies" (2/2)

- 1 Choose a **finer grained property** (LAT max/# occurrences of the max, implementation complexity...) with a value in a partially ordered set (i.e. a number)



A Key Concept: "Anomalies" (2/2)

- 1 Choose a **finer grained property** (LAT max/# occurrences of the max, implementation complexity...) with a value in a partially ordered set (i.e. a number)
- 2 Compute it for the specific target



A Key Concept: "Anomalies" (2/2)

- 1 Choose a **finer grained property** (LAT max/# occurrences of the max, implementation complexity...) with a value in a partially ordered set (i.e. a number)
- 2 Compute it for the specific target
- 3 Evaluate the number S-boxes with with a **worse** and a **better** property



A Key Concept: "Anomalies" (2/2)

- 1 Choose a **finer grained property** (LAT max/# occurrences of the max, implementation complexity...) with a value in a partially ordered set (i.e. a number)
- 2 Compute it for the specific target
- 3 Evaluate the number S-boxes with with a **worse** and a **better** property



Negative Anomaly

$$\bar{\mathcal{A}}(\pi) = -\log_2 \left(\frac{\text{\#worse S-boxes}}{(2^n)!} \right)$$

Negative Anomaly

$$\mathcal{A}(\pi) = -\log_2 \left(\frac{\text{\#better S-boxes}}{(2^n)!} \right)$$

Some Very High Anomalies

Informally (more details at AC'19³), a high **positive anomaly** for a **property** means:

- a *random* S-box is unlikely to have a **property** “at least as pronounced” as π ;
- we need to generate about 2^A random S-boxes to get one where the **property** is this strong.

³*Anomalies and Vector Space Search: Tools for S-Box Analysis*. ASIACRYPT'19. X. Bonnetain, L. Perrin and S. Tian.

Some Very High Anomalies

Informally (more details at AC'19³), a high **positive anomaly** for a **property** means:

- a *random* S-box is unlikely to have a **property** “at least as pronounced” as π ;
- we need to generate about 2^A random S-boxes to get one where the **property** is this strong.

Anomalies of π .

Statistical			Structural	
Differential	Linear	Boomerang	TU ₄	TKlog
80.6 [†]	34.4	14.2	201.1	1601.5

[†] This anomaly might be overestimated.

³*Anomalies and Vector Space Search: Tools for S-Box Analysis*. ASIACRYPT'19. X. Bonnetain, L. Perrin and S. Tian.

Kolmogorov Anomaly (2/2)

The “Shannon effect”:⁴

“almost all functions” of n arguments have “an almost identical” complexity which is asymptotically equal to the complexity of the most complex function of n arguments.

Indeed, specific structures (TKlog, TU-decompositions...) have a very high anomaly...

⁴On Networks Consisting of Functional Elements with Delays. Lupanov, O.B. 1973.

Kolmogorov Anomaly (2/2)

The “**Shannon effect**”:⁴

“almost all functions” of n arguments have “an almost identical” complexity which is asymptotically equal to the complexity of the most complex function of n arguments.

Indeed, specific structures (TKlog, TU-decompositions...) have a very high anomaly...

... but not *really* an anomaly. Can we do better?

⁴*On Networks Consisting of Functional Elements with Delays.* Lupanov, O.B. 1973.

Kolmogorov Anomaly (2/2)

```
p(x){unsigned char*k="@`rFTDVbpPB
vdtfR@\xacp?\xe2>4\xa6\xe9{z\xe3q
5\xa7\xe8",a=2,l=0,b=17;while(x&&
(l++,a^x))a=2*a^a/128*29;return l
%b?k[l%b]^k[b+l/b]^b:k[l/b]^188;}
```

165 ASCII characters that fit on 7 bits: this program is 1155-bit long.

<https://codegolf.stackexchange.com/questions/186498/>

proving-that-a-russian-cryptographic-standard-is-too-structured

Kolmogorov Anomaly of π

The probability that a random 8-bit S-box is as structured as π is at most equal to

$$2^{1155-1684} = 2^{-529}.$$

Outline

- 1 Standards and S-boxes
- 2 Reverse-Engineering the Russian S-box
- 3 A Better Understanding of this S-box
- 4 Conclusion**

Conclusion

No secret structure was enforced during construction of the S-box. At the same time, it is obvious that for any transformation a lot of representations are possible (see, for example, a lot of AES S-box representations).

vs.

```
p(x){unsigned char*k="@`rFTDVbpPB
vdtfRQ\xacp?\xe2>4\xa6\xe9{z\xe3q
5\xa7\xe8",a=2,l=0,b=17;while(x&&
(l++,a^x))a=2*a^a/128*29;return l
zb?k[l/b]^k[b+l/b]^b:k[l/b]^188;}
```

- This claim and this fact **cannot** be reconciled.

Conclusion

No secret structure was enforced during construction of the S-box. At the same time, it is obvious that for any transformation a lot of representations are possible (see, for example, a lot of AES S-box representations).

vs.

```
p(x){unsigned char*k=@"rFTDVbpPB
vdtfRQ\xacp?\xe2>4\xa6\xe9{z\xe3q
5\xa7\xe8",a=2,l=0,b=17;while(x&&
(l++,a^x))a=2*a^a/128*29;return l
zb?k[l:b]^k[b+l/b]^b:k[l/b]^188;}
```

- This claim and this fact **cannot** be reconciled.
- In my opinion, the designers of these algorithms **have provided misleading information** for the external analysis of their design.

Conclusion

No secret structure was enforced during construction of the S-box. At the same time, it is obvious that for any transformation a lot of representations are possible (see, for example, a lot of AES S-box representations).

vs.

```
p(x){unsigned char*k="@`rFTDVbpPB
vdtfRQ\xacp?\xe2>4\xa6\xe9{z\xe3q
5\xa7\xe8",a=2,l=0,b=17;while(x&&
(l++,a^x))a=2*a^a/128*29;return l
zb?k[l:b]^k[b+l/b]^b:k[l/b]^188;}
```

- This claim and this fact **cannot** be reconciled.
- In my opinion, the designers of these algorithms **have provided misleading information** for the external analysis of their design.
- Security analysis is hard enough with proper information: **there is no good reason** to complicate it further with wrong data!

Conclusion

No secret structure was enforced during construction of the S-box. At the same time, it is obvious that for any transformation a lot of representations are possible (see, for example, a lot of AES S-box representations).

vs. `p(x){unsigned char*k=@"rFTDVbpPB
vdtfRQ\xacp?\xe2>4\xa6\xe9{z\xe3q
5\xa7\xe8",a=2,l=0,b=17;while(x&&
(l++,a^x))a=2*a^a/128*29;return l
z;b?k[l:b]^k[b+l/b]^b:k[l/b]^188;}`

- This claim and this fact **cannot** be reconciled.
- In my opinion, the designers of these algorithms **have provided misleading information** for the external analysis of their design.
- Security analysis is hard enough with proper information: **there is no good reason** to complicate it further with wrong data!

⇒ These algorithms **cannot be trusted** and
I believe they should be deprecated.

Conclusion

No secret structure was enforced during construction of the S-box. At the same time, it is obvious that for any transformation a lot of representations are possible (see, for example, a lot of AES S-box representations).

vs. `p(x){unsigned char*k="@`rFTDVbpPB
vdtfRQ\xacp?\xe2>4\xa6\xe9{z\xe3q
5\xa7\xe8",a=2,l=0,b=17;while(x&&
(l++,a^x))a=2*a^a/128*29;return l
zb?k[l:b]^k[b+l/b]^b:k[l/b]^188;}`

- This claim and this fact **cannot** be reconciled.
- In my opinion, the designers of these algorithms **have provided misleading information** for the external analysis of their design.
- Security analysis is hard enough with proper information: **there is no good reason** to complicate it further with wrong data!

⇒ These algorithms **cannot be trusted** and
I believe they should be deprecated.

Thank you!