



HAL
open science

Automatic generation of Truffle-based interpreters for Domain-Specific Languages

Manuel Leduc, Gwendal Jouneaux, Thomas Degueule, Gervan Le Guernic,
Olivier Barais, Benoit Combemale

► **To cite this version:**

Manuel Leduc, Gwendal Jouneaux, Thomas Degueule, Gervan Le Guernic, Olivier Barais, et al.. Automatic generation of Truffle-based interpreters for Domain-Specific Languages. *The Journal of Object Technology*, 2020, 19 (2), pp.1-21. 10.5381/jot.2020.19.2.a1 . hal-02395867v1

HAL Id: hal-02395867

<https://inria.hal.science/hal-02395867v1>

Submitted on 5 Dec 2019 (v1), last revised 21 Feb 2021 (v2)

HAL is a multi-disciplinary open access archive for the deposit and dissemination of scientific research documents, whether they are published or not. The documents may come from teaching and research institutions in France or abroad, or from public or private research centers.

L'archive ouverte pluridisciplinaire **HAL**, est destinée au dépôt et à la diffusion de documents scientifiques de niveau recherche, publiés ou non, émanant des établissements d'enseignement et de recherche français ou étrangers, des laboratoires publics ou privés.

Automatic generation of Truffle-based interpreters for Domain-Specific Languages

Manuel Leduc¹, Gwendal Jouneaux¹, Thomas Degueule³, Gurvan Le Guernic², Olivier Barais¹, and Benoit Combemale^{1,4}

¹Univ. Rennes, Inria, CNRS, IRISA

²DGA, Bruz, France

³CWI, Amsterdam, The Netherlands

⁴Univ. Toulouse, IRIT

December 5, 2019

Abstract

Numerous language workbenches have been proposed over the past decade to ease the definition of Domain-Specific Languages (DSLs). Language workbenches enable language designers to specify DSLs using high-level metalanguages and to generate their implementation (e.g., parsers, interpreters) and tool support (e.g., editors, debuggers) automatically. However, little attention has been given to the performance of the resulting interpreters. In many domains where performance is key (e.g., scientific and high-performance computing), this forces language designer to hand-craft ad-hoc optimizations in the interpreter implementations, or to lose compatibility with tool support.

In this paper, we propose to systematically exploit the domain-specific information of language specifications to derive optimized Truffle-based language interpreters executed over the GraalVM. We implement our approach on top of the Eclipse Modeling Framework (EMF) by complementing its existing compilation chain with Truffle-specific information, which drives the GraalVM to benefit from an optimized just-in-time compilation. A key benefit of our approach is that it leverages existing language specifications and does not require additional information from language designers who remain oblivious of Truffle’s low-level intricacies and JIT optimizations in general while staying compatible with tool support.

We evaluate our approach using a representative set of four DSLs and eight conforming programs. Compared to the standard interpreters generated by EMF running on the GraalVM, we observe an average speed-up of x1.14, ranging from x1.07 to x1.26. Although the benefits vary slightly from one DSL or program to another, we conclude that our approach yields substantial performance gains while remaining non-intrusive of EMF abstractions.

domain-specific language; metalanguages; interpreters; just-in-time optimizations

1 Introduction

Numerous language workbenches [EVDSV⁺15] have been proposed over the past decade to ease the development of Domain-Specific Languages (DSLs). The main objective is to support domain experts by reifying concepts dedicated to a given application domain to ease the development of future complex systems in this particular domain. Language workbenches provide dedicated metalanguages to specify the various concerns of a DSL (e.g., abstract syntax, concrete syntax, and semantics), together with generative or generic approaches that automate the production of language tooling, including editors, compilers, interpreters, and analysis tools. Among others, we can cite industrial language workbenches such as MetaEdit+ [TR03], MPS [Voe11], EMF [SBMP08], or academic projects such as Rascal [BvdBH⁺15], Spoofox [KV10], Neverlang [VC15] or the GEMOC Studio [BDV⁺16].

By their very nature, generative and generic approaches hamper the incorporation of language-specific optimizations, making the resulting language runtimes much less efficient than the optimized runtimes of general-purpose languages (e.g., just-in-time (JIT) compilation in the current JDK or V8 JS engine). Indeed, DSL runtime generators apply the same generic generation pattern for every DSL. Different generators may apply different patterns, but a given generator always applies the same pattern, which prevents specific optimizations tailored to the specificities of a particular application domain. For instance, EMF derives a visitor-like Java class based on runtime-type inspection from a metamodel.

Recently, various frameworks have been proposed to support the definition of languages over the JVM and assist in the optimization of the JIT compiler – a compiler that transforms part of program code to machine code during its execution – of the resulting interpreters. Truffle [WW12] relies on the Partial Evaluation capabilities provided by the GraalVM [Ora19] to realize such language interpreter optimizations. Truffle offers facilities to complement an initial DSL interpreter implementation with patterns and annotations to benefit from specific runtime optimizations. Performance gains reported in the literature are significant [WWH⁺17]. However, efficiently using these frameworks requires strong expertise in language development and the intricacies of the framework itself.

In this paper, we aim to leverage on the high-level abstractions provided by metalanguages and language workbenches on the one side, to abstract the low-level intricacies of interpreter optimization on the other side. In addition, we do so without breaking the compatibility with other tools surrounding the DSLs (e.g., editors, debuggers). We introduce a systematic approach to generate optimized Truffle-based language interpreters from model-based DSLs specifications automatically, inducing a complementary speedup on top of language interpreters based on the Interpreter pattern. Our systematic approach exploits

high-level information contained in language specifications to drive the application of Truffle-based optimizations. We also propose an implementation of our approach integrated with the compilation chain of EMF, enabling its application to many already existing and future DSLs.

In summary, we propose and evaluate a non-intrusive approach to the optimization of model-based interpreter performances.

We evaluate our approach on a representative set of four languages and eight conforming programs (from programming languages to modeling languages to “end-user” languages, from arithmetic-intensive to structure-intensive, from recursive style to iterative style). Our experiments demonstrate the benefits of our approach in all cases. The average speedup is of x1.14, ranging from x1.07 to x1.26.

To summarize, the approach proposed in this paper enables language designers to automatically obtain efficient language interpreters while remaining oblivious of the technical details of the interpreter optimizations.

The remainder of this paper is organized as follows. ?? introduces useful preliminary notions. ?? presents the language design and implementation patterns studied in the remainder of this paper. ?? gives an overview of our approach and presents the Truffle optimizations applicable in our context. ?? presents our implementation choices. ?? evaluates the resulting tools and metalanguages on several languages and programs. Finally, ?? relates our approach to existing work, and ?? concludes and presents potential future work.

2 Background

In this section, we discuss the background on language specification using the Eclipse Modeling Framework (EMF) and the Action Language for Ecore (ALE). Then we discuss the background on language execution and implementation using GraalVM and Truffle.

2.1 Eclipse Modeling Framework

The Eclipse Modeling Framework (EMF) [SBMP08] is an implementation aligned with the Meta-Object Facility (MOF) [OMG06], a standard for the definition of models and metamodels. EMF integrates Ecore, an industrial-grade metamodeling language and de-facto standard, well known in the modeling community. Consequently, many tools are provided to manipulate Ecore metamodels (i.e., tree-based, textual¹, or graphical² editors). This compatibility with a wide range of tools is a key aspect of EMF, and we aim at preserving it while improving language performances. Ecore metamodels are compiled to Java code that implements the Ecore concepts presented below. Our contribution extends the compilation chain of EMF to provide additional performance gain of EMF-based language interpreter.

¹Xcore: <https://wiki.eclipse.org/Xcore>

²EcoreTools: <https://www.eclipse.org/ecoretools/>

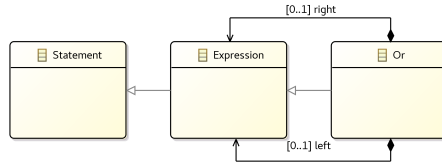

Figure 1: A sample of MiniJava metamodel using Ecore

MiniJava is a teaching-oriented subset of Java [Rob01]. We use MiniJava as an illustration in this section, and later in our evaluations. ?? presents a sample of MiniJava’s metamodel. Following a popular language abstract syntax pattern, the concept of **Or** inherits from **Expression** which itself inherit from **Statement**. Inheritance relations are visually identifiable by unfilled arrows on the parent side of the relation. The concept of **Or** contains two sub-expressions of type **Expression**, respectively named **left** and **right**. Sub-expressions are defined using containment relations – conceptually equivalent to UML’s composition relations [UML05] – and are visually identifiable by black diamonds at the start of the relation.

Ecore provides the expressiveness needed to express object-oriented abstract syntaxes. However, Ecore does not provide useful abstractions for the definition of language execution semantics. ALE, presented in the next section, allows the modular definition of operational semantics on top of Ecore-based abstract syntaxes.

2.2 Action Language for Ecore

Action Language for Ecore (ALE) is a metalanguage dedicated to the definition of language execution semantics. Inspired by Kermeta [JCB⁺15], ALE is statically typed. Besides, ALE supports the type-inference of its expressions. ALE is based on the “open-class” principle [CLCM00], allowing the modular definition of semantics on top of existing metamodels. ?? presents a sample of the implementation of an execution semantics, in the form of an interpreter on top of the metamodel of MiniJava presented in ??. The **Or** class re-opens the concept of **Or** defined in ?? and adds an **evaluateExpression** method. The result of the method is obtained by evaluating the **left** and **right** sub-expressions (lines 16 and 17 of ??) and applying the logical OR operation on the results (?). Finally, the result of the evaluation of the logical OR is wrapped in an instance of **BooleanValue** and returned (?). The **:=** operator is used for variable assignment. Inspired by the Eiffel language [Mey92], ALE does not have a **return** keyword, but the content of the **result** variable is returned. Class instantiation is done using the special **create()** method (?). Extensions are possible thanks to the mechanism of services inspired by the extension method mechanism [EEK⁺12]. Lines 1 and 20 are respectively the import of an ALE logging service and the call to the **log** method provided by the service. An ALE

Listing 1: Sample of the operational semantics of MiniJava in ALE.

```
1 use miniJava.LogService;
2
3 open class Statement {
4   def dispatch void evaluateStatement(State state) {}
5 }
6
7 open class Expression {
8   def void evaluateStatement(State state) {
9     self.evaluateExpression(state);
10  }
11  def Value evaluateExpression(State state) {}
12 }
13
14 open class Or {
15   def Value evaluateExpression(State state) {
16     BooleanValue left := self.left.evaluateExpression(state);
17     BooleanValue right := self.right.evaluateExpression(state);
18     BooleanValue res := miniJava::BooleanValue.create();
19     res.value := left.isValue() or right.isValue();
20     res.value.log("INFO");
21     result := res;
22   }
23 }
```

service is a Java class with static methods, and aims at providing methods to solve problems outside the scope of the domain of the language (e.g., logging, user interfaces, database access).

EMF and ALE are seamlessly integrated into the Eclipse IDE and support language engineers in the specification of DSLs, following a standard object-oriented approach.

2.3 GraalVM

GraalVM is a JVM resulting from an internal project of Oracle [WWW⁺13] and has shown promising performance improvement results. GraalVM is a universal virtual machine targeting the execution of arbitrary languages (e.g., JavaScript, Python, Ruby, R, or LLVM). It includes a new high-performance JIT compiler, called Graal, which produces native code from Java bytecode. It is used as a replacement for the JIT of the HotSpot VM in GraalVM. Graal is also used as an ahead-of-time compiler by the Substrate VM³, allowing the compilation of Java bytecode to native machine code outside of a virtual machine.

³Substrate VM documentation: <https://www.graalvm.org/docs/reference-manual/aot-compilation/>

2.4 Truffle

Truffle [WW12] is a framework designed to ease the development of efficient interpreters on the JVM. Several works demonstrate the speedup offered by Truffle-based interpreters [SWHJ16, MDM16]. This makes it interesting to study in the context of DSL performance. Truffle provides a set of classes, annotations, and built-in operations in order to produce efficient Java implementations of interpreters following the Interpreter pattern. The Interpreter pattern is additionally decorated with annotations that assist in the definition of efficient language implementations.

At runtime, Truffle relies on Partial Evaluation [Lom67, Fut99]. This consists of the combination of an interpreter with its program to produce an optimized interpreter, specialized for this given program. While the optimizations are processed by Graal, Truffle provides the expressiveness to define language-level information that assists Graal to apply language-specific optimizations.

In our context, Partial Evaluation works by combining a method of an interpreter with data (i.e., parts of a program) to produce an optimized Graal Intermediate Representation (IR). The Partial Evaluation process allows the application of various optimizations such as constant folding, indirect to direct call substitution, or dead code elimination.

During Partial Evaluation, Truffle can make optimistic assumptions (e.g., a variable is never null, a method always returns true), and propagate such decisions (e.g., removing an unreachable `else` branch) in the resulting optimized machine code. If runtime data later contradict future executions of the optimized code (e.g., the variable is finally not-null), Truffle can *deoptimize* the code and goes back to using the interpreter version of the code.

Without constraints, Truffle explores the execution graph eagerly during Partial Evaluation. Consequently, this process might lead to code explosion [WWH⁺17], failing due to the production of too large specialized interpreters (i.e., too large to be compiled). This is why Truffle requires the definition of explicit boundaries in order to prevent such undesirable behaviors. Würthinger et al. [WWH⁺17] shared their experience building interpreters with Truffle. They tried to define boundaries automatically but did not find a suitable automated solution in the context of the abstraction proposed by Java.

3 DSL Design and Implementation

The definition of a DSL encompasses the definition of its abstract syntax and semantics. The abstract syntax specifies the domain concepts and their relations. In the modeling world, it is typically defined by a metamodel. Object-Oriented formalisms such as Ecore, presented in ??, represents language concepts as a set of metaclasses and their relations. The semantics of a DSL assign meaning to its constructs. In order to support the operational execution of the conforming models, it is typically defined by an interpreter. It implements its operational semantics in the form of transition function over model states. In the modeling

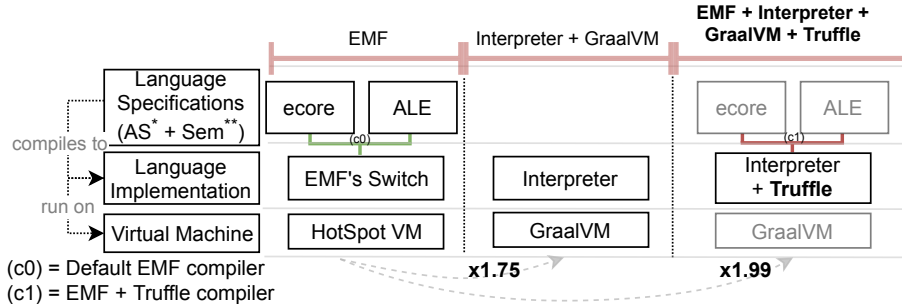

Figure 2: General overview of the proposed approach. Decimal numbers prefixed with an x represent performance speedups. * Abstract Syntax. ** Semantics.

world, it is defined using an action language that extends the language concepts with operations. In this paper, we use ALE, presented in ??.

The operational semantics defines the evolution of the state of the execution of a program. This evolution is realized by the modification of the metamodel by the operational semantics at runtime. The set of concepts modified during the execution is called the *Execution metamodel* [BDV⁺16].

One solution to make metamodels and operational semantics executable is to compile them to general-purpose languages. In this context, their implementations follow well-defined implementation patterns [OC12, VRCG⁺99, EG01, WWS⁺12, ACL⁺98].

The most common being the Interpreter and Visitor patterns [GHJV95]. While functionally equivalent, both pattern offers different advantages, notably regarding their modularity, but also regarding their performances. By default, EMF provides the generation of a variation of the Visitor pattern, named the Switch pattern. Consequently, this implementation pattern is found in EMF-based language implementations and is used as a reference in this paper.

In the remainder of this paper, we study our approach to improve further the performances of the implementation of languages specified using model-oriented language specifications, as presented in this section.

4 Approach Overview

This section presents a general overview of our approach and presents the optimizations that can be derived from the abstraction provided by metalanguage in the context of the approach to language specification presented in the previous section.

Our approach and its context are illustrated in ?. The first column presents the state of practice of language interpreter implementation using the standard EMF Switch pattern for the language interpreter implementations and uses HotSpot VM for the program’s execution. Then, the second column presents a

Table 1: Average speedups resulting from the transition from HotSpot VM to GraalVM and from the Switch implementation pattern to the Interpreter implementation pattern.

	HotSpot VM	GraalVM
Switch pattern	x1.00	x1.65
Interpreter pattern	x1.23	x1.75

solution that substitutes the Switch for the Interpreter implementation pattern and uses GraalVM for the program’s execution. This column exploits state of the practice solutions exclusively but already provides performance speedup and helps to position our approach. Finally, the third column presents our contribution and introduces a new EMF to Java compiler, allowing the automated introduction of Truffle optimizations while staying compatible with existing EMF implementation patterns. This way, language engineers benefit from performance optimization allowed by Truffle without having to be exposed to its technical details.

In ??, we present some preliminary results that help understand the scope of our approach, corresponding to the transition from the first to the second column. Then, ?? presents the metamodels generation while complying with the constraints of Truffle, and ?? presents the automatic introduction of Truffle boundaries. Finally, ?? details the aspects of Truffle that are not included in our approach.

4.1 Preliminary Results

The choice of runtime and implementation pattern for model-based DSLs is composed of HotSpot VM and the Switch implementation pattern. As we target GraalVM and the Interpreter implementation pattern, we first investigate the impact of the transition to the latter. Even if this is not strictly part of our contribution, it is still useful to have an estimation of the expected speedup of such design decisions.

?? summarizes the impact of the transitions from HotSpot VM to GraalVM with a speedup of x1.56, from the Switch to Interpreter implementation pattern with a speedup of x1.23, and both combined with a speedup of x1.75. We can observe that each transition, independently, is very beneficial, and even more when combined. The details of these numbers are available in ??.

4.2 Truffle-Compliant Object Model Implementation

Starting from a language implementation based on the Interpreter pattern and running on GraalVM, the next challenge is to translate Ecore metamodels to an object model, in the form of a set of Java classes that can be efficiently optimized by Truffle. Truffle expects Java classes to form an immutable tree-shaped set of classes, whereas Ecore defines graph-based and mutable set of classes. Consequently, the translation from Ecore is not straightforward, and multiple

steps are needed to produce an efficient Truffle compliant implementation.

The first step is the discrimination between the immutable metaclasses, that can be part of Truffle object models, and mutable metaclasses of the Execution metamodel, that cannot. Metaclasses that match this definition can be compiled into Truffle nodes, whereas the others are compiled to standard Java classes.

We proceed to this classification by analysis of the ALE specifications. Metaclasses instantiated using the `create()` operation (i.e., possibly created at runtime) are part of the Execution metamodel, whereas the other metaclasses are part of the Abstract Syntax. Only metaclasses of the later are compiled as Truffle nodes.

Truffle nodes are identified by their inheritance to the `Truffle Node` class. We duplicated the usual EMF class hierarchy in order to create a Truffle specific hierarchy by introducing the `Node` class at the top of the hierarchy. Classes of the Execution metamodel inherits from the standard EMF hierarchy, whereas classes of the Abstract Syntax inherits from the Truffle specific hierarchy.

The second step is the identification of the metaclasses' references that can be translated into Truffle parent-child relation, which defines the tree-shaped hierarchy in the object model. We identified the following constraints i) Metaclasses' references must be containment references; ii) the references must take place between metaclasses that can be translated into Truffle nodes; iii) the reference cannot be mutated during the language execution. References that conform to these three constraints are promoted as parent-child relations.

The identification of the containments is realized by a straightforward analysis of the metamodel. We presented above how Truffle nodes are identified. Finally, the mutability analysis is realized by analyzing the occurrences of field modification operations (e.g., call to setters or modification of collections). If a relation between two metaclasses conforms to the three constraints above, the compiler introduces a parent-child relation.

If the reference has an upper multiplicity of one, parent-child relations are realized by the annotation of the field with the `@Child` annotation. When its upper multiplicity is greater than one, the `@Children` annotation is added to the field, but this introduces an additional constraint on the generated code. Indeed, Truffle constrains the fields annotated with `@Children` to be a Java array, instead of the usual EMF `EList`. Additionally, in order to preserve the compatibility with EMF model loading (i.e., one of EMF's tool support), all the fields derived from references with an upper multiplicity greater than one must be of type `EList`. We satisfy those contradictory constraints by introducing a new field, named after the original reference and suffixed with `Arr`, and typed by an array of elements of the same type as the original reference.

?? shows an example of the resulting compilation for a `Block` class with a `statements` field containing `Statement` objects. This array is initialized the first time one of the methods declared in ALE is called (??), by copying the element from the list to the array (lines 14 and 15). `CompilerDirectives.transferToInterpreterAndInvalidate()` (??) warns Truffle to return to the Java bytecode interpreter because a JIT-compiled machine code would be deprecated (i.e., deoptimized), in case of early Truffle Partial Evaluation.

Listing 2: Integration of the Children annotation on a Block statement.

```
1 @NodeInfo(description="Block")
2 class Block extends Node {
3     private List<Statement> statements;
4     @Children private Statement[] statementsArr;
5
6     public List<Statement> getStatements() {
7         if(statements == null) statements = new ArrayList<>();
8         return statements;
9     }
10
11    public void execute() {
12        if(this.statementsArr == null) {
13            CompilerDirectives.transferToInterpreterAndInvalidate();
14            if(statements != null) statementsArr = statements.toArray(
15                Statement[0]);
16            else statementsArr = new Statement[] {};
17        }
18        // statementsArr is used instead of statements.
19    }
```

4.3 Truffle Boundaries

We explained in ?? the challenge of Truffle boundaries identification. Placing relevant Truffle boundaries is crucial to obtain interesting performance speedups. We can take advantage of our approach based on metalanguages with domain-specific expressiveness and a generic compilation scheme, allowing the safe reification of boundaries in the compiler.

Consequently, we can identify exhaustively the places where boundaries are relevant without the need for advanced heuristics or static analysis, allowing the safe generation of interpreters without risks of Partial Evaluation failure during program interpretation. For instance, the Java sources produced by EMF introduce involved proxy mechanisms to guarantee models consistency (e.g., bidirectional reference, where referential integrity is required), which leads to code explosion when partially evaluated. Hence, they are placed behind Truffle boundaries.

Truffle boundaries are defined by annotating methods with the `@TruffleBoundary` annotation. Boundaries are placed on every method that is not directly derived from ALE specifications. In other words, we isolate the code directly derived from ALE specification, from the code that implicitly supports it. For instance, the call to the classes of the library supporting EMF, or the code indirectly called from it (e.g., the operations of the reflective API of the classes) are placed behind boundaries.

In practice, the code directly derived from ALE specifications is compiled to simple operations that are not subject to code explosion (e.g., accessors, variable affectation, java operators) and isolated from code subject to code explosion.

Listing 3: Extract of an ALE service. Methods are annotated with `@TruffleBoundary` in order to anticipate Partial Evaluation issues at runtime.

```
1 class LogService {
2     @TruffleBoundary
3     static void log(Object self, String level) {
4         if (level.equals("INFO")) { Logger.info(self); }
5         // ...
6     }
7 }
```

4.4 Discussion of Additional Truffle Optimizations

For the approach presented in this paper, we set the constraint to be non-intrusive of language specifications and to preserve the compatibility with the tool support of languages. This section discusses possible performance improvement that could not be considered given such constraints. We first illustrate this idea by presenting the Polymorphic Inline Cache optimization (??), before discussing other optimizations (??).

4.4.1 Polymorphic Inline Cache

Using Truffle allows the definition of Polymorphic Inline Cache (PIC) [HCU91]. PIC is a language optimization historically implemented in the Smalltalk language [DS84] that aims at optimizing dynamically the performance of the call sites frequently dispatched to different methods. Würthinger et al. [WWS⁺12] present the use of PICs for the optimization of Truffle-based language interpreter implementations.

The introduction of the PIC optimization raises the challenge of the automatic identification of the call site that would benefit from such optimization. Indeed, badly placed, PICs can be detrimental to the performances of programs.

In practice, the identification of the methods that benefit from the introduction of PIC optimizations in language implementations is challenging and can even lead to slowdown or runtime errors if done wrong. We tried to identify the relevant uses of PICs in the implementation of languages by benchmarking a large sampling of usage. To do so, we introduced a *dispatch* keyword in ALE, that can be used as a method declaration prefix by language engineers to define the introduction of PICs explicitly.

We proceeded by automatic mutation of the MiniJava object-oriented language presented in ?? to introduce the dispatch keyword on random method declarations. The results of our experiment are available on the paper’s companion webpage⁴. The conclusions of our experiments clearly show that the use of PICs has a strong influence on the performance of the language but did not permit us to infer actionable rules to automate the placement of the PICs.

⁴Companion webpage:
#automated-feature-selection

<https://manuelleduc.github.io/ecmfa-2020/>

The companion webpage⁵ presents additional technical details on the use of Truffle on the implementation of the Polymorphic Inline Cache.

4.4.2 Other Optimizations

Truffle offers a profiling library, allowing the fine-tuning of the interpreter implementation by the introduction of runtime state monitoring at relevant places (e.g., by monitoring the condition of an `if` statement). Placing those profiling probes is highly context-sensitive and requires knowledge that goes beyond the abstractions available in operational semantics specifications. Consequently, using the profiling capabilities of Truffle is outside the scope of our approach.

Truffle also provides loop unrolling capabilities, assisted by specific annotations and classes. To properly exploit loop unrolling requires to be able to estimate the size of the content of a loop. Since programs of DSLs are very diverse in shapes and sizes, it leads to challenges similar to the one raised for the profiling library.

Truffle provides a `Frame` object, that assists in the definition of stack located variables, instead of the heap. `Frame` objects are non-trivial to manipulate as they are sensitive to escape analysis, and cannot, among others, be assigned to fields or be type-casted. The choice of the runtime data that is beneficial to move into frames is context-specific. Consequently, it falls into the same limitations as the optimizations presented above.

Finally, Truffle allows for methods specialization. This technique is the foundation of various Truffle implementation patterns (e.g., type boxing). But it requires to define multiple methods (e.g., `equal0(int,int)`, `equal1(String,String)`) for a single operation (e.g., here, the equality of the values returned by two child nodes). The relevant method is called by inspection of the type of the value returned by the child nodes. This multiplication of methods breaks the public interface of the classes, hence making it possibly incompatible with the surrounding tool support.

5 Implementation

On the left of ??, we present the existing Ecore to Java compiler provided as part of the EMF framework, based on the Jet template engine [SBMP08]. This compiler allows the generation of Java object models that conform to Ecore semantics and comes with a mechanism to support the re-generation of Java source from an updated Ecore metamodel while preserving code manually introduced previously in the generated code. This is the base mechanism to follow the Interpreter pattern using EMF.

On the right of the figure, we present our Ecore + ALE compiler that conceptually extends EMF's compiler by supporting the modular introduction of operations on top of Ecore metamodels using ALE. Our initial prototype was

⁵Companion webpage: <https://manuelleduc.github.io/ecmfa-2020/#polymorphic-inline-cache-implementation>

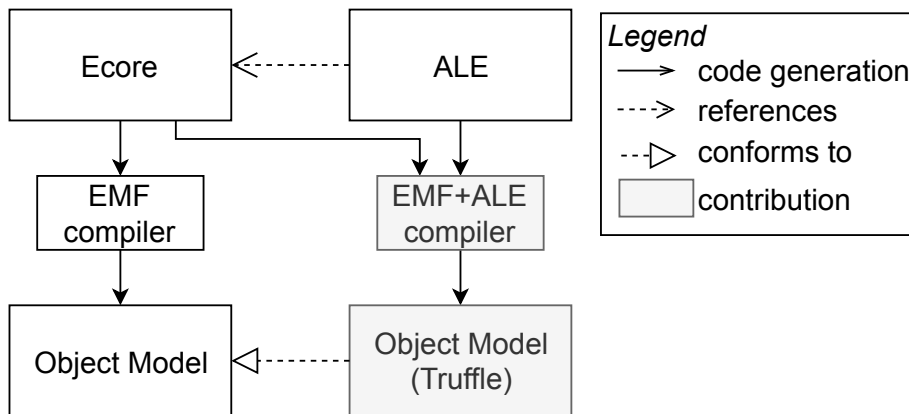

Figure 3: Presentation of EMF’s compiler and our compiler.

developed by extending the existing JET template, but our experience showed the limitation of such a template system during the integration of the compilation of ALE. Indeed, the compilation of the body of ALE methods and the introduction of more variation points in the compilation process (e.g., exploration of different Truffle implementation patterns during our experiments), lead to really large and challenging to maintain templates.

Consequently, we chose to develop our compiler using Xtend and Javapoet. Xtend is one of the technologies at the core of the Xtext framework [EB10] and proved itself a relevant solution for the implementation of language interpreters and compilers. Javapoet⁶ is a Java library dedicated to the generation of Java source code and comes in the form of a fluent API.

At the bottom of ??, we present the conformance relation between the Java object model generated by EMF’s compiler and the Java object models with Truffle concepts generated by our compiler. This conformance relation is twofold. First, the two object models are statically indistinguishable, present the same Java signature, making them fully substitutable. Second, the introduced Truffle concepts are built to preserve the semantics. Consequently, the execution of two versions of the same specification compiled with and without our approach produces the same results. Meaning that our compiler is a safe replacement to EMF’s compiler, allowing a fully automated gain of performance on top of interpreters running on GraalVM.

Our compiler is about 4000 lines of code. The Truffle specific parts are composed of 7 lines of code in the method body compiler, 180 lines of code in the classes structure compiler, mainly related to the PICs and the introduction of `@TruffleBoundary` annotations, and 2 lines of code in the EMF factory compiler, also for the introduction of `@TruffleBoundary` annotations. The integration of our approach in an EMF compiler required 189 lines of code in total. Porting

⁶Javapoet: <https://github.com/square/javapoet>

back our approach to the official EMF implementation is straightforward and is the matter of translating the 180 lines into the JET template formalism.

6 Evaluation

In this section, we present the evaluation of our approach. In ??, we present the languages and programs used for the evaluation. Then, in ??, we present the experimental setup. Finally, ?? presents and analyzes the experimentation results.

6.1 Benchmarked Languages and Programs

To evaluate our results, we implemented four languages: MiniJava [Rob01], a teaching-oriented subset of Java, a functional language inspired by OCaml named Boa⁷, a Finite State Machine language⁸, and the educational procedural Logo language.

MiniJava is used to implement: the Fibonacci algorithm (`m_fibonacci`), a bubble sort algorithm [CLRS01] (`m_sort`), a binary tree manipulation algorithm⁹ (`binarytree`), and an implementation of the fannkuch algorithm¹⁰ [AR94] (`fannkuchredux`). Boa is used to implement a Fibonacci algorithm (`b_fibonacci`) and an insert sort algorithm [Knu97] (`b_sort`). The Finite State Machine language is used to define a set of four communicating state machines, sending messages to each other, presented in more detail in the companion webpage¹¹ (`buffers`). Finally, the Logo language is used to define a program that draws a Koch snowflake fractal¹² (`fractal`).

This selection represents a panel of languages. The choice has been made for being a maximum representative of targeted languages and conforming programs or models. This includes one functional language, one object-oriented language, a language dedicated to domain experts, and an “end-user” language. For the languages with paradigms allowing various sort of implementation, we propose programs covering different styles from arithmetic intensive programs to structure intensive programs, and from recursive style to iterative style.

6.2 Time measurement

The methodology presented below aims at producing repeatable performance measurement of language interpreter performances [GBE07]. We qualify the

⁷Programming languages Zoo: <http://plzoo.andrej.com/language/boa.html>

⁸Finite State Machine language: <https://github.com/gemoc/MODELS2017Tutorial/>

⁹Binarytree algorithm: <https://benchmarksgame-team.pages.debian.net/benchmarksgame/description/binarytrees.html#binarytrees>

¹⁰Fannkuch algorithm: <https://benchmarksgame-team.pages.debian.net/benchmarksgame/description/fannkuchredux.html#fannkuchredux>

¹¹Companion webpage: <https://manuelleduc.github.io/ecmfa-2020/#system-of-finite-state-machines-example>

¹²Koch snowflake: https://en.wikipedia.org/wiki/Koch_snowflake

performance by using the steady-state performance. In other words, the performance of the programs once it has reached a stable execution state. Each program is executed fifty times in a row in a JVM. We repeat each measurement three times.

All the benchmarks presented below are executed on Debian 9, with 15Go of RAM and an Intel(R) Xeon(R) W-2104 CPU (Quad Core - 3.20GHz). We use HotSpotVM version 1.8.0_222, GraalVM version 19.1.1 and Truffle version 19.1.1.

In addition, we use JMH v1.21¹³ to run our experiments. JMH is a Java framework that mitigates the nondeterministic behaviors inherent to the JVM internals. Additionally, we execute our benchmarks using Krun [BBK⁺17]. Krun is a framework that assists in the definition of repeatable benchmarks. For instance, Krun restarts the benchmarking computer between each new measurement, to avoid the influence of pre-cached data on the program's execution. Krun also checks and sets various hardware settings known to influence the repeatability of measurements. For instance, Krun fixes the CPU frequency and checks the CPU temperature at the beginning of each measurement. With this setup, we mitigate the nondeterministic behavior at the hardware, system, and virtual machine levels, improving the repeatability of our benchmarks [KBT05].

We benchmark each combination of a virtual machine, an implementation pattern, and a program by running three times 50 executions, obtaining 150 measurements for each combination.

By manual inspection of the measured time, we observe that the ten first executions are enough to warm up the virtual machine and to reach a steady-state. We calculate the performance of the programs using the mean of the 120 remaining executions, once the ten warmup iterations of each run have been excluded. Additionally, we evaluated the confidence interval of the measurements for a confidence level of 99%. All the confidence intervals are below 0.03 seconds, which allows a safe and unambiguous analysis of our results.

6.3 Results

?? summarizes the measured performance of the programs on our benchmark. The HotSpot VM + Switch, HotSpot VM + Interpreter, and GraalVM + Interpreter lines present the measurements of respectively: the Switch implementation on the HotSpot VM; the Interpreter implementation on the HotSpot VM; and the Interpreter implementation on the GraalVM. The ATG + Interpreter line presents the measurements of language compiled with our approach. Each *Mean* line presents the calculated mean time of the measurements in seconds. Each SHS line presents the speedup of the current implementation compared to the HotSpot VM + Switch version. Each SHI line presents the speedup of the current implementation compared to the HotSpot VM + Interpreter version. Finally, the SGI line presents the speedup of the current implementation compared to the GraalVM + Interpreter version.

¹³Java Microbenchmark Harness (JMH): <https://openjdk.java.net/projects/code-tools/jmh/>

Table 2: Benchmarks measurement summary. Mean = mean execution time in second; SHS=Speedup relative to the HotSpot VM + Switch; SHI = Speedup relative to the HotSpot VM + Interpreter; SGI = Speedup relative to the GraalVM + Interpreter; ATG = Automatic Truffle Generation

parameters:	Minijava				Boa		FSM	Logo	Geo. Mean
	m_fibonacci (30)	m_sort (1000)	binarytree (11)	fannkuchredux (8)	b_fibonacci (30)	b_sort (500)	buffers (5 · 10 ⁷)	fractal (17)	
<i>HotSpot VM + Switch</i>									
Mean (s)	11.80	16.39	7.06	6.67	2.04	1.94	7.84	12.44	
<i>HotSpot VM + Interpreter</i>									
Mean (s)	9.18	14.91	5.86	5.28	1.79	1.71	4.64	11.14	
SHS	x1.28	x1.10	x1.20	x1.26	x1.14	x1.13	x1.69	x1.12	x1.23
<i>GraalVM + Interpreter</i>									
Mean (s)	5.29	9.89	3.32	3.17	1.49	1.57	4.04	7.87	
SHI	x1.74	x1.51	x1.77	x1.66	x1.22	x1.09	x1.15	x1.42	x1.42
SHS	x2.23	x1.66	x2.13	x2.10	x1.40	x1.23	x1.94	x1.58	x1.75
<i>ATG + Interpreter</i>									
Mean (s)	4.21	9.23	2.98	2.72	1.25	1.43	3.54	7.24	
SGI	x1.26	x1.07	x1.11	x1.17	x1.17	x1.10	x1.14	x1.09	x1.14
SHI	x2.18	x1.61	x1.97	x1.94	x1.43	x1.19	x1.31	x1.547	x1.61
SHS	x2.81	x1.78	x2.37	x2.45	x1.63	x1.35	x2.21	x1.72	x1.99

The speedups discussed below are produced using the geometric mean of the speedups obtained for each program on a given configuration and are presented in the rightmost column. We use the term *general* speedup when talking about the speedup calculated using the geometric mean.

First, as presented in ??, the straightforward transition from HotSpot VM + Switch to GraalVM + Interpreter already allows a general speedup of x1.75, ranging from x1.23 to x2.23.

Our approach, built on top of the GraalVM + Interpreter version, yields an additional general speedup of x1.14, ranging from x1.07 to x1.26. This adds up to a general speedup of x1.99, ranging from x1.35 to x2.81, when compared to the HotSpot VM + Switch version. While the effect of our contribution leads to smaller speedups than the straightforward switch from HotSpot VM + Switch to GraalVM + Interpreter, is it important to consider the opportunity offered by our approach to provide additional performance gains to language engineers at zero cost. Indeed, the only manual operation to perform is the recompilation of languages using a new compiler.

Complementarily, we also evaluate the manually introduced PIC presented in ?. Introducing the PIC yield a general speedup of x1.08, ranging from x0.92 to x1.19 relatively to the ATG + Interpreter version, making it detrimental in some cases and forces language engineers to manipulate performance-specific concepts during language specification.

In conclusion, our results show the benefit of our approach in all cases, especially when improving the performance of language interpreters to their maximum is required while preserving the compatibility with existing EMF tool support.

7 Related Work

Many language workbenches aim at providing tools and methods for defining the various concerns of languages. However, performances in language runtimes

have mostly been tackled in an ad-hoc way, through handcrafted optimizations motivated by the number of language users and the targeted application domains. For instance, in the realm of general-purpose languages, the Java virtual machines have evolved through different generations of optimization until the current JIT compiler, mostly handcrafted [CFM⁺97]. More recently, the V8 JavaScript engine¹⁴ has been finely tuned by language experts to boost its performance and to make any application executed within the browser extremely efficient [MDM16].

Little attention has been given to the performance of language interpreters for DSLs engineered by language designers through systematic approaches offered by language workbenches. Internal DSLs can exploit the underlying host language runtime, by optimizing in the desugaring phase (e.g., LMS [RO12] or SugarJ [ERKO11]), for acceptable performance. In the context of external DSLs, which cannot rely on the infrastructure of a host language, compilers can be tailored using optimizing compiler techniques [NCM03, EH07, JTH01]. These techniques, however, require advanced language implementation skills, which hamper their use in language workbenches, where language designers are encouraged to manipulate language specifications instead.

Interpreted external DSLs are usually the ones suffering the most from poor performances. The common approach consists in defining an interpreter over the abstract syntax. Using an object-oriented metalanguage, the design pattern Interpreter [GHJV95] offers an elegant and widely adopted architecture to structure its definition through the traversal of the abstract syntax tree and context passing over the traversal. Advanced object-oriented paradigms such as open-classes can be employed to keep the separation of concerns at design time, and inline the interpreter within the structure of the abstract syntax at compile time in order to minimize the runtime overhead. The Switch mechanism offered by the Eclipse Modeling Framework for traversing Ecore-based metamodels [SBMP08] demonstrates the benefits with regards to the common object-oriented design pattern or specific framework.

Vergu et al. [VTV19] propose their work on the performance of the meta-*interpreter* of DynSem, a metalanguage integrated into the Spoofox language workbench. Where we address the challenge of interpreter performance by reifying Truffle optimizations in a language specification compiler, they tackle it by optimizing a language specifications meta-*interpreter* with Truffle. While difficult to compare due to the different nature of the metalanguages used for the language specifications, their results show the interest of applying Truffle in meta-*interpreters*.

A different approach following a similar objective of improving performance consists of applying approximate computing techniques. Several related works explore such an approach in the context of specific application domains such as signal processing [HS99]. While this approach provides good results in such applications domains, it is bound to possible areas of approximation. Instead, our approach keeps the nominal execution flow described by the execution semantics,

¹⁴V8 Javascript engine: <https://v8.dev/>

and as such, can be applied to any DSL interpreter.

8 Conclusion and Future Work

In this paper, we propose an optimized alternative to the standard execution framework for metamodel-based interpreted DSLs, while preserving the compatibility with existing tool support. Following our approach, interpreters are optimized by introducing Truffle specification concepts on the object model implementation and introducing truffle boundaries, allowing Truffle to optimize the interpreter at runtime while preventing undesirable code explosions efficiently. We automatically incorporate Truffle in the language interpreter implementation by leveraging on the language-specific information provided by the metalanguages. This makes some performance optimizations allowed by Truffle accessible to language engineers at zero cost.

We evaluate our approach on four heterogeneous languages and eight programs, covering a broad spectrum of language paradigms. We show a performance speedup of x1.14 on average, ranging from x1.07 to x1.26 while being non-intrusive of the usual development process, and while preserving the compatibility of the language interpreter implementations with their tool support.

Future work Our first exploratory results with the PIC highlight the interest of the introduction of additional optimizations. It is interesting to explore further the criteria that influence the relevance of Truffle optimization and to pursue the identification of systematically applicable criteria for their application. Besides, in this work, we leverage on the general-purpose optimizations provided by Truffle. A promising step towards more efficient language interpreters is the automatic generation of specialized Graal-based JIT optimizations, derived from the language specifications.

References

- [ACL⁺98] Ali-Reza Adl-Tabatabai, Michal Cierniak, Guei-Yuan Lueh, Vishesh M. Parikh, and James M. Stichnoth. Fast, effective code generation in a just-in-time java compiler. pages 280–290, 1998. URL: <https://doi.org/10.1145/277650.277740>, doi:10.1145/277650.277740.
- [AR94] Kenneth R. Anderson and Duane Rettig. Performing lisp analysis of the fannkuch benchmark. *SIGPLAN Lisp Pointers*, VII(4):2–12, October 1994. doi:10.1145/382109.382124.
- [BBK⁺17] Edd Barrett, Carl Friedrich Bolz-Tereick, Rebecca Killick, Sarah Mount, and Laurence Tratt. Virtual machine warmup blows hot and cold. *PACMPL*, 1(OOPSLA):52:1–52:27, 2017. URL: <https://doi.org/10.1145/3133876>, doi:10.1145/3133876.

- [BDV⁺16] Erwan Bousse, Thomas Degueule, Didier Vojtisek, Tanja Mayerhofer, Julien DeAntoni, and Benoît Combemale. Execution framework of the GEMOC studio (tool demo). In *SLE 2016*, pages 84–89, 2016. URL: <http://dl.acm.org/citation.cfm?id=2997384>.
- [BvdBH⁺15] Bas Basten, Jeroen van den Bos, Mark Hills, Paul Klint, Arnold Lankamp, Bert Lisser, Atze van der Ploeg, Tijs van der Storm, and Jurgen J. Vinju. Modular language implementation in rascal - experience report. *Sci. Comput. Program.*, 114:7–19, 2015. doi:10.1016/j.scico.2015.11.003.
- [CFM⁺97] Timothy Cramer, Richard Friedman, Terrence Miller, David Seberger, Robert Wilson, and Mario Wolczko. Compiling java just in time. *IEEE Micro*, 17(3):36–43, 1997. doi:10.1109/40.591653.
- [CLCM00] Curtis Clifton, Gary T. Leavens, Craig Chambers, and Todd D. Millstein. Multijava: modular open classes and symmetric multiple dispatch for java. In *OOPSLA 2000*, pages 130–145, 2000. doi:10.1145/353171.353181.
- [CLRS01] Thomas H Cormen, Charles E Leiserson, Ronald L Rivest, and Clifford Stein. Introduction to algorithms second edition, 2001.
- [DS84] L. Peter Deutsch and Allan M. Schiffman. Efficient implementation of the smalltalk-80 system. In *POPL*, pages 297–302. ACM Press, 1984.
- [EB10] Moritz Eysholdt and Heiko Behrens. Xtext: implement your language faster than the quick and dirty way. In *Companion to the 25th Annual ACM SIGPLAN Conference on Object-Oriented Programming, Systems, Languages, and Applications, SPLASH/OOPSLA 2010, October 17-21, 2010, Reno/Tahoe, Nevada, USA*, pages 307–309, 2010. doi:10.1145/1869542.1869625.
- [EEK⁺12] Sven Efftinge, Moritz Eysholdt, Jan Köhnlein, Sebastian Zarnekow, Robert von Massow, Wilhelm Hasselbring, and Michael Hanus. Xbase: implementing domain-specific languages for java. In *GPCE 2012*, pages 112–121, 2012. doi:10.1145/2371401.2371419.
- [EG01] M. Anton Ertl and David Gregg. The behavior of efficient virtual machine interpreters on modern architectures. In Rizos Sakellariou, John Gurd, Len Freeman, and John Keane, editors, *Euro-Par 2001 Parallel Processing*, pages 403–413, Berlin, Heidelberg, 2001. Springer Berlin Heidelberg.
- [EH07] Torbjörn Ekman and Görel Hedin. The jastadd system - modular extensible compiler construction. *Sci. Comput. Program.*, 69(1-3):14–26, 2007. doi:10.1016/j.scico.2007.02.003.

- [ERKO11] Sebastian Erdweg, Tillmann Rendel, Christian Kästner, and Klaus Ostermann. Sugarj: library-based syntactic language extensibility. In *OOPSLA 2011*, pages 391–406, 2011. doi:10.1145/2048066.2048099.
- [EVDSV⁺15] Sebastian Erdweg, Tijs Van Der Storm, Markus Völter, Laurence Tratt, Remi Bosman, William R Cook, Albert Gerritsen, Angelo Hulshout, Steven Kelly, Alex Loh, et al. Evaluating and comparing language workbenches: Existing results and benchmarks for the future. *Computer Languages, Systems & Structures*, 44:24–47, 2015.
- [Fut99] Yoshihiko Futamura. Partial evaluation of computation process, revisited. *Higher-Order and Symbolic Computation*, 12(4):377–380, 1999.
- [GBE07] Andy Georges, Dries Buytaert, and Lieven Eeckhout. Statistically rigorous java performance evaluation. In *OOPSLA 2007*, pages 57–76, 2007. doi:10.1145/1297027.1297033.
- [GHJV95] Erich Gamma, Richard Helm, Ralph Johnson, and John M. Vlissides. *Design Patterns: Elements of Reusable Object-Oriented Software*. Addison-Wesley Professional, 1 edition, 1995.
- [HCU91] Urs Hölzle, Craig Chambers, and David M. Ungar. Optimizing dynamically-typed object-oriented languages with polymorphic inline caches. In *ECOOP 1991*, pages 21–38, 1991. doi:10.1007/BFb0057013.
- [HS99] Rajamohana Hegde and Naresh R. Shanbhag. Energy-efficient signal processing via algorithmic noise-tolerance. In *Proceedings of the 1999 International Symposium on Low Power Electronics and Design, 1999, San Diego, California, USA, August 16-17, 1999*, pages 30–35, 1999. doi:10.1145/313817.313834.
- [JCB⁺15] Jean-Marc Jézéquel, Benoît Combemale, Olivier Barais, Martin Monperrus, and François Fouquet. Mashup of metalanguages and its implementation in the kermeta language workbench. *Software and System Modeling*, 14(2):905–920, 2015. URL: <https://doi.org/10.1007/s10270-013-0354-4>, doi:10.1007/s10270-013-0354-4.
- [JTH01] Simon Peyton Jones, Andrew Tolmach, and Tony Hoare. Playing by the rules: rewriting as a practical optimisation technique in ghc. In *Haskell workshop*, volume 1, pages 203–233, 2001.
- [KBT05] Tomas Kalibera, Lubomir Bulej, and Petr Tuma. Benchmark precision and random initial state. In *Proceedings of the 2005 International Symposium on Performance Evaluation of Computer*

- and *Telecommunication Systems (SPECTS 2005)*, pages 484–490, 2005.
- [Knu97] Donald Ervin Knuth. *The art of computer programming: sorting and searching*, volume 3. Pearson Education, 1997.
- [KV10] Lennart C. L. Kats and Eelco Visser. The spoofax language workbench: rules for declarative specification of languages and ides. In *OOPSLA 2010*, pages 444–463, 2010. doi:10.1145/1869459.1869497.
- [Lom67] Lionello Lombardi. Incremental computation: The preliminary design of a programming system which allows for incremental data assimilation in open-ended man-computer information systems. *Advances in Computers*, 8:247–333, 1967.
- [MDM16] Stefan Marr, Benoit Dalozé, and Hanspeter Mössenböck. Cross-language compiler benchmarking: are we fast yet? In *DLS 2016*, pages 120–131, 2016. doi:10.1145/2989225.2989232.
- [Mey92] Bertrand Meyer. *Eiffel the language Prentice Hall object-oriented series*. Prentice hall Upper Saddle River, NJ, USA, 1992.
- [NCM03] Nathaniel Nystrom, Michael R. Clarkson, and Andrew C. Myers. Polyglot: An extensible compiler framework for java. In *Compiler Construction, CC 2003*, pages 138–152, 2003. doi:10.1007/3-540-36579-6_11.
- [OC12] Bruno C. d. S. Oliveira and William R. Cook. Extensibility for the masses - practical extensibility with object algebras. In *ECOOP 2012*, pages 2–27, 2012. URL: https://doi.org/10.1007/978-3-642-31057-7_2, doi:10.1007/978-3-642-31057-7_2.
- [OMG06] OMG. Meta Object Facility (MOF) 2.0 Core Specification. <http://www.omg.org/spec/MOF/2.0/>, 2006.
- [Ora19] OracleLabs. Graalvm, 2019. URL: <https://www.graalvm.org>.
- [RO12] Tiark Rompf and Martin Odersky. Lightweight modular staging: a pragmatic approach to runtime code generation and compiled dsls. *Commun. ACM*, 55(6):121–130, 2012. doi:10.1145/2184319.2184345.
- [Rob01] Eric Roberts. An overview of minijava. In *SIGCSE 2001*, pages 1–5, 2001. doi:10.1145/364447.364525.
- [SBMP08] Dave Steinberg, Frank Budinsky, Ed Merks, and Marcelo Paterostro. *EMF: Eclipse Modeling Framework*. Pearson Education, 2008.

- [SWHJ16] Lukas Stadler, Adam Welc, Christian Humer, and Mick Jordan. Optimizing R language execution via aggressive speculation. In *DLS 2016*, pages 84–95, 2016. doi:10.1145/2989225.2989236.
- [TR03] Juha-Pekka Tolvanen and Matti Rossi. Metaedit+: defining and using domain-specific modeling languages and code generators. In *OOPSLA 2003*, pages 92–93, 2003. doi:10.1145/949344.949365.
- [UML05] Dec 2005. URL: <https://www.omg.org/spec/UML/2.5.1>.
- [VC15] Edoardo Vacchi and Walter Cazzola. Neverlang: A framework for feature-oriented language development. *Computer Languages, Systems & Structures*, 43:1–40, 2015. doi:10.1016/j.cl.2015.02.001.
- [Voe11] Markus Voelter. Language and IDE modularization and composition with MPS. In *GTTSE 2011*, pages 383–430, 2011. doi:10.1007/978-3-642-35992-7_11.
- [VRCG⁺99] Raja Vallée-Rai, Phong Co, Etienne Gagnon, Laurie Hendren, Patrick Lam, and Vijay Sundaresan. Soot - a java bytecode optimization framework. In *Proceedings of the 1999 Conference of the Centre for Advanced Studies on Collaborative Research, CASCON '99*, pages 13–. IBM Press, 1999. URL: <http://dl.acm.org/citation.cfm?id=781995.782008>.
- [VTV19] Vlad A. Vergu, Andrew Tolmach, and Eelco Visser. Scopes and frames improve meta-interpreter specialization. In *ECOOP 2019*, pages 4:1–4:30, 2019. doi:10.4230/LIPIcs.ECOOP.2019.4.
- [WW12] Christian Wimmer and Thomas Würthinger. Truffle: a self-optimizing runtime system. In *Conference on Systems, Programming, and Applications: Software for Humanity, SPLASH '12, Tucson, AZ, USA, October 21-25, 2012*, pages 13–14, 2012. doi:10.1145/2384716.2384723.
- [WWH⁺17] Thomas Würthinger, Christian Wimmer, Christian Humer, Andreas Wöß, Lukas Stadler, Chris Seaton, Gilles Duboscq, Doug Simon, and Matthias Grimmer. Practical partial evaluation for high-performance dynamic language runtimes. In *PLDI 2017*, pages 662–676, 2017. doi:10.1145/3062341.3062381.
- [WWS⁺12] Thomas Würthinger, Andreas Wöß, Lukas Stadler, Gilles Duboscq, Doug Simon, and Christian Wimmer. Self-optimizing ast interpreters. In *Proceedings of the 8th Symposium on Dynamic Languages, DLS '12*, pages 73–82, New York, NY, USA, 2012. ACM. URL: <http://doi.acm.org/10.1145/2384577.2384587>, doi:10.1145/2384577.2384587.

[WWW+13] Thomas Würthinger, Christian Wimmer, Andreas Wöß, Lukas Stadler, Gilles Duboscq, Christian Humer, Gregor Richards, Doug Simon, and Mario Wolczko. One VM to rule them all. In *ACM Symposium on New Ideas in Programming and Reflections on Software, Onward! 2013, part of SPLASH '13, Indianapolis, IN, USA, October 26-31, 2013*, pages 187–204, 2013. doi:10.1145/2509578.2509581.

This work is partially supported by the CWI/Inria associate team ALE (<http://gemoc.org/ale/>), the EU's Horizon 2020 Project No. 732223 CROSSMINER, and by the Direction Générale de l'Armement (Pôle de Recherche CYBER).