



**HAL**  
open science

## Evaluating the hardware cost of the posit number system

Yohann Uguen, Luc Forget, Florent de Dinechin

► **To cite this version:**

Yohann Uguen, Luc Forget, Florent de Dinechin. Evaluating the hardware cost of the posit number system. 29th International Conference on Field-Programmable Logic and Applications (FPL), Sep 2019, Barcelona, Spain. hal-02130912v2

**HAL Id: hal-02130912**

**<https://inria.hal.science/hal-02130912v2>**

Submitted on 27 Jun 2019 (v2), last revised 24 Jul 2019 (v4)

**HAL** is a multi-disciplinary open access archive for the deposit and dissemination of scientific research documents, whether they are published or not. The documents may come from teaching and research institutions in France or abroad, or from public or private research centers.

L'archive ouverte pluridisciplinaire **HAL**, est destinée au dépôt et à la diffusion de documents scientifiques de niveau recherche, publiés ou non, émanant des établissements d'enseignement et de recherche français ou étrangers, des laboratoires publics ou privés.

# Evaluating the hardware cost of the posit number system

Yohann Uguen

Univ Lyon, INSA Lyon, Inria, CITI  
F-69621 Villeurbanne, France  
yohann.uguen@insa-lyon.fr

Luc Forget

Univ Lyon, INSA Lyon, Inria, CITI  
F-69621 Villeurbanne, France  
luc.forget@insa-lyon.fr

Florent de Dinechin

Univ Lyon, INSA Lyon, Inria, CITI  
F-69621 Villeurbanne, France  
florent.de-dinechin@insa-lyon.fr

**Abstract**—The posit number system is proposed as a replacement of IEEE floating-point numbers. It is a floating-point system that trades exponent bits for significand bits, depending on the magnitude of the numbers. Thus, it provides more precision for numbers around 1, at the expense of lower precision for very large or very small numbers. Several works have demonstrated that this trade-off can improve the accuracy of applications. However, the variable-length exponent and significand encoding impacts the hardware cost of posit arithmetic. The objective of the present work is to enable application-level evaluations of the posit system that include performance and resource consumption.

To this purpose, this article introduces an open-source hardware implementation of the posit number system, in the form of a C++ templated library compatible with Vivado HLS. This library currently implements addition, subtraction and multiplication for custom-size posits. In addition, the posit standard also mandates the presence of the “quire”, a large accumulator able to perform exact sums of products. The proposed library includes the first open-source parameterized hardware quire.

This library is shown to improve the state-of-the-art of posit implementations in terms of latency and resource consumption. Still, standard 32 bits posit adders and multipliers are found to be much larger and slower than the corresponding floating-point operators. The cost of the posit 32 quire is shown to be comparable to that of a Kulisch accumulator for 32 bits floating-point.

## I. INTRODUCTION

Most machine implementations of real numbers rely on floating-point arithmetic. The ease-of-use of floating-point, which explains its popularity, hides complex hardware whose behaviour is specified by the IEEE-754 standard [11].

The posit number system (described in details in [10]) is an emerging machine representation of real numbers that aims at replacing IEEE-754 floating-point. The first posit claim is that floating-point is an inefficient representation. When the exponent can be encoded on only a few bits, the rest of the bits should be used to extend the precision. The second claim, adopted from Kulisch [14], is that the sum of many products is a pervasive operation, justifying specific hardware to compute it exactly. To this purpose, the draft posit standard [9] mandates a *quire*, a variant of the exact Kulisch accumulator [14] for the posit number system.

Most current evaluations of posits in applications are performed through software simulation [13], [3], [5], [6]. The

C/C++ SoftPosit library <sup>1</sup> (among others <sup>2</sup>) implements the latest posit standard and allows for direct comparison with floating-point numbers in terms of accuracy.

However, the hardware cost of posits is not yet completely known. Hardware posit adders and multipliers have been written in HDL [4], [12] or using Intel OpenCL SDK compliant templated C++ operators [16]. Using posits as a storage format by decoding/encoding from/to a large enough IEEE floating-point format as also been studied in [5]. Posits have been evaluated on applications such as machine learning [13], [3] or matrix multiply [5]. Among these works, only [13] is open-source and partially supports the quire, but only for 8-bit posits. [16] and [4] are parametric designs but are not open-source and do not support the quire. In terms of comparisons with floating-point, [16] describe their posit implementation as sub-optimal. Indeed, the present work, although similar in spirit, refines the architectures in [16], attempting to use the same datapath optimization tricks that are used in the floating-point operators it compares to [15]. Conversely, [4] compares a posit implementation to a floating-point implementation that is 3x larger than the state-of-the-art.

The present work improves the implementation of posit hardware with respect to all the previous works, and enables a comparison with state-of-the-art floating-point. It is parametric, open-source, and it is the first implementation to include a standard-compliant, parametric quire. As the quire is the posit incarnation of the exact Kulisch accumulator for IEEE floating-point, an implementation of the latter is provided for good measure.

The proposed implementation is a templated C++ library compliant with Vivado HLS. It currently offers standalone posit adders, subtractors and multipliers, with overloading of the C++ operators +, − and \* for posit datatypes. Alternatively, the quire can add or subtract posits, or posit products, without rounding error. This open-source library<sup>3</sup> is built on a custom internal representation and extensible to other operators. The longer-term objective is really to make it possible for designers to easily switch an HLS design between floating-point and posit arithmetic, in order to compare their respective

<sup>1</sup>[gitlab.com/cerlane/SoftPosit](https://gitlab.com/cerlane/SoftPosit)

<sup>2</sup>[posithub.org/docs/PDS/PositEffortsSurvey.html](https://posithub.org/docs/PDS/PositEffortsSurvey.html) as of march 6, 2019

<sup>3</sup>[gitlab.inria.fr/lforget/marto](https://gitlab.inria.fr/lforget/marto)

$S$	Regime		$es$		$F$	
0	1	1	0	1	0	1

Fig. 1. Posit decomposition example ( $N = 8$ ,  $w_{es} = 2$ )

accuracy/cost/performance trade-offs.

Section II introduces in more details the posit number system, the algorithms for decoding and encoding them, and the datapath parameters entailed by these algorithms. Section III provides details on the architectural improvements implemented in the proposed library. Section IV shows synthesis results of standalone operators compared to state-of-the-art floating-point. It also evaluates the quire in accumulation loops against IEEE floating-point and custom floating-point Kulisch accumulators.

## II. POSITS

The posit number system [10] is a floating-point encoding scheme with tapered precision. A posit format is defined by its size in bits ( $N$ ) and its exponent field width ( $w_{es}$ ), which are the two parameters of the proposed templated implementation.

### A. Decoding the posit

The value of Figure 1 will be used as an illustrative example of how posits work.

The first bit  $S$  of the posit encodes its sign. Here the value is positive as  $S = 0$ . The exponent  $E$  of the number is split in two parts. The first part is computed out of the (variable-size) regime field, defined by a sequence of  $l$  identical bits ended by the opposite bit. The encoded range  $k$  is  $-l$  if the bits of this sequence are equal to  $S$ , otherwise  $l - 1$ . In this example, the sequence consists in two ones:  $l = 2$ , therefore  $k = 1$ . The  $w_{es}$  following bits are xored with  $S$  to obtain the lower exponents bits  $es$ : the exponent  $E$  is the concatenation of  $k$  and  $es$ . In our example,  $E = 101$  as  $es = 01$ .

The remaining bits encode the fractional part  $F$  of the significand. An implicit bit  $I$  is obtained by negating  $S$ , here  $I = 1$ . Finally, the value of the posit can be defined as:

$$2^E \times (I.F - 2 \times S). \quad (1)$$

The value represented by the example is

$$2^{101_2} \times (1.01_2 - 2 \times 0) = 2^5 \times 1.25 = 40.$$

Note that the regime can extend to the point where there is no room for  $F$  or  $es$ . In this case, the bits shifted out are assumed to be zeros.

Posit formats admit two special values, 0 and Not a Real (NaR). For encoding 0, all the posit fields are null, including the implicit bit. NaR is the equivalent of IEEE-754 NaN (Not a Number). Its encoding only has the sign bit set. There is no special encodings for infinity: posit arithmetic saturates instead.

### B. Posit bounds and sizes

Due to the run length encoding of the range, posits with low magnitude exponents have more significand bits. The maximum precision  $w_F$  is obtained for the minimum length of the regime (2), therefore

$$w_F = N - (3 + w_{es})$$

On the other hand, maximal exponent is obtained when the regime running length is  $N - 1$ . In this case, all the  $es$  and  $F$  bits are pushed out by the regime. Hence the maximum exponent value is  $E_{Max} = (N - 2)2^{w_{es}}$ . The number of bits needed to store the exponent in two's complement format is therefore

$$w_E = 1 + \lceil \log_2((N - 2)2^{w_{es}}) \rceil = 1 + w_{ES} + \lceil \log_2(N - 2) \rceil$$

The  $w_{es}$  parameter allows trading between the range of the format and its precision. The posit standard [9] defines four formats with an encoding size  $N$  of 8, 16, 32 and 64 respectively. These formats are used for evaluation in this paper, although the library is fully parameterized in  $N$  and  $w_{es}$ . The exponent field size  $w_{es}$  of these formats follows the relation  $w_{es} = \log_2(N) - 3$ .

A posit-compliant environment must also provide a *quire*. This latter allows for the exact accumulation of posit products. It is based on the floating-point Kulisch accumulator. For the standard formats, product magnitudes range from  $2^{-\frac{N^2-2N}{4}}$  to  $2^{\frac{N^2-2N}{4}}$ . Hence,  $\frac{N^2}{2} - N + 1$  bits are required to store any such product in fixed-point representation. The standard motivates that the quire should easily be transferred to and from memory. To do so, it should have a size which is a multiple of 8. The addition of  $N - 2$  carry bits and one sign bit fulfil that goal, hence the width of standard format quires is

$$w_q = \frac{N^2}{2}.$$

The different sizes and bounds for standard posit formats are reported in Table I.

TABLE I  
DIMENSIONS AND BOUNDS OF STANDARD POSITS ( $w_{es} = \log_2(N) - 3$ )

$N$	$w_{es}$	$w_E$	$w_F$	$E_{Max}$	$w_q$	$w_{pif}$
8	0	4	5	6	32	14
16	1	6	12	28	128	23
32	2	8	27	120	512	40
64	3	10	58	496	2048	73

The next section introduces a custom internal representation for posits based on previously shown sizes. This internal representation is used inside further detailed arithmetic operators.

## III. ARCHITECTURE

The variable-length fields of the posit formats are not well suited to efficient computation on bit-parallel hardware. As all previous implementations, we first convert posits to a more hardware-friendly representation. A contribution of this work is to formally define this intermediate format.

### A. Posit intermediate format

The *posit intermediate format* (PIF) is a custom floating-point format used to represent with fixed size fields a posit value. Its main difference with standard floating-point is that the significand is stored in two's complement just like posit significand. This simplifies decoding, but also slightly simplifies the addition of two posits.

The significand is composed of three fields  $S$ ,  $I$  and  $F$ , where  $S$  is a sign bit,  $I$  is the explicit leading bit of the posit significand, and  $F$  is its fraction field, on  $w_F$  bits in order to accommodate the most accurate posits of the format (less accurate ones are right-padded with zeroes). For the example of Figure 1,  $S = 0$ ,  $I = 1$  and  $F = 010$  ( $w_F = 3$  so the posit fraction is padded with one zero in this case).

The exponent is stored as the offset from posit minimum exponent, on  $w_E$  bits. This is similar to the biased exponents of IEEE floats, and motivated by the same reasons: it simplifies the critical path of the operators, at the cost of small additions in the decoding/encoding of posits, whose latency is hidden by the longer latency of significand processing.

Posit numbers with maximum magnitude exponents have their fraction bits completely pushed out ( $F = 0$ ). For them, Equation 1 becomes

$$\begin{cases} 2^E \times 1, & \text{for positive numbers} \\ -2 \times 2^E = -2^{E+1}, & \text{for negative numbers} \end{cases}$$

Hence, the minimal exponent expressed in *posit intermediate format* is for  $-2^{-E_{Max}}$ . In this case, in order to verify  $E+1 = -E_{Max}$ , the exponent value is  $E = -E_{Max} - 1$ . This leads to a bias value  $Bias = (N - 2)2^{w_{es}} + 1$ .

Finally, three extra bits are added to the format. The  $isNaR$  bit is used to signal NaR. It avoids the necessity of checking for NaR in arithmetic operators. The Round and Sticky bits capture the necessary and sufficient rounding information that must be kept after an operation on PIF values to correctly round the resulting PIF value back to posit.

To summarize, a *posit intermediate format* contains the following fields:

- A sign  $S$  on 1 bit
- An exponent  $E$  on  $w_E$  bits
- An implicit bit  $I$  on 1 bit
- A significand  $F$  on  $w_F$  bits
- A NaR flag  $isNaR$  on 1 bit
- A round bit  $round$  on 1 bit
- A sticky bit  $sticky$  on 1 bit

The total width of the posit intermediate format is therefore  $w_{pif} = w_F + w_E + 5$  bits. Posit intermediate format sizes for standard posit formats are reported in Table I.

### B. Posit to PIF decoder

The proposed posit decoder is described in Figure 2.

The exponent of the posit is the combination of  $es$  and  $k$ , which is computed from the run-length  $l$  of the leading bit. Indeed, if the leading bit is 0, then  $k = -l$  ( $= \bar{l} + 1$ ); if it is 1, then  $k = l - 1$ . By skipping a bit at the start of the sequence,

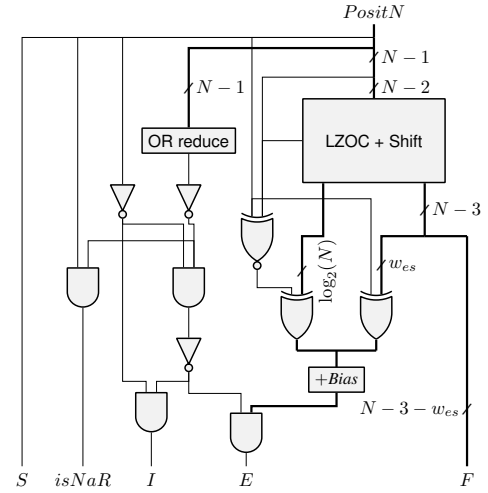

Fig. 2. Architecture of a posit decoder.

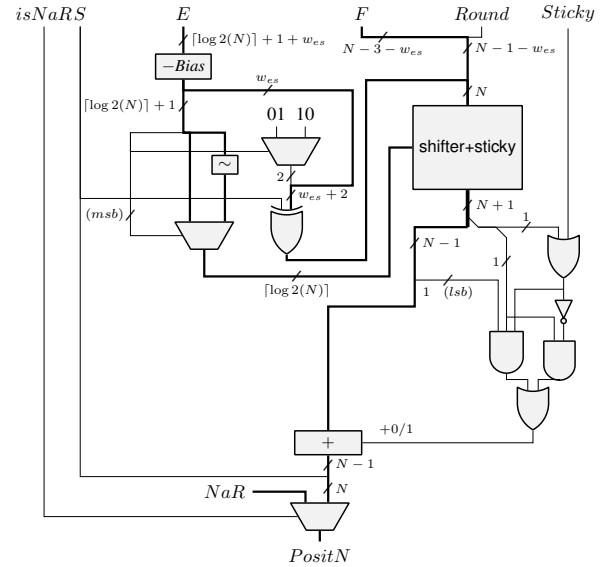

Fig. 3. Architecture of a posit encoder.

the count returns  $l' = l - 1$ . Therefore  $k = \overline{l' + 1} + 1$ , hence  $k = \bar{l}'$  if the leading bit is 0 or  $k = l'$  if the leading bit is 1. The same method can be applied for negative numbers by computing  $k = l'$  when the leading bit is 1 and  $k = \bar{l}'$  when the leading bit is 0. This method is different from the literature and allows for saving an addition when computing  $-l$ .

The expensive part of this architecture comes from (a) the OR reduce over  $N - 1$  bits to detect NaR numbers and (b) the leading zero or one count (LZOC + Shift) that consumes the regime bits while aligning the significand. The  $+Bias$  aligns the exponents to simplify following operators. This decoding cannot be compared to an IEEE floating-point equivalent as no decoding is needed.

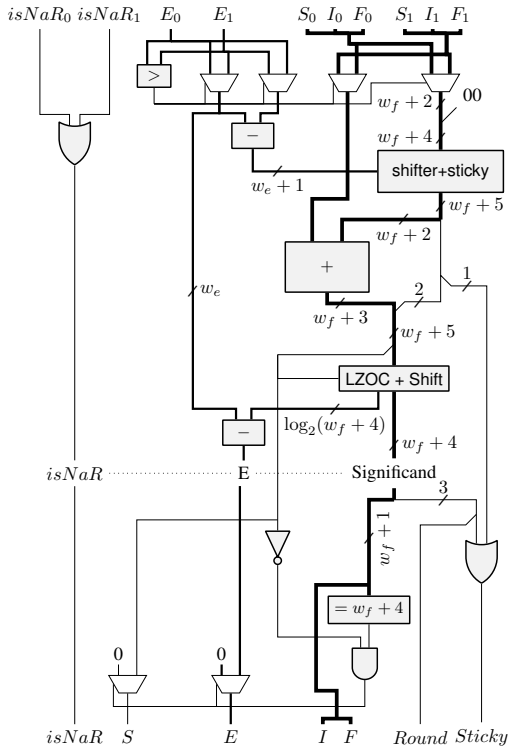

Fig. 4. Architecture of a PIF adder.

### C. PIF to posit encoder

Due to the variable-length encoding of posits, the position to which a PIF value must be rounded is known only when performing this conversion. The Round and Sticky bits carry synthetic information about the bits of the infinitely accurate result beyond the  $F$  bits, but the encoder (depicted in Figure 3) still embeds quite some logic.

The fraction is first shifted to include the regime bits and  $es$ . Once shifted, the first  $N - 1$  bits represent the unrounded posit without sign. The remaining bits of the shifted fraction are used to extract the actual round bit and compute the final sticky bit. This information is used to compute the rounding to the nearest with tie to even.

### D. PIF adder/subtractor and multiplier

The architectures of the PIF adder/subtractor (Figure 4) and multiplier (Figure 5) first compute the exact result (top part of the figures) using the transposition to the PIF format of classical floating-point algorithms.

Although the adder is a single-path architecture [15], its datapath can be minimized thanks to the classical observation that large shifts in the two shifters are mutually exclusive. Indeed, the normalizing LZOC+Shift of Figure 4 will only perform a large shift in a cancellation situation, but such a situation may only occur when the absolute exponent difference is smaller than 1, which means that the first shift was a very small one. Conversely, when the first shifter performs a large shift, the rightmost part of the significand can be immediately

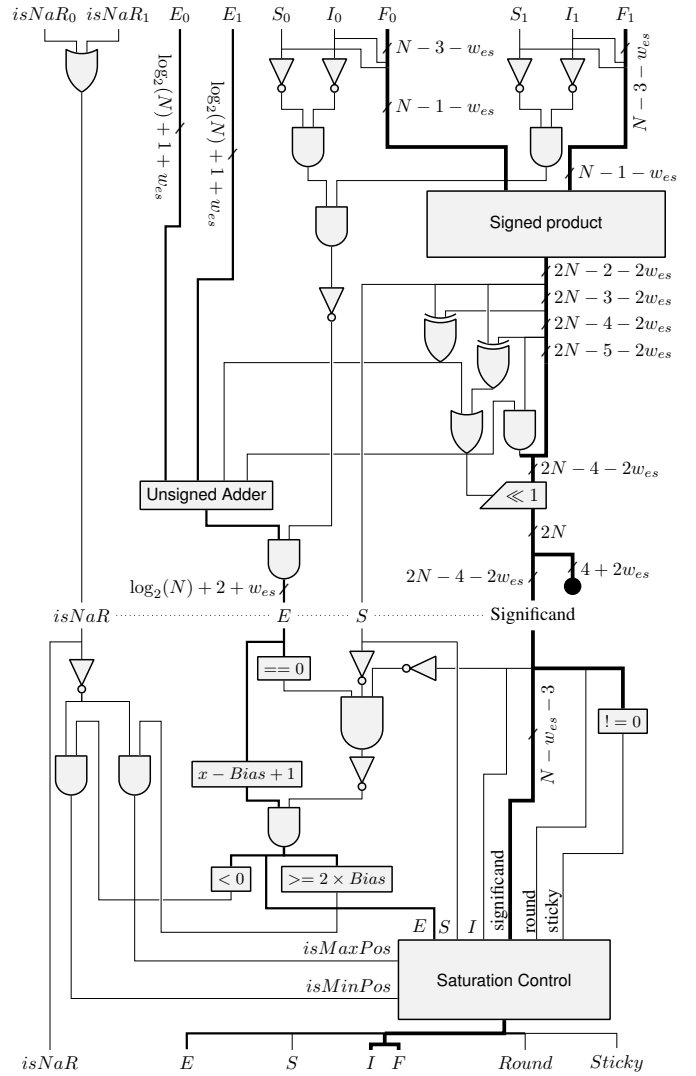

Fig. 5. Architecture of a PIF multiplier.

compressed into a sticky bit, since we know that it will not be shifted back by the second LZOC+Shift. All this allows us to keep most intermediate signals on  $w_f + 2$  to  $w_f + 6$  bits, where previous works [16], [4] seem to use datapaths that are twice as large.

The bottom part of Figures 4 and 5 normalize the exact result computed by the top parts to a PIF. For both operators, the exact significand must be realigned, correcting the exponent accordingly.

### E. Quire

The posit quire is able to perform exact sums and sums of products. Therefore, the input format of the quire is defined as the output of the exact multiplier from Figure 5 (top).

To add a simple posit to the quire, it is first converted to PIF, then the PIF value is converted to the same exact multiplier format, which is straightforward (the details are skipped for brevity).

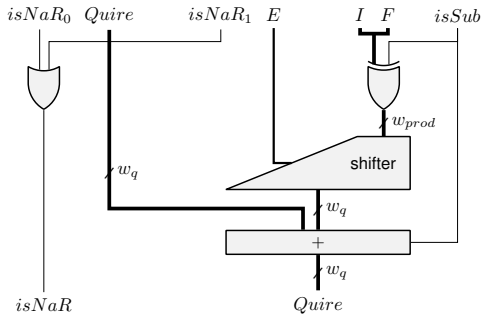

Fig. 6. Architecture of a posit quire addition/subtraction.

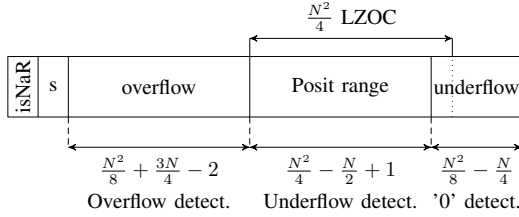

Fig. 7. Quire conversion to *posit intermediate format*.

The posit standard [9] specifies NaR as a special quire value. Testing this special value at each new quire operation is then expensive. Instead, this work proposes to add a flag bit that signals that the value held in the quire is NaR. This bit is set when NaR is added to the quire and stays set until the end of the computation. This extra bit can replace one of the quire carry bits. A slightly more expensive alternative would be to encode and decode NaR value when transferring quire to/from memory.

The proposed quire architecture is depicted in Figure 6.

1) *Addition of products to the quire*: The simplest implementation of the quire addition/subtraction is depicted in Figure 6 where the quire data structure is as depicted in Figure 7. An exact posit product fraction is shifted to the correct place to the quire format according to its exponent. A large adder then performs the addition with the previous quire value. The subtraction is performed at very little cost using the same method as in the posit adder/subtractor.

The long carry propagation delay of the addition in this architecture will restrict the maximum frequency achievable. To address this, a solution is to segment the quire [18]. The impact of this choice on cost and performance is evaluated in Section IV.

2) *Conversion from quire to posit*: The conversion of the quire value to a posit is divided in two steps. The quire is first converted to a PIF value (architecture depicted in Figure 8) before the latter is encoded to a posit (Section III-A).

#### IV. EVALUATION

All the designs presented here have been tested exhaustively for 8-bit and 16-bit standard posits against the reference Soft-

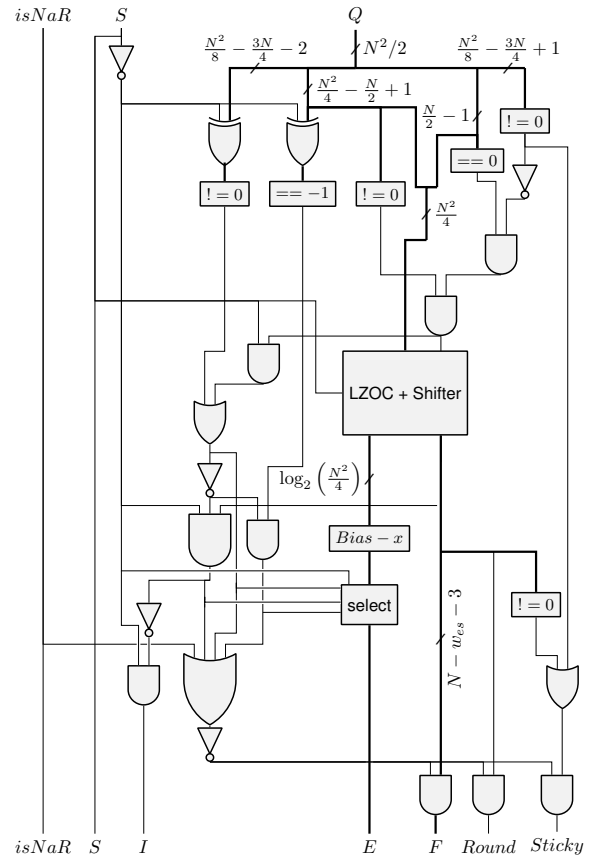

Fig. 8. Architecture of the conversion from the quire to a *posit intermediate format*.

Posit implementation. They have also been tested extensively for other sizes.

#### A. Comparison with the state-of-the-art

We first compare to the two parametric implementations of hardware posits reported so far. In [4], results are given for a Xilinx Zynq-7000. The adder operator is an adder only. Table II compares results from [4] to results obtained with our library in the same condition on the same target. All 32 bits examples metrics are improved by the proposed architectures. Regarding the 16 bits cases, the delays are greatly improved. However, there is one case (the 16 bits multiplier) where the resource consumption is higher. Even in this case, the area.time (AT) and  $AT^2$  of the proposed approach are better.

Table II also compares the proposed approach to [12]. The latter also compares to [4] but with an unclear experimental setup. Indeed, [12] compares its results given for a Virtex 7 FPGA with [4] approach for a Zynq-7000. To that end, the results of [12] are here given for a Zynq-7000 FPGA<sup>4</sup>. In all cases, the proposed approach either have similar delays but improve resource usage or reduce both delay and resource usage.

<sup>4</sup>source code from <https://github.com/manish-kj/Posit-HDL-Arithmetic> on June 26th, 2019

TABLE II  
COMPARISON WITH [4] AND [12] TARGETING ZYNQ (COMBINATORIAL COMPONENTS)

		N	LUTs	DSPs	delay (ns)
Adder	[4]	16	320	0	23
		32	981	0	40
	[12]	16	460	0	21
		32	1115	0	29
	This work	16	320	0	21
		32	745	0	24
Multiplier	[4]	16	218	1	24
		32	572	4	33
	[12]	16	271	1	19
		32	648	4	27
	This work	16	253	1	18
		32	479	4	28

TABLE III  
COMPARISON WITH [16] TARGETING STRATIX V

		N	ALMs	DSPs	cycles	FMax (MHz)
Add/Sub	[16]	16	~500	0	~49	~550
		32	~1000	0	~51	~520
	This work	16	327	0	19	584
		32	636	0	24	539
Multiplier	[16]	16	~330	1	~35	~600
		32	~600	1	~38	~550
	This work	16	199	1	16	600
		32	452	2	21	445

In [16], results are given for a Stratix V FPGA. Their adder operator is actually an adder/subtractor. The corresponding comparison is in Table III. For this table, we used VivadoHLS 2018.3 to generate VHDL files which were then synthesized using Quartus 18.1. This worked out-of-the-box for our designs, at the cost of sub-optimal QoR. We report approximate data for [16] since it is read from graphical plots.

In general, the operators developed in this work require fewer resources and have shorter critical paths. This is mainly due to rigorous implementation of each component (shifters, lzoc, etc.) and improvements over existing architectures (addition saved in the encoder, contraction of the adder addition similar to state-of-the-art floating-point adders, etc.). There is a discrepancy in the 32-bit multiplication in Table III: the 29x29 multiplier is implemented as two DSP blocks in 36x36 mode [1] in our case, while it is implemented in [16] as one DSP block in 27x27 mode, plus some logic. The slower frequency of our library in this case is not surprising, as we synthesize for an Intel FPGA the VHDL generated for a Xilinx FPGA. It will be solved in the near future by a portable HLS library instead of the current Vivado-specific one [7].

### B. Comparison with floating-point operators

All the remaining results given in this work are obtained using Vivado HLS and Vivado 2018.3 targeting 3ns delay for a Kintex 7 FPGA (xc7k160tfg484-1).

Table IV presents synthesis results for the posit adder/subtractor and multiplier. They are compared with

TABLE IV  
SYNTHESIS RESULTS OF POSIT AND IEEE FLOATING-POINT ADDERS AND MULTIPLIERS.

		N	LUTs	Regs.	DSPs	cycles	delay (ns)	
Adder	Float	32	341	467	0	9	2.529	
		64	641	1098	0	11	2.562	
		Soft FP [17]	16	205	228	0	10	2.453
			32	416	527	0	13	2.239
		IEEE Add	64	1237	1545	0	19	2.702
			16	216	205	0	12	2.331
	Posit	32	425	375	0	14	2.690	
		64	918	792	0	17	2.737	
		16	383	358	0	18	2.702	
		32	738	811	0	22	2.659	
		64	1660	2579	0	33	2.609	
		Multiplier	Float	32	80	193	3	7
64	196			636	11	17	2.568	
Soft FP [17]	16		38	127	1	8	1.825	
	32		67	228	2	9	2.193	
Posit	64		259	651	9	10	3.299	
	16		269	292	1	16	2.361	
32	544		710	4	21	2.421		
64	1501		2410	16	42	2.816		

floating-point operators obtained using the `float` and `double` types in a C program input to Vivado (hence the focus on 32 and 64-bit precisions). Vivado here is not IEEE-compliant as subnormals are treated as 0, but can be considered as the state-of-the-art floating-point for Xilinx FPGAs.

One could argue that it is unfair to compare a vendor-optimized float IP with an HLS implementation of posits. For this reason, we also provide results for a recent HLS-oriented templated floating-point library [17]. Unfortunately, it is not IEEE-compliant neither, lacking subnormal support. Therefore, we implemented an HLS version of the IEEE floating-point addition, reported as "IEEE Add".

In these experiments, the posit adder typically requires between 2x and 3x resources and is 2x slower than its floating-point counterpart. The posit multiplier is similarly more expensive and slower. Some of it is due to the variable-length field encoding and decoding (Figures 2 and 3). Some of it is due to the slightly extended internal precision of posits. There may also be some overhead due to the use of HLS for posits, especially in latency, but the comparison with the HLS FP of [17], as well as earlier work on the same subject [2] and "IEEE Add", suggest that HLS tools are quite good for basic floating-point.

### C. Quire evaluation

The synthesis results for the quire are given in Table V where we perform 1000 sums of product and return the result as a posit. They are compared to a floating-point Kulisch accumulator and to regular floating-point hardware. Kulisch and quire are presented in unsegmented (U) version along with two segmented versions (S32 and S64 for segments of 32 or 64 bits). The unsegmented versions are not able to achieve 3ns

TABLE V  
SYNTHESIS RESULTS FOR A SUM OF 1000 PRODUCTS (U: UNSEGMENTED,  
S32 AND S64: SEGMENTS SIZES OF 32 AND 64 BITS)

		LUTs	Regs.	DSPs	cycles	delay (ns)
Quire 16	U	1409	1763	1	1028	3.215
	S32	1239	1431	1	1031	2.643
	S64	1185	1555	1	1030	2.756
Quire 32 (512 bits)	U	5068	6256	4	1040	8.850
	S32	4394	4779	4	1055	2.854
	S64	3783	4564	4	1047	2.961
Kulisch 32 (559 bits)	S32	4446	5290	2	1050	2.875
	S64	4365	5276	2	1041	2.854
Float 32		460	806	3	10011	2.676
Float 64		892	1999	11	12021	2.737

TABLE VI  
DETAILED SYNTHESIS RESULTS OF HARDWARE POSIT QUIRE (U:  
UNSEGMENTED, S32 AND S64: SEGMENT SIZES OF 32 AND 64 BITS)

		LUTs	Regs.	DSPs	cycles	delay (ns)	
Posit 16	Decoding	59	64	0	4	1.986	
	Product	50	113	1	7	1.832	
	Quire addition	U	499	1078	0	5	2.681
		S32	459	357	0	4	2.628
		S64	432	543	0	5	2.437
	Carry prop.	S32	108	137	0	5	2.548
		S64	71	134	0	3	2.545
	Quire to posit	560	480	0	10	2.609	
	Posit 32	Decoding	137	142	0	5	2.158
		Product	93	277	4	10	2.143
Quire addition		U	2384	4712	0	7	5.050
		S32	1424	984	0	5	2.679
		S64	1148	1066	0	4	2.488
Carry prop.		S32	519	535	0	17	2.549
		S64	480	531	0	9	2.945
Quire to posit		2534	2439	0	17	2.878	

due to the long carry propagation. The Kulisch accumulator used in this paper is similar to the 2's complement Kulisch 3 variant architecture from [18], but with a final conversion to float that is IEEE-compliant (round to nearest, ties to even). The implementation has been validated against MFPR [8] simulations. Classically, using an exact accumulator consumes roughly 10x more resources but reduces the latency by 10x, while making the computation exact.

Here the cost and performance of a posit32 quire and a Kulisch accumulator for 32 bits floats are almost identical. This illustrates that the cost of posit decoding is comparable to that of handling subnormals in floating-point.

Detailed synthesis results of all the subcomponents are given in Table VI. The accumulation loop is the *Quire addition* component. It can be pipelined with an initiation interval of one cycle. During synthesis, the *Carry propagation* component will be merged with the *Quire addition*, reducing its cost. However, there is an irreducible latency for the final carry propagation once the accumulation is over.

The *Decoding* and *Product* components can be pushed out

of the accumulation loop and pipelined to feed the *Quire addition* component. Conversely, carries must be propagated before the conversion *Quire to posit* can occur. Therefore, the total latency of the design is approximately the sum of the combined *Decoding*, *Product* and *Quire addition* pipeline depths; the *Quire addition* initiation interval, times the number of products to add; the *Carry propagation* pipeline depth; and the *Quire to posit* pipeline depth.

This latency is amortized for large sums. However, it has to be taken into account when considering the quire to add a few values, e.g. to emulate an FMA or a fused dot product.

## V. CONCLUSION

The purpose of this work is to enable evaluating the cost of converting a floating-point application to posits. To that end, a Vivado HLS templated C++ library implements the posit number system, including the quire. This library has been implemented with the same care as state-of-the-art floating-point, with several improvements in the datapath that translate to greatly improved performance compared to previous posit implementations. Posit hardware is found to be more expensive than float hardware. However, for applications where posits are more accurate than floats of the same size, the real use case should be to vary the parameters, so as to find which arithmetic provides the required application-level accuracy at the minimal cost. We hope that this work enables such studies.

Future work includes completing the library with missing operations (division, square root), and making it portable to a broader range of HLS tools.

## Acknowledgements

This work was partly funded by the Imprenum project of Agence Nationale de la Recherche.

## REFERENCES

- [1] Altera Corporation. *Stratix-V Device Handbook*, 2013.
- [2] Samridhi Bansal, Hsuan Hsiao, Tomasz Czajkowski, and Jason H Anderson. High-level synthesis of software-customizable floating-point cores. In *Design, Automation & Test in Europe*, pages 37–42. IEEE, 2018.
- [3] Zachariah Carmichael, Hamed F. Langroudi, Char Khazanov, Jeffrey Lillie, John L. Gustafson, and Dhireesha Kudithipudi. Performance-efficiency trade-off of low-precision numerical formats in deep neural networks. In *Proceedings of the Conference for Next Generation Arithmetic*, pages 3:1–3:9. ACM, 2019.
- [4] Rohit Chaurasiya, John Gustafson, Rahul Shrestha, Jonathan Neudorfer, Sangeeth Nambiar, Kaustav Niyogi, Farhad Merchant, and Rainer Leupers. Parameterized Posit Arithmetic Hardware Generator. In *36th International Conference on Computer Design*, pages 334–341. IEEE, 2018.
- [5] Jianyu Chen, Zaid Al-Ars, and H.P. Hofstee. A matrix-multiply unit for posits in reconfigurable logic leveraging (open)CAPI (online). pages 1–5, 03 2018.
- [6] Florent De Dinechin, Luc Forget, Jean-Michel Muller, and Yohann Uguen. Posits: the good, the bad and the ugly. In *Proceedings of the Conference for Next Generation Arithmetic*, page 6. ACM, 2019.
- [7] Luc Forget, Yohann Uguen, Florent de Dinechin, and David Thomas. A type-safe arbitrary precision arithmetic portability layer for HLS tools. In *International Symposium on Highly Efficient Accelerators and Reconfigurable Technologies*, pages 1–6. Nagasaki, Japan, June 2019.
- [8] Laurent Fousse, Guillaume Hanrot, Vincent Lefèvre, Patrick Pélissier, and Paul Zimmermann. MPFR: A multiple-precision binary floating-point library with correct rounding. *ACM Transactions on Mathematical Software*, 33(2):13, 2007.



- [9] Posit Working Group. Posit standard documentation, June 2018. Release 3.2-draft.
- [10] John L Gustafson and Isaac T Yonemoto. Beating floating point at its own game: Posit arithmetic. *Supercomputing Frontiers and Innovations*, 4(2):71–86, 2017.
- [11] IEEE standard for floating-point arithmetic. IEEE 754-2008, also ISO/IEC/IEEE 60559:2011, August 2008.
- [12] Manish Kumar Jaiswal and Hayden K-H So. Pacogen: A hardware posit arithmetic core generator. *IEEE Access*, 7:74586–74601, 2019.
- [13] Jeff Johnson. Rethinking floating point for deep learning. *arXiv preprint arXiv:1811.01721*, 2018.
- [14] Ulrich Kulisch. *Computer arithmetic and validity: theory, implementation, and applications*. Walter de Gruyter, 2013.
- [15] Jean-Michel Muller, Nicolas Brunie, Florent de Dinechin, Claude-Pierre Jeannerod, Mioara Joldes, Vincent Lefèvre, Guillaume Melquiond, Nathalie Revol, and Serge Torres. *Handbook of Floating-Point Arithmetic, 2nd edition*. Birkhauser Boston, 2018.
- [16] Artur Podobas and Satoshi Matsuoka. Hardware implementation of POSITs and their application in FPGAs. In *International Parallel and Distributed Processing Symposium Workshops*, pages 138–145. IEEE, 2018.
- [17] David Thomas. Templatised soft floating-point for high-level synthesis. In *27th Annual International Symposium on Field-Programmable Custom Computing Machines*. IEEE, 2019.
- [18] Yohann Uguen and Florent De Dinechin. Design-space exploration for the Kulisch accumulator (Online). 2017.