



**HAL**  
open science

## High-Performance Computing at Exascale: challenges and benefits

Mathieu Lobet, Matthieu Haefele, Vineet Soni, Patrick Tamain, Julien Derouillat, Arnaud Beck

► **To cite this version:**

Mathieu Lobet, Matthieu Haefele, Vineet Soni, Patrick Tamain, Julien Derouillat, et al.. High-Performance Computing at Exascale: challenges and benefits. 15ème congrès de la Société Française de Physique division Plasma, Jun 2018, Bordeaux, France. hal-01820511

**HAL Id: hal-01820511**

**<https://inria.hal.science/hal-01820511>**

Submitted on 21 Jun 2018

**HAL** is a multi-disciplinary open access archive for the deposit and dissemination of scientific research documents, whether they are published or not. The documents may come from teaching and research institutions in France or abroad, or from public or private research centers.

L'archive ouverte pluridisciplinaire **HAL**, est destinée au dépôt et à la diffusion de documents scientifiques de niveau recherche, publiés ou non, émanant des établissements d'enseignement et de recherche français ou étrangers, des laboratoires publics ou privés.



# High-Performance Computing at Exascale: challenges and benefits

Mathieu Lobet, Matthieu Haefele, Vineet Soni, Patrick  
Tamain, Julien Derouillat, Arnaud Beck

Maison de la Simulation, CEA, CNRS, Université Paris-Sud, UVSQ,  
Universite Paris-Saclay, F-91191 Gif-sur-Yvette, France  
([mathieu.lobet@cea.fr](mailto:mathieu.lobet@cea.fr))

SFP Division Plasma  
June 14th 2018



# Lab and speaker presentation

## Maison de la Simulation (Saclay)

### Missions:

- Research in HPC, Applied Math, visualization
- Support to the scientific community
- Training (national, Prace)

Involved in national and European projects: EoCoE, Prace



### Mathieu Lobet:

Research Engineer in HPC at CEA Saclay

### Projects:

- Energy oriented Centre of Excellence for computing application (EoCoE)

### Applications:

- SMILEI – High performance Particle-In-Cell code for plasma simulation
- TOKAM3X - Edge turbulence fluid simulations of tokamak plasmas



# Content

I. The Exascale challenge

II. Future hardware

III. Programming challenges

Conclusion



# I. The Exascale challenge



# Exascale challenge

To Reach the **exaflop computing power** ( $10^{18}$  flop/s) level with a maximum electricity consumption of **20-40 Mwatts**

Main sources of energy consumption:

- Computing units (~50% of the total power consumption on most recent facilities)
- Interconnect
- Memory



USA – Aurora at  
Argonne  
2021



Europe  
2022



China  
2019-2020



Japan – Post-K  
computer  
2021



# Most powerful supercomputer analysis, Nov 2017

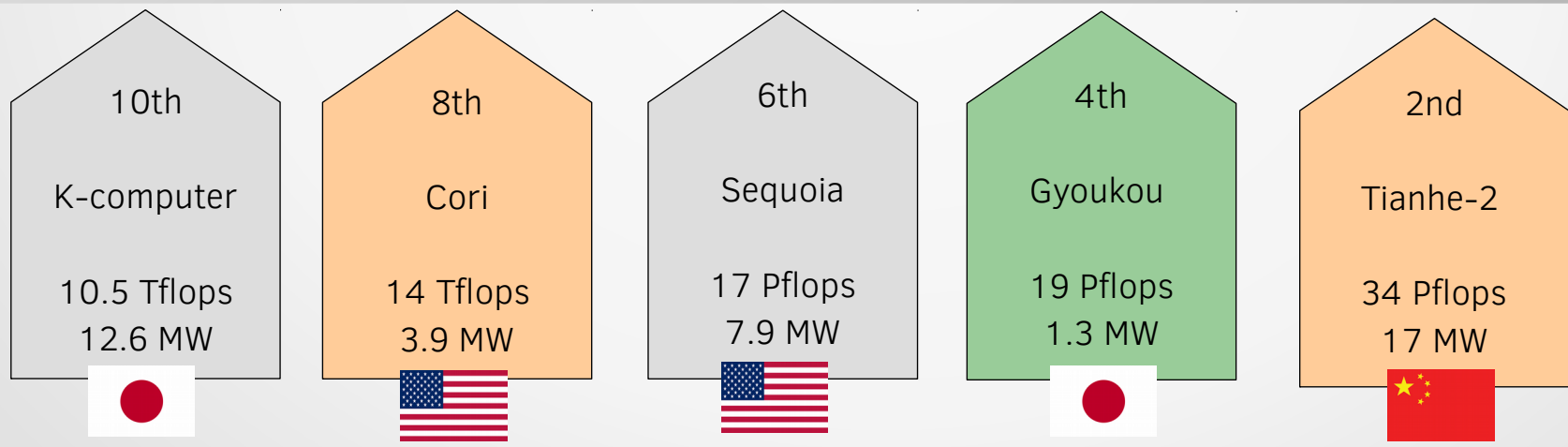
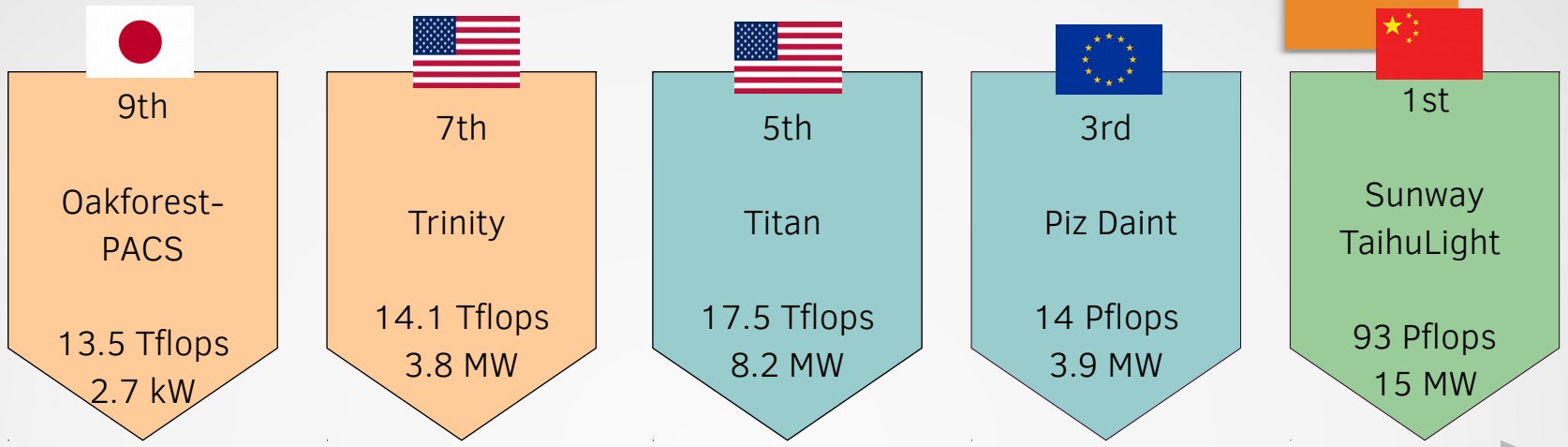

- Multi-core only (ex: Xeon, Power, SPARC)
- Many-core only (ex: Xeon Phi)
- CPU + GPU
- CPU + Acc ARM

<https://www.top500.org/lists/2017/11/>



# Is this the continuity?

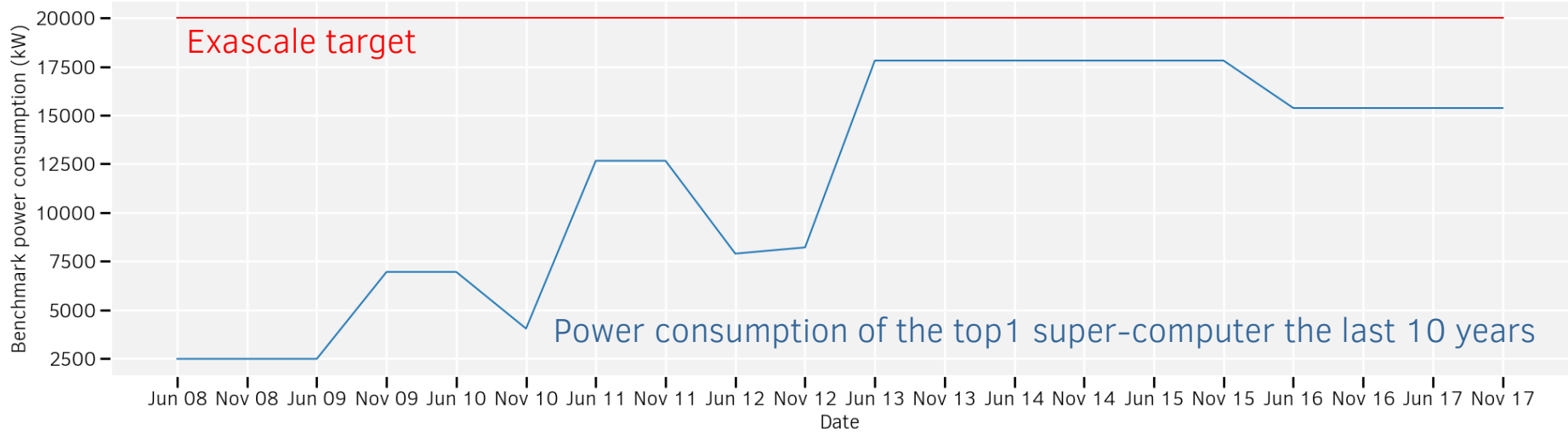
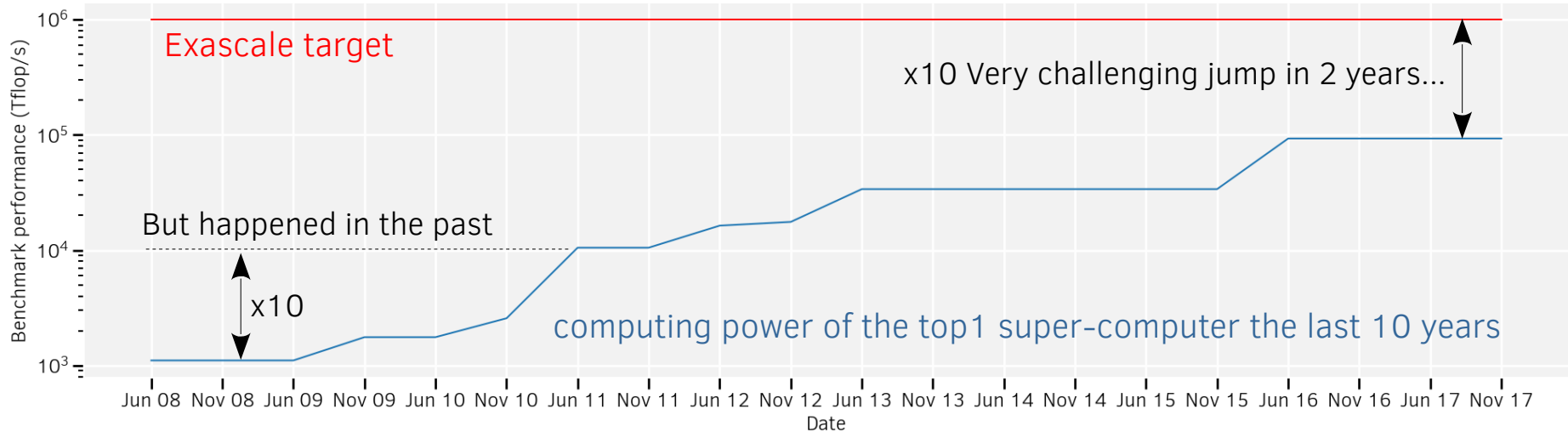





## II. Future Hardware



# X86 (Intel, AMD) and Power CPU (central processing unit)

For Intel and AMD:

- ▶ Historically, complex processing units originally dedicated to **multiple different purposes**
- ▶ In personal computers, **a lot of silicon dedicated to complex instruction sets to be performant in major cases (operating system, web, office software, video...)**
- ▶ Disadvantage in HPC, results in a **bad energy efficiency**
- ▶ For few years now, specific processors for server and HPC purposes such as **Intel Xeon and Intel Xeon Phi** that integrates **smaller and simpler energy efficient cores with low frequency and larger vector units.**

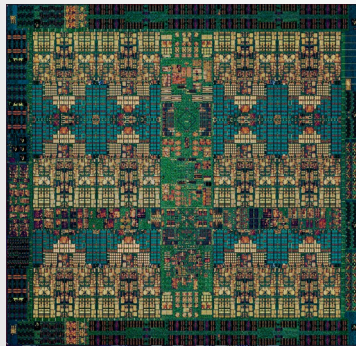

IBM Power9  
Up to 32 cores, up to 4 Ghz, SMT4 – SMT8, 190 W



AMD Epyc 7000 series  
32 cores, base 2.2 Ghz, 180W

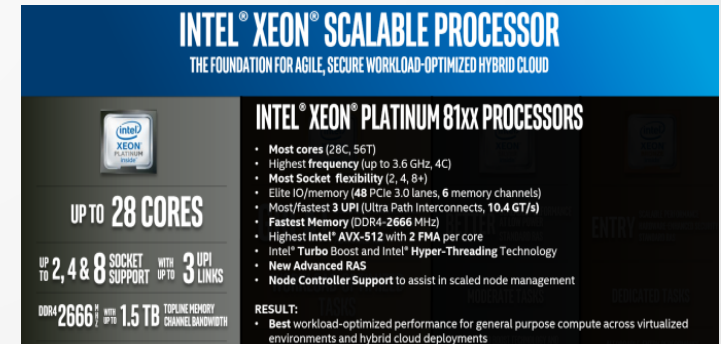

Intel Xeon Skylake  
28 cores, base 1.5 Hhz, 200W, AVX512

[www.microway.com/knowledge-center-articles/detailed-specifications-of-the-skylake-sp-intel-xeon-processor-scalable-family-cpus/](http://www.microway.com/knowledge-center-articles/detailed-specifications-of-the-skylake-sp-intel-xeon-processor-scalable-family-cpus/)

[www.anandtech.com/show/11544/intel-skylake-ep-vs-amd-epyc-7000-cpu-battle-of-the-decade/7](http://www.anandtech.com/show/11544/intel-skylake-ep-vs-amd-epyc-7000-cpu-battle-of-the-decade/7)

<https://www.nextplatform.com/2017/12/05/power9-to-the-people/>



# X86 (Intel, AMD) and Power CPU (central processing unit)

## Pros:

- ▲ Easy to program
- ▲ Easy to debug
- ▲ Cross-platform

## Cons:

▼ For the moment, not suitable for Exascale standalone due to high energy consumption

## Configuration for HPC:

- Host
- Accelerators for Xeon Phi

## Programming models available:

- C, C++, Fortran
- Vendor compilers
- LLVM, GNU
- MPI, OpenMP, OpenCL

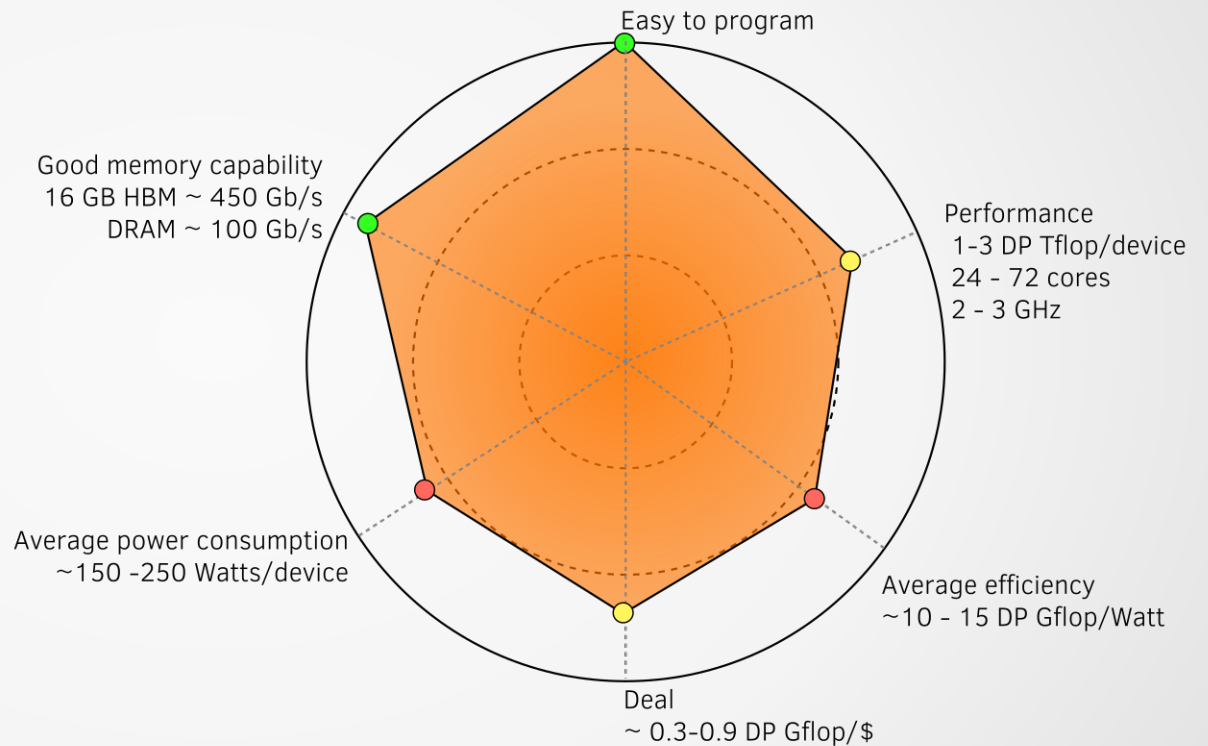

Based on Xeon Skylake and Xeon Phi KNL characteristics

[www.microway.com/knowledge-center-articles/detailed-specifications-of-the-skylake-sp-intel-xeon-processor-scalable-family-cpus/](http://www.microway.com/knowledge-center-articles/detailed-specifications-of-the-skylake-sp-intel-xeon-processor-scalable-family-cpus/)

[www.anandtech.com/show/11544/intel-skylake-ep-vs-amd-epyc-7000-cpu-battle-of-the-decade/7](http://www.anandtech.com/show/11544/intel-skylake-ep-vs-amd-epyc-7000-cpu-battle-of-the-decade/7)

<https://www.nextplatform.com/2017/12/05/power9-to-the-people/>



# RISC-based processors such as ARM

Historically, ARM processor uses the **light and less complex RISC architecture** (Reduced Instruction Set Computing) that does not contain complex instruction sets enabling **low energy consumption per core, less silicon and cheaper chips**.

ARM was initially designed for embedded and mobile applications.

Europe (Mont-Blanc, CEA, Bull) and Japan (RIKEN) are now pushing the development of ARM super-computers.

Post-K: Fujitsu HPC CPU to Support ARM v8

Post-K fully utilizes Fujitsu's proven supercomputer microarchitecture  
 Fujitsu, as a "lead partner" of ARM HPC extension development, is working to realize an ARM Powered® supercomputer w/ high application performance  
 ARM v8 brings out the real strength of Fujitsu's microarchitecture

HPC apps acceleration feature	Post-K	FX100	FX10	K computer
FMA: Floating Multiply and Add	✓	✓	✓	✓
Math. acceleration primitives*	✓Enhanced	✓Enhanced	✓	✓
Inter core barrier	✓	✓	✓	✓
Sector cache	✓Enhanced	✓Enhanced	✓	✓
Hardware prefetch assist	✓Enhanced	✓Enhanced	✓	✓
Tofu interconnect	✓Integrated	✓Integrated	✓	✓

\* Mathematical acceleration primitives include trigonometric functions, sine & cosines, and exponential function

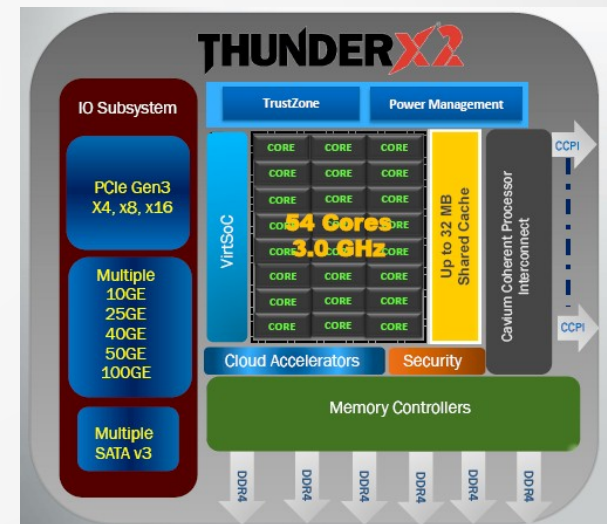
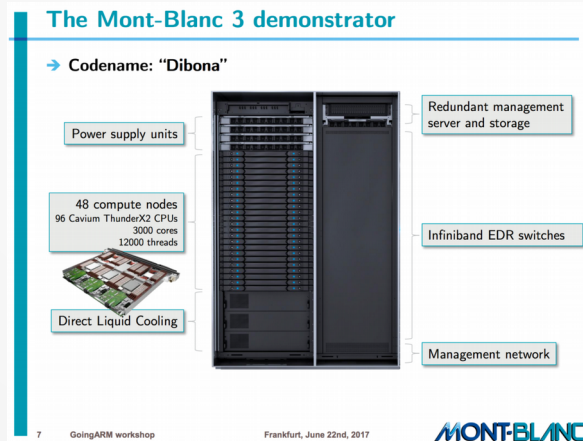

Post K-computer, a Japanese candidate for Exascale, will be equipped of ARMv8 with SVE ISA. (<http://www.fujitsu.com/global/Images/post-k-supercomputer-overview.pdf>)

European Bull DIBONA prototype uses Cavium ThunderX2 ARM cards in the framework of the European Mont-Blanc project. (<http://montblanc-project.eu/prototypes>)

ARM based server Cavium ThunderX2 used in DIBONA. ([www.nextplatform.com/2016/06/03/next-generation-thunderx2-arm-targets-skylake-xeons/](http://www.nextplatform.com/2016/06/03/next-generation-thunderx2-arm-targets-skylake-xeons/))

- <http://laruche.it/2014/07/05/lqt-cpu-arm-x86-differences-549851>
- <https://www.androidauthority.com/arms-secret-recipe-for-power-efficient-processing-409850/>
- <https://www.servethehome.com/cavium-thunderx2-review-benchmarks-real-arm-server-option/>



# RISC-based processors such as ARM

## Pros:

- ▲ Few code modifications from x86
- ▲ Server-oriented ARM SoC **cheaper** than Intel x86 CPUs
- ▲ Sell as licence: possibility to manufacture in Europe
- ▲ Easy to debug

## Cons:

- ▼ **Not really more efficient than x86 for the moment** if strong scalable vector usage
- ▼ Server-oriented ARM **TDP tends to reach Intel x86 CPUs due to increased core complexity for HPC**
- ▼ **More optimization** let to the compilers and the developers **to get performance**

## Configuration for HPC:

- Host
- Replace the x86 CPUs

## Programming model available:

- Same as for x86 CPU architecture (C, C++, Fortran, LLVM, GNU, MPI, OpenMP...)

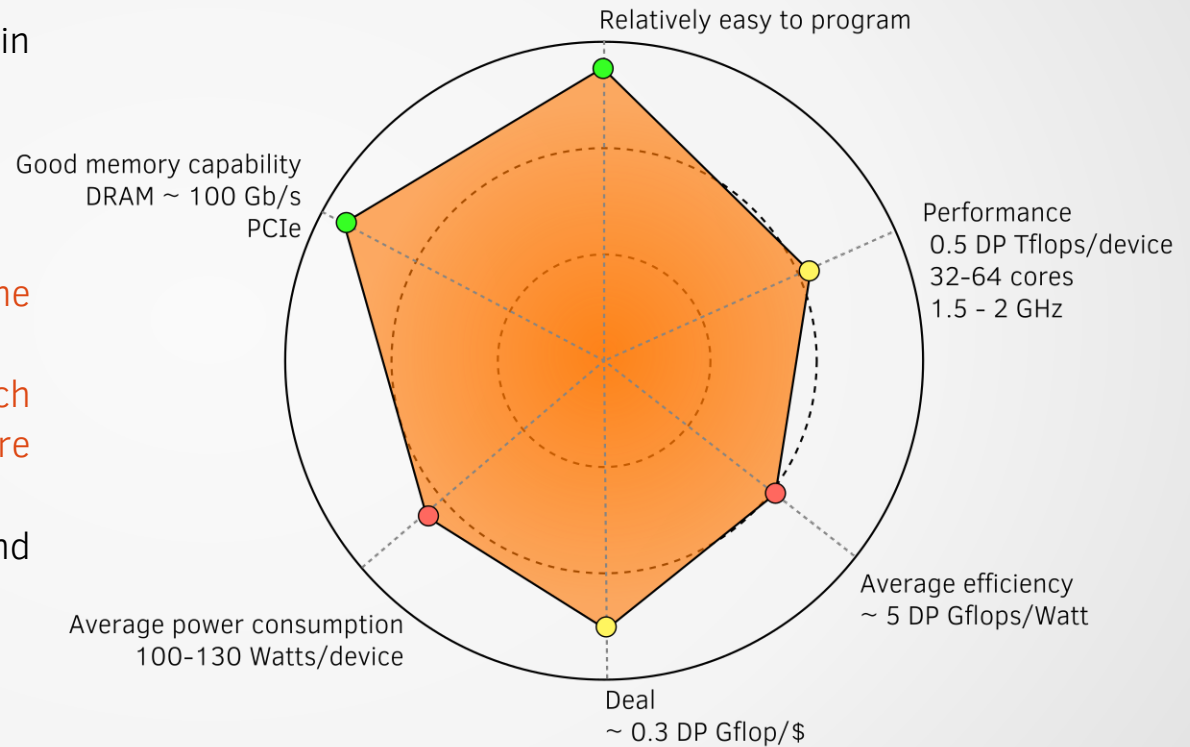

Based on Cavium, Ampere, Centric 2400 and Phytium Mars characteristics





# GPGPU (General Purpose Graphic Processing Units)

Historically, GPUs are used for complex graphical rendering in PC.

- ▶ need a lot of small simple computing units working in parallel

In the early 2000's, GPUs start to overcome CPU computational power and the gap is still increasing today.

- ▶ appeared to be excellent candidate for HPC

Today, GPUs are **massively parallel and vector devices composed of a lot of very simple and small cores (> 1000)** contrary to CPUs composed of a small number of more complex cores.

- ▶ How to parallelize an algorithm is a different way of thinking

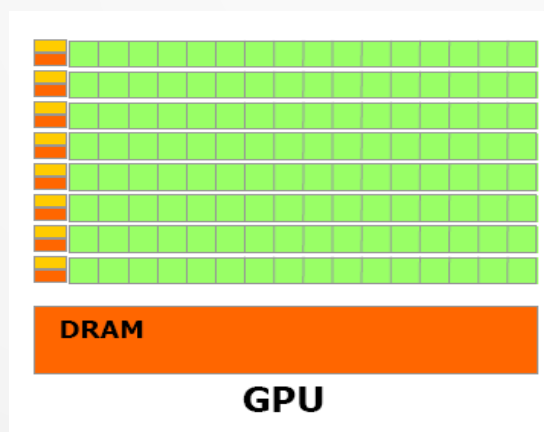
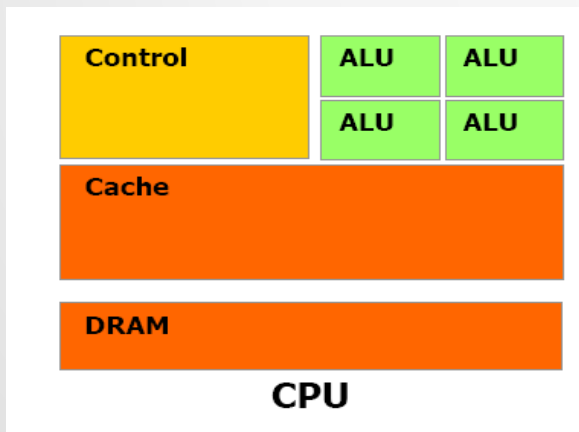

Nvidia Tesla P100 Streaming Multiprocessor (SM) architecture

<https://images.nvidia.com/content/pdf/tesla/whitepaper/pascal-architecture-whitepaper.pdf>

<https://devblogs.nvidia.com/inside-pascal/>

[http://www.info2.uqam.ca/~makarenkov\\_v/BIF7002/Rapport\\_Arhjoul.htm](http://www.info2.uqam.ca/~makarenkov_v/BIF7002/Rapport_Arhjoul.htm)



# GPGPU (General Purpose Graphic Processing Units)

## Pros:

- ▲ Good performance in a single device (Desktop HPC application)
- ▲ Relatively easy to debug
- ▲ More and more easy to program

## Cons:

- ▼ Important adaptation efforts depending on the algorithm
- ▼ Important optimization efforts for decent performance

## Configuration for HPC:

- Accelerator

## Programming models available:

- CUDA, OpenCL, OpenACC, OpenMP

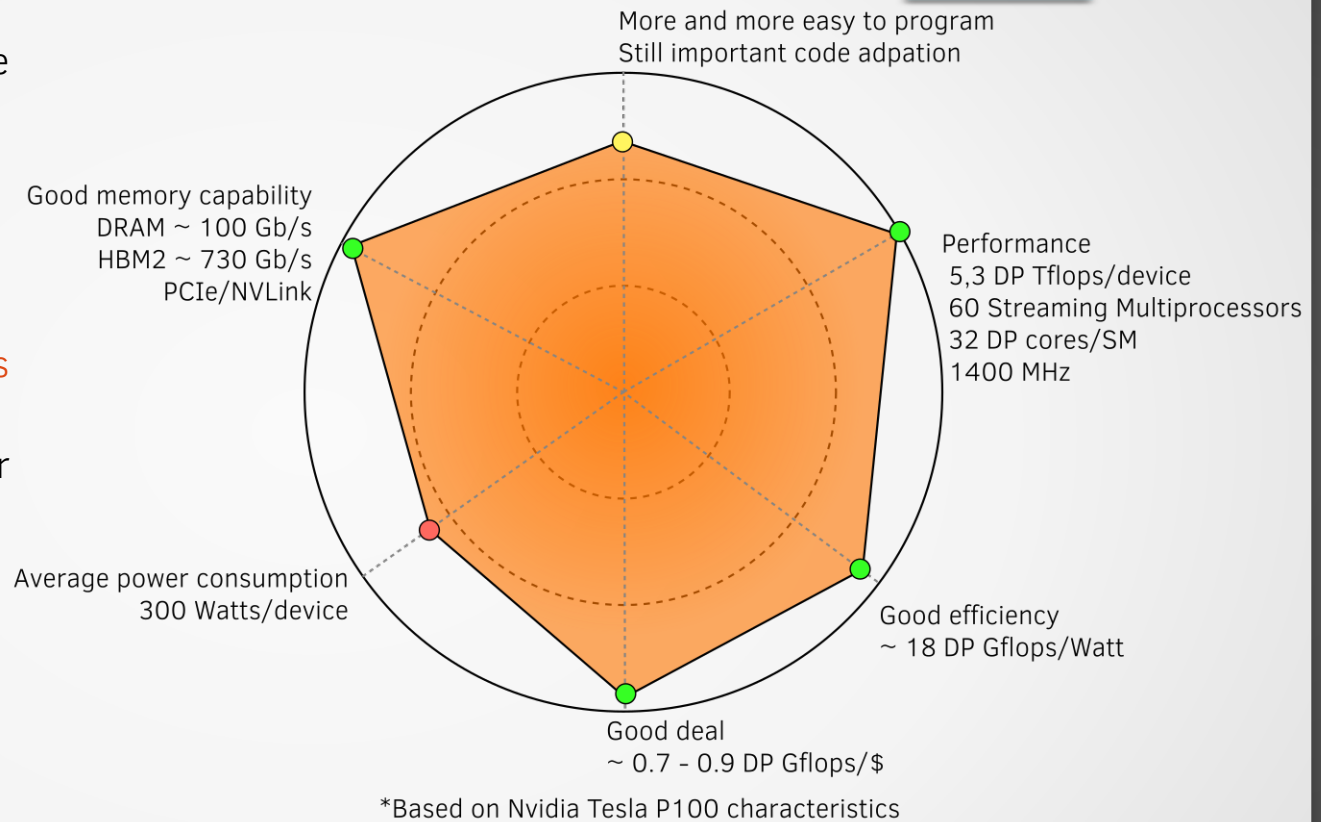

<https://images.nvidia.com/content/pdf/tesla/whitepaper/pascal-architecture-whitepaper.pdf>

<https://devblogs.nvidia.com/inside-pascal/>

[http://www.info2.uqam.ca/~makarenkov\\_v/BIF7002/Rapport\\_Arhjoul.htm](http://www.info2.uqam.ca/~makarenkov_v/BIF7002/Rapport_Arhjoul.htm)



# FPGA - Field Programmable Gate Arrays

FPGA an **integrated circuit designed to be configured**: an array of programmable logic blocks and reconfigurable interconnects.

The FPGA architecture provides the flexibility to create a **massive array of application-specific ALUs** that enable both instruction and data-level parallelism.

Very high energy efficiency because of low frequency, a lot of silicon dedicated to the computation, unused blocs does not consume energy.

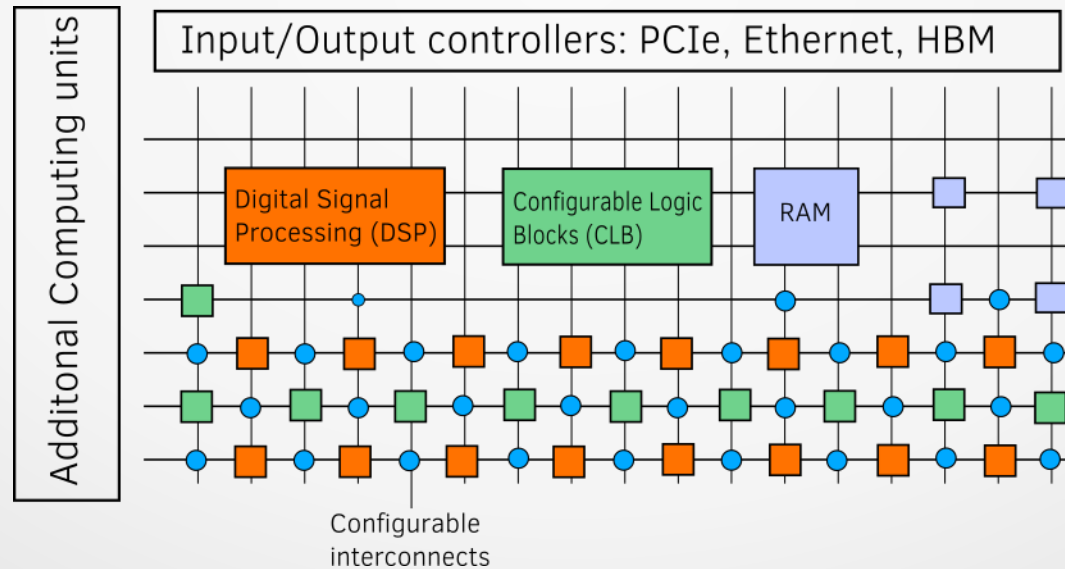

[https://science.energy.gov/~media/ascr/ascac/pdf/meetings/201612/Finkel\\_FPGA\\_ascac.pdf](https://science.energy.gov/~media/ascr/ascac/pdf/meetings/201612/Finkel_FPGA_ascac.pdf)  
[https://www.xilinx.com/support/documentation/white\\_papers/wp375\\_HPC\\_Using\\_FPGAs.pdf](https://www.xilinx.com/support/documentation/white_papers/wp375_HPC_Using_FPGAs.pdf)  
<https://www.altera.com/products/fpga/stratix-series/stratix-10/overview.html>





# FPGA - Field Programmable Gate Arrays

### Pros:

- ▲ Best energy efficiency (flop/Watt) on the market
- ▲ Versatile and adaptable to many kernels

### Cons:

- ▼ Difficult to program today
- ▼ Low frequency (~100 MHz) ► pipelining optimization and vectorization
- ▼ Long compilation (several hours)
- ▼ Debugging ? Emulators ?

### Configuration for HPC:

- as an accelerator

### Programming model available:

- Vendor specific languages (MaxJ language for Maxeler)
- OpenCL with C/C++/Fortran (pushed by Intel)
- OpenMP/OpenACC (not mature)
- VHDL (higher difficulty)

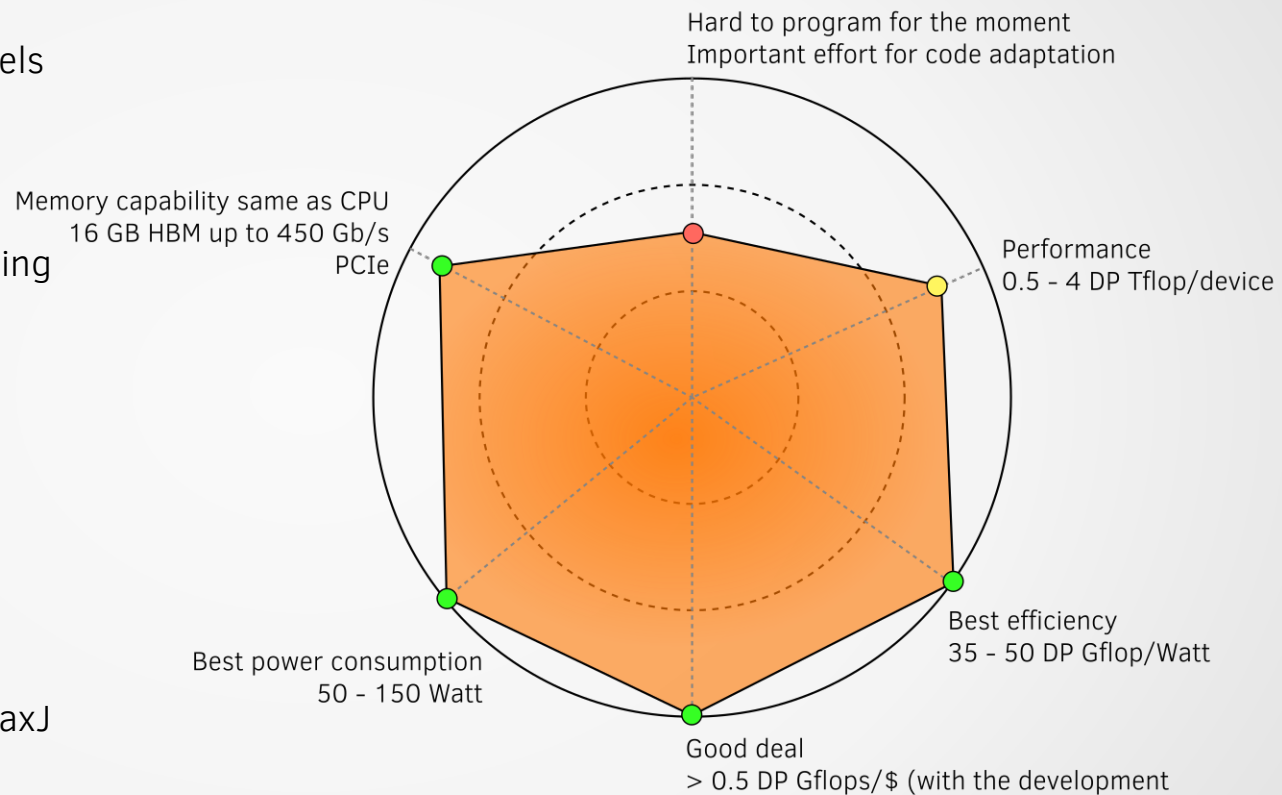

Based on Altera Stratix 10 and Xilinx Virtex Ultrascale+ characteristics

[https://science.energy.gov/~media/ascr/ascac/pdf/meetings/201612/Finkel\\_FPGA\\_ascac.pdf](https://science.energy.gov/~media/ascr/ascac/pdf/meetings/201612/Finkel_FPGA_ascac.pdf)  
[https://www.xilinx.com/support/documentation/white\\_papers/wp375\\_HPC\\_Using\\_FPGAs.pdf](https://www.xilinx.com/support/documentation/white_papers/wp375_HPC_Using_FPGAs.pdf)  
<https://www.altera.com/products/fpga/stratix-series/stratix-10/overview.html> ; <https://indico.math.cnrs.fr/event/3435/material/slides/0.pdf>



# Processing unit general view

No miracle so far...



- Programmed FPGA
- GPGPU
- Xeon Phi Power
- Xeon SP ARMv8
- Xeon ARM
- Pentium AMD Bulldozer



# Hardware trends: multi-level massive parallelism

Exascale supercomputers will be composed of more than 100 000 interconnected nodes (several millions cores).

Level 1 – distributed parallelism between node

↔ MPI still the considered communication model for developers

▲ Complex software stack required to handle huge traffic and failure (lossless compression, resilience, huge pages, RMA...)

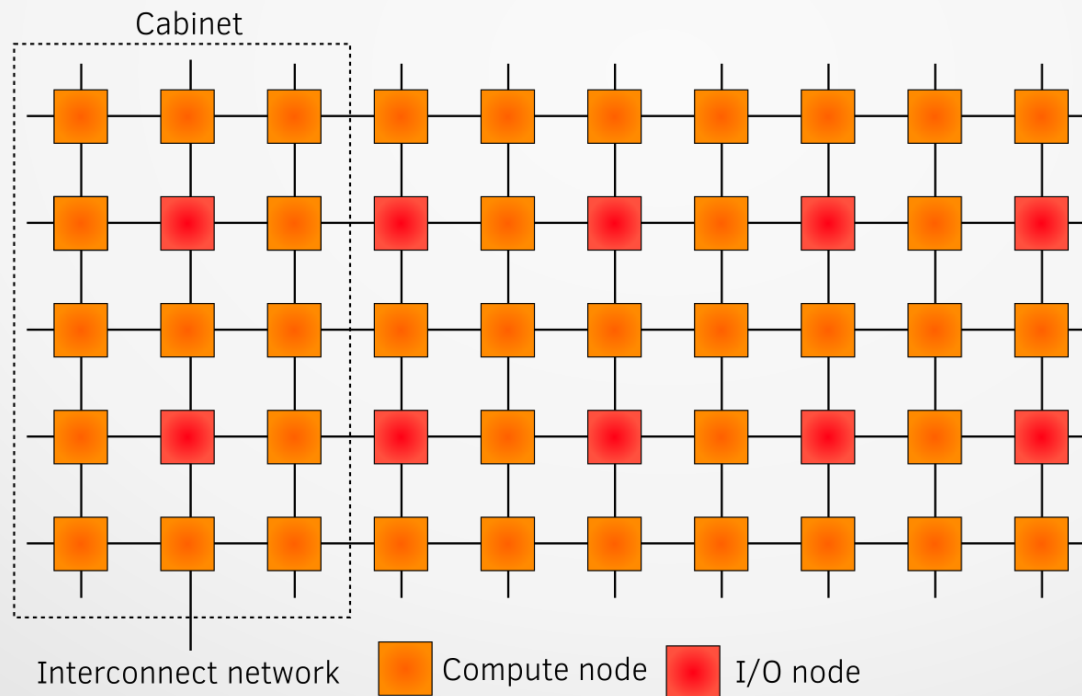



# Hardware trends: multi-level massive parallelism

Each node composed of several sockets of **several tens of cores/threads** potentially connected to **1 or more accelerators**

Level 2 – inner-node parallelism

↔ Shared parallelism with non-uniform memory access (NUMA) between cores or sockets

■ Heterogeneous computing with different accelerators, memory space and bandwidth

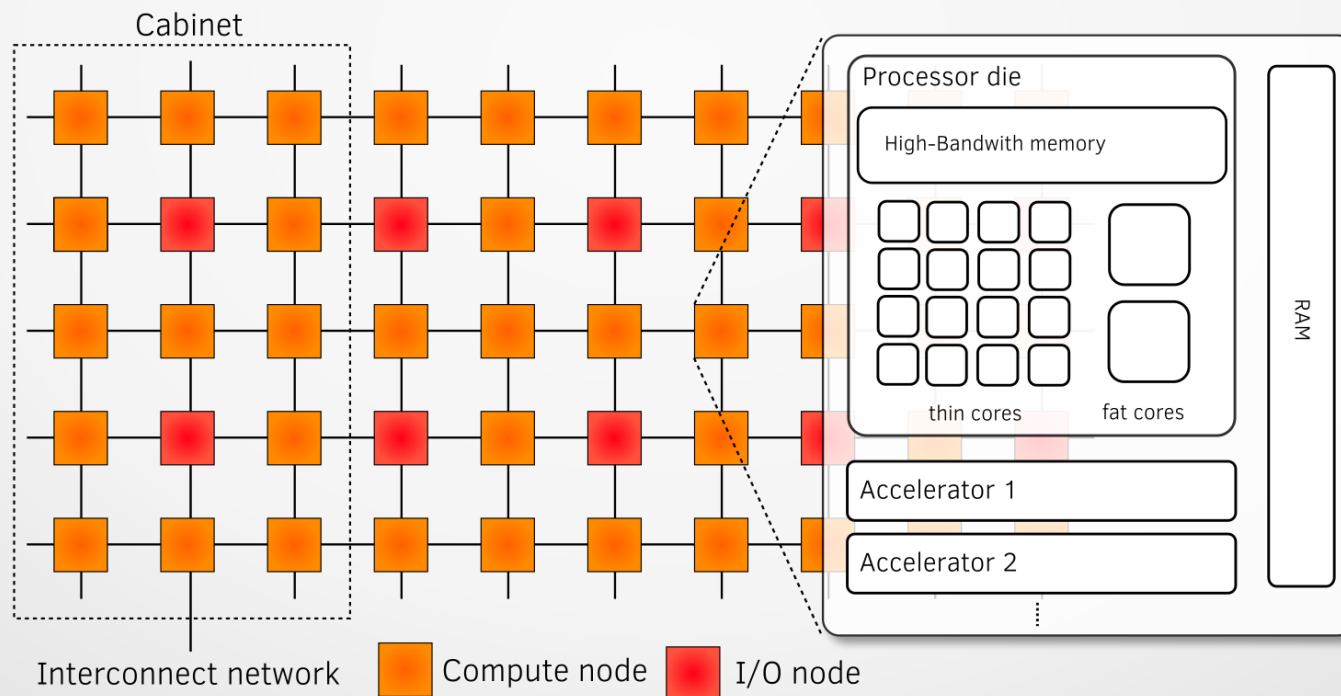



# Hardware trends: heterogeneity

## Frontal nodes

Role: OS

Processing units: Server x86 (Xeon), Power, ARM

## Compute node

### Host

Multi-core x86, Power, ARM CPUs

Many-core x86, Power, ARM CPUs

Skinny-Fat x86

Big.LITTLE ARM

RAM

Role: OS, computation, post-processing, software  
Programming model: MPI, OpenMP...

PCIe,  
NVLINK...

Unified  
memory

### Accelerators

Co-processors (Many-core), PEZY, MATRIX-2000

GPGPU

FPGA

HBM

Role: computation, post-processing, rendering  
Programming model: OpenCL, CUDA, OpenACC, OpenMP...

## I/O nodes

Role: OS, computation, post-processing, software, IO treatment

Programming model: MPI, IO stack



# High-speed interconnect: openPOWER example

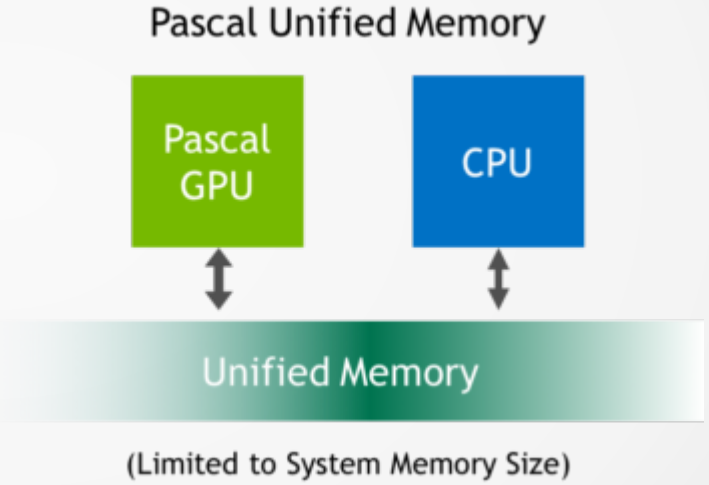
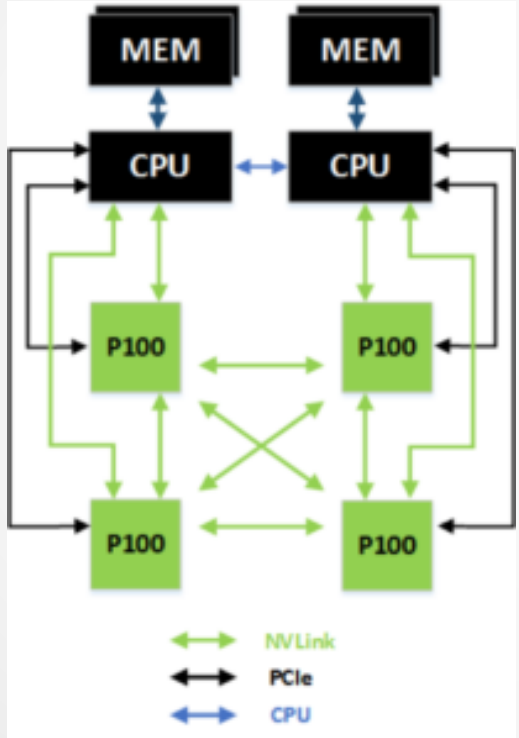



# Hardware trends: vectorization

All computing devices can be seen as a vector machine

Level 3 – vectorization

▣ Capability to compute simultaneously a full vector of data with the same set of operations

CPU: **Single instruction multiple data** (SIMD) vectorization

GPU: vectorization through the large number of cores working simultaneously within a SM: **Single instruction multiple thread vectorization** (SIMT)

FPGA: vectorization through kernel encoding replica: several pipelines of the same kernel working simultaneously

For i from 1 to N :

If (condition on i) :

$$d[i] = a[i] + b[i]*c[i]$$

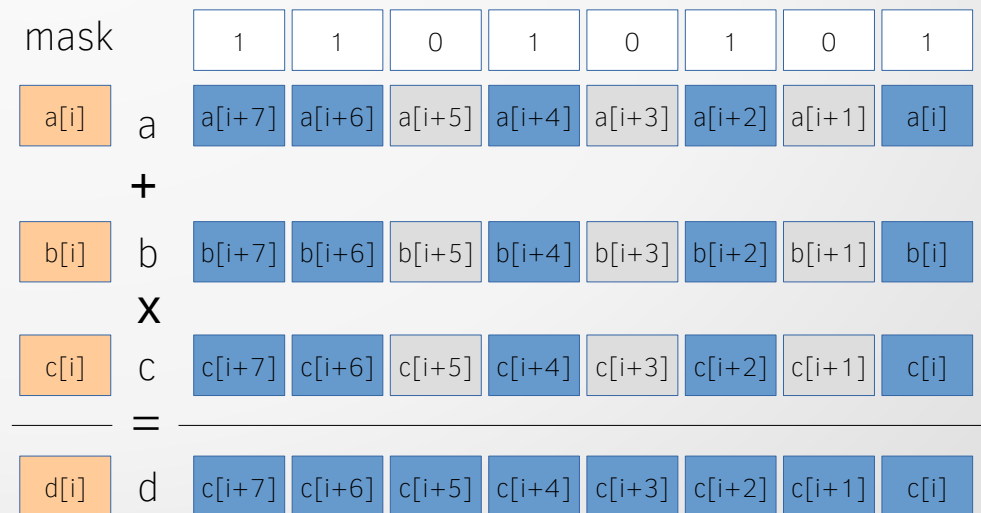

Single Instruction Multiple Data SIMD vision as in x86 Intel



# Hardware trends: vectorization

All computing devices can be seen as vector machines

Level 3 – vectorization

▣ Capability to compute simultaneously a full vector of data with the same set of operations

CPU: **Single instruction multiple data (SIMD)** vectorization

GPU: vectorization through the large number of cores working simultaneously within a SM: **Single instruction multiple thread vectorization (SIMT)**

FPGA: vectorization through kernel encoding replica: several pipelines of the same kernel working simultaneously

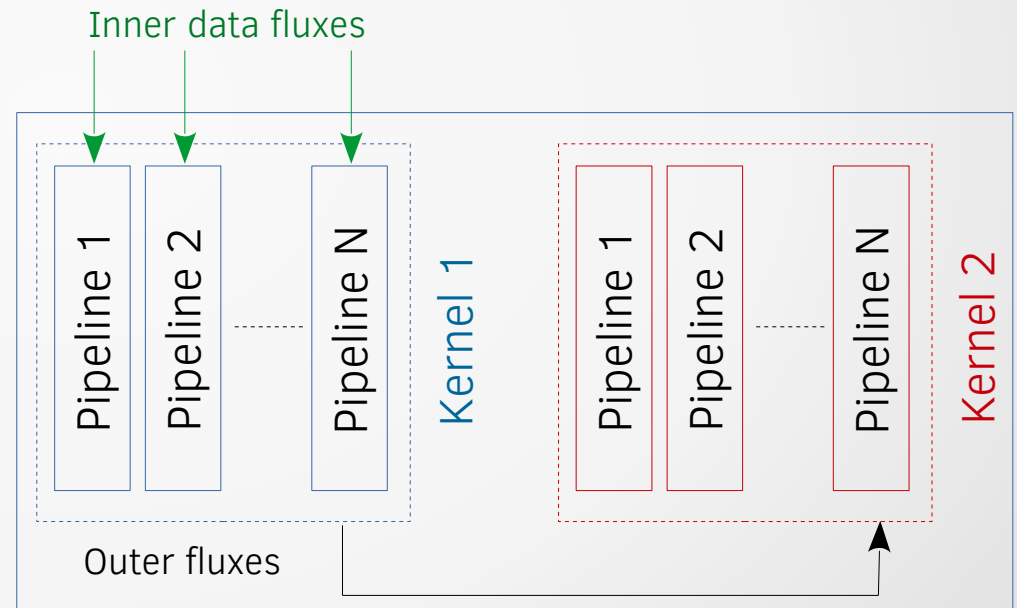

FPGA pipeline vectorization by the multiplication of the a pipeline from the same kernel





# Hardware trends: I/O nodes

I/O nodes are specialized in fast input / output with a complex storage hierarchy

DRAM: volatile, highest bandwidth ( $\sim 100\text{Gb/s}$ ), lowest capacity ( $\sim 10\text{Gb}$ )

Storage Class Memory (SCM): volatile, lower bandwidth than DRAM ( $\sim 10\text{Gb/s}$ ) but higher capacity ( $\sim 100\text{Gb}$ )

SSD: also referred to as burst buffer, permanent, lower bandwidth ( $\sim \text{Gb/s}$ ) than SCM but higher capacity ( $\sim 500\text{Gb}$ )

HDD: permanent, lowest bandwidth ( $\sim 100\text{Mb/s}$ ), highest capacity ( $\sim \text{Tb}$ )

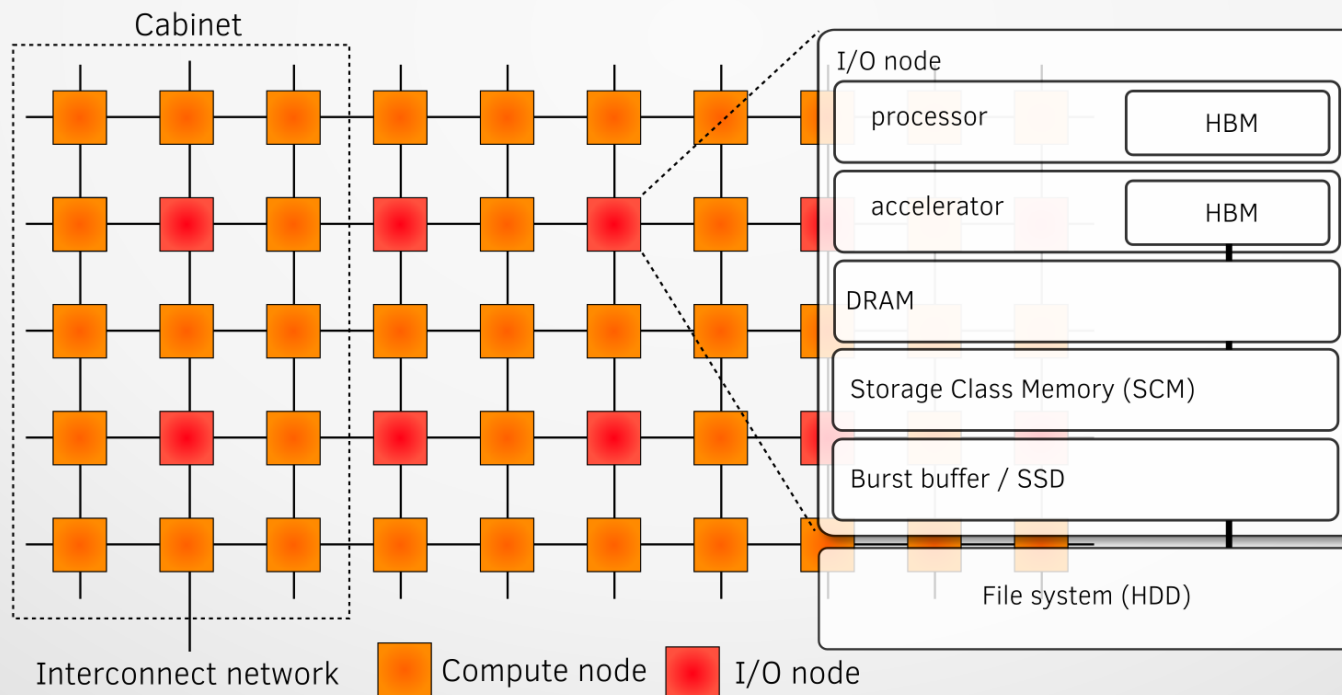



### III. Programming challenges



## Presentation of the codes



Smilei)

LULI, LLR, CEA Saclay

Smilei is a Particle-In-Cell code for plasma simulation. Open-source, collaborative, user-friendly and designed for high performances on CPU super-computers, it is applied to a wide range of physics studies: from relativistic laser-plasma interaction to astrophysics.

- ▶ Python + C++
- ▶ MPI + OpenMP
- ▶ HDF5 + OpenPMD

△ <http://www.maisondelasimulation.fr/smilei/>

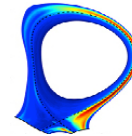

Tokam3X

CEA Cadarache

The TOKAM3X code simulates both limited and diverted plasma turbulence in full torus Tokamak geometry including the open field lines of the Scrape-off Layer (SOL) and the edge closed field lines region in the vicinity of the separatrix.

- ▶ Fortran
- ▶ MPI + OpenMP
- ▶ HDF5 sequential



# Programming challenges – multi-level massive parallelism

Time spent in communication will overcome computational time (almost the case for SMILEI)  
Network capacity evolves less rapidly than computation power

Scalability:

- ▶ MPI + X (OpenMP, Open ACC...)
- ▶ Limit data movements, avoid global communications, use shared memory within a node
- ▶ Use non-blocking communication with computation
- ▶ Dedicate cores to the communications, diagnostic processing, I/O
- ▶ Use accelerator in symmetric mode to exploit the full node computational power

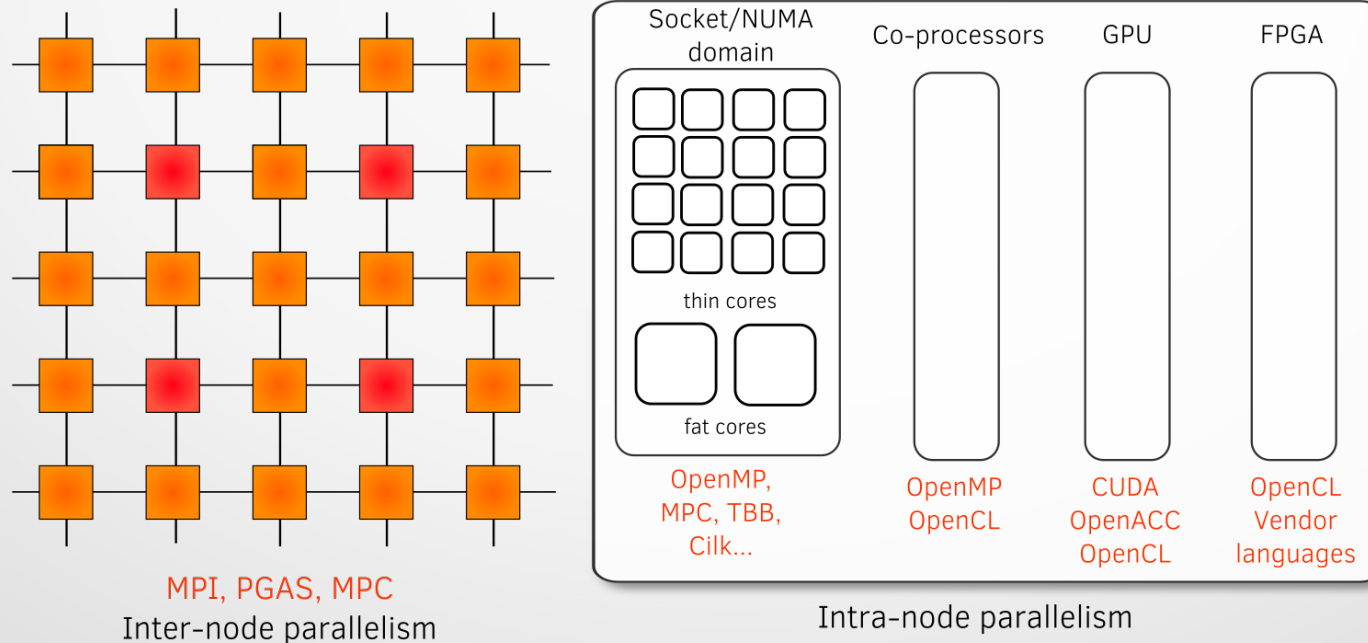



# Programming challenges – architecture dependency

## How to deal with architecture multiplication?

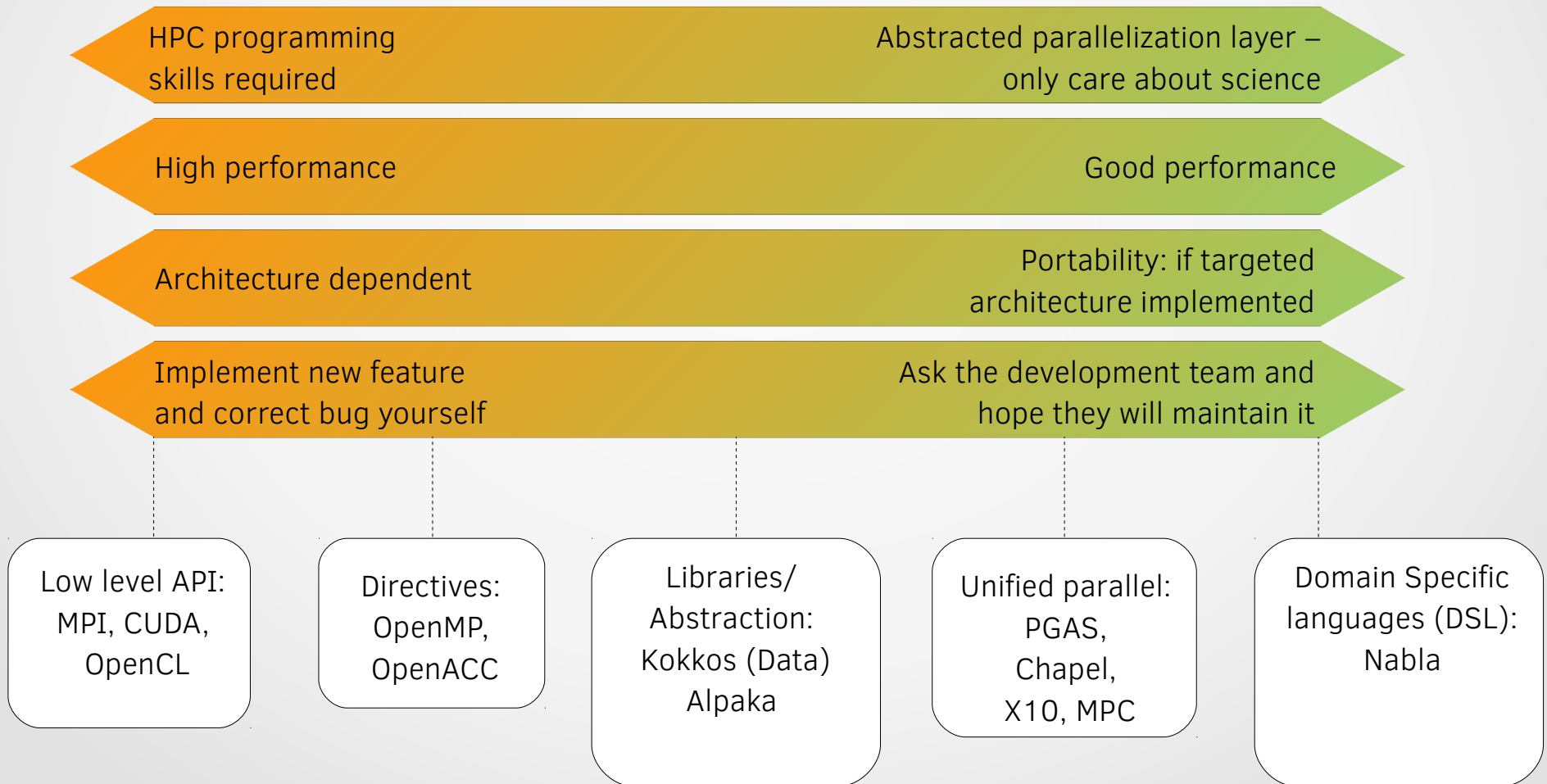



# Programming challenges – Task-based approach

- ▶ An application can be divided temporally and spatially into inter-dependent tasks of different natures (computation, communication, IO)
- ▶ Using a smart runtime scheduler, tasks can then be run **concurrently/asynchronously in parallel on a large number of cores/ on several architectures.**
- ▶ To use a task-based model can speedup the code by overlapping IO and communication with computation.
- ▶ Factor of performances: grain size (fine, coarse), scheduler, dependency graph
- ▶ OpenMP task, StarPU, libKOMP...

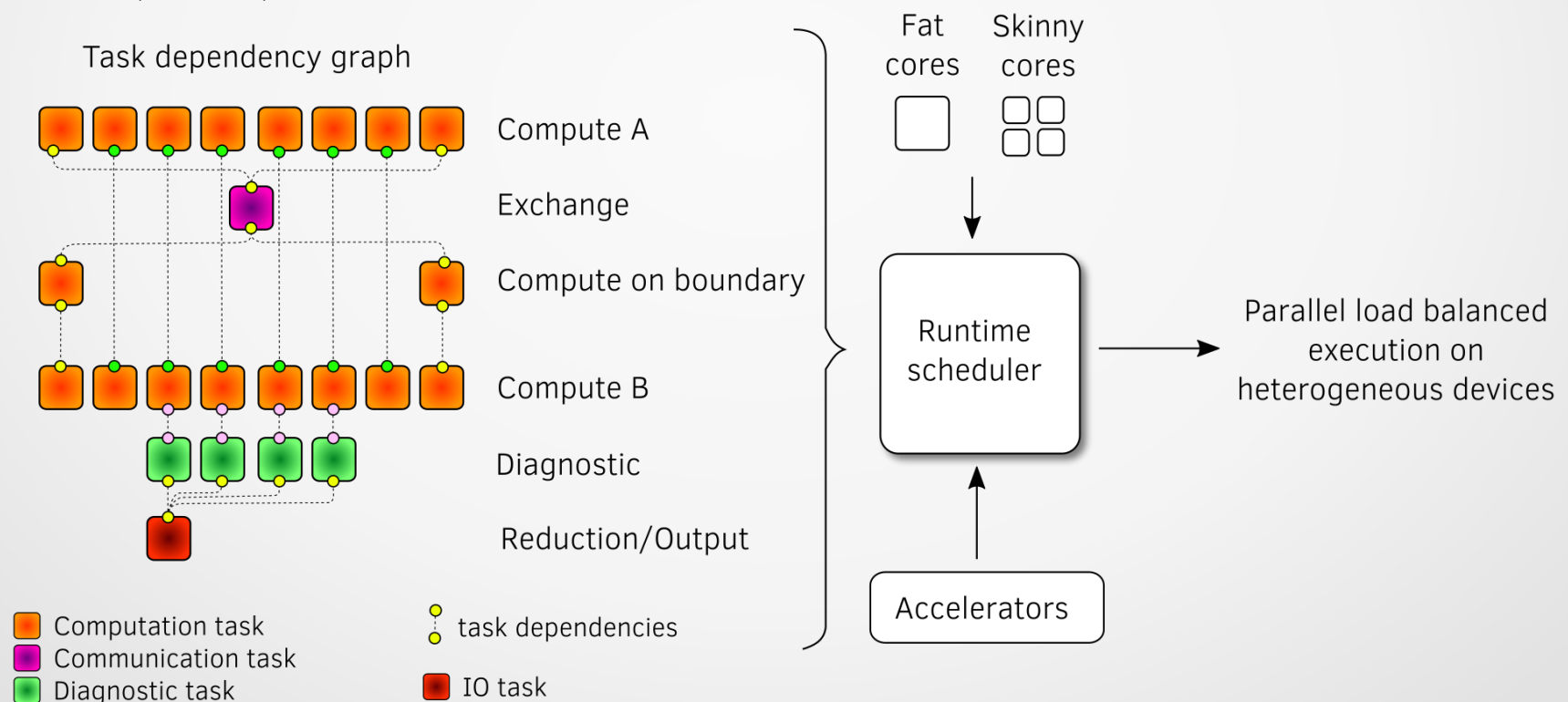



# Programming challenges – cache blocking + vectorization

Decomposition of the workload into chunk that fit the targeted level of cache :

- ▶ Diminish number of cache misses / reuse data in cache
- ▶ Reduce memory bandwidth pressure : improve performance of memory bound algorithms

Hybrid parallel memory decomposition

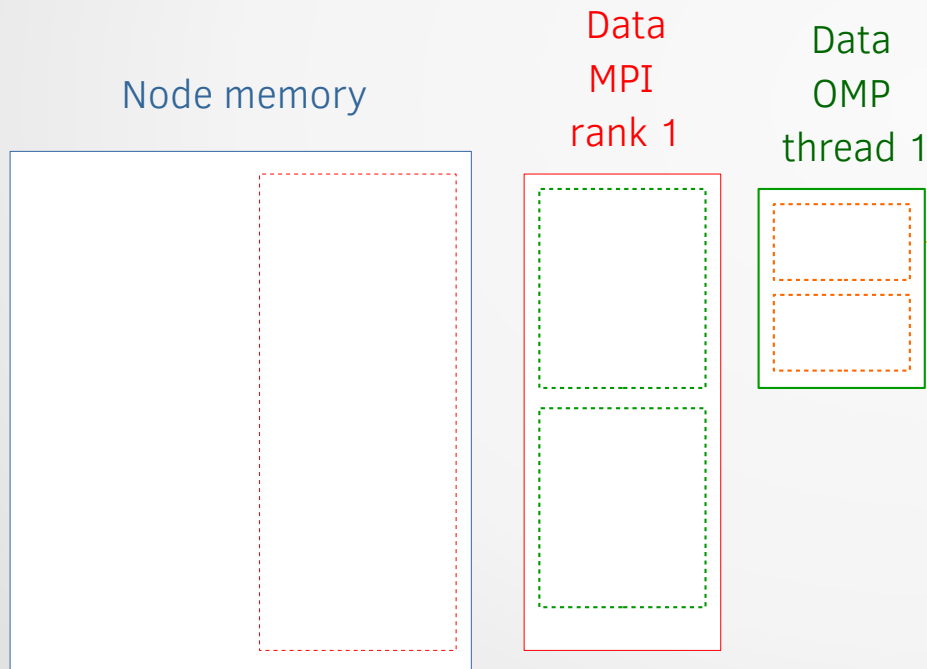

Cache blocking

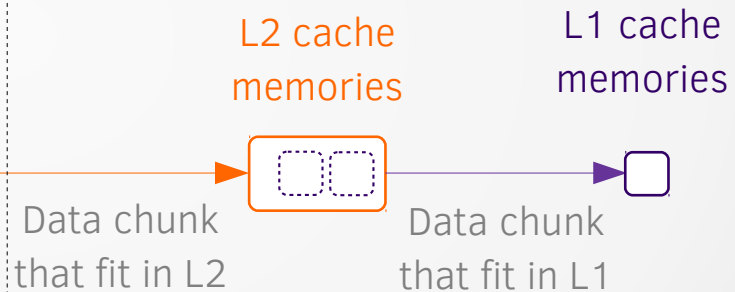

Chunk size < L2

Chunk number > number of OMP thread



# Programming challenges – IOs

- ▶ Dealing with specific IO nodes
- ▶ Dealing with complex IO hardware stack
- ▶ Scalable and concurrent reading/writing process
- ▶ Portability / Flexibility
- ▶ Checkpointing for fault tolerance
- ▶ Storage capacity increases less rapidly than computational power: data treatment on the fly, in-situ visualization, in-situ analysis via machine learning

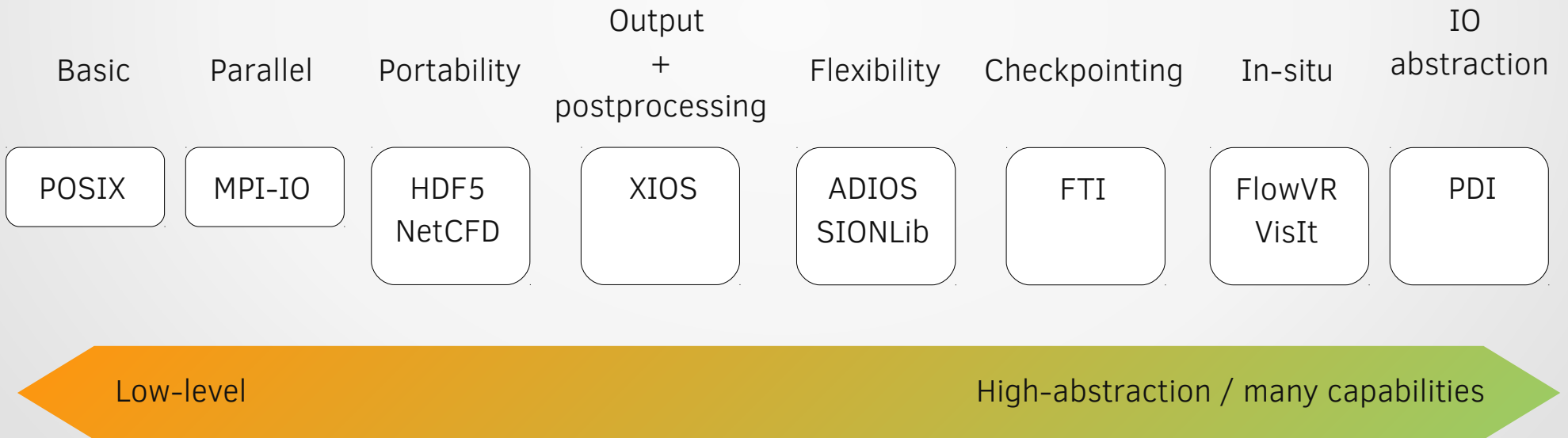





## Additional challenging aspects not covered here

- ▶ Code output precision (how to tune precision to speed-up the code)
- ▶ Failure prediction and correction
- ▶ Code optimization to reduce energy-consumption (not just a question of computer design)



## Conclusion

- ▶ **No breakthrough expected**, forthcoming HPC hardware is the continuity or adapted from other domains such as the mobile world
- ▶ **Scalability on millions of core will be challenging**: multi-level parallelism, communication limitation, communication/computation/diagnostic overlapping, task model
- ▶ **Core optimization**: smart use of cache levels, vectorization
- ▶ **Heterogeneity will be challenging**: concurrent use of resources to reach peak performance (overlapping, task...)
- ▶ **Disk memory will be limited and IO stack more complex**: parallel use of IO nodes, dedicated resources to diagnostics and IOs, asynchronous treatment taking advantage of intermediate storages
- ▶ **Focusing on a specific architecture can be dangerous** to run efficiently on forthcoming machines
- ▶ Exascale optimization efforts useful for current architecture as well