



**HAL**  
open science

## The Radio Direction Finding with Advantage of the Software Defined Radio

Josef Hrabal, David Seidl, Michal Krumnikl, Pavel Moravec, Petr Olivka

► **To cite this version:**

Josef Hrabal, David Seidl, Michal Krumnikl, Pavel Moravec, Petr Olivka. The Radio Direction Finding with Advantage of the Software Defined Radio. 15th IFIP International Conference on Computer Information Systems and Industrial Management (CISIM), Sep 2016, Vilnius, Lithuania. pp.720-728, 10.1007/978-3-319-45378-1\_62 . hal-01637506

**HAL Id: hal-01637506**

**<https://inria.hal.science/hal-01637506>**

Submitted on 17 Nov 2017

**HAL** is a multi-disciplinary open access archive for the deposit and dissemination of scientific research documents, whether they are published or not. The documents may come from teaching and research institutions in France or abroad, or from public or private research centers.

L'archive ouverte pluridisciplinaire **HAL**, est destinée au dépôt et à la diffusion de documents scientifiques de niveau recherche, publiés ou non, émanant des établissements d'enseignement et de recherche français ou étrangers, des laboratoires publics ou privés.



Distributed under a Creative Commons Attribution 4.0 International License

# The Radio Direction Finding with Advantage of the Software Defined Radio

Josef Hrabal, David Seidl, Michal Krumnikl, Pavel Moravec, and Petr Olivka

Department of Computer Science, FEECS, VŠB – Technical University of Ostrava,  
17. listopadu 15, Ostrava, Czech Republic  
{josef.hrabal,david.seidl}@vsb.cz  
{michal.krumnikl,pavel.moravec,petr.olivka}@vsb.cz  
<http://www.cs.vsb.cz>

**Abstract.** The radio-frequency engineering recently has gone through extensive development. Software-Defined Radio (SDR) plays an important role in this development, bringing new possibilities to radio-frequency engineering and enables us to look at existing radio technologies in a new, innovative way. One such technology is a Doppler antenna, which allows us to find the direction from which the radio signal of given frequency is being transmitted. The SDR allows us to design and construct a highly-simplified system based on the Doppler antenna array. This paper deals with the design and implementation of such system used for the localization using the Doppler effect and the tests of the designed Doppler antenna system.

**Keywords:** Radio direction finding, Doppler antenna, Software-defined radio, SDR

## 1 Introduction

*Radio Direction Finding* (RDF) is the measurement of the direction from which a received signal was transmitted. This has many applications in different sectors. The RDF is used for example in the navigation of ships and aircrafts, for tracking wildlife, and to locate not only emergency transmitters but also illegal or interfering ones.

Nowadays, most of the radio frequency bands are occupied. Fast classification and location of the source of an illegal or interfering transmitters could be very helpful, especially when transmitters or networks are being built and maintained. The classification and locating can be simplified thanks to *software defined radio* (SDR).

## 2 Radio Direction Finding

The RDF is nearly as old as radio itself. Earliest experiments in the radio direction finding were carried out by Heinrich Hertz in 1888. Since then many types of radio direction finding techniques were discovered. The most frequently used ones are the Watson-Watt and the Doppler technique.

## 2.1 Watson-Watt radio direction finding system

The first one from the mentioned techniques is older and was introduced by Robert Watson-Watt before the World War II. It utilises an antenna array consisting of four equidistant vertical elements (known as Adcock antenna [8]) and two separated precisely calibrated receivers. The *angle of arrival* (AoA) is then determined from the signals level difference. The presence of two receivers is the main disadvantage of this technique [1].

## 2.2 Doppler radio direction finding system

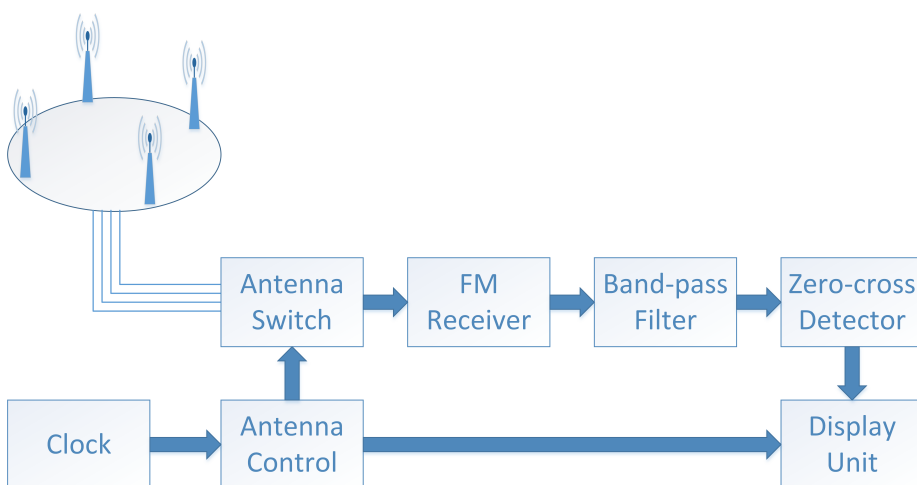

**Fig. 1.** Pseudo-Doppler block diagram

The second technique uses the Doppler effect. This effect was described by Austrian physicist Christian Doppler in 1842 in Prague. Most people associate the Doppler effect with acoustic waves, but the theory is also applicable to radio waves as well. This well known effect describes a difference between the observed and emitted frequency of a wave for an observer which is moving relatively to the source of the waves.

The earliest Doppler direction finding systems used a single antenna placed on a fast rotating turntable. As the receiving antenna approaches the transmitter, the frequency increases and as the antenna recedes from the transmitter, the frequency decreases. The receiver then observes a frequency modulated signal at a rate equal to the frequency of the rotation (rotation tone). The received signal is then de-modulated by FM receiver, which then produces the demodulated rotation tone. The angle of arrival is then determined from the phase offset between the original and the demodulated rotation tone [2].

Spinning the turntable fast enough to produce high frequency signal efficiently is very difficult. Because of this, the physically rotated antenna could be replaced by an antenna array. This array can consist of three or more separate omnidirectional antennas placed evenly along the perimeter of a circle. Each of the antenna is switched successively to make an illusion of the physical rotation. This modified system is known as the Pseudo-Doppler direction finding system and is a result of combination of the Earp and Godfrey system [3] and the Whale system [2].

Block diagram of a simple Pseudo-Doppler direction finding system is shown in the Fig. 1. The Pseudo-Doppler antenna array is located in the top left corner of the image. In this case the array is assembled from four omnidirectional antennas. The antenna array is then connected to the antenna switch. This switch is driven by the antenna control unit and its purpose is to handle sequential switching of the antennas in the array. The radio signal then runs to a FM receiver, where is demodulated. In the next step, the audio output of the receiver is fed into a band-pass audio filter which passes frequencies within a range of rotation tone and rejects frequencies outside that range. To determine the angle of arrival, phase offset of this filtered audio signal is needed. This is carried out by the Zero-cross detector block. In the last step, phase offset of the signal is compared with the rotation tone and the angle of arrival is obtained.

### 2.3 Software Defined Radio

SDR is a radio communication system where components (such as demodulators, filters, amplifiers, etc.) that have been typically implemented in hardware are instead implemented as a software on a personal computer. The concept of SDR is not new, its origins can be tracked back to 1970's. For a long time computers were too slow to accomplish this task. As price of SDR hardware decreased in last years, SDR has gained a lot of popularity and its applications can be found in many sectors.

The main purpose of a SDR receiver is to transform desired frequency to an intermediate frequency and then convert it to digital data by a high speed A/D converter. Result of this process is a stream of digital information which represents the original radio signal by values of its sine and cosine component.

For the testing purposes, we decided to use the 860 MHz band which is regulated by general authorization VO-R/10/05.2014-3 and does not require a licence to use it. Band 860 MHz contains ultra short waves ( $\lambda \sim 35$  cm) which allows us to combine antenna switch and antenna array base easily. The maximum spacing between each separate antenna of the array is limited to less than  $\frac{\lambda}{2}$  [4]. Too small spacing increases mutual coupling between antennas, which in turn increases amplitude directivity of the antennas and reduces the Doppler tone strength in the receiver.

Because we wanted to include more usage scenarios in one design, we decided to make the antenna array as universal as possible. The Pseudo-Doppler antenna array with eight omnidirectional antennas mounted is depicted in Fig. 2. Each



**Fig. 2.** Pseudo-Doppler antenna array

antenna is connected through a SMA connector. This solution allows to mount any number of antennas or use this array only as antenna switch.

The classic antenna switch interconnection uses several passive components. The mechanism of antenna switching is described in [9]. Fig. 3 shows the classic antenna switch circuit of Pseudo-Doppler antenna.

When we use antenna array with only four antennas, this circuit is sufficient. But for a larger number of antennas, the interconnection would become more complicated. Further, it is necessary to ensure that all used electrical components for antenna switching have the same electrical characteristics for each switched antenna. Should the characteristics of the components for individual antennas differ, the accuracy of the whole system would be negatively influenced and the performance of the whole Pseudo-Doppler system would suffer.

The switching element used according to Fig. 3 is a semiconductor diode D7 . . . D14. The highest attainable frequency for antenna switching is dependent on the characteristics of the used diode. When we introduce signal to J1-1 . . . J1-4 connectors, the corresponding antenna is disabled. To control the antenna switch, we need another integrated circuit – a shift register, which ensures the gradual antenna switching with specified frequency.

Our implementation of Doppler antenna array uses eight individual antennas. We have used HMC253 integrated circuit – which is suitable for high-frequency signal switching – to build high frequency electronic antenna switch. The HMC253 integrated circuit is able to process radio signal up to 3.5 GHz

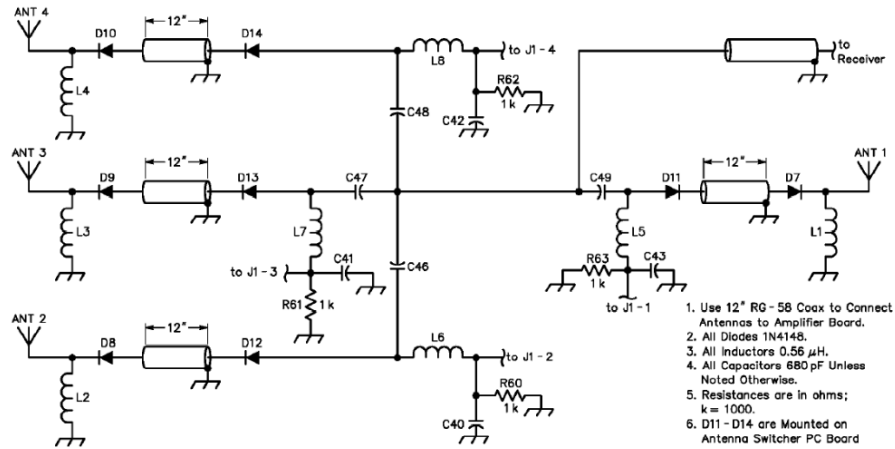

Fig. 3. Classic antenna switch for Pseudo-Doppler circuit [9]

with maximum switching frequency of 10 MHz, which significantly exceeds the attainable switching frequency for classic antenna switch.

The use of HMC253 circuit also significantly simplified the antenna switch circuitry. On the other hand, the disadvantage is that HMC253 circuit is presently available only with QFN socket, which is harder to mount on the PCB. The circuitry design is based on the HMC253 data sheet [5] and it is shown in Fig. 4. The HMC253 integrated circuit is placed in the center of the antenna array. The signal from individual antennas is sent to HMC253 integrated circuit through a coupling capacitor, each antenna is also loaded by a resistor.

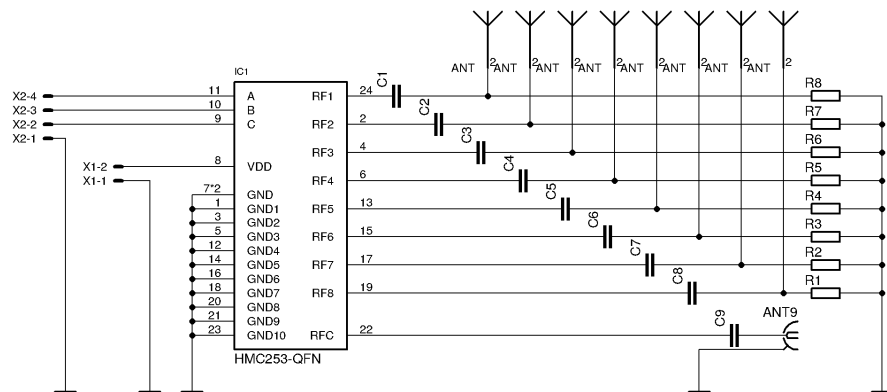

Fig. 4. New design antenna switch for Pseudo-Doppler circuit

Insertion loss is less than 1.7 dB in the entire bandwidth. The communication is done by a simple parallel interface consisting of three binary input pins which select the connected antenna based on the address derived from their logical values – each binary combination connects one of the eight inputs to the output [5].

On one hand, one of the greatest advantage of HMC253 integrated circuit is higher antenna switching frequency. On the other hand, the antenna switching in this case is discrete switching. However, to ensure the correct function of Pseudo-Doppler antenna, the switching should be smooth and the transition gradual, which means that the influence of an antenna should decrease and at the same time the influence of the following antenna should increase. In the classic antenna switch, this effect is attained by charging and discharging of the capacitors, which ensure that the antennas are turned on and off smoothly. This is not possible with the selected HMC253 integrated circuit, and the effect has to be achieved by high-frequency antenna switching, which imposes higher requirements on the further signal processing.

### 3 Signal Processing Using GNU radio

Signal processing is based on the well known open source project GNU Radio [7]. This software development toolkit provides a signal processing runtime and processing modules with convenient tools for creating software radio implementations. As a software defined radio receiver we used the HackRF One from Great Scott Gadgets company [6] which is a very powerful and affordable open source hardware platform.

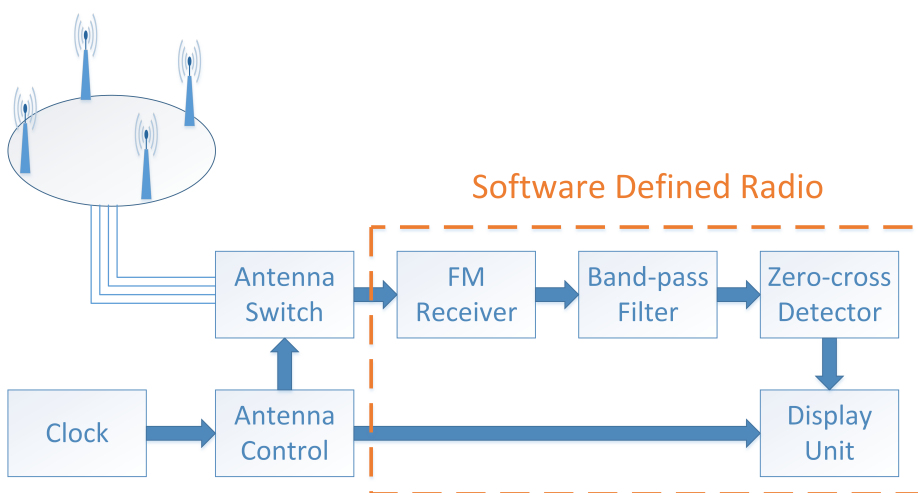

**Fig. 5.** Pseudo-Doppler block diagram with SDR

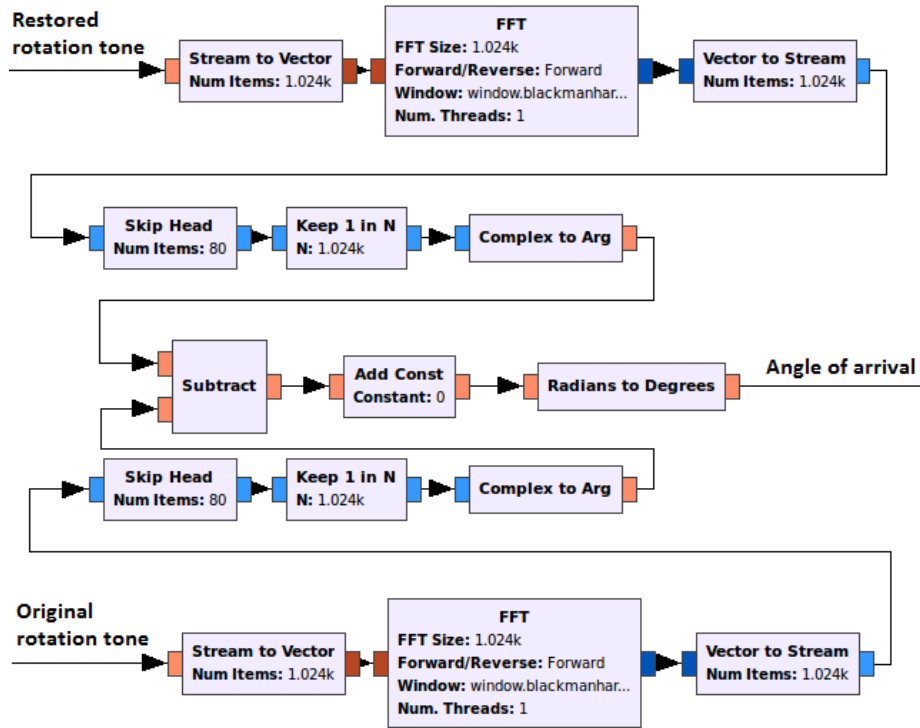

Fig. 6. GNU Radio flow diagram

Part of the Pseudo-Doppler direction finding system which is implemented in the software is enclosed by an orange box in Fig. 5. To achieve a good synchronization between the data stream and the antenna rotation, the internal clock of the HackRF One is used. Other tasks like tuner settings, FM demodulation or band-pass filtering are implemented in a very simple way with the help of the GNU Radio modules. On the other hand, comparison of a phase offset is a much harder task.

The filtered signal cannot be compared directly because of the different power levels, interferences etc. The Fig. 6 depicts processing of both rotation tones and angle of arrival calculation. The output data stream must be converted from the time domain to the frequency domain. This is done by Fast Fourier Transformation (FFT). Part of the data, whose size is equal to the size of the FFT window, is captured by the *Stream to Vector* module and processed by the *FFT* module and converted back to a data stream by the *Vector to Stream* module. The data are in the frequency domain now and the data relevant to the rotation tone can be now separated. This is done by the *Skip Head* and



Keep 1 in  $N$  modules. The Eq. (1) is used to determine the number of the data samples to be skipped.

$$N = \frac{f_s f_r}{N_{FFT}}, \quad (1)$$

where:

$N$	Number of elements to skip
$f_s$	Sample rate
$f_r$	Rotation tone frequency
$N_{FFT}$	Size of FFT

Since all digital samples of the signal are represented as complex numbers, the phase of the rotation tone is determined by their argument. The argument is obtained by the *Complex to Arg* module for each of the rotation tones. The phase offset, which is equal to the angle of arrival, is obtained after subtracting tones from each other.

Purpose of the *Add const* module is to calibrate angle of arrival with respect to the north. This calibration is needed after each start of the system. Automatic calibration with usage of the HackRF One is a subject of a future work.

## 4 Test in Real-Life Conditions

The final testing of the designed radio direction finding system was carried out in the open area with minimum of the obstacles. The AoA was measured from distance of 100 meters in 10 degrees increments. The result of this measurement is depicted in the Fig. 7. The Figure shows the expected AoA in degrees on x axis and the deviation between expected and measured AoA on y axis. As we can see, deviation angle of the system is less than 20 degrees. The reasons for that low accuracy could be the ground slope of the area used for testing. The elevation level varied during the test and could be source of the low accuracy.

An interesting topic for future research will be the influence of the transmitter distance on Pseudo-Doppler antenna and the used antenna switching model. The use of specialized switching circuit instead of classic passive components brought both advantages and disadvantages. The influence of the new switching circuitry on measurement precision has yet to be addressed.

We have tried to minimize the influence of the obstacles and the terrain profile on the measurements. The obstacles generally lead to reflections and the reflected signal negatively influences the measurement. Reflections generated step changes in measured values (angles), which complicates the use of Pseudo-Doppler antenna system inside in a closed environment or in a rugged area with many buildings. This was only the first test in real conditions and the development of the system continues.

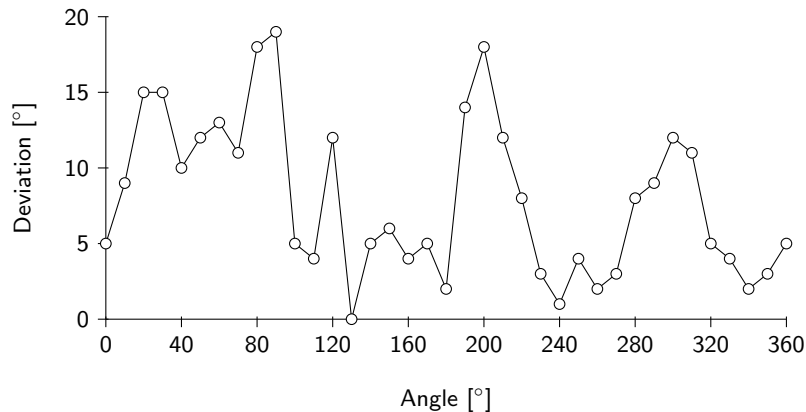

Fig. 7. AoA deviation

## 5 Conclusion

The software defined radio brought new possibilities to many sectors and the implementation of the radio direction finding system is not an exception. The prototype of the Pseudo-Doppler direction finding system based on the software defined radio was presented in this article. The proposed Doppler antenna array was designed, constructed and tested. The original hardware based design of the Doppler system was reimplemented in the software. The paper has focused on the most complex parts of the proposed implementation.

The main advantage of the designed system is the possibility to analyse the entire bandwidth, which the software defined radio can provide at once. The number of the parallelly analysed signals is limited only by the performance of the used computer. This is an enormous improvement against the traditional hardware implementation, where a separate receiver is needed for each individual signal.

## References

1. RDF Products. "Basics of the Watson-Watt Radio Direction Finding Technique" White Paper WN-004, Rev. B-01, 2007
2. H.A. Whale. "A Rotating Interferometer for the Measurement of the Directions of Arrival of Short Radio Waves" Proc. Phys. Soc. B 67 553, 1954
3. C.W. Earp and R.M. Godfrey. "Radio direction-finding by the cyclical differential measurement of phase" Journal of the Institution of Electrical Engineers - Part IIIA: Radiocommunication, Volume 94, Issue 15, 1947, p. 705 - 721
4. Peavey, David, and T. Ogumfunmi. "The single channel interferometer using a pseudo-doppler direction finding system." Acoustics, Speech, and Signal Processing, 1997. ICASSP-97., 1997 IEEE International Conference on. Vol. 5. IEEE, 1997.
5. Analog Devices, Inc. "GaAs MMIC SP8T Non-reflective switch, DC - 3.5 GHz" HMC253LC4 Datasheet v02.0414

6. Great Scott Gadgets, "HackRF One" 2015. [Online]. Available: <http://greatscottgadgets.com/hackrf/> [Accessed Aug. 3, 2015].
7. GNU Radio, "The Free and Open Software Radio Ecosystem" 2015. [Online]. Available: <http://gnuradio.org/redmine/> [Accessed Aug. 3, 2015].
8. Adcock, Frank. "Improvement in means for determining the direction of a distant source of electromagnetic radiation." British patent 130490, 1919.
9. M. Kossor, "A Doppler Radio - Direction Finder Part 2," QST, pp. 37-40, June 1999.