



**HAL**  
open science

## Design and Simulation Analysis of Transplanter's Planting Mechanism

Fa Liu, Jianping Hu, Yingsa Huang, Xiuping Shao, Wenqin Ding

► **To cite this version:**

Fa Liu, Jianping Hu, Yingsa Huang, Xiuping Shao, Wenqin Ding. Design and Simulation Analysis of Transplanter's Planting Mechanism. 4th Conference on Computer and Computing Technologies in Agriculture (CCTA), Oct 2010, Nanchang, China. pp.456-463, 10.1007/978-3-642-18333-1\_53 . hal-01559601

**HAL Id: hal-01559601**

**<https://inria.hal.science/hal-01559601v1>**

Submitted on 10 Jul 2017

**HAL** is a multi-disciplinary open access archive for the deposit and dissemination of scientific research documents, whether they are published or not. The documents may come from teaching and research institutions in France or abroad, or from public or private research centers.

L'archive ouverte pluridisciplinaire **HAL**, est destinée au dépôt et à la diffusion de documents scientifiques de niveau recherche, publiés ou non, émanant des établissements d'enseignement et de recherche français ou étrangers, des laboratoires publics ou privés.



Distributed under a Creative Commons Attribution 4.0 International License

# Design and simulation analysis of Transplanter's planting mechanism

Fa Liu, Jianping Hu, Yingsa Huang, Xiuping Shao, Wenqin Ding

Key Laboratory of Modern Agricultural Equipment and Technology, Ministry of Education&Jiangsu Province, Jiangsu University, Zhenjiang 212013, China  
Email:liufa1020@126.com

**Abstract.** A new-style transplanter's planting mechanism was designed, which was composed of Planetary Gear, Planetary Carrier, Connecting rod, Groove cam and Planting arm. Built the kinematics model and determined the main parameters which influenced the Plant-arm's locus by analyzing of the Kinematic model. Created the 3D Model in PRO/E and imported it into the Kinematics simulation software ADAMS, analyzing Groove-cam's offset angle, Connecting-rod's length and its impact on the Plant-arm's kinematics locus. The effect laws of the structural parameters on the Plant-arm's locus were obtained through analyzing the Plant-arm's locus, which got by changing the groove cam's horizontal offset angle ranging from  $0^\circ$  to  $20^\circ$ , the sum of Connecting-rod's length ranging from 130mm to 150mm, and the subtract of Connecting-rod's length ranging from 15mm to 25mm. The analysis results are of theoretical significance to the dimension synthesis and optimization design.

**Key words:** Transplanter, planting mechanism, ADAMS, Groove cam, Plant-arm's kinematics locus

## 1 Introduction

Raise seedling and transplant can increase crop production in every unit area, and make upgrowth ahead of time, which can withstand gale, harmful rain, low temperature, and other nature disaster. Besides, it also saving seed. Seeds are usually

grown under the film by farmer in many place, because it is useful to improve the soil temperature, keep moisture and restrain weeds.

The nacelle-type and dibble-type transplanting mechanism are good mechanism for transplanting film, but they are not convenient and safe to directly drop seedling and they are easy to leave out seedling when the machine are operated and their work efficient are low when seedling are transplanted over the larger areas. Now a simple and credible type of transplanting mechanism was designed, which was easy and convient to be operated and adjusted. the efficiency of the machine was much more greatly improved. There was less seedling to leave out in work progress. The three dimension model of the transplanting mechanism was establish in pro/e software. The relationship between the planting arm's locus and structural parameters was analyzed by the mechanical simulation software ADAMS in this paper.

## 2 Kinematic analysis of the planting mechanism

### 2.1 Structure and working principle of planting mechanism

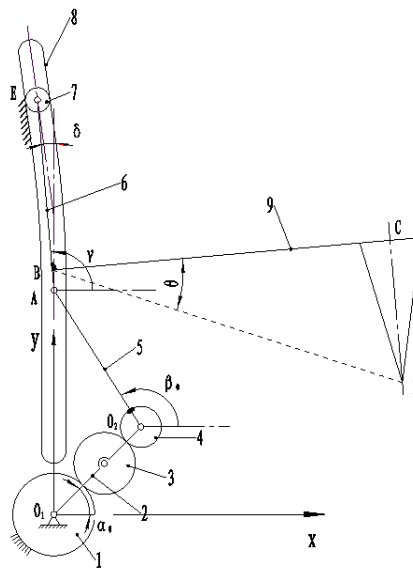

1. central gear    2.planetary carrier    3.planetary gear1    4. Planetary gear2  
 5.connecting rod1    6.connecting rod2    7.roller    8. Groove cam    9.planting arm

**Fig.1** planting mechanism structural chart

A transplanter's planting mechanism was shown in Figure 1, which was composed of planetary gear, planetary carrier, link, groove cam and planting arm. The numbers of sun-wheel's teeth was twice times that of the planetary gear's teeth. The cam groove was divided into two parts and a angle-off between the two part. Planting arm, fixed on the connecting rod 2, moved with the connecting rod 2.

## 2.2. Transplanter's planting mechanism kinematics equations

The initial position of planting bodies was shown in Figure 1. The Cartesian named  $xO_1y$  established as shown in fig.1. The Coordinate equation of the planetary gear's center  $O_2$  is:

$$\begin{cases} x_{O_2} = l_1 \cos(\alpha_0 + \omega t) \\ y_{O_2} = l_1 \sin(\alpha_0 + \omega t) \end{cases}$$

The Coordinate equation of the connecting rod's endpoint A is:

$$\begin{cases} x_A = x_{O_2} + l_2 \cos(\beta_0 + \omega t) \\ y_A = y_{O_2} + l_2 \sin(\beta_0 + \omega t) \end{cases}$$

The Coordinate equation of planting arm's endpoint B is:

$$\begin{cases} x_B = x_A + l_3 \cos \gamma \\ y_B = y_A + l_3 \sin \gamma \end{cases}$$

The Coordinate equation of planting arm's endpoint D is:

$$\begin{cases} x_D = x_B + \rho \cos(\theta + \frac{\pi}{2} - \gamma) \\ y_D = y_B - \rho \sin(\theta + \frac{\pi}{2} - \gamma) \end{cases}$$

The rate equation of the planetary gear's center  $O_2$  is:

$$\begin{cases} v_{x_{O_2}} = \omega l_1 \sin(\alpha_0 + \omega t) \\ v_{y_{O_2}} = \omega l_1 \cos(\alpha_0 + \omega t) \end{cases}$$

The endpoint A of the connecting rod 1 rate equation is:

$$\begin{cases} v_{x_A} = v_{x_{O_2}} + \omega l_2 \sin(\beta_0 + \omega t) \\ v_{y_A} = v_{x_{O_2}} + \omega l_2 \cos(\beta_0 + \omega t) \end{cases}$$

The rate equation of the planting arm's endpoint B is:

$$\begin{cases} v_{x_B} = v_{x_A} + \omega_2 l_3 \sin \gamma \\ v_{y_B} = v_{x_A} + \omega_2 l_3 \cos \gamma \end{cases}$$

The rate equation of the planting arm's endpoint D is:

$$\begin{cases} v_{x_D} = v_{x_B} - \omega_2 \rho \sin(\theta + \frac{\pi}{2} - \gamma) \\ v_{y_D} = v_{x_B} + \omega_2 \rho \cos(\theta + \frac{\pi}{2} - \gamma) \end{cases}$$

$$\omega_2 = \dot{\gamma}$$

$\alpha_0$  — the initial angle between the planetary carrier and the horizontal

$\beta_0$  — the initial angle between connecting rod 1 and the horizontal

$\gamma$  — the angle between connecting rod 2 and the horizontal

$\theta$  —  $\angle CBD$

$l_1$  — the length of the planet carrier

$l_2$  — the length of the connecting rod 1

$l_3$  — the length of the connecting rod 3

$\omega$  — the angular velocity of the planet carrier

### 3.Virtual Prototype Model of the Planting mechanism

The planting mechanism's three-dimensional model was established and assembled in the pro/e and then transmitted it into the mechanical simulation software Adams. The Planting mechanism's Virtual Prototype Model was established in the mechanical simulation software Adams as in Fig.2.

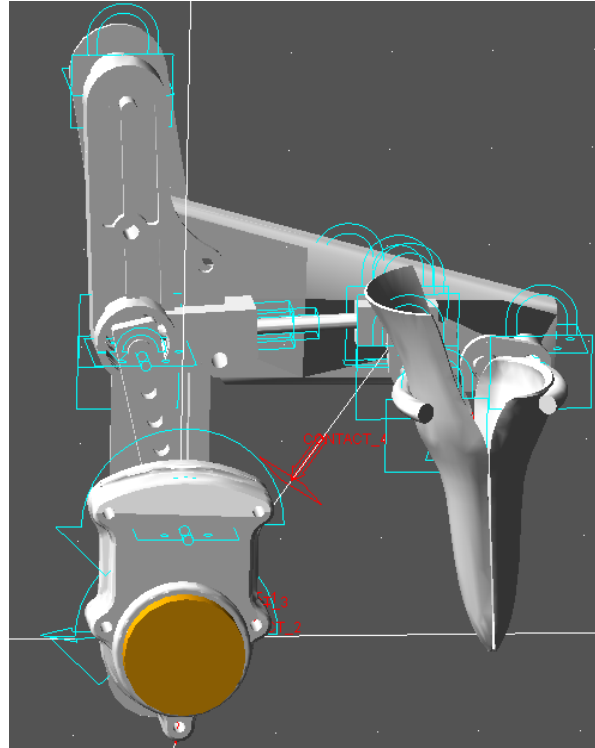

**Fig.2** The Planting mechanism' s Virtual Prototype Model

## **4.Kinematics simulation**

### **4.1.Planting mechanism's simulation in different structural parameters**

The shape of the planting arm's locus was the chief factor to effect the function of the transplanter. The groove cam's horizontal offset angle, the sum of Connecting-rod length and the subtract of Connecting-rod length were the main factors to effect the Plant-arm's locus by analyzing the transplanter's planting mechanism kinematics equations. So we built the Virtual Prototype Model of the Planting mechanism in the different structural parameters of the groove cam's horizontal offset angle, the sum of Connecting-rod length and the subtract of Connecting-rod length. The Planting arm's locus were got by the different Virtual Prototype Model's simulation as in Fig.3, Fig.4 and Fig.5. Structural parameter values in Table.1.

**Table.1** Structural parameter

	A (groove cam's horizontal offset angle)	B (sum of Connecting-rod length)	C (subtract of Connecting-rod length)
1	0°	0mm	120mm
2	5°	10mm	130mm
3	10°	20mm	140mm
4	15°	30mm	150mm
5	20°	40mm	160mm

Fig 3, Fig4 and Fig 5 is the planting arm's locus in different structural parameters respectively.

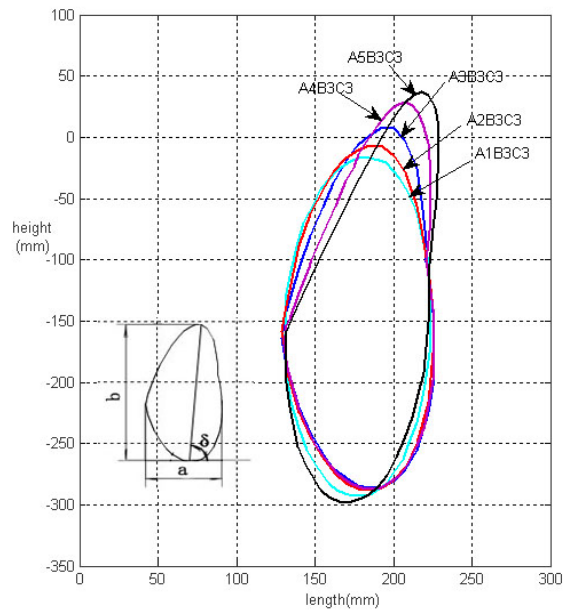

**Fig.3** Planting arm' s locus in different groove cam' s horizontal offset angle

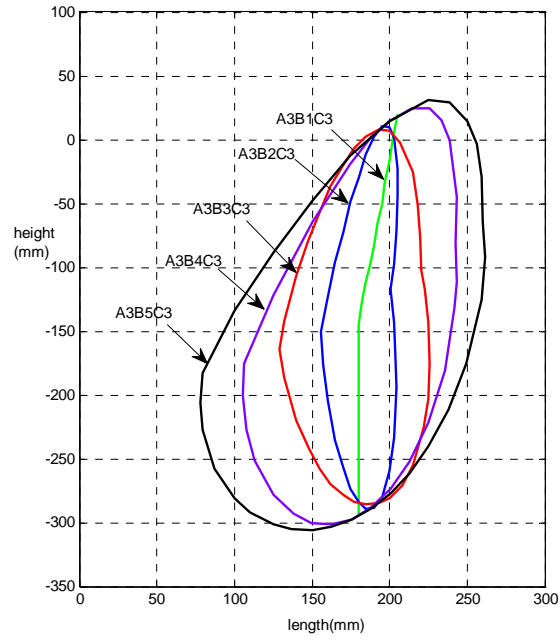

**Fig.4** Planting arm' s locus in different subtract of Connecting-rod length

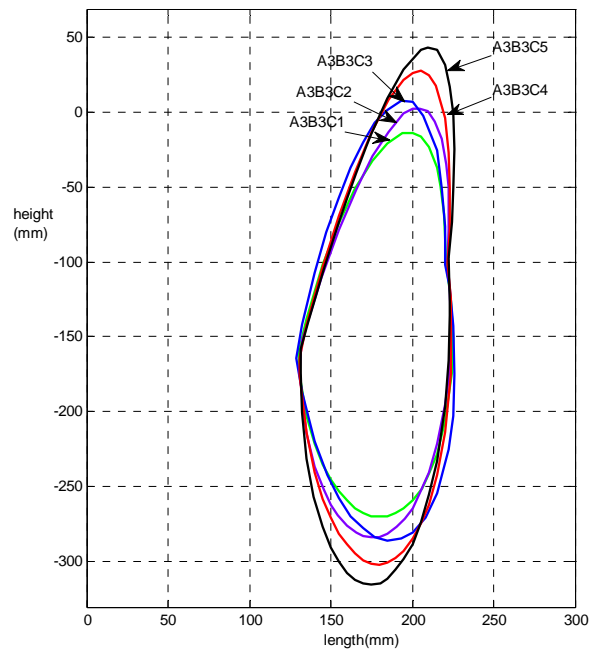

**Fig.5** Planting arm' s locus in different sum of Connecting-rod length



#### 4.2 The simulation results of planting mechanism were analyzed in different structural parameters

The shape of the planting arm's locus was determined by the width of planting arm's locus, the height and the deflection angle. So we selected the width of planting arm's locus, the height and the deflection angle as the evaluation criteria of planting arm's locus in this paper. The locus of the planting arm's was got by the simulation of the planting mechanism's virtual prototype model was in different structural parameters. Shown in Table.2.

a—the width of planting arm's locus. The planting distance was influenced by the value of a.

b—the height of planting arm's locus. The Planting Depth was influenced by the value of b.

c—the deflection angle of planting arm's locus, It was the angle between the horizontal and the line connecting the lowest point and the highest point of the locus. The stability of catching seedling were influenced by the value of c.

**Table.2** Simulation results analysis

Structural parameters	Results Fig.	Indicator value		
		Width(a)	Length(b)	Declination( $\delta$ )
A1B3C3	Fig. 3	93	276	0°
A2B3C3		97	281	0.6°
A3B3C3		97	292	3°
A4B3C3		96	315	4.4°
A5B3C3		98	335	7.9°
A3B1C3	Fig. 4	25	315	4.5°
A3B2C3		49	300	1.9°
A3B3C3		97	292	3°
A3B4C3		138	326	9°
A3B5C3		183	336	12°
A3B3C1	Fig. 5	94	256	4.5°
A3B3C2		93	286	5.8°
A3B3C3		97	292	3°
A3B3C4		93	330	4.4°
A3B3C5		94	360	5.6°

As is shown in Table 2, Fig.3 shows a set of curves of a width of about 97mm, a height ranging from 276mm to 335mm and a declination angle ranging from  $0^\circ$  to  $7.9^\circ$ . Fig.4 shows a set of curves of a width ranging from 25mm to 183mm, a height ranging from 292mm to 336mm and a declination angle ranging from  $1.9^\circ$  to  $16^\circ$ . Fig. 5 shows a set of curves of a width of about 94mm, a height ranging from 256mm to 360mm and a declination angle ranging from  $3^\circ$  to  $5.6^\circ$ .

## 5. Conclusion

- (1) The width of planting arm's locus depends on the subtract of Connecting-rod length. With the subtract of Connecting-rod length increasing, the width of planting arm's locus became wider and wider.
- (2) The height of planting arm's locus depends on the sum of Connecting-rod length, the subtract of Connecting-rod length and the groove cam's horizontal offset angle. With the sum of Connecting-rod length, the subtract of Connecting-rod length and the groove cam's horizontal offset angle increasing, the height of planting arm's locus became larger and larger.
- (3) The deflection angle of planting arm's locus depends on the groove cam's horizontal offset angle and the subtract of Connecting-rod length. With the groove cam's horizontal offset angle and the subtract of Connecting-rod length increasing, the deflection angle of planting arm's locus width of planting arm's locus became wider and wider.

## Acknowledgements

This work was financially supported by the three agricultural machinery project of Jiangsu Province for 2008.

## References

- [1] Wang Wenming, Dou Weiguo, Wang Chunguang. Parameter Analysis of the planting Process of 2ZT—2 Beet Transplanter[J]. Transactionsof the Chinese Society for Agricultural Machinery, 2009, 40 (1)

- [2] Li Qiyun, Wang Zunyuan. Main structure parameter and analysis on planting apparatus with twin conveyer belt[J]. Transactions of the Chinese Society for Agricultural Machinery, 1997, 28 (4):46~49.(in chinese)
- [3] Dong Feng, Geng Duanyang, Wang Zunyuan. study on block seedling transplanter with belt feeding mechanism[J]. Transactions of the Chinese Society for Agricultural Machinery, 2000, 31(2): 42~45. (in chinese)
- [4] Li Qiyun, Lu Shanwen, Li Lihua. Experimental study on a slideway parting-bowl-wheel transplanter[J]. Transactions of the Chinese Society for Agricultural Machinery 2001, 32(2): 30~33. (in chinese)
- [5] Feng Jun, Qin Gui, Song Weitang, et al. The kinematic analysis and design criteria of the dibble-type transplanter[J]. Transactions of the Chinese Society for Agricultural Machinery, 2002, 33(5): 48~50. (in chinese)
- [6] Zhou Deyi, Sun Yujing, Ma, Chenglin. Design and analysis of a supporting-seedling mechanism with cam and combined rocker[J]. Transactions of the Chinese Society for Agricultural Machinery, 2003, 34(5): 58~60. (in chinese)
- [7] Yu Gaohong, Zhao Fengqin, Wu Chuanyu, et al. Analysis of kinematic property of separating-planting mechanism with planetary gears[J]. Transactions of the Chinese Society for Agricultural Machinery, 2004, 35(6): 55~57. (in chinese)
- [8] Li Yaoming, Xu Lizhang, Chen Hang. Improved design of spade arm in 4YS-600 tree transplanter[J], Transactions of the CSAE, 2009, 25(3): 60- 63. (in chinese and English abstract)