



HAL
open science

The Staff Assignment Graph – Planning, Evaluating and Improving Personnel Deployment in Assembly Systems

Gert Zülch, Michael Leupold, Thilo Gamber

► To cite this version:

Gert Zülch, Michael Leupold, Thilo Gamber. The Staff Assignment Graph – Planning, Evaluating and Improving Personnel Deployment in Assembly Systems. International Conference on Advances in Production Management Systems (APMS), Sep 2011, Stavanger, Norway. pp.157-164, 10.1007/978-3-642-33980-6_19 . hal-01524228

HAL Id: hal-01524228

<https://inria.hal.science/hal-01524228v1>

Submitted on 17 May 2017

HAL is a multi-disciplinary open access archive for the deposit and dissemination of scientific research documents, whether they are published or not. The documents may come from teaching and research institutions in France or abroad, or from public or private research centers.

L'archive ouverte pluridisciplinaire **HAL**, est destinée au dépôt et à la diffusion de documents scientifiques de niveau recherche, publiés ou non, émanant des établissements d'enseignement et de recherche français ou étrangers, des laboratoires publics ou privés.



Distributed under a Creative Commons Attribution 4.0 International License

The Staff Assignment Graph

- Planning, Evaluating and Improving Personnel Deployment in Assembly Systems -

Gert Zülch, Michael Leupold, Thilo Gamber

ifab-Institute of Human and Industrial Engineering, Karlsruhe Institute of Technology
(formerly University of Karlsruhe), Karlsruhe, Germany
(gert.zuelch,michael.leupold,thilo.gamber)@kit.edu

Abstract. With regards to methods of assembly systems planning we are familiar with the depiction of the technical structure using capacity fields and graphs in addition to the modelling of assembly activities as a precedence diagram. However, no form of presentation has yet been defined that describes the assignment of staff within an assembly system. This paper discusses the concept of the staff assignment graph used to balance a hybrid assembly system, and in doing so marks a first attempt to close this gap and develop a more comprehensive planning method. The paper also explains how to evaluate staff assignment graphs and presents an algorithm for automatically generating them based on existing capacity graphs and taking a multi-criteria goal function into account.

Keywords: Assembly planning, Line balancing, Precedence diagram, Staff assignment graph

1 The challenges for assembly planning

Assembly systems are traditionally characterized by a high proportion of manual activity and correspondingly high labour costs. The prevailing competitive pressure results in the increased use of automation [1]. However, because complete automation is usually either impractical or intricate to implement for technical or economic reasons, hybrid assembly systems are often established consisting of both manual workstations and at least partially automated stations [2, 3].

This presents new challenges for the planning of such assembly systems due to the fact that an alternating sequence of manual and (partially) automated processes makes it difficult to balance them. According to Müller [4], the requirements of the assembly task as well as the employees and equipment involved in the assembly process must be looked at differentiated, paying particular attention to the distribution of personnel and machinery capacities.

2 Formal gap in the planning of assembly systems

Concerning the state of the art of assembly system balancing, the precedence diagram is still an important tool although it was introduced by Prenting and Battaglin as early as 1964 [5]. In this diagram, the individual assembly activities are depicted as nodes in a network that are linked both logically and timely (Fig. 1). In this presentation format, the time required for each activity is depicted as a supplementary attribute of each node.

In addition, Dittmayer introduced the capacity field in 1981, which helps divide up capacity in structured assembly systems that operate according to the division of labour [6, 7]. To this end, the cycle times per activity are recorded on the abscissa and the daily volume to be produced on the ordinate. Because the capacity required for an assembly task is generally greater than the capacity available at an individual assembly workstation, the required capacity must be broken down into individual subsections in such a way that each of the sections can be covered by the available capacity of a single workstation. Horizontally partitioning the required capacity divides it by volume, while vertical division is by type.

In 1995, Braun proposed the so-called complex diagram in order to support the planning of model mix assembly systems. This diagram combines the different precedence diagrams for each of the product variants in order to give an overall representation of all of the activities to be carried out in an assembly system [8, pp. 56].

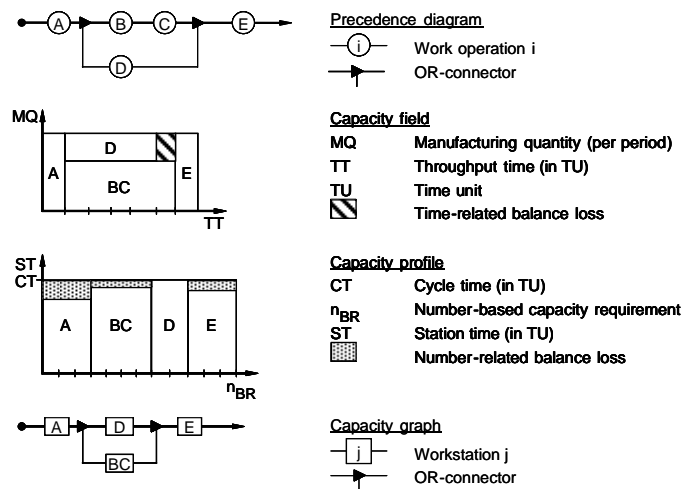

Fig. 1. Methods for assembly systems planning

Braun then refined the idea of the capacity field to develop the capacity graph [8, pp. 69]. This gives an equivalent diagrammatic representation of the capacity field. The areas of the capacity field are incorporated into the capacity graph as nodes, with arcs always inserted at the points where the respective areas within the capacity field touch along their vertical partitioning lines. Taking the cycle time per unit into

account, the capacity profile can be used in conjunction with the complex diagram to balance the model mix assembly system.

The planning of hybrid assembly systems throws up further challenges due to the fact that the capacity required by the activities in terms of workers, equipment and the work object differs. Nevertheless, traditional concepts for planning hybrid assembly systems often only take the perspective of one of these process elements, typically that of the bottleneck resource [9]. Müller goes one step further and develops a multi-stage precedence diagram concept that allows differentiation between assembly activities from the perspective of the workers, equipment and the work object. He is also the first to propose a staff assignment model for assembly systems in which groups of workers are assigned to several workstations within the assembly system in order to iron out differences in utilisation.

3 The staff assignment graph

However, no satisfactory solution has yet been found for the problem of distributing capacity within hybrid assembly systems with regards to the equal utilisation of both equipment and staff. A suitable method of representation and planning should above all take into account the assignment of staff in a model mix assembly line, for example multi-station assignments, group work and the use of stand-in workers. The idea of the staff assignment graph aims to close this gap in assembly planning. One first example of this can already be found in the above diagram following Müller [4, p. 101]. In the simple example given in Figure 2, an individual workstation is followed by an assembly step that is operated by two workers in a group.

Figure 3 shows a staff assignment graph using the example of a structured hybrid assembly system. The staff assignment graph is based on the capacity graph and its assignment of assembly activities from the precedence diagram to assembly workplaces. One node on the capacity graph is considered to be one assembly workplace. Parallel paths through the diagram represent parallel workplaces, each of which belongs to one workstation.

Similarly to Müller [4, pp. 99], workers can be assigned to multiple assembly workstations as a work group. This assumes that any such work group consists of workers with the same level of qualification who are therefore able to perform all assembly activities required. The number of workers within a work group is recorded in its upper left corner in the staff assignment graph.

In the case of multiple workstation operation, it can be assumed that the time required by the worker to cover the distance between the individual workstations accounts for a not-unsubstantial fraction of his/her total available capacity. For this reason, these times should also be recorded when planning the assembly system. This is done here by introducing a new kind of directed arc, the pathway arc, which defines the start, the end and the direction of movement. To store the time needed, the arc can either be annotated, or all of the time values can be recorded separately in a travel time matrix in order to avoid making the staff assignment graph unnecessarily complicated. In this matrix, the assembly stations make up the rows and columns. An

individual value within the matrix represents the time required by the worker to move from the assembly station given by the row to the one given by the column.

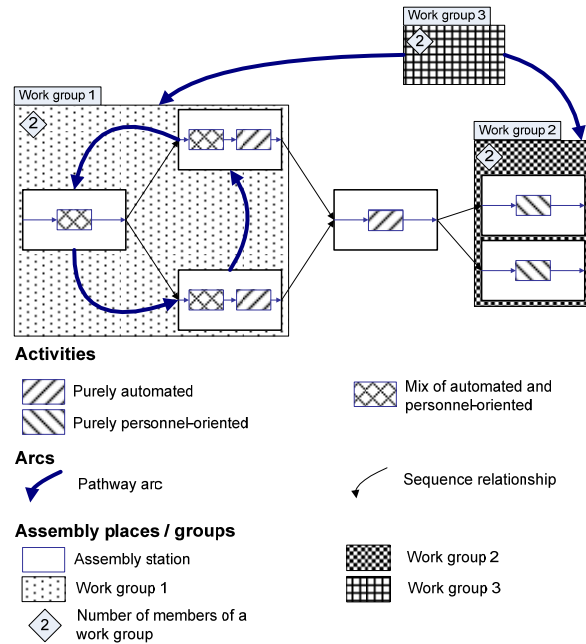

Fig. 2. Concept for a staff assignment graph using the example of a hybrid assembly line

Semi-autonomous work groups can be modelled using the work group concept already described for the staff assignment graph. Pathway arcs between the assembly stations assigned to the work group are not used. This indicates that the decision regarding the processing sequence is made by the semi-autonomous work group themselves, e.g. work group 2 in Figure 2.

The operation of multiple workstations by one or more workers can be indicated by first grouping the individual workstations within a local work group. The worker is then assigned to this group as one single group member. Optimised pathways between the individual assembly stations can be depicted using path arcs. One example for multiple machine operation is work group 1 in Figure 2.

One or more stand-in workers can be indicated by assigning them to a separate stand-in group which is annotated with the number of stand-in workers it contains and then linked to the workstations or assembly subsections it supports using pathway arcs. One example for the representation of a stand-in worker is work group 3 in Figure 2.

4 Evaluating staff assignment graphs

Both static, graph-theoretical key figures and dynamic key figures derived from simulation can be used to evaluate staff assignment graphs in terms of their implications on the assembly system. Our previous contribution [13] focused on the static evaluation taking the ratio of the number of work groups to the number of assembly workstations and the cluster coefficient of the staff assignment graph into account.

In order to dynamically evaluate a staff assignment graph a personnel-based simulation procedure can be used to analyse their dynamic impact on production logistics performance indicators. To this end, the OSim [12] simulation tool developed by the ifab-Institute has been expanded in order to support the depiction and simulation of staff assignment graphs. This also includes the ability to input a travel time matrix and model pathway arcs in order to depict the pathways covered by workers operating more than one workstation.

Using these new features it is possible to simulate and evaluate the effects of various staff assignment graphs in combination with existing precedence diagrams and capacity graphs. Relevant key figures which are output by the simulation tool typically include goal achievement degrees for lead times, resource utilization and process costs [13]. Additionally the key figure travel time for recording the time spent on the workers' movement in the assembly system was introduced.

5 Deriving staff assignment graphs

In a next step, a basic algorithm for deriving a good staff assignment graph for an existing capacity graph according to a multi-criteria goal function was designed and implemented. One of the problems for such an algorithm is that out of the huge number of staff assignment graphs only a small fraction is valid. This is due to the fact that automatically generated staff assignment graphs may be acyclic or that assembly stations are kept idle for too long so that buffers overflow.

Thus, the algorithm is divided into two steps. The first step determines all valid staff assignment graphs while the second and compares those graphs using simulation and evaluates them with the pre-defined set of criteria.

5.1 The backtracking algorithm

The design of the algorithm follows the backtracking technique. Backtracking is a meta-algorithm for algorithmically enumerating all possible solutions to a problem [14, p. 105]. Using a depth-first search a tree of partial solutions to the problem – each represented by a node of the rooted backtracking tree – is built. Possible continuations of a partial parent solution are represented by the node's children. If the evaluation of a partial solution leads to the conclusion that no feasible solution can be derived from it, its node is rejected and the search is continued with the next node. The tree's leaves represent final solutions to the whole problem. If the search reaches a leaf, the algorithm could either stop if only a single feasible solution is searched, or track back to

the leaf's parent node to search and enumerate more solutions [14, p. 106 ff.]. Figure 4 depicts the order in which the tree of solutions is built during the search process. Partial solutions without a feasible continuation and final solutions are marked accordingly.

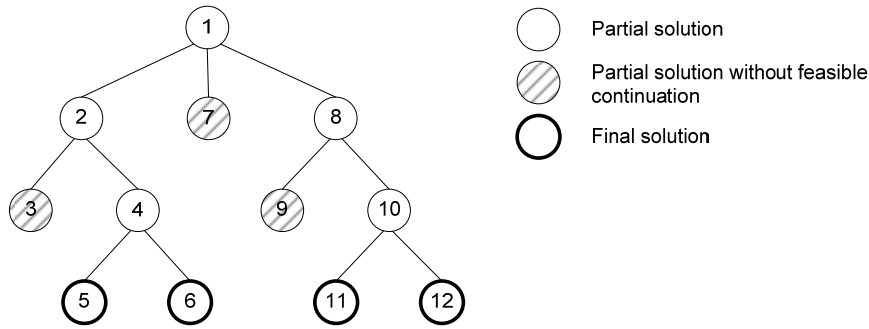

Fig. 3. Tree representation of the backtracking algorithm

5.2 Backtracking for deriving staff assignment graphs

The implementation of the backtracking algorithm for deriving staff assignment graphs constructs sequences of staff movements similar to how a discrete event simulation procedure works. One possible "simulation run" is represented by a path in the tree starting from the root node and ending at a leaf node. Each node of the tree marks an intermediate point in time. Each child node depicts a possible continuation of the simulation run which is created by adding one or more pathway arcs to the staff assignment graph.

Building and searching the tree is handled by the function `nextEvent` which operates in several steps:

1. Handle current events like the arrival of an assembly order, the end of a worker's movement or the completion of an assembly activity as part of the order.
2. Check if the current node represents a feasible partial solution to the problem, if it is not, mark the node unfeasible and track back to the parent node.
3. If the node is a possible final solution, evaluate it with the defined criteria (see 5.3).
4. Determine possible continuations by adding a child node for each combination of pathway arcs that could be added to the staff assignment graph. When adding a pathway arc, start the corresponding assembly worker's movement.

Input parameters to the algorithm are the assembly system to be planned, the available number of assembly workers as well as the cycle length. A multi-criteria goal function in order to evaluate and compare feasible solutions is also a needed input of the algorithm.

5.3 Multi-criteria evaluation

When a feasible final solution is found by the backtracking algorithm (see 5.2), it is evaluated using the simulation procedure described earlier (see 4). All performance indicators supported by the simulation procedure can be used as goal criteria. These performance indicators are computed as results of the simulation run and are stored for each of the feasible solutions. After all alternative solutions have been evaluated a lexicographic, an additive or a maximin preference order [15, pp. 184 ff.] is used to combine the goal criteria and to determine the optimal solution.

5.4 Pilot study

In order to verify the algorithm and to check its runtime behaviour a pilot study was conducted using a synthetic assembly line with seven assembly activities. The assembly line initially consisted of five assembly stations arranged in U-shape and was operated by five assembly workers. Due to the automation of two of the assembly activities, utilisation at two of the stations dropped below 30 %. Thus it was assumed that four assembly workers could suffice for operating the line.

The backtracking algorithm found the apparent optimal solution in which one of the workers operated both of the assembly workstations containing automated activities. During the backtracking procedure, 18,960 nodes of the solution tree were handled and 648 solutions in leaf nodes were found. Runtime was 19 s on a desktop PC, 14.5 s of which was spent on the multi-criteria evaluation of the feasible solutions.

The conclusion is that while the optimal solution was found by the algorithm - verifying that it works - the runtime behaviour might not yet be suitable for more complex problems. Therefore, further investigations and improvements will have to be carried out.

6 Targeted planning of assembly systems

Braun [8, pp. 129] was able to quantify relationships between the precedence resp. complex diagrams and the capacity graphs. Regression equations could be derived for certain influential parameters with regards to selected target values. This made it possible to create meaningful capacity graphs using the parameters for the precedence or the complex diagram.

Expectations are that it will also be possible to derive quantifiable relationships between the planning parameters for staff assignment and individual target criteria using the structural parameters of the capacity graph and staff assignment graph. It is also necessary to verify whether staff assignment graphs with different parameters show different results even when their corresponding precedence diagram and capacity graph are the same. To this end, factorial experiments should be used to determine the influence of each parameter on the target criteria. The interaction of parameters identified as being significant should then be investigated using statistical design of experiments.

7 Conclusions and further research

This paper presents the concept of the staff assignment graph and an algorithm which can be used to derive a staff assignment graph for an existing capacity graph. Further research should evaluate the algorithm using examples from literature and practice. Moreover, the algorithm should be improved regarding runtime behaviour.

To draw conclusions suitable for practitioners, it will be necessary to perform studies using examples from existing work systems in order to verify the usefulness of the algorithm for its use in industry. Also, further investigations should try to compare staff assignment graphs and the corresponding capacity graphs. Based on an appropriate design of experiments, influential factors should be determined and if possible, rules should be derived describing which kinds of staff assignment graphs best suit various forms of capacity graphs.

References

1. Lotter, B.: Sicherung der Montage am Standort Deutschland. In: Lotter, B., Enderle, W., Roszkopf, M., Olbrich, W., David, V., Oldenburg, S. (eds.) HYMOS - Hybride Montagesysteme, Schlussbericht zum BMBF-Verbundprojekt, pp. 11-18. Verlag der Gesellschaft für Arbeitsschutz- und Humanisierungsforschung, Dortmund (1999).
2. Seliger, G., Neu, S.: Montagesysteme. In: Eversheim, W., Schuh, G. (eds.) Produktion und Management "Betriebshütte", Teil 2, pp. 10-35. Springer-Verlag, Berlin, Heidelberg, New-York (1996).
3. Spath, D., Baumeister, M.: Synchronisation of material flow and assembly in hybrid and modular systems. *Assembly Automation*, vol. 21, pp. 152-157. Emerald, Bingley, UK (2001).
4. Müller, R.: Planung hybrider Montagesysteme auf Basis mehrschichtiger Vorranggraphen. Shaker, Aachen (2002).
5. Prenting, T., Battaglin, R.M.: The Precedence Diagram: A Tool for Analysis in Assembly Line Balancing. *Journal of Industrial Engineering*. 15, pp. 209-213 (1964).
6. Dittmayer, S.: Arbeits- und Kapazitätsteilung in der Montage. Springer, Berlin, Heidelberg (1981).
7. Warnecke, H.-J., Dittmayer, S.: Planning of Division of Labor in the Assembly Environment. *CIRP Annals - Manufacturing Technology*. 30, pp. 395-400. Elsevier, Oxford (1981).
8. Braun, W.J.: Beitrag zur Festlegung der Arbeitsteilung in manuellen Montagesystemen. Universität Karlsruhe, Karlsruhe (1995).
9. Müller, R., Schneck, M.: Dynamische Bewertung von Planungen für hybride Montagesysteme. In: Heel, J., Krüger, J. (eds.) Personalorientierte Simulation - Praxis und Entwicklungspotential, pp. 73-88. Shaker, Aachen (1999).
10. Watts, D.J., Strogatz, S.H.: Collective dynamics of "small-world" networks. *Nature*, 393, pp. 440-442 (1998).
11. Lewis, T.G.: *Network Science: Theory and Applications*. John Wiley and Sons, Hoboken, NJ (2009).
12. Jonsson, U.: Ein integriertes Objektmodell zur durchlaufplanorientierten Simulation von Produktionssystemen. Shaker, Aachen (2000).

13. Zülch, G., Leupold, M., Gamber, T.: The Staff Assignment Graph – A New Approach to Assembly Systems Planning. In: Frick, J. (ed.) *Advances in Production Management Systems, Value Networks: Innovation, Technologies and Management*. APMS, Stavanger (2011).
14. Kreher, D.L., Stinson, D.: *Combinatorial Algorithms*. CRC, London (1999).
15. Körth, H.: Zur Berücksichtigung mehrerer Zielfunktionen bei der Optimierung von Produktionsplänen. *Mathematik und Wirtschaft*, pp. 184-201. Verl. d. Wirtschaft, Berlin (1969).
16. Zülch, G., Fischer, J.: An Integrated Object Model as a World of Model Components for an Activity Network Based Simulation Approach. In: Verbraeck, A., Krug, W. (eds.) *Simulation in Industry*, pp. 74-79. SCS-Europe, Delft, Erlangen, San Diego (2002).