



HAL
open science

Improving Current and Voltage Transformers Accuracy Using Artificial Neural Network

Haidar Samet, Farshid Nasrfard Jahromi, Arash Dehghani, Afsaneh Narimani

► **To cite this version:**

Haidar Samet, Farshid Nasrfard Jahromi, Arash Dehghani, Afsaneh Narimani. Improving Current and Voltage Transformers Accuracy Using Artificial Neural Network. 8th International Conference on Artificial Intelligence Applications and Innovations (AIAI), Sep 2012, Halkidiki, Greece. pp.435-442, 10.1007/978-3-642-33409-2_45 . hal-01521404

HAL Id: hal-01521404

<https://inria.hal.science/hal-01521404v1>

Submitted on 11 May 2017

HAL is a multi-disciplinary open access archive for the deposit and dissemination of scientific research documents, whether they are published or not. The documents may come from teaching and research institutions in France or abroad, or from public or private research centers.

L'archive ouverte pluridisciplinaire **HAL**, est destinée au dépôt et à la diffusion de documents scientifiques de niveau recherche, publiés ou non, émanant des établissements d'enseignement et de recherche français ou étrangers, des laboratoires publics ou privés.



Distributed under a Creative Commons Attribution 4.0 International License

Improving Current and Voltage Transformers Accuracy Using Artificial Neural Network

Haidar Samet*, Farshid Nasrfard Jahromi*, Arash Dehghani*
Afsaneh Narimani**

*Shiraz University

**Foolad Technic International Engineering Company

samet@shirazu.ac.ir, farshid.nasr2010@yahoo.com, dehghani_arash@yahoo.com,
afsaneh_narimani@yahoo.com

Abstract. Capacitive Voltage Transformers (CVTs) and Current Transformers (CTs) are commonly used in high voltage (HV) and extra high voltage (EHV) systems to provide signals for protecting and measuring devices. Transient response of CTs and CVTs could lead to relay mal-operation. To avoid these phenomena, this paper proposes an artificial neural network (ANN) method to correct CTs and CVTs secondary waveform distortions caused by the transients. PSCAD/EMTDC software is employed to produce the required voltage and current signals which are used for the training process and finally the results show that the proposed method is accurate and reliable in estimation of the CT primary current and the CVT primary voltage.

Keywords: Artificial Neural Network (ANN), Capacitive Voltage Transformers (CVTs), Current Transformers (CTs), Transient.

1 Introduction

The operation of the protection relays is dependent on the measured signals such as current and voltage signals which are measured by CTs and CVTs. Thus an error in these signal measurements could lead to mal-operation or substantial delay in tripping of the protection relays. The CT and CVT output signals may not follow their input signals due to the transients mainly caused by current transformers saturation and discharging of the capacitive voltage transformers internal energy during faults.

Several techniques on the compensation of the distorted secondary current and voltage signals have been published. An algorithm to estimate the magnetizing current at each time step by using the magnetization curve of a CT was reported in [1], the other algorithm detects the saturation using the Discrete Wavelet Transform (DWT) and compensates the distorted section of a secondary current with features extracted from the healthy section using a least mean square fitting method [2].

Another method is to Compensate the error of CT by using hysteresis and Eddy characteristic [3]. Some digital methods to correct the secondary waveforms of the CT are proposed in Ref.[4]. One method is to detect high Source Impedance Ratio (SIR) conditions that could lead to severe CVT transients and add a time delay to the tripping decision of distance relay [5].

The method discussed in Ref. [6] proposes the use of artificial neural networks (ANNs) to correct CVT secondary voltage distortions due to CVT transient. Another method is to compensate the distorted secondary waveforms of the CVT in the time domain by considering the hysteresis characteristics of the core [7]. The method introduced in Ref. [8] proposes the use of compensation algorithms based on of the CVT transfer function. Some least squares phasor estimation techniques for estimation of voltage and current phasors are presented in Refs. [9] and [10].

This paper begins with analysis of the contributing factors in CT and CVT transients. The details of the simulated power system to produce the different cases which are used in the training and testing process are presented in the later section. An ANN method for CT and CVT error compensation is presented in section 5. Results clearly show that the proposed method could estimate the primary signals accurately.

2 CT Transients

CT model used in simulations is shown in Figure1 [11]. Real iron-cored CTs are not ideal and since the reluctance of the core is not infinite, the current which is obtained by dividing the primary current (I_p) to the turns ratio (N), is different from the secondary current (I_s) in amplitude and phase due to existence of exciting current (I_e).

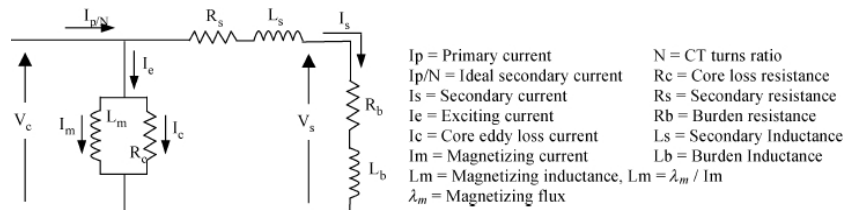

Fig. 1. Equivalent circuit of a CT [11]

3 CVT Transients

CVT model used in simulations is shown in Figure 2 [12]. C_1 and C_2 are stack capacitances. L , R , L_{T1} and R_{T1} are inductance and resistance, respectively, of the tuning reactor and the step down transformer. L_0 and R_0 are burden inductance and

resistance and f is a subscript for parameters of the anti-resonance circuit. The CVT Transients are basically controlled by the following factors:

A. Fault inception angle (point on wave)

The CVT output voltage does not follow the primary voltage for several cycles after the fault occurs. The timing of the faults on the voltage waveform (fault inception) affects the CVT transients. The transients of the faults occurring at voltage peaks and voltage zeros are the least severe and the most severe, respectively [3].

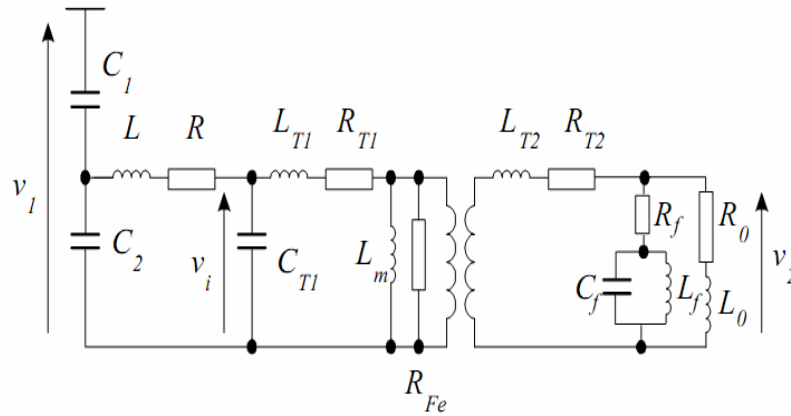

Fig. 2. Equivalent circuit of a CVT [12]

B. Coupling capacitors

The higher the sum of the capacitances ($C=C_1+C_2$), the lower the magnitude of the transients. High-C CVTs decrease the magnitude of the CVT transients but are more expensive. So there should be a balance between CVT performance and CVT cost [12].

C. Ferroresonance suppression circuit

There are two models of a ferroresonance suppression circuit which are shown in Figure 3. The transients of the CVT with the passive model are less severe so the output voltage is less distorted [12], [6].

D. CVT burden

The energy accumulated in the CVT storage elements could be dissipated in the CVT burden. Therefore, the different CVT burden could change the shape and duration of the CVT transients. As a rule, if the CVT is fully loaded, the transients would be less severe [12].

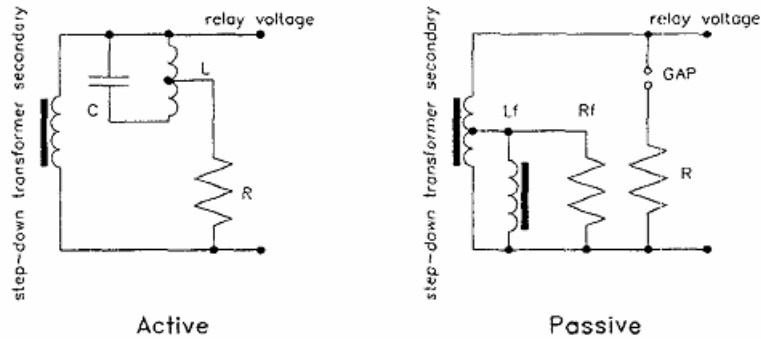

Fig. 3. Active and Passive Ferroresonance suppression circuit [3]

4 Power System Model

A three-phase 230 kV, radial power system is used in the simulations. The one-line diagram of this system is shown in Figure 4 and its parameters are shown in Table 1. Since ANN methods require an adequate amount of data for the training process, samples of the secondary voltage and current signals are achieved by using PSCAD/EMTDC software and then the primary voltage and current signals could be estimated by using the proposed method. The parameters of the CT and CVT are shown in tables 2 and 3, respectively.

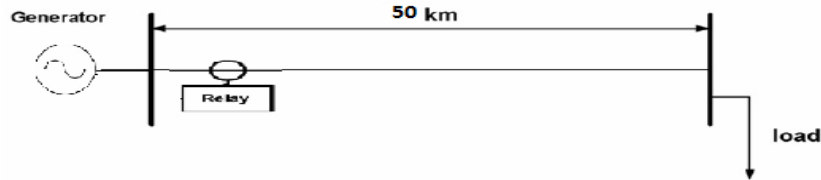

Fig. 4. Structure of the power system model

Table 1. Simulated power System parameters

Generator impedance(Ω)	1	
Line impedance(Ω/km)	$0.072 + j 0.416$	
Load	Active power(MW)	100
	Reactive power(MVAR)	2

Table 2. CT circuit parameters

Primary turns	20
Secondary turns	200
Secondary resistance	0.5 Ω
Secondary Inductance	0.8e3H
Area	2.601e-3m*m
Path length	0.6377m
Burden resistance	0.5 Ω

Table 3. CVT circuit parameters

Capacitor-1	2920 pF
Capacitor-2	134952 pF
Compensating inductance	42 H
VT ratio	43.48
Primary inductance	0.47e-3 H
Primary resistance	0.05 Ω
Secondary inductance	0.47e-3 H
Secondary inductance	0.18 Ω
Eddy current loss at normal conditions	2.5 W
Secondary operation voltage	115 V
Operating flux density	0.8 T
Hysteresis loss at normal conditions	5 W
Burden resistance	301 Ω
Burden inductance	2.4 H

5 Proposed Neural Network Compensating Method

5.1 Training patterns

To generate training patterns, the following conditions are changed from the base case: fault inception angle, fault type and fault resistance. The training pattern data generation is shown in Table 4.

Table 4. Training pattern data generation

Fault inception angle($^{\circ}$)	Different values between (0-360)with a step of 45 degrees
Fault type	Single-phase-to-ground, phase-to-phase-to-ground, three-phase -to- ground
Fault resistance(Ω)	0.01, 1, 100

5.2 Network Structure and Training

An ANN has the ability to learn from data. Such a situation is shown in Figure 5. Typically many of such input/output pairs are needed to train a network. A very important feature of these networks is their adaptive nature, where “learning by example” replace “programming” in solving problems. ANNs can be used to perform different tasks in power system relaying for signal processing and decision making [13]. A major problem with ANNs is that there is no exact rule to choose the number of hidden layers and neurons per hidden layer[14].The most widely used learning algorithm in an ANN is the Back-propagation algorithm [13],[14].

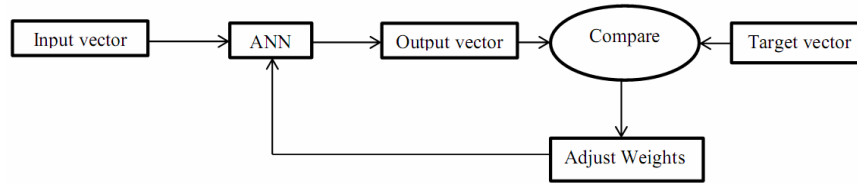

Fig. 5. A learning cycle in the ANN model

In this paper, for each CT and CVT a feedforward neural network with two hidden layers is used to process the training input data. The sampling rate is 40 samples per one 50-Hz cycle. The neural network includes 20 inputs, 20 outputs, two hidden layers (the first one with 4 neurons and the second one with 3 neurons). The inputs are the instantaneous values of the secondary current and voltage of the CT and CVT, respectively and the outputs are the instantaneous values of the primary sides of the CT and CVT, respectively. A log-sigmoid function as the activation function of the hidden layer neurons and a tan-sigmoid function for the output layer are used. The neural network is trained by Back-Propagation (BP) algorithms.

5.3 Test results

The accuracy of the proposed method is tested with patterns which are different from the training patterns. Figures 6 and 7 show the test results of the CT. Furthermore, Figures 8 and 9 show the test results of the CVT. The left side figures show the ideal (primary side), actual (secondary side) and the output of ANN while the right side figures show the estimation errors. The results show that the ANN output could exactly follow the ideal CT and CVT outputs ("ideal output" here means the primary

value of CT and CVT and the "actual output" means the secondary side value of CT and CVT).

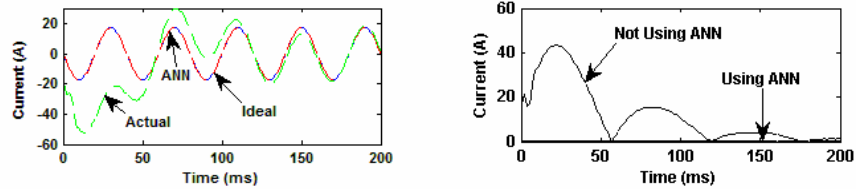

Fig. 6. a) CT waveforms for B-G fault with inception angle= 300° and fault resistance= 0.1Ω b) Estimation error

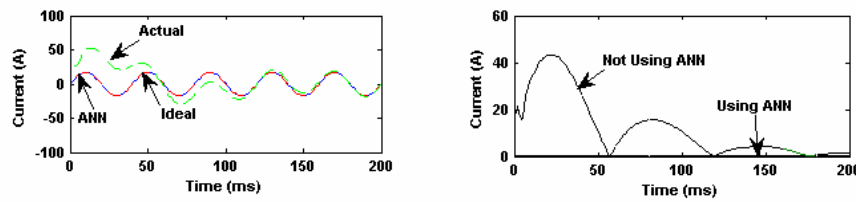

Fig. 7. a) CT waveforms for B-G fault with inception angle= 120° and fault resistance= 0.1Ω b) Estimation error

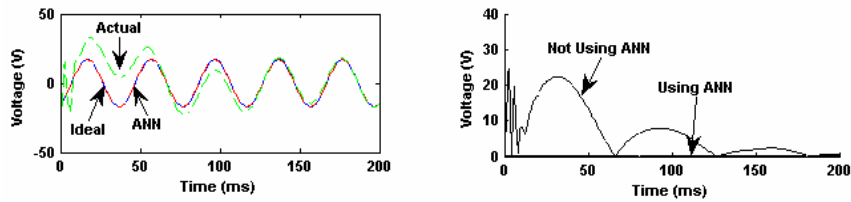

Fig. 8. a) CVT waveforms for A-B-G fault with inception angle= 60° and fault resistance= 0.1Ω b) Estimation error

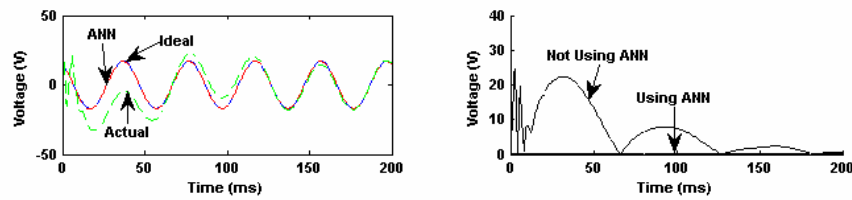

Fig. 9. a) CVT waveforms for A-B-C fault with inception angle= 240° and fault resistance= 0.1Ω b) Estimation error

6 Conclusion

The operation of the protection relays is dependent on the measured signals such as current and voltage signals which are measured by CTs and CVTs. The CT and CVT output signals may not follow their input signals due to their inherent transients. An ANN method for CT and CVT error compensation is presented in this paper which is an approximation of the inverse transfer function. Test results clearly show that the proposed method could estimate the primary signals accurately under different conditions.

References

1. Kang, Y.C., Kang, S.H., Jones, A.T., Aggarwal, R.K.: An algorithm for compensating secondary current of current transformers. *IEEE Trans. Power Delivery*, vol. 12, no. 1, 116--124 (1997)
2. Li, F.: combined wavelet transform and regression technique for secondary current compensation of current transformer. *IEEE Proc.-Gener. Transm.Distrib.* 149, 497--503 (2002)
3. Locci, N., Muscas, C.: hysteresis and eddy currents compensation in CT. *IEEE Trans. Power Delivery*, vol. 16, no. 2, 147, 154--159 (2001)
4. Locci, N., Muscas, C.: A Digital Compensation Method for Improving Current Transformer Accuracy. *IEEE Trans. Power Delivery*, vol. 15, no. 4, 1104--1109 (2000)
5. Hou, D., Roberts, J.: Capacitive Voltage Transformers: Transient Overreach Concerns and Solutions for Distance Relaying. in *Proc. Canadian Conference on Electrical and Computer Engineering*. 147, 26--29 (1996)
6. Kh. Zadeh, H., Li, Z.: A compensation scheme for CVT transient effects using artificial neural network. *ScienceDirect, Elsevier*, 30--38 (2006)
7. Kang, Y.-C., Zheng, T.-Y., Choi, S.-W., Kim, Y.-H. Kim, Y.-G., Jang, S.-I. Kang, S.-H.: Design and evaluation of a compensating algorithm for the secondary voltage of a coupling capacitor voltage transformer in the time domain. *IET Gener.Transm.Distrib.*, Vol. 3, no. 9, 793--800 (2009)
8. Izykowski, J., Kasztenny, B., Rosolowski, E., Saha, M.M., Hillstrom, H.: T.F. M.S Dynamic Compensation of Capacitive Voltage Transformers. *IEEE Trans. Power Delivery*, vol. 13, no. 1, 116--122 (1998)
9. Ajaei, F. B., Sanaye-Pasand, M.: Minimizing the Impact of Transients of Capacitive Voltage Transformers on Distance Relay. in *Proc. Indian Conference on Power System Technology*, 1--6 (2008)
10. Pajuelo, E., Ramakrishna, G, Sachdev, M.S. An Improved Voltage Phasor Estimation Technique to Minimize the Impact of CCVT Transients in Distance Protection. *IEEE Trans. Power Delivery,Canada*, 454--457 (2005)
11. Pan, J., Vu, K., Hu,Y.: An Efficient Compensation Algorithm for Current Transformer Saturation Effects. *IEEE Trans. Power Delivery*, vol. 19, no. 4, 1623--1628 (2004)
12. Kasztenny, B., Sharples, D., Asaro, V., Pozzuoli, M.: Digital Relays and Capacitive Voltage Transformers: Balancing Speed and Transient Overreach. *53rd Annual Conference for Protective Relay Engineers, College Station*, 1--22 (2000)
13. Jhr, G.K.: Artificial Neural Network. *Indian Agricultural Research Institute PUSA*, 1--10 (1981), [http:// www.iasri.res.in/ebook/EB_SMAR/ebook_pdf%20files/Manual%20IV/3-ANN.pdf](http://www.iasri.res.in/ebook/EB_SMAR/ebook_pdf%20files/Manual%20IV/3-ANN.pdf)
14. Saha, M.M., Rosolowski, E., Izykowski, J.: Artificial Intelligent Application to Power System Protection., 195--197, [http:// zas.ie.pwr.wroc.pl/er_india00_ai.pdf](http://zas.ie.pwr.wroc.pl/er_india00_ai.pdf)