



**HAL**  
open science

## **Factory Modelling: Combining Energy Modelling for Buildings and Production Systems**

Peter D. Ball, Melanie Despeisse, Steve Evans, Rick M. Greenough, Steve B. Hope, Ruth Kerrigan, Andrew Levers, Peter Lunt, Vincent Murray, Mike R. Oates, et al.

► **To cite this version:**

Peter D. Ball, Melanie Despeisse, Steve Evans, Rick M. Greenough, Steve B. Hope, et al.. Factory Modelling: Combining Energy Modelling for Buildings and Production Systems. 19th Advances in Production Management Systems (APMS), Sep 2012, Rhodes, Greece. pp.158-165, 10.1007/978-3-642-40352-1\_21 . hal-01472237

**HAL Id: hal-01472237**

**<https://inria.hal.science/hal-01472237v1>**

Submitted on 20 Feb 2017

**HAL** is a multi-disciplinary open access archive for the deposit and dissemination of scientific research documents, whether they are published or not. The documents may come from teaching and research institutions in France or abroad, or from public or private research centers.

L'archive ouverte pluridisciplinaire **HAL**, est destinée au dépôt et à la diffusion de documents scientifiques de niveau recherche, publiés ou non, émanant des établissements d'enseignement et de recherche français ou étrangers, des laboratoires publics ou privés.



Distributed under a Creative Commons Attribution 4.0 International License

# Factory modelling: combining energy modelling for buildings and production systems

P.D.Ball<sup>1</sup>, M.Despeisse<sup>1</sup>, S.Evans<sup>2</sup>, R.M.Greenough<sup>3</sup>, S.B.Hope<sup>4</sup>, R.Kerrigan<sup>5</sup>,  
A.Levers<sup>6</sup>, P.Lunt<sup>6</sup>, V.Murray<sup>5</sup>, M.R.Oates<sup>3</sup>, R.Quincey<sup>5</sup>, L.Shao<sup>3</sup>, T.Waltniel<sup>4</sup>, and  
A.J.Wright<sup>3</sup>

<sup>1</sup> Manufacturing and Materials Department, Cranfield University, UK

<sup>2</sup> Institute for Manufacturing, Cambridge University, UK

<sup>3</sup> Institute of Energy and Sustainable Development, De Montfort University, UK

<sup>4</sup> Toyota Motor Europe, Belgium

<sup>5</sup> Integrated Environmental Solutions Ltd, UK

<sup>6</sup> Airbus Operations Ltd, UK

p.d.ball@cranfield.ac.uk

**Abstract.** Traditionally, manufacturing facilities and building services are analysed separately to manufacturing operations. This is despite manufacturing operations using and discarding energy with the support of facilities. Therefore improvements in energy and other resource use to work towards sustainable manufacturing have been sub-optimal. This paper presents research in which buildings, facilities and manufacturing operations are viewed as inter-related systems. The objectives are to improve overall resource efficiency and to exploit opportunities to use energy and / or waste from one process as potential inputs to other processes. The novelty here is the combined simulation of production and building energy use and waste in order to reduce overall resource consumption. The paper presents a literature review, develops the conceptual modelling approach and introduces the prototype IES Ltd <VE> THERM software. The work has been applied to industrial cases to demonstrate the ability of the prototype to support activities towards sustainable manufacturing.

**Keywords:** Sustainable manufacturing, building energy modelling, resource simulation, factory modelling.

## 1 Introduction

The Bruntland report [1] defines sustainable development as meeting the needs of the present generation without compromising the ability of future generations to meet their own needs. Focusing on sustainable manufacturing there is the need to recognise the triple bottom line of social justice (people), environmental quality (planet) and economic prosperity (profit) [2]. There is significant work underway in both academia and industry to develop tools and techniques for sustainable manufacturing and apply them for tangible benefit. As a result of rising prices and concerns over energy security and climate change, energy is a major focus. Documented cases and achievements presented on corporate websites show that

significant benefits can be obtained. However, it is not until a sustainability mindset is adopted that the opportunities can be identified in the first place.

Sustainable manufacturing [3, 4, 5] (based on environmental conscious manufacturing) is broad in scope, taking a high level view of manufacturing and including the triple bottom line elements. Sustainable manufacturing looks beyond the boundaries of one factory and considers the entire material cycle from material extraction through processing and use to subsequent disposal [6, 7]. Most research in sustainable manufacturing has focused on product design and product end-of-life with relatively little research activity focusing on improving manufacturing systems. Subsequently there is an absence of methodologies for manufacturers to generate improvements within their own facilities [8].

Buildings consume a significant amount of energy to provide heating, cooling, ventilation, lighting and power. Individuals in both buildings and manufacturing systems disciplines use methodologies and tools to guide design and reduce resource use including simulation. Buildings and factory facilities are typically suppliers to manufacturing operations and are managed according to different metrics. There is significant potential for improvement by integrating these areas but there is currently a lack of knowledge, skills and tools.

This paper examines tools for manufacturing buildings and manufacturing systems and the methodologies to support their improvement. In the absence of available tools and methods, the paper presents an approach to combine these areas. Prototype work on integrating them along with sustainable manufacturing tactics is introduced.

## **2 Methodology**

The wider aim of this research is to build and apply a modelling tool and assess its applicability. The approach is to use a building and testing cycle by using theories and tools available to create a conceptual model and then simulation modelling tool and to test it in practice.

Literature is drawn from a wide variety of sources in the fields of sustainable manufacturing (SM), sustainable buildings (SB), energy efficiency and modelling. Given that the area is developing both peer reviewed journals as well as commercial sources were used. The literature was used to establish current practice in the SM and SB fields as well as in modelling and simulation.

The modelling approach was developed using literature to capture the Material, Energy and Waste (MEW) flows in a way that they could be represented and modelled both qualitatively and quantitatively. From the conceptual model, a prototype simulation tool developed by extending a commercial building energy software modelling product. Testing used synthetic as well as factory process data.

## **3 Literature**

Perhaps as a consequence of the absence of methodologies to transform manufacturing systems, there is a lack of software tools, such as simulation, to

support the design and analysis of sustainable industrial systems. As with the adoption of lean methodologies and ‘lean/green’ techniques (e.g. [9]), there have been incremental developments in simulation for discrete manufacturing that include energy modelling. As lean methods and manufacturing simulation tools typically capture the visible value-adding processes, the significant energy consuming processes in a factory are ignored. The facilities that supply steam, air and other services are rarely included. Additionally the building that surrounds the manufacturing operations and part of the manufacturing utilities are ignored and considered separately from manufacturing system design.

Building design and refurbishment is regulated and defined by detailed standards and metrics, particularly building codes and voluntary standards such as BREEAM and LEED. As with manufacturing systems design, building design is supported by improvement methods and guiding tools that incorporate sophisticated modelling for areas such as comfort and energy performance.

Currently there are no commercially available tools for manufacturers to assess environmental performance, identify improvement areas and help suggest concrete actions across the breadth of the application area described [10]. Additionally, there are few examples of research [9, 11, 12, 13] to bring these domains together. Such work presents conceptual design and specific simulation but does not offer as much benefit as the combination of improvement methodologies and integrated buildings, utilities and production system modelling.

Any sustainable manufacturing modelling tool must be capable of modelling the interaction between the production system and its physical environment – firstly the building itself (including the effect of external factors such as weather data or surrounding buildings) and the locality. For example, sustainable manufacturing tactics include the potential to use local waste to power production processes, or the transfer of waste heat from production to other parts of the factory [14].

## **4 Modelling considerations**

Within most manufacturing operations (especially discrete product flow) material and energy flows vary over time. For energy the ‘quality’ will also vary (e.g. production of waste heat at a range of temperatures). To understand the interaction of material and energy changes through time and space dynamic modelling is a possibility [9]. Manufacturing simulation tools are commonly used in modelling materials over time and building simulation tools are well established to model energy use and dissipation over time and space.

Extending Discrete Event Simulation (DES) software to include energy has been achieved [15] and can show what energy is used as a result of production activity. Energy use data can be generated from within the model itself, e.g. by an operating machine, or can be generated after a model run by post-processing the output data. Hence energy consumption data can be driven by a combination of shift hours and machine operation hours. Accounting for energy use is valuable as it can educate users as well as quantitatively inform decision making. However, if the energy (and

other resources) are simply accounted for rather than modelled then there is a key drawback; there is no distinction between the input and output of energy.

Modelling the input and output of energy in buildings and production processes is essential to understanding how to make more holistic improvements. The output of energy from production (usually immediately in the form of heat) can impact on the building environment (which can account for up to half a factory's energy consumption). Additionally, understanding what energy is being released (quantity, location, time, quality) is essential for seeking opportunities for reuse. Hence creating building and production models within an energy modelling environment has the potential to model the interaction between those two big energy and other resource consumers. Such modelling could be done in a single modelling software package or from the integration of two specialist packages.

The combination of manufacturing and building simulation techniques is therefore potentially very powerful. For example, they could be used together to understand whether waste heat from air compressors could be used for pre-heating water or whether hot air vented at the end of a process cycle could be used to contribute to space heating in winter. Simulation would be used to understand the potential contribution of waste reuse considering the system complexity and the timing of the heat availability, timing of the heat demand, the heat transfer, spatial aspects, etc.

A software system that combines building simulation with an operational model might use tactics to refer the user to sustainable manufacturing improvements. For example, if the simulation tool was able to model production activity and energy consumption then a comparison of the two could be made and a mismatch could be highlighted. If it was deemed that energy was being used unnecessarily when there was no production (highlighted by a 'tactic') then a link could be made to manufacturing practices to illustrate what solutions other companies implemented.

## 5 Conceptual model

In order to build a tool to support the pursuit of sustainable manufacturing, a conceptual model must be created that captures the key resource flows and transitions within a factory. The factory will include the production processes and the facility that supports the people and equipment within the building. To use the tool it is necessary to have modelling software, a method by which it is used and a repository of practices (or more specifically tactics) on how to improve the model, see Figure 1.

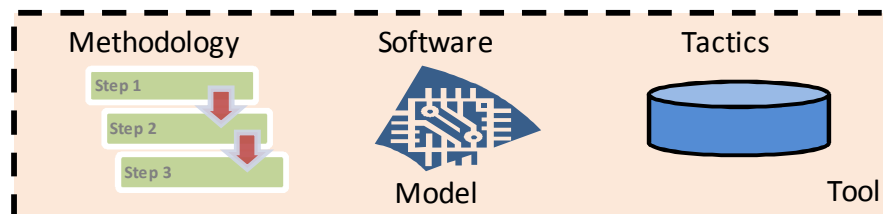

Figure 1. Overview of the modelling tool with method, software and tactics

The software environment will support a model that can contain the utilities and production along with the surrounding building. Some of the utilities will be within the building and some outside. The equipment that consumes and outputs resources are contained within the utilities and production. As the utilities and buildings are potentially affected by the conditions outside the system (or factory) being modelled then the environment is also included. The interrelationships between these modelling components are shown in Figure 2.

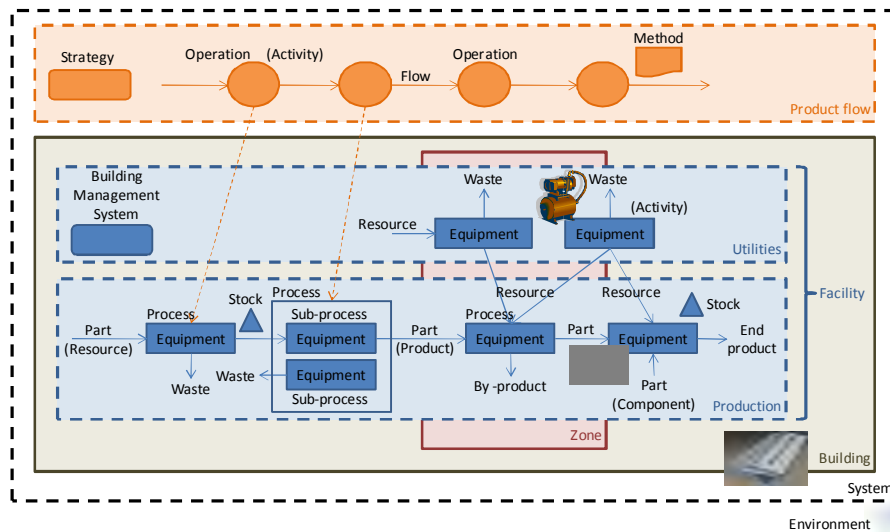

Figure 2. Conceptual model for the software tool

The conceptual model shows the flow of resources through the facility. Parts input and products output are standard elements of production models built in DES software. The building shell and zones within it are standard elements in buildings software. With modelling software that is able to model energy and its transfer then energy and other resources can be modelled for the building (e.g. the heating, ventilation and air conditioning, HVAC) as well as for the production (e.g. the heat and other wastes leaving production equipment).

This generic conceptual model was used to specify the enhancement of existing IES <VE> software to enable the impact of production activity on the wider facility and building to be modelled.

## 6 Industrial Case Study

The modelling approach proposed was applied to an industrial treatment process. The criteria for process selection included: process energy intensity (hence potential for significant savings); inclusion of both production process with surrounding utilities and incorporation of multiple MEW flows. A schematic of the process (Figure 3) was

developed and used as the basis for the conceptual model of the facility and then a simulation model (Figure 4) in the prototype <VE> environment.

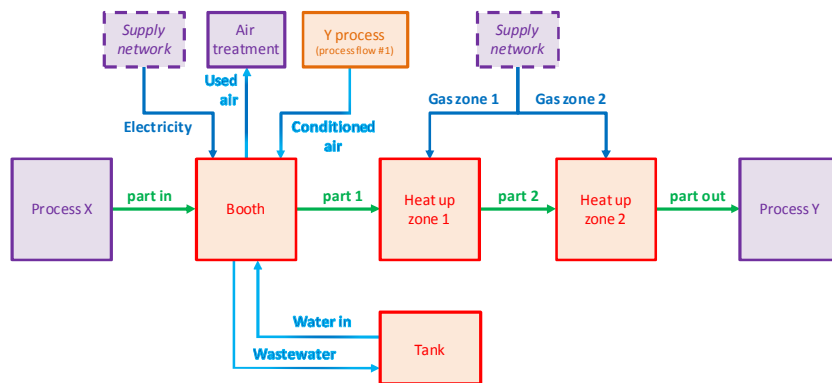

Figure 3. Schematic of the model concept for creation of the software model

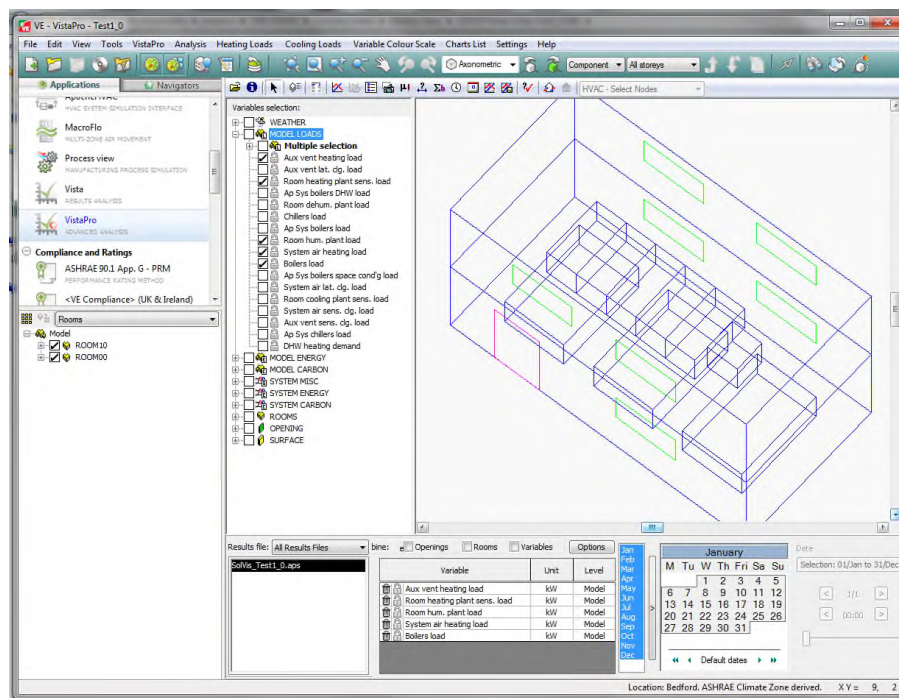

Figure 4. Example of a <VE> building and manufacturing process model

The scale of models containing production and utilities and the complexity of multiple resource flows means that identification of the potential improvements is laborious and skilled. To spot opportunities, users must be able to review each type of flow, their individual timing and their timing relative to other flows based on analysis from first principles as well as experience of other manufacturers'

improvements. To reduce the time and improve the quality of this search tactics [14] are used. A database of tactics was developed from analysis of many hundreds of publicly available sustainable manufacturing practices. The tactics have associated automated tests, e.g. comparing production run activity of a production process with the energy consumption data could highlight the process was consuming energy when not producing product output. The application of tactics is illustrated in Figure 5.

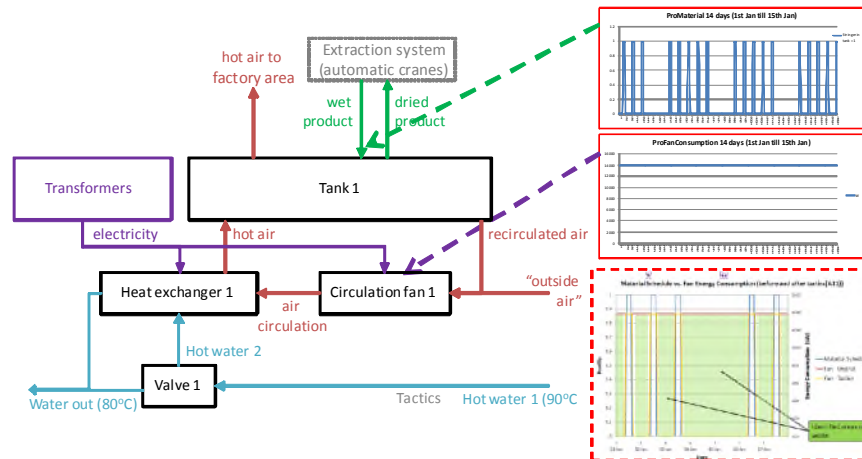

Figure 5. Linking process modelling results to tactics [16]

Simulation of the model demonstrated the ability to model energy flows across buildings, utilities and production systems. In turn greater understanding of energy flows could be gained and improvement opportunities identified.

## 7 Conclusion

This paper has examined work carried out in the field of sustainable manufacturing and its relationship with buildings and utilities. It has been observed that these disciplines are largely considered independently on sustainability projects, potentially missing important opportunities for better overall solutions. The design, operation and improvement activities across this broad area utilise different skills, different improvement approaches and different software.

The paper has documented the concept of a tool and supporting methods for combined analysis of production systems, ancillary support systems and production buildings. In turn broader and more informed decisions could be made on reducing overall material, energy and resource flows by reducing inputs and reusing wastes.

Future work will encompass software development of further modelling functionality, integration of software workflows to match the activities of the improvement teams and integration of best practices available from manufacturers.



## Acknowledgements

The authors would like to thank important contributions from the UK's Technology Strategy Board (TSB) and other individuals in Airbus, IES and Toyota contributing to the TSB funded THrough-life Energy and Resource Modelling (THERM) project.

## References

1. World Commission on Environment and Development, Our common future. Oxford University Press, Oxford, (1987).
2. J. Elkington, Cannibals with Forks: The Triple Bottom Line of 21st Century Business, Capstone Publishing, Oxford, (1997).
3. S. Rahimifard and A.J. Clegg, Aspects of sustainable design and manufacture, *Int J Prod Res*, 45 (18-19) (2007), 4013-4019.
4. G. Seliger, Sustainability in manufacturing: recovery of resources in product and material cycles, Springer, Berlin, (2007).
5. T. Kumazawa and H. Kobayashi, Feasibility study on sustainable manufacturing system, 3rd Int Symposium on Environmentally Conscious Design and Inverse Manufacturing (EcoDesign '03), Tokyo, Japan, (2003), 517.
6. C. O'Brien, Sustainable production – a new paradigm for the millennium. *Int J Prod Econ*, 60-61 (1999), 1-7.
7. J.M. Allwood, What is sustainable manufacturing? Sustainable Manufacturing Seminar Series, 16/2/05. Cambridge Uni, (2005), 1-32.
8. M. Despeisse, P.D. Ball, S. Evans, A. Levers, Industrial ecology at factory level – a prototype methodology, *Proc IMechE, Part B: J Eng Manuf*, 226(10) (2012), 1648-1664.
9. P.D. Ball, S. Evans, A. Levers and D. Ellison, Zero carbon manufacturing facility – towards integrating material, energy, and waste process flows. *Proc Inst Mech Eng Part B J Eng Manuf*, 223(9) (2009), 1085-1096.
10. A.J. Wright, M.R. Oates, R. Greenough, Concepts for the dynamic modelling of energy-related flows in manufacturing, *Int Conf Applied Energy*, 6-8 July, Suzhou (China) (2012).
11. M.Oates, A.Wright, R.Greenough, L.Shao, Understanding resource flows in a factory environment, *Int Conf Sustainable Intelligent Manufacturing (SIM)*, 29 June – 2 July (2011), Leiria, Portugal.
12. J. Hesselbach, C. Herrman, R. Detzer, L. Martin, S. Thiede, B. Lüdemann, Energy efficiency through optimized coordination of production and technical building services, 15th CIRP Int Conf Life Cycle Engineering, Sydney (Australia) 17–19 March (2008).
13. J.L. Michaloski, G. Shao, J. Arinez, K. Lyons, S. Leong and F. Riddick, Analysis of Sustainable Manufacturing Using Simulation for Integration of Production and Building Service, *Symp Simulation for Architecture & Urban Design (SimAUD)* Boston MA (2011).
14. M. Despeisse, P.D. Ball, S. Evans, Modelling and tactics for sustainable manufacturing, *Int Conf Sustainable Intelligent Manufacturing (SIM)*, 29 June – 2 July (2011), Leiria, Portugal
15. P. Solding, P. Thollander, Increased energy efficiency in a Swedish iron foundry through use of discrete event simulation, *Winter Simulation Conference* (2006), 1971-1976.
16. P.D. Ball, M. Despeisse, S. Evans, R.M. Greenough, S.B. Hope, R. Kerrigan, A. Levers, P. Lunt, M.R. Oates, R. Quincey, L. Shao, T. Walt Niel, C. Wheatley, A.J. Wright, Modelling energy flows across buildings, facilities and manuf ops, *Int Manuf Conf*, Dublin, Ireland (2011).