



HAL
open science

A Platform for Disaster Response Planning with Interdependency Simulation Functionality

Abdullah Alsubaie, Antonio Di Pietro, Jose Marti, Pranab Kini, Ting Fu Lin, Simone Palmieri, Alberto Tofani

► **To cite this version:**

Abdullah Alsubaie, Antonio Di Pietro, Jose Marti, Pranab Kini, Ting Fu Lin, et al.. A Platform for Disaster Response Planning with Interdependency Simulation Functionality. 7th International Conference on Critical Infrastructure Protection (ICCIP), Mar 2013, Washington, DC, United States. pp.183-197, 10.1007/978-3-642-45330-4_13 . hal-01456885

HAL Id: hal-01456885

<https://inria.hal.science/hal-01456885v1>

Submitted on 6 Feb 2017

HAL is a multi-disciplinary open access archive for the deposit and dissemination of scientific research documents, whether they are published or not. The documents may come from teaching and research institutions in France or abroad, or from public or private research centers.

L'archive ouverte pluridisciplinaire **HAL**, est destinée au dépôt et à la diffusion de documents scientifiques de niveau recherche, publiés ou non, émanant des établissements d'enseignement et de recherche français ou étrangers, des laboratoires publics ou privés.



Distributed under a Creative Commons Attribution 4.0 International License

Chapter 13

A PLATFORM FOR DISASTER RESPONSE PLANNING WITH INTERDEPENDENCY SIMULATION FUNCTIONALITY

Abdullah Alsubaie, Antonio Di Pietro, Jose Marti, Pranab Kini, Ting Fu Lin, Simone Palmieri and Alberto Tofani

Abstract Catastrophic events can result in great loss of lives and property. Planning an effective disaster response to minimize associated losses is a fundamental challenge for decision makers. The planning process can be improved by simulating interdependent critical infrastructures and evaluating system behavior during disaster scenarios. This paper describes a disaster response planning simulation platform that supports decision making based on the interdependencies existing between a power grid and a supervisory control and data acquisition (SCADA) system. By considering the physical constraints on the power grid and SCADA network, a set of feasible configurations is presented to disaster responders. The utility of the platform is demonstrated using an example scenario involving power distribution to a hospital during a disaster event.

Keywords: Disaster response, interdependencies, simulation

1. Introduction

Implementing disaster response for critical infrastructures is difficult due to their size and complexity. Indeed, developing an effective response plan requires the identification of the associated infrastructure interdependencies. This can be accomplished using simulators to model interactions and assess infrastructure behavior in disaster scenarios.

Interdependency simulators support emergency decision making by modeling system interactions to determine resource requirements and distribution. Consider, for example, a situation where energy is supplied to an electrical load. The system is limited by the maximum current level of the corresponding electrical feeder and cannot exceed a physical threshold. An interdependency

simulator can model the physical characteristics to evaluate the impact at the system level under varying conditions. By simulating each physical system independently (e.g., power grids, telecommunications networks, water distribution and transportation systems), the impact of potential disaster scenarios can be evaluated and response plans developed accordingly.

In earlier work [11], we proposed the adoption of the Disaster Response Network Enabled Platform (DR-NEP), a universal simulation network that integrates heterogeneous user interfaces and software. By linking the Infrastructure Interdependencies Simulator (I2Sim) [12] with a power grid simulator, DR-NEP enables the validation of resource allocation in the electrical domain. I2Sim is an event-driven, time-domain simulator that models resource flow among different infrastructures to determine how the output of one infrastructure is affected by its physical properties and the availability of input resources. The power grid simulator uses a web-service-based distributed simulation platform (WebSimP) and simulates the electrical infrastructure at the functional level.

This paper focuses on the additional resource allocation for a supervisory control and data acquisition (SCADA) communications infrastructure. This is accomplished using a telecommunications simulator along with WebSimP. The approach is demonstrated using a scenario modeled with I2Sim, which involves a power grid and an associated SCADA network that serves a hospital and other loads in a disaster area. The results demonstrate the utility of the interdependency simulator and provide an avenue for future work in disaster preparedness.

2. Related Work

Following Hurricane Katrina, researchers and government agencies began focusing on decision support frameworks to assist emergency planners in visualizing the real-time cascading effects of multiple infrastructure failures in the event of a natural disaster [5, 10]. Such frameworks include disaster support systems that optimize decision making during time-sensitive situations [2, 7, 16]. However, existing disaster support systems do not take into account the important effects of infrastructure interdependencies. Indeed, as disaster responders face increasingly difficult decisions due to the growing size and complexity of critical infrastructures, simulators are needed to evaluate the impact of interdependent systems.

Researchers have adopted a variety of techniques (e.g., agent-based systems, input-output inoperability, system reliability theory, nonlinear dynamics and graph theory) to model different types of interdependency phenomena [4, 14]. Rinaldi, *et al.* [14] have demonstrated that it is possible to distinguish physical, social, logical, geographical and cyber interdependencies. Satumitra, *et al.* [15] have categorized the various interdependency modeling approaches. Ghorbani, *et al.* [8] have presented a classification and comparison of agent-based interdependency modeling and simulation tools. Our work leverages I2Sim [12], a cell-channel model framework. I2Sim uses an integrated interdependency

simulator as the underlying framework for infrastructure recovery and coordination [13]. Decision makers can use the framework to verify different resource allocation strategies and to simulate the effects of different event sequences. In turn, I2Sim uses domain-specific simulators to verify the feasibility of resource allocation strategies.

In our simulation, we consider scenarios that involve dependencies between an electrical power grid and a SCADA system. A proprietary network and a public telecommunications network represent a typical communications infrastructure for a SCADA system. As noted in [1], such a solution guarantees adequate performance with respect to transmission bandwidth, but it introduces a number of potential failure points that did not exist previously. Several approaches have been proposed in the literature to better understand the potential vulnerabilities and risks. As an example, the hierarchical holographic modeling approach [9] expresses a complex system at different hierarchical levels, including the physical, organizational and managerial levels. This approach has been applied to SCADA systems in order to evaluate the risk of cyber attacks on controlled critical infrastructures [6]. One of the most promising tools for investigating SCADA system interdependencies is the Virtual Control System Environment, a hybrid simulator that is used to analyze the effects of cyber security vulnerabilities of control systems used in the power grid [18].

There is growing interest in modeling and simulation frameworks for investigating the dependencies existing between SCADA systems, the controlled infrastructure (e.g., oil and gas distribution networks and power grids) and the underlying telecommunications infrastructure. Bobbio, *et al.* [1] have proposed a general framework that shows how the power supply to customers depends on the availability of SCADA services that, in turn, depend on the availability of a communications network. Each network is expressed using by a stochastic modeling formalism that helps evaluate assumptions made about failure and recovery mechanisms.

Ciancamerla, *et al.* [3] have computed quality of service indicators for a fault isolation and system restoration procedure applied to a realistic power grid and SCADA system. The procedure detects and isolates faults in the power distribution grid and reconfigures the grid to reconnect isolated customers. This paper focuses on fault isolation and system restoration procedures for managing a damaged power grid with the objective of maintaining power to most of the critical infrastructures in the area (e.g., hospitals).

3. Disaster Response Planning Platform

The disaster response planning platform is intended to assist emergency responders in planning effective responses based on the interdependencies existing between a power grid and a SCADA network. The platform has three main components: (i) Disaster Response Network Enabled Platform (DR-NEP); (ii) Infrastructure Interdependency Simulator (I2Sim); and (iii) Web-Service-Based Simulation Platform (WebSimP).

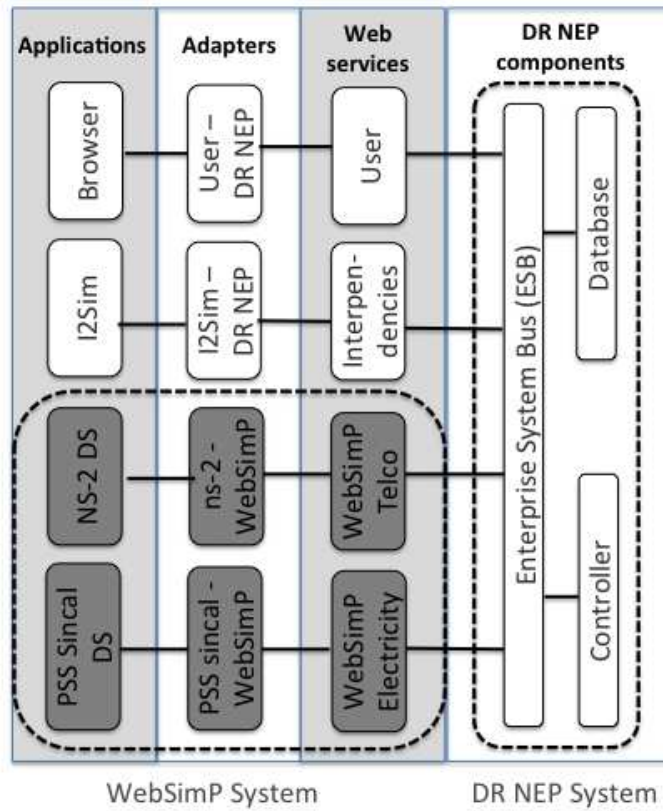

Figure 1. DR-NEP architecture.

3.1 DR-NEP Architecture

DR-NEP is a web service platform that enables different simulators to communicate results to each other via a common enterprise service bus (ESB) and a database. A distributed computing architecture (Figure 1) is employed to support decision making. Every simulator is connected to DR-NEP using an adapter that listens on the ESB for instructions about running simulations, gathers inputs from the other simulators and the database and pushes results from the simulators to the database. After the simulators and adapters are configured, a controller in the ESB pushes input to the simulators at predefined intervals.

DR-NEP also offers web pages and mapping services for researchers and disaster responders to support coordination, resource flow visualization and infrastructure operability.

3.2 I2Sim

I2Sim is an event-driven, time-domain simulator that is used to model infrastructure interdependencies. I2Sim uses a cell-channel approach, which provides a multi-system representation at multiple hierarchical levels (e.g., local, municipal and provincial). The simulator assesses in real time the effects of resource allocation decisions during disasters [12]. The DR-NEP platform enables I2Sim to exchange inputs and outputs with other domain simulators via software adapters.

3.3 WebSimP

WebSimP enables the domain simulators that are integrated with DR-NEP to be invoked separately through web service technologies. Such a service-based platform offers many benefits over other types of distributed computing architectures in terms of interoperability and ubiquity. As shown in Figure 1, WebSimP allows the simulation of the electrical and telecommunications domains.

Each simulation layer incorporates three software components: (i) a web service that receives operation requests to execute a particular simulation; (ii) a software adapter that implements the details of each requested operation and oversees command execution in the simulator and output data post-processing; and (iii) a simulator (e.g., discrete/continuous, deterministic/stochastic) that executes a simulation model for a certain domain.

Electrical Adapter. The electrical adapter is a software component that is responsible for invoking operations in a pre-existing model. The possible operations are: (i) network configuration (e.g., disconnecting electrical lines to simulate line damage and closing breakers to simulate load shedding actions); and (ii) constraint computation (e.g., maximum available power). The simulator determines the loads that the grid may support without damaging the infrastructure by considering physical limits on parameters such as current and voltage. The PSS Sincal [17] electrical simulator is used; it supports network planning for power transmission and distribution networks (e.g., load flow calculations, dynamics and network protection).

Telecommunications Adapter. The telecommunications adapter is a software component that is in charge of invoking operations in a pre-existing telecommunications simulation model. The possible operations are: (i) network configuration (e.g., disconnecting telecommunications and SCADA elements to simulate damage events); (ii) constraint computation (e.g., communications bandwidth); and (iii) electrical network reconfiguration time computation (e.g., response time required to send and execute specific commands). The telecommunications simulation uses ns-2, a discrete event simulator that allows the modeling and simulation of communications protocols, routing and multicast protocols over wired and wireless networks.

4. Resource Allocation Process

The DR-NEP platform presents decision makers with a set of feasible options. The three simulators, I2Sim, PSS Sincal and ns-2, are used to model disaster events.

I2Sim models a disaster event at a high level and assesses the effects of resource allocation. In a disaster scenario, I2Sim maximizes the functionality of critical infrastructures (e.g., hospitals) by optimizing resource allocation. Different resources can be incorporated in I2Sim models, such as electricity, water, medicine and transportation. This paper focuses on the determination of the distribution of electricity using power grid and SCADA network (domain) simulators.

The power grid is modeled using PSS Sincal, which simulates the status of the power system during a disaster event and examines the feasibility of possible configurations. The possible configurations include the power required to supply a load, electrical equipment used, power grid limits, and control elements of the SCADA communications network.

Resource allocation begins with I2Sim suggesting the desired resource distribution required to supply a specific amount of electricity to a critical load (e.g., a hospital). Decisions are determined based on the I2Sim optimization process, which considers other resources and critical infrastructures. PSS Sincal and ns-2 simulate the possible configurations that can accommodate an I2Sim request and return a feasible configuration via the WebSimP adapter. Note that the feasible configuration may or may not satisfy the initial request made by I2Sim. If all the conditions are not satisfied, I2Sim updates its model and selects another request. PSS Sincal and ns-2 then simulate the configurations once again and return a feasible solution. The process continues iteratively to optimize the power distribution to critical infrastructures based on the power grid and SCADA network constraints.

5. Sample Scenario

The sample scenario involves a disaster event where the power and SCADA infrastructures place constraints on the resource allocation process. The main objective in the scenario is to maximize the operability of a hospital by providing the required electricity and water resources. The I2Sim simulates the interdependencies between the hospital and the water pumping station. PSS Sincal and ns-2 simulate the physical constraints introduced by the power and SCADA networks.

In more complex situations, the failure of a power provider would affect multiple critical infrastructures. However, for demonstration purposes, we consider a small set of infrastructure entities. Note that the DR-NEP platform can be readily extended to run a simulation scenario where multiple infrastructures concurrently depend on a single power provider.

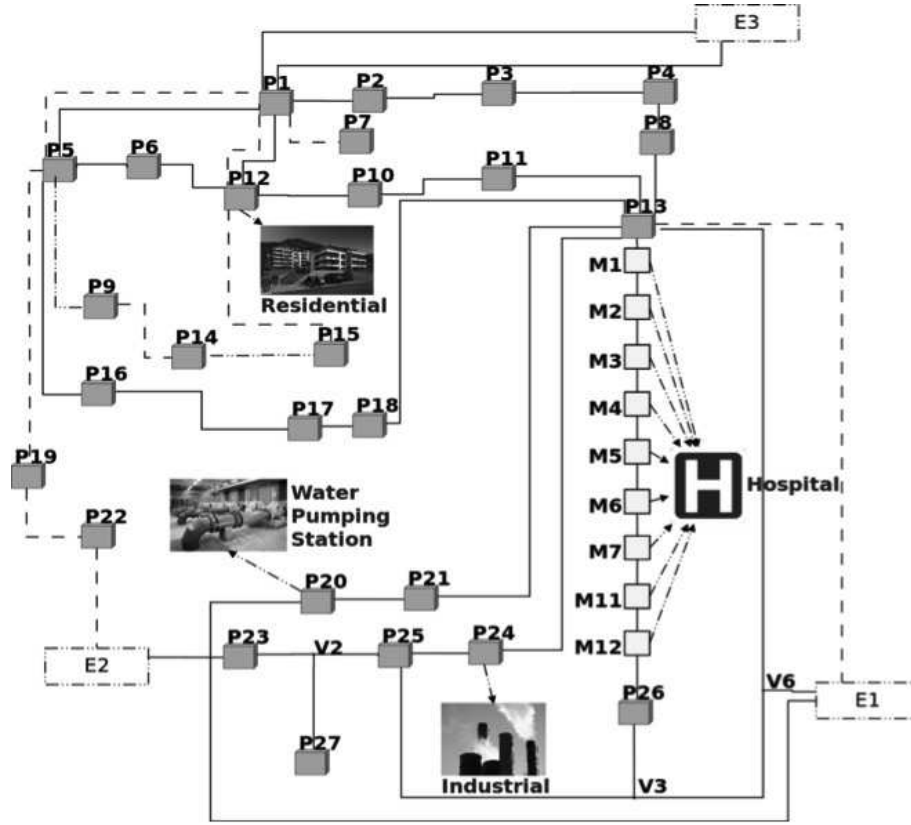

Figure 2. Power distribution grid.

5.1 Infrastructure Simulation Models

This section describes the power distribution grid, SCADA system and I2Sim simulation models.

Power Distribution Grid. The power distribution grid shown in Figure 2 incorporates 165 buses, 22 circuit breakers and 46 loads. E_i nodes represent the power transmission grid substations, P_i nodes represent high voltage (HV) 150 kV buses, M_i nodes represent the medium voltage (MV) 20 kV buses, and physical links between two buses represent electrical lines. Each substation supplies energy to different types of loads/customers: (i) public loads/customers for the hospital, including emergency and intensive care units with very high criticality (M_{11} and M_{12}) and other hospital units (M_1, \dots, M_7); (ii) industrial loads/customers for a water pumping station and an industrial load (P_{20} and P_{24}); and (iii) residential loads/customers for domestic users (P_{12}).

In normal conditions, hospital loads are supplied by P_{13} and P_{26} through intermediate nodes M_i . In the event of a physical failure of P_{13} , the hospital

Table 1. Electricity demand for loads/customers.

Physical Entity	Electricity Demand (MW)
Hospital	13.47
Water Pumping Station	52.50
Industrial	9.47
Residential	120.91

is fed only through P_{26} . Since P_{26} can supply a maximum of 9.50 MW, load shedding actions must be initiated by the SCADA system to supply the hospital loads (Table 1).

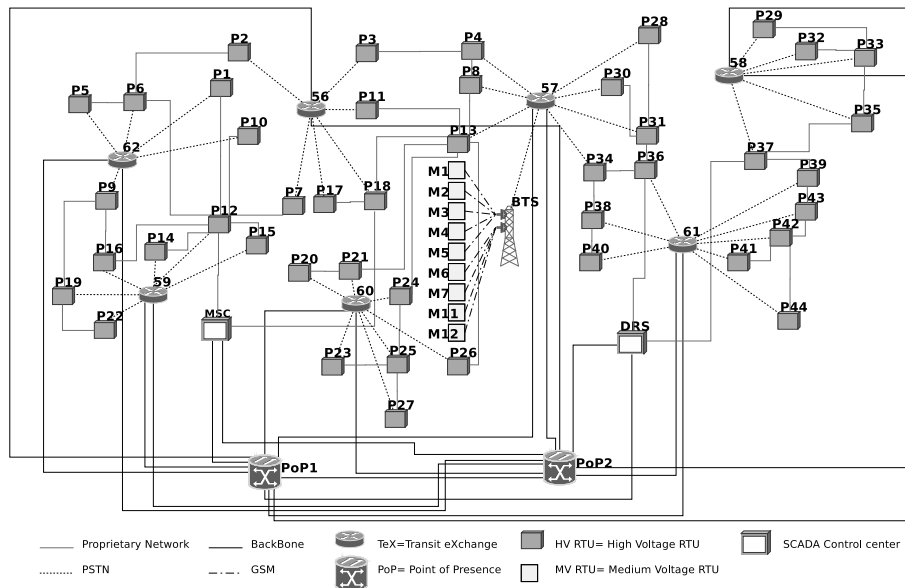

Figure 3. SCADA system.

SCADA System. Figure 3 shows the SCADA system that controls the power distribution grid. The SCADA system includes: (i) a main SCADA control (MSC) center that controls and supervises the power distribution grid; (ii) a disaster recovery SCADA (DRS) center that assumes control and supervision in case of MSC failure; (iii) 44 remote terminal units (RTUs) (P_i nodes) located at HV substations; and (iv) nine RTUs (M_i nodes) located at MV substations. RTUs receive commands through the SCADA communications network from the MSC and DRS centers to perform local actions on the power grid (e.g., closing circuit breakers).

Table 2. SCADA network model assumptions.

Link Type	Proprietary Network	PSTN	Backbone
Capacity	0.5 Mbps	0.5 Mbps	1 Mbps
Source-Destination Nodes	$MSC - P_i,$ $DRS - P_i,$ $P_i - P_j,$ $P_i - M_j,$ $M_i - M_j$	$TeX_i - P_j$	$PoP_i - PoP_j,$ $PoP_i - TeX_j,$ $MSC - PoP_i,$ $DRS - PoP_i$
Traffic Type	CBR over TCP	CBR over TCP	CBR over TCP
Traffic Bit Rate	255 B/30 sec	255 B/30 sec	255 B/30 sec

The SCADA communications network comprises two networks:

- The default proprietary network (DPN) connects the SCADA control centers to RTUs at the HV and MV substations. DPN nodes can also communicate with each other through the public switched telephone network (PSTN) to provide backup capabilities.
- The PSTN network models the public backup telecommunications network that connects the MSC and DRS to the HV RTUs. Two virtual private networks (VPNs) are established between the MSC and DRS via two high data rate digital subscriber line connections that employ two points of presence (PoPs), PoP_1 and PoP_2 .

Communications between the MSC and DRS and the RTUs are modeled with ns-2 using TCP agents located at the source and destination nodes. Traffic is generated at a specified constant bit rate (CBR). Table 2 summarizes the main assumptions.

I2Sim Model. The I2Sim model provides a high-level abstraction of the physical components. The detailed topological configurations of the power and SCADA networks are modeled using the domain simulators, PSS Sincal and ns-2, respectively. In the I2Sim ontology, physical infrastructure entities are modeled as cells connected by channels that transport resources (e.g., electricity and water). In the model shown in Figure 4, eight cells are used to represent interdependent infrastructures at the disaster site, consisting of four electrical substations, a water pumping station, a hospital, residential loads and industrial loads. Note that a backup power supply, which is typically used in a hospital, can be modeled but is not included in this scenario.

The WebSimP electrical adapter and telecommunications adapter implement the mappings between the three models using the DR-NEP database. The database has three primary components: (i) models; (ii) physical entities; and (iii) ports. A model has one or more physical entities, with every physical entity having input and output ports. In our implementation, three models

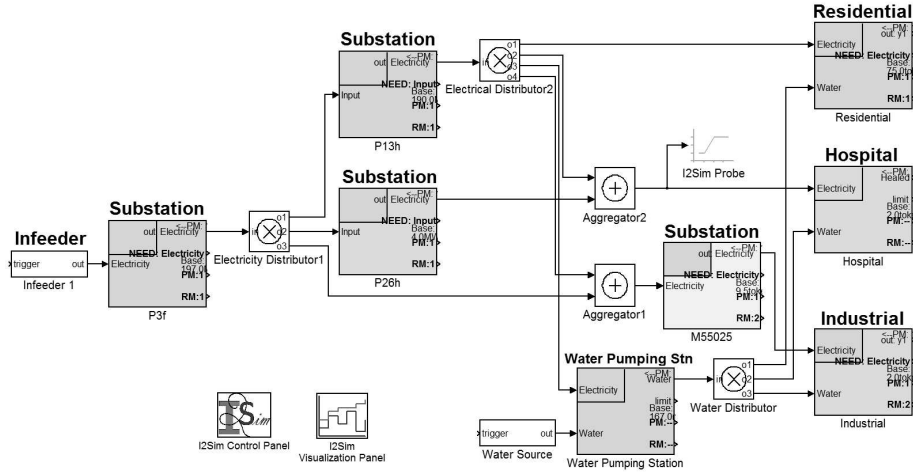

Figure 4. I2Sim model.

are defined in the database, one for each simulator. The output ports of one simulator serve as inputs to the other simulators. After the setup is complete, the port replication module implemented in DR-NEP uses these definitions and automates the process of mapping outputs to inputs at each time-step during the simulation. Note that this reduces the complexity of feeding and collecting data manually in large interconnected systems.

5.2 Simulated Scenarios

Three scenarios are simulated to illustrate the utility of the DR-NEP platform. All three scenarios involve a transformer failure in the power grid. However, two of the scenarios, Scenario 2 and Scenario 3, are more severe in that they also involve failures of SCADA network components.

- Scenario 1: A failure in the power grid (transformer) only.
- Scenario 2: A failure in the power grid (transformer) with a failure in the SCADA network (RTU).
- Scenario 3: A failure in the power grid (transformer) with two failures in the SCADA network (RTU and communications node).

Table 3 shows the sequence of events for the three scenarios. At time T2, failures are introduced: a transformer in Scenario 1; a transformer and an RTU in Scenario 2; and a transformer, RTU and communications node in Scenario 3. At time T3, a desired configuration of the power grid, selected by I2Sim, is sent to the domain simulators for verification. Note that the desired configuration is selected based on optimality, experience and pre-determined feasibility of the power grid and SCADA networks.

Table 3. Sequence of events for the simulated scenarios.

No.	Time	Event	Effect
1	T1	Normal operation	Hospital and water pumping station have full supply of electricity and water
2	T2	Equipment failure is detected	Hospital loads lose 6.2 MW of supply
3	T3	Feasible power grid configuration is implemented	Hospital and water pumping station loads are partially supplied
4	T4	Affected equipment is restored	Full supply can be restored
5	T5	Normal operation configuration is restored	Hospital and water pumping station have full supply of electricity and water

The I2Sim ontology defines operability in terms of available resources in human readable tables with five levels: 100%, 75%, 50%, 25% and 0%. Note that the hospital and water pumping station require 100% power supply for full operability. However, 100% power supply may not be possible during disasters due to damage to the physical systems. In such situations, different combinations of the distributions of available resources can be deployed (e.g., 75% power supply to the hospital and 50% power supply to the water pumping station).

In the three scenarios, the distribution of electricity between the hospital and the water pumping station is determined based on the physical constraints of the power grid and SCADA networks. For example, Table 4 shows the feasible configurations for 100% power supply to the water pumping station and different power supply percentages to the hospital.

5.3 Simulation Results

Based on the five levels in the human readable tables, there are $5 \times 5 = 25$ possible combinations for electricity distribution between the hospital and the water pumping station. However, the failures in the power grid and SCADA networks limit the set of feasible configurations. Table 5 compares the decision spaces for the three simulated scenarios in terms of the number of feasible configurations available for each scenario. The rows represent the levels of power supplied to the hospital and the columns represent the levels of power supplied to the water pumping station. The boldface **X** symbols denote the feasible combinations for electricity distribution. In Scenario 1, for example,

Table 4. Feasible configurations for 100% power supply to the water pumping station.

No.	Power Supply	Feasible Configurations
1	100%	Configuration 1: Breakers P_{10} , P_{13} and P_{26} closed; Breakers $M_1 - M_{12}$ closed
2	75%	Configuration 2: Breaker P_{13k} open; Breaker P_{26} closed; Breakers $M_1, M_2, M_5, M_6, M_{11}, M_{12}$ closed; Breakers M_3, M_4, M_7 open Configuration 3: Breaker P_{13} open; Breaker P_{26} closed; Breakers $M_1, M_2, M_3, M_5, M_{11}, M_{12}$ closed; Breakers M_4, M_6, M_7 open Configuration 4: Breaker P_{13} open; Breaker P_{26} closed; Breakers $M_5, M_6, M_7, M_{11}, M_{12}$ closed; Breakers $M_1 - M_4$ open
3	50%	Configuration 5: Breaker P_{13} open; Breaker P_{26} closed; Breakers M_1, M_2, M_{11}, M_{12} closed; Breakers $M_3 - M_7$ open
4	25%	Configuration 6: Breaker P_{13} open; Breaker P_{26} closed; Breakers M_{11}, M_{12} closed; Breakers $M_1 - M_7$ open
5	0%	Configuration 7: Breakers P_{13} and P_{26} open

a maximum 75% power supply can be delivered to the hospital and the water pumping station.

Table 6 presents the results of the resource allocation process. Note that EF denotes electrical feasibility, SF denoted SCADA feasibility, GF denotes global feasibility and Rt denotes reconfiguration time. Configuration 1 in Scenario 1 is not electrically feasible because feeder P_{13} is isolated from the network by the transformer failure and the power needed to supply all the M_i loads cannot be provided through feeder P_{26} because of the electrical constraints (P_{26} cannot exceed 9.50 MW capacity).

On the other hand, Configuration 2 in Scenario 1 has global feasibility (marked with a boldface **Yes**). This means that all the components of the power grid are within their physical limits and a communication path between the MSC and RTUs is available.

The time required for reconfiguring the power grid was computed by considering the physical time needed to open/close breakers plus the SCADA message round trip time (RTT). The simulated scenarios show that the RTT is negligible with respect to breaker operation. The open/close operations take 50 seconds for MV breakers and 100 seconds for HV breakers.

Table 5. Decision spaces for the three scenarios.

Scenario 1					
	100%	75%	50%	25%	0%
100%	X	X	X	X	X
75%	X	X	X	X	X
50%	X	X	X	X	X
25%	X	X	X	X	X
0%	X	X	X	X	X

Scenario 2					
	100%	75%	50%	25%	0%
100%	X	X	X	X	X
75%	X	X	X	X	X
50%	X	X	X	X	X
25%	X	X	X	X	X
0%	X	X	X	X	X

Scenario 3					
	100%	75%	50%	25%	0%
100%	X	X	X	X	X
75%	X	X	X	X	X
50%	X	X	X	X	X
25%	X	X	X	X	X
0%	X	X	X	X	X

Table 6. Simulation results.

Scenario	Configuration	EF	SF	GF	Rt (sec)
Scenario 1	1 (100%)	No	Yes	No	-
	2 (75%)	Yes	Yes	Yes	420.4
Scenario 2	1 (100%)	No	No	No	-
	2 (75%)	Yes	No	No	-
	3 (50%)	Yes	No	No	-
	4 (50%)	Yes	Yes	Yes	367.4
Scenario 3	1 (100%)	No	No	No	-
	2 (75%)	Yes	No	No	-
	3 (50%)	Yes	No	No	-
	4 (50%)	Yes	No	No	-
	5 (50%)	Yes	No	No	-
	6 (25%)	Yes	No	No	-
	7 (0%)	Yes	Yes	Yes	0

6. Conclusions

The disaster response planning simulation platform described in this paper provides decision support based on the interdependencies existing between a power grid and a SCADA system. The platform integrates a PSS Sincal power grid simulator and an ns-2 SCADA network simulator with an I2Sim infrastructure interdependency simulator using software adapters. The platform offers a powerful interactive simulation environment for disaster response planning, enabling planners to evaluate specific scenarios and select the appropriate responses. The platform also supports the use of simulation results for real-time disaster response.

Scenarios involving cascading events that arise from interdependencies existing with other infrastructures can be simulated by extending the platform architecture. This feature will be implemented in future work. The modular approach used in designing the platform supports the implementation of this feature as well as expanding the framework by adding more domain simulators and inter-system adapters.

References

- [1] A. Bobbio, G. Bonanni, E. Ciancamerla, R. Clemente, A. Iacomini, M. Minichino, A. Scarlatti, R. Terruggia and E. Zendri, Unavailability of critical SCADA communication links interconnecting a power grid and a telco network, *Reliability Engineering and System Safety*, vol. 95(12), pp. 1345–1357, 2010.
- [2] G. Brown and A. Vassiliou, Optimizing disaster relief: Real-time operational and tactical decision support, *Naval Research Logistics*, vol. 40(1), pp. 1–23, 1993.
- [3] E. Ciancamerla, C. Foglietta, D. Lefevre, M. Minichino, L. Lev and Y. Shneck, Discrete event simulation of QoS of a SCADA system interconnecting a power grid and a telco network, in *What Kind of Information Society? Governance, Virtuality, Surveillance, Sustainability, Resilience*, J. Berleur, M. Hercheiu and L. Hilty (Eds.), Springer, Heidelberg, Germany, pp. 350–362, 2010.
- [4] S. De Porcellinis, S. Panzieri and R. Setola, Modeling critical infrastructure via a mixed holistic reductionistic approach, *International Journal of Critical Infrastructures*, vol. 5(1/2), pp. 86–99, 2009.
- [5] D. Dudenhoeffer, M. Permann and M. Manic, CIMS: A framework for infrastructure interdependency modeling and analysis, *Proceedings of the Winter Simulation Conference*, pp. 478–485, 2006.
- [6] B. Ezell, Y. Haimes and J. Lambert, Risks of cyber attack to water utility supervisory control and data acquisition (SCADA) systems, *Military Operations Research*, vol. 6(2), pp. 23–33, 2001.

- [7] F. Fiedrich, F. Gehbauer and U. Rickers, Optimized resource allocation for emergency response after earthquake disasters, *Safety Science*, vol. 35(1), pp. 41–57, 2000.
- [8] A. Ghorbani and E. Bagheri, The state of the art in critical infrastructure protection: A framework for convergence, *International Journal of Critical Infrastructures*, vol. 4(3), pp. 215–244, 2008.
- [9] Y. Haimes and D. Li, A hierarchical-multiobjective framework for risk management, *Automatica*, vol. 27(3), pp. 579–584, 1991.
- [10] Idaho National Laboratory, CIPR/sim: A comprehensive, real-time critical infrastructure modeling technology, Idaho Falls, Idaho (www.hsd1.org/?view\&did=21965).
- [11] J. Marti, P. Kini, P. Lusina, A. Di Pietro, V. Rosato, B. Charnier and K. Wang, Inter-system software adapter for decision support by interfacing disaster response platforms and simulation platforms, *Proceedings of the IEEE Global Humanitarian Technology Conference*, pp. 41–46, 2012.
- [12] J. Marti, C. Ventura, J. Hollman, K. Srivastava and H. Juarez, I2Sim modeling and simulation framework for scenario development, training and real-time decision support of multiple interdependent critical infrastructures during large emergencies, presented at the *NATO RTO Modeling and Simulation Group Conference*, 2008.
- [13] P. Pederson, D. Dudenhoeffer, S. Hartley and M. Permann, Critical Infrastructure Interdependency Modeling: A Survey of U.S. and International Research, INL/EXT-06-11464, Idaho National Laboratory, Idaho Falls, Idaho, 2006.
- [14] S. Rinaldi, J. Peerenboom and T. Kelly, Identifying, understanding and analyzing critical infrastructure interdependencies, *IEEE Control Systems*, vol. 21(6), pp. 11–25, 2001.
- [15] G. Satumitra and L. Duenas-Osorio, Synthesis of modeling and simulation methods in critical infrastructure interdependency research, in *Sustainable and Resilient Critical Infrastructure Systems*, K. Gopalakrishnan and S. Peeta (Eds.), Springer, Heidelberg, Germany, pp. 1–51, 2010.
- [16] J. Sheu, L. Lan and Y. Chen, A novel model for quick response to disaster relief distribution, *Proceedings of the Eastern Asia Society for Transportation Studies*, vol. 5, pp. 2454–2462, 2005.
- [17] SimTec, PSS SINCAL Platform, Leobersdorf, Austria (www.simtec-gmbh.at/sites_en/sincal_updates.asp).
- [18] J. Stamp, V. Urias and B. Richardson, Cyber security analysis for the power grid using the virtual control systems environment, *Proceedings of the IEEE Power and Energy Society General Meeting*, 2011.