



HAL
open science

Theoretical and Numerical Study of Cardiac Electrophysiology Problems at the Microscopic Scale.

Pierre-Elliott Bécue, Florian Caro, Mark Potse, Yves Coudière

► **To cite this version:**

Pierre-Elliott Bécue, Florian Caro, Mark Potse, Yves Coudière. Theoretical and Numerical Study of Cardiac Electrophysiology Problems at the Microscopic Scale.. SIAM Conference on the Life Sciences (LS16), Jul 2016, Boston, United States. hal-01405837

HAL Id: hal-01405837

<https://inria.hal.science/hal-01405837v1>

Submitted on 30 Nov 2016

HAL is a multi-disciplinary open access archive for the deposit and dissemination of scientific research documents, whether they are published or not. The documents may come from teaching and research institutions in France or abroad, or from public or private research centers.

L'archive ouverte pluridisciplinaire **HAL**, est destinée au dépôt et à la diffusion de documents scientifiques de niveau recherche, publiés ou non, émanant des établissements d'enseignement et de recherche français ou étrangers, des laboratoires publics ou privés.

Theoretical and Numerical Study of Cardiac Electrophysiology

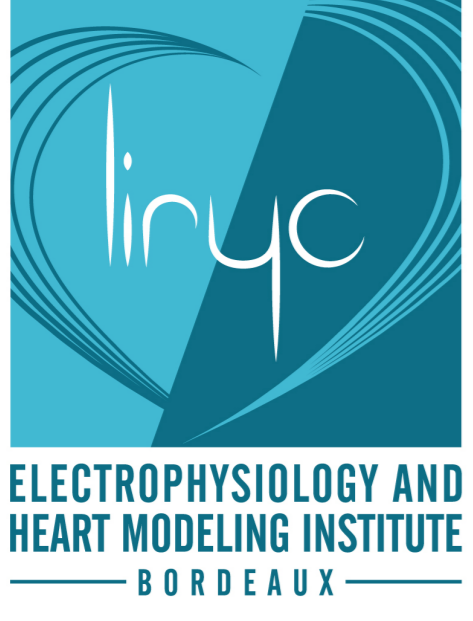

Problems at the Microscopic Scale.

Pierre-Elliott BÉCUE

Florian Caro, Mark Potse, Yves Coudière

pierre-elliott.becue@inria.fr



Summary

We present a microscopic scale model for the propagation of electric waves in human ventricle cells. We achieved a mathematical analysis of this model and show the existence of a weak solution.

Context

- Modeling studies of cardiac electrophysiology essentially rely on homogenized models like monodomain and bidomain models [?];
- Homogenized models cannot take microscopic alterations into account, and cannot represent the nonlinear behaviour of gap junctions between the cells;
- Heart tissue cells constitute a network of cells connected via these gap junctions (see figure), which behave as ionic channels, but between two cells instead of one cell and the extracellular medium.

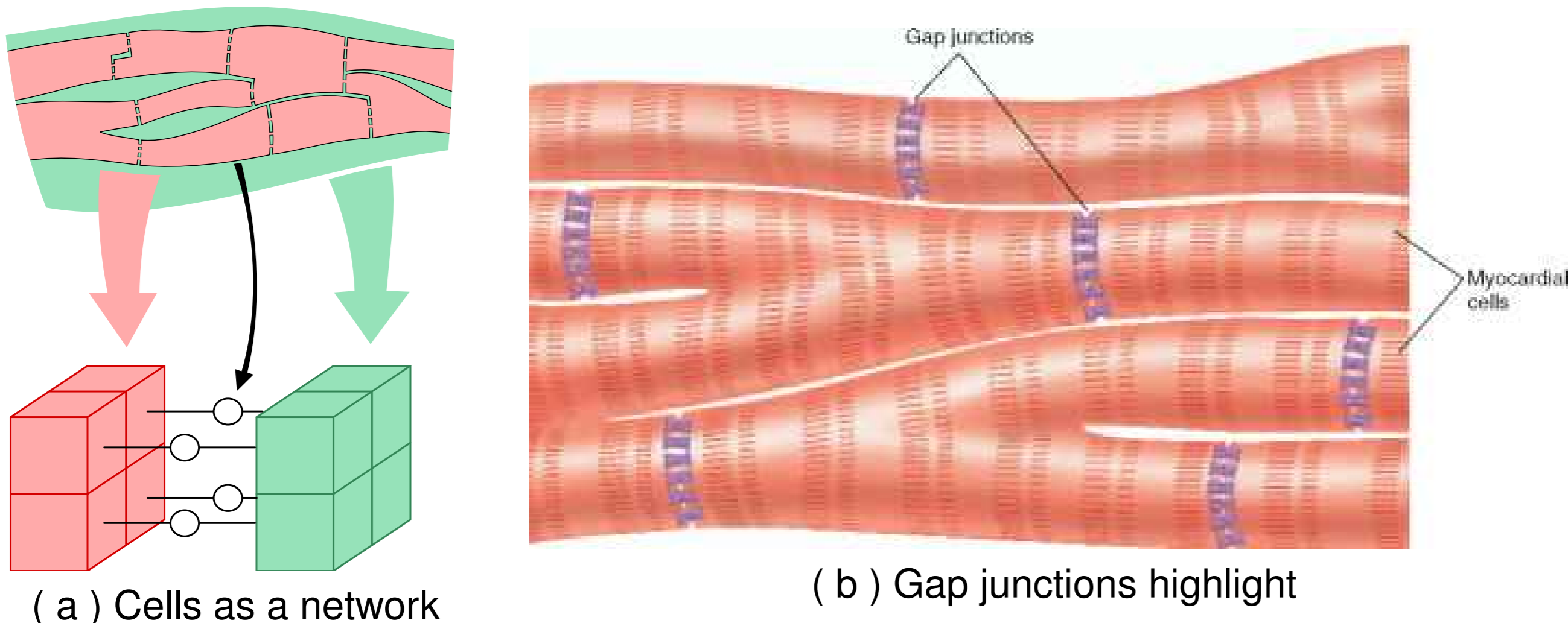

- Dimensions for one cell: length: 175 μm , width: 20 μm , membrane thickness: 10 nm , spacing between neighbours: 1 nm . This leads to experimental and computational challenges;
- Malfunctions and inhomogeneities in heart tissue may lead to alterations in the wave propagation [?];
- Microscopic cardiac conduction has been studied experimentally [?] and numerically [?, ?], but numerical studies have been limited to simplified 2-dimensional monodomain models.

Purpose

- Develop a new 3-dimensional, structurally realistic model formulation with separate intracellular and extracellular domains.
- Get a better understanding of the consequences of microscopic alterations in the heart;
- Simulate the model efficiently, via domain decomposition methods.

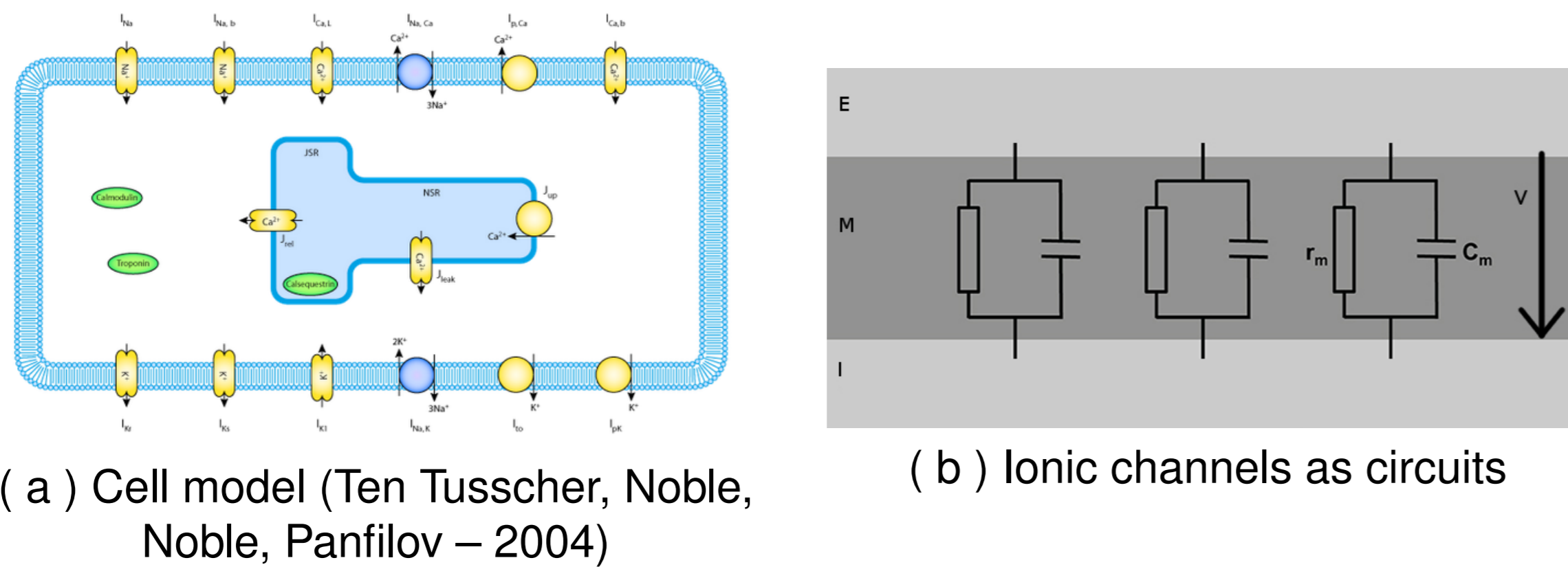

A first microscopic mathematical model

Model

We study the problem on a finite time interval $[0; T]$ at the cellular scale using the following sketch

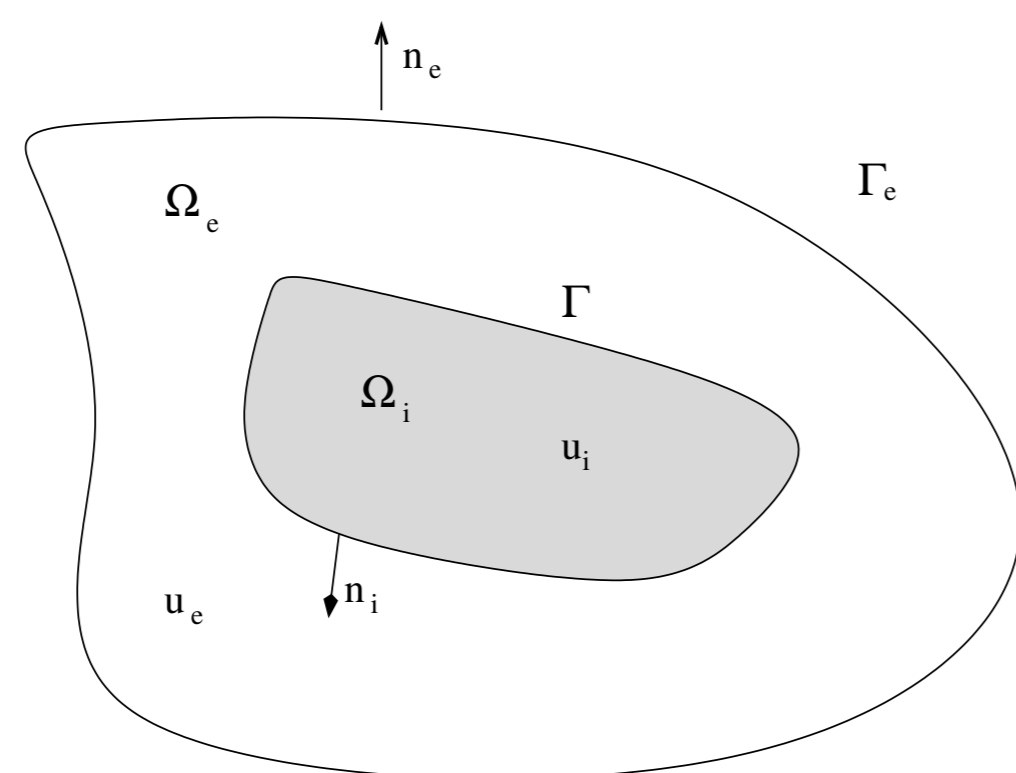

σ_i and σ_e are respectively intracellular and extracellular conductivity. u_i, u_e intracellular/extracellular potential. I_{ion} is the ionic current per unit of membrane area. c_m is the electrical capacitance of the membrane per unit of area. With $v := u_i - u_e$, the model reads

$$\begin{cases} -\nabla \cdot (\sigma_j \nabla u_j) = 0 & \text{in } [0; T] \times \Omega_j, \text{ with } j = i, e \\ \sigma_e \nabla u_e \cdot n_e = 0 & \text{on } [0; T] \times \Gamma_e, \\ -\sigma_i \nabla u_i \cdot n_i = \sigma_e \nabla u_e \cdot n_e & \text{on } [0; T] \times \Gamma, \\ = c_m \partial_t v + I_{\text{ion}}(v, w) & \text{on } [0; T] \times \Gamma. \\ v(0, x) = v_0(x) & \text{on } \Gamma \end{cases} \quad (1)$$

This model presents specific issues

- The ionic term I_{ion} is nonlinear, and also depends on gating variables;
- The boundary coupling conditions on the membrane include a time derivative, which is not proven to be defined.

Analysis of the microscopic model

Hypotheses

- Conductivity tensors σ_i and σ_e are uniformly continuous and coercive

$$\exists m_j, M_j > 0, \forall (x, y) \in \mathbb{R}^3, m_j \|y\|^2 < (\sigma_j(x)y, y) < M_j \|y\|^2 \text{ for } j = i, e;$$

- I_{ion} is Lipschitz-continuous with coefficient λ and $I_{\text{ion}}(0) = 0$.

Weak problem and main result

There exists a solution $(u_i, u_e) \in L^2([0; T]; H^1(\Omega_i)) \times L^2([0; T]; H^1(\Omega_e))$ of

$$\begin{aligned} \int_0^T \int_{\Omega_i} \sigma_i \nabla u_i \cdot \nabla \varphi_i dx dt + \int_0^T \int_{\Omega_e} \sigma_e \nabla u_e \cdot \nabla \varphi_e dx dt + \int_{\Gamma} c_m v_0 \tilde{\varphi}(t=0) dx \\ - \int_0^T \int_{\Gamma} c_m v \partial_t \tilde{\varphi} dx dt + \int_0^T \int_{\Gamma} I_{\text{ion}}(v) \tilde{\varphi} dx dt = 0. \end{aligned} \quad (2)$$

for all $\varphi_j \in L^2(0, T; H^1(\Omega_j))$, $j = i, e$ and $\tilde{\varphi} := (\varphi_i - \varphi_e)|_{\Gamma} \in L^2(0, T; H^{1/2}(\Gamma))$, that is also solution of (1).

Sketch of a proof

- Use a time discretisation for the temporal term $\partial_t v$ on the interface in order to obtain an elliptic problem;
- Use the Lax — Milgram theorem in order to obtain a unique solution;
- Calculate energy estimates especially on time increments of v ;
- Via a compactness argument, prove the weak convergence of a time-rebuilt solution;
- Pass to the limit in the rebuilt problem.

Possible model enhancement

A representation of gap junctions (Credit: Mariana Ruiz, 2006) is given in the following figure

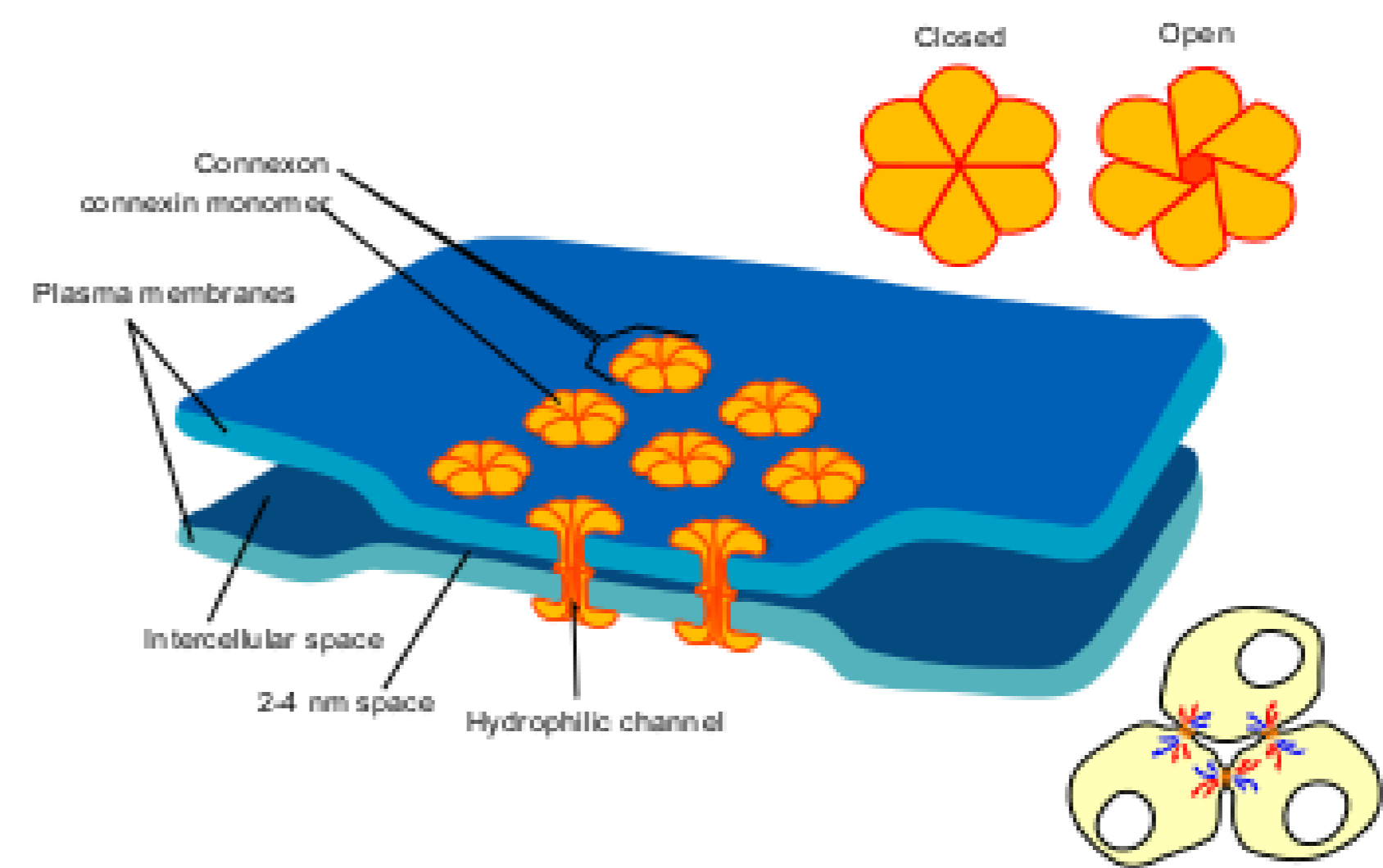

Gap junctions have a different conductivity. The penultimate line of equation (1) can be slightly modified on a Gap Junction to take this into account. If we denote Γ_g the set of all gap junctions, it would become

$$-\sigma_{i1} \nabla u_{i1} \cdot n_{i1} = \sigma_g I_g \partial_t v_g + I_g I_{\text{ion}}(v) \quad \text{on } \Gamma_g,$$

σ_g being the conductivity of the gap junction, $v_g = u_{i1} - u_{i2}$ the voltage between the two cells at the gap junction, I_g a one or zero operator modelling the open/closed state of the gap junction.

Conclusion and perspectives

Conclusion

- We have designed a basic model and proved existence of a unique solution;
- The hypotheses we made in this regard are consistent with the physics of the problem.

Perspectives

- Model enhancement with gap junctions and specificities of ionic channel (gating variables);
- Ongoing work on simulation, using a homemade framework;
- Enhance the model regarding what happens inside the cells;
- Discuss on the dimensions, especially the thickness of the membrane vs. the spacing between cells.