



**HAL**  
open science

## Fixed-time stabilization and consensus of nonholonomic systems

Michael Defoort, Guillaume Demesure, Zongyu Zuo, Andrey Polyakov,  
Mohamed Djemai

► **To cite this version:**

Michael Defoort, Guillaume Demesure, Zongyu Zuo, Andrey Polyakov, Mohamed Djemai. Fixed-time stabilization and consensus of nonholonomic systems. IET Control Theory and Applications, 2016, 10.1049/iet-cta.2016.0094 . hal-01405104

**HAL Id: hal-01405104**

**<https://inria.hal.science/hal-01405104v1>**

Submitted on 29 Nov 2016

**HAL** is a multi-disciplinary open access archive for the deposit and dissemination of scientific research documents, whether they are published or not. The documents may come from teaching and research institutions in France or abroad, or from public or private research centers.

L'archive ouverte pluridisciplinaire **HAL**, est destinée au dépôt et à la diffusion de documents scientifiques de niveau recherche, publiés ou non, émanant des établissements d'enseignement et de recherche français ou étrangers, des laboratoires publics ou privés.

# Fixed-time stabilization and consensus of nonholonomic systems

Michael Defoort<sup>a,\*</sup>, Guillaume Demesure<sup>a</sup>, Zongyu Zuo<sup>b</sup>, Andrey Polyakov<sup>c</sup>, Mohamed Djemai<sup>a</sup>

<sup>a</sup>LAMIH, CNRS UMR 8201, University of Valenciennes and Hainaut-Cambresis, Le Mont Houy, 59313 Valenciennes Cedex 9, France

<sup>b</sup>Seventh Research Division, and Science and Technology on Aircraft Control Laboratory, Beihang University, Beijing 100191, China

<sup>c</sup>NON-A team, Inria Lille-Nord Europe, 59300 Lille, France

---

## Abstract

This paper focuses on the design of fixed-time consensus for multiple unicycle-type mobile agents. A distributed switched strategy, based on local information, is proposed to solve the leader-follower consensus problem for multiple nonholonomic agents in chained form. The switching times and the prescribed convergence time are explicitly given regardless of the initial conditions. Simulation results highlight the efficiency of the proposed method.

*Keywords:* Consensus, Nonholonomic system, Fixed-time convergence, Multi-agent system

---

## 1. Introduction

Control of nonholonomic systems, i.e. systems subject to constraints that are often expressed in terms of nonintegrable linear velocity relationships, has been an active research topic (see [1] for an extended survey). It is because the control of nonholonomic systems arises in numerous applications (ground mobile robots [2], underwater vehicles [3], surface ships [4], etc.), and also because those systems fail necessary conditions for the existence of smooth static state feedback that guarantees asymptotic stability of the equilibrium (see [5]). Thus, it is a challenging nonlinear control problem. Works on the stabilization problem for such systems have mainly focused on the design of time-varying or discontinuous feedback controllers. Thus, many control strategies such as smooth time-varying feedbacks [6], sinusoidal and polynomial controls [7], controls based on backstepping approaches [8], and nonsmooth feedbacks [9, 10, 11] have been investigated. However, most of the mentioned controllers only deal with a single agent.

The research effort in multi-agent systems (MAS) relies on the fact that multiple agents may perform a mission more efficiently than a single one, may reduce sensibility to possible agent fault and provide high flexibility during the task execution. During the last two decades, cooperative control of MAS has attracted much attention due to its broad range of applications in many areas, e.g. flocking [12], rendezvous [13], distributed estimation [14], formation control [15, 16], containment control [17], etc.

Among them, the consensus problem, whose objective is to design distributed control policies that enable agents to reach an agreement regarding a certain quantity of interest by relying on neighbors' information [18], has received considerable attention. It has been deeply studied for single integrator MAS [19], second-order MAS [20, 21, 22] and general linear MAS [23]. However, many physical systems are inherently nonlinear. Recently, some works consider the consensus problem for MAS with nonlinear dynamics, while assuming that these nonlinearities are continuously differentiable [24] or globally Lipschitz [25]. However, in practice, the dynamics of robots, UAVs or manipulators are generally with strong nonlinearities which cannot be modeled using continuously differentiable or globally Lipschitz functions. There are a few papers that deal with the consensus problem for nonholonomic systems [26, 27, 28]. Distributed consensus algorithms were proposed for multiple nonholonomic agents in chained form with the aid of backstepping techniques, properties of Laplacian matrix [26, 27], and input-to-state stability theory [28]. One could note that these consensus protocols only achieve asymptotical convergence.

In the study of consensus problem, the convergence rate has been an important topic. Indeed, this important performance index is of high interest to study the effectiveness of a consensus protocol in the context of MAS [29].

---

\*Corresponding author. Email address: michael.defoort@univ-valenciennes.fr

Most of the existing consensus algorithms focus on asymptotic convergence, where the settling time is infinite. However, many applications require a high speed convergence generally characterized by a finite-time control strategy. Moreover, finite-time control allows some advantageous properties such as good accuracy, good disturbance rejection and good robustness against uncertainties. The finite-time consensus problem for MAS has been studied for single integrator [29, 30], double integrator [31, 32] and inherent Lipschitz nonlinear dynamics [33]. Nevertheless, there is almost no work which solves the finite-time consensus problem for nonholonomic systems. In [34], distributed finite-time observers were designed for each follower to estimate the state of the leader. It is worthy of noting that, for the above-mentioned works, the explicit expressions for the bound of the settling time depend on the initial states of agents. Therefore, the knowledge of these initial conditions usually prevent us from the estimation of the settling time using distributed architectures.

A new approach, called fixed-time stability has been recently proposed to define algorithms which guarantee that the settling time is upper bounded regardless to the initial conditions [35]. This concept is promising since one can design a controller such that some control performances are obtained in a given time and independently of initial conditions. It has been applied to single integrator MAS [36, 37] and double integrator MAS [38]. Motivated by these works, in this paper, a fixed-time consensus protocol is proposed for nonholonomic MAS. The main contribution of this paper is twofold: (i) a switched strategy is introduced into the protocol to solve the consensus for multiple nonholonomic agents in chained form; (ii) an explicit estimation of the settling time is provided regardless of the initial conditions. To the best of our knowledge, no results on fixed-time consensus with assignable settling time for nonholonomic MAS are available till now.

This paper is organized as follows. Section 2 is devoted to the formulation of the consensus problem for non-holonomic MAS. Section 3 presents the distributed consensus protocol, based on local information, to ensure the convergence of the tracking errors in finite time. Some conditions are derived to select the controller gains in order to obtain a prescribed convergence time regardless of the initial conditions. In Section 4, some examples are discussed to show the effectiveness of the proposed scheme.

*Notations:* We denote the transpose of a matrix  $M$  by  $M^T$  and  $\text{eig}(M)$  its eigenvalues.  $\lambda_{\min}(M)$  (resp.  $\lambda_{\max}(M)$ ) are the smallest and the largest eigenvalues of  $M$ .

For a square symmetric matrix  $P \in \mathbb{R}^{N \times N}$ ,  $P > \mathbf{0}$  (resp.  $P < \mathbf{0}$ ) indicates that  $P$  is positive (resp. negative) definite.

Let  $\text{diag}(a_1, a_2, \dots, a_{N-1}, a_N)$  the diagonal matrix  $\begin{pmatrix} a_1 & 0 & \dots & 0 \\ 0 & \ddots & \ddots & \vdots \\ \vdots & \ddots & \ddots & 0 \\ 0 & \dots & 0 & a_N \end{pmatrix} \in \mathbb{R}^{N \times N}$ . For a given vector  $x \in \mathbb{R}^N$ ,  $|x|$

(resp.  $\|x\|$ ) denotes the 1-norm (resp. 2-norm) of  $x$ .

For  $x = (x_1, \dots, x_N)^T \in \mathbb{R}^N$  and  $b \geq 0$ , let us define  $|x|^b = (\text{sign}(x_1)|x_1|^b, \dots, \text{sign}(x_N)|x_N|^b)^T$ .

## 2. Preliminaries and problem formulation

First, let us recall some basic notions on graph theory and some useful lemmas. Then, the control objective will be introduced.

### 2.1. Graph theory notions

To solve the coordination problem and model exchanged information between agents, graph theory is briefly recalled hereafter.

Let us consider a group of  $N$  nonholonomic systems. The communication topology among all agents is fixed and is represented by an undirected graph  $\mathcal{G}$  which consists of a nonempty set of nodes  $\mathcal{V} = \{1, 2, \dots, N\}$  and a set of edges  $\mathcal{E} \subset \mathcal{V} \times \mathcal{V}$ . Here, each node in  $\mathcal{V}$  corresponds to an agent  $i$ , and each edge  $(i, j) \in \mathcal{E}$  in the undirected graph corresponds to an information link between agent  $i$  and agent  $j$ . The topology of graph  $\mathcal{G}$  is represented by the weighted adjacency matrix  $A = (a_{ij}) \in \mathbb{R}^{N \times N}$  given by  $a_{ij} > 0$  if  $(j, i) \in \mathcal{E}$  and  $a_{ij} = 0$ , otherwise. The Laplacian matrix of  $\mathcal{G}$  is defined as  $L = (l_{ij}) \in \mathbb{R}^{N \times N}$  with  $l_{ii} = \sum_{j=1, j \neq i}^N a_{ij}$  and  $l_{ij} = -a_{ij}$  for  $i \neq j$ . For an undirected graph,  $L$  is symmetric positive semi-definite. Graph  $\mathcal{G}$  is connected if and only if its Laplacian matrix has a simple zero eigenvalue with associated eigenvector  $\mathbf{1}_N = (1, 1, \dots, 1)^T \in \mathbb{R}^N$  [18].

## 2.2. Fixed-time stability

Let us consider the following system

$$\begin{cases} \dot{x}(t) & \in F(t, x(t)) \\ x(0) & = x_0 \end{cases} \quad (1)$$

where  $x \in \mathbb{R}^n$  is the state,  $F : \mathbb{R}^+ \times \mathbb{R}^n \rightarrow \mathbb{R}^n$  be an upper semicontinuous convex-valued mapping, such that the set  $F(t, x)$  is non-empty for any  $(t, x) \in \mathbb{R}^+ \times \mathbb{R}^n$  and  $F(t, 0) = 0$  for  $t > 0$ . The solutions of (1) are understood in the Filippov sense [39].

**Definition 1.** [40] *The origin of system (1) is a globally finite-time equilibrium if there is a function  $T : \mathbb{R}^n \mapsto \mathbb{R}^+$  such that for all  $x_0 \in \mathbb{R}^n$ , the solution  $x(t, x_0)$  of system (1) is defined and  $x(t, x_0) \in \mathbb{R}^n$  for  $t \in [0, T(x_0))$  and  $\lim_{t \rightarrow T(x_0)} x(t, x_0) = 0$ .  $T(x_0)$  is called the settling time function.*

**Definition 2.** [35] *The origin of system (1) is a globally fixed-time equilibrium if it is globally finite-time stable and the settling time function  $T(x_0)$  is bounded by some positive number  $T_{\max} > 0$ , i.e.  $T(x_0) \leq T_{\max}$  for  $\forall x_0 \in \mathbb{R}^n$ .*

The fixed-time stabilization at the origin can be demonstrated on the simplest scalar control system  $\dot{x}(t) = u(t)$ , where  $x \in \mathbb{R}$  is the state and  $u \in \mathbb{R}$  is the control input. If the so-called negative relay feedback  $u = -\text{sign}(x)$  is applied, then the closed-loop system is finite-time stable with the settling-time  $T(x_0) = |x_0|$ . It is worthy of noting that the settling time depends on the initial conditions and is unbounded. The fixed-time control algorithm [35] has the form  $u = -(|x|^2 + 1) \text{sign}(x)$ . It guarantees finite convergence time independently of the initial conditions, namely,  $T(x_0) \leq \frac{\pi}{2}$ .

**Lemma 1.** [35] *Assume that there exists a continuously differentiable positive definite and radially unbounded function  $V : \mathbb{R}^n \rightarrow \mathbb{R}^+$  such that*

$$\sup_{t > 0, y \in F(t, x)} \frac{\partial V(x)}{\partial x} y \leq -aV^p(x) - bV^q(x) \quad \text{for } x \neq 0$$

with  $a, b > 0$ ,  $p < 1$  and  $q > 1$ . Then, the origin of the differential inclusion (1) is globally fixed-time stable with the settling time estimate

$$T(x_0) \leq T_{\max} = \frac{1}{a(1-p)} + \frac{1}{b(q-1)}.$$

More strong result is provided by the following lemma that refines the previous lemma.

**Lemma 2.** [37] *Assume that there exists a continuously differentiable positive definite and radially unbounded function  $V : \mathbb{R}^n \rightarrow \mathbb{R}^+$  such that*

$$\sup_{t > 0, y \in F(t, x)} \frac{\partial V(x)}{\partial x} y \leq -aV^p(x) - bV^q(x) \quad \text{for } x \neq 0$$

with  $a, b > 0$ ,  $p = 1 - \frac{1}{\mu}$ ,  $q = 1 + \frac{1}{\mu}$  and  $\mu \geq 1$ . Then, the origin of the differential inclusion (1) is globally fixed-time stable with the settling time estimate

$$T(x_0) \leq T_{\max} = \frac{\pi\mu}{2\sqrt{ab}}.$$

## 2.3. Problem formulation

Each agent  $n$  ( $n \in \{1, \dots, N\}$ ), shown in Fig. 1, is of unicycle-type. The center of mass is at the geometric center  $C_n$  of the body. It has two driving wheels fixed to the axis which passes through  $C_n$  and one passive centered orientable wheel. The two fixed wheels separated by  $2\rho_n$ , are independently controlled by two actuators (DC motors) and the passive wheel prevents the robot from tipping over as it moves on a plane. In this paper, we assume that the motion of the passive wheel can be ignored in the dynamics of the agent. The center of mass  $C_n$ , whose coordinates are  $(x_n, y_n)$ ,

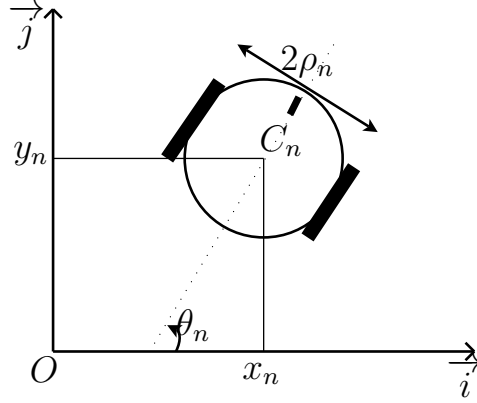

Figure 1: Unicycle-type mobile robot.

is located at the intersection of a straight line passing through the middle of the vehicle and the axis of the two driving wheels. The configuration of the robot can be described by:

$$q_n(t) = (x_n(t), y_n(t), \theta_n(t))^T$$

where  $\theta_n(t)$  is its orientation in the global frame.

In this paper, the kinematics of wheeled-mobile robot is shown under the nonholonomic constraints. The pure rolling and nonslipping nonholonomic conditions are described by:

$$\psi^T(q_n)\dot{q}_n = 0 \quad \text{with} \quad \psi^T(q_n) = \begin{pmatrix} -\sin \theta_n & \cos \theta_n & 0 \end{pmatrix}$$

The kinematic equations can be written as follows:

$$\dot{q}_n(t) = f(q_n(t), u_n(t)) \quad (2)$$

where vector field  $f: \mathbb{R}^3 \times \mathbb{R}^2 \rightarrow \mathbb{R}^3$  and control inputs  $u_n$  are defined as:

$$\begin{cases} f(q_n(t), u_n(t)) &= \begin{pmatrix} \cos \theta_n(t) & 0 \\ \sin \theta_n(t) & 0 \\ 0 & 1 \end{pmatrix} u_n(t) \\ u_n(t) &= (v_n(t), w_n(t))^T \end{cases}$$

$v_n(t)$  and  $w_n(t)$  are the linear and angular velocities, respectively.

A leader, which could be virtual, is assumed to be fixed and has the following configuration  $q_0 = (x_0(t), y_0(t), \theta_0(t))^T$ . It is assumed that the state of the leader is available to a portion of the  $N$  agents. Let us consider the group of  $N + 1$  agents which includes the  $N$  nonholonomic systems and the virtual leader, denoted by 0. The communication topology among the  $N + 1$  agents is fixed and is represented by the graph  $\mathcal{G}$ . The topology of  $\mathcal{G}$  is described by the weighted matrix  $H = L + D \in \mathbb{R}^{N \times N}$  where  $D = \text{diag}(a_{10}, \dots, a_{N0})$  with  $a_{i0} > 0$  if the desired state is available to agent  $i$  and with  $a_{i0} = 0$  otherwise.

The objective of this paper is to design a distributed control protocol  $u_n$  ( $n = 1, \dots, N$ ), based on available local information, such that the leader-follower consensus problem is solved in a prescribed time  $T_{max}$ , i.e.

$$q_n(t) = q_0, \quad \forall t \geq T_{max}, \quad \forall n \in \{1, \dots, N\} \quad (3)$$

In order to solve problem (3), the following assumption is needed.

**Assumption 1.** It is assumed that graph  $\mathcal{G}$  is connected and at least one  $a_{i0} > 0$ .

Before designing the consensus protocol, let us consider the classical transformation:

$$\begin{cases} \xi_{n1} &= \theta_n \\ \xi_{n2} &= x_n \sin \theta_n - y_n \cos \theta_n \\ \xi_{n3} &= x_n \cos \theta_n + y_n \sin \theta_n \\ v_{n1} &= w_n \\ v_{n2} &= v_n - \xi_{n2} w_n \end{cases}, \quad n \in \{1, \dots, N\} \quad (4)$$

Using (4), system (2) can be written in chained form as follows:

$$\begin{cases} \dot{\xi}_{n1} &= v_{n1} \\ \dot{\xi}_{n2} &= \xi_{n3} v_{n1} \\ \dot{\xi}_{n3} &= v_{n2} \end{cases}, \quad n \in \{1, \dots, N\} \quad (5)$$

The control objective (3) becomes to design a distributed control protocol  $v_n = (v_{n1}, v_{n2})^T$  ( $n = 1, \dots, N$ ) using information of the neighboring agents such that the state  $\xi_n = (\xi_{n1}, \xi_{n2}, \xi_{n3})^T \in \mathbb{R}^3$  of subsystems (5) tracks, in a prescribed time  $T_{max}$ , the state  $\xi_0 = (\xi_{01}, \xi_{02}, \xi_{03})^T \in \mathbb{R}^3$  of the leader, defined as

$$\begin{cases} \xi_{01} &= \theta_0 \\ \xi_{02} &= x_0 \sin \theta_0 - y_0 \cos \theta_0 \\ \xi_{03} &= x_0 \cos \theta_0 + y_0 \sin \theta_0 \end{cases}$$

### 3. Fixed-time control protocol design

To solve the leader-follower consensus problem, the distributed control protocol is divided into two steps:

Step1 Using information of the neighboring agents, the state  $\xi_n$  of subsystems (5) tracks, in a prescribed time  $T_{max1}$ , the desired state  $\xi_0^d = (\xi_{01}^d, \xi_{02}^d, \xi_{03}^d)^T \in \mathbb{R}^3$ . This desired state is computed from  $\xi_0$  and satisfies the following conditions:

$$\begin{cases} \xi_{03}^d &= 0 \\ \xi_{02}^d &= x_0^d \sin \theta_0 - y_0^d \cos \theta_0 \end{cases} \quad (6)$$

with

$$\begin{cases} x_0^d &= x_0 \sin^2 \theta_0 - y_0 \cos \theta_0 \sin \theta_0 \\ y_0^d &= y_0 \cos^2 \theta_0 - x_0 \cos \theta_0 \sin \theta_0 \end{cases} \quad (7)$$

One could note that (6) means that the point  $(x_0^d, y_0^d)$  is defined as  $\xi_{03}^d = x_0^d \cos \theta_0 - y_0^d \sin \theta_0 = 0$  and belongs to the line passes through the point  $(x^d, y^d)$  with slope  $\tan \theta_0$ .

To achieve Step1, the dynamics of the  $n$ -th agent are divided into two subsystems: a single integrator dynamics and a second-order subsystem, i.e.

$$\begin{aligned} (\Sigma_1) \quad \dot{\xi}_{n1} &= v_{n1} \\ (\Sigma_2) \quad \begin{cases} \dot{\xi}_{n2} &= \xi_{n3} v_{n1} \\ \dot{\xi}_{n3} &= v_{n2} \end{cases} \end{aligned}$$

Two sub-steps will be required:

Step1.i Setting  $v_{n1} = 1$ , subsystem  $\Sigma_2$  can be written as:

$$\begin{cases} \dot{\xi}_{n2} &= \xi_{n3} \\ \dot{\xi}_{n3} &= v_{n2} \end{cases} \quad (8)$$

The control input  $v_{n2}$  will be designed, based on available local information, using nonsingular terminal sliding mode control, to guarantee

$$\begin{cases} \xi_{n2}(t) &= \xi_{02}^d \\ \xi_{n3}(t) &= 0 \end{cases}, \quad \forall t \geq T_{sw1}, \quad \forall n \in \{1, \dots, N\} \quad (9)$$

Step1.ii For  $t > T_{sw1}$ , equation (9) holds. The control input  $v_{n2}$  is designed to keep  $\xi_{n3}(t) = 0$ . From (5), it implies that  $\dot{\xi}_{n2} = 0$ . Hence, the states  $\xi_{n2}$  and  $\xi_{n3}$  remain constant whatever the control input  $v_{n1}$  is. A fixed-time consensus protocol will be designed, based on available local information, to guarantee

$$\begin{aligned}\xi_{n1}(t) &= \xi_{01} \\ \xi_{n2}(t) &= \xi_{02}^d, \quad \forall t \geq T_{max1}, \quad \forall n \in \{1, \dots, N\} \\ \xi_{n3}(t) &= 0\end{aligned}\quad (10)$$

Step2 For  $t > T_{max1}$ , using information of the neighboring agents, the state  $\xi_n$  of subsystems (5) tracks, in a prescribed time  $T_{max2}$ , the desired state  $\xi_0$ . One could note that for  $t > T_{max}$ , subsystems (5) could be reduced to a single integrator because of choice of  $q_0^d = (x_0^d, y_0^d, \theta_0)^T$ .

The principle of the proposed scheme is depicted in Fig. 2.

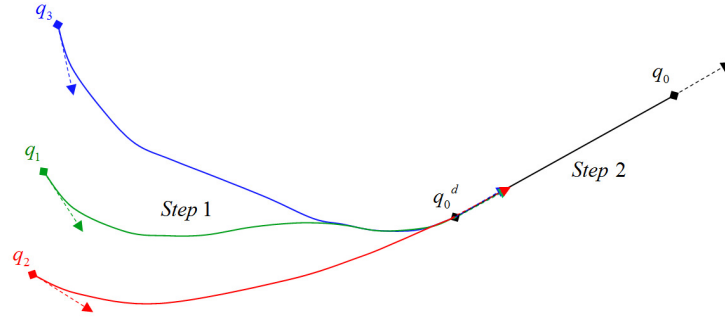

Figure 2: Principle of the distributed control protocol.

**Theorem 1.** Suppose that Assumption 1 is fulfilled. The leader-follower consensus problem is solved in a prescribed time  $T_{max}$  under the distributed control protocol  $v_n$  ( $n = 1 \dots, N$ ):

$$\begin{aligned}v_{n1} &= \begin{cases} 1, & \text{if } t \leq T_{sw1} \\ -k_5 \left[ \tilde{\xi}_{n1} \right]^2 - k_6 \text{sign}(\tilde{\xi}_{n1}), & \text{if } t > T_{sw1} \end{cases} \\ v_{n2} &= \begin{cases} v_{n2}^{tsm}, & \text{if } t \leq T_{sw1} \\ -k_7 \text{sign}(\tilde{\xi}_{n3}), & \text{if } T_{sw1} < t \leq T_{sw2} \\ -\xi_{n2} v_{n1} - k_8 \left[ \tilde{x}_n \right]^2 - k_9 \text{sign}(\tilde{x}_n), & \text{if } t > T_{sw2} \end{cases}\end{aligned}$$

where  $v_{n2}^{tsm}$  is the nonsingular terminal sliding mode control defined hereafter. The switching times ( $T_{sw1}$  and  $T_{sw2}$ ) and the prescribed time ( $T_{max}$ ) does not depend on the initial conditions of the systems and are explicitly given in the proof. Control parameters  $k_5, k_6, k_7, k_8$  and  $k_9$  are positive definite constants.

The disagreements  $\tilde{\xi}_1 = (\tilde{\xi}_{11}, \tilde{\xi}_{21}, \dots, \tilde{\xi}_{N1})^T$ ,  $\tilde{\xi}_2 = (\tilde{\xi}_{12}, \tilde{\xi}_{22}, \dots, \tilde{\xi}_{N2})^T$ ,  $\tilde{\xi}_3 = (\tilde{\xi}_{13}, \tilde{\xi}_{23}, \dots, \tilde{\xi}_{N3})^T$  and  $\tilde{x} = (\tilde{x}_1, \tilde{x}_2, \dots, \tilde{x}_N)^T$  are defined such that  $\forall n = 1, \dots, N$

$$\begin{aligned}\tilde{\xi}_{n1} &= -\left( \sum_{j=1}^N a_{nj} (\xi_{j1} - \xi_{n1}) + a_{n0} (\xi_{01} - \xi_{n1}) \right) \\ \tilde{\xi}_{n2} &= -\left( \sum_{j=1}^N a_{nj} (\xi_{j2} - \xi_{n2}) + a_{n0} (\xi_{02}^d - \xi_{n2}) \right) \\ \tilde{\xi}_{n3} &= -\left( \sum_{j=1}^N a_{nj} (\xi_{j3} - \xi_{n3}) - a_{n0} \xi_{n3} \right) \\ \tilde{x}_n &= -\left( \sum_{j=1}^N a_{nj} (\bar{x}_j - \bar{x}_n) + a_{n0} (\bar{x}_0 - \bar{x}_n) \right)\end{aligned}\quad (11)$$

with

$$\begin{cases} \bar{x}_n &= \cos(\theta_n)x_n + \sin(\theta_n)y_n \\ \bar{x}_0 &= \cos(\theta_0)x_0 + \sin(\theta_0)y_0 \end{cases}\quad (12)$$

**Proof 1.** The proof is divided into three steps.

- For  $0 \leq t \leq T_{sw1}$ , since  $v_{n1} = 1$ , subsystem  $\Sigma_2$  becomes a double integrator. The time derivative of the disagreements  $\tilde{\xi}_2$  and  $\tilde{\xi}_3$  are given by

$$\begin{aligned}\dot{\tilde{\xi}}_2 &= \tilde{\xi}_3 \\ \dot{\tilde{\xi}}_3 &= H\mathbf{v}_2\end{aligned}\quad (13)$$

with  $\mathbf{v}_2 = (v_{12}^{ism}, v_{22}^{ism}, \dots, v_{N2}^{ism})^T$ . Motivated by [38], one can derive the following fixed time consensus protocol based on nonsingular terminal sliding mode control:  $\forall n = 1, \dots, N$

$$\begin{aligned}v_{n2}^{ism} &= \left(\sum_{j=1}^N a_{ij}\right)^{-1} \frac{1}{\alpha(\tilde{\xi}_{n2})} \left(k_1(q-p) \left|\tilde{\xi}_{n2}\right|^{q-p-1} \left(\alpha(\tilde{\xi}_{n2}) \tilde{\xi}_{n3}\right)^2 - p\alpha(\tilde{\xi}_{n2})^{1-\frac{1}{p}} \left|\tilde{\xi}_{n3}\right|^{2-\frac{1}{p}}\right) \\ &\quad - \left(\sum_{j=1}^N a_{ij}\right)^{-1} \frac{1}{\alpha(\tilde{\xi}_{n2})} \left(p\alpha(\tilde{\xi}_{n2})^{-\frac{1}{p}} \left(\left|\tilde{\xi}_{n3}\right|^{1-\frac{1}{p}} \beta\left(\left|\tilde{\xi}_{n3}\right|^{\frac{1}{p}-1}\right) \left(k_3 |s_n|^{1+\frac{2}{\mu}} + k_4 |s_n|^{1-\frac{2}{\mu}}\right)\right) + \sum_{j=1}^N a_{nj} v_{j2}\right)\end{aligned}\quad (14)$$

where  $\alpha(\cdot) : \mathbb{R} \rightarrow \mathbb{R}^+$  is a scalar positive function, given by:

$$\alpha(x) = \frac{1}{k_1|x|^{q-p} + k_2}\quad (15)$$

and  $\beta(\cdot) : \mathbb{R}^+ \rightarrow [0, 1]$  is a scalar positive function, given by:

$$\beta(x) = \begin{cases} \sin\left(\frac{\pi x}{\tau}\right), & \text{if } x \leq \tau \\ 1, & \text{else} \end{cases}\quad (16)$$

$\tau$  is an arbitrarily small positive constant. The control parameters  $\frac{1}{2} < p < 1$ ,  $q > 1 + p$  and  $\mu > 1$  are positive constants. The nonsingular terminal sliding surface is defined as:

$$s_n = \tilde{\xi}_{n2} + \left[\alpha(\tilde{\xi}_{n2}) \tilde{\xi}_{n3}\right]^{\frac{1}{p}}\quad (17)$$

Differentiating (17) with respect to time, one gets:

$$\dot{s}_n = -\beta\left(\left|\tilde{\xi}_{n3}\right|^{\frac{1}{p}-1}\right) \left(k_3 |s_n|^{1+\frac{2}{\mu}} + k_4 |s_n|^{1-\frac{2}{\mu}}\right)$$

Let us consider the Lyapunov function  $V_1 = (1/2) \sum_{n=1}^N s_n^2$ . Its time derivative along the system trajectories is:

$$\begin{aligned}\dot{V}_1 &= -\sum_{n=1}^N \beta\left(\left|\tilde{\xi}_{n3}\right|^{\frac{1}{p}-1}\right) \left(k_3 |s_n|^{2+\frac{2}{\mu}} + k_4 |s_n|^{2-\frac{2}{\mu}}\right) \\ &\leq -\beta_m \left[k_3 N^{-\frac{1}{\mu}} (2V_1)^{1+\frac{1}{\mu}} + k_4 (2V_1)^{1-\frac{1}{\mu}}\right]\end{aligned}$$

with  $\beta_m = \min_{n=1, \dots, N} \left\{ \beta\left(\left|\tilde{\xi}_{n3}\right|^{\frac{1}{p}-1}\right) \right\}$ . Let us note that  $\beta_m > 0$  if  $\tilde{\xi}_{n3} \neq 0$  for all  $n = 1, \dots, N$  and  $\beta_m = 1$  if  $\min_{n=1, \dots, N} \left\{ \left|\tilde{\xi}_{n3}\right| \right\} > \tau^{\frac{p}{1-p}}$ . Applying Lemma 2 and Theorem 5 in [38], one can obtain the fixed-time stabilization of the sliding surface  $s_n$ ,  $\forall n = 1, \dots, N$ . For small value of  $\tau$ , the settling time is bounded by  $T_1$ , given by:

$$T_1 = \frac{\pi \gamma N^{\frac{1}{\mu}}}{4\sqrt{k_3 k_4}}$$

Once the sliding surface  $s_n = 0$  is reached (i.e.  $t > T_1$ ), the sliding mode occurs. In sliding mode, the reduced dynamics, obtained from (17) becomes

$$\tilde{\xi}_{n3} = -k_1 \left[\tilde{\xi}_{n2}\right]^q - k_2 \left[\tilde{\xi}_{n2}\right]^p\quad (18)$$



Let us consider the Lyapunov function  $V_2 = (1/2) \sum_{n=1}^N \tilde{\xi}_{n2}^2$ . Its time derivative along the system trajectories is:

$$\begin{aligned} \dot{V}_2 &= -k_1 \sum_{n=1}^N (\tilde{\xi}_{n2}^2)^{\frac{q+1}{2}} - k_2 \sum_{n=1}^N (\tilde{\xi}_{n2}^2)^{\frac{p+1}{2}} \\ &\leq -k_1 N^{\frac{1-q}{2}} (2V_2)^{\frac{q+1}{2}} - k_2 (2V_2)^{\frac{p+1}{2}} \end{aligned}$$

Applying Lemma 1, one can obtain the fixed-time stabilization of the sliding surface  $\tilde{\xi}_{n2}$ ,  $\forall n = 1, \dots, N$ . The corresponding settling time is bounded by  $T_2$ , given by:

$$T_2 = \frac{1}{k_1 N^{\frac{1-q}{2}} 2^{\frac{q+1}{2}} \frac{q-1}{2}} + \frac{1}{k_2 2^{\frac{p+1}{2}} \frac{1-p}{2}}$$

Hence,  $\tilde{\xi}_2$  converges to zero in a finite time bounded by  $T_{sw1}$ , defined as:

$$T_{sw1} = T_1 + T_2$$

Applying Theorem 4 in [31], it follows that (9) holds.

- For  $T_{sw1} \leq t \leq T_{sw2}$ , the control input  $v_{n2}$  is designed to keep  $\xi_{n3}(t) = 0$ . Let us define  $\hat{\xi}_3 = (\xi_{13}, \xi_{23}, \dots, \xi_{N3})^T$ . Consider the candidate Lyapunov function

$$V_3 = \frac{1}{2} (\hat{\xi}_3)^T H \hat{\xi}_3 \quad (19)$$

$H \succ \mathbf{0}$  since graph  $\mathcal{G}$  is connected and there is at least one  $a_{i0}$  positive. Its time derivative is given by

$$\begin{aligned} \dot{V}_3 &\leq -k_7 \|H \hat{\xi}_3\|_1 \\ \dot{V}_3 &\leq -k_7 \frac{\sqrt{2\lambda_{\min}(H)}}{\sqrt{\lambda_{\max}(H)}} \sqrt{V_3} \end{aligned} \quad (20)$$

Since  $\xi_{n3}(T_{sw1}) = 0$ , one can conclude from (20) that  $\xi_{n3}(t) = 0$  is kept after  $t > T_{sw1}$ . From (5), it implies that  $\tilde{\xi}_{n2}(t) = 0$  for all  $t \in [T_{sw1}, T_{sw2}]$ . Hence, the states  $\xi_{n2}$  and  $\xi_{n3}$  remain constant whatever the control input  $v_{n1}$  is.

Let us define  $\hat{\xi}_1 = (\xi_{11} - \xi_{01}, \xi_{21} - \xi_{01}, \dots, \xi_{N1} - \xi_{01})^T$ . Consider the candidate Lyapunov function

$$V_4 = \frac{1}{2} (\hat{\xi}_1)^T H \hat{\xi}_1 \quad (21)$$

Its time derivative along the system trajectories is given by

$$\begin{aligned} \dot{V}_4 &\leq -k_5 (\hat{\xi}_1)^T H \left[ H \hat{\xi}_1 \right] - k_6 \|H \hat{\xi}_1\|_1 \\ \dot{V}_4 &\leq -k_5 N^{\frac{1}{2}} (2\lambda_{\min}(H))^{\frac{3}{2}} V_4^{\frac{3}{2}} - k_6 \frac{\sqrt{2\lambda_{\min}(H)}}{\sqrt{\lambda_{\max}(H)}} \sqrt{V_4} \end{aligned} \quad (22)$$

Applying Lemma 2, one can obtain the fixed-time stabilization of  $\hat{\xi}_1$ , i.e. (10) holds. The settling time is bounded by  $T_3$ , given by:

$$T_3 = \frac{\pi N^{\frac{1}{4}} \lambda_{\min}(H)^{-\frac{5}{4}} \lambda_{\max}(H)^{\frac{1}{4}}}{2\sqrt{k_5 k_6}}$$

Therefore, the second switching time is

$$T_{sw2} = T_1 + T_2 + T_3$$

It should be highlighted that due to transformation (4), this consensus protocol achieves the convergence of  $\theta_n - \theta_0$  ( $n = 1, \dots, N$ ) toward zero in a finite time bounded by  $T_{sw2}$ . Hence, the last step is to keep  $\theta_n$  at  $\theta_0$  while reaching the consensus in finite time, i.e.

$$\begin{aligned} x_n(t) &= x_0, \\ y_n(t) &= y_0, \end{aligned} \quad \forall t \geq T_{max}, \quad \forall n \in \{1, \dots, N\} \quad (23)$$

- For  $t > T_{sw2}$ , the control input  $v_{n1}$  is designed to keep  $\theta_n - \theta_0$ . Since  $\forall n \in \{1, \dots, N\}$ ,  $\theta_n(T_{sw2}) = \theta_0$ , one can conclude that from (22) that  $\theta_n(t) = \theta_0$  is kept after  $t > T_{sw2}$  whatever the control input  $v_{n2}$  is.

Let us introduce the following transformation:  $\forall n = 1, \dots, N$ ,

$$\begin{cases} \bar{x}_n &= \cos(\theta_0)x_n + \sin(\theta_0)y_n \\ \bar{y}_n &= \cos(\theta_0)y_n - \sin(\theta_0)x_n \end{cases} \quad (24)$$

The dynamics of the transformed state become:

$$\begin{cases} \dot{\bar{x}}_n &= \cos(\theta_n - \theta_0)v_n \\ \dot{\bar{y}}_n &= \sin(\theta_n - \theta_0)v_n \end{cases} \quad (25)$$

Since  $\theta_n(t) = \theta_0$ ,  $\forall t > T_{sw2}$ , (25) reduces to

$$\begin{aligned} \dot{\bar{x}}_n &= v_n \\ &= -k_8 \left[ \tilde{\bar{x}}_n \right]^2 - k_9 \text{sign}(\tilde{\bar{x}}_n) \\ \dot{\bar{y}}_n &= 0 \end{aligned}$$

It should be noted that in this case, (24) is similar to (12). Furthermore, due to equations (4), (6), it follows that

$$\begin{aligned} \bar{y}_n(t) &= \xi_{n2}(t) \\ &= \xi_{02}^d, \quad \forall t \geq T_{sw2}, \quad \forall n \in \{1, \dots, N\} \\ &= x_0^d \sin \theta_0 - y_0^d \cos \theta_0 \end{aligned} \quad (26)$$

Let us define  $\hat{x} = (\bar{x}_1 - \bar{x}_0, \bar{x}_2 - \bar{x}_0, \dots, \bar{x}_N - \bar{x}_0)^T$ . Consider the candidate Lyapunov function

$$V_5 = \frac{1}{2}(\hat{x})^T H \hat{x} \quad (27)$$

Its time derivative along the system trajectories is given by

$$\begin{aligned} \dot{V}_5 &\leq -k_8(\hat{x})^T H [H\hat{x}] - k_9 \|H\hat{x}\|_1 \\ \dot{V}_5 &\leq -k_8 N^{-\frac{1}{2}} (2\lambda_{\min}(H))^{\frac{3}{2}} V_5^{\frac{3}{2}} - k_9 \frac{\sqrt{2\lambda_{\min}(H)}}{\sqrt{\lambda_{\max}(H)}} \sqrt{V_5} \end{aligned} \quad (28)$$

Applying Lemma 2, one can obtain the fixed-time stabilization of  $\hat{x}$ , i.e.

$$\bar{x}_n(t) = \cos(\theta_0)x_0 + \sin(\theta_0)y_0, \quad \forall t \geq T_{sw2}, \quad \forall n \in \{1, \dots, N\} \quad (29)$$

The settling time is bounded by  $T_4$ , given by:

$$T_4 = \frac{\pi N^{\frac{1}{4}} \lambda_{\min}(H)^{-\frac{5}{4}} \lambda_{\max}(H)^{\frac{1}{4}}}{2\sqrt{k_8 k_9}}$$

From (26), (29), one can conclude the leader-follower consensus problem is solved in a prescribed time  $T_{max}$  given by

$$T_{max} = T_1 + T_2 + T_3 + T_4$$

#### 4. Numerical simulations

Let us consider the multi-agent system (2) with  $N = 6$  followers and one virtual leader. The communication topology, given in Fig. 3 is fixed. It is connected and the corresponding matrix  $H$  is given by

$$H = \begin{bmatrix} 2 & -1 & 0 & 0 & 0 & -1 \\ -1 & 3 & -1 & 0 & 0 & 0 \\ 0 & -1 & 3 & -1 & 0 & -1 \\ 0 & 0 & -1 & 1 & 0 & 0 \\ 0 & 0 & 0 & 0 & 2 & -1 \\ -1 & 0 & -1 & 0 & -1 & 3 \end{bmatrix}$$

1	$q_1 = (7, -1, \frac{-7\pi}{4})^T$
2	$q_2 = (-3, -5, \frac{-3\pi}{2})^T$
3	$q_3 = (0, -6, \frac{-4\pi}{3})^T$
4	$q_4 = (-9, 2, \frac{-11\pi}{6})^T$
5	$q_5 = (4, -1, \pi)^T$
6	$q_6 = (1, 4, \frac{-5\pi}{4})^T$

Table 1: Initial state of the robots.

One can see that agents 1, 3, 4 and 6 do not have direct information from the leader. The initial position of the leader is  $q_0 = (6, -4, \frac{\pi}{6})^T$ . Considering transformation (4), the transformed leader state is  $\xi_0 = (\frac{\pi}{6}, 6.46, 3.2)^T$ . The initial states of the agents are given in Tab. 1. The design parameters are  $k_1 = 2, k_2 = 3, k_3 = 2, k_4 = 3, k_5 = 13, k_6 = 1, k_7 = 0.5, k_8 = 13, k_9 = 1, p = \frac{7}{9}, q = \frac{9}{5}, \tau = 0.01$  and  $\mu = 3$ .

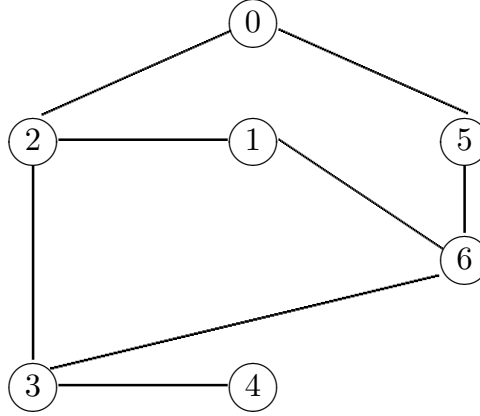

Figure 3: Communication topology.

From Theorem 1, the switching strategy guarantees that the leader-follower consensus problem is solved in a prescribed time  $T_{max}$  given by

$$T_{max} = T_1 + T_2 + T_3 + T_4$$

with

$$\begin{cases} T_1 = 3.94 \\ T_2 = 1.3 \\ T_3 = 2 \\ T_4 = 2 \end{cases}$$

Contrary to existing controllers, here an explicit estimation of the settling time is provided without the a priori knowledge of initial conditions of agents.

Figures 4-6 depict the evolution of the transformed state  $\xi_{n1}, \xi_{n2}$  and  $\xi_{n3}$  for each agent. One can see that using information from the neighboring agents the state  $\xi_n$  tracks in a prescribed time the desired state  $\xi_0^d$ .

## 5. Conclusion

In this paper, the fixed-time consensus tracking problem for multiple unicycle-type mobile agents has been considered. A distributed switched strategy, based on local information, has been proposed to solve the leader-follower

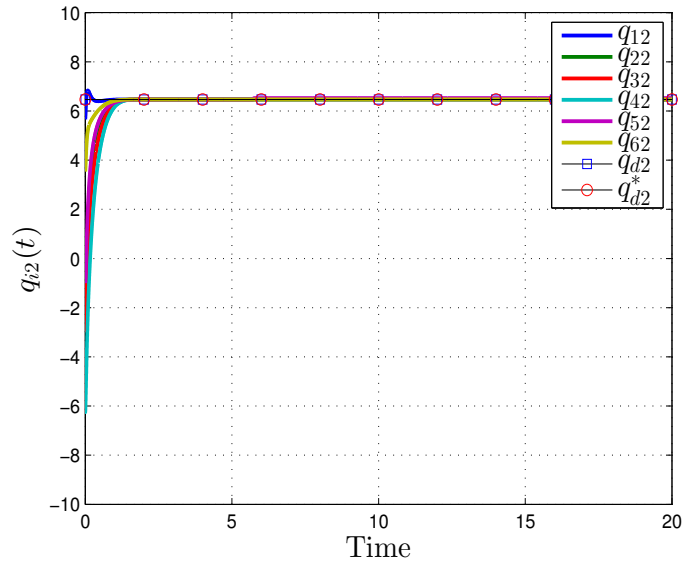

Figure 4: Evolution of  $\xi_{n2}(t)$  for each agent.

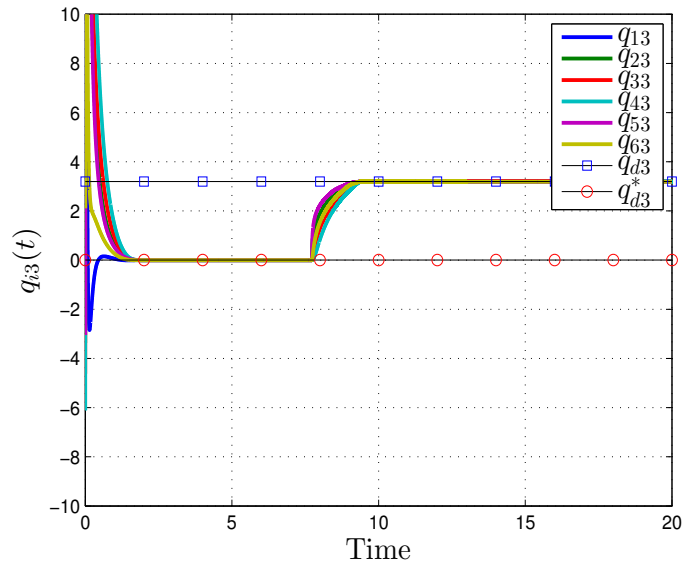

Figure 5: Evolution of  $\xi_{n3}(t)$  for each agent.

consensus problem for multiple nonholonomic agents in chained form. The switching times and the prescribed convergence time have been explicitly given regardless of the initial conditions.

## References

- [1] Kolmanovsky, I., and McClamroch, N. H., *Developments in nonholonomic control problems*, IEEE Control Syst. Mag., 15, pp. 20–36, 1995.

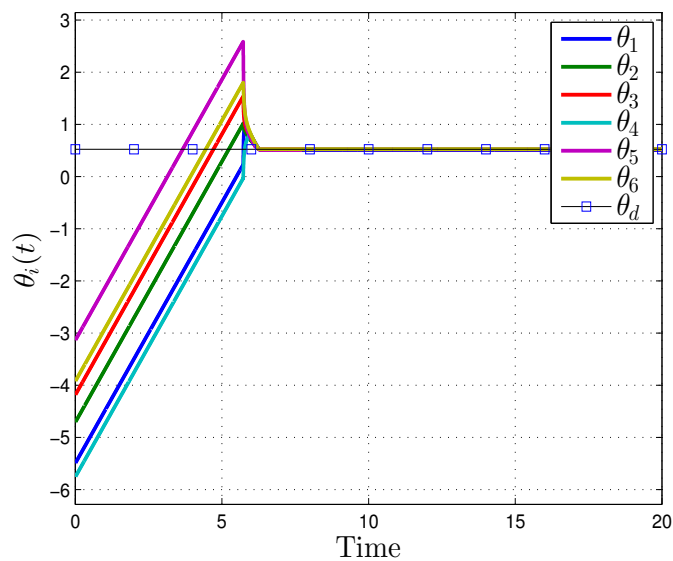

Figure 6: Evolution of the angle  $\theta_n(t) = \xi_{n1}(t)$  for each agent.

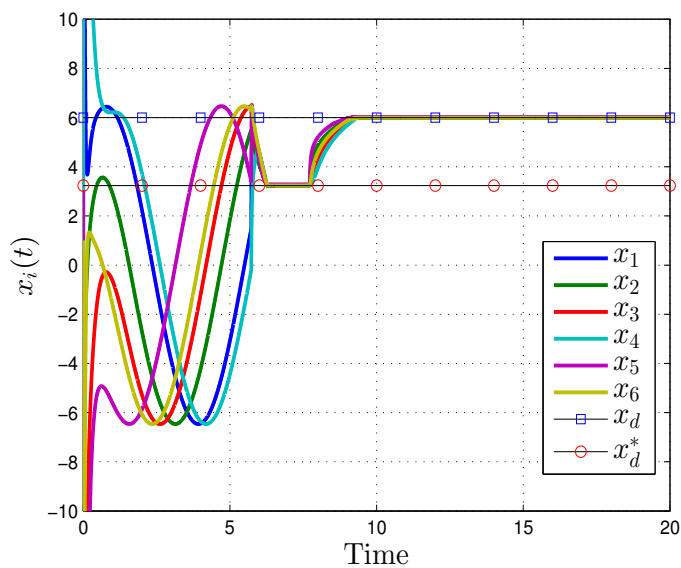

Figure 7: Evolution of  $x_n(t)$  for each agent.

- [2] Defoort M., Palos J., Kokosy A., Floquet T., and Perruquetti W., *Performance-based reactive navigation for nonholonomic mobile robots*, *Robotica*, 27(2), pp. 281-290, 2009.
- [3] Egeland, O., Dalsmo, M., and Soerdalen, O. J., *Feedback control of a nonholonomic underwater vehicle with a constant desired configuration*, *International Journal of Robotics Research*, 15(1), pp. 24-35, 1996.
- [4] Jiang, Z. P., *Global tracking control of underactuated ships by Lyapunov's direct method*, *Automatica*, 38(2), pp. 301-309, 2002.
- [5] Brockett, R. W., *Asymptotic stability and feedback stabilization*, in *Differential Geometric Control Theory*, R. Brockett, R. Millman and H. Sussmann, eds., Boston: Birkhauser, pp. 181-191, 1983.

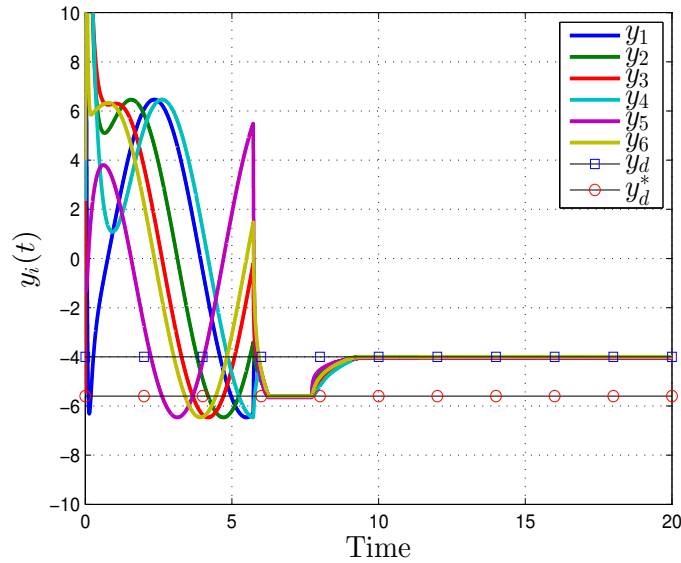

Figure 8: Evolution of  $y_n(t)$  for each agent.

- [6] Pomet, J. B., *Explicit design of time-varying stabilizing control laws for a class of controllable systems without drift*, Systems and Control Letters, 18, pp. 147–158, 1992.
- [7] Murray, R., and Sastry, S., *Nonholonomic Motion Planning: Steering Using Sinusoids*, IEEE Trans. on Automat. Control, 38, pp. 700–716, 1993.
- [8] Xi, Z., Feng, G., Jiang, Z. P., and Cheng, D., *Output feedback exponential stabilization of uncertain chained systems*, Journal of the Franklin Institute, 344(1), pp. 36–57, 2007.
- [9] Astolfi, A., *Discontinuous control of nonholonomic systems*, Systems and Control Letters, 27, (1), pp. 37–45, 1996.
- [10] Defoort M., Floquet T., Perruquetti W., and Drakunov S., *Integral sliding mode control of extended Heisenberg system*, IET Control Theory and Applications, 3(10), pp. 1409–1424, 2009.
- [11] Defoort M., and Djemai M., *A Lyapunov based design of a modified super-twisting algorithm for the heisenberg system*, IMA Journal of Mathematical Control and Information, 30 (2), pp. 185–204, 2013.
- [12] Olfati-Saber, R., *Flocking for Multi-Agent Dynamic Systems: Algorithms and Theory*, IEEE Trans. Aut. Cont., 51(3), pp. 410–420, 2006.
- [13] Su, H., and Chen, G., *Rendezvous of Multiple Mobile Agents with Preserved Network Connectivity*, Syst. Control Lett., 59(5), pp. 313–322, 2010.
- [14] Li, W., Jia, Y., and Du, J., *Distributed Kalman consensus filter with intermittent observations*, Journal of the Franklin Institute, 2015.
- [15] Defoort, M., Floquet, T., Kökösy, K., Perruquetti, W., *Sliding Mode Formation Control for Cooperative Autonomous Mobile Robots*, IEEE Trans. Ind. Electron., 2008, 55(11), pp. 3944–3953.
- [16] Ghommam, J., Mehrjerdi, H., Mnif, F., and Saad, M., *Cascade design for formation control of nonholonomic systems in chained form*. Journal of the Franklin Institute, 348(6), pp. 973–998, 2011.
- [17] Ma, L., Wang, S., Min, H., Liao, S., and Liu, Y., *Distributed finite-time attitude containment control of multi-rigid-body systems*. Journal of the Franklin Institute, 352(5), pp. 2187–2203, 2015.
- [18] Ren, W., and Beard, R., *Consensus Seeking in Multiagent Systems under Dynamically Changing Interaction Topologies*, IEEE Trans. Aut. Cont., 50, pp. 655–661, 2005.
- [19] Ren, W., and Beard, R., *Consensus seeking in multiagent systems under dynamically changing interaction topologies*, IEEE Transactions on Automatic Control, 50(5), pp. 655–661, 2007.
- [20] Ren, W. *On Consensus Algorithms for Double-integrator Dynamics*, IEEE Transactions on Automatic Control, 53(6), pp. 1503–1509, 2008.
- [21] Hu, G., *Robust consensus tracking of a class of second-order multi-agent dynamic systems*, Systems and Control Letters, 61(1), 134–142, 2012.
- [22] Djaidja, S., Wu, Q., and Fang, H., *Consensus of double-integrator multi-agent systems without relative state derivatives under communication noises and directed topologies*. Journal of the Franklin Institute, 352(3), pp. 897–912, 2015.
- [23] Li, Z., Wen, G., Duan, Z., and Ren, W., *Designing fully distributed consensus protocols for linear multi-agent systems with directed graphs*, IEEE Transactions on Automatic Control, 60(4), pp. 1152–1157, 2015.
- [24] Li, H., Liao, X., and Huang, T., *Second-order locally dynamical consensus of multiagent systems with arbitrarily fast switching directed topologies*, IEEE Transactions on Systems, Man, and Cybernetics: Systems, 43(6), pp. 1343–1353, 2013.
- [25] Defoort M., Di gennaro S., and Djemai M., *Self-Triggered Control for Multi-Agent Systems with unknown nonlinear inherent dynamics*, IET Control Theory and Applications, 8(18), pp. 2266–2275, 2014.

- [26] Dong W., and J. A. Farrell, *Cooperative control of multiple nonholonomic mobile agents*, IEEE Transactions on Automatic Control, 53(7), pp. 1434–1448, 2008..
- [27] Dong, W., and Djapic, V., *Leader-following control of multiple nonholonomic systems with over directed communication graphs*, Int. J. of Systems Science, 2014.
- [28] Xu, Y., Tian, Y. P., and Chen, Y., *Output consensus for multiple non-holonomic systems under directed communication topology*, International Journal of Systems Science, 46(3), pp. 451–463, 2015.
- [29] Wang, L., and Xiao, F., *Finite-time consensus problems for networks of dynamic agents*, IEEE Transactions on Automatic Control, 55(4), pp. 950–955, 2010.
- [30] Cao, Y., and Ren, W., *Distributed coordinated tracking with reduced interaction via a variable structure approach*, IEEE Trans. Aut. Cont., 57(1), pp. 33–48, 2012.
- [31] Khoo, S., Xie, L., and Man, Z., *Robust finite-time consensus tracking algorithm for multirobot systems*, IEEE/ASME Trans. Mechatronics, 14(2), pp. 219–228, 2009.
- [32] Li, S., Du, H., and Lin. X., *Finite-time consensus algorithm for multi-agent systems with double-integrator dynamics*, Automatica, 47(8), pp. 1706–1712, 2011.
- [33] Cao, Y., and Ren, W., *Finite-time consensus for multi-agent networks with unknown inherent nonlinear dynamics*, Automatica, 50(10), pp. 2648–2656, 2014.
- [34] Ou, M., Du, H., and Li, S., *Finite-time formation control of multiple nonholonomic mobile robots*. International Journal of Robust and Nonlinear Control, 24(1), pp. 140–165, 2014.
- [35] Polyakov, A., *Nonlinear feedback design for fixed-time stabilization of linear control systems*. IEEE Trans. Aut. Cont., 57(8), pp. 2106–2110, 2012.
- [36] Zuo, Z., and Tie, L., *Distributed robust finite-time nonlinear consensus protocols for multi-agent systems*, Int. J. Systems Science, pp. 1–12, 2014.
- [37] Defoort, M., Polyakov, A., Demesure, G., Djemai, M., and Veluvolu, K., *Leader-follower fixed-time consensus for multiagent systems with unknown nonlinear inherent dynamics*, IET Control Theory and Applications, 2015.
- [38] Zuo, Z., *Nonsingular fixed-time consensus tracking for second-order multi-agent networks*. Automatica, 54, pp. 305–309, 2015.
- [39] Filippov, A., *Differential equations with discontinuous right-hand side*, Kluwer Academic, Dordrecht, 1988.
- [40] Bhat, S., and Bernstein, D., *Geometric homogeneity with applications to finite time stability*, Mathematics of Control, Signals and Systems, 17, pp. 101–127, 2005.