



HAL
open science

Flexible Gripper System for Small Optical Assemblies – Final Tests and Findings

Timo Prusi, Riku Heikkilä, T. H. Ha, J. Y. Song, C. W. Lee, Reijo Tuokko

► **To cite this version:**

Timo Prusi, Riku Heikkilä, T. H. Ha, J. Y. Song, C. W. Lee, et al.. Flexible Gripper System for Small Optical Assemblies – Final Tests and Findings. 6th International Precision Assembly Seminar (IPAS), Feb 2012, Chamonix, France. pp.57-64, 10.1007/978-3-642-28163-1_8 . hal-01363882

HAL Id: hal-01363882

<https://inria.hal.science/hal-01363882v1>

Submitted on 12 Sep 2016

HAL is a multi-disciplinary open access archive for the deposit and dissemination of scientific research documents, whether they are published or not. The documents may come from teaching and research institutions in France or abroad, or from public or private research centers.

L'archive ouverte pluridisciplinaire **HAL**, est destinée au dépôt et à la diffusion de documents scientifiques de niveau recherche, publiés ou non, émanant des établissements d'enseignement et de recherche français ou étrangers, des laboratoires publics ou privés.



Distributed under a Creative Commons Attribution 4.0 International License

Flexible Gripper System for Small Optical Assemblies – Final Tests and Findings

Timo Prusi¹, Riku Heikkilä¹, T.H. Ha², J.Y. Song², C.W. Lee², Reijo Tuokko¹

¹ Tampere University of Technology, Department of Production Engineering,
Korkeakoulunkatu 6, 33720 Tampere Finland
{timo.prusi, riku.heikkila, reijo.tuokko}@tut.fi

² Nano Convergence and Manufacturing Systems Research Division, Korea Institute of
Machinery and Materials (KIMM), 171, Jang-dong, Yuseong-gu, Daejeon, 305-343, South
Korea

Abstract. This paper presents our work on developing a flexible, adaptive and multifunctional gripper system for the assembly of camera phone lens modules. Key features of the system include tool change system for different end tools and visual position measurement of the component after grasping. This paper presents the development work and discusses the findings of system tests carried out in order to validate the developed gripper system.

Keywords: Miniaturized gripper, Assembly, Small optics.

1 Introduction

The number of handheld devices with integrated cameras has increased exponentially during past years. Every camera needs optical components to focus the image on camera detector. Therefore also the production capacity and production techniques for small lens modules need development. This paper introduces an industrial case study for developing a gripper system capable of assembling lens modules consisting of small and fragile optical components. The developed gripper system is flexible, adaptive and multifunctional with a modular tool change mechanism and integrated visual position measurement of the component after grasping.

Earlier publications from this study [1 - 3] describe our previous work. This paper presents results from final tests and, most importantly, presents and discusses our findings during the development work and tests. Although this paper only focuses on this specific case, the ideas we present can be generalized to other applications in the field of gripping and assembling small size parts.

2 Case Product

The developed gripper system was mainly designed for the case product presented in this chapter. However, because of the modular structure and easy tool change mechanism, the gripper can be used to handle any component that has similar dimensions as the components in our case product.

The case product is a mobile phone lens module consisting of nine parts shown in Fig 1 (a) where the parts are in assembly order from right to left: base part (barrel), lens 1, spacer 1, etc. until the lock ring which is the leftmost part in Fig 1 (a). The diameters of the parts range from 4 to 7 mm

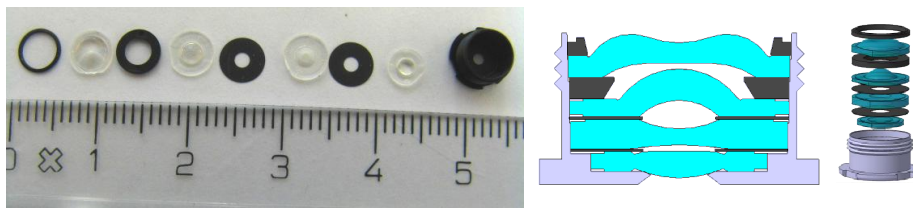

Fig 1. Components of the lens module, cross section and exploded view of the assembled lens module

As Fig 1 shows, the lenses have three dimensional shapes that in some cases make grasping more difficult. Furthermore, the optically active area of the lenses cannot be scratched. The shape and small wall thickness of the lock ring make it difficult to grasp in a way that it can still be assembled inside the base part on top of lens 4.

Looking at the parts in Fig 1, it is clear that redesigning the parts would make automatic handling easier. One small but important change would be to modify the parts to have identical gripping area at the outer edge which is not optically active. Another small but helpful change would be modifying the base part (barrel) to have (two or) three vertical “grooves” so that there would be a small space between the lens or spacer ring and the barrel. In this way it would be possible to use finger gripper. Both of these modifications would significantly reduce the number of end tools needed. However, designing or adding such changes was not in the scope of this project.

3 Gripper System

Because the gripper design is described in detail in [1 - 3], this chapter only describes the design on a coarse level. Shortly, the basic idea is to suspend the tool coaxially below an integrated camera. One vacuum locks the end tool to tool body and a second vacuum line sucks the part into the gripper. After that, the integrated camera can measure the exact position and orientation of the part relative to the gripper. Part rotation is compensated by rotating the see-through secondary body. Therefore any 3 degree-of-freedom XYZ manipulator can do the assembly movements.

3.1 Gripper Design

Fig 2 a) shows the gripper and its cross section. The parts of the gripper are: a) board level camera, b) extension tube for camera optics, c) camera optics, d) rotating see-through secondary body, e) tool body and changeable end tool, f) part grasped in gripper, g) motor rotating the secondary body, and h) the main body keeping the camera at correct working distance from the end tool. The length of the gripper is mainly determined by the working distance of the camera and its optics. The current design uses a 20 mm extension tube to shorten the working distance and currently the total height of the gripper is 123 mm.

Since there is no space between the lens and the base part and because gripper is not allowed to touch the optically active center part of the lens, the only available gripping surface is the outer edge of the upper surface. In our opinion, vacuum gripping is the best possible method for this case even though there are other quite exotic methods, such as, ice gripping.

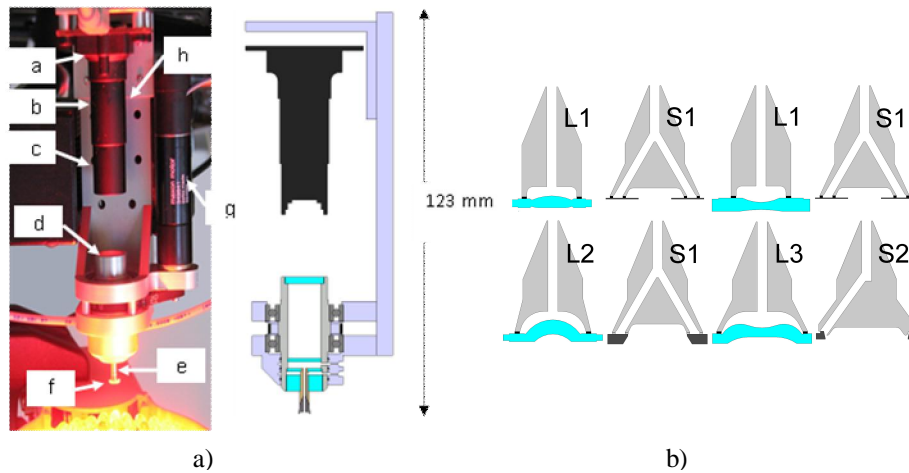

Fig 2. a) Image and cross section of the gripper. b) Five different end tools for grasping eight parts

3.2 End Tools

Designed gripper can easily adapt to different parts using changeable end tools. With our case product we needed five different end tools for the eight parts. Designing the end tools was straightforward as we only needed to consider the shape of the surface and available flat grasping areas. However, the manufacturing of these small end tools with small diameter drillings proved to be very difficult. Fig 2 b) shows the end tools: tool L1 for lenses 1 & 2; tool S2 for spacers 1 & 2 & 3; tools L2 and L3 for lenses 3 and 4 (respectively); and finally tool S2 for lock ring. Fig 3 shows images of the tools.

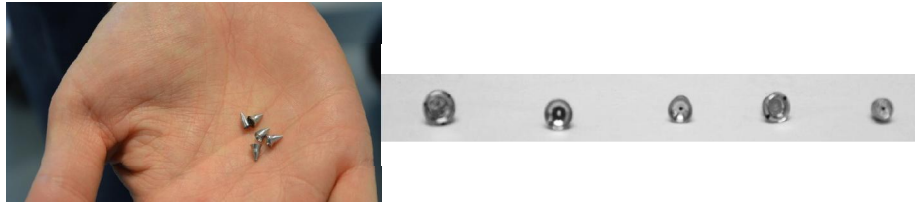

Fig 3. Five end tools. From left to right: S2, L3, L2, S1, L1.

3.3 Integrated Camera Systems

The main task of the integrated camera system is to a) verify that a lens or spacer ring was successfully picked from the feeder and b) locate it relative to gripper center. After locating the part in gripper, we can modify the robot assembly movement into fixed base part position. By selecting suitable background and illumination, the camera suspended coaxially above the tool produces images such as the leftmost image in Fig 4. From these images, it is relatively easy to find and locate the parts based on their outer edges.

Soon we noticed that if we capture an image over the base part, we can see and locate both the base part and lens at the same time. In this way it is possible to adapt to small changes in how the part is grasped and what is the exact location of the base part. Because the parts already have some (and could have much more) self-aligning features, the positioning can be relatively coarse which eases image processing.

We decided to integrate the camera to gripper mainly in order to save cycle time: now we can locate the part in gripper during robot movement instead of slowing down or stopping for capturing the image with a stationary camera. Also seeing the base part and part at the same time would be impossible with stationary camera(s). Therefore we consider that integrated camera system is a better choice even though stationary camera(s) would simplify many issues in gripper design.

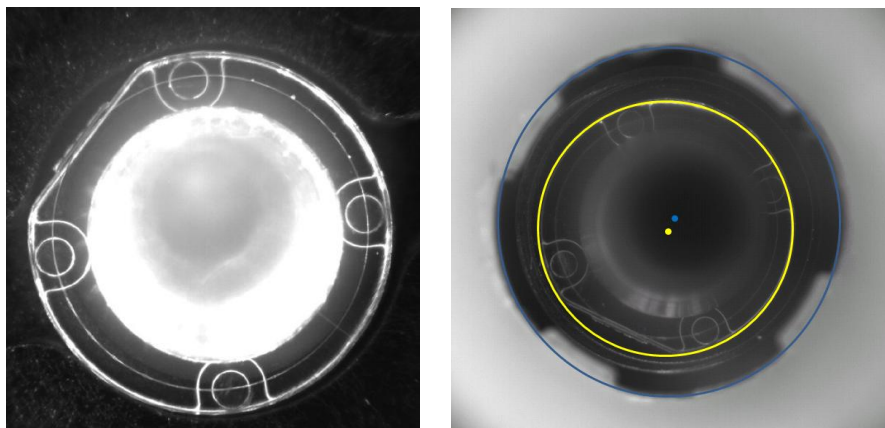

Fig 4. Images taken with integrated camera. On left, lens with black background. On right, lens and base part on the background.

In the current design camera optic's working distance is the main factor defining the length of the gripper. If we want to make a shorter gripper, we have to get the camera closer to end tool. By using suitable optics this is possible; however, bringing camera closer to the end tool creates new problems. The main problem would be that the closer the camera is to the end tool, the bigger area of the image is blocked and blurred by the tool body and end tool thus making locating small diameter parts impossible. Fig 5 uses simple pin-hole model to illustrate how the portion of the (constant size) camera field-of-view blocked by tool body increases if the camera is closer to the end tool. This problem could be avoided by using telecentric optics. However, we did not find small enough commercially available telecentric lenses. Other way to minimize the area blocked by the tool body is to make the secondary body smaller and the tool body shorter. Unfortunately this would make the manufacturing of the gripper even more difficult.

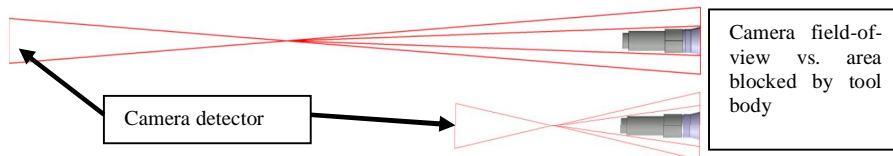

Fig 5. Pin-hole model illustrates how bringing camera closer increases the portion of camera field-of-view blocked by tool body

During the tests we also found out that vacuum lines for locking the end tool and grasping the part suck dirt inside the secondary body between the glasses. Dirt creates fuzziness into the images and makes part location less robust. Also dust, dirt or burr on lens/spacer edges causes major problems to our current image processing algorithms. In order to increase the reliability of this gripper system these problems have to be fixed.

4 Tests and Findings

In order to validate the functionality of the gripper, we carried out some tests.

4.1 Test Setup

In our tests we used normal 6 degree-of-freedom industrial robot to carry the gripper system. Because part can be rotated around Z axis with the gripper's rotating secondary body, our robot is unnecessary large and complicated as a simple 3 degree-of-freedom XYZ Cartesian manipulator would be sufficient. However, we decided to use it as it was available and interfacing with it was easy. Fig 6 shows the test setup.

In addition to robot, also the layout of the lens trays, spacer "feeder" and assembly jig are not optimized. Since the purpose of these tests, however, was only to validate the functionality of the gripper system and, for that purpose, the test setup is adequate.

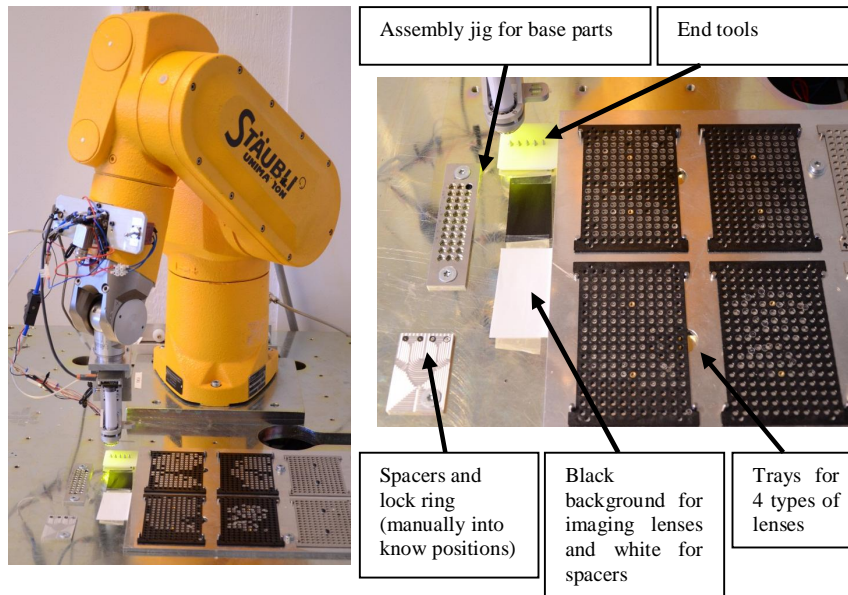

Fig 6. Test setup

4.2 Test Results – Assembly Cycle Times

When assembling lens modules one at the time, the current case product needs a tool change after assembling each part. Complete assembly cycle of assembling all eight parts therefore consists of 24 tasks (pick tool 1, assemble lens 1, release tool 1, pick tool 2, assemble spacer 1, release tool 2, etc.). Each task was then divided into four steps: 1) move above pick position, 2) pick tool/part, 3) move above release/assembly position, and 4) release/assemble tool/part. We videoed several assembly cycles and, from the videos, measured the durations of each phase of the work cycle. When running the unoptimized assembly work cycle with low accelerations and slow speeds, one full assembly cycle took 85 seconds.

Considering that the lenses are fed to robot in trays of 185 pieces, assembling lenses in the way described above is not feasible. More realistic way would be to first assemble all 185 lenses of type 1 to a matrix of 185 base parts, then change the tool, assemble 185 spacers, change the tool, etc. This would lower the number of needed tool changes considerably. Using the previously measured step durations, the calculated assembly time would lower to 47 seconds / lens which is 55% of the cycle time of batch size 1.

Even more realistic scenario would be to have a dedicated robot for assembling each part. In this scenario tool changes would be unnecessary and end tools could be static. This would enable higher accelerations and speeds and therefore considerably faster assembly times. In this scenario and utilizing on-the-fly imaging, the limiting factor would probably be the needed image processing time and communication delays between machine vision system and robot movement control.

4.3 Test Results - End Tools

The optically active area in the center part of the lenses cannot be scratched or otherwise damaged during handling and assembly. We were worried that the end tool's steel surface would damage the lens and therefore we did 100 pick-and-place cycles (from and to lens tray) for one single lens. Fig 7 shows lens (type 2) before and after this test. Carefully looking there is some fuzziness on the lens surface where end tool has been in contact with the lens. To prevent damage to lenses, we thought about and tried coating the contact surface of end tool with rubber. Applying and bonding thin enough rubber coating to such a small area of the end tool proved to be very difficult. However, since the end tools do not touch the optically active areas of the lenses, we think that rubber coating is not necessary.

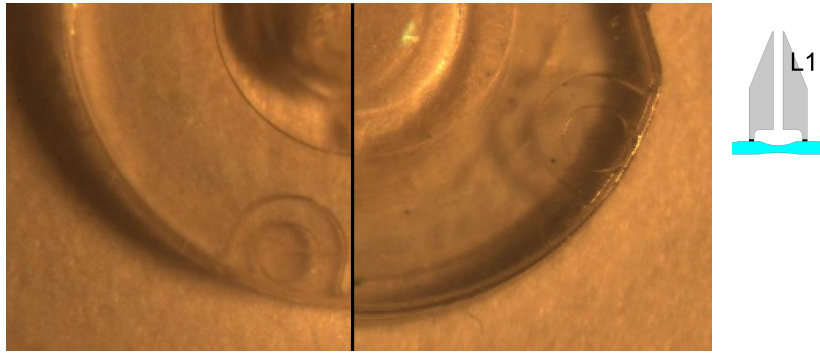

Fig 7. Lens before (left) and after (right) 100 pick-and-place cycles.

5 Discussion, Conclusions and Summary

Based on our tests presented and discussed above, we can conclude that the developed gripper system is capable of assembling the case product. Considering industrial use there are, however, a few challenges. These are: 1) End tools, 2) tool body structure and 3) maintenance and cleaning.

End tools are not mechanically locked and the vacuum force attaching them to tool body is small. Therefore end tools occasionally dropped during fast and high acceleration robot movements. Since end tools are small in size, they are very easy to lose. Small size and needed small vacuum channels make the end tools difficult to manufacture and therefore they are expensive.

The lower tip and edge of the tool body is fragile and it will be damaged in collisions. Since the tool body is glued to the glass plates, the whole glass assembly has to be changed in case tool body gets damaged. This is difficult operation and the long and thin holes ($D = 0.5$ mm, $L = 10$ mm) in the tool body make also this part difficult and expensive to manufacture.

For maintaining and cleaning the glass assembly, it would be important to be able to remove the dirt that vacuum lines suck between the glasses. In the current design this practically impossible.

To overcome these challenges, we designed a new version of the gripper with dismountable glass suspension parts, integrated optics and a smaller board level camera. We also left out the rotation of the tool since assembly type operations are usually done with robots with rotation, e.g. Scara type robots. In this version the tool body is glued to the thickest glass plate. In addition, the upmost glass plate is glued to gripper body. All other components and glass plates are fastened with screws to gripper body so that they can be removed and cleaned or replaced easily when needed. The dimensions of specified board level camera (32 x 32 x 7 mm) and relay lens (6.25 x 12.5 mm) are from commercially available components. The length of the gripper is now only 60.2 mm and this setup would create a blurred area of 3.8 mm in diameter.

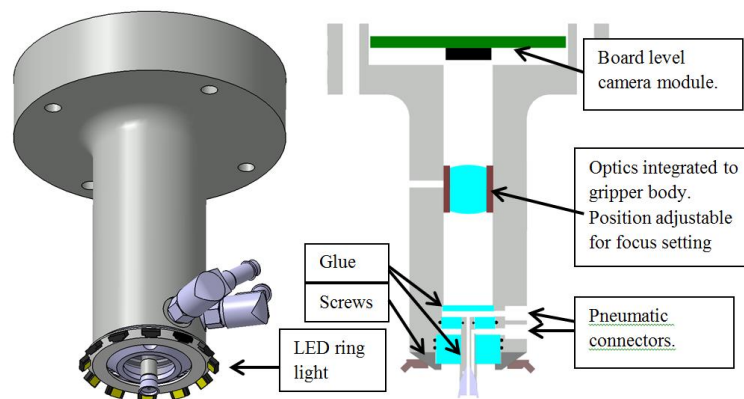

Fig 8. Redesigned gripper

To summarize, we have shortly presented the development of a flexible gripper system for small optical assemblies. We also presented the tests we made in order to validate the functionality of the gripper and discussed the findings of our tests and necessary improvements before this gripper could be used in industry.

References

- [1] Heikkilä, Riku; Prusi, Timo; Ha, T. H.; Song, J. Y.; Lee, C. W.; Tuokko, Reijo 2010. Adaptive gripper system for small optical assemblies . Proceedings of the 7th International Workshop on Microfactories, IWMMF 2010, 24-27 October, 2010, Daejeon, Korea 308-312.
- [2] Heikkilä, R., Prusi, T., Remes, M., Tuokko, R., Ha, T. H., Song, J. Y. & Lee, C. W. 2009. Development of a flexible gripper system for small optical assemblies. In: Saile, V., Ehmann, K. & Dimov, S. (eds.). 4M/ICOMM 2009, The Global Conference on Micro Manufacture, Incorporating the 5th International Conference on Multi-Material Micro Manufacture (4M) and the 4th International Conference on Micro Manufacturing (ICOMM), 23rd-25th September 2009, Karlsruhe, Germany pp. 371-374.
- [3] Remes, M., Heikkilä, R., Prusi, T., Ha T. H., Song, J. Y., Lee C. W. & Tuokko, R. 2008. Flexible gripper system for small optical assemblies. Proceedings of MSEC 2008 ASME International Conference on Manufacturing Science and Engineering and ICM&P 3rd JSME/ASME International Conference on Materials and Processing, October 7-10, 2008, Evanston, IL, USA 1 p.