



HAL
open science

Composite Asymptotic Expansions and Difference Equations

Augustin Fruchard, Reinhard Schäfke

► **To cite this version:**

Augustin Fruchard, Reinhard Schäfke. Composite Asymptotic Expansions and Difference Equations. *Revue Africaine de Recherche en Informatique et Mathématiques Appliquées*, 2015, Volume 20 - 2015 - Special issue - Colloquium in Honor of Éric Benoît, pp.63-93. 10.46298/arima.1986 . hal-01320625

HAL Id: hal-01320625

<https://inria.hal.science/hal-01320625>

Submitted on 24 May 2016

HAL is a multi-disciplinary open access archive for the deposit and dissemination of scientific research documents, whether they are published or not. The documents may come from teaching and research institutions in France or abroad, or from public or private research centers.

L'archive ouverte pluridisciplinaire **HAL**, est destinée au dépôt et à la diffusion de documents scientifiques de niveau recherche, publiés ou non, émanant des établissements d'enseignement et de recherche français ou étrangers, des laboratoires publics ou privés.



Composite Asymptotic Expansions and Difference Equations

Augustin Fruchard* — Reinhard Schäfke**

* Laboratoire de Mathématiques, Informatique et Applications, EA 3993
Faculté des Sciences et Techniques, Université de Haute Alsace 4, rue des Frères Lumière
68093 Mulhouse cedex
France
Augustin.Fruchard@uha.fr

** Institut de Recherche Mathématique Avancée, UMR 7501
U.F.R. de Mathématiques et Informatique
Université Louis Pasteur et C.N.R.S.
7, rue René Descartes
67084 Strasbourg cedex
France
schafke@math.u-strasbg.fr



ABSTRACT. Difference equations in the complex domain of the form $y(x+\varepsilon)-y(x) = \varepsilon f(y(x))/y(x)$ are considered. The step size $\varepsilon > 0$ is a small parameter, and the equation has a singularity at $y = 0$. Solutions near the singularity are described using composite asymptotic expansions. More precisely, it is shown that the derivative v' of the inverse function v of a solution (the so-called Fatou coordinate) admits a Gevrey asymptotic expansion in powers of the square root of ε , denoted by η , involving functions of y and of $Y = y/\eta$. This also yields Gevrey asymptotic expansions of the so-called Ecalle-Voronin invariants of the equation which are functions of ε . An application coming from the theory of complex iteration is presented.

RÉSUMÉ. On considère des équations aux différences dans le plan complexe de la forme $y(x + \varepsilon) - y(x) = \varepsilon f(y(x))/y(x)$. Le pas de discrétisation $\varepsilon > 0$ est un petit paramètre, et l'équation a une singularité en $y = 0$. On décrit les solutions près de la singularité en utilisant des développements asymptotiques combinés. Plus précisément, on montre que la dérivée v' de la fonction réciproque (appelée coordonnée de Fatou) v d'une solution admet un développement asymptotique Gevrey en puissances de la racine carrée de ε , notée η , et faisant intervenir des fonctions de y et de $Y = y/\eta$. On obtient également des développements asymptotiques Gevrey des invariants d'Écalle-Voronin de l'équation, qui sont des fonctions de ε . Une application venant de la théorie de l'itération complexe est présentée.

KEYWORDS : difference equation with small step size, composite asymptotic expansion, Gevrey asymptotic, Fatou coordinate, Ecalle-Voronin invariants.

MOTS-CLÉS : Équation aux différences à petit pas, développement asymptotique combiné, asymptotique Gevrey, coordonnée de Fatou, invariant d'Écalle-Voronin.

1. Introduction.

The main purpose of this article is to assemble two theories, which match each other particularly well, in order to obtain new results on solutions of a difference equation with singularity. The first theory, *difference equations with small step size in the complex domain*, is developed in [3]. It concerns equations of the form

$$\Delta_\varepsilon y = f(x, y, \varepsilon) \quad (1.1)$$

where $f : \Omega \subseteq \mathbb{C} \times \mathbb{C}^N \times [0, \varepsilon_0] \rightarrow \mathbb{C}^N$ is holomorphic in x and y and continuous in ε , $\varepsilon > 0$ is a small parameter, and Δ_ε is the difference operator given by

$$\Delta_\varepsilon y(x) = \frac{1}{\varepsilon}(y(x + \varepsilon) - y(x)). \quad (1.2)$$

The first main result of [3] is that, on horizontally convex domains, there exist solutions of (1.1) close to any solution of the limiting differential equation

$$y' = f(x, y, 0). \quad (1.3)$$

A domain of \mathbb{C} is called *horizontally convex* if, for all its points x, x' with $\text{Im } x = \text{Im } x'$, the segment $[x, x']$ is contained in it. More precisely, given $y_0 : D \rightarrow \mathbb{C}^N$ a solution of (1.2) holomorphic on some x -domain D such that $(x, y_0(x), \varepsilon) \in \Omega$ for all $x \in D$ and all $\varepsilon \in [0, \varepsilon_0]$, given an initial condition $(x_0, d(\varepsilon))$, $d : [0, \varepsilon_0] \rightarrow \mathbb{C}^N$ continuous with $d(0) = y_0(x_0)$, and given a horizontally convex domain H compactly contained in D , it is shown in [3] that there exist $\varepsilon_1 \in]0, \varepsilon_0]$ and a family of solutions $y : D \times]0, \varepsilon_1] \rightarrow \mathbb{C}^N$ of (1.1), continuous, holomorphic in x , such that $y(x_0, \varepsilon) = d(\varepsilon)$ and $y(x, \varepsilon) = y_0(x) + \mathcal{O}(\varepsilon)$ on H .

A second result of [3] is that two solutions of (1.1) which coincide at some point of D are exponentially close one to each other on the domain D . The last main result is that, provided f is holomorphic in ε in a complex neighborhood of 0 and $d(\varepsilon)$ has an asymptotic expansion $d(\varepsilon) \sim \sum_{n \geq 0} d_n \varepsilon^n$ as $\varepsilon \rightarrow 0$, the above solutions y have an asymptotic expansion $\sum_{n \geq 0} y_n(x) \varepsilon^n$ as $\varepsilon \rightarrow 0$ uniformly on D , where the coefficients y_n are holomorphic functions on D and can be determined recursively as solutions of certain initial value problems of the form

$$y'_n = \frac{\partial f}{\partial y}(x, y_0(x), 0)y_n + F_n(x, y_0(x), \dots, y_{n-1}(x)), \quad y_n(x_0) = d_n. \quad (1.4)$$

The second theory in the title of the present article, *composite asymptotic expansions*, is developed in [4]. It deals with asymptotic expansions of functions of two variables x and η , using at the same time functions of x and functions of the quotient $\frac{x}{\eta}$.

At the origin this theory was developed to study singularly perturbed differential equations of the form

$$\varepsilon y' = f(x)y + \varepsilon P(x, y, \varepsilon) \quad (1.5)$$

near a turning point. Here a *turning point* is a zero of the function f . Without loss, we assume that this turning point is at the origin $x = 0$. Let the integer $p \geq 2$ be such that the order of the zero of f at $x = 0$ is $p - 1$, and let $\eta = \varepsilon^{1/p}$. One of the main results of [4] is that there exists a solution y of (1.5) defined for ε in a sector

$$S(-\delta, \delta, \varepsilon_0) = \{\varepsilon \in \mathbb{C} ; |\varepsilon| < \varepsilon_0 \text{ and } -\delta < \arg \varepsilon < \delta\}$$

and for x in a so-called *quasi-sector* $V(\alpha, \beta, r, \mu|\eta)$, $\mu < 0$ (hence depending on $|\eta| = |\varepsilon|^{1/p}$), where

$$V(\alpha, \beta, r, \rho) = \{x \in \mathbb{C} ; -\rho < |x| < r \text{ and } \alpha < \arg x < \beta\}$$

with $\rho < 0$, and that this solution has a *composite asymptotic expansion* (CASE for short) in the following sense. There exist a disc $D(0, r)$, an infinite quasi-sector $V = V(\alpha - \delta, \beta + \delta, \infty, \mu)$, and holomorphic functions $a_n : D(0, r) \rightarrow \mathbb{C}$ and $g_n : V \rightarrow \mathbb{C}$, g_n having an asymptotic expansion without constant term at infinity, such that

$$y(x, \varepsilon) \sim_{\frac{1}{p}} \sum_{n \geq 0} \left(a_n(x) + g_n\left(\frac{x}{\eta}\right) \right) \eta^n. \tag{1.6}$$

The symbol \sim means that a partial sum up to order N gives an approximation of the solution to order η^N , which is uniform in the whole domain $\varepsilon \in S(-\delta, \delta, \varepsilon_0)$, $x \in V(\alpha, \beta, r, \mu|\eta)$. Therefore, formula (1.6) provides an approximation of the solution at the same time near the turning point and away from it, i.e. at distances of order η from the turning point as well as at distances of order 1. The extra symbol $\frac{1}{p}$ means that we also have estimates of Gevrey type for the remainders; some details can be found below Theorem 2.4.

In the present article, we use this theory of CASEs in order to describe solutions of a difference equation with singularity. For the sake of simplicity, we consider an *autonomous* difference equation, i.e. with a right hand side depending only of y . We assume that the equation has a singularity. Fixing this singularity at 0, we assume that $y = 0$ is a simple pole of the right hand side. In other words, we consider a difference equation of the form

$$\Delta_\varepsilon y = \frac{1}{y} f(y), \tag{1.7}$$

where $f : U \subseteq \mathbb{C} \rightarrow \mathbb{C}$ is holomorphic in a domain U containing 0, $f(0) \neq 0$, and our purpose is to study the behavior of solutions of (1.7) having *small* values. Observe that the general theory described above applies on domains where the values of a solution are bounded away from 0, but this theory no longer applies near points where the solution takes small values.

A new feature of this type of equations is that the limiting equations are of two different natures: Near the origin, the *inner reduced equation* (2.6) (see Section 2 below) is

a difference equation, whereas far from the origin the *outer reduced equation* (2.2) is a differential equation. A natural question is whether an approximation of solutions of (1.7) exists, using solutions of the outer reduced equation (2.2) for x of order 1 and solutions of the inner reduced equation (2.6) for x of order ε , and which would be uniform, i.e. also for all intermediate x small with respect to 1 and large with respect to ε .

Our CASEs seem to be well adapted for this situation. It turns out, however, that we do not obtain CASEs for solutions of (1.7) but, except for a logarithmic term, for their inverse functions, called *Fatou coordinates*. Given a solution y of (1.7), let $v = v(z, \varepsilon)$ denote the inverse function of y with respect to the variable x , i.e. $z = y(x, \varepsilon) \Leftrightarrow x = v(z, \varepsilon)$. Then v is a solution of the Schröder equation

$$v\left(z + \varepsilon \frac{f(z)}{z}\right) = v(z) + \varepsilon. \quad (1.8)$$

An indication why things are much simpler in Fatou coordinates than for the solutions themselves is the following. In the case of an autonomous equation of the form (1.7) the existence of one solution y implies the existence of a family of solutions: If y is a solution of (1.7) and $\tau \in \mathbb{C}$ is fixed, then the shifted function $y_\tau : x \mapsto y(x + \tau)$ is also a solution (one could even choose an ε -periodic function for τ). If y has an asymptotic expansion and τ depends on ε , then this expansion changes considerably under such a shift. If $v = v(z, \varepsilon)$ is the inverse function of y , then the inverse of the shifted solution y_τ is simply $v_\tau : z \mapsto v(z, \varepsilon) - \tau$; this changes the asymptotics not essentially.

In order to obtain CASEs for the Fatou coordinates, we first construct solutions of (1.7), denoted y_1, \dots, y_4 , on some domains Ω_j which will be described in the sequel. Then we prove that they are invertible; the inverse functions $v_j = y_j^{-1}, j = 1, \dots, 4$, are solutions of the Schröder equation (1.8) defined on some domains containing quasi-sectors which cover an annulus $\{z \in \mathbb{C} ; -\mu|\eta| < |z| < r\}$, with some $\mu < 0 < r$ with $\eta = \varepsilon^{1/2}$. It turns out that the functions $v_{j+1} \circ v_j^{-1}$ are of the form $\text{id} + p_j$, with p_j periodic of period ε . As a consequence we obtain exponentially small estimates for the differences $v'_{j+1} - v'_j$ of the derivatives. Using a Ramis-Sibuya-type theorem we then obtain a CASE for the derivative v' of the Fatou coordinate. By integration, this yields a CASE for v , except for a logarithmic term. Using some inversion of CASEs, it might be possible to deduce a CASE for the solution y itself, but this CASE would contain powers of $\log x$ of any order. To sum up, an approximation of the solution y would be much more complicated than the approximation of its inverse.

We are particularly interested in the so-called *Écalle-Voronin invariants* [2, 7] of equation (1.7). These invariants are the Fourier coefficients of the periodic functions p_j . They play an important role in the theory of analytic equivalence of diffeomorphisms. The CASEs for the y_j yield also Gevrey asymptotic expansions for these invariants.

Application. In the last Section 7 we use our results in the special case of $f(y) = 1 + y$, i.e. the difference equation

$$\Delta_\varepsilon y = 1 + \frac{1}{y}. \quad (1.9)$$

This equation has also solutions on some infinite sectors, hence has also Écalles-Voronin invariants at infinity. The purpose of Section 7 is to compare these invariants with the Écalles-Voronin invariants at the origin. This study shows in particular that the first Écalles-Voronin invariant at infinity, when extended to all arguments of ε , has an infinite number of zeroes, which are asymptotically in an arithmetical sequence close to the imaginary axis. Section 7 only sketches some ideas of proof; the complete proofs will appear in a future article.

Equation (7.1) appears in [1] in the form of the iteration of the diffeomorphism $F_b : Z \mapsto Z + 1 + b/Z$ tangent to the identity at $Z = \infty$, i.e. with $b = \frac{1}{\varepsilon}$ and $Z = \frac{y}{\varepsilon}$ in our notation. The authors prove that the first Écalles-Voronin invariant, denoted by $\mathcal{C}_{r/s}(b)$, an entire function of b , has super-exponential growth as $|b|$ tends to infinity which implies that it has infinitely many zeros. Because of different normalizations, the link between their invariant and ours contains an additional term $\exp(2\pi i b \log b)$. This explains the different growth of the two functions and this could also be used to prove the super-exponential growth of $\mathcal{C}_{r/s}(b)$.

Beyond this last result, our motivation to study equation (2.1) was to illustrate our theory of CASes in a context where the reduced outer and inner equations are of different kinds, here a differential outer equation and a difference inner equation. We believe that our CASes can be useful for other types of functional equations, e.g. partial differential equations or other functional equations where small (or large) parameters occur.

2. Statements of the main results.

We consider the difference equation with small step size (1.7) rewritten below for convenience

$$\Delta_\varepsilon y = \frac{1}{y} f(y), \quad (2.1)$$

where $f : U \subseteq \mathbb{C} \rightarrow \mathbb{C}$ is holomorphic in a domain U containing 0, $f(0) = \frac{\alpha^2}{2} \neq 0$, $\varepsilon > 0$ is a small parameter, and Δ_ε is the difference operator given by (1.2). Equation (2.1) has two limiting equations. The first one is the so-called *outer reduced equation*

$$y' = \frac{1}{y} f(y). \quad (2.2)$$

obtained when ε tends to 0. One easily checks that equation (2.2) has a unique solution y_0 , defined in a neighborhood of 0 on the two-sheet Riemann surface Σ of the square root, such that $y_0(x) \sim \alpha\sqrt{x}$ as $x \rightarrow 0$ on Σ . This solution is given implicitly by $x = a_0(y_0(x))$, with

$$a_0(y) = \int_0^y \frac{t dt}{f(t)}. \quad (2.3)$$

Our purpose is to study the behavior of solutions taking small values near $x = 0$. A first idea is to perform the change of variables $x = \varepsilon X$, $y = \eta Y$ with $\eta = \sqrt{\varepsilon}$, i.e.

$$Y(X) = \frac{1}{\eta}y(\varepsilon X). \tag{2.4}$$

This transforms (2.1) into the equation

$$\Delta_1 Y = \frac{1}{Y}f(\eta Y), \tag{2.5}$$

whose limit, as $\eta \rightarrow 0$, is the second limiting equation, the *inner reduced equation*

$$Y(X + 1) = Y(X) + \frac{\alpha^2}{2Y(X)}. \tag{2.6}$$

Given $\delta > 0$ small enough and $K > 0$ large enough, consider the sector

$$\Omega_+(K, \delta) = \{X \in \mathbb{C} ; |\arg(X - K)| < \pi - \delta\}, \tag{2.7}$$

and let $Q_+(K, \delta)$ denote the image of $\Omega_+(K, \delta)$ by the function $X \mapsto \alpha X^{1/2}$, see Figure 2.1 for a sketch. Here \log is the principal determination of the logarithm on $\Omega_+(K, \delta)$, and $X^a = \exp(a \log X)$.

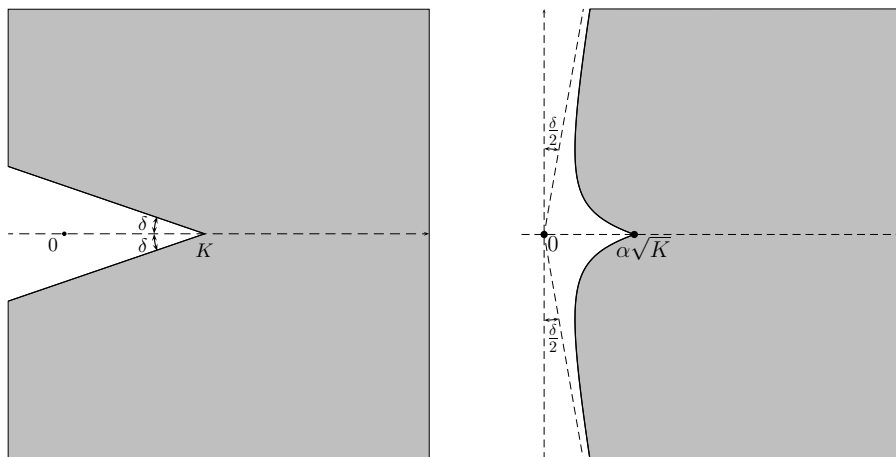

Figure 2.1. The sector $\Omega_+(K, \delta)$ and its image $Q_+(K, \delta)$ by $X \mapsto \alpha X^{1/2}$ in the case $\alpha > 0$.

Concerning the inner reduced equation (2.6), we have the following result.

Proposition 2.1 . For all $\delta > 0$ there exists $K > 0$ such that (2.6) has a unique solution Y_+ defined on $\Omega_+ = \Omega_+(K, \delta)$ satisfying

$$Y_+(X) = \alpha X^{1/2} + \frac{\alpha}{8}X^{-1/2} \log X + o(X^{-1/2}), \quad X \rightarrow \infty, X \in \Omega_+.$$

If K is large enough, then the function Y_+ has an inverse function $V_+ : Q_+(2K, 2\delta) \rightarrow \Omega_+(K, \delta)$ which satisfies

$$V_+(Z) = \left(\frac{Z}{\alpha}\right)^2 - \frac{1}{2} \log\left(\frac{Z}{\alpha}\right) + o(1), Q_+(2K, 2\delta) \ni Z \rightarrow \infty \quad (2.8)$$

and the functional equation

$$V\left(Z + \frac{\alpha^2}{2Z}\right) = V(Z) + 1 \quad (2.9)$$

whenever Z and $Z + \frac{\alpha^2}{2Z}$ are in $Q_+(2K, 2\delta)$.

Remarks. 1. This kind of statement is very classical. For the sake of completeness, however, a detailed proof is given in Section 3.

2. More precisely one has

$$Y_+(X) = \alpha X^{1/2} + \frac{\alpha}{8} X^{-1/2} \log X + \mathcal{O}(X^{-3/2}(\log X)^2), \Omega_+ \ni X \rightarrow \infty$$

and the derivative of Y_+ satisfies

$$Y'_+(X) = \frac{\alpha}{2} X^{-1/2} + \mathcal{O}(X^{-3/2}(\log X)^2), \Omega_+ \ni X \rightarrow \infty.$$

3. The function V_+ is a so-called *Fatou coordinate* of (2.6).

By symmetry of (2.6), it follows that $-Y_+$ is the only solution Y of (2.6) on Ω^+ satisfying $Y(X) = -\alpha X^{1/2} - \frac{\alpha}{8} X^{-1/2} \log X + o(X^{-1/2})$. Its inverse is the function $Z \mapsto V_+(-Z)$ defined on $-Q_+(2K, 2\delta)$; it also satisfies (2.9).

For K large enough, one proves in a similar way that there exists a unique function Y_- defined on $\Omega_- = \{X \in \mathbb{C} ; |\arg(-X - K)| < \pi - \delta\}$ satisfying

$$Y_-(X) = \alpha X^{1/2} + \frac{\alpha}{8} X^{-1/2} \log X + o(X^{-1/2}) \text{ as } X \rightarrow \infty \text{ in } \Omega_-,$$

and satisfying (2.6) for all $X \in \Omega_-$ such that $X + 1 \in \Omega_-$. Here $\log X$ is the analytic continuation of the principal branch onto Ω_- in the mathematically positive direction, i.e. $\log X = \log(-X) + \pi i$. In the same way, we continue the roots analytically by $X^{\pm 1/2} = \pm i(-X)^{\pm 1/2}$. For K large enough, we have again an inverse V_- of Y_- defined on $Q_-(2K, 2\delta) = i Q_+(2K, 2\delta)$ that satisfies (2.9) and $V_-(Z) = \left(\frac{Z}{\alpha}\right)^2 - \frac{1}{2} \log\left(\frac{Z}{\alpha}\right) + o(1)$. In order to prove these statements, the proof in Section 2 has to be modified essentially only at one point: The operator \mathbf{T} in (3.3) has to be defined using summation over all $X - n$, n positive integer.

As another solution of (2.6), we consider $-Y_-$. It is also defined on Ω_- and satisfies $-Y_-(X) = -\alpha X^{1/2} - \frac{\alpha}{8} X^{-1/2} \log X + o(X^{-1/2})$. Its inverse is the function $Z \mapsto V_-(-Z)$ defined on $-Q_-(2K, 2\delta)$; it also satisfies (2.9). In this manner, we have obtained four solutions of (2.6) and four solutions of (2.9) of particular interest.

If K is large enough, the function $\Phi_+ = V_- \circ Y_+ - \text{id}$ is defined (at least) on the sector

$$\mathcal{I}_+ = \{X \in \mathbb{C}; |\arg(X - iK) - \frac{\pi}{2}| < \frac{\pi}{2} - 3\delta\}.$$

Using (2.9), it is easily shown that Φ_+ is 1-periodic. The choice of the branches of the logarithms in Proposition 2.1 and the estimate (2.8) ensure that $\Phi_+(X) \rightarrow 0$ as $\mathcal{I}_+ \ni X \rightarrow \infty$. Therefore the Fourier series of Φ_+ must have the following form

$$\Phi_+(X) = \sum_{n=1}^{\infty} C_n^+ e^{2\pi i n X} \text{ for } X \in \mathcal{I}_+, \quad (2.10)$$

where $C_n^+ \in \mathbb{C}$ are constants.

Similarly, we treat the composition of the inverse of Y^+ with $-Y^-$. The function $\Phi_- = V_+ \circ (-Y_-) - \text{id}$ is defined (at least) on the sector

$$\mathcal{I}_- = \{X \in \mathbb{C}; |\arg(X + iK) + \frac{\pi}{2}| < \frac{\pi}{2} - 3\delta\}.$$

It is also 1-periodic, but only bounded as $\mathcal{I}_- \ni X \rightarrow \infty$ because of the choice of the branches of the logarithms. Its Fourier series is thus

$$\Phi_-(X) = \sum_{n=0}^{\infty} C_n^- e^{-2\pi i n X} \text{ for } X \in \mathcal{I}_-.$$

Here $C_0^- = \frac{\pi i}{2}$; the other constants C_n^- , $n \geq 1$ are closely related to C_n^+ , but the relation is not interesting in our work. The other analogous compositions of the inverse of $-Y^-$ with $-Y^+$, respectively that of the inverse of Y^+ with $-Y^-$, are identical to $\Phi^\pm + \text{id}$ with the above functions Φ^\pm and yield no new constants.

The constants C_n^\pm are the so-called *Écalle-Voronin invariants* [2, 7] of equation (2.6).

Let us return to our original equation (2.1). We fix $K, r, \delta > 0$. Let $z(\varepsilon) \in [-r, ir]$ be such that $\arg(z(\varepsilon) - K\varepsilon) = \pi - \delta$ and let $\Omega_1 = \Omega(K, r, \delta, \varepsilon)$ denote the interior of the (non convex) hexagon with vertices $K\varepsilon, z(\varepsilon), ir, r, -ir, \bar{z}(\varepsilon)$ in this order; see Figure 2.2. Let $\Omega_2 = \Omega_4 = -\Omega_1 = \{x \in \mathbb{C}; -x \in \Omega_1\}$ and $\Omega_3 = \Omega_1$.

We will also use the image of Ω_1 by $x \mapsto \alpha x^{1/2}$, denoted by Q_1 , and the domains $Q_j = i^{j-1}Q_1$, $j = 2, 3, 4$, obtained by rotations.

Our first main result is as follows; let us recall that $\eta = \varepsilon^{1/2}$.

Theorem 2.2 . *With the above notation, for all $\delta > 0$ there exist $K, R, \varepsilon_0, r > 0$ with $K\varepsilon_0 < r$ and four solutions y_1, y_2, y_3, y_4 of (2.1), defined for $\varepsilon \in]0, \varepsilon_0]$ and $x \in \Omega_j$, such that $y_1(K\varepsilon, \varepsilon) = -y_3(K\varepsilon, \varepsilon) = \eta Y_+(K)$, $y_2(-K\varepsilon, \varepsilon) = -y_4(-K\varepsilon, \varepsilon) = \eta Y_-(-K)$, and*

$$\forall \varepsilon \in]0, \varepsilon_0] \forall x \in \Omega_1, \quad |y_1(x, \varepsilon) - \eta Y_+(\frac{x}{\varepsilon})| \leq R|x| \text{ and } |y_3(x, \varepsilon) + \eta Y_+(\frac{x}{\varepsilon})| \leq R|x|,$$

$$\forall \varepsilon \in]0, \varepsilon_0] \forall x \in -\Omega_1, \quad |y_2(x, \varepsilon) - \eta Y_-(\frac{x}{\varepsilon})| \leq R|x| \text{ and } |y_4(x, \varepsilon) + \eta Y_-(\frac{x}{\varepsilon})| \leq R|x|.$$

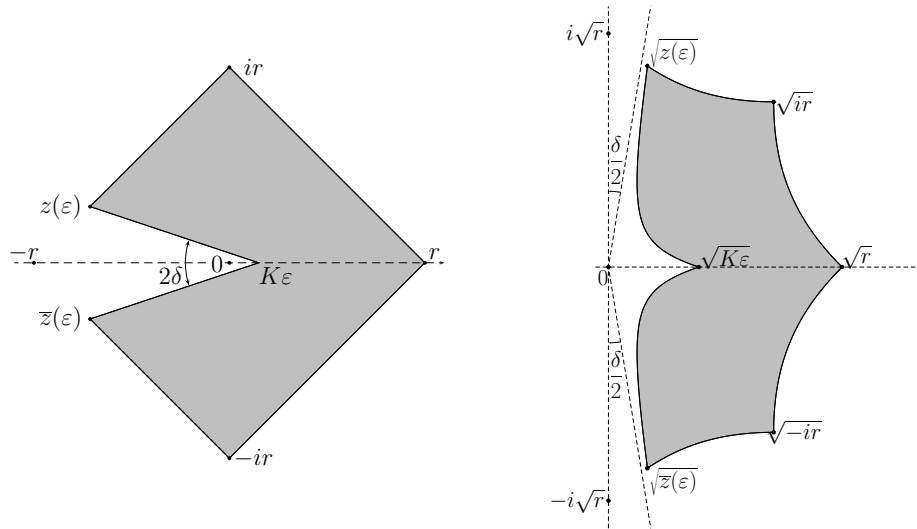

Figure 2.2. *Left: The domain Ω_1 of existence of the solutions y_1, y_3 of (2.1). Right: The image Q_1 of Ω_1 by $x \mapsto x^{1/2}$ ($\alpha = 1$ here).*

The proof is in Section 5. Since the domains are no longer infinite, we cannot have uniqueness of the solutions anymore, but they are unique up to exponentially small terms.

We then prove the existence of the inverse functions $v_j = y_j^{-1}$ analogous to the above Fatou coordinates. Precisely, let $\tilde{\Omega}_1 = \Omega(2K, \frac{r}{2}, 2\delta, \varepsilon)$ be defined as Ω_1 , with the constants $2K$, $\frac{r}{2}$, and 2δ instead of K , r , δ . We assume $\varepsilon_0 \leq \frac{r}{4K}$. Let \tilde{Q}_1 denote the image of $\tilde{\Omega}_1$ by the function $X \mapsto \alpha X^{1/2}$. As before, we also use $\tilde{\Omega}_j = (-1)^{j-1} \tilde{\Omega}_1$ and $\tilde{Q}_j = i^{j-1} \tilde{Q}_1$, $j = 2, 3, 4$. On \tilde{Q}_1 , we use the principal value of $\log(\frac{z}{\alpha\eta})$; on the other \tilde{Q}_j , we use $\log(\frac{z}{\alpha\eta}) = \log(\frac{z}{\alpha\eta} i^{1-j}) + \frac{j-1}{2} \pi i$. Thus the branches of the logarithms are the same on the intersection $\tilde{Q}_j \cap \tilde{Q}_{j+1}$ if $j = 1, 2, 3$, but *not* on $\tilde{Q}_4 \cap \tilde{Q}_1$.

Proposition 2.3 . *With the above notation, if $j \in \{1, 2, 3, 4\}$, $r > 0$ is small enough and $K > 0$ is large enough then, for all $z \in \tilde{Q}_j$, the equation $y_j(x, \varepsilon) = z$ has a unique solution $x \in \Omega_j$, denoted by $x = v_j(z, \varepsilon)$. This gives a holomorphic function v_j defined for $z \in \tilde{Q}_j$, $\varepsilon \in]0, \varepsilon_0]$, the values of which are in Ω_j . It is a solution of*

$$v\left(z + \varepsilon \frac{f(z)}{z}\right) = v(z) + \varepsilon. \tag{2.11}$$

Moreover, we have

$$v_1(\eta Y_+(K), \eta^2) = K\eta^2, \quad v_2(\eta Y_-(-K), \eta^2) = -K\eta^2, \\ v_3(-\eta Y_+(K), \eta^2) = K\eta^2, \quad \text{and} \quad v_4(-\eta Y_-(-K), \eta^2) = -K\eta^2,$$

where K is the constant of Theorem 2.2, and there exist $R, \eta_0 > 0$ such that for all $z \in \tilde{Q}_j, \eta \in]0, \eta_0]$

$$\begin{aligned} \left| v_1(z, \eta^2) - \eta^2 V_+\left(\frac{z}{\eta}\right) \right| &\leq R |z|^3, & \left| v_3(z, \eta^2) - \eta^2 V_+\left(-\frac{z}{\eta}\right) \right| &\leq R |z|^3, \\ \left| v_2(z, \eta^2) - \eta^2 V_-\left(\frac{z}{\eta}\right) \right| &\leq R |z|^3, & \text{and} & \left| v_4(z, \eta^2) - \eta^2 V_-\left(-\frac{z}{\eta}\right) \right| &\leq R |z|^3. \end{aligned}$$

The proof is analogous to that of Proposition 2.1; it will be omitted here.

For fixed $z \neq 0$ in the appropriate domains, the limits $v_j(z, 0) = \lim_{\varepsilon \rightarrow 0} v_j(z, \varepsilon)$ are solutions of $v'(z) \frac{f(z)}{z} = 1$; this is obtained easily from (2.11) in the limit $\varepsilon \rightarrow 0$. The approximation conditions of the above proposition imply that $v_j(z, 0) = a_0(z)$, where a_0 is given in (2.3).

The approximation conditions of the above proposition also imply that, for fixed Z sufficiently large such that ηZ is in the appropriate domain, $\lim_{\eta \rightarrow 0} \eta^{-2} v_j(\eta Z, \eta^2)$ is one of the four functions $V_{\pm}(\pm Z)$.

Thus we have *outer* approximations (for z fixed) and *inner* approximations (for Z fixed) for v_j . The most important result of our article refines these statements, not only to the existence of full outer and inner expansions, but to full uniform expansions in the whole domains \tilde{Q}_j . This is achieved using so-called *composite asymptotic expansions* (CASES). We refer to [4] for a detailed discussion of this notion and its properties. Nevertheless, we will give explanations below the theorem. In the present article, we adopt the notation b_n^j of [4] in case of two indices, with one index in superscript; we hope this will not bring confusion to the reader with the usual powers η^n, i^{j-1} , etc.

Theorem 2.4 . *The Fatou coordinates v_j of (2.1) have composite asymptotic expansions (CASES) of Gevrey order $\frac{1}{2}$:*

$$v_j(z, \eta^2) \sim \frac{1}{2} a_0(z) + S(\eta) \log\left(\frac{z}{\alpha\eta}\right) + T_j(\eta) + \sum_{n \geq 2} \left(a_n(z) + b_n^j\left(\frac{z}{\eta}\right) \right) \eta^n \quad (2.12)$$

as $0 < \eta \rightarrow 0$ uniformly for $z \in \tilde{Q}_j$, where a_n are analytic on $|z| < r/2$, $a_n(0) = 0$ and b_n^j are holomorphic on $i^{j-1}Q_+(2K, 2\delta)$, cf. above Proposition 2.1. The latter have consistent asymptotic expansions of Gevrey order $\frac{1}{2}$

$$b_n^j(Z) \sim \frac{1}{2} \sum_{m \geq 1} B_{nm} Z^{-m} \text{ as } Z \rightarrow \infty.$$

Furthermore, the functions S, T_j admit asymptotic expansions of Gevrey order $\frac{1}{2}$:

$$S(\eta) \sim \frac{1}{2} \sum_{n \geq 1} S_n \eta^{2n}, \quad T_j(\eta) \sim \frac{1}{2} \sum_{n \geq 2} T_{jn} \eta^n,$$

the function a_0 is given in (2.3) and the functions b_0^j, b_1^j and a_n, n odd, are identically zero. Moreover, we have $S_1 = -\frac{1}{2}, T_{12} = T_{22} = 0, T_{32} = T_{42} = \frac{1}{2}\pi i$.

By definition, (2.12) means that there exist $A, B, \eta_0 > 0$ such that, for all $\eta \in]0, \eta_0]$, all $z \in \tilde{Q}_j$, and all $N \in \mathbb{N}, N \geq 2$, one has

$$\left| v_j(z, \eta^2) - a_0(z) - S(\eta) \log\left(\frac{z}{\alpha\eta}\right) - T_j(\eta) - \sum_{n=2}^{N-1} \left(a_n(z) + b_n^j\left(\frac{z}{\eta}\right) \right) \eta^n \right| \leq AB^N \Gamma\left(1 + \frac{N}{2}\right) \eta^N.$$

The statement on the b_n^j means that there exist $A, B > 0$ such that, for all integers $n \geq 2, M \geq 1$ and all $Z \in i^{j-1}Q_+(2K, 2\delta)$, one has

$$|Z|^M \left| b_n^j(Z) - \sum_{m=1}^{M-1} B_{nm} X^{-m} \right| \leq AB^{n+M} \Gamma\left(\frac{M+n}{2} + 1\right). \tag{2.13}$$

Observe that the a_n, B_{nm} and S are independent of j , whereas the b_n^j and T_j are not.

An important consequence of (2.12) (see [4], Proposition 3.7) is the existence of so-called outer and inner expansions of v_j of Gevrey order $\frac{1}{2}$. More precisely, for every $r_1 \in]0, \frac{r}{2}[$

$$v_j(z, \eta^2) \sim_{\frac{1}{2}} a_0(z) + S(\eta) \log\left(\frac{z}{\alpha}\right) - S(\eta) \log \eta + T_j(\eta) + \sum_{n \geq 2} d_n(z) \eta^n \tag{2.14}$$

as $\eta > 0, \eta \rightarrow 0$ uniformly for $z \in \tilde{Q}_j$ with $|z| > r_1$, where $d_n(z) = a_n(z) + \sum_{m=1}^{n-2} B_{n-m,m} z^{-m}$, and for every $K_1 > 2K$

$$v_j(\eta Z, \eta^2) \sim_{\frac{1}{2}} S(\eta) \log\left(\frac{Z}{\alpha}\right) + T_j(\eta) + \sum_{n \geq 2} h_n^j(Z) \eta^n \tag{2.15}$$

as $\eta > 0, \eta \rightarrow 0$ uniformly for $\eta Z \in \tilde{Q}_j$ with $2K < |Z| < K_1$, where $h_n^j(Z) = b_n^j(Z) + \sum_{m=1}^n A_{n-m,m} Z^m$ if $a_j(z) = \sum_{k > 0} A_{jk} z^k$. Here we use that $a_0(z) = \mathcal{O}(z^2)$ and thus we also have $A_{00} = A_{01} = 0$.

The proof of Theorem 2.4 is given in Section 6. In fact we first prove, using the main result of [4], that the derivatives $v'_j(z, \varepsilon)$ of the Fatou coordinates have CASEs of Gevrey order $\frac{1}{2}$; here no logarithm appears. Because of the initial conditions of Proposition 2.3, we conclude for v_j by integration; in the case $j = 1$ for example, we have (with $\varepsilon = \eta^2$)

$$v_1(z, \varepsilon) = K\varepsilon + \int_{\eta Y_+(K)}^z v'_1(\zeta, \varepsilon) d\zeta.$$

The integration of a CASE is again treated in [4]; the logarithms appear because each term analogous to $b_n^j(Z)$ in this CASE contains a multiple of $1/Z$ in its expansion.

Remark. The right hand side of (2.12) is a composite formal series solution of (2.11). It can be shown that this determines the formal expression except for T_j ; this will be done on an example in Section 7. The (Gevrey) asymptotic expansions of $T_j(\eta)$ are determined by the initial conditions of the v_j (see below (2.11)) and the corresponding initial conditions (on a formal level) for the right hand sides of (2.12). Then the T_j can be chosen by the Borel-Ritt-Gevrey theorem as any functions having these asymptotic expansions of Gevrey order $\frac{1}{2}$.

The additive constants $T_j(\eta)$ in the expansions depend upon the initial conditions of the v_j ; especially they depend upon the choice of K^1 . To avoid problems in the sequel, we want to normalize our solutions of (2.11) such that their Gevrey asymptotic expansions are uniquely determined by the equations and normalize the solutions of (2.1) accordingly – thus the functions are determined by the equation up to exponentially small terms. More precisely, we put for $j = 1, \dots, 4$

$$v_j^*(z, \eta^2) = v_j(z, \eta^2) - T_j(\eta), \quad y_j^*(x, \eta^2) = y_j(x + T_j(\eta), \eta^2). \quad (2.16)$$

Observe that v_j^* is inverse to y_j^* and that the domains of v_j and v_j^* are the same, whereas the domain of y_j^* is obtained by shifting that of y_j . Here it is important that $T_j(\eta) = \mathcal{O}(\eta^2)$ and thus the domain of y_j^* is essentially of the same type as Ω_j . In the sequel, we can assume without loss in generality that y_j^* are defined on Ω_j and v_j^* are defined on \tilde{Q}_j as defined above, provided K is sufficiently large and $r > 0$ is sufficiently small.

It is easy to check that the functions $p_j = v_{j+1}^* \circ y_j^* - \mathbf{id}$, $j = 1, \dots, 4$,² are ε -periodic in x . A priori these functions are defined on the sets $(y_j^*)^{-1}(\tilde{Q}_{j+1}) = \{x \in \Omega_j; y_j^*(x) \in \tilde{Q}_{j+1}\}$. Their periodicity allows to continue them analytically to some strip $\{x \in \mathbb{C}; \tilde{K}\varepsilon < (-1)^{j-1}\text{Im } x < \tilde{r}\}$ with some $\tilde{K}, \tilde{r} > 0$. The Fourier coefficients c_{jn} of these functions, determined by

$$p_j(x, \varepsilon) = \sum_{n \in \mathbb{Z}} c_{jn}(\varepsilon) e^{2\pi i n x / \varepsilon}$$

are called Écalle-Voronin invariants of (2.1). It turns out that c_{jn} is exponentially small if $(-1)^{j-1}n$ is negative. For the other Écalle-Voronin invariants we have

Corollary 2.5 . *If $(-1)^{j-1}k > 0$, then the function c_{jk} admits an asymptotic expansion $\sum_{n \geq 2} a_{jkn} \eta^n$ in powers of $\eta = \varepsilon^{1/2}$, where a_{jkn} is closely related to the first Écalle-Voronin invariants of (2.6) defined in (2.10). More precisely, these are asymptotic expansion*

-
1. They also depend upon the choice of the branch of $\log\left(\frac{z}{\alpha\eta}\right)$.
 2. Here and in the sequel, the index $j + 1$ is taken modulo 4, i.e. $v_5^* = v_1^*$ etc.

sions of Gevrey order $\frac{1}{2}$ in η with closely related estimates, i.e. there exist $A, B > 0$ such that, for all positive integers N, k ,

$$\left| c_{jk}(\varepsilon) - \sum_{n=2}^{N-1} a_{jkn} \eta^n \right| \leq AB^{N+k} \Gamma\left(1 + \frac{N}{2}\right) \eta^N.$$

If the branches of the logarithms are chosen as above Theorem 2.4 for \tilde{Q}_j , then we have $a_{1k2} = C_k^+$, $a_{2,-k,2} = C_k^-$, $a_{3k2} = e^{-k\pi^2} C_k^+$ and $a_{4,-k,2} = e^{k\pi^2} C_k^-$ for positive integer k .

Idea of the proof. We indicate it only for $j = 1$. We have

$$c_{1k}(\varepsilon) = \frac{1}{\varepsilon} \int_x^{x+\varepsilon} e^{-2\pi ik\xi/\varepsilon} (v_2^* \circ y_1^*(\xi, \varepsilon) - \xi) d\xi.$$

If $k < 0$, then we can choose any x in the strip with positive imaginary part (independent of ε) and we obtain that c_{1k} is exponentially small. If $k > 0$, then the change of unknown $\xi = \varepsilon T$, $x = \varepsilon X$, with some fixed X such that $\varepsilon[X, X+1]$ is in the domain of $v_2 \circ y_1(\cdot, \varepsilon)$, yields

$$c_{1k}(\varepsilon) = \int_X^{X+1} e^{-2\pi ikT} (v_2^* \circ y_1^*(\varepsilon T, \varepsilon) - \varepsilon T) dT.$$

Now we use (2.16) and the inner expansions (2.15) for v_1 and v_2 . Since the operations of composition and inversion are compatible with Gevrey asymptotic expansions, this yields a uniform asymptotic expansion of Gevrey order $\frac{1}{2}$ for $v_2^* \circ y_1^*(\varepsilon T, \varepsilon) - \varepsilon T$. The result follows easily integrating the expansion term by term. \square

Remark. Observe that the functions $\tilde{p}_j = v_{j+1} \circ y_j - \text{id}$ defined using the non-normalized v_j, y_j satisfy $\tilde{p}_j(x, \varepsilon) = p_j(x - T_j(\eta), \varepsilon) + T_{j+1}(\eta) - T_j(\eta)$ and hence their Fourier coefficients $\tilde{c}_{jn}(\varepsilon)$ are related to the above $c_{jn}(\varepsilon)$ by

$$\begin{aligned} \tilde{c}_{j0}(\varepsilon) &= c_{j0}(\varepsilon) + T_{j+1}(\eta) - T_j(\eta), \\ \tilde{c}_{jn}(\varepsilon) &= \exp(-2\pi inT_j(\eta)/\varepsilon) c_{jn}(\varepsilon) \text{ if } n \neq 0. \end{aligned} \tag{2.17}$$

3. The reduced inner equation: Proof of Proposition 2.1.

The change of unknown $Y(X)^2 = \alpha^2 X + \frac{\alpha^2}{4} \log X + U(X)$ in (2.6) yields the equation

$$U(X+1) = U(X) + \frac{\alpha^2}{4} h(X, U(X)) \tag{3.1}$$

with

$$h(X, U) = \left(X + \frac{1}{4} \log X + \alpha^{-2} U\right)^{-1} - \log\left(1 + \frac{1}{X}\right). \tag{3.2}$$

Observe that, if U is a solution of (3.1) satisfying $U(X) = o(1)$ as $\Omega_+(K, \delta) \ni X \rightarrow \infty$, then $h(X, U(X)) \sim -\frac{\log X}{4X^2}$ as $\Omega_+(K, \delta) \ni X \rightarrow \infty$. By (3.1), U is of the same order as the antiderivative of h tending to 0 as $X \rightarrow \infty$, i.e. U is of order $\frac{\log X}{X}$.

This leads us to introduce the following space. Let \mathcal{E} denote the Banach vector space of functions U holomorphic on Ω_+ such that $\frac{XU(X)}{\log X}$ is bounded, endowed with the norm

$$\|U\| = \sup_{X \in \Omega_+} \left| \frac{XU(X)}{\log X} \right|.$$

Given $L > 0$ large enough, let $\mathcal{B}'(0, L)$ denote the closed ball of \mathcal{E} of center 0 and radius L , i.e. $\mathcal{B}'(0, L) = \{U \in \mathcal{E} ; \|U\| \leq L\}$.

Using that $X + n \in \Omega_+$ for all $X \in \Omega_+$ and all $n \in \mathbb{N}$, we now rewrite (3.1) in a fixed point form $U = \mathbf{T}U$, with

$$\mathbf{T}U(X) = -\frac{\alpha^2}{4} \sum_{n \geq 0} h(X + n, U(X + n)) \tag{3.3}$$

where h is defined in (3.2). This latter sum converges for all $X \in \Omega_+$ and all $U \in \mathcal{E}$ since $h(X, U(X)) = \mathcal{O}(X^{-2} \log X)$.

Lemma 3.1 . For all $\delta > 0$ and all $L \geq \frac{|\alpha|^2}{2 \sin^2(\delta/2)}$, there exists $K > 0$ such that $\mathbf{T} : \mathcal{B}'(0, L) \rightarrow \mathcal{B}'(0, L)$ is a contraction.

Proof. As already seen, we have, for any fixed $L > 0$ and any $U \in \mathcal{B}'(0, L)$,

$$h(X, U(X)) \sim -\frac{\log X}{4X^2} \text{ as } \Omega_+ \ni X \rightarrow \infty,$$

hence, for K large enough, we have

$$\forall U \in \mathcal{B}'(0, L) \forall X \in \Omega_+, \quad |h(X, U(X))| \leq |X^{-2} \log X|. \tag{3.4}$$

Now we use, for any $X \in \Omega_+$, that the quotient $\frac{X+n}{|X|+n}$ can be written as a convex combination of $\frac{X}{|X|}$ and 1, namely

$$\frac{X+n}{|X|+n} = \frac{|X|}{|X|+n} \cdot \frac{X}{|X|} + \frac{n}{|X|+n} \cdot 1,$$

hence has at least distance $\mu = \sin \frac{\delta}{2}$ from the origin. As a consequence, we have

$$\forall X \in \Omega_+ \forall n \in \mathbb{N}, \quad \mu(|X|+n) \leq |X+n| \leq |X|+n. \tag{3.5}$$

If $K \sin \delta \geq 1$, we can also estimate, for all $X \in \Omega_+$ and all $n \in \mathbb{N}$,

$$|\log(X+n)| \leq \pi + \ln(|X|+n).$$

With (3.3), (3.4) and (3.5), this yields

$$|\mathbf{T}U(X)| \leq \frac{|\alpha|^2}{4\mu^2} \sum_{n \geq 0} \frac{\pi + \ln(|X| + n)}{(|X| + n)^2}. \quad (3.6)$$

By a comparison of the sum and an integral, we estimate the sum of the right hand side of (3.6) by

$$\frac{\ln |X| + \pi}{|X|^2} + \int_{|X|}^{+\infty} \frac{\pi + \ln t}{t^2} dt \leq \frac{2 \ln |X|}{|X|},$$

if K is large enough. Thanks to the condition on L in the statement, we then obtain $|\mathbf{T}U(X)| \leq L \frac{\ln |X|}{|X|}$ for all $X \in \Omega_+$, i.e. $\|\mathbf{T}U\| \leq L$. Therefore $\mathbf{T}(\mathcal{B}'(0, L)) \subseteq \mathcal{B}'(0, L)$.

Now let $U, W \in \mathcal{B}'(0, L) \subset \mathcal{E}$. Using that $|X + \frac{1}{4} \log X + \alpha^{-2}U(X)| \geq \frac{1}{2}|X|$ if $U \in \mathcal{B}'(0, L)$, $X \in \Omega_+$, and if K is large enough, we estimate similarly

$$\begin{aligned} & |h(X, U(X)) - h(X, W(X))| \\ &= \left| \frac{\alpha^{-2}(W(X) - U(X))}{(X + \frac{1}{4} \log X + \alpha^{-2}U(X))(X + \frac{1}{4} \log X + \alpha^{-2}W(X))} \right| \\ &\leq 4\alpha^{-2}|X|^{-2}|U(X) - W(X)| \\ &\leq 4\alpha^{-2}|X|^{-3}|\log X| \|U - W\| \end{aligned}$$

hence

$$\|\mathbf{T}U(X) - \mathbf{T}W(X)\| \leq \mu^{-3}\|U - W\| \sum_{n \geq 0} (|X| + n)^{-3}(\pi + \ln(|X| + n)). \quad (3.7)$$

By a comparison of the sum and an integral, we estimate the sum of the right hand side of (3.7) by

$$|X|^{-3}(\pi + \ln |X|) + \int_{|X|}^{+\infty} t^{-3}(\pi + \ln t) dt \leq 2|X|^{-2} \ln |X| \leq 2|X|^{-2} |\log X|,$$

if K is large enough, hence $\|\mathbf{T}U(X) - \mathbf{T}W(X)\| \leq 2|X|^{-1}\mu^{-3}\|U - W\| |X|^{-1} |\log X|$. Choosing K such that $2|X|^{-1}\mu^{-3} \leq \frac{1}{2}$ for all $X \in \Omega_+$, we then obtain $\|\mathbf{T}U - \mathbf{T}W\| \leq \frac{1}{2}\|U - W\|$, showing that \mathbf{T} is a contraction in $\mathcal{B}'(0, L)$. \square

Let us now return to the proof of Proposition 2.1. By lemma 3.1, there exists a (unique) solution U_+ of (3.1) in the ball $\mathcal{B}'(0, L)$ of \mathcal{E} . Then the function Y_+ given by $Y_+(X) = (\alpha^2 X + \frac{\alpha^2}{4} \log X + U_+(X))^{1/2}$ is a solution of (2.6) that satisfies

$$Y_+(X) = \left(\alpha^2 X + \frac{\alpha^2}{4} \log X + \mathcal{O}\left(\frac{\log X}{X}\right) \right)^{1/2}$$

$$= \alpha X^{1/2} \left(1 + \frac{\log X}{8X} + \mathcal{O}\left(\left(\frac{\log X}{X}\right)^2\right) + \mathcal{O}\left(\frac{\log X}{X^2}\right) \right).$$

If Y_1 is another solution of (2.6) satisfying $Y_1(X) = \alpha X^{1/2} + \frac{\alpha}{8} X^{-1/2} \log X + o(X^{-1/2})$ as $\Omega_+ \ni X \rightarrow \infty$, then the function U_1 given by $Y_1^2(X) = \alpha^2 X + \frac{\alpha^2}{4} \log X + U_1(X)$ is a solution of (3.1) that satisfies $U_1(X) = o(1)$. It follows that $U_1 = \mathbf{T}U_1$, with \mathbf{T} given by (3.3) and h given by (3.2), hence $h(X, U_1(X)) = -\frac{(1+o(1))\log X}{4X^2}$, hence $U_1 \in \mathcal{E}$, hence $U_1 \in \mathcal{B}'(0, L)$ for some $L > 0$ large enough, hence $U_1 = U_+$ by Lemma 3.1.

For a proof of the statement on the derivative Y'_+ , we change K into $K + 1$ and we use Cauchy's formula

$$\varphi'(X) = \frac{1}{2\pi i} \int_{|z-X|=\sin \delta} \frac{\varphi(z)}{(z-X)^2} dz$$

applied to the function

$$\varphi : X \mapsto Y_+(X) - \alpha X^{1/2} - \frac{\alpha}{8} X^{-1/2} \log X.$$

Since $\varphi(z) = \mathcal{O}(X^{-3/2}(\log X)^2)$ uniformly for all z such that $|z - X| = \sin \delta$, we obtain $\varphi'(X) = \mathcal{O}(X^{-3/2}(\log X)^2)$ as well, hence the wanted estimate for Y'_+ . \square

Remark. Modifying δ if necessary, we can also prove that

$$Y'_+(X) = \frac{\alpha}{2} X^{-1/2} + \frac{\alpha}{8} (X^{-1/2} \log X)' + \mathcal{O}((X^{-3/2}(\log X)^2)'), \quad \Omega_+ \ni X \rightarrow \infty.$$

In order to prove the statements on the inverse function $V_+(Z)$ we show first

Lemma 3.2 . *If $K > 0$ is large enough, then for every $Z \in Q_+(2K, 2\delta)$ there exists a unique $X \in \Omega_+(K, \delta)$ such that $Y_+(X) = Z$.*

Proof. It suffices to show that for every $U \in \Omega_+(2K, 2\delta)$ there is a unique $X \in \Omega_+(K, \delta)$ such that $\alpha^{-2}Y_+(X)^2 = U$. By the estimate we proved above, we have

$$\alpha^{-2}Y_+(X)^2 = X + \frac{1}{4} \log X + o(1), \quad X \rightarrow \infty. \quad (3.8)$$

This suggests to apply Rouché's theorem to $f(X) = \alpha^{-2}Y_+(X)^2 - U$ and $g(X) = X - U$. Clearly g has exactly one zero in $\Omega_+(K, \delta)$. If we show that $|f(X) - g(X)| < |g(X)|$ on the boundary of $\Omega_+(K, \delta)$, then the hypotheses of Rouché's theorem are satisfied and we obtain the wanted statement that f has a unique zero in $\Omega_+(K, \delta)$. The fact that we work with infinite domains is not a problem here, because we can (for given U) add a circular arc $|X| = L$, $|\arg(X)| \leq \pi - \delta$ with large radius L to the boundary and the condition $|f(X) - g(X)| = \left| \frac{1}{4} \log X + o(1) \right| < |X - U| = |g(X)|$ is satisfied there.

So we want to show that, if K is large enough, then

$$\left| \alpha^{-2}Y_+(X)^2 - X \right| < |X - U| \quad \text{for } U \in \Omega_+(2K, 2\delta) \text{ and } X \in \partial\Omega_+(K, \delta). \quad (3.9)$$

By (3.8) and $\frac{\log X}{|X|} \rightarrow 0$ as $X \rightarrow \infty$ on $\partial\Omega_+(K, \delta)$, it is sufficient to show that

$$|X - U| \geq |X| \sin \delta \text{ for } U \in \Omega_+(2K, 2\delta) \text{ and } X \in \partial\Omega_+(K, \delta), \quad (3.10)$$

if K is sufficiently large. In order to show this estimate, we consider, for every X on the ray $\arg(X - K) = \pi - \delta$, its projection $U_P(X)$ on the ray $\arg(U - 2K) = \pi - 2\delta$. Let C denote the intersection of the opposite rays $\arg(X - K) = -\delta$ and $\arg(U - 2K) = -2\delta$. Since the triangle $(K, 2K, C)$ is isosceles at $2K$, we have $|X| < |X - C|$ and $|X - U_P(X)| = |X - C| \sin \delta$ for every X on the ray $\arg(X - K) = \pi - \delta$. To sum up, we have, for all $U \in \Omega_+(2K, 2\delta)$ and all X with $\arg(X - K) = \pi - \delta$

$$|X - U| \geq |X - U_P(X)| = |X - C| \sin \delta \geq |X| \sin \delta.$$

By symmetry, the same inequality holds for X on the other half of $\partial\Omega_+(K, \delta)$, i.e. X with $\arg(X - K) = -\pi + \delta$, and (3.10) is finally proved. \square

Lemma 3.2 shows the existence of an inverse function $V_+ : Q_+(2K, 2\delta) \rightarrow \Omega_+(K, \delta)$. Using a classical statement on holomorphic functions (see e.g. [6], Section 10.33) we prove that V_+ is holomorphic. Since $Y_+(X) = \alpha X^{1/2}(1+o(1))$, we first obtain $V_+(Z) = (\frac{Z}{\alpha})^2(1+o(1))$ by replacing $X = V_+(Z)$. The estimate for $Y_+(X)$ yields more precisely

$$\frac{Z}{\alpha} = V_+(Z)^{1/2} + \frac{1}{8}V_+(Z)^{-1/2} \log(V_+(Z)) + o(V_+(Z)^{-1/2})$$

and thus $V_+(Z) = (\frac{Z}{\alpha})^2 - \frac{1}{2} \log(\frac{Z}{\alpha}) + o(1)$. The functional equation for V_+ follows immediately from the difference equation (2.6) of Y_+ replacing $X = V_+(Z)$.

4. A bounded inverse of Δ_ε on a bounded domain.

Given $\delta, \varepsilon_0 > 0$ small enough, let $S = S(-\frac{\delta}{2}, \frac{\delta}{2}, \varepsilon_0)$ denote the sector

$$S = \{\varepsilon \in \mathbb{C} ; |\arg \varepsilon| < \delta, |\varepsilon| < \varepsilon_0\}.$$

As before, $\mu = \sin \frac{\delta}{2}$ and Ω_1 is described in Figure 2.2. Then Ω_1 has the following property: For all $x \in \Omega_1$ there exists a path $\gamma_x : [0, 1] \rightarrow \Omega_1 \cup \{-ir, ir, K\varepsilon\}$, joining $-ir$ and ir and passing through x , which is (μ, d) -ascending for all $d \in [-\frac{\delta}{2}, \frac{\delta}{2}]$ in the following sense: If $s < t$ then $\text{Im}((\gamma_x(t) - \gamma_x(s))e^{-id}) \geq \mu|\gamma_x(t) - \gamma_x(s)|$. In fact γ_x can be chosen piecewise polygonal.

Assume $K \geq \frac{1}{2}$ and $\varepsilon_0 \leq 2r$, and let

$$\tilde{\Omega} = \Omega_1(\varepsilon) + [-\frac{\varepsilon}{2}, \frac{\varepsilon}{2}] = \{x + \tau ; x \in \Omega_1(\varepsilon), -\frac{\varepsilon}{2} \leq \tau \leq \frac{\varepsilon}{2}\}.$$

Let \mathcal{H}_0 denote the space of bounded holomorphic functions on $\tilde{\Omega}$, endowed with the supremum norm. Observe that, for all $\varepsilon \in S$ and all $x \in \tilde{\Omega}$, we have $\frac{K}{2}|\varepsilon|\mu \leq |x| \leq 2r$.

Given $x_0 \in \text{cl}(\tilde{\Omega})$, depending on ε or not, let \mathbf{S}_{x_0} denote the integration operator defined by $\mathbf{S}_{x_0}f(x) = \int_{x_0}^x f(t)dt$.

We reproduce below some results of [3], in particular Theorem 2 and its extension for ε complex described in Section 5 of [3]. These results can be gathered in the following statement.

Proposition 4.1 . *There exists a bounded linear operator $\mathbf{U}_\varepsilon : \mathcal{H}_0 \rightarrow \mathcal{H}_0$, satisfying $\|\mathbf{U}_\varepsilon\| \leq \frac{\varepsilon}{\mu^2}$, such that, for all $x_0 \in \text{cl}(\tilde{\Omega})$, the operator $\mathbf{V}_\varepsilon^0 = \mathbf{S}_{x_0} - \varepsilon\mathbf{U}_\varepsilon$ is a right inverse of Δ_ε , i.e. we have $\Delta_\varepsilon\mathbf{V}_\varepsilon^0f(x) = f(x)$ for all $f \in \mathcal{H}_0$ and all $x \in \tilde{\Omega} \cap (\tilde{\Omega} - \varepsilon)$.*

In the sequel we present an extension of this result for other normed spaces. Given $a \in \mathbb{R}$, let \mathcal{H}_a denote the same space as \mathcal{H}_0 of bounded holomorphic functions in $\tilde{\Omega}$, but endowed with the norm $\|f\|_a := \sup_{x \in \tilde{\Omega}} |x^{-a}f(x)| < +\infty$. Observe that, if $a, b \in \mathbb{R}$, $f \in \mathcal{H}_a$, and $g \in \mathcal{H}_b$, then $fg \in \mathcal{H}_{a+b}$ and $\|fg\|_{a+b} \leq \|f\|_a\|g\|_b$.

Observe also that, if $a < b$ and $f \in \mathcal{H}_b$, then $f \in \mathcal{H}_a$ and

$$\|f\|_a \leq \tilde{r}^{b-a}\|f\|_b, \tag{4.1}$$

with $\tilde{r} = r + \frac{\varepsilon_0}{2}$. As a consequence, because we can reduce ε_0 and r if necessary, in a sum $f + g$ with $f \in \mathcal{H}_a$ and $g \in \mathcal{H}_b$, $a < b$, we will keep in mind that g can be neglected, roughly speaking.

Given a bounded linear operator $F : \mathcal{H}_a \rightarrow \mathcal{H}_b$, we denote by $\|F\|_a^b$ its norm, i.e. the best constant such that

$$\|Ff\|_b \leq \|F\|_a^b\|f\|_a \text{ for all } f \in \mathcal{H}_a. \tag{4.2}$$

The main result of this section is the following.

Theorem 4.2 . *For any $a \in \mathbb{R} \setminus \{-1\}$, there exists a linear operator $\mathbf{V}_\varepsilon : \mathcal{H}_a \rightarrow \mathcal{H}_{a+1}$ with the following properties.*

- (i) \mathbf{V}_ε is a right inverse of Δ_ε , i.e. we have $\mathbf{V}_\varepsilon f(x+\varepsilon) - \mathbf{V}_\varepsilon f(x) = \varepsilon f(x)$ for all $f \in \mathcal{H}_a$ and all $x \in \tilde{\Omega} \cap (\tilde{\Omega} - \varepsilon)$.
- (ii) \mathbf{V}_ε is bounded uniformly with respect to ε . More precisely, $\|\mathbf{V}_\varepsilon\|_a^{a+1}$ is bounded by a constant $L(a, K, r, \delta)$ depending only on a, K, r , and δ .
- (iii) In the case $a < -1$, we have $\mathbf{V}_\varepsilon f(r) = 0$ for all $f \in \mathcal{H}_a$. In the case $a > -1$, we have $\mathbf{V}_\varepsilon f(K\varepsilon) = 0$ for all $f \in \mathcal{H}_a$.

Remark. In the case $a = -1$, one cannot expect a bound independent of ε for any $\mathbf{V}_\varepsilon : \mathcal{H}_{-1} \rightarrow \mathcal{H}_0$. Indeed, this would give a bound for some \mathbf{S}_{x_0} at least on the interval $[K\varepsilon, r]$, i.e. a bound for an antiderivative of $1/x$ independent of ε on this interval, which is impossible.

Idea of proof. Given $a \in \mathbb{R} \setminus \{-1\}$ and $h \in \mathcal{H}_a$, we have to solve equation $\Delta_\varepsilon u = h$, $u \in \mathcal{H}_{a+1}$. In order to use Proposition 4.1, we make the change of unknown $u(x) = x^a v(x)$. This yields equation

$$\Delta_\varepsilon v = -c_a v + k, \quad v \in \mathcal{H}_1 \tag{4.3}$$

with

$$c_a(x) = \frac{(x + \varepsilon)^a - x^a}{\varepsilon(x + \varepsilon)^a} \quad \text{and} \quad k(x) = (x + \varepsilon)^{-a} h(x) \in \mathcal{H}_0.$$

We then consider the right inverse \mathbf{V}_ε^0 of Δ_ε given by Proposition 4.1, with a choice of x_0 depending upon whether $a < -1$ or $a > -1$. Precisely, if $a < -1$, then we choose $\mathbf{V}_\varepsilon^0 = \mathbf{S}_r - \varepsilon \mathbf{U}_\varepsilon$, and if $a > -1$, then we choose $\mathbf{V}_\varepsilon^0 = \mathbf{S}_{K\varepsilon} - \varepsilon \mathbf{U}_\varepsilon$. Actually, Lemma 4.3 below says that, in both cases, \mathbf{S} is bounded uniformly with respect to ε . The tedious and lengthy proof is omitted.

Lemma 4.3 .

- (a) If $a > -1$, then $\mathbf{S}_{K\varepsilon} : \mathcal{H}_a \rightarrow \mathcal{H}_{a+1}$ is bounded by a constant depending only on a and δ .
- (b) If $a < -1$, then $\mathbf{S}_r : \mathcal{H}_a \rightarrow \mathcal{H}_{a+1}$ is bounded by a constant depending only on a and δ .

In the sequel, \mathbf{S} alone will denote either \mathbf{S}_r or $\mathbf{S}_{K\varepsilon}$. As a consequence, a solution of equation

$$v = \mathbf{V}_\varepsilon^0(k - c_a v) = (\mathbf{S} - \varepsilon \mathbf{U}_\varepsilon)(k - c_a v)$$

will be a solution of (4.3). Passing on the left hand side the main part depending on v of the right hand side, we now rewrite this latter equation in the form

$$v + \mathbf{S}(c_a v) = \varepsilon \mathbf{U}_\varepsilon(c_a v) + \mathbf{V}_\varepsilon^0 k.$$

We then construct a right inverse \mathbf{T}_a of the operator $\text{id} + \mathbf{S}c_a : v \mapsto v + \mathbf{S}(c_a v)$ which is bounded in norm by a constant independent of ε . Now the operator $v \mapsto v - \mathbf{T}_a(\varepsilon \mathbf{U}_\varepsilon(c_a v))$ from \mathcal{H}_1 to \mathcal{H}_1 ; is close to identity, hence has an inverse, denoted by \mathbf{P} . Lastly, a solution of (4.3) is given by $v = \mathbf{P} \mathbf{T}_\varepsilon \mathbf{V}_\varepsilon^0 k$. The complete proofs will appear in a forthcoming article.

5. Proof of Theorem 2.2.

We prove the statement only for y_1 . The symmetries imply the statement for y_2 and the proof for y_3, y_4 is analogous. Before the proof, we have to introduce some notation. Set $y_+(x) = \eta Y_+(\frac{x}{\varepsilon})$; in this manner, y_+ is a solution of

$$\Delta_\varepsilon y_+ = \frac{\alpha^2}{2y_+}. \tag{5.1}$$

By Proposition 2.1, there exists a constant $C > 0$, depending only on δ , such that for K large enough, η_0 and r small enough, and all $x \in \Omega_1$,

$$|y_+(x) - \alpha x^{1/2}| \leq C|x^{-1/2}\varepsilon \log \frac{x}{\varepsilon}| \quad \text{and} \quad |y'_+(x) - \frac{\alpha}{2}x^{-1/2}| \leq C|x^{-3/2}\varepsilon(\log \frac{x}{\varepsilon})^2|. \quad (5.2)$$

In particular, the functions $x \mapsto x^{-1/2}y_+(x)$ and $x \mapsto x^{1/2}y'_+(x)$ are bounded above and below by constants independent of ε .

The notation σ_ε stands for the shift operator given by $\sigma_\varepsilon(x) = x + \varepsilon$. This operator will be used in the following Leibniz-type rule:

$$\Delta_\varepsilon(fg) = (\Delta_\varepsilon f)g + (f \circ \sigma_\varepsilon)(\Delta_\varepsilon g).$$

Let $C_j = C_j(\varepsilon)$ denote the constants

$$C_1 = \|y'_+\|_{-1/2} \quad \text{and} \quad C_2 = \|1/(y'_+ \circ \sigma_\varepsilon)\|_{1/2}. \quad (5.3)$$

Given $a \in \mathbb{R} \setminus \{-1\}$ and $f \in \mathcal{H}_a$ and $r > 0$, the closed ball of center f and radius r is denoted by $\mathcal{B}'_a(f, r)$, and \mathcal{B} is the closed ball

$$\mathcal{B} = \mathcal{B}'_{1/2}(y_+, \|\frac{y_+}{2}\|_{1/2}) \subset \mathcal{H}_{1/2}, \quad (5.4)$$

The function g is defined by

$$g(0) = f'(0) \quad \text{and} \quad g(y) = \frac{1}{y}(f(y) - f(0)) \quad \text{for } y \neq 0. \quad (5.5)$$

Our last notations are

$$G = \sup_{y \in \mathcal{B}'_+} \|g(y)\|_0 \quad \text{and} \quad G' = \sup_{y \in \mathcal{B}'_+} \|g'(y)\|_0, \quad (5.6)$$

$$R = 2C_1C_2\|\mathbf{V}_\varepsilon\|_{1/2}^{3/2}G \quad \text{and} \quad r_0 = \left(\frac{\|y_+\|_{1/2}}{2R}\right)^2 \quad (5.7)$$

with the notation of (4.2), and

$$\mathcal{B}_R = \mathcal{B}'_1(0, R) \subset \mathcal{H}_1. \quad (5.8)$$

Reducing if needed the constants ε_0 and r which define S and Ω_1 , we assume that $\tilde{r} = r + \frac{\varepsilon_0}{2} \leq r_0$. In this manner, for all $u \in \mathcal{B}_R \subset \mathcal{H}_1$, we have $u \in \mathcal{H}_{1/2}$ and

$$\|u\|_{1/2} \leq \tilde{r}^{1/2}\|u\|_1 \leq \tilde{r}^{1/2}R \leq r_0^{1/2}R = \|\frac{y_+}{2}\|_{1/2},$$

hence $y_+ + u \in \mathcal{B}$.

Let us now begin the proof. The change of unknown $y_1 = y_+ + u$ yields $\Delta_\varepsilon y_+ + \Delta_\varepsilon u = \frac{1}{y_+ + u} f(y_+ + u)$. Using (5.1) and using g given by (5.5), we obtain

$$\Delta_\varepsilon u = \frac{\alpha^2}{2(y_+ + u)} - \frac{\alpha^2}{2y_+} + g(y_+ + u) = -\frac{-\alpha^2 u}{2(y_+ + u)y_+} + g(y_+ + u).$$

We rewrite this equation as follows

$$\Delta_\varepsilon u = -\frac{\alpha^2 u}{2y_+^2} + \frac{\alpha^2 u^2}{2(y_+ + u)y_+^2} + g(y_+ + u). \quad (5.9)$$

In a first time, we consider the following linear equation

$$\Delta_\varepsilon u = -\frac{\alpha^2 u}{2y_+^2} + k. \quad (5.10)$$

In order to solve (5.10), first observe that the derivative y'_+ is a solution of the associated homogeneous equation. Indeed, differentiating (5.1) yields $\Delta_\varepsilon y'_+ = -\frac{\alpha^2 y'_+}{2y_+^2}$. We then use the method of variation of constant, i.e. the change $u = y'_+ v$. Since

$$\Delta_\varepsilon u = (\Delta_\varepsilon y'_+)v + (y'_+ \circ \sigma_\varepsilon)\Delta_\varepsilon v = -\frac{\alpha^2 y'_+}{2y_+^2}v + (y'_+ \circ \sigma_\varepsilon)\Delta_\varepsilon v,$$

equation (5.10) yields for v the equation $\Delta_\varepsilon v = \frac{k}{y'_+ \circ \sigma_\varepsilon}$. This latter equation can be solved using the operator \mathbf{V}_ε given by Theorem 4.2.

We therefore consider the operator $\mathbf{T}_\varepsilon : \mathcal{H}_0 \rightarrow \mathcal{H}_1$ given by

$$\mathbf{T}_\varepsilon k = y'_+ \cdot \mathbf{V}_\varepsilon \left(\frac{k}{y'_+ \circ \sigma_\varepsilon} \right).$$

To sum up, the operator \mathbf{T}_ε solves (5.10), i.e. $u = \mathbf{T}_\varepsilon k$ is a solution of this equation.

Lemma 5.1 . *The operator $\mathbf{T}_\varepsilon : \mathcal{H}_0 \rightarrow \mathcal{H}_1$ is bounded uniformly with respect to ε . Precisely, we have*

$$\|\mathbf{T}_\varepsilon\|_0^1 \leq C_1 C_2 \|\mathbf{V}_\varepsilon\|_{1/2}^{3/2},$$

with C_1, C_2 given by (5.3).

Proof. Let $k \in \mathcal{H}_0$; then $\frac{k}{y'_+ \circ \sigma_\varepsilon} \in \mathcal{H}_{1/2}$, hence $\mathbf{V}_\varepsilon \left(\frac{k}{y'_+ \circ \sigma_\varepsilon} \right) \in \mathcal{H}_{3/2}$, hence $\mathbf{T}_\varepsilon k \in \mathcal{H}_1$, and

$$\|\mathbf{T}_\varepsilon k\|_1 \leq C_1 \left\| \mathbf{V}_\varepsilon \left(\frac{k}{y'_+ \circ \sigma_\varepsilon} \right) \right\|_{3/2} \leq C_1 \|\mathbf{V}_\varepsilon\|_{1/2}^{3/2} \left\| \frac{k}{y'_+ \circ \sigma_\varepsilon} \right\|_{1/2} \leq C_1 C_2 \|\mathbf{V}_\varepsilon\|_{1/2}^{3/2} \|k\|_0.$$

□

Let us now return to equation (5.9). Recall that \mathcal{B}_R is defined in (5.8).

Lemma 5.2 . *If $r > 0$ and $\varepsilon_0 > 0$ are small enough and K is large enough then, for all $\varepsilon \in]0, \varepsilon_0[$, the map*

$$\mathbf{M}_\varepsilon : \mathcal{B}_R \rightarrow \mathcal{B}_R, u \mapsto \mathbf{T}_\varepsilon \left(\frac{\alpha^2 u^2}{2(y_+ + u)y_+^2} + g(y_+ + u) \right)$$

is a contraction.

Proof. Let $u \in \mathcal{B}_R$ and r, ε_0 be such that $\tilde{r} = r + \frac{\varepsilon_0}{2} \leq r_0$. We have $y_+ + u \in \mathcal{B}$, hence $\|g(y_+ + u)\|_0 \leq G$. We also have $\frac{\alpha^2 u^2}{2(y_+ + u)y_+^2} \in \mathcal{H}_{1/2}$ and

$$\left\| \frac{\alpha^2 u^2}{2(y_+ + u)y_+^2} \right\|_{1/2} \leq \alpha^2 (\|u\|_1)^2 \left(\left\| \frac{1}{y_+} \right\|_{1/2} \right)^3 \leq \alpha^2 R^2 \left(\left\| \frac{1}{y_+} \right\|_{1/2} \right)^3,$$

hence, by (4.1),

$$\left\| \frac{\alpha^2 u^2}{2(y_+ + u)y_+^2} \right\|_0 \leq \left\| \frac{\alpha^2 u^2}{2(y_+ + u)y_+^2} \right\|_{1/2} \tilde{r}^{1/2} \leq G \text{ if } \tilde{r} \leq G^2 \left(\alpha^2 R^2 \left(\left\| \frac{1}{y_+} \right\|_{1/2} \right)^3 \right)^{-2}.$$

Since $R = 2C_1 C_2 \|\mathbf{V}_\varepsilon\|_{1/2}^{3/2} G \geq \|\mathbf{T}_\varepsilon\|_0^1 G$, this proves that $\mathbf{M}_\varepsilon(u) \in \mathcal{B}_R$. We prove similarly that \mathbf{M}_ε is a contraction. \square

To conclude, the unique fixed point u^* of \mathbf{M}_ε in \mathcal{B}_R is a solution of (5.9). Moreover, since we are in the case $a = \frac{1}{2} > -1$ of Theorem 4.2(iii), we have $u^*(K\varepsilon) = 0$. Therefore the function $y_1 = y_+ + u^*$ satisfies the conditions of Theorem 2.2.

6. Fatou coordinates: Proof of Theorem 2.4.

We begin this section with some auxiliary results, which are useful not only for this section but also for Section 7. The proofs are straightforward but the details are a bit cumbersome.

To simplify notation, we do not indicate the ε -dependence of most functions. At some instances during the proofs, the domains must be reduced slightly, for example to allow a derivative of a bounded function to still be bounded. For the sake of simplicity, we will also not indicate this here.

Lemma 6.1 . *For $j = 1, 2$, let $y_j : D_j \rightarrow \mathbb{C}$ be solutions of (2.1) on domains D_j not containing 0. We suppose that $y_j(x) = y_0(x) + \mathcal{O}(\varepsilon)$ uniformly for $x \in D_j$ and that $D_1 \cap D_2$ is connected. Let b^+ , resp. $b^- \in \mathbb{R}$ denote the maximum, resp. minimum, of $\text{Im } x$ on $D_1 \cap D_2$.*

Then, for any δ small enough, there exists an ε -periodic function $p : S \rightarrow \mathbb{C}$ defined on the strip $S = \{x \in \mathbb{C} ; b^- + \delta < \text{Im } x < b^+ - \delta\}$ and satisfying $y_2(x) = y_1(x + p(x))$ for all $x \in D_1 \cap D_2 \cap S$.

By Rouché's theorem, it can be proved that y_1 is locally invertible; let v_1 denote such a local inverse. The function p is then simply given by $p(x) = v_1(y_2(x)) - x$. As both y_1 and y_2 are close to y_0 , we have $p(x) = \mathcal{O}(\varepsilon)$. Since both satisfy (2.1), the ε -periodicity of p follows.

Corollary 6.2 . *With the notation of Lemma 6.1, let $\Omega \subseteq (D_1 \cup D_2) \cap S$ be a horizontally convex domain (i.e. $x, x' \in \Omega$ and $\text{Im } x = \text{Im } x'$ imply $[x, x'] \subset \Omega$). Then the solution y_2 can be analytically continued on Ω by the formula of Lemma 6.1.*

Of course, y_2 is still a solution of (2.1) on Ω . By symmetry, y_1 can also be analytically continued on Ω by the formula $y_1(x) = y_2(x + q(x))$ with the ε -periodic function $q(x) = v_2(y_1(x)) - x$.

Corollary 6.3 . *With the above notation, there exists a function $s = s(\varepsilon)$ such that the function $R : \Omega \rightarrow \mathbb{C}$, $x \mapsto y_1(x) - y_2(x + s(\varepsilon))$ is exponentially small. More precisely, if $d(x) = \min(\text{Im } x - b^- + \delta, b^+ - \text{Im } x - \delta)$, then we have $R(x) = \mathcal{O}(e^{-2\pi d(x)/\varepsilon})$.*

The function s is simply the constant term c_0 in the Fourier expansion of p

$$p(x) = \sum_{\nu \in \mathbb{Z}} c_\nu e^{2\pi i \nu x / \varepsilon}.$$

The function s is called the *shift* in Section 7. The next result is based on general results of [3].

Corollary 6.4 . *Let $D_1 \subset D_2$ be horizontally convex domains. Assume that there exists a solution $y_1 : D_1 \rightarrow \mathbb{C}$ of (2.1) and that the solution $y_0 = a_0^{-1}$ of (2.2) is defined on D_2 . Let b^+ , resp. $b^- \in \mathbb{R}$ denote the maximum, resp. minimum, of $\text{Im } x$ on D_1 .*

Then, for any compact subset K of D_2 and any $\delta > 0$, there exists $\varepsilon_0 > 0$ such that, for all $\varepsilon \in]0, \varepsilon_0]$, y_1 can be analytically continued onto $K \cap S$, with

$$S = \{x \in \mathbb{C}; b^- + \delta < \text{Im } x < b^+ - \delta\}.$$

Actually, by Theorem 7 of [3], there exists a solution y_2 on K . Therefore, by Corollary 6.2 above, y_1 can be continued on $K \cap S$.

Proof of Theorem 2.4. A consequence of Proposition 2.3 and of the estimate for V_+ in Proposition 2.1 is that, if $\gamma > 0$ arbitrarily small is fixed, then for r small enough and K large enough, the function v_1 satisfies

$$\forall u \in \tilde{Q}_1, \quad (1 - \gamma) \left| \frac{u}{\alpha} \right|^2 \leq |v_1(u)| \leq (1 + \gamma) \left| \frac{u}{\alpha} \right|^2. \quad (6.1)$$

Now we consider other arguments for η (and thus of $\varepsilon = \eta^2$). It can be shown that Theorem 2.2 and Proposition 2.3 are also valid if the interval $]0, \varepsilon]$ is replaced by a sector with sufficiently small opening angle bisected by the positive real axis.

Then let $(S_l)_{l=1}^L$ be a good covering of the origin (in the η -plane) by sectors of opening at most 2δ . Since each η -sector S_l can be reduced to a sector bisected by the positive real axis using a rotation, the previous results can be carried over to S_l . As such a rotation changes α to $\exp(2\pi i l/L)\alpha$, this leads to functions $v_l^j, j = 1, \dots, 4$ on domains $Q_l^j = \exp(2\pi i l/L)Q_j, Q_j$ defined above Theorem 2.2, that are analogous to the functions of Proposition 2.3; especially they satisfy (2.11) and are inverse to solutions y_l^j of (2.1).

Next we show that, on the intersections $Q_l^j \cap Q_{l+1}^j$, we have

$$|(v_{l+1}^j)'(z) - (v_l^j)'(z)| \leq K \exp(-\frac{\alpha}{|\eta|^2}) \tag{6.2}$$

whereas, on the intersections $Q_l^j \cap Q_l^{j+1}$, we have

$$|(v_l^{j+1})'(z) - (v_l^j)'(z, \varepsilon)| \leq K|\eta| \exp(-\alpha|\frac{z}{\eta}|^2) \tag{6.3}$$

with some positive constants K, α .

For the proof, fix j, l . Applying Corollary 6.3 to y_l^j and y_{l+1}^j , we obtain the existence of some function $s = s(\varepsilon)$ such that $y_l^j(x) - y_{l+1}^j(x + s(\varepsilon))$ is $\mathcal{O}(e^{-\alpha/|\varepsilon|})$ on the intersection of their domains, with some constant α . This implies that $(v_{l+1}^j - v_l^j)(z) - s(\varepsilon)$ is also $\mathcal{O}(e^{-\alpha/|\varepsilon|})$ on $Q_l^j \cap Q_{l+1}^j$. Now we obtain (6.2) by differentiation.

For the proof of (6.3), we have to refine Corollary 6.3 and its proof for y_l^j and y_l^{j+1} . The function p defined by $p(x) = (v_l^{j+1} \circ y_l^j)(x) - x$ is ε -periodic and bounded on some strip one boundary of which passes at a distance of $K|\varepsilon|$ from the origin. Using the Fourier series for p , its constant term c_0 and estimates for the other coefficients, we prove that $p(x) - c_0(\varepsilon) = \mathcal{O}(|\varepsilon|e^{-\mu|x|/|\varepsilon|})$ with some positive μ . The factor ε comes from the estimate for v_l^j near the origin and the corresponding estimates for Fourier coefficients.

Carrying this over to v_l^{j+1} and v_l^j , we obtain that

$$(v_l^{j+1} - v_l^j)(z) - c_0(\varepsilon) = \mathcal{O}\left(|\varepsilon|e^{-\tilde{\mu}|z|^2/|\varepsilon|}\right)$$

with some positive constant $\tilde{\mu}$. Here some estimate analogous to (6.1) has been used. Differentiation yields $(v_l^{j+1} - v_l^j)'(z) = \mathcal{O}\left(|z|e^{-\tilde{\mu}|z|^2/|\varepsilon|}\right)$. This finally gives (6.3) for any positive $\alpha < \tilde{\mu}$.

The estimates (6.2) and (6.3) are exactly the important hypotheses of the Main Theorem 4.1 of the memoir [4]. We obtain composite asymptotic expansions (CASES) of Gevrey order 1 for the functions $w_l^j = (v_l^j)'$. Especially, we obtain CASES for $v_j' = (v_0^j)'$:

$$v_j'(z, \varepsilon) \sim \frac{1}{2} \sum_{n=0}^{\infty} \left(A_n(z) + B_n^j\left(\frac{z}{\eta}\right) \right) \eta^n \tag{6.4}$$

3. Starting here, we have to indicate the dependence of functions on ε again.

where the functions A_n are holomorphic on some disk centered at the origin, B_n^j are holomorphic on $i^{j-1}Q_+(2K, 2\delta)$ and have consistent asymptotic expansions of Gevrey order $\frac{1}{2}$

$$B_n^j(Z) \sim \frac{1}{2} \sum_{m \geq 1} D_{nm} Z^{-m} \text{ as } Z \rightarrow \infty.$$

We refer to the explanations below Theorem 2.4 for details.

Finally, we use the initial conditions for v_j . In the case $j = 1$ (the others are analogous), we have

$$v_1(z, \varepsilon) = K\varepsilon + \int_{\eta Y_+(K)}^z v_1'(\zeta, \varepsilon) d\zeta.$$

Now we separate the leading term of each B_n^1 , i.e. we write $B_n^1(Z) = D_{n1}Z^{-1} + C_n^1(Z)$, $C_n^1(Z) = \mathcal{O}(Z^{-2})$ and integrate (6.4) term by term (for details see [4]). We use $a_n(z) = \int_0^z A_n(\zeta) d\zeta$, $b_n^1(Z) = \int_\infty^Z C_n^1(u) du$ and we collect the terms independent of z in T_j . Thus we finally obtain the wanted CASE for v_1 .

The statement on b_0^j and b_0^l follows from the factor η in (6.3): Theorem 4.1 of [4] applies to the family $\frac{1}{\eta}(v_l^j)'$, $j = 1, \dots, 4$, $l = 1, \dots, L$. The leading term $a_0(z)$ can be determined using the Schröder equation (7.4). The fact that the right hand side of the outer expansion (2.14) is a formal solution of (7.4) implies that it contains only powers of $\varepsilon = \eta^2$.

7. Application.

We present in this section an informal study of equation (1.9), rewritten below for convenience:

$$\Delta_\varepsilon y = 1 + \frac{1}{y}. \tag{7.1}$$

It is well known that, for fixed $\varepsilon > 0$, the difference equation (7.1) has solutions holomorphic on sectors with vertex at infinity. The dependence on ε , however, is not clear. We start our study with the subsequent proposition. We use the notation of the somewhat similar study of the inner reduced equation of Section 3. In particular $\Omega_+(K, \delta)$ is defined in (2.7) and shown on Figure 2.1.

Proposition 7.1 . *Fix $\varepsilon_0 > 0$. For all $\delta > 0$ there exists $K > 0$ such that (7.1) has a unique solution y_+^∞ defined for $\varepsilon \in]0, \varepsilon_0]$, $x \in \Omega_+(K, \delta)$ holomorphic with respect to x satisfying*

$$y_+^\infty(x, \varepsilon) = x + \log x + o(1) \text{ as } x \rightarrow \infty \text{ in } \Omega_+(K, \delta). \tag{7.2}$$

Similarly, there is a unique solution y^∞ on $-\Omega_+(K, \delta)$ satisfying $y^\infty(x, \varepsilon) = x + \log x + o(1)$ as $x \rightarrow \infty$ in $-\Omega_+(K, \delta)$. On $-\Omega_+(K, \delta)$ we use the branch of the logarithm given by $\log x = \log(-x) + \pi i$; on $\Omega_+(K, \delta)$ we use the principal value.

The proof is similar to that of Proposition 2.1 and is omitted. If K is sufficiently large, then the solutions y_{\pm}^{∞} have inverse functions v_{\pm}^{∞} also called Fatou coordinates. These are holomorphic functions of their first variable in some domain containing infinite sectors $\pm\Omega_{+}(\tilde{K}, \tilde{\delta})$ with some $\tilde{K} > K, \tilde{\delta} > \delta$. They satisfy

$$v_{\pm}^{\infty}(z, \varepsilon) = z - \log z + o(1) \text{ as } z \rightarrow \infty \tag{7.3}$$

and the functional equation

$$v\left(z + \varepsilon\left(1 + \frac{1}{z}\right)\right) = v(z) + \varepsilon. \tag{7.4}$$

The formula $v_{-}^{\infty} \circ y_{+}^{\infty} - \text{id}$ defines two functions p_{\pm}^{∞} on the sector \mathcal{I}_{+} introduced above (2.10), respectively on $\mathcal{I}_{-} = -\mathcal{I}_{+}$. They are bounded and ε -periodic and hence there exist Fourier expansions

$$p_{\pm}^{\infty}(x, \varepsilon) = \sum_{n=0}^{\infty} c_{n\pm}^{\infty} e^{2\pi i n x / \varepsilon} \tag{7.5}$$

with functions $c_{n\pm}^{\infty} :]0, \varepsilon_0] \rightarrow \mathbb{C}$ which we call *Écalle-Voronin invariants of (7.1) at ∞* . The choice of the branches of the logarithms in Proposition 7.1 implies that $c_{0+}^{\infty} = 0$ and $c_{0-}^{\infty} = -2\pi i$.

We want to study the relation between these invariants of (7.1) at infinity and its *Écalle-Voronin invariants near 0* introduced above Corollary 2.5 which will be denoted by $c_{jn}^0(\varepsilon)$.

To this purpose, we first prove that v_{+}^{∞} can be continued up to the domain \tilde{Q}_1 of our local solution v_1^* given by Proposition 2.3 and by (2.16). The outer reduced equation of (7.1) is $y' = 1 + \frac{1}{y}$, whose solutions are implicitly given by

$$y - \log(1 + y) = x + C. \tag{7.6}$$

Then Corollary 6.4 shows that y_{+}^{∞} can be continued along the level lines $a_0(y) = y - \log(1 + y) = t + Ci, t \in [t_1, t_2]$, for any $t_1, t_2, C \in \mathbb{R}, t_1 < t_2, C \neq 0$. As a consequence, v_{+}^{∞} can be continued analytically onto any compact set included in the dark region displayed on Figure 7.1 top right, where a_0 is locally invertible. In particular v_{+}^{∞} can be continued on the set $\{z \in \tilde{Q}_1; |z| > r_1\}$ for an arbitrary $r_1 \in]0, r[$. We then apply Lemma 6.1 to y_1 and y_{+}^{∞} . This allows to continue v_{+}^{∞} on \tilde{Q}_1 in its whole. By Corollary 6.3, there exists $s = s(\varepsilon) = \mathcal{O}(\varepsilon)$ such that the function $v_{+}^{\infty} - v_1^* - s(\varepsilon)$ is exponentially small in any compact subset of \tilde{Q}_1 . We call this function s the *shift* in the sequel. We will now compare some asymptotic expansions of v_1^* and v_{+}^{∞} .

Therefore, we first indicate how to prove that v_{+}^{∞} does have an asymptotic expansion. For this, we consider all arguments of ε . Using (7.5), we prove that $(v_{+}^{\infty})'$ and $(v_1^*)'$ are exponentially close one to each other on \mathcal{I}_{+} and \mathcal{I}_{-} , and then we apply Ramis-Sibuya's theorem (classical, see for example [4], Lemma 4.4).

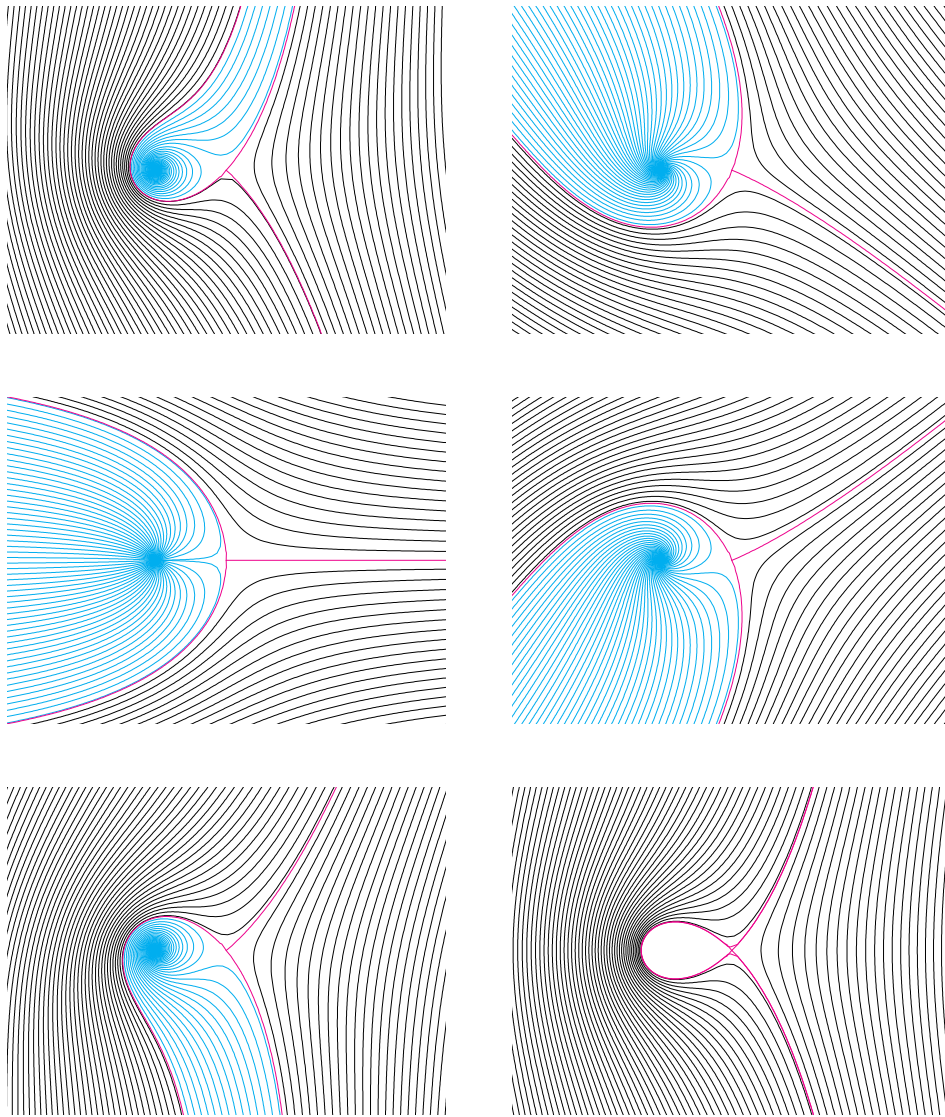

Figure 7.1. In dark, the level lines $y - \log(1 + y) = (t + C)e^{i\theta}$, $t \in \mathbb{R}$, in the regions D_θ , successively for $\theta = -\frac{\pi}{2} + 0.1, -\frac{\pi}{4}, 0, \frac{\pi}{4}, \frac{\pi}{2} - 0.2, \frac{\pi}{2}$.

In this manner, we obtain that $(v_+^\infty)'$ and $(v_-^\infty)'$ have a common asymptotic expansion $\hat{w}(z, \varepsilon) = \sum_{n \geq 0} w_n(z) \varepsilon^n$ which is of Gevrey order 1, uniformly for $z \in Q_+(2K, 2\delta)$.

resp. $z \in Q_-(2K, 2\delta) = iQ_+(2K, 2\delta)$. By integration, we finally obtain the desired expansion for v_+^∞ .

We can precisely describe \widehat{w} : Using the Schröder equation (7.4), expanding its left hand side by the Taylor formula, and cancelling the terms $v(z)$, we obtain for \widehat{w} the equation

$$\sum_{n \geq 0} \frac{\varepsilon^n}{(n+1)!} \left(1 + \frac{1}{z}\right)^n \widehat{w}^{(n)}(z, \varepsilon) = 1 - \frac{1}{1+z},$$

from which w_n can be determined recursively. Since, for any rational function f , $(1 + \frac{1}{z})^n f^{(n)}(z)$ has the same valuation in $1+z$ as f , we obtain that $(1+z)w_n(z)$ is a polynomial in $\frac{1}{z}$. More precisely, we obtain with some constants $w_{n\nu}$

$$w_n(z) = \frac{1}{1+z} \sum_{\nu=n}^{2n-1} w_{n\nu} z^{-\nu}. \tag{7.7}$$

Using a partial fraction expansion and integrating, we obtain for v_+^∞ an expansion of the form

$$v_+^\infty(z, \varepsilon) \sim_1 z - q(\varepsilon) \log(1+z) + (q(\varepsilon) - 1) \log z + \sum_{n \geq 1} v_n(z) \varepsilon^n + C(\varepsilon) \tag{7.8}$$

where $C(\varepsilon), q(\varepsilon)$ are formal series in ε , and v_n is a polynomial of degree at most $2n - 2$ in $\frac{1}{z}$ without constant term, i.e. $v_n(z) = \sum_{\nu=1}^{2n-2} v_{n\nu} z^{-\nu}$.

The estimate (7.3) yields $C = 0$. The Schröder equation permits also to determine q explicitly. Actually, the right hand side, denoted by \widehat{v} , of (7.8) can be rewritten in the form

$$\widehat{v}(z, \varepsilon) = -q(\varepsilon) \log(1+z) + \sum_{n \geq 0} h_n(z) \varepsilon^n,$$

where the functions h_n are holomorphic in a neighborhood of $z = -1$. Since \widehat{v} is a formal solution of (7.4), we obtain

$$-q(\varepsilon) \log\left(1 + \frac{\varepsilon}{z}\right) = \varepsilon + \sum_{n \geq 0} \left(h_n(z) - h_n\left(z + \varepsilon\left(1 + \frac{1}{z}\right)\right) \right) \varepsilon^n.$$

For the value $z = -1$, this gives

$$q(\varepsilon) = \frac{-\varepsilon}{\log(1-\varepsilon)}. \tag{7.9}$$

We will use later on $q(\varepsilon) = 1 - \frac{\varepsilon}{2} + \mathcal{O}(\varepsilon^2)$. We want to compare the former expansion (7.8) with the outer expansion of v_1^* . In our example, the outer expansion (2.14) rewritten for $v_1^* = v_1 - T_1$ becomes

$$v_1^*(z, \eta^2) \sim_{\frac{1}{2}} S(\eta) \log\left(\frac{z}{\sqrt{2}\eta}\right) + \sum_{n \geq 0} d_n(z) \eta^n \tag{7.10}$$

with $d_n(z) = a_n(z) + \sum_{m=1}^{n-2} B_{n-m,m} z^{-m}$, a_n holomorphic in a neighborhood of 0.

Since $a_n(0) = 0$ by Theorem 2.4, d_n has no constant term. Now a comparison of (7.8) and (7.10) gives (with $\varepsilon = \eta^2$)

$$S(\eta) = q(\varepsilon) - 1, \quad d_n = a_v + v_n, \quad \text{and} \quad a_n = \alpha_n \log(1 + z)$$

with some constant α_n . Concerning the shift s , we obtain

$$s(\varepsilon) = S(\eta) \log(\sqrt{2}\eta) + \mathcal{O}(e^{-c/\varepsilon}) = \frac{1}{2}(q(\varepsilon) - 1) \log(2\varepsilon) + \mathcal{O}(e^{-c/\varepsilon}).$$

In the same manner, we can continue v_-^∞ onto \tilde{Q}_2 and compare the expansions of v_-^∞ and of the local solution v_2^* . Regarding the Écalle-Voronin invariants c_{n+}^∞ , we finally obtain in a similar way as for (2.17) first $p_+^\infty(x, \varepsilon) = p_1(x - s(\varepsilon), \varepsilon)$ where $p_1 = v_2^* \circ (v_1^*)^{-1} - \mathbf{id}$ and thus

$$c_{n+}^\infty(\varepsilon) = c_{1n}^0(\varepsilon) \exp\left(-n\pi i \frac{q(\varepsilon)-1}{\varepsilon} \log(2\varepsilon)\right).$$

In this manner, we obtain an asymptotic expansion of Gevrey order 1 for c_{n+}^∞ :

$$c_{n+}^\infty(\varepsilon) \exp\left(n\pi i \frac{q(\varepsilon)-1}{\varepsilon} \log(2\varepsilon)\right) \sim \frac{1}{2} \sum_{n \geq 2} a_{1nk} \varepsilon^{k/2}. \tag{7.11}$$

A careful analysis shows that the former discussion can be extended to all arguments of ε , except $\arg \varepsilon = \frac{\pi}{2}$. In other words, for any $\delta > 0$, the expansion (7.11) is valid uniformly for $\varepsilon \in S\left(-\frac{3\pi}{2} + \delta, \frac{\pi}{2} - \delta, \varepsilon_0\right)$.

As shows the picture on bottom right of Figure 7.1, which corresponds to $\arg \varepsilon = \frac{\pi}{2}$, something happens for this value: There is a loop surrounding -1 that is parametrized by $y - \log(1 + y) = -it$, $0 < t < 2\pi$ real, where $y \sim (2t)^{1/2} e^{3\pi/4}$ for small t . This makes it impossible to continue v_+^∞ and v_-^∞ analytically to a *common* set of points at a distance $\mathcal{O}(\eta)$ from the origin on the ‘left hand’ side of the origin (on the right hand side, there is no problem – this corresponds to $\arg \varepsilon = -\frac{\pi}{2}$). Therefore we need an intermediate solution v_α of Schröder’s equation (7.4) defined in a neighborhood of the above loop.

In order to construct such a solution, recall that the solutions of the outer reduced equation of (7.1) are given implicitly by (7.6). We are interested in the solution y_0 that parametrizes the above loop for $x \in]-2\pi i, 0[$. It satisfies $y_0(x) - \log(1 + y_0(x)) = x$ and $y_0(x) \sim -\sqrt{2x}$ for small x , $\arg x$ close to $-\frac{\pi}{2}$. It can be continued analytically to some domain containing the open segment $]-2\pi i, 0[$, for example some open rhombus G with vertices $0, -\beta - i\pi, -2\pi i, \beta - i\pi$. By Theorem 7 of [3], for every compact subset K of G there exists a holomorphic solution y_α of (7.1) defined in some neighborhood of K satisfying $y_\alpha(x) = y_0(x) + \mathcal{O}(\varepsilon)$. We choose K as a rhombus with vertices $-\delta i, -\tilde{\beta} - \pi i, (\delta - 2\pi)i, \tilde{\beta} - i\pi$, $\delta > 0, 0 < \tilde{\beta} < \beta$.

For every small $\delta > 0$, there is a (also small) $\tilde{\beta} > 0$ such that y_0 is injective on K . As y_α is a holomorphic function close to y_0 , this is also true for y_α if ε is sufficiently small.

Thus y_α has an inverse function v_α that must be a solution of (7.4) and is close to a_0 given by $a_0(z) = z - \log(1 + z)$ on $y_\alpha(K) =: M$. Observe that M contains no reals close to 0 because of the injectivity. For convenience, let $M_\pm = \{z \in M; \pm \text{Im } z > 0\}$. Observe that here $\log(1 + z)$ is close to 0 if $z \in M_+$ is small, whereas it is close to $2\pi i$ if $z \in M_-$ is small.

Near $z = 0$, four solutions of (7.4) can be constructed as indicated in Section 6, i.e. analogously to Proposition 2.3. Let $v_j : Q_j \rightarrow \mathbb{C}$, $j = 1, \dots, 4$, denote these solutions with $Q_j = e^{(2j-1)\pi i/4}Q$, where Q is the image of $\Omega(M, r, \gamma)$ (with certain $M, r, \gamma > 0$) by $x \mapsto x^{1/2}$ introduced above Theorem 2.2. The domain Q is shown on Figure 2.2 (it has the name Q_1 there). Since $\arg \varepsilon = \frac{\pi}{2}$, the domains Q_1, \dots, Q_4 are now rotated by an angle of $\frac{\pi}{4}$ compared to the case $\arg \varepsilon = 0$ of Proposition 2.3.

Analogously to the beginning of this section, $p_+^\infty = v_-^\infty \circ y_+^\infty - \text{id}$ can be defined in some sector $\mathcal{I}_+ = \{x \in \mathbb{C}; |\arg(-x - L)| < \frac{\pi}{2} - \delta\}$, where $L, \delta > 0$. It can be shown by analytic continuation that $L > 0$ can be chosen small. Then p_+^∞ can be analytically continued by periodicity from \mathcal{I}_+ to the half plane $H_L = \{x \in \mathbb{C}; \text{Re } x < -L\}$ with small positive L . If L is small enough, then H_L has a nonempty intersection with the above rhombus K . On $K \cap \mathcal{I}_+$, we can write $v_-^\infty \circ y_+^\infty = (v_-^\infty \circ y_\alpha) \circ (v_\alpha \circ y_+^\infty) = (\text{id} + p_{\alpha-}) \circ (\text{id} + p_{\alpha+})$ with some ε -periodic functions $p_{\alpha\pm}$.

Now these functions $p_{\alpha\pm}$ can be studied as before by continuing v_α, v_\pm^∞ analytically. If δ is small enough, then M_+ has a nonempty intersection with Q_2 , whereas M_- has nonempty intersection with Q_3 . We can continue v_α analytically from M_+ to all of Q_2 , if r is small enough. In order to still have a well defined function, we restrict this continuation to the intersection $Q_2^+ = \{z \in Q_2; \text{Im } z > 0\}$ of Q_2 with the upper half plane. Similarly, we analytically continue v_α from M_- to all of Q_3^- . As before v_+^∞ can be continued analytically to Q_1 and v_-^∞ can be continued analytically to Q_4 .

There exist shifts $s_{\alpha\pm}(\varepsilon)$ such that $v_\alpha(z) - v_2^*(z) - s_{\alpha+}(\varepsilon)$, resp. $v_\alpha(z) - v_3^*(z) - s_{\alpha-}(\varepsilon)$ are exponentially small on Q_2^+ , resp. Q_3^- . We have shown above that $v_+^\infty(z) - v_1^*(z) - s(\varepsilon)$ is exponentially small for $s(\varepsilon) = \frac{1}{2}(q(\varepsilon) - 1) \log(2\varepsilon) = -\frac{\varepsilon}{4} \log(2\varepsilon)(1 + o(1))$. Analogously $v_-^\infty(z) - v_4^*(z) - \tilde{s}(\varepsilon)$ turns out to be exponentially small for $\tilde{s}(\varepsilon) = \frac{1}{2}(q(\varepsilon) - 1) \log(2\varepsilon) - 2\pi i q(\varepsilon)$. This yields $p_{\alpha-}(x, \varepsilon) = p_3(x - s_{\alpha-}(\varepsilon), \varepsilon) + \tilde{s}(\varepsilon) - s_{\alpha-}(\varepsilon) + \mathcal{O}(e^{-c/|\varepsilon|})$ and $p_{\alpha+}(x, \varepsilon) = p_1(x - s(\varepsilon), \varepsilon) - s(\varepsilon) + s_{\alpha+}(\varepsilon) + \mathcal{O}(e^{-c/|\varepsilon|})$ where p_1, p_3 are the Écalte-Voronin invariants of (7.1) and c is some positive constant. Because of $\text{id} + p_+^\infty = (\text{id} + p_{\alpha-}) \circ (\text{id} + p_{\alpha+})$, we have altogether⁴

$$p_+^\infty(x) = p_1(x - s) + p_3(x - s + p_1(x - s) + s_{\alpha+} - s_{\alpha-}) + s_{\alpha+} - s_{\alpha-} + \tilde{s} - s.$$

As we know that $p_j(x)$ are exponentially close to the sums of the positive powers of $e^{2\pi i x/\varepsilon}$, i.e. to $\sum_{n \geq 0} c_{jn} e^{2\pi i n x/\varepsilon}$, $j = 1, 3$, we can express the Fourier coefficients of p_+^∞ by those of p_1, p_3 except for exponentially small terms. Especially we find

$$c_{1+}^\infty(\varepsilon) = e^{-2\pi i s(\varepsilon)/\varepsilon} (c_{1,1}(\varepsilon) + c_{3,1}(\varepsilon) e^{2\pi i (c_{1,0} + s_{\alpha+} - s_{\alpha-})(\varepsilon)/\varepsilon}) + \mathcal{O}(e^{-c/|\varepsilon|}).$$

4. We omit the dependence upon ε here.

The facts that v_1^* and v_2^* have the same outer expansion (2.14) and that they are Gevrey, imply that $c_{1,0}(\varepsilon)$ is exponentially small and it remains to determine $s_{\alpha+} - s_{\alpha-}$. This is done again using a Gevrey expansion of v_α and the outer expansions of v_2^*, v_3^* . Because of the different determinations of $\log(1+z)$ on M_\pm , we find that $(s_{\alpha+} - s_{\alpha-})(\varepsilon) = 2\pi i q(\varepsilon)$ and thus that altogether

$$c_{1+}^\infty(\varepsilon) = e^{-\pi i (q(\varepsilon)-1) \log(2\varepsilon)/\varepsilon} \left(c_{1,1}(\varepsilon) + c_{3,1}(\varepsilon) e^{-4\pi^2 q(\varepsilon)/\varepsilon} \right) + \mathcal{O}(e^{-c/|\varepsilon|}), \quad (7.12)$$

where $c_{j,1}$, $j = 1, 3$ are the Écalle-Voronin invariants of (7.1) at the origin which, according to Proposition 2.5, have Gevrey- $\frac{1}{2}$ asymptotic expansions

$$c_{j,1}(\varepsilon) \sim \frac{1}{2} \sum_{n \geq 2} a_{j1n} \eta^n, \quad j = 1, 3,$$

where $a_{112} = C_1^+$, $a_{312} = e^{-\pi^2} C_1^+$ and C_1^+ is the first Écalle-Voronin invariant for the inner reduced equation (2.6), cf (2.10). It can be shown numerically that it does not vanish.

Since $(q(\varepsilon) - 1)/\varepsilon$ is bounded, we see that c_{1+}^∞ vanishes exponentially close to values of ε where the sum of the two terms in the parenthesis vanishes. Our asymptotic expression implies that there is a sequence of such $(\varepsilon_k)_{k \in \mathbb{N}}$ and that (except for some integer shift) they satisfy

$$\varepsilon_k^{-1} \sim_1 \frac{1}{2\pi i} \left(k + \frac{1}{2} \right) + \frac{1}{4} + \sum_{l \geq 1} \beta_l k^{-l/2}$$

with certain coefficients β_l .

8. References

- [1] X. BUFF, J. ÉCALLE, A. EPSTEIN, “Limits of degenerate parabolic quadratic rational maps”, *Geom. Funct. Anal.* num. 23, 2013, 42–95.
- [2] J. ÉCALLE, “Théorie itérative: introduction à la théorie des invariants holomorphes”, *J. Math. Pures Appl.* num. 54, 1975, 183–258.
- [3] A. FRUCHARD, R. SCHÄFKE, “Analytic solutions of difference equations with small step size”, *J. Difference Eq. Appl.* num. 7, 2001, 651–684.
- [4] A. FRUCHARD, R. SCHÄFKE, “Composite Asymptotic Expansions”, *Lect. Notes Math.* num. 2066, Springer, 2013.
- [5] J. MARTINET, J.-P. RAMIS, “Problèmes de modules pour des équations différentielles non linéaires du premier ordre”, *Inst. Hautes Études Sci. Publ. Math.* num. 55, 1982, 63–164.
- [6] W. RUDIN, *Real and Complex Analysis*, Third Edition, Mc Graw-Hill, 1987.
- [7] S. M. VORONIN, “Analytic classification of germs of conformal mappings $(\mathbb{C}, 0) \rightarrow (\mathbb{C}, 0)$ ”, *Funktsional. Anal. i Prilozhen* num. 15, 1981, 1–17 (Russian; English translation: *Functional Anal. Appl.* num. 15, 1981, 1–13).